

Northumbria Research Link

Citation: Haigh, P.A., Chvojka, P., Minotto, A., Burton, Andrew, Murto, P., Wang, E., Ghassemlooy, Zabih, Zvanovec, S., Cacialli, F. and Darwazeh, I. (2019) Strategies for organic VLC: effects of clipping on the performance of multi-band CAP modulation with polymer-based light-emitting diodes. In: 45th European Conference on Optical Communication (ECOC 2019). IET Conference Publications (CP765). Institution of Engineering and Technology. ISBN 9781839531859

Published by: Institution of Engineering and Technology

URL: <https://doi.org/10.1049/cp.2019.1035> <<https://doi.org/10.1049/cp.2019.1035>>

This version was downloaded from Northumbria Research Link: <http://nrl.northumbria.ac.uk/id/eprint/46367/>

Northumbria University has developed Northumbria Research Link (NRL) to enable users to access the University's research output. Copyright © and moral rights for items on NRL are retained by the individual author(s) and/or other copyright owners. Single copies of full items can be reproduced, displayed or performed, and given to third parties in any format or medium for personal research or study, educational, or not-for-profit purposes without prior permission or charge, provided the authors, title and full bibliographic details are given, as well as a hyperlink and/or URL to the original metadata page. The content must not be changed in any way. Full items must not be sold commercially in any format or medium without formal permission of the copyright holder. The full policy is available online: <http://nrl.northumbria.ac.uk/policies.html>

This document may differ from the final, published version of the research and has been made available online in accordance with publisher policies. To read and/or cite from the published version of the research, please visit the publisher's website (a subscription may be required.)

Strategies for Organic VLC: Effects of Clipping on the Performance of Multi-Band CAP Modulation with Polymer-based Light-Emitting Diodes

P. A. Haigh^{1,2*}, P. Chvojka³, A. Minotto⁴, A. Burton⁵, P. Murto⁶, E. Wang⁶, Z. Ghassemlooy⁵, S. Zvanovec³, F. Cacialli⁴, I. Darwazeh²

¹Intelligent Sensing and Communications, School of Engineering, Newcastle University, NE1 7RU, UK

²Information and Communication Systems Engineering Group, University College London, WC1E 6BT, UK

³Department of Electromagnetic Field, Czech Technical University in Prague, Technicka 2, 16627, CZ

⁴Department of Physics and Astronomy, University College London, WC1E 6BT, UK

⁵Optical Communications Research Group, Faculty of Eng. And Env., Northumbria University, NE1 8ST, UK

⁶Department of Chemistry and Chemical Engineering Chemistry, Chalmers University of Technology, Sweden

*E-mail: paul.haigh@newcastle.ac.uk

Keywords: Digital Signal Processing, Modulation, Optical Communications, Visible Light Communications

Abstract

We investigate, for the first time, the effect of signal clipping on multi-band carrier-less amplitude and phase (*m*-CAP) modulation in visible light communications based on PLEDs. We experimentally demonstrate a *Q*-factor improvement up to ~ 2.25 dB can be obtained with a clipping level of 50%.

1 Introduction

Multi-band carrier-less amplitude and phase (*m*-CAP) modulation has emerged as one of the key modulation formats in high-speed visible light communication (VLC) systems [1,2]. This is because it offers advantages over other advanced multi-carrier modulation schemes such as orthogonal frequency division multiplexing (OFDM) due to the lower peak-to-average power ratio (PAPR) [3]. However, in VLC the system performance is limited by the linear region of the electro-optic response of light emitting diodes (LEDs) [4], which imposes limits on PAPR in multicarrier modulation, thus making the power efficiency an important factor. In addition, *m*-CAP also retains the advantages of OFDM such as bit- and power-loading [5] to maximise the data throughput. However, there is a trade-off between throughput and PAPR given that throughput increases with number of sub-bands *m*, as does probability of carrier phase alignment which leads to high peak power.

Concurrently, polymer LEDs (PLEDs) are becoming popular in VLC systems for point-to-point mobile links offering relatively high data rates up to >50 Mb/s [6]. PLEDs have numerous advantages over conventional LEDs such as mechanical flexibility and ultra-low-cost solution based processing, which makes them an ideal candidate for a number of applications in indoor environments. However, signals with a large signal are undesirable for PLED-based VLC systems (and inorganic VLC systems in general) due to their limited luminance and their dynamic range. Therefore, careful signal design is required to maximise the available throughput.

Clipping is a technique that has widely been adopted in OFDM as a method to reduce the PAPR [7] and the demand for linearity in LEDs. In [7] an iterative clipping technique was used to reduce PAPR by >4 dB. In [3], it was shown that based on the technique proposed in [7] OFDM is approximately equivalent to the single-band CAP in terms of PAPR. However, in general, further reduction in PAPR is advantageous

to enable the use of light sources with limited linear power-current characteristics, whilst continuing to take advantage of *m*-CAP modulation.

To date, there have been no reports on the use of clipping in CAP and *m*-CAP systems in order to acquire a PAPR gain. In this work, we introduce for the first time, clipping at the output of the modulator with no receiver modifications to demonstrate the impact of removing peak levels in *m*-CAP-based VLC. We have carried out experimental measurements for several orders of sub-bands (i.e., $m = \{1, 2, 4, 6, 8, 10\}$) and for a range of clipping levels (CLs) of 10% to 90%, and show that the measured received *Q*-factor reaches a peak at a CL of 50%, i.e., an improvement of ~ 2.25 dB.

2 Experimental Test Setup

The simplified block diagram of the proposed system under test is illustrated in Fig. 1. An independent pseudo-random binary sequence (PRBS) D_i of length $2^{15} - 1$ is generated for the *i*th sub-band and mapped onto the 4-level quadrature amplitude modulation (4-QAM). The signals are then up-sampled via zero padding at a rate of the number of samples-per-symbol N_{ss} , see [8], prior to pulse shaping using the standard square-root raised cosine (SRRC) basis function with a roll-off factor $\beta = 0.1$ to maintain high bandwidth efficiency [1][2]. The SRRC impulse response is multiplied by a cosine ($p(t)$) and sine ($\bar{p}(t)$) to generate Hilbert pair, which separates the signals in phase by 90° . Following pulse shaping, signals are summed before being clipped following [7]:

$$\bar{s}_k = \begin{cases} c_l & \text{if } s_k < c_l \\ s_k & \text{if } c_l \leq s_k \leq c_u \\ c_u & \text{if } s_k > c_u \end{cases} \quad (1)$$

where s_k and \bar{s}_k are the *k*th samples of the transmit signals before and after clipping, respectively. The lower and upper clipping limits are given by c_l and c_u , respectively. In this work, we set $c_l = c_u$ as a percentage of the normalised signal maximum. Next, the clipped signal vector $\bar{\mathbf{s}}$ is the output from the

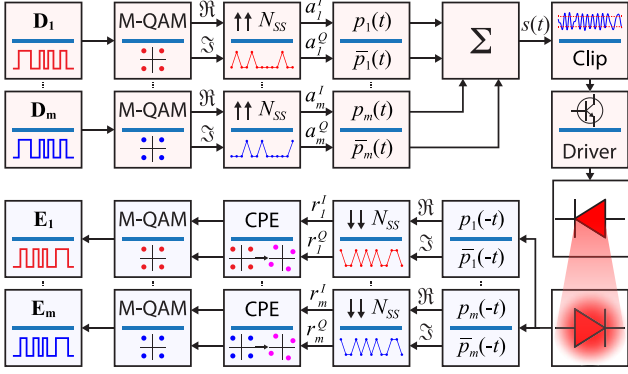

Fig. 1. Simplified block diagram of the experimental test setup

Tektronix AWG70002A arbitrary waveform generator prior to four times amplification (not shown in Fig. 1) and intensity modulation of the red PLED via a custom driver.

The PLED under test was fabricated via solution processing in a nitrogen-filled glove-box, by spin-casting a 10 mg/mL toluene solution of the red-emitting polymer (PIDT-2TPD, number average molecular weight = 63.7 kDa, polydispersity index = 2.3 whose synthesis has been reported previously [9]) onto a glass substrate prepatterned with transparent indium-tin oxide (ITO) anodes (OSSILA Ltd), to obtain a ~ 100 nm thick emissive layer. Prior to this, the ITO substrate was treated in an oxygen plasma chamber and covered with a 40 nm layer of hole-injecting poly(3,4-ethylenedioxythiophene)-poly(styrenesulfonate) (PEDOT:PSS), deposited via spin-coating from a water dispersion (Heraeus CleviosTM AI 4083). Following the deposition of the active layer, Ca/Al (30/200 nm) cathodes were thermally evaporated to enable ohmic electron injection. Finally, the PLED was encapsulated in the glove-box following the same protocol reported in [6].

The PLED offers a modulation bandwidth of ~ 500 kHz, which is an order of magnitude higher than most commercially available organic LEDs, and its optoelectronic characteristics can be found in [9]. The L - I - V characteristics are illustrated in Fig. 2 to highlight the limited linear electro-optic range available (red curve) alongside its linear fit (blue dashed curve). The signal bandwidth is set equal to the PLED bandwidth to avoid undesired effects, i.e. out-of-band attenuation or interference.

The transmission distance is set to 5 cm because of the small area of a single PLED pixel (i.e., 4.5 mm^2). Nevertheless, a matrix of pixels could be used to improve the luminance and thus increase the transmission distance. At the receiver, a Thorlabs PDA36A2 is used that is composed of a silicon photodiode and packaged transimpedance amplifier (12 MHz bandwidth and 0 dB gain). Next, the receiver output is boosted using a 20 dB gain electrical amplifier. A minimum of 10^6 samples are used for each test at a sampling frequency of 62.5 MS/s, which are then imported into MATLAB for offline resampling to the transmit rate, demodulation and processing.

The demodulation process is performed by passing the received signals through time-reversed matched filters $p(-t)$ and $\bar{p}(-t)$ before mid-point down-sampling at a rate of N_{ss} . Any common phase error (CPE) is removed using standard methods prior to constellation de-mapping and bits estimation

E_i . The Q -factor of the acquired signals is measured for each signal transmitted, varying m and the CL.

3 Results

The average PAPR as a function of the clipping and with no clipping for a range of m -CAP signals is shown in Fig. 3.

For the unclipped signals, the PAPR increases from ~ 8.5 dB to >13 dB for m of 1 and 10, respectively, which is a large increase considering the highly limited dynamic range of the PLEDs (I - L in Fig. 2). With increased clipping, the PAPR decreases linearly to <2 dB at a CL of 90% for all m .

In Fig. 4 we illustrate the Q -factor as a function of clipping for the i^{th} sub-band s_i of the 10-CAP signal. We observe that, with no clipping, the Q -factor steadily decreases from 12 dB to 8 dB for $i = 2$ to 10, respectively due to the penalty induced by the closure of the horizontal eye, which is introduced by increasing the frequency of each sub-band [8]. However, the first sub-band (i.e., $i = 1$) suffers a penalty due to a coupling capacitor used in the PLED driver circuit, which introduces attenuation at the low-frequency region, hence causing a separate Q -factor penalty. The measured Q -factor of each sub-band improves by increasing the clipping level, reaching maximum values at a CL of ~ 50 -60% (i.e., ~ 3 dB improvement). Considering the sporadic signal peaks experienced in m -CAP, there

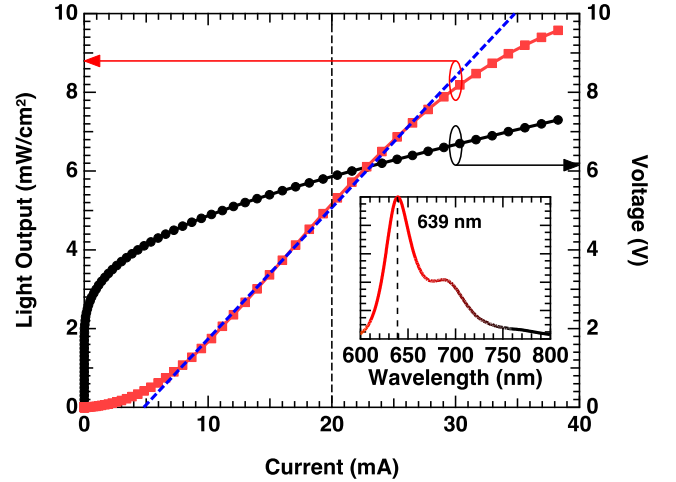

Fig. 2. The measured PLED L - I - V curve and electroluminescence spectrum (inset measured at 20 mA)

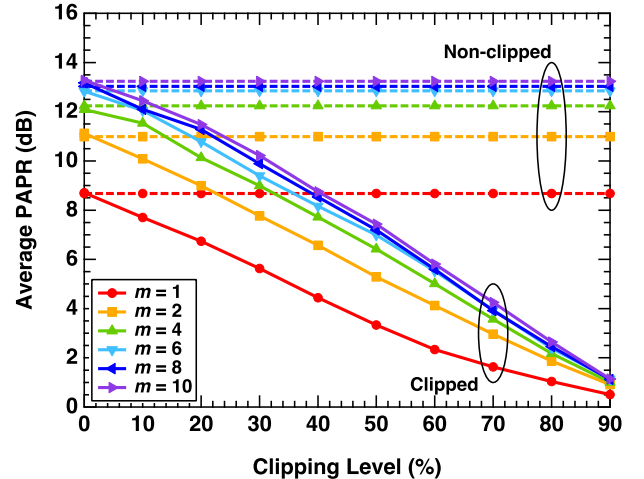

Fig. 3. Average PAPR of m -CAP before and after clipping

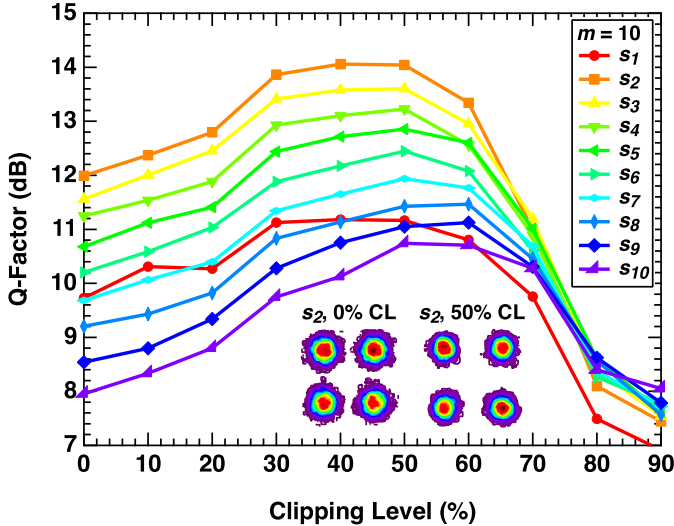

Fig. 4. Measured Q -factor for every sub-band s when $m = 10$ is an advantage gained by better utilising the dynamic range of PLED electro-optic response, which leads to improved signal-to-noise ratio (SNR) performance. Therefore, increasing the power efficiency of the signal leads to improved Q -factor by the way of eliminating large signal peaks. Beyond a CL of $>60\%$ the Q -factor values drops reaching values below 8 dB at 90% clipping, which is attributed to the clipping noise. Constellation diagrams for sub-band s_2 are shown inset for clipping values of 0% and 50%. Fig. 5 depicts the normalised magnitude response for 10-CAP with and without clipping. Note the spectral leakage, which results in high levels of inter-band interference, rapidly degrades the Q -factor.

Note, for $m < 10$, the improvement in Q -factor becomes less significant. This is highlighted in Fig. 6, where the maximum relative Q -factor (normalised to a CL of 0%) is taken across all sub-bands for each order of m tested. Clearly, for $m = \{8, 10\}$ we observe the best performance over the entire clipping range with an average gain of ~ 2 dB at a CL of 50% (see the inset in Fig. 6). For $m = \{6, 4\}$ and the gain is dropped to average of 1.4 dB (40% CL) and to 0.5 dB (30% CL) for $m = 2$. No reasonable gain is measured for $m = 1$ (~ 0.25 dB, 10% CL). The reason the peak gain occurs at lower CLs for lower values of m is due to the fact there are fewer carriers to potentially align and hence, there is a much lower number of peak amplitudes. Thus, leading to lower PAPR (see Fig. 3), and improved power efficiency as well as more effective use of the PLED's dynamic range with the signal experiencing a reduced level of clipping. Of course, as expected, for $m = 1$ we observe no practical gain in the Q -factor for the entire range of CL.

4 Conclusion

This paper has experimentally demonstrated the effects of clipping on m -CAP signals for use in PLED-based VLC systems. We found that a CL of 50% resulted in the highest average improvement in Q -factor (~ 2 dB) for high orders of sub-bands ($m = 8, 10$). This was because high peaks are more likely with higher orders of sub-bands due to alignment of carrier frequencies. These peaks were removed from the signals, resulting in higher SNR and improved Q -factor. For lower number of

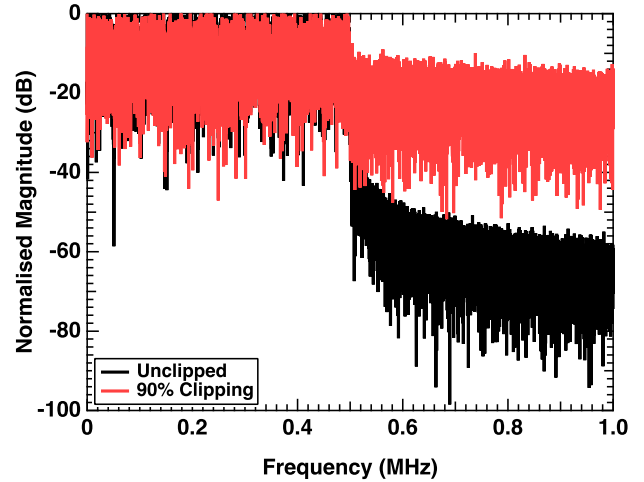

Fig. 5 Comparison of clipped and unclipped spectra; out-of-band noise significantly enhanced through clipping

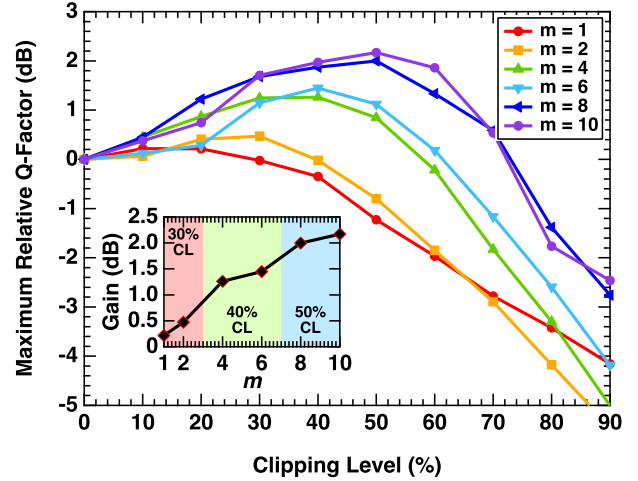

Fig. 6. Relative Q -factor deviation

sub-bands, the average Q -factor gain was reduced to ~ 1.4 dB ($m = 4, 6$) and 0.5 dB ($m = 2$). For $m = 8$ and 10 the gains are attributed to the ability to exploiting the entire power-current dynamic range of the PLED to transmit signals with higher average power levels, hence increasing the SNR.

5 Acknowledgements

UK EPSRC grant EP/P006280/1: MARVEL, Horizon 2020 FP MSC ITN grant 764461 (VISION), FC holds a Royal Society Wolfson Foundation Research Merit Award. EW acknowledges the Swedish Research Council, Swedish Research Council Formas and the Wallenberg Foundation.

6 References

- [1] Y. Wang, *et al.*, Opt. Express, **23**(10), 2015
- [2] S. Liang, *et al.*, IEEE Photon. J., **10**(1), 2018
- [3] M. Khaligi, *et al.*, IEEE Access, **5**, 2017
- [4] H. Elgala, *et al.*, IEEE Photon. Technol. Lett., **22**(11), 2010
- [5] P. A. Haigh, *et al.*, IEEE JSAC, **33**(9), pp.1819-1828, 2015
- [6] P. a. Haigh, *et al.*, IEEE JSAC, **33**(9), pp.1771-1779, 2015
- [7] Z. Yu, *et al.*, IEEE Mil. Commun. Conf., 2014
- [8] M. I. Olmedo, *et al.*, J. Light. Technol., **32**(4), 2014
- [9] A. Minotto, *et al.*, Adv. Mater., **30**(34), 2019