

NASA TECHNICAL NOTE



NASA TN D-8248 *e.1*

NASA TN D-8248

LOAN COPY: F  
AFWL TECHNICAL  
KIRTLAND AF



# STREAKLINE FLOW VISUALIZATION OF DISCRETE-HOLE FILM COOLING WITH NORMAL, SLANTED, AND COMPOUND ANGLE INJECTION

*Raymond S. Colladay and Louis M. Russell*

*Lewis Research Center*

*Cleveland, Ohio 44135*

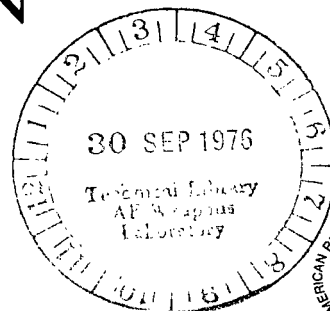



0133995

1. Report No. <b>NASA TN D-8248</b>	2. Government Accession No.	3. Recipient's Catalog No.	
4. Title and Subtitle <b>STREAKLINE FLOW VISUALIZATION OF DISCRETE-HOLE FILM COOLING WITH NORMAL, SLANTED, AND COMPOUND ANGLE INJECTION</b>		5. Report Date <b>September 1976</b>	6. Performing Organization Code
7. Author(s) <b>Raymond S. Colladay and Louis M. Russell</b>		8. Performing Organization Report No. <b>E-8418</b>	
9. Performing Organization Name and Address <b>Lewis Research Center          National Aeronautics and Space Administration          Cleveland, Ohio 44135</b>		10. Work Unit No. <b>505-04</b>	
12. Sponsoring Agency Name and Address <b>National Aeronautics and Space Administration          Washington, D.C. 20546</b>		11. Contract or Grant No.	
15. Supplementary Notes		13. Type of Report and Period Covered <b>Technical Note</b>	
16. Abstract  <p>Film injection from discrete holes in a three-row, staggered array with five-diameter spacing was studied for three hole angles: (1) normal, (2) slanted 30<sup>0</sup> to the surface in the direction of the main stream, and (3) slanted 30<sup>0</sup> to the surface and 45<sup>0</sup> laterally to the main stream. The ratio of the boundary layer thickness-to-hole diameter and Reynolds number were typical of gas-turbine film-cooling applications. Detailed streaklines showing the turbulent motion of the injected air were obtained by photographing very small neutrally buoyant, helium-filled "soap" bubbles which follow the flow field.</p>		14. Sponsoring Agency Code	
17. Key Words (Suggested by Author(s)) <b>Flow visualization          Film cooling          Heat transfer          Gas turbine</b>		18. Distribution Statement <b>Unclassified - unlimited          STAR Category 34 (rev.)</b>	
19. Security Classif. (of this report) <b>Unclassified</b>	20. Security Classif. (of this page) <b>Unclassified</b>	21. No. of Pages <b>21</b>	22. Price* <b>\$3.50</b>

# STREAKLINE FLOW VISUALIZATION OF DISCRETE-HOLE FILM COOLING WITH NORMAL, SLANTED, AND COMPOUND ANGLE INJECTION

by Raymond S. Colladay and Louis M. Russell

Lewis Research Center

## SUMMARY

Film injection from discrete holes in a three-row staggered array with five-diameter spacing was studied for three different hole angles: (1) normal, (2) slanted  $30^{\circ}$  to the surface in the direction of the main stream, and (3) slanted  $30^{\circ}$  to the surface and  $45^{\circ}$  laterally to the main stream. The ratio of the boundary-layer thickness-to-hole-diameter and Reynolds number were typical of gas-turbine film-cooling applications. Detailed streaklines showing the turbulent motion of the injection air were obtained by photographing very small, neutrally buoyant, helium-filled "soap" bubbles, which follow the flow field. The streakline pattern associated with the slanted in-line hole configuration shows the film separating from the surface and penetrating into the free-stream at film-to-main-stream mass flux ratios greater than about 0.5. With compound angle injection the film streaklines wrap into a single, tightly wound vortex filament. The resulting high vorticity in the film layer keeps the injectant attached to the surface at much higher blowing rates than in the slanted in-line case. Normal injection should be avoided whenever possible because it leads to excessive turbulent mixing between the film jet and the main stream and the film separates from the surface at relatively low blowing rates.

## INTRODUCTION

Increases the turbine-inlet temperature and pressure have reached the point where heat flux levels are too high to adequately cool hot-section gas-turbine components by convection alone. Some film cooling is generally required to protect the metal parts from the hot gas stream. The most practical method currently used for film cooling aircraft turbines is to inject the cooling air from discrete holes in the surface of the blades. It is important that the air be injected in the most efficient manner to provide the desired heat-transfer protection with a minimum disruption of the main stream. Poorly designed

film-injection schemes can lead to main-stream momentum losses which severely reduce turbine aerodynamic efficiency and, in some instances, even increase heat transfer to the surface.

There has been considerable emphasis recently in experimental heat-transfer studies related to discrete-hole film cooling. Erikson (ref. 1) and his predecessors at the University of Minnesota investigated adiabatic wall film effectiveness and augmented heat-transfer coefficients due to blowing for one hole and a single row of holes at various injection angles and center-to-center spacings. Reference 1, the last in a series of reports on this study, includes a bibliography of the earlier reports in the series. Liess (ref. 2) has made a similar study for a single row of injection holes with a free-stream static-pressure distribution typical of turbine-blade applications. Crawford, Choe, Kays, and Moffat have investigated the heat-transfer characteristics of full coverage film cooling from a staggered array of discrete holes spaced 5 and 10 diameters apart. Normal injection results from this study are presented in references 3 and 4, and reference 5 is a summary data report containing all of the test results for both normal and  $30^\circ$  injection. Metzger, Takeuchi, and Kuenstler (ref. 6) examined surface averaged heat-transfer rates associated with a full coverage pattern of discrete holes oriented normal to the surface. Mayle and Camarata (ref. 7) investigated the adiabatic wall film effectiveness associated with full coverage film cooling from compound angle injection at various hole spacings. Analytical and experimental work in this same area has been the subject of several reports from Imperial College (refs. 8 and 9).

Although all of these investigations have contributed to the quantitative data needed to develop reliable analytical models of film cooling, they have also suggested the need for a better understanding of the complex fluid dynamics encountered when film air is injected through discrete holes into a turbulent boundary layer. One particularly effective method of acquiring this understanding is through the use of flow visualization studies. Reference 10 presents results from a streakline flow visualization study of film cooling from an array of closely spaced discrete holes. Ambient air was seeded with small neutrally buoyant helium-filled bubbles and injected into a turbulent boundary layer through holes angled  $30^\circ$  to the surface and directed downstream. The paths traced by the bubbles map streakline patterns of the injectant mixing with the main stream. The bubble streaklines are clearly identifiable as continuous thread-like streaks that can be traced through the film-injection region.

The present report compares the  $30^\circ$  injection results of reference 10 with those for two other hole configurations typically encountered in turbine applications, namely, normal injection and compound angle injection, where the holes are slanted  $30^\circ$  to the surface and  $45^\circ$  laterally to the main stream. In all three configurations the holes were arranged in the same three-row staggered array at a five-diameter spacing with a flat test surface, a zero pressure gradient main stream flow, a momentum thickness Reynolds

number just upstream of the injection holes of 2200, and a boundary layer thickness-to-hole diameter ratio of 1.75.

Motion picture supplement C-284, which illustrates the flow visualization technique and results for all three injection angles, has been prepared and is available on loan. A request card and a description of this film is included at the back of this report.

## SYMBOLS

D	film injector hole diameter, m
H	shape factor, $\delta^*/\theta$
m	film-to-main-stream velocity ratio or blowing rate
$Re_\theta$	momentum thickness Reynolds number, $u_\infty\theta/\nu$
u	velocity, m/sec
$u_f$	film injection velocity, m/sec
$u_\infty$	free-stream velocity, m/sec
$u^+$	dimensionless velocity, $u/\sqrt{\tau_w/\rho}$
y	coordinate normal to the surface, m
$y^+$	dimensionless distance, $y\sqrt{\tau_w/\rho}/\nu$
$\delta$	boundary layer thickness, m
$\delta^*$	displacement thickness, m
$\theta$	boundary-layer momentum thickness, m
$\nu$	kinematic viscosity, $m^2/\text{sec}$
$\rho$	density, $kg/m^3$
$\tau_w$	shear stress at the wall, $N/m^2$

## EXPERIMENTAL APPARATUS AND PROCEDURE

### Bubble Generator

The bubble generator system, described in detail in its manufacturer's report (ref. 11), consists of a head, which is the device that actually forms the bubbles, and a console containing micrometering valves which control the flow of the helium, the bubble solution, and the air to the head. (Fig. 1 illustrates the basic features of the head.)

Neutrally buoyant helium-filled bubbles, about 1-millimeter in diameter, form on the tip of the concentric tubes and are blown off the tip by a continuous blast of air flowing through the shroud passage. The bubble solution flows through the annular passage and is formed into a bubble inflated with the helium passing through the inner concentric tube. The desired bubble size and neutral buoyancy are achieved by proper adjustment of air, bubble solution, and helium flow rates. As many as 300 bubbles per second can be formed in this device.

### Rig

The flow visualization test rig, consisting of a transparent plastic tunnel through which ambient room air is drawn into a vacuum exhaust line, is of simple construction providing flexibility for testing a large number of film-injection hole geometries and boundary-layer configurations appropriate to turbine and combustor cooling applications. The test rig configuration (fig. 2) for this report consisted of a zero-pressure-gradient main-stream flow over a flat surface containing discrete film-injection holes. At the point of injection the main-stream boundary layer was fully turbulent. There are three separate airflow sources: (1) the primary main-stream air, (2) the bubble generator air, and (3) the secondary film-injection air.

The tunnel, 0.381 by 0.152 meter in cross section, is sectioned into four parts: a test section 0.61 meter long and three spacing sections each 0.91 meter long. The sections can be put in any order to allow for a boundary-layer development length upstream of the first film injection location anywhere from several centimeters to over 2.7 meters. Having the option of injecting the film air at different axial locations downstream of the inlet provides flexibility in adjusting the boundary-layer thickness-to-hole diameter  $\delta/D$  and the momentum thickness Reynolds number  $Re_\theta$  at the point of injection when the hole diameter can not be changed significantly. The minimum hole diameter is limited to about 1.3 centimeters to avoid excessive bubble breakage in the holes.

The helium-filled bubbles are injected into a plenum which serves as a collection chamber for the bubbles and the film air. The air, seeded with the bubbles, then passes through the film injection holes in the floor of the test section. The small quantity of air used by the bubble generator to blow the bubbles off the tip of the annulus as they form ends up as part of the film air in the plenum. However, this bubble airflow cannot be varied since it is adjusted and then fixed to give optimum bubble formation. Consequently, to provide variable film-injection airflow rates, additional secondary air is also supplied to the plenum. The plenum box is clamped onto the bottom of the test section for easy removal when another test plate with a different hole configuration is to be tested. Rotameters were used to measure the helium and bubble generator airflow rates,

and a hot-wire flowmeter was used in the secondary-air leg for accurate measurement over a wide range of film airflow rates.

When the bubbles pass through the film-injection holes, they are illuminated by high-intensity quartz arc lamp. The resulting reflection of the bubble surface appears as a streak across the photographic film if the exposure is relatively slow. Sometimes two reflections appear on the same bubble giving a double streak. The light beam was directed axially down the tunnel as shown in the sketch in figure 2. With a well-focused and collimated light beam, the bubbles are illuminated as soon as they leave the holes without the beam striking any of the tunnel surfaces. This insures good contrast with a bright bubble streak against a black background.

### Test Section

The 0.38- by 0.61-meter floor of the test section that contains the film injection holes is easily removed to allow bottom plates with different hole configurations to be installed without affecting the rest of the test section or the plenum chamber. The floor and back side of the test section are made of wood and finished glossy black to give maximum contrast with the bubble streaklines. The top and front face are clear plastic.

Three film-injection arrays were studied. Sketches of the three configurations are given in figure 3. They are (1) normal injection with the holes oriented normal to the surface, (2) slanted in-line injection with the holes angled  $30^{\circ}$  to the surface and in-line with the main stream, and (3) compound angle injection with the holes again  $30^{\circ}$  to the surface, but rotated  $45^{\circ}$  laterally to the main stream. In all three cases there were four holes spaced five diameters apart as measured from the hole centerline. The holes formed a staggered array representing the center portion of three rows of holes. In figures 3(b) and (c) the hole axes for both the in-line and compound angle holes make an angle of  $30^{\circ}$  with the plane of the paper. Tubes that extend into the plenum were inserted into the holes in the plate and finished off flush with the test surface to provide a hole length-to-diameter ratio typical of aircraft turbine applications. The delivery tubes for this study had a 1.27-centimeter inside diameter and were 6.35 centimeters long.

## RESULTS AND DISCUSSION

A fully turbulent boundary layer existed in the region of the film injection holes and the free-stream turbulence intensity, measured by a hot-wire probe, was 2 percent. The film-to-main-stream velocity ratio was varied by changing the mass flow rate of the secondary or film air while keeping the main-stream velocity constant at 15.5 meters per second. The velocity profile through the boundary layer was surveyed with a total-

pressure probe just upstream of the injection holes. The dimensionless profile is given in figure 4. Comparing the data with the theoretical curve given by the solid line shows the logarithmic distribution in the wall region that is characteristic of a turbulent boundary on a smooth wall. The boundary-layer thickness, defined by the 99 percent value of the free-stream velocity, was 2.22 centimeters. The boundary-layer-thickness to injection-hole-diameter ratio was then 1.75 at the upstream injection location. The boundary-layer momentum thickness  $\theta$  was 0.215 centimeter, and the shape factor  $H$  was 1.31; so the momentum thickness Reynolds number was 2200 at the upstream hole location.

Photographs of the film streaklines were taken both from the top looking down on the test surface and from the side. The two viewing angles are illustrated in figure 5, which shows the test section with two cameras mounted in position. The top view photographs show the spreading characteristics of the film as it leaves the holes, and the side view photographs show the degree of penetration of the film into the main-stream relative to the boundary-layer thickness and the surface. All of the side view photographs were taken with the two outer holes in the four-hole array plugged to give a plane view of the two center holes. The film from the upstream hole passes directly over the downstream hole. The streaklines in the figures are black on a white background because the photographs in this report are negative images printed from color transparencies.

Normal injection. - Streaklines traced by a film injected into a turbulent boundary layer from holes oriented normal to the surface are shown in figure 6. Nominal blowing rates of 0.3, 0.5, 0.8, and 1.4 are given. For each blowing rate a top view showing all four holes, a side full-field view, and a closeup side view of the upstream hole and the downstream hole are shown. A counter-rotating vortex pattern extending downstream of each injection hole is visible in the top view and also in the closeup view, especially of the upstream hole. This twin vortex pattern has been well documented in earlier studies. At the highest blowing rate ( $m = 1.4$ ) the turbulent mixing is so intense that the streaklines look randomly intertwined and the vortex pattern is not as well preserved. The top view shows that the film spreads to a width of about one and a half hole diameters for a blowing rate of 0.3 and slightly more for the higher blowing rates.

From the side view note that the film separates from the surface and penetrates the boundary layer even at a low blowing rate of 0.3. The boundary-layer thickness  $\delta$  just upstream of the first injection hole is indicated on the side view photograph. At the high blowing rate most of the film mixes with the free stream rather than providing a protective film adjacent to the surface.

Notice in the closeup views the sharp kinks in the streaklines, particularly at the highest blowing rate. The tortuous path traced by a bubble indicates a very-high-intensity, small-scale turbulence structure in the vortex region just downstream of an injection hole. Such high turbulence reduces the effectiveness of the film by increasing the heat-transfer coefficient and promoting rapid mixing of the film air with the main



stream. As the bubbles get caught up in one of the vortices, their trajectory is in a direction nearly normal to the surface, suggesting a very high-velocity transfer of mass between the wall region and the outer boundary layer. There is also evidence of recirculating flow since some of the streaklines slope back upstream.

Slanted in-line injection. - The streakline pattern associated with film injection from holes angled  $30^\circ$  to the surface, in-line with the main stream, is given in figure 7. As with normal injection, blowing rates having nominal values of 0.3, 0.5, 0.8, and 1.4, were photographed in the same top, side, and closeup views. These are the same photographs that appear in reference 10 and are reproduced here for convenience.

Notice that, in general, these streaklines are much smoother than normal injection streaklines, indicating a much larger scale and lower intensity turbulence for  $30^\circ$  injection. Only at the highest blowing rate do the streaklines exhibit the character indicative of high-intensity, small-scale turbulence. The counterrotating vortex pattern is not nearly as evident as it was for the normal-injection case. However, in all but the highest blowing rate case, there is evidence of entrainment of the fluid further from the wall towards the surface in that the streaklines coming from the center of a hole wrap around the outside and then under the jet. The pattern is more subtle than with normal holes because the scale at which the streaklines interwind is much larger - on the order of the hole diameter. The top view shows almost no spreading of the film as it extends downstream until it encounters another injection hole. Then, most of the upstream film tends to split to either side of the downstream jet.

At a blowing rate of 0.3 the film remains very near the surface. (See fig. 7(a).) The thickness of the film layer is much less than the thickness of the boundary layer entering the injection region. However, it has been observed in these and other tests that at a blowing rate of about 0.4 the film jet begins to separate from the surface, allowing the main-stream air to wrap around and under the jets. The separated film layer is evident in the side view in figure 7(b) (blowing rate, 0.5). At the higher blowing rates of 0.8 and 1.4, the film ends up in the free stream, providing very little protection to the surface. Also, as one would expect, the jet from the downstream hole has a steeper trajectory because of the momentum deficit in the boundary layer caused by the upstream injection.

Figure 7(d) shows the downstream jet passing right through the film from the upstream hole. Note also the high turbulence generated at the 1.4 blowing rate compared with the lower blowing rates. When the velocity of the jet exceeds that of the main stream there is a change in the character of the turbulence near the injection holes. When  $m < 1$ , the streaks are smooth and gently undulating; when  $m > 1$ , very jagged streaks appear.

Compound angle injection. - The distinctive features of the streak pattern associated with film injection at a compound angle  $30^\circ$  to the surface and  $45^\circ$  lateral to the main stream are illustrated in figures 8 and 9. For this injection configuration the oblique

angle that the film makes with the main stream generates a single vortex filament downstream of each hole. This vortex motion begins forming at blowing rates of about 0.3 (fig. 8(a)) and becomes most pronounced at blowing rates between 0.7 and 0.9. Notice the very tight "winding" of the streaklines in figure 8(b) for a blowing rate of 0.74. A closeup top view of the region surrounding the upstream injection location for this blowing rate is shown in figure 8(c). The most important feature of compound-angle injection is that this strong vortex motion keeps the film attached to the surface even at the high blowing rates. This can be seen in figure 9, which compares the compound angle injection at low and high blowing rates. Notice that there is very little difference in the penetration distances between a blowing rate of 0.3 and 0.9. Even at a velocity ratio of 0.9, the film remains close to the surface. Note particularly how the downstream film lies under the film from the upstream hole. Recall that in figure 7(c) for the in-line injection, most of the film separated from the surface at a blowing rate of 0.8.

### CONCLUDING REMARKS

In discrete hole film cooling for turbine applications, the film should be injected at as shallow an angle to the surface as possible within the limits set by fabrication constraints. Normal injection is a very inefficient method of film cooling because the film separates from the surface even at low blowing rates. A counterrotating vortex motion downstream of the injection hole generates excessive turbulent mixing which dissipates the film, increases the heat-transfer coefficient, and increases aerodynamic losses in the turbine.

For injection holes angled  $30^{\circ}$  to the surface, in-line with the main stream, the film layer remains attached to the surface as long as the blowing rate does not exceed about 0.5. At higher blowing rates the main stream will wrap around and under the separated film jet, reducing its effectiveness. But high film-injection velocities cannot always be avoided in turbine-cooling applications because of the pressure drop needed across the outer shell of the airfoil to insure that a positive flow direction is always maintained. High blowing rates are a particular problem with multiple rows of film-cooling holes fed from a common supply plenum and discharging into a region of rapidly varying free-stream static pressure.

To delay separation to much higher blowing rates, film-cooling holes can be oriented at a compound angle to the surface and main stream in local areas on the turbine blade where the boundary layer has a tendency to separate, such as in the diffusion region on the suction or convex side of the blade. Where the blowing rate can be kept low, however, in-line injection is preferred because it causes less turbulent mixing. Consequently, the

film persists longer. Also, in-line injection results in a lower aerodynamic penalty in turbine efficiency because most of the momentum of the film jet is recovered.

Lewis Research Center,  
National Aeronautics and Space Administration,  
Cleveland, Ohio, March 3, 1976,  
505-04.

#### REFERENCES

1. Erikson, V. L.: Film Cooling Effectiveness and Heat Transfer with Injection Through Holes. (HTL-TR-102; Minnesota Univ.; NAS3-13200), NASA CR-72991, 1971.
2. Liess, Christian: Film Cooling with Ejection from a Row of Inclined Circular Holes - An Experimental Study for the Application to Gas Turbine Blades. VKI-TN-97, Von Karman Inst. For Fluid Dynamics, 1974.
3. Choe, H.; Kays, W. M.; and Moffat, R. J.: The Superposition Approach to Film Cooling. ASME Paper 74-WA/HT-27, Nov. 1974.
4. Choe, H.; Kays, William M.; and Moffat, Robert J.: The Turbulent Boundary Layer on a Full-Coverage Film-Cooled Surface: An Experimental Heat Transfer Study with Normal Injection. NASA CR-2642, 1976.
5. Crawford, Michael E.; et al.: Full-Coverage Film Cooling Heat-Transfer Studies - A Summary of the Data for Normal-Hole Injection and 30 Slant-Hole Injection. NASA CR-2648, 1976
6. Metzger, D. E.; Takeuchi, D. I.; and Kuenstler, P. A.: Effectiveness and Heat Transfer with Full-Coverage Film Cooling. J. Eng. Power, ASME Trans., ser. A, vol. 95, Jul. 1973, pp. 180-184.
7. Mayle, R. E.; and Camarata, F. J.: Multihole Cooling Film Effectiveness and Heat Transfer. ASME Paper 74-HT-9, July 1974.
8. LeBrocq, P. V.; Launder, B. E.; and Priddin, C. H.: Discrete Hole Injection as a Means of Transpiration Cooling - An Experimental Study. HTS/71/37, Imperial Coll. of Sci. Tech., 1971.
9. Launder, B. E.; and York, J.: Discrete Hole Cooling in the Presence of Freestream Turbulence and a Strong Favorable Pressure Gradient. HTS/73/9, Imperial Coll. of Sci. Tech. 1973.

10. Colladay, Raymond S.; Russell, Louis M.; and Lane, Jan M: Streakline Flow Visualization of Discrete Hole Film Cooling With Holes Inclined  $30^{\circ}$  to Surface. NASA TN D-8175, 1976.
11. Hale, R. W.; et al.: Development of an Integrated System for Flow Visualization in Air Using Neutrally Buoyant Bubbles. SAI-RR-7107, Sage Action, Inc. (AD-756691; TR-2), 1971.

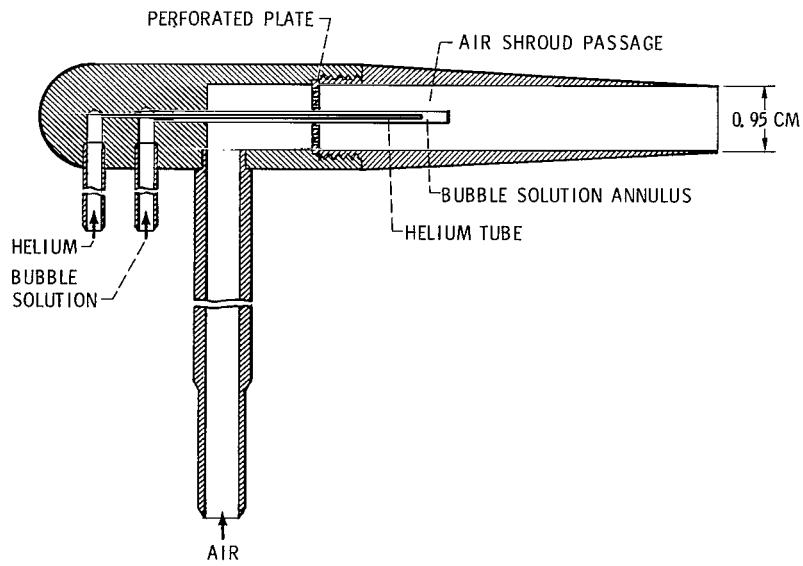

Figure 1. - Bubble generator head.

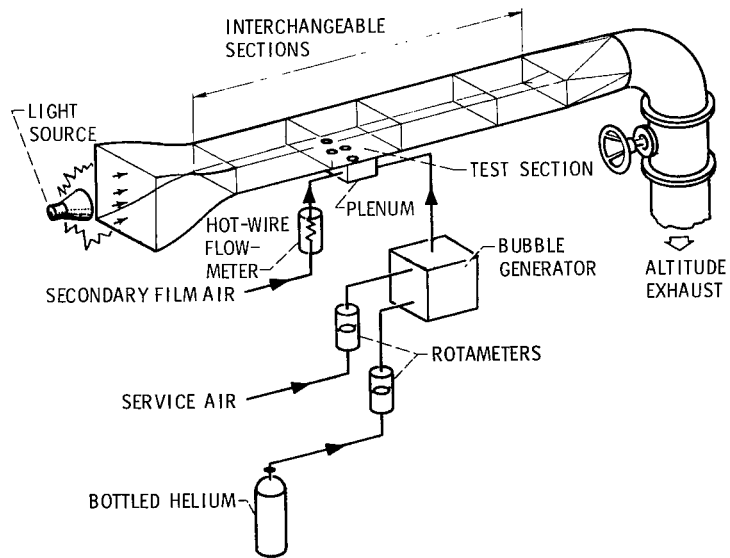

Figure 2. - Film cooling flow visualization rig.

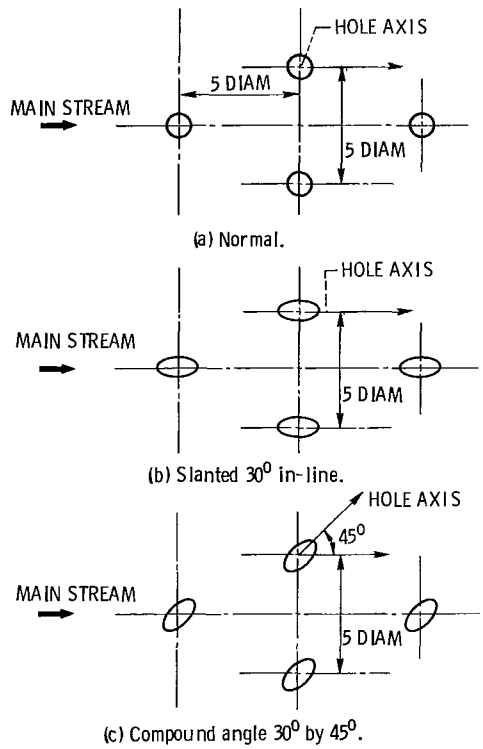

Figure 3. - Top view of the three injection arrays.

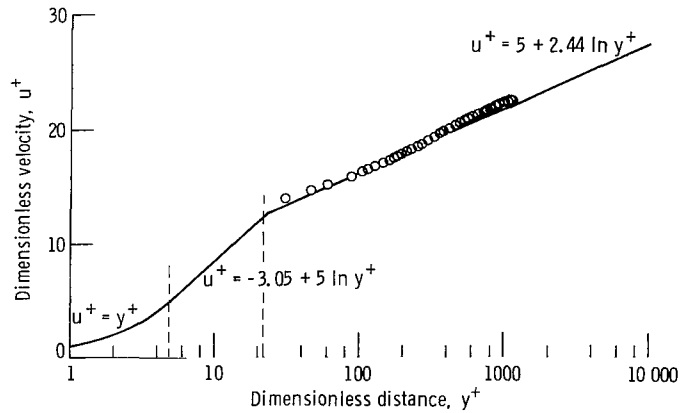

Figure 4. - Boundary-layer profile at upstream injection location.

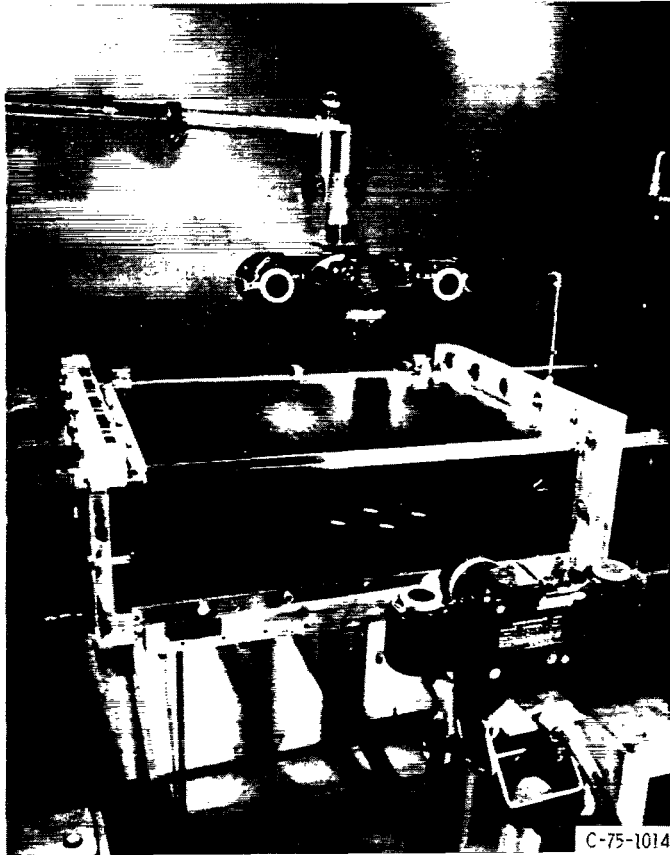
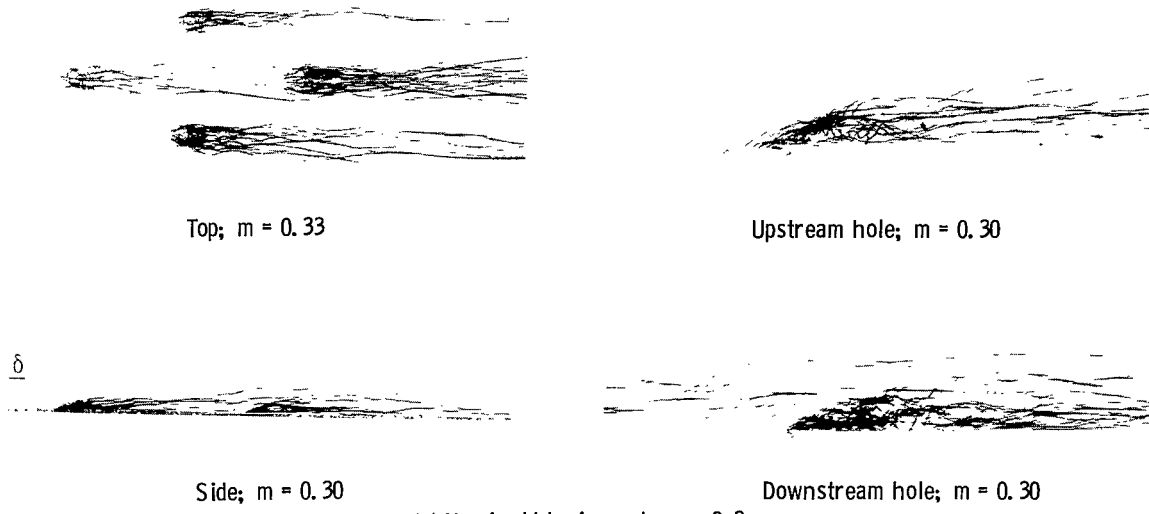
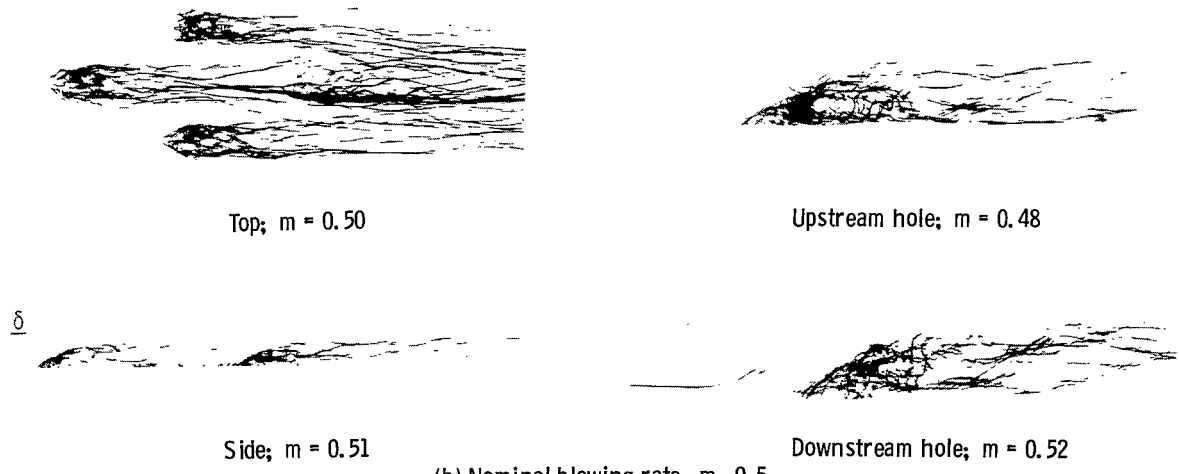

Figure 5. - Test section with top and side view camera positions.



(a) Nominal blowing rate,  $m, 0.3$ .



(b) Nominal blowing rate,  $m, 0.5$ .

Figure 6. - Film streaklines for normal injection.



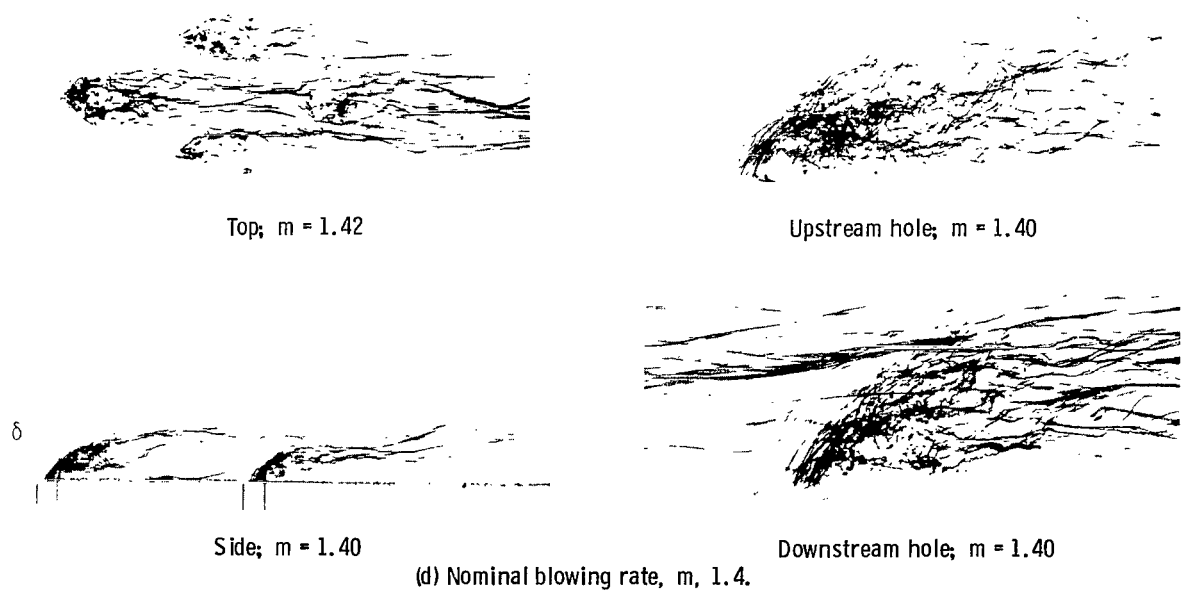
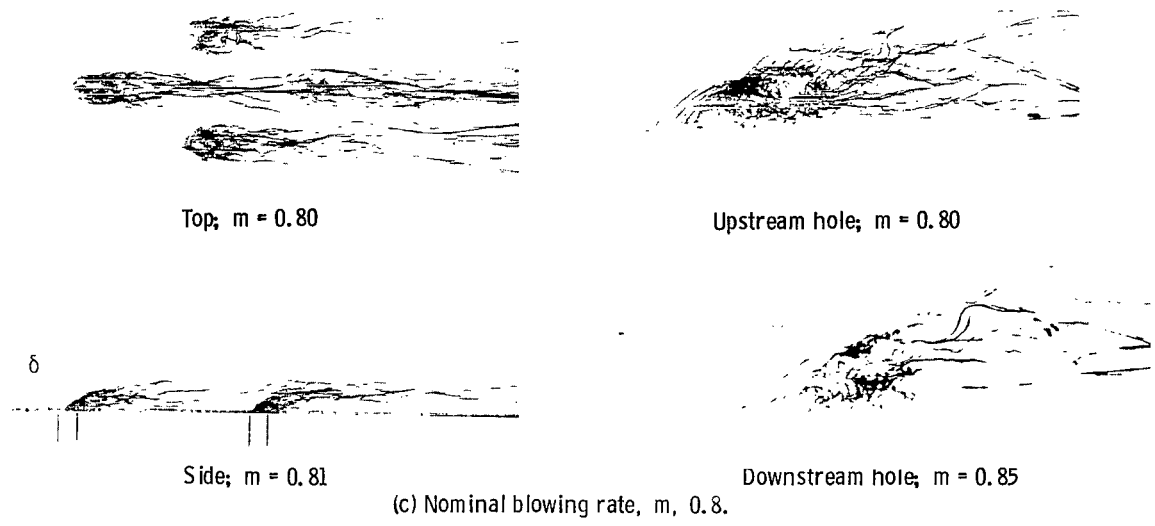

Figure 6. - Concluded.

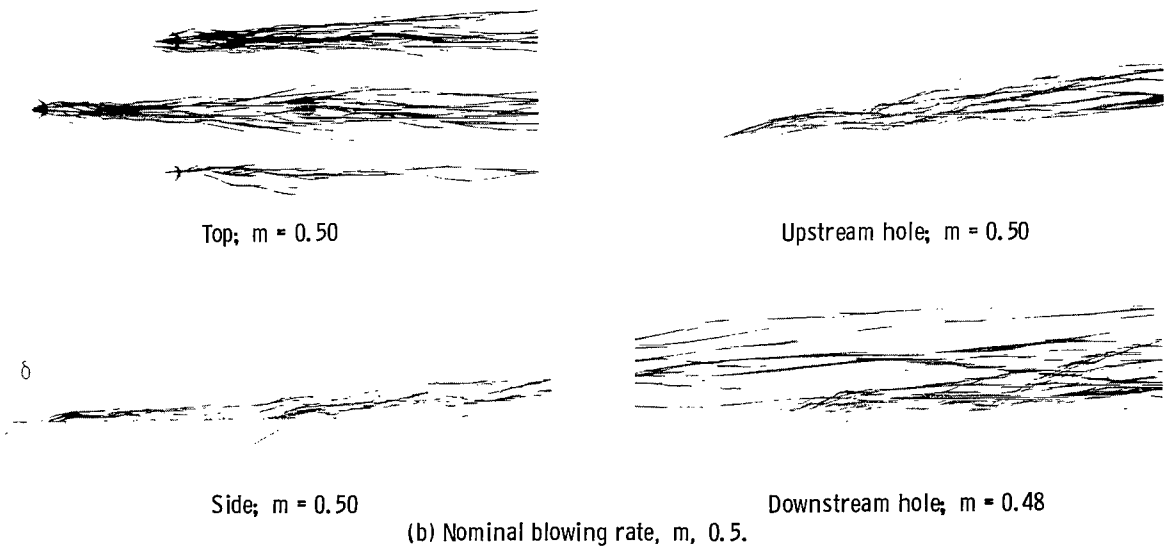
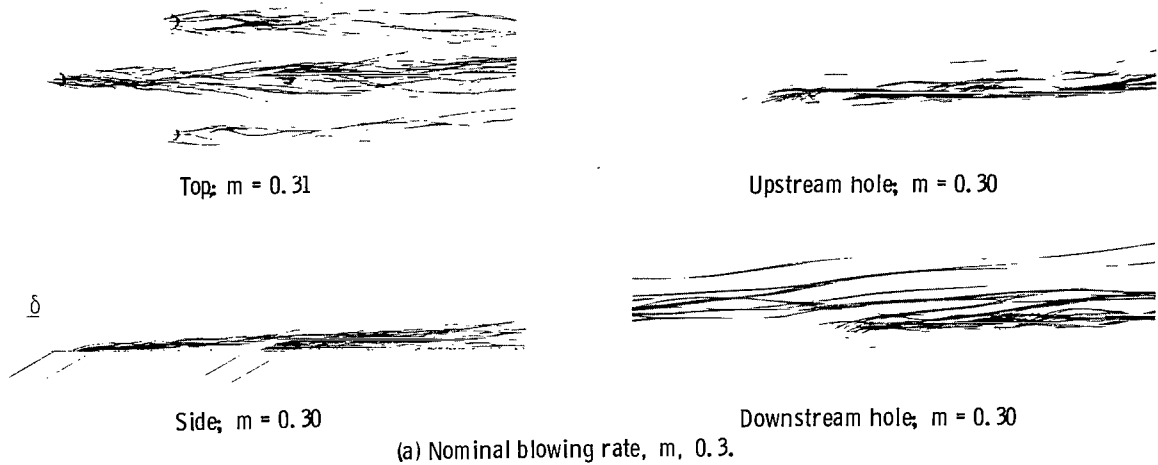

Figure 7. - Film streaklines for  $30^\circ$  injection in line with mainstream.

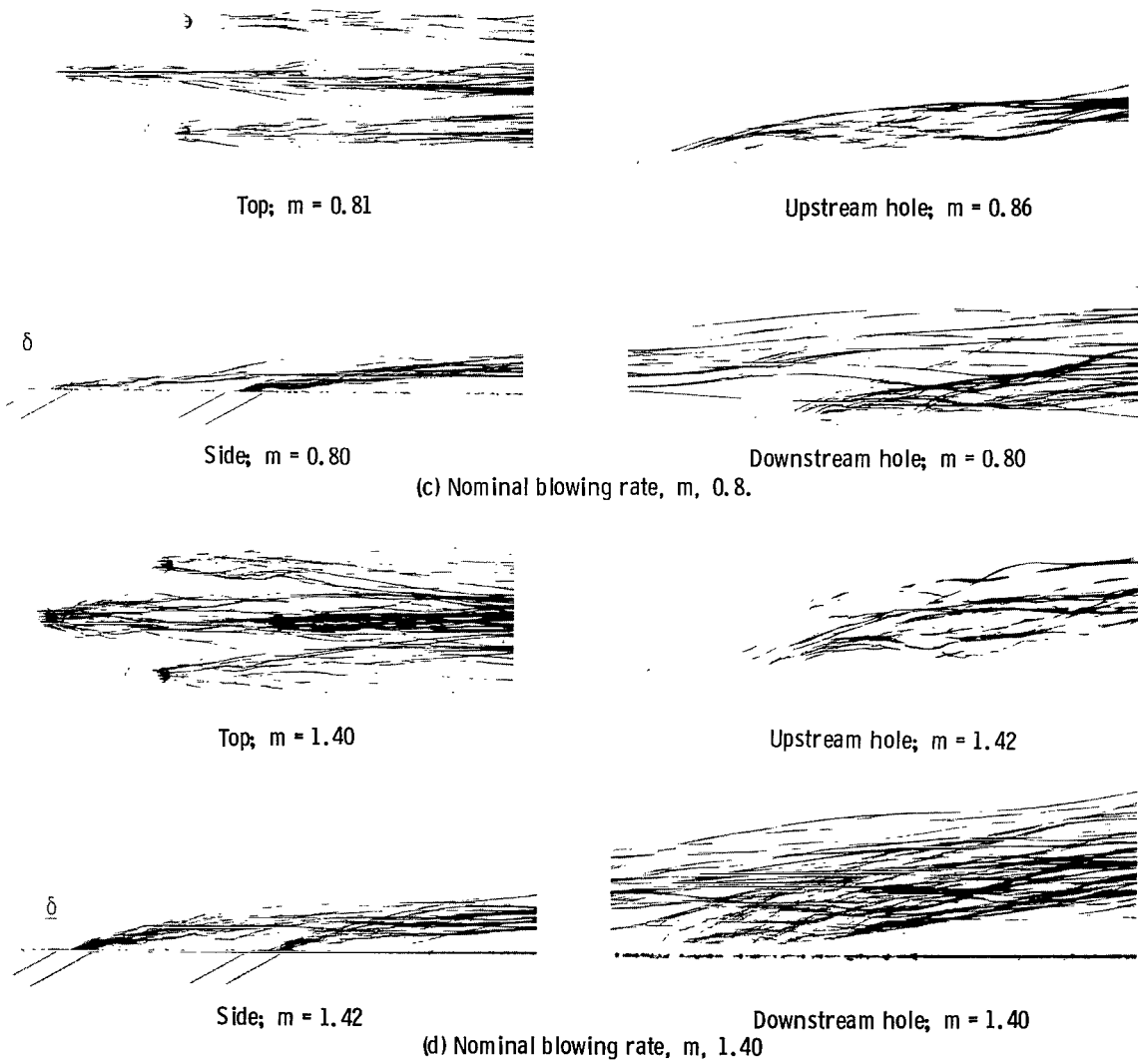

Figure 7. - Concluded.



(a) Blowing rate,  $m$ , 0.29.



(b) Blowing rate,  $m$ , 0.74.



(c) Blowing rate,  $m$ , 0.76

Figure 8. - Film streaklines for compound angle injection; top view.



(a) Blowing rate, 0.30.



(b) Blowing rate, 0.90.

Figure 9. - Film streaklines for compound angle injection; side view.



733 001 C1 U D 760827 S00903DS  
DEPT OF THE AIR FORCE  
AF WEAPONS LABORATORY  
ATTN: TECHNICAL LIBRARY (SUL)  
KIRTLAND AFB NM 87117

POSTMASTER: Undeliverable (Section 158  
Postal Manual) Do Not Return

---

*"The aeronautical and space activities of the United States shall be conducted so as to contribute . . . to the expansion of human knowledge of phenomena in the atmosphere and space. The Administration shall provide for the widest practicable and appropriate dissemination of information concerning its activities and the results thereof."*

—NATIONAL AERONAUTICS AND SPACE ACT OF 1958

## NASA SCIENTIFIC AND TECHNICAL PUBLICATIONS

**TECHNICAL REPORTS:** Scientific and technical information considered important, complete, and a lasting contribution to existing knowledge.

**TECHNICAL NOTES:** Information less broad in scope but nevertheless of importance as a contribution to existing knowledge.

**TECHNICAL MEMORANDUMS:** Information receiving limited distribution because of preliminary data, security classification, or other reasons. Also includes conference proceedings with either limited or unlimited distribution.

**CONTRACTOR REPORTS:** Scientific and technical information generated under a NASA contract or grant and considered an important contribution to existing knowledge.

**TECHNICAL TRANSLATIONS:** Information published in a foreign language considered to merit NASA distribution in English.

**SPECIAL PUBLICATIONS:** Information derived from or of value to NASA activities. Publications include final reports of major projects, monographs, data compilations, handbooks, sourcebooks, and special bibliographies.

**TECHNOLOGY UTILIZATION PUBLICATIONS:** Information on technology used by NASA that may be of particular interest in commercial and other non-aerospace applications. Publications include Tech Briefs, Technology Utilization Reports and Technology Surveys.

*Details on the availability of these publications may be obtained from:*

**SCIENTIFIC AND TECHNICAL INFORMATION OFFICE**

**NATIONAL AERONAUTICS AND SPACE ADMINISTRATION**

**Washington, D.C. 20546**