

Strength of High Manganese Non-magnetic Steel / Carbon Steel Hybrid Girder[†]

– Investigation for Applying Dissimilar Materials to Steel Structures (Report IV)–

HIROHATA Mikihito* and KIM You-Chul**

Abstract

The strength of a hybrid girder with a high manganese non-magnetic (Hi-Mn) steel / carbon (SM490; SM) steel (Hybrid girder) was investigated based on the results of the elastic-plastic large deformation analysis. The yield stress and Young's modulus of Hi-Mn steel were 16% larger and 20% smaller compared with those of SM steel. When the upper half was assembled with Hi-Mn steel and the lower half of the cross section of the Hybrid girder was assembled with SM steel, the yielding moment was 2% and 18% larger than those of the girder with only Hi-Mn steel and the girder with only SM steel. The bending stiffness was 8% larger and 11% smaller than those of Hi-Mn and SM girders. The out-of-plane deformation of the web was larger than those of Hi-Mn and SM girders. By moving the position of the horizontal stiffener of the Hybrid girder 10% lower, the out-of-plane deformation of the web was controlled to smaller than those of Hi-Mn and SM girders.

KEY WORDS: (Hybrid Structure), (Magnetically Levitated Vehicle), (Non-magnetic Steel), (Dissimilar Steel), (Young's modulus)

1. Introduction

Recently, research and development of magnetically levitated vehicles as new high-speed transportation systems have been advanced¹⁾. The magnetically levitated vehicle runs by repulsion between superconductive magnets on the vehicle and coils on the railway. However, when ordinary steel is used for the girder as the guide way, it is known that a loss of energy occurs by magnetic resistance force. Although non-magnetic steel needs to be used, it is more expensive than the ordinary steel. Therefore, it is proposed that non-magnetic steel is used only in the area where magnetism is generated and ordinary steel is used in the other areas where magnetism is not generated.

A series of researches has been carried out for application of ordinary carbon steel and non-magnetic steel in the hybrid steel structures. The mechanical properties and the fatigue strength of the welded joints with high manganese non-magnetic steel / the carbon steel were examined^{2), 3)}. The compressive characteristics of cruciform columns assembled with high manganese non-magnetic steel / carbon steel were examined by experiment and simulated by elastic-plastic large deformation analysis⁴⁾.

In this paper, in order to propose that the hybrid structure assembled with high manganese non-magnetic

steel / carbon steel is applied for the guide way of the magnetically levitated vehicles, the strength of the hybrid steel girder is examined based on the results of elastic-plastic large deformation analysis.

2. Structural Characteristics of High Manganese Non-magnetic Steel / Carbon Steel Hybrid Girder

Here, the basic structural parameters of the hybrid girder are investigated. By comparing them with those of the girders assembled with only the high manganese non-magnetic steel or the carbon steel, the structural characteristics of the hybrid girder are elucidated.

2.1 Mechanical properties of materials

As materials assembling the hybrid girder, high manganese non-magnetic (Hi-Mn) steel and SM490Y (SM) steel which is one of the generally used carbon steels, are selected.

In order to elucidate the mechanical properties of these materials, tensile tests were carried out. Fig. 1 shows the results of tensile tests and Table 1 shows the mechanical properties of these materials. The yield stress of Hi-Mn steel is 16% larger compared with that of SM steel. The tensile strength of Hi-Mn steel is twice as large as that of SM steel. However, Young's modulus of Hi-Mn steel is about 80% of that of SM steel.

[†] Received on July 10, 2009

* Specially Appointed Assistant Professor

** Professor

Transactions of JWRI is published by Joining and Welding Research Institute, Osaka University, Ibaraki, Osaka 567-0047, Japan

Strength of High Manganese Non-Magnetic Steel / Carbon Steel Hybrid Girder

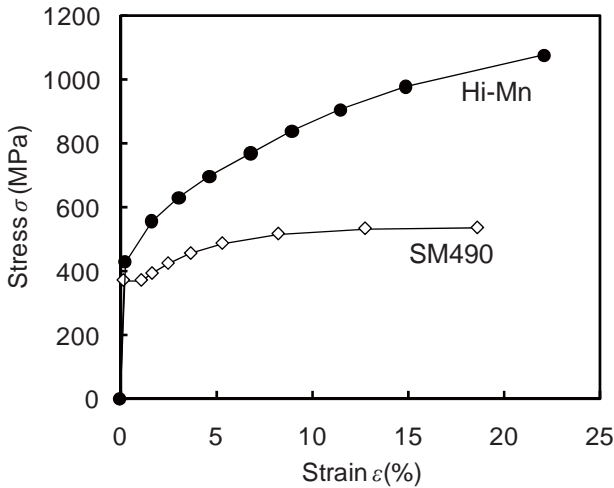

Fig. 1 Results of tensile tests.

Table 1 Mechanical properties of materials.

	Hi-Mn	SM490
Young's modulus E (GPa)	165	200
Yield stress σ_Y (MPa)	429	371
Tensile strength σ_U (MPa)	1076	535
Strain at tensile strength ε_U (%)	22.1	18.6

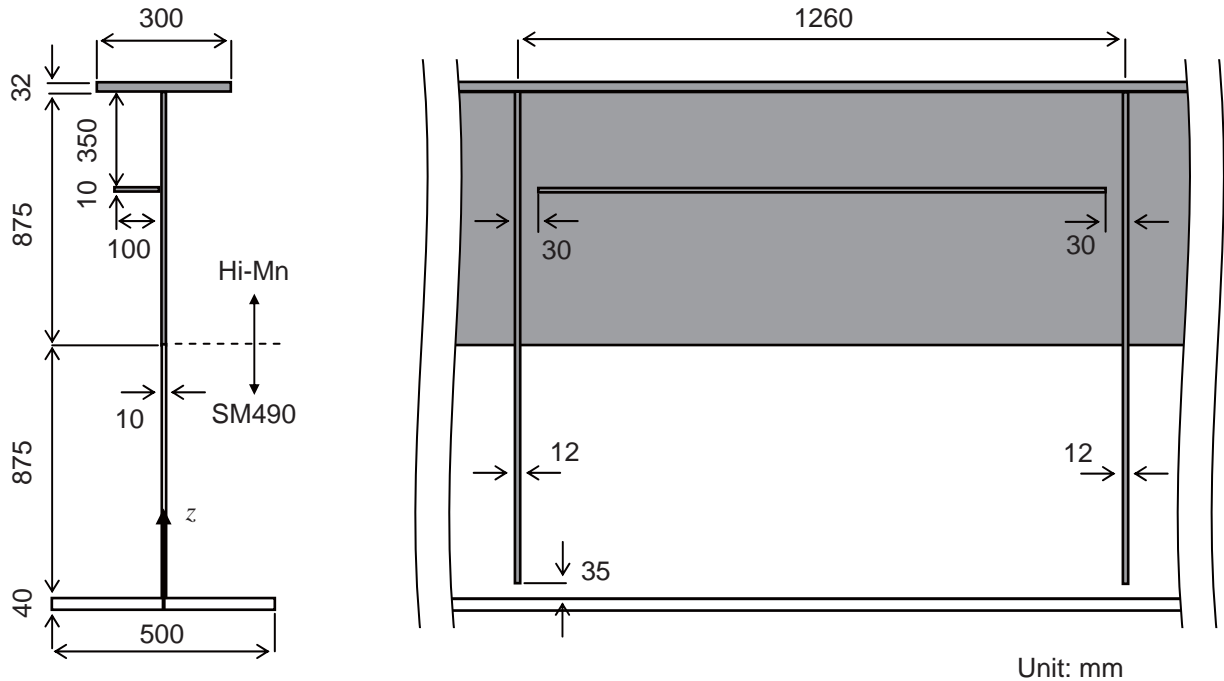

Fig. 2 Shape and dimension of Hybrid-1 girder.

2.2 Shape and dimension of girder

Fig. 2 shows the shape of the cross section and the dimensions of the hybrid girder assembled with Hi-Mn / SM steel (the Hybrid-1 girder). The shape of the cross section is I-shape. The dimension is decided by satisfying Specification for Highway Bridges in Japan⁵⁾, because the details of design for the girder used for the magnetically levitated vehicle is not decided at present. A horizontal stiffener is attached to web at 20% of the web height from the upper flange.

The structural characteristics of the Hybrid-1 girder are compared with those of a Hi-Mn girder, whose material in all parts is only Hi-Mn steel, and a SM girder, whose material in all parts are only SM steel.

2.3 Structural characteristics of hybrid girder

The structural parameters of the Hybrid-1 girder are calculated as follows.

The ratio of Young's modulus of Hi-Mn and SM steel, n , is calculated by Eq. (1).

$$n = E_{Mn} / E_{SM} \quad (1)$$

Where, E_{Mn} and E_{SM} are Young's moduli of Hi-Mn and SM steel respectively. By using the values shown in Table 1, $n=0.82$.

By considering the difference of Young's modulus, the position of neutral axis, z_G , is calculated by Eq. (2). For calculating z_G , the equivalent cross sectional area, A^* , and the geometrical moment of area, G^* are required. They are calculated by Eq. (3) and (4).

$$z_G = G^* / A^* \quad (2)$$

$$A^* = nA_{Mn} + A_{SM} \quad (3)$$

$$G^* = n \int_{A_{Mn}} z dA + \int_{A_{SM}} z dA \quad (4)$$

Where, A_{Mn} is the sectional area of the part with Hi-Mn steel in the cross section, A_{SM} is that with SM steel. However, the horizontal and vertical stiffeners are not considered in these areas.

The moment of inertia of section, I^* , based on SM steel is calculated by Eq. (5).

$$I^* = n \int_{A_{Mn}} z^2 dA + \int_{A_{SM}} z^2 dA - z_G^2 A^* \quad (5)$$

In Eq. (5), the first term is the moment of inertia of the section composed with Hi-Mn steel and the second term is that composed with SM steel. Based on SM steel, the bending stiffness of the Hybrid-1 girder is obtained by multiplying E_{SM} and I^* .

The distribution of applied stress at the section, $\sigma_x(z)$, due to bending moment, M , is obtained by Eq. (6) or (7).

In the part composed with Hi-Mn steel;

$$\sigma_x(z) = n \frac{M}{I^*} (z_G - z) \quad (6)$$

In the part composed with SM steel;

$$\sigma_x(z) = \frac{M}{I^*} (z_G - z) \quad (7)$$

When the stress at the upper edge ($z=H$; H is the height of girder) or the lower edge ($z=0$) is equal to the yield stress of the material in the upper or lower flange, the section starts to yield. The bending moment at that time, M_y , which is the yielding moment, is obtained by Eq. (8) or (9).

In the case that the upper edge composed with Hi-Mn steel is initially yielded;

$$M_y = \frac{\sigma_{YMn} I^*}{n(H - z_G)} \quad (8)$$

In the case that the lower edge composed with SM steel is initially yielded;

$$M_y = \frac{\sigma_{YSM} I^*}{z_G} \quad (9)$$

Where, σ_{YMn} is the yield stress of Hi-Mn steel and σ_{YSM} is that of SM steel.

It is determined whether the upper or lower part is initially yielded by the yield stress of each material and the location of neutral axis, z_G .

Table 2 shows the structural parameters of Hybrid-1, Hi-Mn and SM girders.

The position of the neutral axis, z_G , of the Hybrid-1 girder is a little lower than those of the Hi-Mn and SM girders due to the difference of Young's modulus of Hi-Mn and SM steels.

Table 2 Structural parameters of girders.

	Hybrid-1	Hi-Mn	SM
Neutral axis z_G (mm)	652	717	717
Moment of inertia $I (\times 10^8 \text{mm}^4)$	234	263	263
Bending stiffness $EI (\times 10^{13} \text{N}\cdot\text{mm}^2)$	467	433	525
Yielding moment M_y (MN·m)	10.4	10.2	8.8

The bending stiffness, EI , of the Hi-Mn girder is about 80% of that of SM girder. The difference corresponds to the difference of Young's modulus of Hi-Mn and SM steel. The bending stiffness, EI , of the Hybrid-1 girder is between those of the Hi-Mn and SM girders. The yielding moment, M_y , of Hybrid-1 girder is 2% and 18% larger than those of Hi-Mn and SM girders.

3. Strength of High Manganese Non-magnetic Steel / Carbon Steel Hybrid Girder

Here, the elastic-plastic large deformation analysis^{4), 7), 8)} is carried out on the Hybrid-1, Hi-Mn and SM girders. By comparing the results of analysis, the strength of the high manganese non-magnetic steel / the carbon steel hybrid girder is elucidated. Whether the strength of the hybrid girder can be explained by the structural parameters calculated in chapter 2 or not is examined.

3.1 Model for analysis

Fig.3 shows the configuration of the model for analysis.

The noted region in the middle of the span ($0 \leq x \leq 5040$) is modeled by 4-nodes shell elements and the other parts are modeled by beam-column elements with I-shape cross section. In the beam-column elements, the vertical and horizontal stiffeners are not considered.

The displacement in the x direction and the rotation around the y -axis of all the nodal points at $x=0$ of shell elements are decided as uniform. In the part at which the shell and beam-column elements are jointed, it is considered that the displacements between the two kinds of elements are continuous at $y=0$ and $z=0$. At $x=5040$, they are decided in the same way.

The relation between stress and strain of the materials used in the analysis is modeled by the multi linear shape based on the result of the tensile test shown in Fig. 1.

The initial deflection is shown as Eq. (10) and it is applied to each web panel divided by vertical stiffeners.

$$y_0 = \sum A_{0mn} \sin \frac{m\pi x}{a} \sin \frac{n\pi z}{b_w} \quad (10)$$

Where, the absolute value of the initial deflection is $A_{0mn}=0.1(\text{mm})$; the number of waves are $m=1, n=1, 2$ and 3 ; the length of each web panel is $a=1260(\text{mm})$; the height of web panel is $b=1750(\text{mm})$.

The welding residual stress is not considered in the analysis.

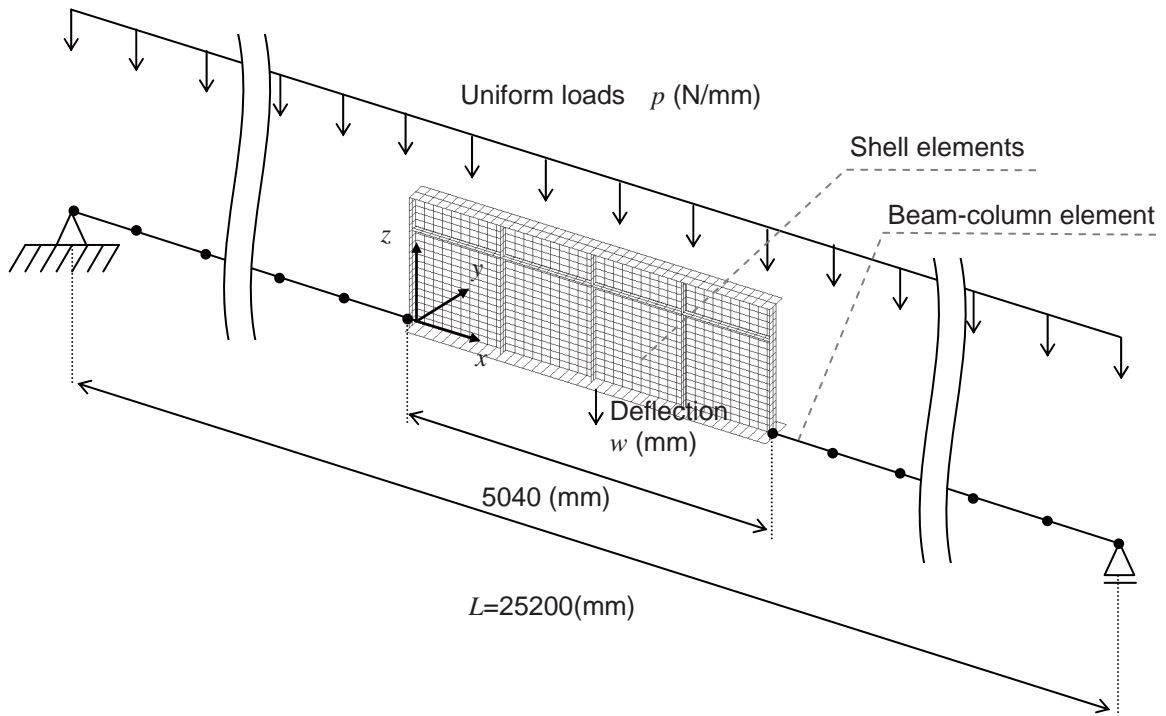

Fig. 3 Configuration of model for analysis.

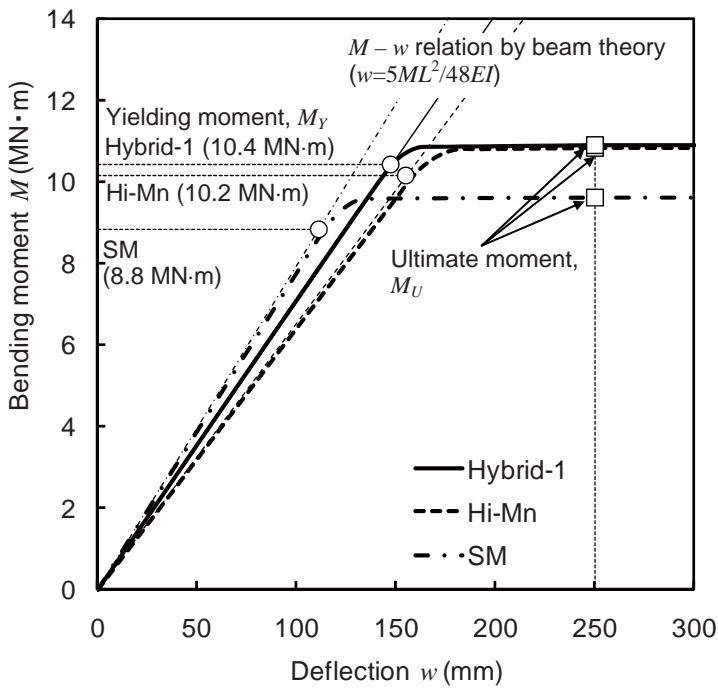

Fig. 4 Relation between bending moment and deflection.

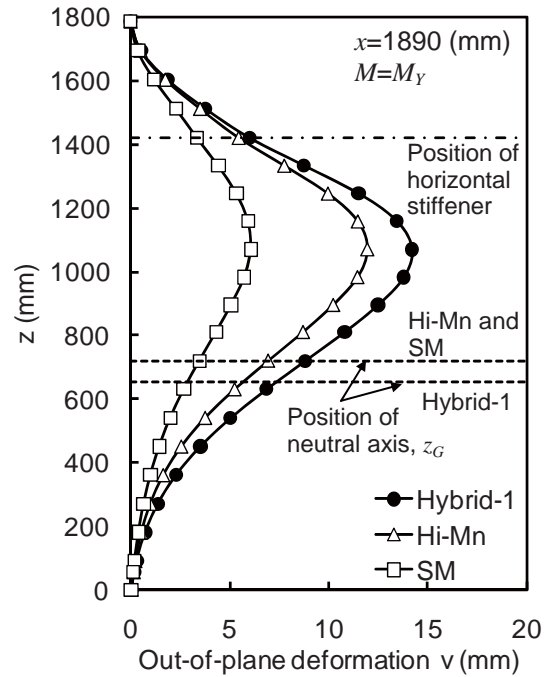

Fig. 5 Out-of-plane deformation mode of web.

3.2 Results of analysis

Fig. 4 shows the relations between the applied moment in the section, M , and the deflection, w , at the center of the span.

The thick lines represent the M - w relations of the Hybrid-1, Hi-Mn and SM girders. Based on the beam theory, the applied moment in the section, M , at the center of the span is calculated as Eq. (11).

$$M = \frac{pL^2}{8} \quad (11)$$

The fine lines represent the M - w relations calculated by the beam theory as Eq. (12). The initial gradients of the M - w relations obtained by the analysis agree with those by the beam theory.

$$w = \frac{5ML^2}{48EI} \quad (12)$$

In the Hybrid-1, Hi-Mn and SM girders, after the applied moments, M , reaches the yielding moments by the beam theory, M_Y (symbol; \bigcirc), the gradients of the $M-w$ relations start to decrease.

Because the load is applied by load control, the maximum moment cannot be defined clearly. Therefore, the ultimate state is defined when the deflection at the center of the span, w , reaches 250 (mm) because the applied moment does not increase after that. The applied moment at that time is defined as the ultimate moment, M_U (symbol; \square). The ultimate moment of the Hybrid-1 girder is similar to that of the Hi-Mn girder. The ultimate moments of the Hybrid-1 and Hi-Mn girders are 15% larger than that of the SM girder.

Fig. 5 shows the mode of the out-of-plane deformation of the web, v ($x=1890\text{mm}$), when the applied moment reaches the yielding moment, M_Y .

The out-of-plane deformation, v , of the web of the Hi-Mn girder (symbol; \triangle) is larger than that of the SM girder (symbol; \square) due to the difference of the bending stiffness, EI . However, although the bending stiffness, EI , of the Hybrid-1 girder is between those of the Hi-Mn and SM girders, the out-of-plane deformation, v , of the Hybrid-1 girder (symbol; \bullet) is larger than those of the Hi-Mn and SM girders (symbol; \triangle and \square).

The position of the neutral axis, z_G , of the Hybrid-1 girder is a little lower than those of the Hi-Mn and SM girders. Therefore, the region applying the compressive stress of the Hybrid-1 girder is larger than those of the Hi-Mn and SM girders under the bending moment. As a result, the out-of-plane deformation of the web, v , of the Hybrid-1 girder is larger than those of the Hi-Mn and SM girders.

In any case, it is confirmed that the strength of the Hybrid-1 girder can be explained by the structural parameters calculated in chapter 2.

3.3 Control of out-of-plane deformation of hybrid girder

The out-of-plane deformation of the web, v , of the Hybrid-1 girder is larger than those of the Hi-Mn and SM girders because the region applying the compressive stress of the Hybrid-1 girder is larger than those of the Hi-Mn and SM girders due to the difference of the position of the neutral axis, z_G .

The out-of-plane deformation of the web, v , of Hybrid-1 girder should be controlled. It should be the middle of those of the Hi-Mn and SM girders at least.

In order to control the out-of-plane deformation of the web, v , of the Hybrid-1 girder, moving the position of the horizontal stiffener is proposed.

It is decided that the horizontal stiffener is attached to the position of 20% of the web height from the top of the web in the case of the girder assembled with the same kind of steel (in the case of the girder in this study, $z=1420$ (mm)). However, it is not proper necessarily in the case of the girder assembled with the dissimilar steels. Therefore, it is proposed that the horizontal stiffener is attached to the position of 30% of the web height from

the top of the web ($z=1245$ (mm)) so that the horizontal stiffener locates the center of the region applying the compressive stress in the web of the Hybrid-1 girder. The new girder is described as a Hybrid-2 girder.

The elastic-plastic large deformation analysis is carried out on the Hybrid-2 girder.

Fig. 6 shows the $M-w$ relations. Fig. 7 shows the mode of the out-of-plane deformation of the web, v , ($x=1890\text{mm}$) when the applied moment reaches the yielding moment, M_Y .

The bending stiffness, EI , the yielding moment, M_Y , and the ultimate moment, M_U , of the Hybrid-2 girder are the same as those of the Hybrid-1 girder. However, the out-of-plane deformation of the web, v , of the Hybrid-2 girder is more controlled compared with that of the Hybrid-1 girder. The out-of-plane deformation of the web, v , of the Hybrid-2 girder is smaller than that of the SM girder. The effect of moving the position of the horizontal stiffener is confirmed.

4. Conclusions

For application of a hybrid structure assembled with high manganese non-magnetic (Hi-Mn) steel and carbon (SM490; SM) steel for the guide way of the magnetically levitated vehicle, the strength of the hybrid girder was elucidated based on the results of the elastic-plastic large deformation analysis.

The main results obtained are as follows.

The yield stress and Young's modulus of Hi-Mn steel were 16% larger and 20% smaller compared with those of SM steel. When the upper half was assembled with Hi-Mn steel and the lower half of the cross section of the girder was assembled with SM steel (a Hybrid-1 girder);

- (1) The position of the neutral axis of the Hybrid-1 girder located lower than that of the girder assembled with only Hi-Mn steel (Hi-Mn girder) or only SM steel (SM girder).
- (2) The bending stiffness of the Hybrid girder-1 was 8% larger and 11% smaller than those of the Hi-Mn and SM girders.
- (3) The yielding moment of the Hybrid-1 girder was 2% and 18% larger than those of the Hi-Mn and SM girders.
- (4) The ultimate moment of the Hybrid-1 girder was similar to that of the Hi-Mn girder and 15% larger than that of the SM girder.
- (5) The out-of-plane deformation of the web of the Hybrid girder-1 was larger than those of the Hi-Mn and SM girders.
- (6) In order to control the out-of-plane deformation of the web of the Hybrid-1 girder, it was proposed that the position of the horizontal stiffener was moved 10% lower so that it located in the center of the region applying the compressive stress in the web (and this is described as a Hybrid-2 girder). As a result, the out-of-plane deformation of the web of the Hybrid-2 girder was smaller than those of the Hi-Mn and SM girders.

Strength of High Manganese Non-Magnetic Steel / Carbon Steel Hybrid Girder

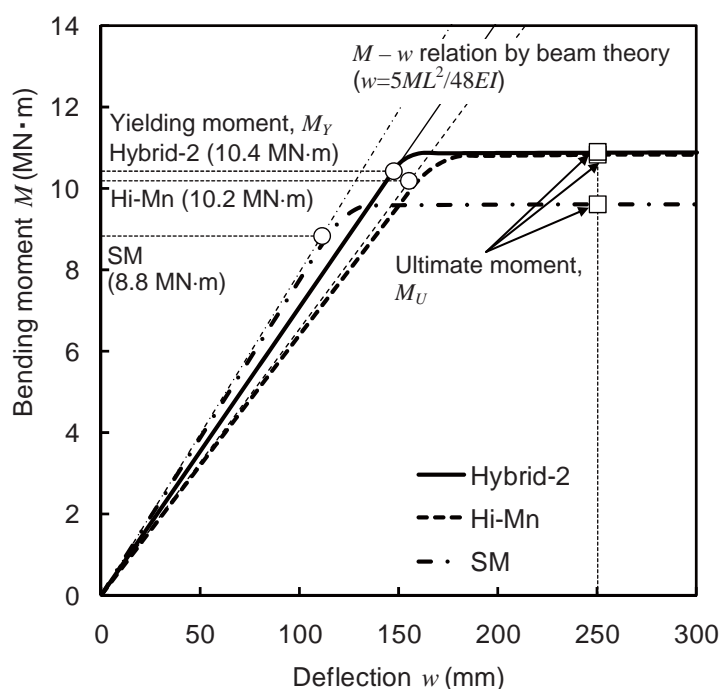

Fig. 6 Relation between bending moment and deflection.

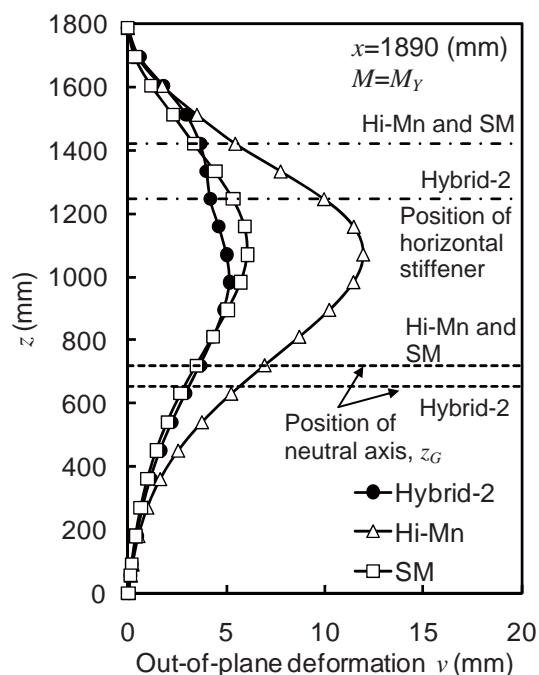

Fig. 7 Out-of-plane deformation mode of web.

References

- 1) Ichikawa, A., Murata, K., Anami, G. and Sugiura, A. 1994. Study on Application of Austenitic High Manganese Steel to Maglev Guideway. *Steel Construction Engineering*, 1-1, pp.63-72.
- 2) Nakaji, E., Ikeda, S., Kim, Y.-C., and Horikawa, K. 1998. Mechanical Properties of High Manganese Non-Magnetic Steel and Carbon Steel Welded Butt Joints. – Investigation for Applying Dissimilar Materials to Steel Structures (Report I) –. *Transactions of JWRI*, 27-2, pp.115-118.
- 3) Nakaji, E., Kim, Y.-C., Nakatsuji, Y. and Horikawa, K. 1999. Fatigue Strength of High Manganese Non-Magnetic Steel and Carbon Steel Welded Butt Joints. – Investigation for Applying Dissimilar Materials to Steel Structures (Report II) –. *Transactions of JWRI*, 28-1, pp.61-66.
- 4) Kim, Y.-C., Tahara, H., Nakaji, E. and Horikawa, K. 1999. Buckling Characteristics of High Manganese Non-Magnetic Steel and Carbon Steel Hybrid Cruciform Columns. – Investigation for Applying Dissimilar Materials to Steel Structures (Report III) –. *Transactions of JWRI*, 28-2, pp.67-74.
- 5) Japan Road Association. 2002. Specifications for Highway Bridge Part II: Steel Bridge, Maruzen, Tokyo.
- 6) Kim, Y.-C., Tahara, H., Nakaji, E. and Horikawa, K. 1997. Buckling Characteristics of High Manganese Non-magnetic Steel and Carbon Steel Hybrid Cruciform Column. *Steel Construction Engineering*, 5, pp.117-124.
- 7) Olaru, D. V., Fujikubo, M., Yanagihara, D. and Yao, T. 2001. Ultimate Strength of Girder Subjected to Shear/Bending Loads. *The Journal of the Kansai Society of Naval Architects*, No. 235, pp. 133-143.
- 8) Yao, T., Astrup, O. C., Caridis, P. A., Chen, Y. N., Cho, R. S., Dow, R. S., Hiho, O. and Rgo, P. 2000. Report of Special Task Committee Vol. 2: Ultimate Hull Girder Strength. *Proc. 14th International Ship and Offshore Structures Congress*, Nagasaki, Japan, 2-6, October, Vol. 2, pp. 321-391.