

N 8 9 - 1 8 5 2 5

**STUDIES AND ANALYSES
OF THE
SPACE SHUTTLE MAIN ENGINE**

Contract No. NASw-3737

FINAL REPORT

BCD-SSME-TR-87-3

December 31, 1987

A. E. Tischer and R. C. Glover

Prepared For

**National Aeronautics and Space Administration
George C. Marshall Space Flight Center
Marshall Space Flight Center, AL 35812**

BATTELLE

**Columbus Division
505 King Avenue
Columbus, Ohio 43201-2693**

STUDIES AND ANALYSES OF THE SPACE SHUTTLE MAIN ENGINE

Contract No. NASw-3737

FINAL REPORT

BCD-SSME-TR-87-3

December 31, 1987

A. E. Tischer and R. C. Glover

Prepared For

National Aeronautics and Space Administration
George C. Marshall Space Flight Center
Marshall Space Flight Center, AL 35812

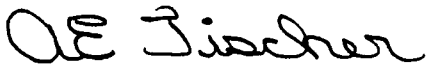

A. E. Tischer
Manager
SSME Study



N. H. Fischer
Manager
Space Systems Section

BATTELLE
Columbus Division
505 King Avenue
Columbus, Ohio 43201-2693

This report is a work prepared for the United States by Battelle. In no event shall either the United States or Battelle have any responsibility or liability for any consequences of any use, misuse, inability to use, or reliance upon the information contained herein, nor does either warrant or otherwise represent in any way the accuracy, adequacy, efficacy, or applicability of the contents hereof.

ABSTRACT

This report documents all of the activities on Contract No. NASw-3737. This contract was initiated in July 1983 and extended through December 1987. The primary objectives of this study were to: evaluate ways to maximize the information yield from the current Space Shuttle Main Engine (SSME) condition monitoring sensors, identify additional sensors or monitoring capabilities which would significantly improve SSME data, and provide continuing support of the Main Engine Cost/Operations (MECO) model. In the area of SSME condition monitoring, the principal tasks were a review of selected SSME failure data, a general survey of condition monitoring, and an evaluation of the current engine monitoring system. A computerized data base was developed to assist in modeling engine failure information propagations. Each of the above items is discussed in detail in this report. Also included is a brief discussion of the activities conducted in support of the MECO model.

EXECUTIVE SUMMARY

The National Aeronautics and Space Administration (NASA) is currently funding a number of research programs in condition monitoring. The primary goals of these efforts are to increase the safety and reliability of the Space Shuttle and to reduce the cost associated with vehicle turnaround. This study provides an independent assessment of the condition monitoring priorities for the Space Shuttle Main Engine (SSME) and evaluates potential improvements to the present SSME condition monitoring system.

Study Supports SSME Development and Operation

The objectives of this study, performed from July 1983 through December 1987, were directed at generating results which would support program planning for improved SSME condition monitoring. The study included both flight and ground test operations. Specifically, the study objectives were:

- Evaluate ways to maximize the information yield from the current SSME condition monitoring sensors
- Identify additional sensors or monitoring capabilities which would significantly improve engine data.

Reviewed SSME Failure Data and Surveyed Status of Condition Monitoring

The review of SSME failure information concentrated on the Unsatisfactory Condition Reports (UCRs) generated and tracked by Rocketdyne from January 1980 through November 1983. This activity included collection and reduction of the UCRs to determine SSME failure modes, categorization of the failure modes, ranking of the failure modes, identification and evaluation of measurable parameters for each failure mode, and identification of parameters for possible trending of engine condition. This review established an understanding of the SSME operating characteristics and failure modes.

The condition monitoring survey included devices and approaches for collecting, processing, and interpreting degradation and/or failure

information. The task determined the status of condition monitoring in the areas of liquid rocket engines, aircraft gas turbines, and heavy machine industries (refining, power generation, etc.). This survey identified new diagnostic sensors, signal processing techniques, and condition monitoring approaches which might be useful for the SSME.

Developed Failure Information Propagation Model Data Base and Modeled SSME Components

A data base and supporting software was developed to store, maintain, and manipulate failure information propagation data for major SSME components. The information generated and entered in this data base is part of a systematic evaluation of failure data available at various test points in the component. The data base can be used to evaluate ways to extract additional condition monitoring information from the current engine sensors. The data base can also be used to analyze potential locations for new sensors.

A complete failure information propagation model (FIPM) was developed for the high-pressure oxidizer turbopump (HPOTP). The HPOTP FIPM consists of a drawing of the turbopump and a set of data base files containing all of the information generated for this engine component. The HPOTP FIPM consists of 105 modules (piece parts or functions), 198 connections, 260 failure modes, and 8213 failure information propagations.

FIPM drawings were also prepared for the following engine components: high-pressure fuel turbopump, low-pressure oxidizer turbopump, low-pressure fuel turbopump, heat exchanger, oxidizer preburner, fuel preburner, main injector, main combustion chamber, and nozzle.

Results and Conclusions Emphasize Continued Development of Specialized SSME Sensors and Techniques

Turbopumps Have High-Priority for Condition Monitoring. The review of the SSME failure data included in this study indicated that the engine turbopumps are very high on the list of components to be monitored. A major item of interest in the turbopumps is the condition of the bearings. This review also indicated that there is a distinct division between monitoring for safety and maintenance purposes. This distinction

is the result of the time constants involved in major engine failures. Most failure modes currently cannot be detected early enough to safely shut down the engine. Hydrogen leak detection was also shown to be a major area of concern from the standpoint of engine turnaround and launch processing.

SSME Represents State of the Art in Rocket Engine Condition Monitoring. The survey of condition monitoring found no sensors or techniques associated with other rocket engines which would improve the availability of SSME degradation/failure information. However, several promising techniques such as gas-path analysis and pattern recognition could provide future improvements in engine monitoring. Improvements in computer processing speed would be required before these approaches could be used in flight. Image processing was identified as a means for improving the quality of internal visual inspections conducted on SSME components.

Integrated System Needed to Track and Analyze SSME Condition Data. A major finding of this study was the need for an integrated system to store, evaluate, and report information related to SSME condition monitoring. This system must include both the flight and ground test operations conducted by NASA and Rocketdyne. Once collected, the information must be reviewed and analyzed to identify significant trends or patterns which indicate engine condition. This data tracking system must include historical data on engine operations and performance.

FIPM Useful in Evaluating Engine Monitoring Requirements. The FIPM approach was successfully modified to model the flow of information in the SSME components. The data base format allowed a substantial amount of data to be stored and manipulated. The records contained in the data base were used to analyze the failure information detectable by current HPOTP sensors and to evaluate several locations for new monitoring devices.

Recommendations Encourage Continued Research and Development of SSME Condition Monitoring System

The recommendations provided below were formulated during the conduct of this study:

- Continue the development and testing of new sensing techniques which target specific SSME failure modes (fiber optic deflectionmeter, optical pyrometer, etc.)
- Design and develop an integrated condition monitoring system which includes both safety (real-time) and maintenance (off-line or ground-based) elements
- Pursue pattern recognition as a means for improving on-board engine condition monitoring
- Establish a condition monitoring data base to collect and integrate SSME historical and operational information
- Increase the computational capability of the SSME controller to expand engine monitoring
- Utilize the oxygen/hydrogen technology test bed engine to test and validate promising condition monitoring improvements.

TABLE OF CONTENTS

| | <u>Page</u> |
|--|-------------|
| INTRODUCTION | 1 |
| SSME FAILURE DATA REVIEW | 5 |
| Failure Modes Analysis | 5 |
| Data Collection | 5 |
| UCR Review | 6 |
| SSME Accident/Incident Reports Review | 13 |
| Failure Modes and Effects Analysis Report Review | 14 |
| Test Firing Cutoff UCRs Review | 16 |
| Failure Mode Ranking | 18 |
| Measurement Parameter Analysis | 19 |
| Conclusions | 27 |
| Recommendations | 28 |
| Partially Developed and Tested | 29 |
| Devices with Major Development Efforts Needed | 30 |
| DIAGNOSTICS SURVEY | 33 |
| Survey Approach and Methodology | 33 |
| Approach | 33 |
| Methodology | 34 |
| Diagnostics Background | 35 |
| Definitions | 35 |
| State Identification Process Hierarchy | 38 |
| Information Acquisition | 38 |
| Specifications | 38 |
| History | 39 |
| Sensors | 39 |
| Inspection | 39 |
| Information Reduction | 39 |
| State Identification | 40 |
| Summary and Conclusions | 41 |
| SSME Diagnostic and Maintenance System Overview | 42 |
| Information Gathering | 44 |
| Information Reduction | 45 |
| Diagnostic Decisions | 45 |
| Summary | 46 |

TABLE OF CONTENTS
Continued

| | <u>Page</u> |
|---|-------------|
| Survey Findings | 46 |
| Liquid-Fueled Rocket Engines | 46 |
| Data Acquisition | 47 |
| Signal Processing | 47 |
| Diagnostic Techniques | 47 |
| Highlights | 48 |
| Aircraft | 51 |
| Data Acquisition | 52 |
| Signal Processing | 52 |
| Diagnostic Techniques | 53 |
| Highlights | 54 |
| Non-Aerospace Industries | 58 |
| Data Acquisition | 58 |
| Signal Processing | 60 |
| Diagnostic Techniques | 60 |
| Recommendations | 62 |
| Data Acquisition | 62 |
| Signal Processing | 64 |
| Diagnostic Techniques | 65 |
| SSME DIAGNOSTIC EVALUATION | 67 |
| Issues and Approach | 67 |
| Failure Information Propagation Model | 68 |
| FIPM Example | 69 |
| High-Pressure Oxidizer Turbopump FIPM | 74 |
| Current FIPM Methodology | 78 |
| FIPM Definitions | 78 |
| FIPM Drawing | 79 |
| FIPM Data Base | 81 |
| Space Shuttle Main Engine FIPMs | 82 |
| FIPM DATA BASE | 85 |
| Data Base Structure | 85 |

TABLE OF CONTENTS
Continued

| | <u>Page</u> |
|--|-------------|
| Data Description | 89 |
| Domains SYSTEMS and SYSTEMS_FORM | 90 |
| Domains MODULES and MODULES_FORM | 93 |
| Domains FAILUREMODES and FAILUREMODES_FORM | 95 |
| Domains CONNECTIONS and CONNECTIONS_FORM | 97 |
| Domains PROPAGATIONS_A150 through PROPAGATIONS_Z910 and PROPAGATIONS_FORM | 99 |
| Domains REFERENCES and REFERENCES_FORM | 103 |
| FIPM DATA BASE SOFTWARE | 107 |
| Digital Command Language Procedures | 107 |
| Datatrieve Command Files, Procedures, and Tables | 115 |
| Terminal Data Management System Forms | 121 |
| FIPM DATA BASE TRANSFER | 123 |
| HIGH-PRESSURE OXIDIZER TURBOPUMP FIPM | 129 |
| Definition of High-Pressure Oxidizer Turbopump | 129 |
| High-Pressure Oxidizer Turbopump FIPM Drawing | 130 |
| High-Pressure Oxidizer Turbopump FIPM Data | 130 |
| Systems Data File | 131 |
| Modules Data File | 134 |
| Failure Modes Data File | 135 |
| Connections Data File | 137 |
| Failure Information Propagations Data File | 138 |
| References Data File | 140 |
| SSME FIPM DRAWINGS | 143 |
| HPOTP DIAGNOSTIC ASSESSMENT | 147 |
| Present Instrumentation | 147 |
| 1. LPOTP Discharge Pressure (HPOTP Pump Inlet) B400 0350 LQ 02 F B800 9910 PRESSURE | 153 |
| 2. HPOTP Discharge Pressure B400 0380 LQ 02 F B400 0390 PRESSURE | 153 |
| 3. Preburner Pump Discharge Pressure B400 0620 LQ 02 F B400 0630 PRESSURE | 153 |
| 4. Preburner Pump Discharge Temperature B400 0620 LQ 02 F B400 0630 TEMPERATURE | 153 |
| 5. HPOTP Turbine Discharge Temperature A150 9930 GA HG F B400 0080 TEMPERATURE | 154 |

TABLE OF CONTENTS

Continued

| | <u>Page</u> |
|---|-------------|
| 6. HPOTP Secondary Turbine Seal Drain Pressure B400 0170 GA HG T B400 0180 PRESSURE | 154 |
| 7. HPOTP Intermediate Seal Helium Purge Pressure B400 0260 GA HE F C200 9910 PRESSURE | 154 |
| 8. HPOTP Radial Accelerometers B400 0570 ME CP F B400 0600 VIBRATION | 154 |
| Test Point Analysis for Possible Future Instrumentation | 155 |
| 1. Bearing Fault Detection B400 0520 ME -- F B400 0530 VIBRATION B400 0550 ME -- F B400 0290 VIBRATION B400 0770 ME -- F B400 0790 VIBRATION | 166 |
| 2. Turbine Blade Fracture Detection B400 0050 ME -- F B400 0140 THERMAL B400 0070 ME -- F B400 0150 THERMAL | 166 |
| 3. Shaft Speed Sensor (RPM) B400 0410 ME -- F B400 0660 RPM, VIBRATION | 167 |
| 4. HPOTP Pump Outlet Flow - Ultrasonic Flowmeter B400 0380 LQ 02 F B400 0390 FLOW | 167 |
| HPOTP ACCELEROMETER DATA REVIEW | 169 |
| ON-BOARD CONDITION MONITORING | 177 |
| SSME Controller | 177 |
| Orbiter Telemetry and Recording Systems | 179 |
| Implications of SSME Monitoring Changes | 180 |
| SSME CONDITION MONITORING DEVELOPMENT | 183 |
| MAIN ENGINE COST/OPERATIONS MODEL | 187 |
| Cost Spread Functions for Budget Planning Exercise | 187 |
| Expanded Cost Displays | 187 |
| Revised Overhaul/Maintenance Procedures | 187 |
| Assessment of a Stochastic Model | 188 |
| Assessment of Graphics Requirements | 188 |
| On-Going Support/Minor Modifications | 188 |
| Documentation | 188 |
| REFERENCES | 189 |

TABLE OF CONTENTS
Continued

| | <u>Page</u> |
|---|-------------------|
| APPENDIX A -- FIPM DEVELOPMENT TOOLS | A-1 |
| APPENDIX B -- SSME FIPM DRAWINGS | (Separate Volume) |
| APPENDIX C -- EXCERPT FROM "HIGH-PRESSURE OXYGEN TURBOPUMP BEARING CAGE STABILITY ANALYSIS" REPORT TO NASA MSFC BY BATTELLE COLUMBUS DIVISION | C-1 |
| APPENDIX D -- STBE AND STME DIAGNOSTIC REQUIREMENTS DOCUMENT | D-1 |
| APPENDIX E -- MAIN ENGINE COST/OPERATIONS MODEL LOGIC DIAGRAMS . . . | E-1 |

LIST OF TABLES

| | <u>Page</u> |
|--|-------------|
| TABLE 1. FAILURE MODE RANKING RESULTS FOR RANK 5 OR ABOVE | 20 |
| TABLE 2. BREAK-DOWN OF THE DIAGNOSTIC HIERARCHY | 43 |
| TABLE 3. SUMMARY OF DIAGNOSTICS RECOMMENDATIONS | 63 |
| TABLE 4. FIPM RECORDS, DOMAINS, AND DATA FILES | 88 |
| TABLE 5. SUMMARY OF FIPM RECORD SYSTEMS_REC | 91 |
| TABLE 6. KEY FIELDS FOR DOMAINS SYSTEMS AND SYSTEMS_FORM | 93 |
| TABLE 7. SUMMARY OF FIPM RECORD MODULES_REC | 94 |
| TABLE 8. KEY FIELDS FOR DOMAINS MODULES AND MODULES_FORM | 95 |
| TABLE 9. SUMMARY OF FIPM RECORD FAILUREMODES_REC | 96 |
| TABLE 10. KEY FIELDS FOR DOMAINS FAILUREMODES AND FAILUREMODES_FORM | 97 |
| TABLE 11. SUMMARY OF FIPM RECORD CONNECTIONS_REC | 98 |
| TABLE 12. KEY FIELDS FOR DOMAINS CONNECTIONS AND CONNECTIONS_FORM | 99 |
| TABLE 13. SUMMARY OF FIPM RECORD PROPAGATIONS_REC | 100 |
| TABLE 14. KEY FIELDS FOR DOMAINS PROPAGATIONS_A150 THROUGH PROPAGATIONS_Z910 AND PROPAGATIONS_FORM | 102 |
| TABLE 15. SUMMARY OF FIPM RECORD REFERENCES_REC | 104 |
| TABLE 16. KEY FIELDS FOR DOMAINS REFERENCES AND REFERENCES_FORM | 105 |
| TABLE 17. PRESENT HPOTP INSTRUMENTATION | 148 |
| TABLE 18. FAILURE INFORMATION FOR CURRENT INSTRUMENTATION | 149 |
| TABLE 19. FAILURE INFORMATION FOR POSSIBLE FUTURE INSTRUMENTATION | 156 |

LIST OF FIGURES

| | <u>Page</u> |
|---|-------------|
| FIGURE 1. SAMPLE OF FIRST UCR REVIEW LISTING BY COMPONENT | 7 |
| FIGURE 2. SAMPLE OF FIRST UCR REVIEW FAILURE MODE TABLES | 7 |
| FIGURE 3. SAMPLE OF SECOND-CUT UCR TABLES | 8 |
| FIGURE 4. NUMBER OF UCRs BY FAILURE TYPE | 10 |
| FIGURE 5. NUMBER OF UCRs BY COMPONENT | 10 |
| FIGURE 6. FAULT TREE DIAGRAM FOR HOT-GAS MANIFOLD | 15 |
| FIGURE 7. EXAMPLE OF TEST FIRING CUTOFF UCR REVIEW TABLE | 17 |
| FIGURE 8. EXAMPLE OF MEASUREMENT PARAMETER TABLES | 26 |
| FIGURE 9. STRATEGY FOR STATE-OF-THE-ART SURVEY OF MACHINE DIAGNOSTICS | 34 |
| FIGURE 10. PARTITIONING OF SYSTEM STATES INTO OPERATIONAL AND ERRONEOUS STATES Notice the Overlap | 36 |
| FIGURE 11. THE HIERARCHY OF PROCESS REQUIRED FOR STATE IDENTIFICATION | 38 |
| FIGURE 12. MACHINE CONTROL VERSUS MACHINE DIAGNOSTICS NOTE THE OPPORTUNITY FOR SHARING RESOURCES | 42 |
| FIGURE 13. OVERALL SSME DIAGNOSTICS AND MAINTENANCE PICTURE | 44 |
| FIGURE 14. MODULES COMPRISING EXHAUST FAN FIPM | 71 |
| FIGURE 15. CONNECTIONS BETWEEN EXHAUST FAN MODULES | 71 |
| FIGURE 16. ADDITION OF FAILURE MODES TO EXHAUST FAN FIPM | 72 |
| FIGURE 17. FAILURE INFORMATION ASSOCIATED WITH EXHAUST FAN CONNECTIONS | 72 |
| FIGURE 18. FAILURE INFORMATION GROUPED BY SIGNAL TYPE FOR THE EXHAUST FAN FIPM | 73 |
| FIGURE 19. EXCERPT FROM INITIAL HPOTP FIPM | 75 |
| FIGURE 20. KEY FOR INITIAL HPOTP FIPM | 75 |
| FIGURE 21. FAILURE INFORMATION MATRIX FOR INITIAL HPOTP FIPM | 76 |
| FIGURE 22. KEY FOR CURRENT FIPM DRAWINGS | 80 |
| FIGURE 23. SAMPLE MODULE FROM AN FIPM DRAWING | 80 |
| FIGURE 24. SAMPLE CONNECTION FROM AN FIPM DRAWING | 81 |
| FIGURE 25. DATATRIEVE DEFINE DOMAIN COMMAND | 86 |
| FIGURE 26. DATATRIEVE DEFINE RECORD COMMAND | 86 |
| FIGURE 27. DATATRIEVE DEFINE FILE COMMAND | 87 |
| FIGURE 28. DOMAIN DEFINITION COMMANDS FOR PROPAGATIONS_A150 | 102 |
| FIGURE 29. FILE DEFINITION COMMANDS FOR PROPAGATIONS_A150 | 103 |
| FIGURE 30. MENU FOR CONTROLLED ACCESS TO FIPM DATA BASE | 109 |
| FIGURE 31. TOP-LEVEL FIPM SOFTWARE FLOWS | 109 |
| FIGURE 32. MENU FOR STORING FIPM DATA BASE RECORDS | 111 |
| FIGURE 33. PROGRAM FLOW FOR STORING FIPM DATA | 111 |
| FIGURE 34. MENU FOR MODIFYING FIPM DATA BASE RECORDS | 112 |
| FIGURE 35. PROGRAM FLOW FOR MODIFYING FIPM DATA | 112 |
| FIGURE 36. MENU FOR LISTING FIPM DATA BASE RECORDS | 113 |
| FIGURE 37. PROGRAM FLOW FOR LISTING FIPM DATA | 114 |
| FIGURE 38. SAMPLE DATATRIEVE TABLE | 115 |
| FIGURE 39. DATATRIEVE COMMAND FILES, PROCEDURES AND TABLES USED TO STORE FIPM DATA | 117 |

LIST OF FIGURES
Continued

| | | <u>Page</u> |
|------------|---|-------------|
| FIGURE 40. | DATATRIEVE COMMAND FILES, PROCEDURES AND TABLES USED TO MODIFY FIPM DATA | 118 |
| FIGURE 41. | DATATRIEVE COMMAND FILES AND PROCEDURES USED TO LIST FIPM DATA | 120 |
| FIGURE 42. | MISCELLANEOUS DATATRIEVE PROCEDURES AND TABLES USED FOR FIPM | 120 |
| FIGURE 43. | FIPM REQUEST LIBRARY DEFINITION | 121 |
| FIGURE 44. | VAX/VMS FILES USED TO TRANSFER FIPM DATA BASE | 123 |
| FIGURE 45. | FIPM DIRECTORY STRUCTURE | 125 |
| FIGURE 46. | DIRECTORY DEV\$206:[BCDSSME2] | 126 |
| FIGURE 47. | DIRECTORY DEV\$206:[BCDSSME2.DATA] | 126 |
| FIGURE 48. | DIRECTORY DEV\$206:[BCDSSME2.DTR] | 127 |
| FIGURE 49. | DIRECTORY DEV\$206:[BCDSSME2.FIPM] | 127 |
| FIGURE 50. | DIRECTORY DEV\$206:[BCDSSME2.FORMS] | 127 |
| FIGURE 51. | RELATIONSHIPS BETWEEN DATA RECORDS IN FIPM DOMAINS | 132 |
| FIGURE 52. | SAMPLE RECORD FROM DOMAIN SYSTEMS | 133 |
| FIGURE 53. | SAMPLE RECORD FROM DOMAIN MODULES | 134 |
| FIGURE 54. | SAMPLE RECORD FROM DOMAIN FAILUREMODES | 135 |
| FIGURE 55. | ELEMENTS REPRESENTED BY FMCODE | 136 |
| FIGURE 56. | SAMPLE RECORD FROM DOMAIN CONNECTIONS | 137 |
| FIGURE 57. | ELEMENTS CONTAINED IN CODE_NUMBER | 138 |
| FIGURE 58. | SAMPLE RECORD FROM DOMAIN PROPAGATIONS_B400 | 139 |
| FIGURE 59. | SAMPLE RECORD FROM DOMAIN REFERENCES | 141 |
| FIGURE 60. | IMPACT OF CAGE AND BALLS AT APPROXIMATELY 450 HZ. CALCULATED BY BASDAP FOR A MARGINALLY STABLE CASE (Reference 8) | 170 |
| FIGURE 61. | HIGH-FREQUENCY CAGE INSTABILITY WITH 2X FREQUENCY SUPERIMPOSED. CALCULATED BY BASDAP (Reference 8) | 170 |
| FIGURE 62. | TEST 7500283 HPOTP RADIAL ACCELEROMETER 135° FREQUENCY VERSUS ACCELERATION PLOT AT 265.2 SECONDS | 171 |
| FIGURE 63. | TEST 7500284 HPOTP PREBURNER PUMP RADIAL ACCELEROMETER 45° SPECTRAL MAPS SHOWING 1X AND 2X CAGE FREQUENCY PEAKS | 172 |
| FIGURE 64. | VIBRATION SPECTRAL DATA FOR THE BEARING SERVICE LIFE IN A POWER PLANT AXIAL-FLOW FAN. (REFERENCE 9) | 174 |
| FIGURE 65. | SSME CONTROLLER ORGANIZATION | 178 |

STUDIES AND ANALYSES OF THE SPACE SHUTTLE MAIN ENGINE

Contract Number NASw-3737

FINAL REPORT

INTRODUCTION

The National Aeronautics and Space Administration (NASA) has increasingly stressed condition monitoring and failure diagnostics as a major element of the Space Shuttle program. The overall importance of condition monitoring has been elevated by the reusability of key Space Shuttle hardware elements such as the Orbiter, Space Shuttle Main Engines (SSMEs), and Solid Rocket Boosters (SRBs). Valid condition and failure data is needed to verify the proper functioning of the Space Shuttle during its mission as well as to evaluate the maintenance required between flights. The principal NASA goals for monitoring and diagnostic systems are increased Space Shuttle reliability and safety coupled with reduced maintenance and turnaround costs. To accomplish these goals, NASA is exploring the entire spectrum of monitoring and diagnostic techniques. Research is being conducted in the areas of instrumentation, data acquisition, data analysis, automated decision making, and automated record keeping. These investigations are being carried out by several of the NASA field centers with the support of a number of contractors.

NASA is emphasizing the SSME as a key candidate for condition monitoring and diagnostics. The need for accurate SSME data is the direct result of the engine's vital role during Space Shuttle launch and ascent. The ability to monitor, diagnose, and control degradations or failures of an operating engine is important to both safety and mission success. It is also desirable to obtain an accurate assessment of the engine's overall condition following each launch or ground test. Decisions concerning an engine's suitability for a subsequent mission or test and the extent of any post-operation maintenance or repairs require detailed data on major engine components. However, the goal of accurately monitoring and diagnosing conditions in the SSME is complicated by a number of factors including: the general engine design which maximizes performance while minimizing size and weight; the severe thermal and acoustic environments during engine operation; the physical properties of the liquid oxygen and

liquid hydrogen propellants; and the extremely small time constants associated with major degradations and failures.

This study was initiated by the NASA Headquarters, Office of Shuttle Operations, Propulsion Division in July 1983 to evaluate various means for improving the condition monitoring (diagnostic) system for the SSME. The effort was to include both flight and ground test operations. The primary objective of the study was to maximize the information yield which could be obtained from the current engine sensors. The secondary objective was to identify additional sensors or diagnostic capabilities which would significantly improve the available engine data. The study also included continued development and support of the Main Engine Cost/Operations (MECO) model.

The statement of work for this study included the following five tasks:

- SSME failure data review
- Diagnostic survey
- SSME diagnostic evaluation
- Diagnostic implementation plan
- MECO refinement and support.

The SSME failure data review involved the collection, review, and assessment of available information on the engine failure modes and failure history. The results of this task would be used to determine engine monitoring priorities. The diagnostic survey was to collect and review information on a broad spectrum of sensors and techniques used in aerospace and other heavy industrial applications. The output would be used to identify promising candidates for application to the SSME. The SSME diagnostic evaluation was to combine the results of the failure data review and the diagnostic survey to determine ways to improve the SSME condition monitoring system. The diagnostic implementation plan was to suggest a programmatic and budgetary framework to accomplish the recommendations of this study. The MECO refinement and support task included continued user support for NASA Headquarters and program modifications to provide new capabilities.

NASA Headquarters decided in late 1984 to continue the effort begun under this contract by expanding the scope of the activities included in the SSME diagnostic evaluation. The task to develop a diagnostic implementation plan was deferred until the completion of the analysis activities. A contract modification added the following five tasks to the statement of work:

- Continuation of SSME diagnostic evaluation
 - Failure information propagation model (FIPM) data base development
 - SSME FIPMs
- Assessment of candidate diagnostics
- Analysis of existing engine data
- On-board diagnostic implications
- Diagnostic implementation plan (deferred from previous phase)
- MECO analysis and programming support.

The task to continue the SSME diagnostic evaluation was focused on developing FIPMs for the major SSME components. As a precursor to this activity, it was necessary to develop a computerized data base system to store and manipulate the associated information. The assessment of candidate diagnostics was to use the FIPMs to analyze the failure information available at current sensor locations. This assessment was also to examine potential monitoring system improvements on the basis of the new failure information obtained. The analysis of existing engine data was directed at comparing the output of the FIPM against recorded information from engine sensors. The on-board diagnostic implications task was to identify the potential controller and telemetry impacts which might result from suggested changes in the SSME condition monitoring system. The implementation plan was to provide a suggested schedule and funding level required to develop any candidate improvements resulting from this study. The final task was to provide continued support of the MECO model to NASA Headquarters.

This report summarizes all of the work performed under NASA Contract Number NASw-3737. The major sections of this report correspond

to the study tasks mentioned in the preceding paragraphs. It should be noted that this contract was transferred from NASA Headquarters to the NASA Marshall Space Flight Center, Science and Engineering Directorate, Propulsion Laboratory in March 1986. Most of the work during the second phase of this study was accomplished under the direction of the Marshall Space Flight Center (MSFC) technical staff.

SSME FAILURE DATA REVIEW

The first task of the SSME study was to develop an understanding of the engine operating characteristics and failure modes. The task included collection and reduction of data on SSME failure modes, categorization of the failure modes, ranking of the failure modes, identification and evaluation of measurable parameters for each failure mode, and identification of parameters for possible trending information. This information is necessary to evaluate the effectiveness of diagnostic monitoring systems.

Failure Modes Analysis

Data Collection

Most of the data necessary for the failure modes analysis was supplied by the Rocketdyne Division, Rockwell International Corporation, Canoga Park, CA. The main source of information was the Unsatisfactory Condition Reports (UCRs). Since there were many UCRs written and Rocketdyne's previous study had included UCR information through 1979, it was decided in the present study to review all UCRs in a three-line format from January 1980 through November 1983. After the preliminary data reduction had taken place, selected full-page UCRs were collected for review. Other supplemental information received from Rocketdyne included the Failure Modes and Effects Analysis (FMEA) Report and Accident/Incident Reports for 1980 through 1983.

To provide Battelle personnel with additional information, engine data from a recent test firing and a Shuttle flight were obtained from NASA Marshall Space Flight Center (MSFC) along with general information on the SSME program. A diagnostics overview presentation was given by NASA Lewis Research Center (LeRC) personnel along with other general information needed to educate the Battelle researchers about various aspects of the SSME program. Information was also obtained from Rocketdyne personnel at NASA Kennedy Space Center (KSC) with regard to maintenance procedure and history.

UCR Review

To identify the SSME failure modes and their relative importance, all three-line UCRs written from January 1980 through November 1983 were reviewed and categorized. Approximately 3000 UCRs were used in the review process. Each UCR had a criticality factor associated with it which ranged from one to three, one being the most dangerous. The only UCRs that were eliminated on the basis of their low criticality factor were those that had criticality N, or no criticality factor. These were very minor problems for which a UCR should not necessarily have been written. Some UCRs of criticality three were eliminated because the problem described could not possibly cause any failures. Examples of this type include UCRs written on normal discolorations of the main combustion chamber or small contaminants on the nozzle that could not affect engine performance. Approximately 2900 UCRs were included in the first-cut review.

The complete listing of the UCRs and their criticalities by component is contained in Reference 1, Appendix A. A sample of the UCR listing is shown in Figure 1. The high-pressure fuel turbopump had the most UCRs followed by the high-pressure oxidizer turbopump and the nozzle, respectively. The high-pressure oxidizer turbopump had the most criticality one UCRs, followed by the main injector, heat exchanger, and high-pressure fuel turbopump, in that order.

A breakdown of the failure modes, cause, and recurrence control for each component is contained in Reference 1, Appendix B. A sample failure table mode is given in Figure 2. There were literally hundreds of failure modes identified, many having several causes. A large percentage of the problems were assembly or manufacturing problems. Most listed design, assembly, or manufacturing changes to correct the problems.

| Component | Description | Total No. of UCR'S | CRITICALITY | | | |
|-----------|----------------------------------|--------------------------|-------------|----|-----|----|
| | | | 1 | 2 | 3 | N* |
| A100 | Hot Gas Manifold | 80 | 2 | | 77 | 1 |
| A150 | Heat Exchanger | 18 | 4 | | 12 | 2 |
| A200 | Main Injector | 175 | 5 | 3 | 162 | 5 |
| A330 | Main Combustion Chamber | 105 | 1 | 3 | 98 | 3 |
| A340 | Nozzle | 296 | | 2 | 285 | 9 |
| A600 | Fuel Preburner | 171 | | 2 | 165 | 4 |
| A700 | Oxidizer Preburner | 13 | | | 13 | |
| B200 | High Pressure Fuel Turbopump | 457 | 3 | 11 | 429 | 14 |
| B400 | High Pressure Oxidizer Turbopump | 331 | 7 | 11 | 302 | 11 |

FIGURE 1. SAMPLE OF FIRST UCR REVIEW LISTING BY COMPONENT

| Fail. ID | Failure Mode - Failure Cause - Recurrence Control | Total No. | Criticality | | | |
|-------------|--|--------------|-------------|---|---|---|
| | | | 1 | 2 | 3 | N |
| 1 | Leak | | | | | |
| | (a) Pin Plug Leak--Inadequate Seal--Add Leak Test | 1 | | | 1 | |
| | (b) Wireway Leak--Epoxy Did Not Adhere-- Process Change | 3 | | | 3 | |
| | (c) Internal Leak--Tolerance Stackup-- Detectable in Test | 2 | | | 2 | |
| | (d) Hyd Oil Leak--Excessive Proof Test Cycling--None | 2 | | | 2 | |
| | (e) Static Seal Leak--Burr Induced Scratch-- New Inspection | 1 | | | 1 | |
| | (f) Vent Port Leak--Defective O-Ring--Open | 2 | | | 2 | |
| | (g) Wireway Leak--Inadequate Epoxy Coverage-- Spec. Change | 2 | | | 2 | |
| 2 | Hydraulic Lockup Drift--Mfg. Error--Detectable-- None | 5 | | | 5 | |
| 3 | Slew Rate Error--Contamination--None | 2 | | | 2 | |

FIGURE 2. SAMPLE OF FIRST UCR REVIEW FAILURE MODE TABLES

The next step in data reduction was to chart the failure modes over time to see whether the recurrence control procedures had remedied the problems. Also, the failure mode listings were revised to combine like failure modes and to eliminate those that were minor, had occurred only once or twice, and where the corrective action showed that there were no recurrences. The results of this review are contained in Reference 1, Appendix C. A sample second-cut UCR table is shown in Figure 3. After this step, the number of UCRs remaining was approximately 1900 from the original 3000 reviewed including 260 failure modes.

| Comp. J-600 Failure | Time Period (Months) | | | | | | | | Criticality | | | Description - Cause Resolution |
|---------------------------|----------------------|------|------|------|------|------|------|------|-------------|----|----|--|
| | 1980 | | 1981 | | 1982 | | 1983 | | 1 | 2 | 3 | |
| | 1-6 | 7-12 | 1-6 | 7-12 | 1-6 | 7-12 | 1-6 | 7-12 | | | | |
| 1 | | | | | | | 2 | | -- | -- | 2 | Low insulation resistance-damage @ fabrication-none |
| 3 | | | | | 1 | | | | -- | -- | 1 | Broken wire-suspect thermal induced-thermal test revised |
| 4a | 1 | 2 | | | 1 | | | | -- | -- | 4 | Output failure-unknown-none |
| 4c | | | | 1 | | | | | -- | -- | 1 | Erratic output-suspect sensor nut variations-evaluation |
| 5 | | 2 | | | | | | | -- | 2 | -- | Open circuit, encapsulement cracks-assembly-assy. change |

FIGURE 3. SAMPLE OF SECOND-CUT UCR TABLES

The final step in the UCR data reduction was to collect the significant full-page UCRs and review the detailed information. At least one full-page UCR was requested from Rocketdyne for each failure mode identified. As a result of this step, several more failure modes were eliminated because they were minor problems of an aesthetic nature or were items which quality control and/or engine pretesting would eliminate. Some failure mode descriptions were modified using the more detailed information in the full-page UCRs. The full-page UCRs also provided more

information as to the severity of the failure mode for use in the ranking of the failure modes. At the conclusion of the full-page UCR review, some failure modes were found to be similar enough to be grouped together. With some of the failure modes being eliminated, there were 1440 of the original 3000 UCRs and approximately 190 failure modes.

Many of the failure modes in the UCR review were of an infrequent nature and were the result of assembly, procedure, or repair mistakes. Only a few of the failures were recurrent in nature and posed an important safety risk. (Among these were turbopump bearing wear, turbine blade cracking, nozzle leaks, injector erosion, and sensor system failures.)

The failure modes were then placed into fifteen categories and tabulated for each component. This categorization resulted in a matrix which is found in Reference 1, Appendix D. Figure 4 gives one dimension of the matrix, the number of UCRs versus failure type after the completed screening process. Cracking, usually caused by vibration or thermally induced fatigue, was shown to be the dominant failure type followed by various leakage problems. Most of the leakage UCRs were written on the nozzle coolant tubes which are mainly a time consuming maintenance item. The electrical problems mostly related to the sensors and their associated wiring. Contamination was a significant problem and was found on many of the components; it was usually caused by assembly errors and some contamination could precipitate many other failures depending upon the type of contaminant and location involved. Erosion was mainly a problem in the high temperature areas such as the injectors, turbines, and igniters. Wear was typically a problem for the high-pressure oxidizer turbopump bearings and this has been a continuing problem on the SSME. Torque, vibration, and excess travel problems are measurements made on the turbopumps to check for problems before they lead to catastrophic failure. The rest of the categories are not indicative of any particular component of the SSME.

Figure 5 shows the number of UCRs versus individual SSME components. The dominance of the two high-pressure turbopumps along with the disparity between the preburners are the most striking features in the graph. A detailed listing of the failure types and causes for each component is found in Reference 1, Appendix E.

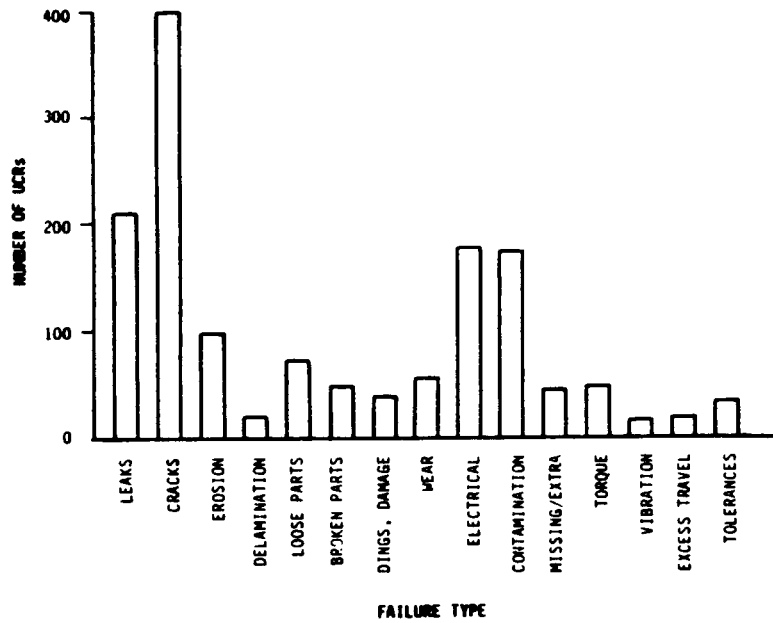

FIGURE 4. NUMBER OF UCRs BY FAILURE TYPE

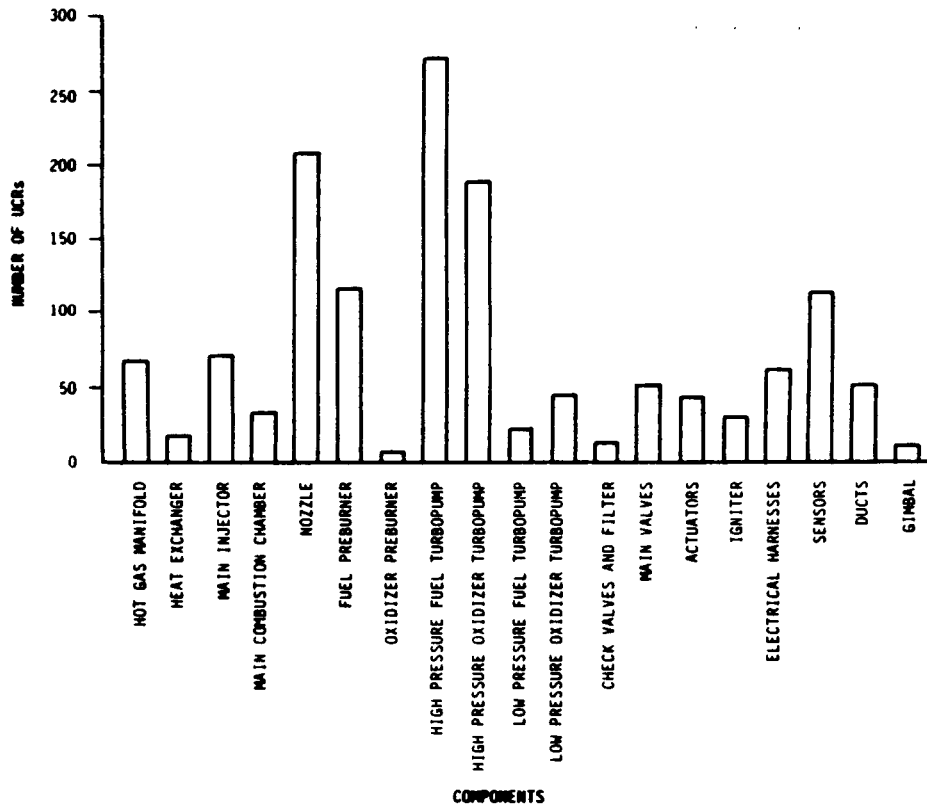

FIGURE 5. NUMBER OF UCRs BY COMPONENT

A brief description of the failure modes and general problems for most of the major components follows:

High-Pressure Fuel Turbopump (HPFTP) - The turbine area of the HPFTP is subjected to higher temperature and pressure than the other turbopumps in the SSME and consequently has more problems. Erosion and fatigue cracking were the subject of many UCRs for the turbine blades, turbine sheetmetal, and preburner to turbine joint area. The pump inlet and diffuser had a few failures along with some minor bearing problems. Seal leakage and rubbing has been more of a problem than in the high-pressure oxidizer turbopump. Vibration due to cavitation and possible near resonance vibration conditions have been the subject of several UCRs.

High-Pressure Oxidizer Turbopump (HPOTP) - Bearing problems have been a major source of UCRs for the HPOTP including severe vibration levels during testing as well as bearing ball and race wear. Bearing cage delamination has also occurred several times. Turbine blade cracking and erosion has been a lesser problem on this turbopump than for the fuel turbopump. Contamination and erosion of the turbine area is also a concern. Turbine area rubbing and minor sheetmetal cracking have also been reported.

Nozzle - Unlike the rotating machinery, the nozzle has only a few problems. Cracking and leakage in the small nozzle coolant tubes that line the inside of the nozzle are the most common source of UCRs. Nozzle coolant tube leakage is caused by vibration fatigue, thermal fatigue, and brazing anomalies in assembly or repair. While these leaks are usually a nuisance item, the nozzle has been the source of at least one catastrophic failure. A steerhorn rupture caused by the use of incorrect weld wire during fabrication destroyed an engine on the National Space Technology Laboratories (NSTL) test stand.

Sensors and Electrical Harnesses - Sensor or sensor output failures were a frequent problem and are to be expected in view

of the environmental extremes associated with the SSME. Typically, temperature and pressure sensors had the highest failure rate. Sensor reliability is an extremely important factor in designing an on-board diagnostic system. To date, the only specific action taken with respect to a post-flight data review is to replace faulty sensors or sensor cabling.

Fuel Preburner (FPB), Oxidizer Preburner (OPB), and Main Injector - All three of these components have similar problems even though the fuel preburner dominates the number of UCRs. This is probably due to the higher temperature and pressure in the FPB. Erosion and cracking of the LOX posts and injector faceplates are the most frequent subject of the UCRs on the injectors. Vibration, temperature, and nonconcentricity of the LOX posts are the primary causes of injector failures.

Hot-Gas Manifold (HGM) - Cracking and rupture of ducting was the primary failure mode and this is caused by vibration loading or assembly error. Leakage at the joints along with loose fasteners which could cause leakage was also a problem.

Main Combustion Chamber (MCC) - Most of the UCRs were written for erosion or cracking on the hot-gas wall of the MCC. Low-pressure fuel turbine drive manifold leaks were the only major failure occurrences for this component.

Heat Exchanger (HE) - There were few UCRs written for the heat exchanger, probably because of the extreme precautions taken during assembly. Small leaks of oxygen from the HE would be catastrophic, so even minor tolerance and clearance discrepancies were reported in UCRs.

Low-Pressure Turbopumps (LPFTP) and (LPOTP) - These had problems similar to those for the high-pressure turbopumps, but they were minor in nature and much less frequent.

Valves and Actuators - Leaks were the common thread throughout the UCRs on these components. Internal leakage and ball seal leakage occurred in various valves and actuators. Also, valves

did not function properly due to contaminants or a noisy or erratic position transducer signal.

Igniter - The igniter UCRs usually dealt with either the electrical connection or tip erosion failures.

Fuel Line, Oxidizer Line, and Drain Line Ducts - Joint problems and joint leakage were the focus of most of these UCRs. Weld and seal cracks also occurred.

Gimbal - Wear of the gimbal and cracks in the bushing were the two failure modes which caused UCRs to be written for the gimbal.

SSME Accident/Incident Reports Review

Major failures of the SSME or its components are subjected to a rigorous review with the results summarized in Accident/Incident Reports. The eight reports written between January 1980 and December 1983 were reviewed for failure mode information and the value of present instrumentation for failure detection. Summaries of the individual reports are contained in Reference 1, Appendix F.

During this four-year period, there were no duplications of any of these major failures. This indicates the complexity of the SSME and the degree of randomness involved in the failures. The nonrepetitiveness of the failures is also influenced by the detailed analysis of the incidents and the corrective actions taken to prevent recurrence.

Certain reports showed that human error in the SSME fabrication and assembly cannot totally be eliminated. The use of the wrong weld wire on the steerhorn portion of the nozzle caused a catastrophic failure and a welding mistake on the heat exchanger coil could have destroyed an engine or worse had it gone undetected. The UCR data reviewed has shown that human error in fabrication, assembly, and repair has been a constant source of problems.

Most of the catastrophic failures occurred on test stands after the instrumentation had indicated an unsafe condition and shutdown procedures had been started. In these cases, the time between detection

of the measured failure condition and the consequent engine destruction was much shorter than the time to safely shut down the engine. To correctly and safely shut down the SSME, deteriorating conditions must be detected earlier than is presently being done. Because of the random causes of these major failures, the diagnostic system design should include as many of the engine parameters as is economically and technically possible.

Failure Modes and Effects Analysis Report Review

The Failure Modes and Effects Analysis (FMEA) Report prepared by Rocketdyne was reviewed to evaluate failure modes to help in ranking them. Although it was some help for major failure types and valve procedure problems, the FMEA Report did not contain a sufficiently thorough analysis of the failure modes and their propagation paths.

Fault tree diagrams are very helpful in charting failure modes and their effects on the engine. Figure 6 shows an example of such a diagram for the hot-gas manifold. Reference 1, Appendix G contains fault tree diagrams for each of the major components. The diagrams provided in this report are not at a detailed piece-part level, but at the level shown, they can help with two major tasks. They show the cause and effect of particular failure modes in a simple graphical fashion which determines their relevant importance and provides a means for diagnosis. Another important aspect of the fault tree diagram is that they allow the representation of failure propagation times for each step in the failure process, and this is important in structuring a diagnostic system, as indicated below.

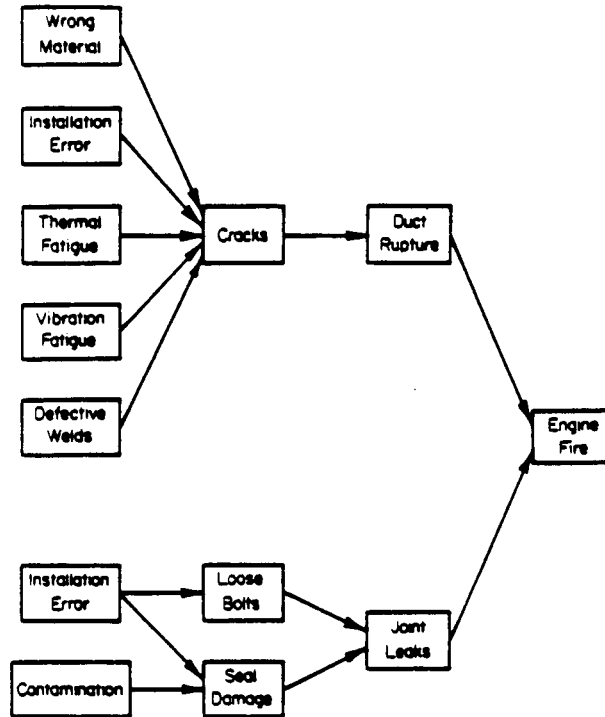

FIGURE 6. FAULT TREE DIAGRAM FOR HOT-GAS MANIFOLD

Because the time between the duct rupturing and engine fire (Figure 6) could be practically instantaneous, detection of such ruptures is too late for shutdown and would not be an effective diagnostic measurement. The diagram shows that cracking precedes rupturing of the duct and may be detectable for many seconds before rupture occurs. If the failure could be detected at this level, the engine could be safely shut down and repaired. To detect all the causes of cracking, however, might take a prohibitive amount of time and be very costly.

In many cases, the most desired failure mode to detect may be realistically undetectable because of the advanced level of technology needed or because the environment within the engine would preclude measurement. In these cases, ground inspection techniques for the failure modes may be necessary. The fault tree diagram can be used to check the

completeness of the diagnostic system. If the system checks for cracking of the ducts, but fails to detect loose bolts, the diagram in Figure 6 indicates that an engine fire would still be a possibility. Thus, if a particular failure mode propagates very quickly and there is presently no method for detection, then it may be cost effective to develop an appropriate sensor.

To conclude, the FMEA report should be greatly expanded with inputs from the Rocketdyne design groups for each particular component by assessing the thermal and vibration environment in conjunction with the design parameters.

Test Firing Cutoff UCRs Review

The UCRs that resulted from test firing cutoffs (shutdowns) from early 1975 through late 1983 were reviewed to assist in determining the usefulness of the present sensors on the SSME for the design of a diagnostic system. Even though the sensors produced a significant number of improper cutoffs, as shown in the tables in Reference 1, Appendix H, there were also many shutdowns that were due to valid measurements. These shutdowns were usually due to simple signal-level-activated commands. However, several catastrophic failures occurred after some safety limits ("red lines") had been exceeded but before shutdown could be completed.

Figure 7 is an example of the tables of the reduced UCR data. The data are organized by the measurement that caused shutdown. The year of occurrence, the number of improper cutoffs, the criticality of the UCR, the place they occurred, and the determined cause and action taken are included in the table. If there was a valid reason for the measurement to have exceeded the appropriate "red line" level, it was not an improper cutoff. Of over 255 test firing cutoffs, 41 (16 percent) were the fault of the test facility or the controller; 130 (51 percent) of the UCRs involved cutoffs for valid reasons.

This does not, however, mean that a similar event would result in an engine shutdown during flight. The importance of engine power output to the safety of a flight is such that many undesirable conditions would be accepted, but the basis for an overall diagnostic system may well reside with these previously used basic sensors. Other activities, moreover, will be required to adapt these sensors. For example, signal processing techniques, such as frequency domain and trend analysis, may be utilized to locate specific failures. Outputs from several sensors may indicate a unique failure mode (pattern recognition). Downstream and upstream sensors can be used to validate sensor output to improve the reliability of any diagnosis. Some of these techniques can be used for prognostic monitoring, and with the inclusion of a ground-based data acquisition and maintenance computer system, the results can be in the maintenance personnel's hands before the Shuttle returns. Such an "expert system" would be too slow for on-board diagnosis using today's computer technology, but may become a viable on-board tool in the future.

For the most part, fast-propagating and high-criticality failure modes are key targets for any on-board diagnostic or shutdown decisions. The present sensors should be helpful, but optimized placement of these sensors may be necessary. Also, knowledge of the background signal levels and expected signal levels of the failure modes is important.

Failure Mode Ranking

To assess the importance of each failure mode to the design of a diagnostic monitoring system, a procedure for ranking the failure modes was developed. Three factors were given equal weighting for the ranking:

Cost Factor - estimated cost per year of the failure after subtracting the cost that diagnostics could not eliminate

Risk Factor - based on the criticality factor

Time Factor - estimated time for failure mode to propagate to a catastrophic failure.

A detailed explanation of the ranking procedure can be found in Reference 1, Appendix I along with the tabulated results. The failure modes are

ranked in categories of importance from 1 to 10, with 1 being the most critical and 10 the least.

Failure modes in Categories 1 through 5, listed in Table 1, are most important and must be considered in the design of an on-board diagnostic system. In Categories 6 through 10, some failure modes may still be economically included in an on-board system although they are not ranked very high. Their inclusion should depend on the additional cost involved to detect each failure mode. Due to economic and technical considerations, some highly-rated failure modes may be impossible to include in an on-board system in the near future, but they are important areas for research and development of either in-flight or ground-based detection methods.

Measurement Parameter Analysis

Once the importance of the failure modes to the design of a diagnostic system has been evaluated, the measurements that can detect each failure mode must be identified and evaluated. To evaluate the measurement parameters, certain factors must be assessed such as signal level, background noise, existence of commercially available transducers, feasibility of developing special transducers, and the information necessary to uniquely identify the failure modes.

Signal level and background noise can only be roughly evaluated by experience and engineering judgment. An important step in evaluating signal levels quantitatively is to review the real-time data recordings of test stand and flight engine firings. Analyzing the real-time analog data should provide enough information to assess signal and noise levels, and may also indicate signal processing enhancements that would discriminate particular failure occurrences.

TABLE 1. FAILURE MODE RANKING RESULTS FOR RANK 5 OR ABOVE

| RANK | COMPONENT | FAILURE MODE |
|------|---|--|
| 1 | HPOTP Heat Exchanger | Vibration - bearing loading Cracks, leak in coil |
| 2 | Hot-Gas Manifold Hot-Gas Manifold Main Injector HPOTP | Cracks, rupture in duct Leak in MCC ignition joint ASI supply line cracks Bearing ball and race wear |
| 3 | MCC HPFTP | Turbine drive manifold leak G-5 joint erosion |
| 4 | Sensors Nozzle Fuel Preburner HPFTP HPFTP HPFTP Ball Valves Poppet Valves Sensors | Temp. and press. output failures Steerhorn rupture Faceplate erosion Diffuser failure Inlet failure Missing shield nuts Ball seal leak and ball melting Cracked poppet Temperature sensor debonding |
| 5 | Main Injector Fuel Preburner Fuel Preburner Fuel Preburner HPFTP HPFTP HPFTP HPFTP HPOTP HPOTP Check Valves Igniter Electrical Harnesses Electrical Harnesses Electrical Harnesses Duct Seals HPOTP | Heat shield retainer cracks Baffle and LOX post erosion Baffle, molyshield, and liner cracks Missing/extra support pins Turbine blade and platform erosion Seal cracking Coolie cap nut cracking Broken turbine blades Turbine blade cracks Bearing cage delamination Check valve leaks Igniter tip erosion Birdcaged harness Loose, defective connector Debonded torque lock Seal damage Vibration level - cavitation |

With reference to Figure 4, the several hundred failure modes for the entire engine can be reduced to about fifteen failure types. In particular leaks and cracks are by far the most common failure type among all the failure modes. Each failure type has a unique signature, but since many failure modes have the same failure type, it may be difficult to identify a particular failure mode. A brief description of each failure type, the nature of the signal produced, and the possibility of identifying individual failure modes follows:

Leaks - Leakage of a liquid or gas from the system, or from one component to another within the system, can occur in several ways. It may be due to a crack in a structure, a bad seal, or possibly a malfunctioning valve. Presently, leaks are detected between flights by pressurizing the system with helium. The signals produced by leakage for possible in-flight detection are sound, vibration, optical, and possibly, in some cases, temperature or engine performance. In most cases, the sound and vibration signals will be low when compared to the background noise, probably even at ultrasonic frequencies (acoustic emission frequencies). An acoustic emission method for leak detection would moreover require many transducers to detect all the possible places that leaks can occur even if selected as a between-flight method of leak detection. Optical methods such as holographic leak detection are still in the developmental stages and also have resolution problems in detecting small leaks and are moreover only applicable where easy access is possible (e.g., for external leakage). In many cases, indirect measurements such as temperature, flow, or pressure may infer leakage. For example, leakage of hot gas into coolant passages could be detected by temperature measurements. Also if the leakage is severe enough, it will affect the downstream pressure and flow.

Cracks - Cracking of a structure is usually caused by mechanical or thermal loading which can eventually lead to failure of the structure with possible secondary effects such as fluid leakage. One present method of detecting cracking is by

measuring the acoustic signal in the structure's material caused by the energy released through the cracking phenomena. These signals are detected by acoustic emission transducers at a frequency dependent upon material properties. High background noise, however, may be a problem in the application of this technique to many parts of the SSME. Other detection methods include magnetic, electric potential, and mechanical impedance methods. When the cracking leads to other problems, detection of these failure modes may be easier. But, since these are secondary effects, catastrophic failure of a component may be imminent, and the ability to shut down the SSME with minimal damage at this point may be impossible. Nevertheless, predicting cracking by trending vibration and temperature data should be useful in monitoring structural fatigue life.

Erosion - Erosion of surfaces usually occurs in the hot-gas turbine sections of turbopumps and in injectors. In the case of injectors, local hot spots may indicate erosion. In the case of both turbine and injector erosion, the performance of the turbopump and downstream components will directly be affected and should give rise to indicative measurements. Temperature trending of these components may be the most useful measurement possible in flight. Detection of ablated particles or, more likely, surface wear is possible in the case of erosion. Isotope wear detection, presently being developed by Rocketdyne, is considered to have the best chance of success for erosion detection.

Wear - Wear is caused by surface friction on a component due to mechanical contact or flow impingement. Erosion is a special case of wear, but it has been considered in a separate category of its own. Wear was considered, in this study, to result from mechanical contact between components with relative motion. Wear in the SSME generally occurs in the rotating machinery, e.g. the turbopumps. Bearings are the most critical parts affected by wear, followed by seals. Rubbing usually causes vibration, and in many cases the nature of the vibration signal

can be used to identify which parts are involved. For example, seal rubbing may involve some RPM related vibration as well as indirect measurements such as reduced shaft RPM and torque. Wear is usually detected at high frequencies where the ambient noise is relatively low. More accurate measurements may be made by isotope wear detection (but not for pitting), magnetic wear detection, or ultrasonic doppler transducer. Magnetic wear detection measures the ball passage frequency. Ultrasonic doppler transducers can detect the shaft vibration, and should be more sensitive to bearing wear than vibration of the housing. Detection of worn particles or surface wear is also possible, as in the case of erosion. Isotope wear shows the most promise in this category. All these wear detection methods, moreover, are nonintrusive. Another possible wear measurement device, the fiberoptic deflectometer, however, would be intrusive.

Dings, Dents, and Damage - This is a general category that usually relates to debris impacting a part of the SSME. This can usually be detected by vibration sensors as a high-energy impulse signal.

Electrical - Electrical problems in this study relate to sensors, sensor cabling, and electrical connections. Many systems presently can self-check for continuity and other transducers can be used to verify the validity of a sensor's output (analytic redundancy), rather than using multiple sensor redundancy to increase sensor reliability.

Contamination - Contamination is a broad category of foreign deposits or objects present in a component. In most cases there is little or no effect, but problems such as reduced coolant flow through passages and impaired valve operation can occur. The effects of contamination can manifest themselves in different ways, but temperature, flow, and pressure measurements generally provide a good indication of a serious contamination problem.

Delamination and Broken Parts - These failure types are further extensions of cracking and several other failure types previously discussed. When a part fails structurally, the vibration signal will increase dramatically in most cases, but catastrophic failure of the engine may also be imminent.

Loose Parts - This category usually refers to connections involving bolts or other fasteners. The possibilities for detection include increased vibration levels, an optical method, and measurement of torque on the bolt.

Missing/Extra Parts - This failure type is usually a problem with stud keys or other small parts that are installed in large quantities. Inspection and verification during assembly or between firings is the only way to directly detect missing or extra parts. One verification method might involve accurately weighing subcomponents before final assembly. Missing/extra parts may also result in another failure type that may be detected in flight, e.g. loose bolts.

Torque, Vibration, and Excess Travel - These measurements have all been used as criteria for assessing turbopump condition. All three have the potential for being performed in flight and could be used in combination to adequately evaluate turbopump condition.

Tolerance - Tolerance problems can possibly be detected in flight by optical methods, but ground inspection is usually required. Optical methods for enhancing ground-based inspection of injector parts could possibly save time, but these techniques will need extensive development.

Information on potentially useful transducers for detecting particular failure modes came from several sources including the diagnostic survey conducted as part of this study, the Rocketdyne Reusable Rocket Engine Maintenance Study, Final Report, and Battelle's past experience. Detailed descriptions of several promising sensors and diagnostic techniques are included in this section's recommendations or in the section covering the diagnostic survey.

To evaluate diagnostics for detection of particular failure modes, a Battelle developed tool, the Failure Information Propagation Model (FIPM), has been used and is described in detail in a subsequent section of this report. This tool can be used to evaluate the information at a transducer location and to assess the ability of the entire transducer set to identify engine failure modes.

The results of the measurement parameter analysis for each component are described in tabular form in Reference 1, Appendix J. A sample table of results is shown in Figure 8. The failure modes, their causes, rankings, and effects are listed in the tables. The possible measurable parameters for each failure mode are listed along with possible in-flight and between-flight sensors or techniques. Additional comments are also supplied to indicate relative strengths and weaknesses of the measurement techniques.

For most failures, the possibility exists to trend or detect their occurrence with conventional transducers that are already being used on the SSME. The problem is that current engine transducers may not be strategically located for detection of many of these failures. Knowledge of the signal content is also insufficient to differentiate between the many possible failure modes detectable by a given transducer. There are also some transducing methods that need development, but which have excellent promise for detecting failure modes which are undetectable by conventional methods.

The use of sensor data for failure trending could reduce the amount of between-flight inspections. Any failure mode that involves a slow degradation or fatigue type of failure could be trended. Detailed descriptions of measurements that can be used for trending particular failure modes are included in the measurement parameter tables found in Reference 1, Appendix J. Many fatigue failures in the turbopumps and other components can be trended with mechanical and thermal load history information obtained by accelerometers, other vibration transducers, and temperature sensors. Injector and hot-gas component erosion can be trended with temperature measurements and, in some cases, pressure measurements.

| Failure Mode -Causes- | Rank | Effect | Measurable Parameters | Inflight Measurements | Between Flight Measurements | Comments |
|---|------|-----------------------------|--|--|---|---|
| Cracks, Ruptured Duct -vibration- -thermal- -no heat treatment- -defective welds- | 3 | Engine Fire | Vibration (F)(T) Temperature (F)(T)(D) Acoustic (B)(D) Loads (F)(T) Optical (B)(D) Performance (F)(D) Leak Detection (G)(D) Pressure (F)(D) | Accelerometer Thermocouple, RTD Acoustic Emission Strain Gages Holography (leak) Various (MCC) Pressure Sensor | Ultrasonic (leak) NDT, Visual Various | AE is a possibility for crack detection, but may be difficult to implement. Present instrument information may be helpful in detecting leakage, but may not be sensitive enough to stop the engine before catastrophic failure. Trending with vibration and temperature sensors could be helpful in tracking life limits. |
| Loose Stud Fasteners -wrong torque- -stretching- -soft keys- | 7 | Hot-gas leak Engine Fire | Vibration (F)(D) Torque (G)(D) Optical (B)(D) load (F)(T) | Accelerometer ? Strain Gages | Torque-meter Visual | Using some sort of alignment marks with an optical system for detection may be possible on flight or at least as ground check. Vibration data may indicate a loose fastener also. |
| G-5 Seal and MCC Ignition Joint Leaks -installation problems- | 7,1 | Engine Fire | Optical (B)(D) Leak Detection (G)(D) Temperature (F)(D) Acoustic (B)(D) Performance (F)(D) | Holography (leak) Thermocouple, RTD Acoustic Emission Various | Various Ultrasonic (leak) | Same as duct leaks. |
| Contamination -unknown- | 8 | Performance Degradation | Performance (F)(D) Optical (G)(D) | Various | Borescope, Visual | Not much can be done except some sort of monitoring of performance degradation. |

FIGURE 8. EXAMPLE OF MEASUREMENT PARAMETER TABLES

Conclusions

The conclusions drawn from the failure modes and measurement parameter analyses are:

- Turbopumps have the highest priority for in-flight monitoring, but many other components also have high-ranking failure modes which must be considered.
- Major accident failure modes have been random in nature and the commonly recurring failure modes generally have not been to blame. Many of the major accidents were due to either assembly, manufacturing, or design problems which must be considered in the development of a diagnostic system.
- Presently, many failure modes are detected too late to safely shut down the SSME with minimal damage. The propagation rate of many failure modes provides an extreme challenge in designing an effective diagnostic system.
- Test firing cutoff UCR data reveal that the present sensors can be valuable for reliably diagnosing many failure modes. This could and should be achieved with proper signal processing, pattern recognition (unique combination of sensor outputs), analytical redundancy (correlate outputs from upstream and downstream sensors), and development of more rugged sensors and cabling.
- Some recently developed and novel sensors could be useful for detection of critical failure modes, especially in the high-speed turbopumps. Some of these can target key failure modes that may be masked from conventional sensors. They are described in the diagnostic survey discussion or in this section's recommendations. In many cases, there will be a great deal of development required before these new sensors are flight ready. The most immediate gains may be made by improving the use of the present sensors.
- Many slow-developing fatigue or wear related failures can be trended by information from conventional sensors, both to

predict eventual failure and to reduce the amount of between-flight inspections. Such applications are possible for many turbopump and injector failure modes.

Recommendations

Diagnostic monitoring of the SSME can be improved by better use of present instrumentation, installation of more conventional sensors, and use of some recently developed sensing techniques which target specific failure modes. Three important steps for improving flight safety and maintenance costs are:

- Design of an integrated diagnostic system including both in-flight monitoring and ground inspection and maintenance.
- Improving failure diagnosis with conventional sensors by analysis of present flight and test firing data as well as assessment of signal processing and enhancement techniques to identify failure modes.
- Further development and testing of promising sensing techniques which target costly and hazardous failure modes that are difficult to detect with conventional sensors.

To design an effective diagnostic system for reduction of maintenance costs, turnaround time, and catastrophic failure risk; failure information in the entire SSME must be evaluated. The Failure Information Propagation Model (FIPM) is being used to evaluate failure information for all possible failure modes on the high-pressure oxidizer turbopump and assess sensing opportunities at various locations in the turbopump. Once the FIPM is completed for all components, a qualitative evaluation of a complete SSME diagnostic system can be made. The FIPM will help determine how better to use conventional and advanced technology sensors for in-flight monitoring and trending of information in conjunction with necessary ground inspections. An important aspect in the design of the complete diagnostic system is to incorporate an effective computerized information system for data processing and retrieval. Such a system would give maintenance personnel the relevant information to quickly assess and

complete between-flight inspection and maintenance and would also be adaptable to incorporate new diagnostic developments.

There are many opportunities to improve the capabilities of the present sensor set as well as possible additional conventional sensors. The key to developing the use of these sensors is analyze the recorded analog flight and test firing data. By looking at the full bandwidth of the sensors, combining various sensor outputs, and correlating the signals with the known failure occurrences, diagnosis of many failure modes may be improved. Also, the FIPM can be useful in identifying possible applications for the present sensors and situations where additional conventional sensors would be helpful. The reliability problems of the present conventional sensors can be attacked by technological gains in hardening the sensors and through analytical redundancy in checking the validity of the sensor outputs. Analytical redundancy could reduce the number of sensors needed and thus reduce the amount of sensor repair and replacement. Specific applications are detailed in the measurement parameter tables in Reference 1, Appendix K.

Some new sensors may see applications on the SSME in the next couple years and others could be developed for use on the engine within five years. Most of these new or additional sensors target specific failure modes that are both costly and not presently detectable by conventional sensors. A list of the most promising sensors or sensing techniques follows:

Partially Developed and Tested

- Isotope Wear Detection - Between-flight nonintrusive detection of slowly developing wear-related failure modes. Potential uses, mainly in the turbopumps, include bearings, seals, and turbine blades. Cannot detect cracking or pitting. Presently being tested by Rocketdyne with funding from NASA LeRC.
- Ultrasonic Doppler Transducer - Nonintrusive means of detecting shaft vibration through solid and liquid interfaces. Extremely sensitive to imbalance and other RPM

related vibration and may be useful for detecting other failure modes on the information rich shaft assemblies of the turbopump. It can detect cavitation, bearing wear, and seal rubbing. Developed by Battelle and tested at NASA MSFC in the mid-70's.

- **Fiberoptic Deflectometer** - Possibly more durable than conventional accelerometers and can potentially target specific vibration problems that need intrusive measurement capabilities such as bearing wear. Presently being tested at NASA LeRC by Rocketdyne.
- **Ultrasonic Flowmeter** - Has been tested as a means of nonintrusively measuring flow through ducts. The mounting conditions, however, have caused a duct to rupture. With proper design of the duct and transducer mounting, this sensor is believed to be a reliable method of detecting flow rate.
- **Optical Pyrometer** - For possible trending of turbine blade cracking. May have resolution and calibration problems, but there is no other acceptable method of detecting this failure mode at present. Under test by Rocketdyne with funding by NASA LeRC.
- **Borescope Image Processor** - Off-the-shelf packages are available to enhance the visual inspection of internal parts. New generation borescopes may be much better for low-light situations.

Devices with Major Development Efforts Needed

- **Magnetic Wear Detector** - A small experiment at Battelle showed that the ball passage rate can be monitored by a Hall-effect sensor. Bearing ball wear will change the contact angle and thus the ball speed. If the signal can be cleaned up enough, higher order effects may also be detected. Could be used as either a flight sensor or ground inspection method.

- Acoustic Emission Detectors - Possible in-flight applications for detecting cracks and leaks of quickly propagating failure modes. May have resolution problems in high background noise environment. Cracks and leaks are by far the most predominate types of failures.
- Laser Doppler Velocimeter - Can measure flow speed and direction, but needs access via an optic fiber through a hole or "window".
- Tracers Added to Helium Leak Detection - A radioactive tracer (Krypton, Tritium, etc.) could improve leak detection for ground-based applications.
- Holographic Leak Detection - Has the possibility of detecting and locating leaks faster and more effectively than the present helium method. Being investigated in a detailed Rocketdyne study.
- Exo-Electron Emission - May be useful in ground inspection for cracked parts. Also detailed in Rocketdyne study.

All of the above measurement applications should be evaluated for cost effective means of improving the present diagnostic system, but the most immediate improvements should come through studying the on-board sensors.

(This Page Intentionally Blank)

DIAGNOSTICS SURVEY

A survey of the state of the art of machine diagnostics was performed as the second task in the SSME study. In this survey, a general look was taken at the area of machine diagnostics across three rather broadly defined application areas:

1. Diagnostics for liquid-fueled rocket engines,
2. Diagnostics for aircraft engines,
3. Diagnostics in relevant non-aerospace industries.

The survey involved interviews with experts in a broad range of industries, NASA, and the military. In addition, relevant Battelle experts were interviewed and the literature was reviewed. The current diagnostic methods for the Space Shuttle Main Engine (SSME) were also examined and the relevant survey findings were identified for potential use on the SSME.

Survey Approach and Methodology

Approach

This diagnostic survey has two objectives: (1) the determination of the state-of-the-art of machine diagnostics, and (2) the identification of new, candidate diagnostic techniques and/or approaches for potential application to the SSME. Throughout this effort, the focus is on those techniques that are considered to be off-the-shelf, or mature areas of research and development.

The intent of the diagnostic survey is to be broad, spanning as wide a spectrum of industries as possible. Within the general area of machine diagnostics, three topics are considered:

1. Maintenance logistics and strategies,
2. Diagnostic techniques,
3. Design approaches for diagnostic systems.

Because of its breadth, this study does not attempt to focus on any specific technique or approach in great detail. Throughout the

survey, only enough detail was sought to permit an assessment of the usefulness of the techniques under study.

Methodology

There are two phases in diagnostics survey, a state-of-the-art survey and the subsequent assessment of the survey findings. For the survey phase, we selected three application categories:

1. Diagnostic systems for liquid rocket engines,
2. Diagnostic systems on civil and military aircraft,
3. Diagnostic systems in non-aerospace industries.

Information was gathered using literature reviews and interviews with a number of industry, government, and military experts. Figure 9 depicts the overall survey strategy.

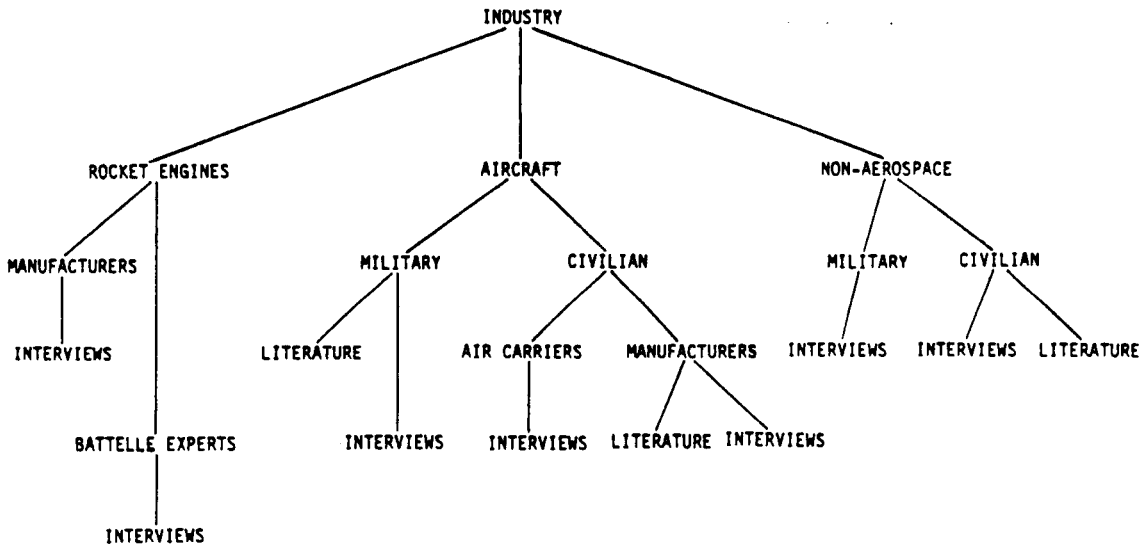

FIGURE 9. STRATEGY FOR STATE-OF-THE-ART SURVEY OF MACHINE DIAGNOSTICS

The second phase of the Diagnostics Survey was a preliminary assessment of the survey findings to screen out those that were not considered relevant to the SSME. This was done in two steps:

1. The diagnostic systems and maintenance strategy currently employed for the SSME were reviewed.
2. The survey findings were reexamined in light of the current SSME environment, and those that were not considered useful were dropped.

Information sources for the review of current SSME diagnostic systems and maintenance practices were NASA and Rocketdyne experts, and selected published reports.

Diagnostics Background

By its very nature, machine diagnostics encompasses a broad set of disciplines. Much of the scientific knowledge necessary to design and fabricate machines, as well as to understand the physics of their failures, falls under the technological umbrella of machine diagnostics. Because of this breadth, it is necessary to provide an organization through a hierarchy of related functions. This organization results in a logical, manageable set of elements.

Definitions

We begin our discussion with a set of definitions to remove ambiguity in terminology. The following are taken from Reference 3-8:

- FAULT DETECTION - the act of identifying the presence of an unspecified failure mode in a system resulting in an unspecified malfunction.
- MALFUNCTION - an inability to operate in the normal manner or at the expected level of performance.
- FAULT ISOLATION - the designation of the materials, structures, components, or subsystems that have malfunctioned. Fault isolation extends fault detection to the detection/identification of the specific part that must be repaired or replaced in order to restore the system to normal operation.

- FAILURE DIAGNOSIS - the process of identifying a failure mode or condition from an evaluation of its signs and symptoms. The diagnostic process extends fault isolation to the detection/identification of the specific mode by which a part or component has failed.
- FAILURE MODE - a particular manner in which the omission of an expected occurrence (or performance of a task) happens.

By examination, the universe of states for any given system may be partitioned into two overlapping regions, operational states and faulty states (see Figure 10). This partitioning does not, however, produce a dichotomy, and there is overlap between the two regions.

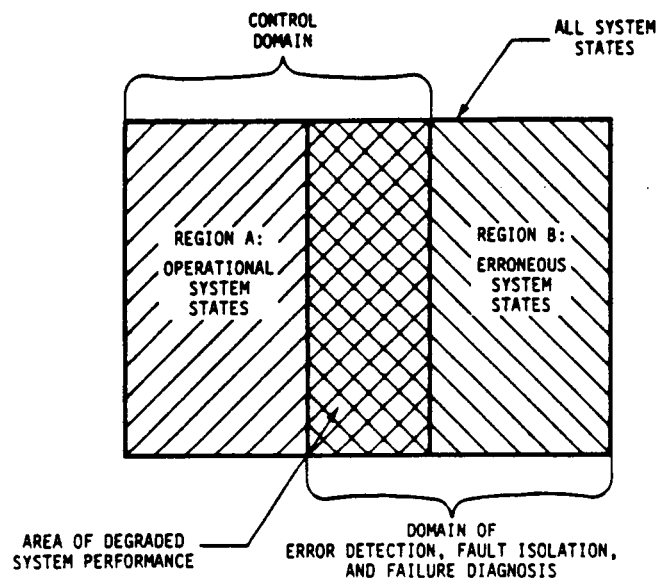

FIGURE 10. PARTITIONING OF SYSTEM STATES INTO OPERATIONAL AND ERRONEOUS STATES. Notice the Overlap.

This area of overlap represents states of degraded system performance. In general, the region of operational states represents the control domain, whereas the faulty states, constitutes the domain of fault

detection, fault isolation, and failure diagnosis. The above definitions can now be rewritten so that they are in terms of these states.

- FAULT DETECTION - the identification of a system state lying within the region of faulty states.
- FAULT ISOLATION - identification of a class of system states within the region of faulty states which classify the malfunction of a specific module or component.
- FAILURE DIAGNOSIS - identification of a system state within the region of faulty states which classifies a specific failure mode of the malfunctioning module or component.
- STATE IDENTIFICATION - the determination of the condition or mode of a system with respect to a set of circumstances at a particular time.

In addition to redefining some of the diagnostic-related elements, one can also express the concept of control in terms of system states.

- CONTROL - the identification of a current system operational state and the subsequent adjustment of the system so as to maneuver it to another desired operational state.

From the above discussion the following, self-evident conclusion results:

All types of detection associated with error perception, fault isolation, failure diagnosis, and system control are classes of state identification.

This conclusion is quite important in that it allows the grouping of the various facets of machine diagnostics, fault detection, fault isolation, and failure diagnosis under the more general topic of state identification. Additionally, since detection for control purposes is also a class of state identification, the importance of considering both the machine diagnostics and control in an integrated fashion is emphasized. Therefore, there exists a common denominator, state identification, around which this study is logically focused.

State Identification Process Hierarchy

One can specify a hierarchy of elements that are necessary for the state identification process. First, at the lowest level, information about the system or machine in question must be gathered. Second, once this information has been gathered, it must somehow be reduced to a manageable set of relevant features. Finally, at the highest level, that set of features can be used to perform the state identification. This hierarchy of functions is shown in Figure 11.

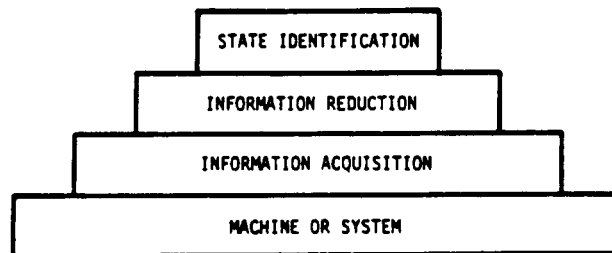

FIGURE 11. THE HIERARCHY OF PROCESS REQUIRED FOR STATE IDENTIFICATION

Information Acquisition

The potential sources of information about a given system or machine necessary for state identification are: specifications, history, sensors, and inspection. Optimally, all of these are utilized in the state identification process for machine diagnostics.

Specifications. Specifications are those documents which define the normal operating characteristics of the system or machine. Deviations from this norm may be caused by component failures, design errors, or both.

If a given system is operating according to specifications, it is in that sector within the region of operational states which does not

overlap with the region of faulty states (see Figure 10), otherwise it is in the region of faulty states. The specifications define the performance explicitly for the system controller, and implicitly for the system fault detection mechanism.

History. History about a system or machine's performance can be of a short-term or long-term nature. Short-term history represents those events which are related to one another and take place within the physical or characteristic time cycles of the machine. For example, all events occurring within the decay time for a pendulum might be considered short-term history. Long-term history consists of those events which occur in a time frame greater than that considered to be short-term (as previously defined). Observation of all events, whether they are of short-term or long-term historical nature are made using sensors or by inspection (see below).

Sensors. The transducers that measure the various physical parameters. Sensors may either be permanently installed on-board a machine or used as part of test instrumentation. The sensor output information is often called raw data. This raw data must be reduced to a set of features in order to perform state identification for diagnostic or control purposes.

Inspection. Inspection techniques are often used in lieu of sensors. In effect, a human serves the function of a wide-band sensor. Some tools are available to assist the human during the inspection process. The physician's stethoscope is an example of such a tool.

Information Reduction

Having acquired information about the performance of a machine or system, it must be subsequently processed and reduced to produce a set of features from which to perform the state identification. Usually, this part of the process involves the reduction of the information by removing that which is redundant or irrelevant. Sometimes data from several

sources are combined to generate features which cannot be or which have not been physically measured at a single place or time. A commonplace example of this is the combination of sensory data about a machine, along with its long-term history, in order to derive a feature which describes a machine's failure trends.

There are two principal means by which this reduction of information takes place, signal processing and/or human expert analysis. The difference between these two approaches may be seen simply as the difference between machines and humans. Signal processing can be accomplished in a number of machine domains:

- Analog electronics (continuous or discrete),
- Other analog domains,
- Digital electronics (hardware only),
- Hardware and software.

Human expert analysis may be accomplished with or without the assistance of mechanized tools. A mechanic listening to the noise of an automobile engine to discern the tapping of a valve exemplifies the latter case. An automotive engineer observing the output of an acoustic spectrum analyzer to make the same determination represents the former case.

State Identification

Having acquired information about a system or machine, and subsequently generating a set of relevant features, the state identification must be performed. As is the case with information reduction, the same identification can be carried out either by humans or automated devices.

In general, there are three approaches for automated state identification:

1. Pattern recognition (with the most trivial case being a table lookup)
2. Nonlinear filters (with the simple algorithm representing the most trivial case)
3. Expert systems.

In the specific cases where state identification is used for error detection or fault isolation, a fourth technique is at our disposal, i.e., voting. In the voting process, a society of identical hardware modules operate in parallel to highlight any nonconformists (malfunctioning modules).

Human-based decisions (state identifications) are the most common in the diagnostic/maintenance areas. In the vast majority of these cases, the expert has no assistance (other than perhaps another human expert). Recently however, the use of computer expert systems as decision aids is gaining acceptance. Witness, for example, the increasing commercialization of computer-based expert systems to assist in medical diagnosis.

Summary and Conclusions

In an effort to find a common denominator for the various aspects of machine diagnostics (namely fault detection, fault isolation, and failure diagnosis), it was determined that all were classes of the more general process of state identification. In addition, it was concluded that detection for control purposes was also a class of state identification.

The process of state identification can be thought of as a hierarchy. First information must be gathered about the system in question. Then, the information must be reduced to a set of features. Finally, based upon those features, an identification of the system state may be accomplished.

Viewing this hierarchy from the perspective of machine diagnostics versus machine control, we can gain insight into the interaction between those two functions. Revising the pyramid of Figure 11 we obtain that of Figure 12. It is evident from the above discussion that machine control requires many of the same elements as do machine diagnostics. As shown in Figure 12, there is every reason to expect that a sharing of hardware between the control and diagnostic functions is both possible and desirable. Reliability theory tells us

that the addition of any component into a system will always increase the likelihood of failure--even though the component may serve a diagnostic purpose (it is possible that system reliability could be increased if the addition of the component in question added redundancy of some type). By allowing control and diagnostic functions to share resources, system reliability is kept to a maximum. Because diagnostics help to reduce system down-time, once a failure has occurred, system availability is improved.

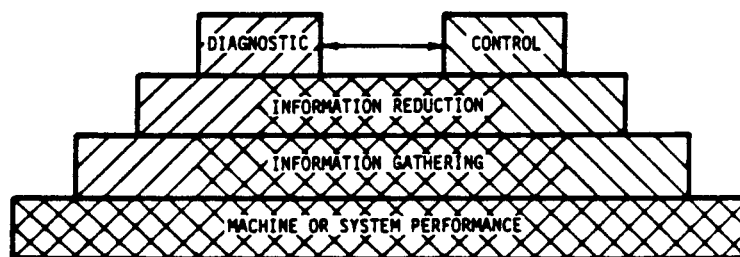

FIGURE 12. MACHINE CONTROL VERSUS MACHINE DIAGNOSTICS.
NOTE THE OPPORTUNITY FOR SHARING RESOURCES

Taking the elements from the above hierarchy and using the classifications discussed earlier in this section, Table 2 is formulated. We are now in a position to use this classification as a tool for organizing the results of our diagnostic survey.

SSME Diagnostic and Maintenance System Overview

This section presents a brief description of the SSME diagnostic and maintenance system. It should be noted that the current maintenance/diagnostic structure is highly complex. In the interest of brevity, the elements chosen represent rather coarse groupings of the numerous related components. Nevertheless, it is felt that the categorizations are accurate and that the description is therefore a good representation of the diagnostic system.

TABLE 2. BREAK-DOWN OF THE DIAGNOSTIC HIERARCHY

| | | |
|-----------------------|-----------------------|----------------------|
| DIAGNOSTIC | AUTOMATED DECISION | PATTERN RECOGNITION |
| | | NONLEAR FILTERS |
| | | EXPERT SYSTEMS |
| | | VOTING SYSTEMS |
| | HUMAN EXPERT OPINION | HUMAN ONLY |
| | | MACHINE ASSISTED |
| INFORMATION REDUCTION | SIGNAL PROCESSING | ANALOG ELECTRONICS |
| | | OTHER ANALOG DOMAINS |
| | | DIGITAL ELECTRONICS |
| | HUMAN EXPERT ANALYSIS | HUMAN ONLY |
| | | MACHINE ASSISTED |
| INFORMATION SOURCES | SPECIFICATIONS | |
| | HISTORY | SHORT TERM |
| | | LONG TERM |
| | SENSORS | ON-BOARD |
| | | TEST INSTRUMENTATION |
| | INSPECTION | HUMAN ONLY |
| | | MACHINE ASSISTED |

The diagnostic system elements for the SSME may be broadly categorized as either "on-board" or "ground-based". For the sake of this discussion, by the term "on-board" we mean those diagnostic elements that are physically close to the engine, whether it is flying on a Space Shuttle or operating on a test stand. "Ground-based" elements of the diagnostic and maintenance system are those that are not considered to be on-board ("everything else").

In addition to the "ground-based" versus "on-board" categorization of the SSME diagnostic elements, they may also be classified according to the diagnostic hierarchy discussed in the previous section. There are a number of levels in the hierarchy, the lowest of which is the plant level (the level containing the engine itself). The next-to-the-bottom level can be thought of as the information gathering level. All elements which have a role in the acquisition of information about the plant's (engine's) performance belong to this level. Control actuators also reside at the information gathering level. The next-to-the-highest level is termed the information reduction level. It is here that any signal processing or conditioning occurs. Finally, the highest

level is termed the decision level. At this level, diagnostic and control decisions are made.

Based upon the previously described hierarchical organization we can identify (albeit somewhat broadly) the various elements that comprise the diagnostic system for the SSME. Such an overview is given schematically in Figure 13. It must be noted that those elements which are classified as on-board (including crew) are meant to apply to test stand firings as well as in-flight service.

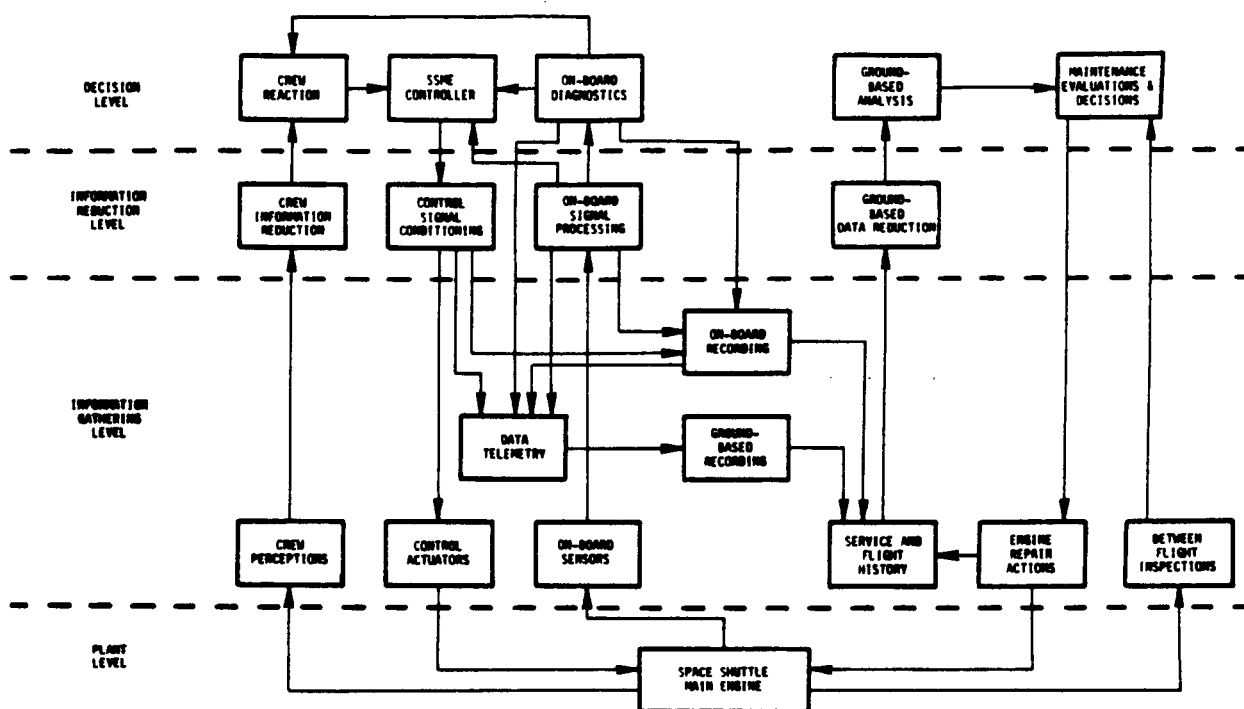

FIGURE 13. OVERALL SSME DIAGNOSTICS AND MAINTENANCE PICTURE

Information Gathering

There are two on-board elements which provide the function of data acquisition: crew perceptions and on-board sensors. The crew perceptions are those observations of the flight crew on the Orbiter, and the support staff during test stand engine firings. These observations

are results of the physical senses and should not be confused with information presented to the crew by the diagnostic subsystems.

A number of on-board sensors are used primarily for control purposes. The remaining sensors are dedicated to diagnostic functions. Some of the control related sensor outputs are also used for diagnostic purposes.

Aside from the data acquisition function, there are on-board elements for data telemetry and data recording. Nearly all sensor outputs are ultimately telemetered for ground-based analysis. A number of these data are also recorded on-board the Orbiter.

On the ground-based side, a large amount of diagnostic data comes from between-flight inspections. Data acquired by on-board subsystems are ultimately integrated with the results of ground-based inspections and engine repair actions to establish the engine flight and service history. This historical data represents a valuable information pool for detailed analysis.

Information Reduction

All of the data, whether acquired by sensor, observation, or between flight inspection must be reduced to a manageable set of features so that the appropriate diagnostic or control decision may be quickly and accurately made. Sensor data is characteristically reduced using signal processing techniques such as time integration or low-pass filtering. Observations and inspection results are typically reduced by the inspection specialists through the use of heuristics.

Diagnostic Decisions

The on-board diagnostic subsystem uses a basic form of pattern recognition. A table of "red lines", dynamically adjusted for changes in the engine's operational modes, is employed to flag potentially dangerous conditions and dictate responses. Similarly, the crew reactions represent a human pattern recognition resulting in well practiced responses.

Currently, the ground-based analysis employs an analytical model of the engine combined with heuristic-based decisions to identify potential trouble spots. This information is used to some degree to direct the between-flight inspections, and aids in the maintenance evaluations and repair decisions.

Summary

This section has presented a high level overview of the SSME diagnostic and maintenance system. The various diagnostic and maintenance elements as well as their interactions (or possible interactions) have been described and are depicted in Figure 13. The intent of the state-of-the-art diagnostic survey is to identify possible techniques to improve the performance of those elements and/or to improve the quality of their interconnections.

Survey Findings

This section presents the significant findings and highlights of the state-of-the-art diagnostic survey. These findings are broken down into three major application areas:

1. Liquid-fueled rocket engines,
2. Aircraft,
3. Non-aerospace industries.

Within each application area, the findings are further organized according to the hierarchical classification discussed in the previous sections.

Liquid-Fueled Rocket Engines

The principal sources of information for this part of the survey were rocket engine manufacturers, instrumentation vendors, Battelle experts, and NASA reports.

The SSME is unique in that it is the first truly reusable rocket engine not on an experimental vehicle. This fact, combined with a design which allows for smaller error margins than previous rocket engines, has dictated a much more comprehensive diagnostic and maintenance philosophy than any of its predecessors.

Data Acquisition. The vast majority of the sensing and instrumentation techniques are based upon well-seasoned approaches. In the case of on-board devices, such well-established transducers as thermocouples, pressure sensors, accelerometers, etc. are typically used. The data from these transducers are usually telemetered for ground-based analysis. Historically, manufacturers have not had a great deal of confidence in on-board instrumentation. Rocketdyne is currently under contract with NASA to develop new instrumentation as a part of an advanced condition monitoring system.

Ground-based inspections are characteristically manual in nature. Some instruments such as mass spectrometers have found application in the isolation of gas leaks. Some new techniques for data acquisition have been proposed and/or are under development, but none of those are yet considered to be mature products.

Signal Processing. Because of the basic nature of the diagnostic systems employed on prior rocket engines, minimal on-board signal processing techniques were used. The techniques used are basic in nature and have as their objective the enhancement of the signal-to-noise ratio or sensor signals. Ground-based analyses of telemetered data characteristically employ more sophisticated approaches.

Diagnostic Techniques. The sophistication of the diagnostic techniques used on-board previous rocket engines has been minimal. The most common real-time monitoring technique was based upon the violation of limits or "red lines". Post-flight analyses, were usually more thorough, relying on tools such as computer simulations.

Highlights. Items of particular interest which were obtained during the liquid rocket engine portion of the survey include:

Awareness of Need for Diagnostics. All of the manufacturers of rocket engines that were interviewed (Rocketdyne, Pratt and Whitney, and Aerojet) indicated an awareness of the need for comprehensive diagnostics on reusable engines. Rocketdyne, due to its involvement with the SSME, has already embarked on the development of a comprehensive condition monitoring system. Both Aerojet and Pratt and Whitney intend to develop such systems on future engine programs.

Current SSME Diagnostics. The engine monitoring system currently employed on the SSME has been successful from the standpoint of crew/vehicle safety. However, it is labor intensive and does not lend itself well to the quick turnaround objectives of the STS program. The on-board diagnostics are based upon violations of a series of safety limits ("red lines") some of which are dynamically allocated. The on-board sensor set includes the following:

- temperature - resistive temperature detectors, thermocouples
- pressure - strain gauge, piezoelectric
- tachometer - magnetic pickup
- position - potentiometers, RVDT, LVDT
- vibration - piezoelectric accelerometer
- flowmeter - turbine
- calorimeter - thermopile
- radiometer - foil.

These sensors are considered by Rocketdyne to be adequately reliable. Data from some of these sensors are telemetered for ground-based recording at 20 millisecond intervals during engine firings. The ground-based portion of the diagnostic system is centered around a series of routine and periodic inspections. The routine inspections include the following:

- external inspection
- internal inspections - HPFTP, HPOTP, MCC

- leak tests
- automatic/electrical checkouts.

Borescopes are used for some of the internal inspections. Instrumentation required for leak tests includes flowmeters and mass spectrometers. The periodic inspections involve the removal of either the HPOTP, HPFTP, or both. During this activity turbine blades are inspected using optical microscopy, and the respective preburner sections are inspected visually and with concentricity gauges. In addition to the physical inspections of the various engine components, the recorded flight sensor data is reviewed to identify anomalies. The results of this review are communicated to the inspection team when any action is deemed necessary.

Future SSME Condition Monitoring System. Rocketdyne is currently under contract with NASA LeRC to develop an advanced engine condition monitoring system. The first phase of this study involved an analysis of failure reports for a number of liquid-fueled rocket engines, including the SSME, J-2, H-1, F-1, RS-27, Thor, and Atlas. The failure reports were reduced by successive screening and the resulting reports categorized into sixteen general failure types.

- | | |
|---|--|
| • bolt torque relaxation | • bearing damage |
| • coolant passage splits | • tube fracture |
| • joint leakage | • turbopump face seal leakage |
| • hot-gas manifold transfer tube cracks | • lube pressure anomalies |
| • high torque | • valve fails to perform |
| • cracked turbine blades | • valve internal leakage |
| • failure of bellows | • regulator discrepancies |
| • loose electrical connectors | • contaminated hydraulic control assembly. |

Sensors were subsequently evaluated based upon their ability to aid in the detection of the sixteen failure groups. An implicit philosophy during this selection process was that one sensor (or group of

sensors) would be dedicated to each failure mode. A number of state-of-the-art and novel concepts were identified. The sensors selected from those concepts were:

- fiberoptic deflectometer
- optical pyrometer
- isotope wear detector
- tunable diode-laser spectrometer
- ultrasonic thermometer
- optical tachometer
- ultrasonic flowmeter
- digital quartz pressure sensor
- holographic leak detector
- thermal conductivity leak detector
- exo-electron fatigue detector
- connector continuity checking
- particle analysis.

Ultimately, the first three of these concepts were identified for development and testing. This program is currently in progress. Another of the sensors mentioned above, an ultrasonic flow meter, was tested during an NSTL test firing. Because of problems arising from the sensor mounting, a duct rupture occurred precipitating a catastrophic engine failure.

In addition to the identification of applicable sensors, the study identified and evaluated the required signal processing techniques for use with sensors to isolate the various failure modes. These techniques are:

- amplitude histogram
- RMS histogram
- filtered histogram
- cross correlation
- transfer function
- product histogram
- ratio histogram
- differentiated histogram
- phase diagram histogram
- time profile
- power spectrum density
- integral over threshold
- RPM profiles
- Cambell diagram

The various instrumentation vendors interviewed provided information regarding many of the currently implemented SSME and aircraft

test programs. However, little information was obtained regarding new or novel instrumentation concepts.

Ultrasonic Doppler Vibration Sensor. Under contract with NASA MSFC, Battelle's Columbus Division developed a shaft vibration sensor and successfully tested it on a J-2 rocket engine. The sensor was of a non-invasive nature and determined the velocity of shaft vibrations by measuring doppler shifting from reflected ultrasonic waves. Although a success, this sensor was never developed further or utilized.

Aircraft

Sources for this part of the survey included interviews with experts from the military, commercial air carriers, airframe manufacturers, engine manufacturers, and instrumentation vendors. Information was also gathered from literature and interviews with Battelle experts.

Aircraft engines and their diagnostics have received considerable attention over the years. This attention is due to a number of factors, including the military's emphasis on weapon system availability, the civilian air carriers' push to minimize maintenance costs, and the FAA's desire to assure safety and reliability. Consequently, this part of the survey yielded a good deal of relevant information.

The current diagnostic/maintenance philosophies in the Air Force and the civilian air carriers are similar. The Air Force is attempting to establish a policy termed "retirement for cause". This concept is most easily described as an interactive preventative maintenance program. Component failures are carefully analyzed and accurate life indicators are derived for the engine components. The components will then be replaced only when a component is deemed to have degraded sufficiently that it will not last until the next periodic maintenance cycle.

The air carriers have a slightly different approach to maintenance. Given the need to reduce ground time and keep the aircraft flying as much as possible, a modified life limit approach to maintenance seems to prevail. An engine is used until a component failure occurs,

albeit in some cases an incipient failure, or until life limits dictate a scheduled repair cycle. If the engine is being repaired after a component failure, additional components which would exceed their life limit prior to the next scheduled repair cycle may be replaced.

Both the military and the commercial carriers employ a multi-tiered maintenance structure. The first level is that of the flight line at which major modules are replaced. A second level is responsible for troubleshooting the modules that have been replaced so that they may be quickly placed back in inventory. The third (ultimate) repair level is that of the specialized shops. This level may also include the equipment vendors. Here the damaged components are repaired and returned to the inventory of good parts.

Data Acquisition. Commercial aircraft engines all come equipped with an array of accelerometers, temperature sensors, flow meters, pressure transducers, and tachometers. The presence of some of those transducers is due to FAA requirements placed on the manufacturers. While all of the airlines use the majority of the installed sensors, there has been some mistrust of the accelerometers. Historically, they have experienced high false alarm rates. As such, at least one airline removes them upon receipt of new engines. The sensor manufacturers insist that the current generation of sensors exhibit high reliability. Their claims seem to be substantiated by the number of airlines that do use the entire sensor package for sophisticated analyses such as trending.

Military aircraft engines usually carry many of the same transducers as commercial engines. They serve both control and diagnostic purposes.

In the area of ground-based test, visual inspections, borescope inspections, x-ray checks, eddy current checks, and oil analyses all find application. Some sophisticated instrumentation systems are employed to acquire data from engines in test cells. Temperatures, hot-gas flows and pressures, and other similar data are gathered for off-line analysis.

Signal Processing. The signal processing employed for data from on-board sensors is centered around the enhancement of signal-to-noise ratios. Techniques such as low-pass, high-pass, and band-pass filtering

are common place. Features are sometimes generated using straightforward approaches such as integrating acceleration signals to derive velocity information. Ground-based instrumentation employs similar signal processing approaches.

Diagnostic Techniques. The most common approach employed for on-board jet engine diagnostics relies on a table of limits. When a limit has been exceeded, the appropriate alarm is signaled and the response, if any, initiated. Recently, this approach has been extended or supplemented by some carriers who perform limited on-board trend analysis. Data gathered by on-board sensors are recorded at regular intervals (ranging from several seconds to several minutes). Trends are calculated in order to estimate when the measured parameters will exceed their "red lines". This estimate may be modified to allow for changes in the rate of degradation. Some air carriers are now relying on information from ground-based trend analyses to conveniently schedule engine repair.

One diagnostic technique used by both the military and the civilian air carriers merits discussion. This technique is referred to as "gas path analysis". Developed and popularized by Hamilton Standard, the approach involves the optimal estimation of the state, and subsequently the health, of jet engines. In practice, a mathematical model is developed which represents a simulation of a particular engine. Sensor data are then used as a gauge for the optimal adjustment of the model parameters. When those parameters exceed acceptable limits, a failure is declared.

At Kelly Air Force Base, the Air Force uses such a system for test cell analysis of engines. TWA has also recently purchased such a system from Hamilton Standard. In addition, TWA has initiated a program whereby sensor data is telemetered from their latest generation of aircraft, and a quasi-real-time analysis is performed to assess engine performance. The air carriers rely heavily on an integrated system where in-flight data is analyzed and used in conjunction with ground-based test results to plan maintenance actions.

An on-going research and development effort is focused on the concept of an expert system (artificial intelligence based computer program) for jet engine diagnostics. This concept is based on the

transfer of human expertise to the expert system computer program. Although these systems are maturing very rapidly, they are not yet considered to be off-the-shelf.

Highlights. Items of particular interest which were obtained during the aircraft portion of the survey include:

USAF Retirement for Cause. The USAF is in the process of implementing a maintenance policy referred to as "retirement for cause". In short, this policy requires that an experimental analysis be performed on each batch of engine components in order to accurately understand and predict the life limits in the presence of the potential failures. For example, the level of propagation that a crack in a turbine vane must attain before failing will be empirically determined. Once these life limits are known (or at least estimated), the engine monitoring systems and periodic inspections are used to track engine component failures. Only when the life limits are approached are the faulty components replaced.

USAF On-Board Diagnostic System. An on-board engine monitoring system similar to the AIDS (see below) was experimentally implemented on five tactical F-15A aircraft (F100 Engines). The parameters monitored were:

- augments fuel pump discharge pressure
- augments permission fuel pressure
- burner pressure
- fan/core mixing pressure
- fan exit duct pressure
- fuel pump boost pressure
- fuel pump inlet pressure
- fuel pump discharge pressure
- main breather pressure
- number four bearing scavenge pressure
- rear compressor variable vane pressure
- fuel pump inlet temperature
- main oil temperature
- compressor exit static temperature
- fan exit duct temperature
- diffuser case vibration
- inlet case vibration
- power level angle position.

The on-board data acquisition system monitored these parameters and subsequently transferred the data for ground-based analysis. Such analyses, in conjunction with ground-based tests were used as the basis for a maintenance program. On the whole, the experiment was considered to be successful.

Experience with Commercial Carriers. Three domestic air carriers were interviewed in addition to making a review of literature describing some of the maintenance policies of European airlines.

Nearly all carriers utilize a variation of the aircraft integrated data system (AIDS). This data system was specified by ARINC and has the following attributes:

- diagnostic information is centralized
- some data is available for in-flight analysis
- data is recorded on a cassette tape for later ground-based analysis.

A number of carriers have implemented engine monitoring systems which are also integrated with the AIDS. In these systems, important engine parameters are monitored in-flight such as gas pressures and temperatures, fuel flows, rotor velocities, lubricant temperatures, and vibrations. Engine condition reports are available during flight to the flight engineer for short-term trending analyses. Long-term trending is performed using the AIDS data tapes during ground-based analyses.

In addition to the engine monitoring systems, ground tests and inspections are used to identify failures and trends. Ground-based inspections may include:

- visual inspection
- borescope inspections
- x-ray checks
- eddy current checks
- spectrographic oil analysis
- ferrographic oil analysis

The general consensus in the European air carrier community is that such sophisticated diagnostic and maintenance programs are cost justified. The domestic air carriers are not quite so aggressive. TWA,

however, has a maintenance and diagnostic program which is very much along the lines of the European carriers. United Air Lines on the other hand, seems to employ a more conservative, people intensive approach to maintenance and diagnostics.

Gas Path Analysis. Hamilton Standard Division of United Technologies has been marketing a computer software package called Gas Path Analysis. This software relies upon a linearized mathematical model of a specific jet engine to estimate the performance characteristics of the engine's constituent modules using measured input parameters such as temperatures, pressures, spool speeds, and fuel consumption. The program also estimates the performance of the various sensors that are used to acquire the data used in the analysis.

The mathematics of gas path analysis is based on the premise that it is possible to linearize any thermodynamic cycle model by deriving matrices of influence coefficients which relate deviations in measured parameters and component performances to coefficients describing component faults for each of the engine's operating points. The equations solved are:

$$A = H X + \theta$$

$$Y = G_e X_e$$

$$\text{where } X = \begin{pmatrix} X_e \\ X_s \end{pmatrix} \text{ and } H = (H_e | H_s)$$

The significance of the various variables is as follows:

- Z is a column vector of measurement deviations or deltas
- Y is a column vector of performance deltas for the engines' constituent modules
- X_e is a column vector of engine fault deltas
- X_s is a column vector of apparent sensor errors
- H_e and G_e are the matrices of coefficients derived from the engines' mathematical model
- H_s is a matrix of sensor fault coefficients
- θ is a random vector denoting sensor non-repeatability.

The dimensions are such that there is an over-specified set of equations which are a result of analytical redundancy in the measured

parameters. It is also this fact which allows the determination of sensor errors as well as engine component malfunctions.

A number of air carriers use this technique for ground-based analysis. Some European carriers and TWA use the gas path analysis program for analysis of flight data. Other carriers and the USAF use it only for test cell analysis of engine performance.

Sensors and Instrumentation Development. The area of sensor development receiving the greatest amount of attention for flight applications is that of fiber optic sensors. These sensors are especially desirable from the standpoint of weight and noise immunity. At this stage of development, however, the fiber optic connector technology is not sufficiently robust to allow widespread use on flight engines. A recent NASA study has examined applications for fiber optic sensors such as:

- rotary encoders
- optical tachometers
- rotor blade tip clearance
- optical temperature sensors (pyrometers).

Optical pyrometers have also been used in experiments to accurately determine turbine blade life. Solar Turbines Incorporated has provided such instrumentation for a number of these experiments. Optical clouding due to the presence of combustion products has been the principal operational drawback of this type of instrumentation.

In the more general area of data acquisition, a number of instrumented engine core test programs have been carried out. An off-the-shelf system for telemetering data from an engine rotor is available from Acurex Corporation. These systems are not considered to be sufficiently robust for flight applications.

Expert Systems. There are at least two programs underway for the development of rule-based expert systems for jet engine diagnosis. On the military side, the Air Force has been funding such a development at General Electric. In the commercial sector, Boeing has also been developing an expert system for jet engine diagnosis.

Non-Aerospace Industries

Information sources for this part of the survey included interviews with experts in fields ranging from medical electronics to transportation systems. In addition, interviews were conducted with Battelle experts and relevant publications were reviewed.

In general, the industrial sector has been somewhat slow in recognizing the potential of machine diagnostics, but recently, there has been an increasing emphasis in this area. The motives for this interest are varied. For example, NRC regulations have had a strong influence on the nuclear power industry while customer support issues have had an impact on the use of diagnostics in the automobile industry. Whatever the motives, some interesting techniques have resulted which may ultimately be of value to the SSME program.

Data Acquisition. In the area of transducers, most industries have embraced the proven sensors, e.g., accelerometers, thermocouples, etc. The manufacturers of those devices have been developing more reliable and "ruggedized" transducers and recognize that their sensors will be located in progressively more hostile environments.

In terms of sensing concepts, a number of techniques in development or use merit discussion. These concepts are described in the following paragraphs.

In the nuclear power industry, a device known as a miniature accelerator or MINAC has been developed for radiographing pump housings. The device is placed inside the housing and photographic film is placed around the outside of the housing. Once activated, the MINAC generates radiation that penetrates the pump and exposes the film--from the inside-out. This device has simplified a difficult imaging problem.

For the conventional power industry, Solar Turbines Incorporated is under contract with the Electric Power Research Institute to instrument a gas power turbine with an optical pyrometer. The pyrometer is positioned to scan the passing turbine blades and provide measurements leading to accurate predictions of the blades' life.

A number of novel fiberoptic-based sensors have been under development. An example of this is the laser-doppler-velocimeter (LDV)

which measures the velocity, not speed, of moving material. The material being measured can be a solid or a fluid. Because of its optical nature, the information can be communicated from the moving medium to the sensor by optical fibers. This sensor is already finding application in the manufacture of synthetic fibers.

A new class of semiconductor devices for measuring the presence of various elements has been under development. This device is called an ion selective field effect transistor (ISFET). These devices have been proposed for measuring such parameters as hydrogen concentrations in gases, and glucose levels in human blood. ISFETs have certain stability problems that have not as yet been resolved.

Cooperative sensing schemes are finding increased usage. The principal behind this concept is not new: the design of the system or component to be examined is altered so as to provide a clear, unmistakable signature which is easily monitored. Putting a tracer in a gas to measure concentrations and flows represents a well developed application of this technique. In a more recent example, bearing balls were magnetized to allow the monitoring of their behavior by simple magnetic field sensors.

For the storage of performance data, the memory card, an extremely portable device, is gaining popularity. This device is comprised of a microcomputer and nonvolatile data memory in a very small package (typically the size of a credit card). Memory cards, because they are inexpensive and portable, can permit the highly accurate tracking and monitoring of modules and components as they progress through the repair cycles. Unfortunately, the storage capacities of the data memory are still limited.

Vibration monitoring is common in numerous industries ranging from petrochemical plants to paper mills. For example, at Exxon's petrochemical plant in Baytown, Texas much of the machinery is continuously monitored using a minicomputer and on-board accelerometers. The signal levels of the accelerometers are analyzed to determine trends. Based upon such trends, maintenance can be optimally scheduled. In this same plant, such phenomena as pump cavitation were also detected by more careful analysis of the accelerometer signals. However, the ability to gather this additional information has not been integrated into the monitoring system.

Signal Processing. In the realm of signal processing, the most impressive developments have been in the area of hardware. Integrated circuits are now available which perform such functions as real-time digital filtering or real-time Fast Fourier Transforms. A manufacturer of charge-coupled-device (CCD) arrays, EG&G Reticon, also manufactures semiconductor devices which perform many of the filtering and analysis functions in the discrete time analog domain. Prior to the availability of those devices, these filtering techniques were only possible using digital electronics.

In the continuous time domain, a number of sensors have been developed for specific applications to perform filtering functions in a non-electronic fashion. One well developed example of this approach is the use of a tuned acoustic transducer for the monitoring of predetonation in GM automobile engines. This approach was used by GM in an effort to minimize production costs.

In the field of automated inspection systems a good deal of progress has been made in image processing and image interpretation. Commercial systems are now available for the automated inspection of pieces on an assembly line for manufacturing defects. Similar techniques have been developed for the autonomous inspection of printed circuit boards. This area will likely continue to evolve due to the recent successes.

Recent research in the human factors associated with display technology is directed toward the presentation of high level information, rather than machine parameters, in a graphical format. In industries such as nuclear power, the operators of the systems need diagnostic information in a high-level and unambiguous format, thus, permitting the decisions to be made quickly and accurately via human pattern recognition.

Diagnostic Techniques. The approaches used in the industrial sector for making diagnostic decisions span the entire spectrum, from the simple table lookup technique employed on most automobiles, to expert system computer programs for the diagnosis of failures in train locomotives. Of the information gathered during this part of the survey,

there are several concepts worth mentioning. These make up the remainder of this section.

General Electric Corporation has developed an expert system (computer program) for the diagnosis of failures on railroad locomotives. In this approach, the computer program was written to reason and draw conclusions based upon a set of rules. The set of rules is derived from interviews with human experts in the area (that of repairing GE's locomotives). In operation, the expert system guides the actions of a repair technician. This is only one of several diagnostic "experts" that have been developed: Westinghouse's Steam Turbines Division has developed a diagnostic expert system for steam turbines. The Westinghouse program, moreover, identifies sensor malfunctions as well as turbine component failures.

On-going research in the area of non-linear diagnostic filters promises to improve their performance by increasing sensitivity and reducing false alarm rates. In one particular effort involving Case Western Reserve University and Bailey Controls Division of Babcock and Wilcox, an industrial heat exchanger will be the test bed for an improved non-linear diagnostic filter. The benefits of such research efforts are likely to be incremental in nature, but available in the relatively short term.

The commercial application of pattern recognition based upon statistically derived and/or empirically determined features has been a reality for a number of years. The benefits of this approach is that the computation times for making decisions about a machine's performance can be very brief. Other computationally oriented techniques, non-linear diagnostic filters and expert systems, typically require substantially more time than pattern recognition. Historically, most pattern recognition systems have been custom tailored to the signatures of single specific machines, rather than, for example, other identical machines. This shortcoming has been addressed through the use of adaptive pattern recognition systems.

Vibration trend analysis is becoming a commonly used technique, especially in industries such as petrochemicals and paper manufacturing. This technique usually involves the monitoring of vibration sensors (most often the integrated outputs of accelerometers) to watch for change. The

rate of increase is estimated, and repairs scheduled according to the estimated time until a failure occurs.

Predictive diagnostics based upon ferrographic analysis of lubricant has been a reality for a number of years. This technique is based upon the gathering and analysis of wear particles to determine the mechanisms and severity of wear. While there are machine mounted sensors available for automated ferrographic analysis, the most thorough analyses are performed off-line using bichromatic microscopy.

Voting systems have been used to address anticipated failures (i.e., those failures that result from known component failure modes). However, unanticipated faults due to such causes as design errors cannot be addressed by voting systems. The more complex a machine, the greater is the likelihood of latent design errors.

Recommendations

Given the nature of the SSME environment and maintenance structure, several of the approaches and techniques identified in the previous section are recommended. We will hold to the same organization that has been used throughout this report. These recommendations are further summarized in Table 3.

Data Acquisition

To the extent possible, those existing on-board sensors which have experienced reliability problems, should be considered for replacement. As existing sensors are continually improved for sensitivity and durability, they should be examined and, as warranted, tested and considered for use on the SSME. A sensor data base would be beneficial for both the SSME, and for future rocket engine development programs.

TABLE 3. SUMMARY OF DIAGNOSTICS RECOMMENDATIONS

| Diagnostics Category | Recommendations | |
|-----------------------|---|--|
| | On-Board | Ground-Based |
| Data Acquisition | <p>More Reliable Sensors</p> <p>Increased Bandwidth for Existing Accelerometers and Transducers (pressure, temperature, flow, and speed)</p> <p>Additional Conventional Sensors</p> <p>Extensive Data Recording</p> <p>Continued Development of:</p> <ul style="list-style-type: none"> Optical Pyrometer Fiber Optic Deflectometer Ultrasonic Doppler Transducer Ultrasonic Flow Meter | <p>Continued Development of Isotope Wear Detector</p> <p>Extension of Isotope Wear Detector Concept to Include Ferrographic Analysis</p> <p>Use of Tracer Elements (Tritium or Sulfur Hexafluoride) for Leak Detection</p> |
| Signal Processing | <p>Improve S/N Ratios by Spectral Filtering and Noise Cancellation</p> | <p>Image Processing to Enhance Borescope Inspections</p> |
| Diagnostic Techniques | <p>Analysis and Development of Pattern Recognition Diagnostic System</p> | <p>Develop Gas Path Analysis Model of SSME</p> <p>Evolve Gas Path Analysis Model to Include Non-Linear Diagnostic Filter</p> <p>Establish and Maintain Integrated SSME Data Base (diagnostic and maintenance)</p> |

The on-board sensors should be more effectively used. For example, the accelerometers currently on the SSME are only used for the RMS values of their outputs. There is undoubtedly a great deal of information available in the higher frequency harmonics that is not being used. The full bandwidth of all existing sensors should be recorded on board and the data later used for detailed ground-based analysis. It also may be possible to telemeter this recorded data while the STS is on orbit.

It is estimated that upwards of 85 percent of all failures are intermittent in nature. Over the course of our survey, two approaches to the isolation of intermittent failures were identified: marginal testing and extensive logging. The use of marginal testing techniques on the SSME is not feasible. Therefore, we recommend that extensive on-board recording of the engine be performed. By analyzing this extensive amount of data, either on the ground or on-board, intermittent problems may be identified and isolated. In addition, the extra sensors required for such monitoring will augment the analytical redundancy of the diagnostic system.

The sensors proposed by Rocketdyne for the monitoring of turbomachinery should be carried through to application. Specifically, the optical pyrometer, fiberoptic deflectometer, and isotope wear detectors, will significantly improve the information available on the health of the turbopumps. In addition, the isotope wear detector program should be extended to encompass ferrographic analysis. Numerous precedents suggest that this type of analysis would be valuable for predictive diagnosis.

For ground-based inspections, we recommend that tracing elements should be considered to aid in the detection of hydrogen and other fluid leaks. It is felt that this would result in the simplified sensing apparatus.

Signal Processing

For ground-based tests, image processing should be used to augment certain inspection processes, especially the borescope

inspections. It is believed that such techniques could both improve the accuracy, and reduce the time required for inspections.

For on-board instrumentation, more elaborate signal processing will be required. Given the noise environment of the SSME, both spectral filtering and statistical noise cancellation techniques could be used to provide improved signal-to-noise ratios. High signal-to-noise ratios are essential if the existing sensors are to be more fully utilized.

Diagnostic Techniques

In the arena of diagnostic techniques there are three recommendations, one for on-board diagnosis and two for ground-based analysis. The principal purpose of the on-board diagnostics is to avert rapidly developing, catastrophic failures. Because of the speed of diagnosis and level of accuracy required, pattern recognition is the only realistic technique. To increase the coverage and accuracy of the on-board diagnostic system, a pattern recognition-based diagnostics should be considered.

For ground-based analyses, an effort to improve the analytical model for the SSME should be undertaken. In conjunction with such a model, a non-linear diagnostic filter should be developed. This effort might begin by initiating a gas path analysis program, and improving the analysis on an incremental basis. It may even be possible to run such a program in real-time based upon telemetered data (given adequate computing resources). If the system is sufficiently accurate, detailed trend analysis capabilities could result.

Finally, a thorough and highly integrated data base should be established to track and correlate information about engines and components. Information from on-board sensors, ground-based inspections, repair actions, and component histories should be included. Analysis of this data base must be made highly interactive to be most effective. Ultimately, such a data base could benefit the SSME maintenance staff, the operations staff, and the engine component manufacturers.

(This page intentionally blank)

SSME DIAGNOSTIC EVALUATION

The third task of the SSME study assimilated the outputs of the SSME failure data review and the diagnostics survey and used this information to evaluate the current SSME diagnostic system. The principal objective of this task was to identify potential means for improving the availability of high-quality, pertinent engine data. This information could be used both in-flight and on the ground to assess the condition of the SSME and its respective components. To accomplish this objective, an analysis tool (Failure Information Propagation Model) was selected to perform a systematic examination of the diagnostic information in the SSME. The Failure Information Propagation Model (FIPM) is discussed in this section. Also included is a description of the initial application of the FIPM to an SSME component.

Issues and Approach

To evaluate the overall SSME diagnostic system, the information gathered during the failure data review and diagnostic survey was integrated and analyzed. At the outset of this evaluation task, the following data were available:

- Results of the SSME failure data review
- Knowledge of the existing SSME inspection and maintenance process
- Knowledge of the current SSME sensors
- Information on sensor research and development underway for the SSME
- Results of the diagnostic survey.

This information provided a solid foundation for performing the required evaluation.

The first step in the analysis was to select the actual tool or technique to be used. To facilitate selection of a suitable analysis method, an overall approach was defined for the task. The approach adopted centered on addressing several key diagnostic issues. These issues included the following:

- What additional diagnostic information is available to the existing SSME sensors?
- Are there any information rich test points on the SSME that should be instrumented? If so, which sensors should be considered?
- How can we optimize the placement of additional sensors so as to minimize their total number and cost while maximizing their information gathering potential and reliability?
- Which instrumentation research and development areas represent the best investment relative to the diagnostic needs of the SSME?

The common denominator for all of the issues mentioned above is an understanding and characterization of the engine failure information and its flow paths.

The major focus of the initial effort on this task was directed, therefore, at finding a suitable means to represent the SSME failure information and at developing a data format which could be easily manipulated to address each of the above issues. The tool which appeared to satisfy all of the proposed requirements was the Failure Information Propagation Model (FIPM). The FIPM concept is discussed in the following subsection.

Failure Information Propagation Model

The Failure Information Propagation Model (FIPM) is a technique developed by the Battelle Columbus Division to qualitatively evaluate the potential test points in a system. The objective of this qualitative evaluation is to assess the information bearing value of each test point. The FIPM basically divides the system under analysis into its principal components or functions, describes the failure modes for these components, catalogs the physical connections between the components, details the flow of failure information through the various connections, and groups the failure information according to signal properties. It must be emphasized at this point that the FIPM models the propagation of failure information and not the failure itself. The model assumes that

the system being depicted is in a near-normal state of operation. The failure information flow is described for the instant of time immediately following a given failure.

The FIPM was initially developed to evaluate the factors affecting image quality in a photographic copy machine. This proprietary study was performed for an industrial client. Due to the nature of the system involved, this analysis was primarily concerned with the electronic functions of the device. Subsequent to this study, the FIPM was applied to an ion chamber and a home furnace. All of this work preceded the FIPM's consideration for this task. As a result of this early work, the FIPM has demonstrated the capability to adapt to a broad range of mechanical and electronic systems.

Three principal applications exist for the output of this model. These applications are:

- Design of sensor systems for new devices or components
- Evaluation of existing sensor systems to maximize the information yield
- Identification of sensor research and development needs to target key diagnostic data.

These important features of the FIPM made it especially attractive for use in the SSME diagnostic evaluation.

FIPM Example

The formulation of an FIPM must begin with the identification of the modules (components or functions) that comprise the system being evaluated. These modules may be piece parts, subassemblies, or subsystems depending on the level of detail sought. In the case of a typical exhaust fan, which is used here solely as an example, the constituent modules are subassemblies which have been selected to illustrate a top-level FIPM. In the case of the high-pressure oxidizer turbopump (HPOTP) FIPM which will be discussed later in this section, the constituent modules generally are piece parts.

The modules selected to illustrate the FIPM concept for the exhaust fan are the AC motor, the fan belt, the fan, the fan bearing, and the frame which supports these components. These elements are shown in Figure 14. The resulting model is very simple in that the AC motor actually has both electrical and mechanical parts, the fan has both blades and a pulley for the drive belt, etc. It is recognized that this model ignores many factors which would be considered in a thorough engineering analysis.

The network of connections between the exhaust fan modules is depicted in Figure 15. As indicated in this figure, the motor is mechanically mounted to the frame and transforms electrical power into mechanical power through friction with the fan belt. The fan belt also is connected by friction to the fan. The fan and frame are joined through the bearing by means of rolling elements. A thermal connection also exists, in normal operation, between the AC motor and the frame. The final element in the network is an air flow path out of the fan.

The failure modes of each of the exhaust fan modules is shown in Figure 16. It should be noted that these failure modes do not include mechanisms which are external to the module. Failures due to such outside causes as fire, explosion, or mechanical damage are not considered. Events such as fire in the fan motor also are not considered since these are actually effects of more fundamental failure modes. It should be reiterated that the FIPM is modeling the situation immediately following a failure and not the longer-term effects and consequences of that failure.

The occurrence of any exhaust fan failure mode produces failure information which can be detected externally to the component and which will, in general, be transmitted to adjacent components. An assessment of the failure information propagations for the exhaust fan example is shown in Figure 17. It is interesting to note that, in this example, all of the failure modes transmit failure information to all of the other modules. The large amount of failure data which is available at any given connection in the system is evident in this figure.

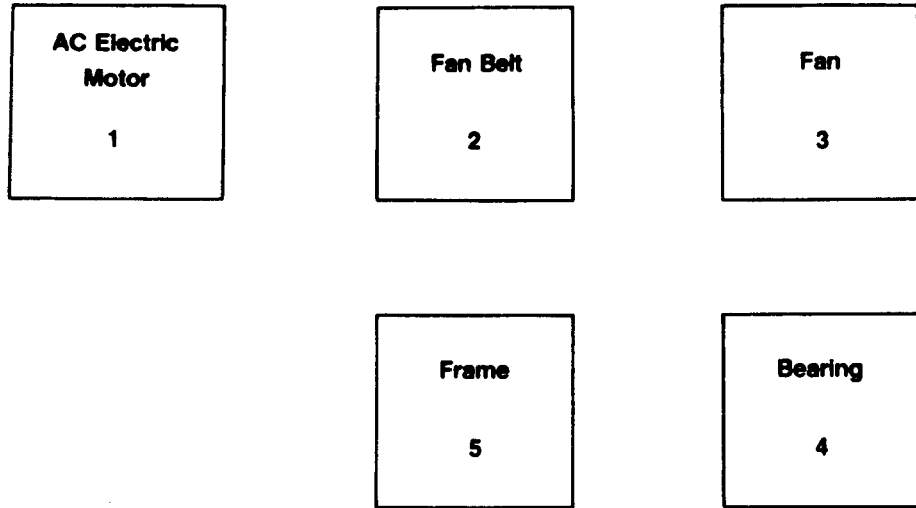

FIGURE 14. MODULES COMPRISING EXHAUST FAN FIPM

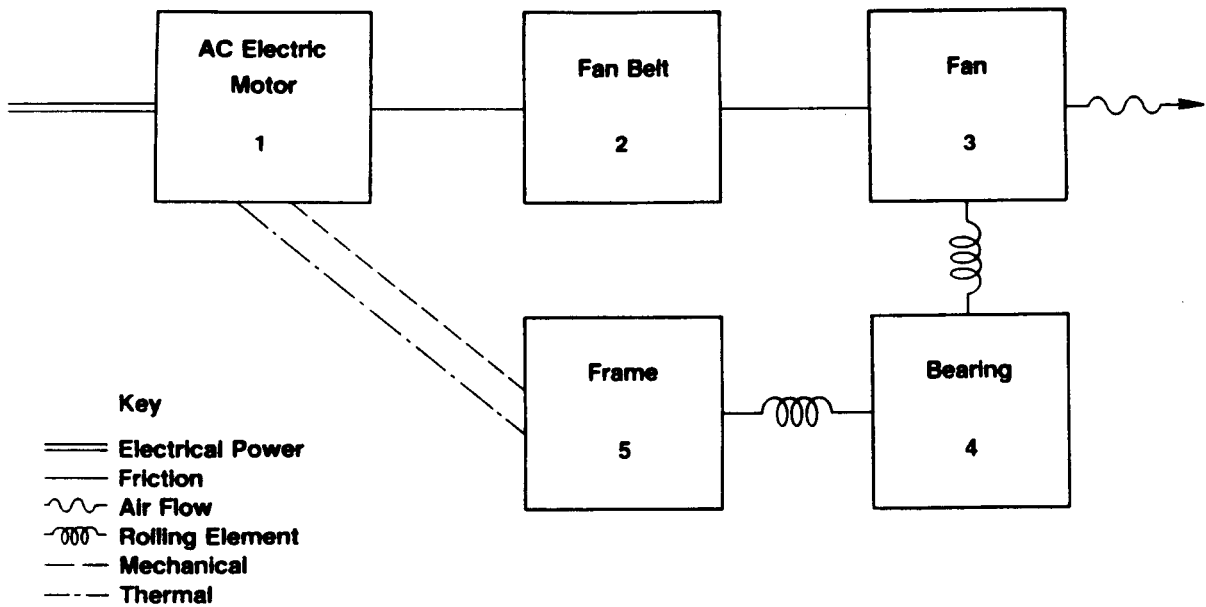

FIGURE 15. CONNECTIONS BETWEEN EXHAUST FAN MODULES

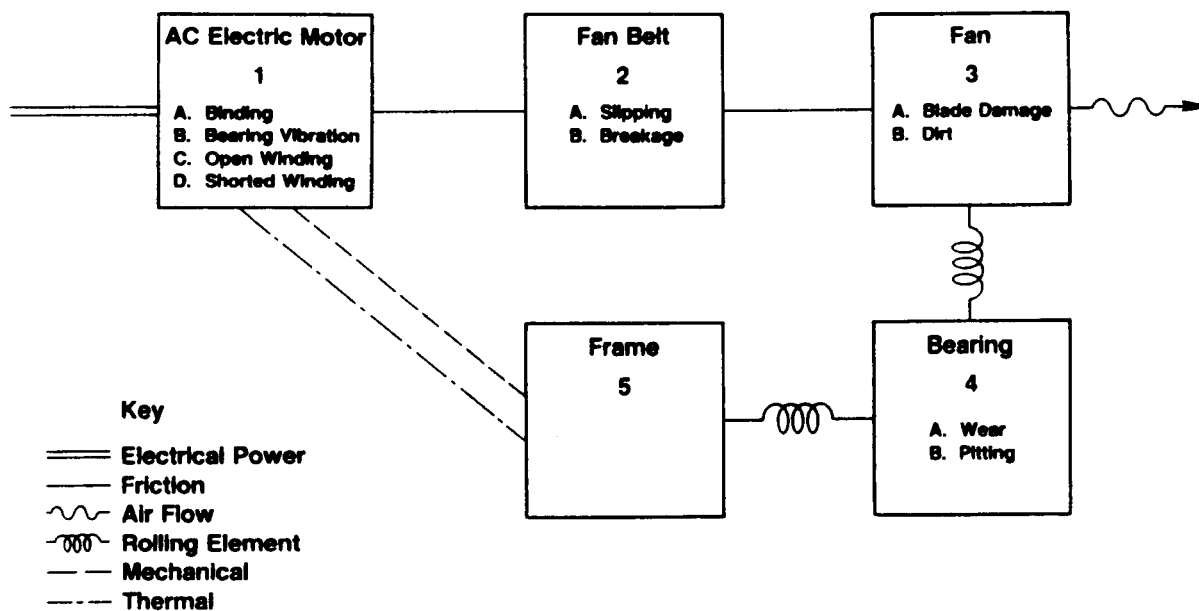

FIGURE 16. ADDITION OF FAILURE MODES TO EXHAUST FAN FIPM

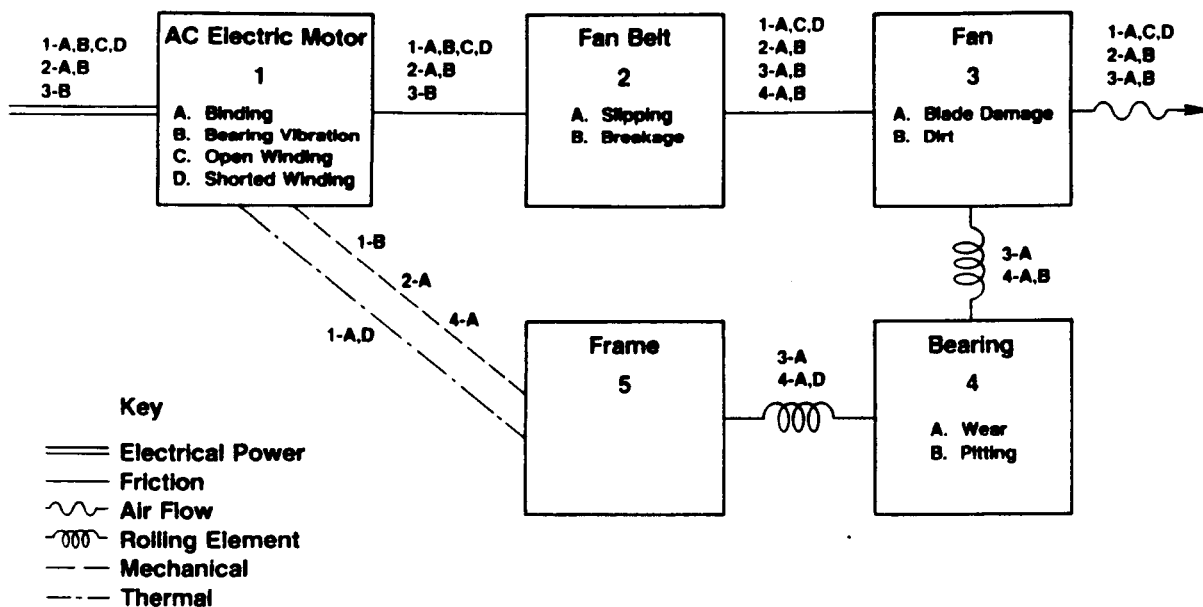

FIGURE 17. FAILURE INFORMATION ASSOCIATED WITH EXHAUST FAN CONNECTIONS

The failure information in the current example can be further categorized at each connection according to the type of measurement or sensor required for detection. An open winding [1C] or breakage of the fan belt [2B] could be detected by an ammeter on the electrical line. Similarly, binding of the motor [1A], a shorted winding [1D], or dirt on the fan [3B] can be detected by a voltmeter across the motor terminals. In Figure 18, the failure information for each connection has been grouped according to the type of measurement involved. This clustering of the failure information is the final step in the development of the FIPM. Analysis of the data in the model can now be initiated.

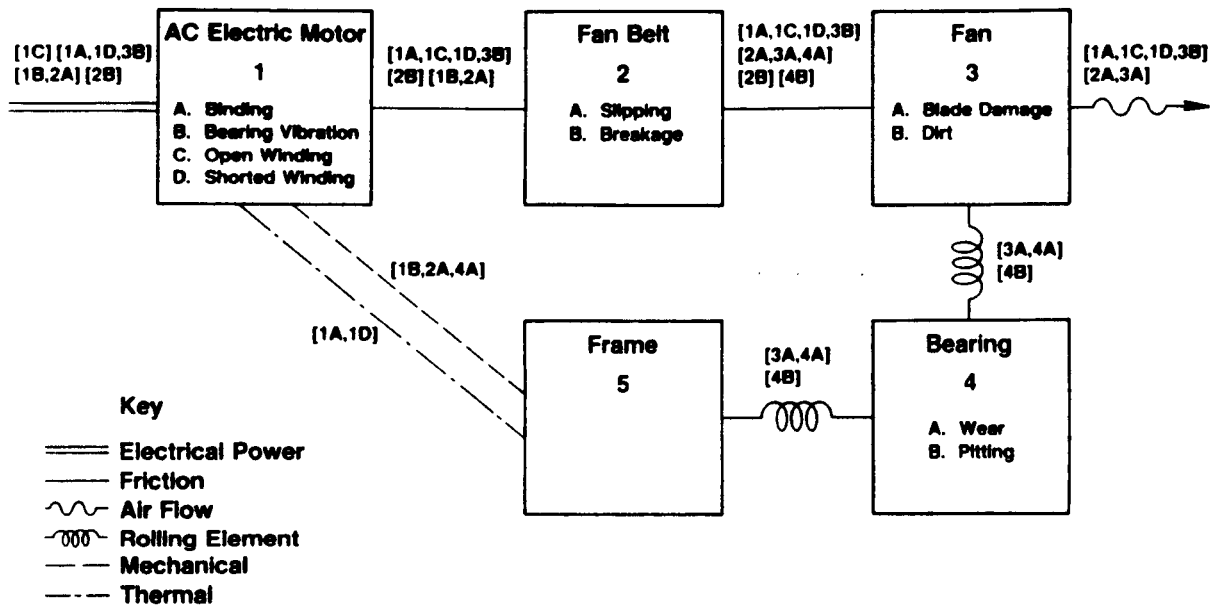

FIGURE 18. FAILURE INFORMATION GROUPED BY SIGNAL TYPE FOR THE EXHAUST FAN FIPM

A sensor of the appropriate type would detect any or all of the failure modes within a particular group. It would be necessary, therefore, to provide additional information or to further process the signal to uniquely identify any single failure mode. The process of determining the failure signatures and respective sensor sets is highly detailed and has not been undertaken for the exhaust fan example.

High-Pressure Oxidizer Turbopump FIPM

The high-pressure oxidizer turbopump (HPOTP) was selected as the initial SSME component for evaluation using the FIPM. An HPOTP FIPM was graphically constructed using the steps outlined in the preceding example. The resulting model was quite large due to the complex nature of the HPOTP. A large portion of the initial representation also was color coded for ease of interpretation. Due to both of these factors, the initial HPOTP FIPM is unsuitable for inclusion in this report. An attempt will, however, be made to describe the significant features of this model and the subsequent analysis which was performed. The version of the FIPM which will be described in this section is no longer the baseline configuration for the HPOTP. The reasons for this situation will be discussed. The revised FIPM approach which is currently being used is outlined in a subsequent subsection.

The original HPOTP FIPM had the following features:

- 46 modules
- 100 module failure modes
- 59 connections
- 2248 failure information propagations.

A small black and white excerpt of this FIPM is shown in Figure 19. A key for this graphic is included as Figure 20. All of the data comprising the FIPM was displayed on the graphic representation.

Subsequent to the development of the HPOTP FIPM, a preliminary analysis of the HPOTP failure information was performed using a failure information matrix. A portion of this matrix is shown in Figure 21. In this matrix, the rows represent connections (test points) between modules. The columns correspond to specific module failure modes. The data entered in the matrix at the intersection of a given row and column is the failure information types associated with the designated failure mode which can be detected at the designated connection. This matrix was used to develop a preliminary set of test signature equations for the HPOTP.

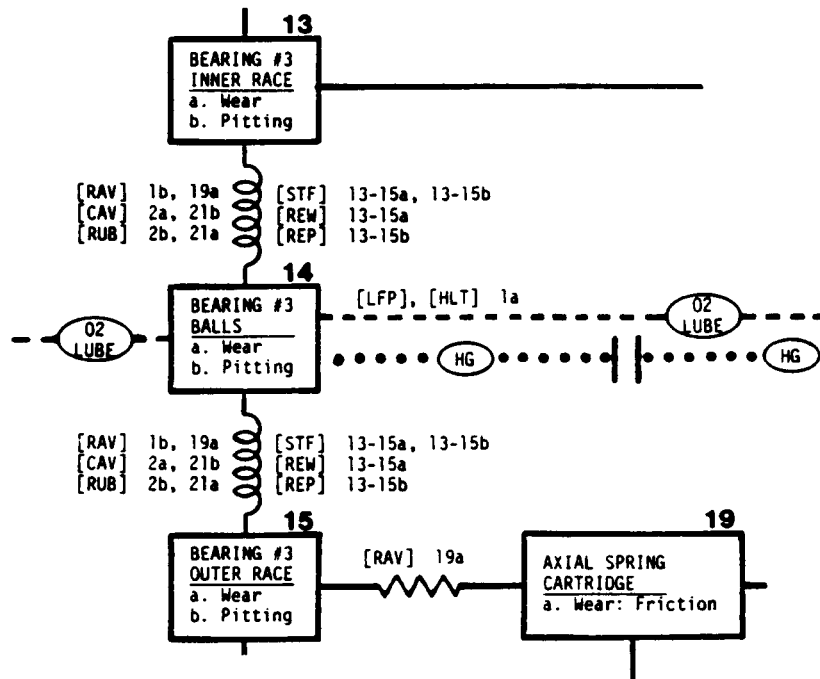

FIGURE 19. EXCERPT FROM INITIAL HPOTP FIPM

FAILURE SIGNAL TYPES

- [RUB] Rubbing
- [CAV] Cavitation
- [CRK] Cracking
- [REW] Rolling Element Wear
- [REP] Rolling Element Pitting
- [RAV] RPM Associated Vibration
- [IMP] Impact
- [LFP] Low Flow or Pressure
- [STF] Stress-time Fatigue Candidate
- [ERO] Erosion
- [HLT] High Local Temperature

COUPLING TYPE

- Solid
- - - - - Liquid
- Gas
- Liquid and Gas
- ~~~~~ Thermal

COUPLING MODIFIER

- (O2) Oxygen
- (HE) Helium
- (CP) Common Part
- |— Unanticipated Coupling
- ~~~~~ Spring
- Rolling Element
- (LUBE) Lubricant

FIGURE 20. KEY FOR INITIAL HPOTP FIPM

The test signatures were formulated by marching through the columns of the matrix. For each column, the rows were examined to determine where failure information resided. The rows also were scanned to identify other failure data present at the connection which exhibited the same signal characteristics (i.e., high temperature, low pressure, etc.). By careful evaluation of the matrix, it was possible to determine sets of signals which could be used to uniquely identify specific failures. Some examples of the initial results included:

- Failure mode 1B = rpm associated vibration @ test point 34 OR
= rpm associated vibration @ test point 36 OR
= rpm associated vibration @ test point 38
- Failure mode 2A = cavitation @ test point 5 AND NOT
cavitation @ test point 1
- Failure mode 2B OR
- Failure mode 3A OR
- Failure mode 5C = rubbing @ test point 4.

No attempt was made to determine a unique signature for certain classes of failure modes. In cases such as the turbopump bearings, it is not necessary to know which particular bearing is bad. An indication that any of the four bearings is experiencing degradation is sufficient cause to remove the turbopump from the engine and overhaul the bearings.

Subsequent efforts to specify a set of diagnostic sensors which would target all of the high-priority HPOTP failure modes, as identified in the SSME failure data review, encountered difficulty due to the need for additional data. The model, as constructed, did not have sufficient detail to adequately describe the failure signals. It was determined that specifying high temperature was insufficient without some sort of associated range. This initial application of the FIPM methodology to a complex mechanical system had also demonstrated the need for more formal definitions and standardized development rules. The definitions and development rules had previously been instituted on an ad hoc basis as the need arose. A decision was reached to restructure the HPOTP FIPM based on a more formal development methodology.

Current FIPM Methodology

The current FIPM methodology was developed by the originator of the FIPM concept with major inputs provided by the participants in the initial SSME FIPM activity. A number of FIPM development tools resulted from this process. These tools are included in Appendix A of this report. The allowable types of physical connections, failure modes, signals, and signal parameters are included for use in constructing an FIPM. These allowable values have been selected with respect to fundamental physical properties and laws. Their intent is to reduce the number of arbitrary and possibly confusing choices which must be made during model formulation. Rules regulating the handling of potentially ambiguous situations are also included. It was decided that the new FIPM procedure should be implemented in a data base format. This step was necessary to accommodate the large amounts of information which were projected for the SSME models.

The current FIPM methodology consists of two primary elements. These elements are:

- Simplified FIPM drawing
- FIPM data base.

The present FIPM drawing format summarizes key information about the system being modeled for use during generation and input of appropriate data base records. The data base stores all of the information associated with the FIPM including the items shown on the drawing. The data base, however, permits substantial amounts of additional descriptive and qualifying information to be stored and accessed.

FIPM Definitions

The following terms are used in reference to a failure information propagation model:

- SYSTEM - The top-level item or component which is being modeled (analyzed)
- MODULE - A subelement or function of the system

- CONNECTION - A path (mechanical, fluid, etc.) which exists between two modules
- FAILURE MODE - The physical mechanism or process by which a module ceases to perform its intended function
- FAILURE INFORMATION PROPAGATION - A description of specific signal characteristics associated with a given failure mode which can be detected at a particular connection.

FIPM Drawing

The first step in formulating a failure information propagation model is to develop a graphical representation or drawing of the system being analyzed. The principal function of the FIPM drawing is to describe the constituent modules of the system and to identify the connections between these modules. The initial drafts of the FIPM drawing are prepared by technical analysts or engineers familiar with the system involved. The number of modules included is chosen to be consistent with the overall level of detail required for the analysis. The accurate depiction of the system is critical to the overall development of the FIPM. This illustration is the foundation for the entire data base associated with a given system. Careful construction and review of the FIPM drawing minimizes potential corrections and changes to the data base.

The FIPM drawing is composed basically of boxes and lines which connect the boxes. Each box on the drawing represents a particular module. The lines represent the physical connections between the various modules. Additional information is also shown for both the boxes (modules) and the lines (connections) to further identify specific physical details associated with both of these elements. The format selected for the FIPM drawing allows all of the necessary data to be displayed in black and white for ease of reproduction. The key for the current FIPM drawings is shown in Figure 22.

An example of an FIPM module is shown in Figure 23. Each module on the FIPM drawing displays the following items of information:

- System code
- Module number

| <u>Connection</u> | <u>Connection Modifier</u> |
|----------------------------|----------------------------------|
| ———— Mechanical | ⊖ CP Common-Piece |
| ----- Liquid | ⊖ H ₂ Hydrogen |
| Gaseous | ⊖ O ₂ Oxygen |
| - - - - - Two-Phase | ⊖ HE Helium |
| | ⊖ HG Hot-Gas |
| | ⊖ RE Rolling-Element |
| | ⊥ Unanticipated |
| | [External |

FIGURE 22. KEY FOR CURRENT FIPM DRAWINGS

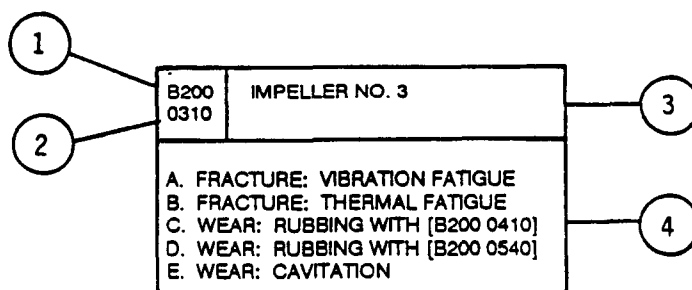

- 1 - SYSTEM
- 2 - MODULE NUMBER
- 3 - MODULE NAME
- 4 - MODULE FAILURE MODES

FIGURE 23. SAMPLE MODULE FROM AN FIPM DRAWING

- Module name
- Module failure modes.

For a given system, the module number and name must be unique.

An example of an FIPM connection is shown in Figure 24. Examination of the line type and symbols associated with specific connections enables the following items of information to be determined:

- General type of connection (solid, liquid, etc.)
- Additional data specifying exact type of connection
- Unanticipated connection
- Connection to external system.

Symbols may be combined as required to completely describe a particular connection.

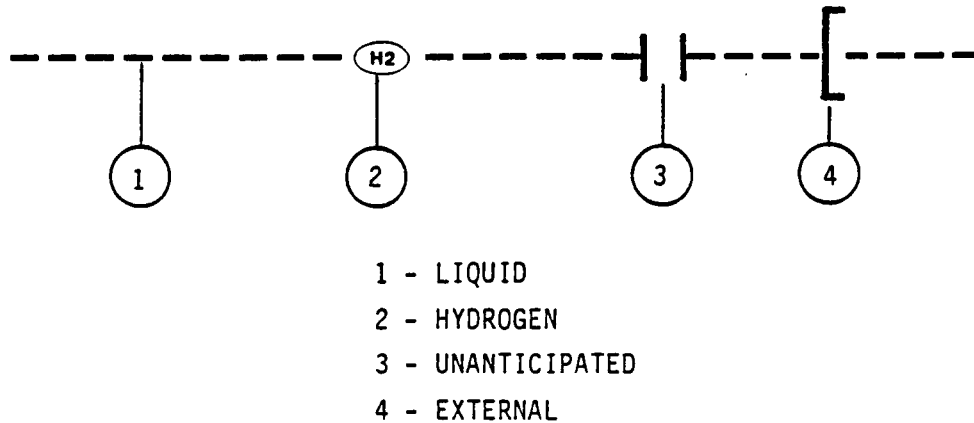

FIGURE 24. SAMPLE CONNECTION FROM AN FIPM DRAWING

FIPM Data Base

After completing the FIPM drawing, the next step is to generate and enter data into the failure information propagation model data base.

The current FIPM data base and software are discussed in detail in later sections of this report.

Space Shuttle Main Engine FIPMs

The initial approach to analyzing the SSME divides the engine into major components (systems) which are examined independently. This process reduces the size of the individual models to a manageable level and also eliminates the crossflow of failure information between systems. The idea behind the current method is to gain diagnostic insights relative to each high-priority item. This data subsequently will be used to make recommendations concerning monitoring requirements for a particular component.

The "SSME Failure Mode and Effects Analysis and Critical Items List" compiled by the Rocketdyne Division, Rockwell International Corporation (Reference 3) includes over 200 SSME components. Developing an individual FIPM for each of these items would not be the most efficient way to analyze the entire engine. Certain components, such as propellant ducts and pressurant lines, are relatively simple in nature. These systems can be easily modeled with just a few modules and connections. SSME items of this type are included as modules in the FIPM of the appropriate major component. For example, the high-pressure oxidizer duct is included with the HPOTP FIPM.

Each system (major component) is represented in the FIPM data base by a four-character code. These system designations coincide with the Rocketdyne FMEA item numbers (Reference 3, Table 2-1) whenever feasible. The record in the systems data file also indicates any additional Rocketdyne FMEA items which have been included in a particular FIPM system. Components which do not have a corresponding Rocketdyne FMEA number are given a similar four-character code. Confusion is avoided by selecting a number not used by Rocketdyne.

The generation of data for the HPOTP FIPM demonstrated that a very large number of failure information propagation records can be associated with a major SSME component such as the HPOTP. This observation resulted in the creation of separate failure information propagation data files for each major SSME component (system). There is

one data file each associated with the systems, modules, connections, failure modes, and references. Information of the appropriate nature is stored in each of these five files for all of the various FIPMs.

The FIPM methodology, as used for analyzing the SSME, includes special provisions for handling the connections between major engine components (FIPM systems). This feature of the technique allows the data flows between systems to be evaluated on a preliminary basis. It also enables the future expansion of the SSME model to a higher level through the combination of various system FIPMs.

(This page intentionally blank)

FIPM DATA BASE

The FIPM data base is a computerized system which stores all of the data necessary to create the various SSME failure information propagation models. The information contained in the FIPM data base is divided into the following six categories: systems, modules, connections, failure modes, failure information propagations, and references. Each of these categories corresponds to a major element of the overall FIPM process as discussed in the previous section. The data base was designed to store the essential FIPM information, additional descriptive data pertinent to each category and entries which document data base operations. Details on the structure and contents of the FIPM data base are included in the following subsections.

The FIPM data base has been implemented on a Digital Equipment Corporation (DEC) VAX computer. The data base management system selected was DEC's VAX Datatrieve. The computer and data base system were selected based on the availability of these items at both Battelle and NASA MSFC. The data base design and development activities were performed on the Battelle computers. After entry and verification at Battelle, the initial FIPM data files were transferred to NASA MSFC in February 1987.

Data Base Structure

The fundamental elements required to create a Datatrieve data base are records, domains, and data files. Records are the detailed descriptions of the data fields (information) which are stored. Domains are sets of data which share a common record definition. The data files are the actual VAX RMS (record management services) files which contain the information. Each of these elements must be defined at the Datatrieve command level before information can be stored. A domain is logically related to the corresponding record and data file through the domain definition. The definition for one of the FIPM domains (SYSTEMS) is shown in Figure 25. An excerpt from the corresponding record definition (SYSTEMS_REC) is displayed in Figure 26. The file definition command for this domain is illustrated in Figure 27.

```

      1      2
      |      |
DEFINE DOMAIN SYSTEMS USING SYSTEMS_REC ON
DEV$206:[BCDSSME2.DATA]SYSTEMS.DAT 3
; 4

```

- 1 - Domain name
- 2 - Record name
- 3 - Data file
- 4 - Definition terminator

FIGURE 25. DATATRIEVE DEFINE DOMAIN COMMAND

```

      1
      |
DEFINE RECORD SYSTEMS_REC USING
2  |
  |
  | 4 5
3  | 01 SYSTEMS_REC.
  |
  | 6 05 DATE_CREATED
  |
  | 7 [ USAGE IS DATE
  |   QUERY_NAME IS DCREATED
  |   EDIT_STRING IS X(23). 8
  |
  | 05 SYSTEM          PICTURE IS X(4)
  |                   QUERY_NAME IS SYS.
9  |
10 | ;

```

- 1 - Record name
- 2 - Comment line
- 3 - Group field
- 4 - Level number
- 5 - Field name
- 6 - Elementary field
- 7 - Field definition clauses
- 8 - Field definition terminator
- 9 - Additional field definitions
- 10 - Record definition terminator

FIGURE 26. DATATRIEVE DEFINE RECORD COMMAND

```

      ①
      |
DEFINE FILE FOR SYSTEMS KEY = DATE_CREATED
                        (DUP), ③
                        KEY = SYSTEM
                        KEY = SYSTEM_NAME
                        ] ④

```

- 1 - Domain name
- 2 - Field option to allow duplicate values
- 3 - Primary key clause
- 4 - Secondary key clauses

FIGURE 27. DATATRIEVE DEFINE FILE COMMAND

The FIPM data base is structured around six Datatrieve records. These include:

- SYSTEMS_REC
- MODULES_REC
- FAILUREMODES_REC
- CONNECTIONS_REC
- PROPAGATIONS_REC
- REFERENCES_REC.

Each of the records SYSTEMS_REC, MODULES_REC, FAILUREMODES_REC, CONNECTIONS_REC, and REFERENCES_REC is associated with two FIPM domains. PROPAGATIONS_REC is the basis for a group of domains which store SSME failure information propagation records. Table 4 lists all of the FIPM records, domains, and data files.

TABLE 4. FIPM RECORDS, DOMAINS, AND DATA FILES

| Record | Domain | Data File |
|------------------|--|--|
| SYSTEMS_REC | SYSTEMS SYSTEMS_FORM | DEV\$206:[BCDSSME2.DATA]SYSTEMS.DAT DEV\$206:[BCDSSME2.DATA]SYSTEMS_FORM.DAT |
| MODULES_REC | MODULES MODULES_FORM | DEV\$206:[BCDSSME2.DATA]MODULES.DAT DEV\$206:[BCDSSME2.DATA]MODULES_FORM.DAT |
| FAILUREMODES_REC | FAILUREMODES FAILUREMODES_FORM | DEV\$206:[BCDSSME2.DATA]FAILUREMODES.DAT DEV\$206:[BCDSSME2.DATA]FAILUREMODES_FORM.DAT |
| CONNECTIONS_REC | CONNECTIONS CONNECTIONS_FORM | DEV\$206:[BCDSSME2.DATA]CONNECTIONS.DAT DEV\$206:[BCDSSME2.DATA]CONNECTIONS_FORM.DAT |
| PROPAGATIONS_REC | PROPAGATIONS_A150 . . . | DEV\$206:[BCDSSME2.DATA]PROPAGATIONS_A150.DAT . . . |
| | PROPAGATIONS_Z910 PROPAGATIONS_FORM | DEV\$206:[BCDSSME2.DATA]PROPAGATIONS_Z910.DAT DEV\$206:[BCDSSME2.DATA]PROPAGATIONS_FORM.DAT |
| REFERENCES_REC | REFERENCES REFERENCES_FORM | DEV\$206:[BCDSSME2.DATA]REFERENCES.DAT DEV\$206:[BCDSSME2.DATA]REFERENCES_FORM.DAT |

The failure information propagations are not stored in a single domain (data file) due to the large number of data records involved. In the case of the HPOTP FIPM, there are 8213 failure information propagations. The access time for large files is a limiting factor on the overall size of the file. Experience with the HPOTP model indicated that a separate failure information propagation domain should be created for each SSME system (major component) being modeled. This format was adopted for the FIPM data base. As mentioned earlier, the same Datatrieve record definition is used for all of the propagations domains.

The data file associated with each FIPM domain is a VAX RMS indexed sequential file. These files contain an index of pointers based on the specified primary and secondary keys. The index allows the file access system to rapidly locate a record with specific attributes. This feature significantly improves the time required for many input and output operations. A primary key and at least one secondary key have been defined for all of the FIPM domains.

Data Description

The data formats established for the various FIPM domains are described in the following subsections. The data fields, query names, field type, data class, field length, and total record length are discussed for each of the Datatrieve domains. A query name is an abbreviated form of the field name which can be used during Datatrieve operations. The field type is group, elementary, or redefines. A group field contains one or more additional fields while an elementary field contains a single item of data. A redefines field creates an alternate definition for either a group or an elementary field without increasing the total length of the record. The field class describes the nature of the data contained in that field. Three field classes were used to define the six FIPM records: alphanumeric, numeric, and date. An alphanumeric field can contain any member of the Datatrieve character set (letter, digit, or special). A numeric field is restricted to digits plus an optional sign (+ or -). The date field is required for storing and manipulating dates in Datatrieve. The key fields which have been defined for the respective VAX RMS files are also identified.

Domains SYSTEMS and SYSTEMS_FORM

The domain SYSTEMS stores information which defines the top-level items or components (systems) being modeled. Each major engine component (high-pressure oxidizer turbopump, oxidizer preburner, etc.) has a corresponding FIPM system. A field has been provided for storing a descriptive name for each system. A total of 15 fields have been defined for identifying the Rocketdyne FMEA items which comprise each system. Fields also are included for specifying reference documents which were used in formulating each system model. Several additional fields are defined for storage of pertinent data relative to the creation and modification of each record. Domain SYSTEMS_FORM is used to display input/output forms on the computer terminal during data entry and modification. It is functionally identical to SYSTEMS but contains only one record.

The domain definitions for SYSTEMS and SYSTEMS_FORM are included in Reference 4, Appendix A. The corresponding record definition, SYSTEMS_REC, is contained in Reference 4, Appendix B. The major features associated with this record are summarized in Table 5. The Datatrieve file definition commands for both of these domains are included in Reference 4, Appendix C. The key fields for SYSTEMS and SYSTEMS_FORM are given in Table 6.

TABLE 5. SUMMARY OF FIPM RECORD SYSTEMS_REC

| Field | Query Name | Type | Class | Number of Digits or Characters | Length (bytes) |
|--------------|------------|------------|--------------|--------------------------------|----------------|
| SYSTEMS_REC | -- | Group | Alphanumeric | -- | 250 |
| DATE_CREATED | DCREATED | Elementary | Date | -- | 8 |
| SYSTEM | SYS | Elementary | Alphanumeric | 4 | 4 |
| SYSTEM_NAME | SYSNAME | Elementary | Alphanumeric | 80 | 80 |
| FMEA_ITEMS | -- | Group | Alphanumeric | -- | 60 |
| ITEM1 | -- | Elementary | Alphanumeric | 4 | 4 |
| ITEM2 | -- | Elementary | Alphanumeric | 4 | 4 |
| ITEM3 | -- | Elementary | Alphanumeric | 4 | 4 |
| ITEM4 | -- | Elementary | Alphanumeric | 4 | 4 |
| ITEM5 | -- | Elementary | Alphanumeric | 4 | 4 |
| ITEM6 | -- | Elementary | Alphanumeric | 4 | 4 |
| ITEM7 | -- | Elementary | Alphanumeric | 4 | 4 |
| ITEM8 | -- | Elementary | Alphanumeric | 4 | 4 |
| ITEM9 | -- | Elementary | Alphanumeric | 4 | 4 |
| ITEM10 | -- | Elementary | Alphanumeric | 4 | 4 |
| ITEM11 | -- | Elementary | Alphanumeric | 4 | 4 |
| ITEM12 | -- | Elementary | Alphanumeric | 4 | 4 |
| ITEM13 | -- | Elementary | Alphanumeric | 4 | 4 |
| ITEM14 | -- | Elementary | Alphanumeric | 4 | 4 |
| ITEM15 | -- | Elementary | Alphanumeric | 4 | 4 |

TABLE 5. SUMMARY OF FIPM RECORD SYSTEMS_REC (CONTINUED)

| Field | Query Name | Type | Class | Number of Digits or Characters | Length (bytes) |
|---------------------------|------------|------------|--------------|--------------------------------|----------------|
| REFERENCES | -- | Group | Alphanumeric | -- | 50 |
| REFERENCE1 | REF1 | Elementary | Alphanumeric | 5 | 5 |
| REFERENCE2 | REF2 | Elementary | Alphanumeric | 5 | 5 |
| REFERENCE3 | REF3 | Elementary | Alphanumeric | 5 | 5 |
| REFERENCE4 | REF4 | Elementary | Alphanumeric | 5 | 5 |
| REFERENCE5 | REF5 | Elementary | Alphanumeric | 5 | 5 |
| REFERENCE6 | REF6 | Elementary | Alphanumeric | 5 | 5 |
| REFERENCE7 | REF7 | Elementary | Alphanumeric | 5 | 5 |
| REFERENCE8 | REF8 | Elementary | Alphanumeric | 5 | 5 |
| REFERENCE9 | REF9 | Elementary | Alphanumeric | 5 | 5 |
| REFERENCE10 | REF10 | Elementary | Alphanumeric | 5 | 5 |
| PROPAGATIONS_FILE_CREATED | FIPCREATED | Elementary | Alphanumeric | 3 | 3 |
| DATE_LAST_MODIFIED | DLASTMOD | Elementary | Date | -- | 8 |
| MODIFYING_PROCEDURE | MODPROC | Elementary | Alphanumeric | 20 | 20 |
| FILLER | -- | Elementary | Alphanumeric | 17 | 17 |

TABLE 6. KEY FIELDS FOR DOMAINS SYSTEMS AND SYSTEMS_FORM

| Field | Key Type | Duplicate Values | Change Values |
|--------------|-----------|------------------|---------------|
| DATE_CREATED | Primary | Yes | No |
| SYSTEM | Alternate | Yes | Yes |
| SYSTEM_NAME | Alternate | Yes | Yes |

Domains MODULES and MODULES_FORM

The domain MODULES stores information which defines the subelements or functions comprising each of the systems (SSME components) being modeled. Each FIPM system has multiple modules which are identified by the combination of the system and a unique module number. Fields have been included for storing a descriptive name and the general function associated with each module. Several additional fields also are defined for storage of pertinent data relative to the creation and modification of each record. Domain MODULES_FORM is used to display input/output forms on the computer terminal during data entry and modification. It is functionally identical to MODULES but contains only one record.

The domain definitions for MODULES and MODULES_FORM are included in Reference 4, Appendix A. The corresponding record definition, MODULES_REC, is contained in Reference 4, Appendix B. The major features associated with this record are summarized in Table 7. The Datatrieve file definition commands for both of these domains are included in Reference 4, Appendix C. The key fields for MODULES and MODULES_FORM are given in Table 8.

TABLE 7. SUMMARY OF FIPM RECORD MODULES_REC

| Field | Query Name | Type | Class | Number of Digits or Characters | Length (bytes) |
|------------------------|------------|------------|--------------|--------------------------------|----------------|
| MODULES_REC | -- | Group | Alphanumeric | -- | 406 |
| DATE_CREATED | DCREATED | Elementary | Date | -- | 8 |
| SYSTEM_MODULE | SYSMOD | Elementary | Alphanumeric | 8 | 8 |
| SYSTEM_MODULE_PARTS | -- | Redefines | -- | -- | -- |
| SYSTEM_MODULE | SYS MOD | Elementary | Alphanumeric | 4 | 4 |
| SYSTEM_MODULE_NAME | MOD | Elementary | Numeric | 4 | 4 |
| SYSTEM_MODULE_FUNCTION | SYSMODNAME | Elementary | Alphanumeric | 80 | 80 |
| DATE_LAST_MODIFIED | SYSMODFUNC | Elementary | Alphanumeric | 242 | 242 |
| MODIFYING_PROCEDURE | DLASTMOD | Elementary | Date | -- | 8 |
| FILLER | MODPROC | Elementary | Alphanumeric | 20 | 20 |
| | -- | Elementary | Alphanumeric | 40 | 40 |

TABLE 8. KEY FIELDS FOR DOMAINS MODULES AND MODULES_FORM

| Field | Key Type | Duplicate Values | Change Values |
|--------------------|-----------|------------------|---------------|
| DATE_CREATED | Primary | Yes | No |
| SYSTEM_MODULE | Alternate | Yes | Yes |
| SYSTEM_MODULE_NAME | Alternate | Yes | Yes |

Domains FAILUREMODES and FAILUREMODES_FORM

The domain FAILUREMODES stores information which defines the failure modes identified for each module. The individual modules, in general, will have multiple failure modes. The principal field for each record is a 20-character code which specifies the source module, the failure mechanism, and any accomplice module which may be involved. Fields are provided for the entry of text which describes the failure mode and identifies the general effects associated with it. Several additional fields also are defined for storage of pertinent data relative to the creation and modification of each record. Domain FAILUREMODES_FORM is used to display input/output forms on the computer terminal during data entry and modification. It is functionally identical to FAILUREMODES but contains only one record.

The domain definitions for FAILUREMODES and FAILUREMODES_FORM are included in Reference 4, Appendix A. The corresponding record definition, FAILUREMODES_REC, is contained in Reference 4, Appendix B. The major features associated with this record are summarized in Table 9. The Datatrieve file definition commands for both of these domains are included in Reference 4, Appendix C. The key fields for FAILUREMODES and FAILUREMODES_FORM are given in Table 10.

TABLE 9. SUMMARY OF FIPM RECORD FAILUREMODES_REC

| Field | Query Name | Type | Class | Number of Digits or Characters | Length (bytes) |
|--------------------------------|------------|------------|--------------|--------------------------------|----------------|
| FAILUREMODES_REC | -- | Group | Alphanumeric | -- | 1364 |
| DATE_CREATED | DCREATED | Elementary | Date | -- | 8 |
| FMCODE | -- | Elementary | Alphanumeric | 20 | 20 |
| FMCODE_PARTS | -- | Redefines | -- | -- | -- |
| SOURCE_SYSTEM_MODULE | SSYSMOD | Elementary | Alphanumeric | 8 | 8 |
| SOURCE_SYSTEM_MODULE_PARTS | -- | Redefines | -- | -- | -- |
| SOURCE_SYSTEM | SSYS | Elementary | Alphanumeric | 4 | 4 |
| SOURCE_MODULE | SMOD | Elementary | Numeric | 4 | 4 |
| FAILURE_MODE_SUBMODE | FMSUBM | Elementary | Alphanumeric | 4 | 4 |
| FAILURE_MODE_SUBMODE_PARTS | -- | Redefines | -- | -- | -- |
| FAILURE_MODE | FM | Elementary | Alphanumeric | 2 | 2 |
| FAILURE_SUBMODE | FSUBM | Elementary | Alphanumeric | 2 | 2 |
| ACCOMPLICE_SYSTEM_MODULE | ACCSYSMOD | Elementary | Alphanumeric | 8 | 8 |
| ACCOMPLICE_SYSTEM_MODULE_PARTS | -- | Redefines | -- | -- | -- |
| ACCOMPLICE_SYSTEM | ACCSYS | Elementary | Alphanumeric | 4 | 4 |
| ACCOMPLICE_MODULE | ACCMOD | Elementary | Numeric | 4 | 4 |
| DESCRIPTION | DESC | Elementary | Alphanumeric | 242 | 242 |
| EFFECTS | -- | Group | Alphanumeric | -- | 966 |
| EFFECT1 | -- | Elementary | Alphanumeric | 161 | 161 |
| EFFECT2 | -- | Elementary | Alphanumeric | 161 | 161 |
| EFFECT3 | -- | Elementary | Alphanumeric | 161 | 161 |
| EFFECT4 | -- | Elementary | Alphanumeric | 161 | 161 |
| EFFECT5 | -- | Elementary | Alphanumeric | 161 | 161 |
| EFFECT6 | -- | Elementary | Alphanumeric | 161 | 161 |
| DATE_LAST_MODIFIED | DLASTMOD | Elementary | Date | -- | 8 |
| MODIFYING_PROCEDURE | MODPROC | Elementary | Alphanumeric | 20 | 20 |
| FILLER | -- | Elementary | Alphanumeric | 30 | 100 |

TABLE 10. KEY FIELDS FOR DOMAINS FAILUREMODES
AND FAILUREMODES_FORM

| Field | Key Type | Duplicate Values | Change Values |
|--------------|-----------|------------------|---------------|
| DATE_CREATED | Primary | Yes | No |
| FMCODE | Alternate | Yes | Yes |

Domains CONNECTIONS and CONNECTIONS_FORM

The domain CONNECTIONS stores information which defines the physical paths which exist between modules. In general, each module will have multiple connections to the adjacent module(s). The principal field in each record is a 21-character code which specifies the two modules being connected and the exact nature of the connection. Several additional fields also are defined for storage of pertinent data relative to the creation and modification of each record. Domain CONNECTIONS_FORM is used to display input/output forms on the computer terminal during data entry and modification. It is functionally identical to CONNECTIONS but contains only one record.

The domain definitions for CONNECTIONS and CONNECTIONS_FORM are included in Reference 4, Appendix A. The corresponding record definition, CONNECTIONS_REC, is contained in Reference 4, Appendix B. The major features associated with this record are summarized in Table 11. The Datatrieve file definition commands for both of these domains are included in Reference 4, Appendix C. The key fields for CONNECTIONS and CONNECTIONS_FORM are given in Table 12.

TABLE 11. SUMMARY OF FIPM RECORD CONNECTIONS_REC

| Field | Query Name | Type | Class | Number of Digits or Characters | Length (bytes) |
|--------------------------|------------|------------|--------------|--------------------------------|----------------|
| CONNECTIONS_REC | -- | Group | Alphanumeric | -- | 77 |
| DATE_CREATED | DCREATED | Elementary | Date | -- | 8 |
| CODE_NUMBER | CODENO | Elementary | Alphanumeric | 21 | 21 |
| CODE_NUMBER_PARTS | -- | ReDefines | -- | -- | -- |
| SYSTEM_MODULE_A | SYSMODA | Elementary | Alphanumeric | 8 | 8 |
| SYSTEM_MODULE_A_PARTS | -- | ReDefines | -- | -- | -- |
| SYSTEM_A | SYSA | Elementary | Alphanumeric | 4 | 4 |
| MODULE_A | MODA | Elementary | Numeric | 4 | 4 |
| CONNECTION | CN | Elementary | Alphanumeric | 4 | 4 |
| CONNECTION_PARTS | -- | ReDefines | -- | -- | -- |
| CONNECTION_TYPE | CNTYPE | Elementary | Alphanumeric | 2 | 2 |
| CONNECTION_QUALIFIER | CNQUAL | Elementary | Alphanumeric | 2 | 2 |
| UNANTICIPATED_CONNECTION | UA | Elementary | Alphanumeric | 1 | 1 |
| SYSTEM_MODULE_B | SYSMODB | Elementary | Alphanumeric | 8 | 8 |
| SYSTEM_MODULE_B_PARTS | -- | ReDefines | -- | -- | -- |
| SYSTEM_B | SYSB | Elementary | Alphanumeric | 4 | 4 |
| MODULE_B | MOBB | Elementary | Numeric | 4 | 4 |
| DATE_LAST_MODIFIED | DLASTMOD | Elementary | Date | -- | 8 |
| MODIFYING_PROCEDURE | MODPROC | Elementary | Alphanumeric | 20 | 20 |
| FILLER | -- | Elementary | Alphanumeric | 30 | 20 |

TABLE 12. KEY FIELDS FOR DOMAINS CONNECTIONS AND CONNECTIONS_FORM

| Field | Key Type | Duplicate Values | Change Values |
|--------------|-----------|------------------|---------------|
| DATE_CREATED | Primary | Yes | No |
| CODE_NUMBER | Alternate | Yes | Yes |

Domains PROPAGATIONS_A150 through PROPAGATIONS_Z910 and PROPAGATIONS_FORM

The domains PROPAGATIONS_A150 through PROPAGATIONS_Z910 store the actual failure information propagation data. Each of the items in domain SYSTEMS has a separate propagations domain. One of the fields identifies the module failure mode which initiated the information flow. Another field specifies the particular connection to which the data has passed. Most of the fields describe the specific characteristics of the failure signal. Three text fields have been included for entry of comments pertaining to the failure information propagation. Three fields also are defined for storage of data concerning the creation and modification of each record. Domain PROPAGATIONS_FORM is used to display input/output forms on the computer terminal. It is functionally identical to the other propagations domains but contains only one record.

The domain definitions for all of the current failure information propagations domains are included in Reference 4, Appendix A. The corresponding record definition, PROPAGATIONS_REC, is contained in Reference 4, Appendix B. The major features associated with this record are summarized in Table 13. The Datatrieve file definition commands for all of the domains are included in Reference 4, Appendix C. The key fields for PROPAGATIONS_A150 through PROPAGATIONS_Z910 and PROPAGATIONS_FORM are given in Table 14.

TABLE 13. SUMMARY OF FIPM RECORD PROPAGATIONS_REC

| Field | Query Name | Type | Class | Number of Digits or Characters | Length (bytes) |
|--------------------------------|------------|------------|--------------|--------------------------------|----------------|
| PROPAGATIONS_REC | -- | Group | Alphanumeric | -- | 473 |
| DATE_CREATED | DCREATED | Elementary | Date | -- | 8 |
| FMCODE | -- | Elementary | Alphanumeric | 20 | 20 |
| FMCODE_PARTS | -- | Redefines | Alphanumeric | -- | 8 |
| SOURCE_SYSTEM_MODULE | SSYSMOD | Elementary | Alphanumeric | 8 | -- |
| SOURCE_SYSTEM_MODULE_PARTS | -- | Redefines | Alphanumeric | -- | 4 |
| SOURCE_SYSTEM | SSYS | Elementary | Alphanumeric | 4 | 4 |
| SOURCE_MODULE | SMOD | Elementary | Numeric | 4 | 4 |
| FAILURE_MODE_SUBMODE | FMSUBM | Elementary | Alphanumeric | 4 | 4 |
| FAILURE_MODE_SUBMODE_PARTS | -- | Redefines | Alphanumeric | -- | 2 |
| FAILURE_MODE | FM | Elementary | Alphanumeric | 2 | 2 |
| FAILURE_SUBMODE | FSUBM | Elementary | Alphanumeric | 2 | 2 |
| ACCOMPLICE_SYSTEM_MODULE | ACCSYSMOD | Elementary | Alphanumeric | 8 | 8 |
| ACCOMPLICE_SYSTEM_MODULE_PARTS | -- | Redefines | Alphanumeric | -- | 4 |
| ACCOMPLICE_SYSTEM | ACCSYS | Elementary | Alphanumeric | 4 | 4 |
| ACCOMPLICE_MODULE | ACCMOD | Elementary | Numeric | 4 | 4 |
| CODE_NUMBER | CODENO | Elementary | Alphanumeric | 21 | 21 |
| CODE_NUMBER_PARTS | -- | Redefines | Alphanumeric | -- | 8 |
| SYSTEM_MODULE_A | SYSMODA | Elementary | Alphanumeric | 8 | 8 |
| SYSTEM_MODULE_A_PARTS | -- | Redefines | Alphanumeric | -- | 4 |
| SYSTEM_A | SYSA | Elementary | Alphanumeric | 4 | 4 |
| MODULE_A | MODA | Elementary | Numeric | 4 | 4 |
| CONNECTION | CN | Elementary | Alphanumeric | 4 | 4 |
| CONNECTION_PARTS | -- | Redefines | Alphanumeric | -- | 2 |
| CONNECTION_TYPE | CNTYPE | Elementary | Alphanumeric | 2 | 2 |
| CONNECTION_QUALIFIER | CNQUAL | Elementary | Alphanumeric | 2 | 2 |
| UNANTICIPATED_CONNECTION | UA | Elementary | Alphanumeric | 1 | 1 |
| SYSTEM_MODULE_B | SYSMODB | Elementary | Alphanumeric | 8 | 8 |
| SYSTEM_MODULE_B_PARTS | -- | Redefines | Alphanumeric | -- | 4 |
| SYSTEM_B | SYSB | Elementary | Alphanumeric | 4 | 4 |
| MODULE_B | MODB | Elementary | Numeric | 4 | 4 |

TABLE 13. SUMMARY OF FIPM RECORD PROPAGATIONS_REC (CONTINUED)

| Field | Query Name | Type | Class | Number of Digits or Characters | Length (bytes) |
|---------------------|------------|------------|--------------|--------------------------------|----------------|
| SIGNAL DESCRIPTION | -- | Group | Alphanumeric | -- | 366 |
| RAW SIGNAL | -- | Group | Alphanumeric | -- | 76 |
| SIGNAL TYPE | SIG | Elementary | Alphanumeric | 20 | 20 |
| SIGNAL UNITS | SIGUNIT | Elementary | Alphanumeric | 25 | 25 |
| DIMENSIONS | DIM | Elementary | Numeric | 1 | 1 |
| SIGNAL QUALITY | SIGQUAL | Elementary | Numeric | 1 | 1 |
| FREQUENCY_TIME | -- | Group | Alphanumeric | -- | 29 |
| MAX_FREQ_OR_TIME | MAXFT | Elementary | Numeric | 2 | 2 |
| MIN_FREQ_OR_TIME | MINFT | Elementary | Numeric | 2 | 2 |
| FT_UNITS | FTUNIT | Elementary | Alphanumeric | 25 | 25 |
| SYMPTOM_ELEMENT | -- | Group | Alphanumeric | -- | 50 |
| SENSITIVE_PARAMETER | -- | Group | Alphanumeric | -- | 45 |
| PARAMETER | PAR | Elementary | Alphanumeric | 20 | 20 |
| PARAMETER_UNITS | PARUNIT | Elementary | Alphanumeric | 25 | 25 |
| SYMPTOM_DURATION | SYMDUR | Elementary | Numeric | 2 | 2 |
| PERIOD_OF_ONSET | ONSET | Elementary | Numeric | 2 | 2 |
| INDICATES_FAILURE | INDFAIL | Elementary | Alphanumeric | 1 | 1 |
| COMMENTS | -- | Group | Alphanumeric | -- | 240 |
| COMMENT1 | -- | Elementary | Alphanumeric | 80 | 80 |
| COMMENT2 | -- | Elementary | Alphanumeric | 80 | 80 |
| COMMENT3 | -- | Elementary | Alphanumeric | 80 | 80 |
| DATE_LAST_MODIFIED | DIASIMOD | Elementary | Date | -- | 8 |
| MODIFYING_PROCEDURE | MODPROC | Elementary | Alphanumeric | 20 | 20 |
| FILLER | -- | Elementary | Alphanumeric | 30 | 30 |

TABLE 14. KEY FIELDS FOR DOMAINS PROPAGATIONS_A150 THROUGH PROPAGATIONS_Z910 AND PROPAGATIONS_FORM

| Field | Key Type | Duplicate Values | Change Values |
|--------------|-----------|------------------|---------------|
| DATE_CREATED | Primary | Yes | No |
| FMCODE | Alternate | Yes | Yes |
| CODE_NUMBER | Alternate | Yes | Yes |
| SIGNAL_TYPE | Alternate | Yes | Yes |

The domain and file definition commands for PROPAGATIONS_A150 through PROPAGATIONS_Z910 differ from those used for the other FIPM domains. The domain and file definition commands associated with PROPAGATIONS_A150 are shown respectively in Figures 28 and 29. The domain definition uses the Datatrieve logicals PROPAGATIONS and PROPAGATIONS_FILE while the file definition uses the logical PROPAGATIONS. This process was selected to allow automated definition of a failure information propagation domain and file for each new entry in domain SYSTEMS.

```

FN$CREATE_LOG("PROPAGATIONS", "PROPAGATIONS_A150")
FN$CREATE_LOG("PROPAGATIONS_FILE",
  "DEV$206:[BCDSSME2.DATA]PROPAGATIONS_A150.DAT")
DEFINE DOMAIN PROPAGATIONS USING PROPAGATIONS_REC ON PROPAGATIONS_FILE
;

```

FIGURE 28. DOMAIN DEFINITION COMMANDS FOR PROPAGATIONS_A150

```

FN$CREATE_LOG("PROPAGATIONS", "PROPAGATIONS_A150")
DEFINE FILE FOR PROPAGATIONS KEY = DATE_CREATED (DUP),
                                KEY = FMCODE      (DUP),
                                KEY = CODE_NUMBER (DUP),
                                KEY = SIGNAL_TYPE  (DUP)

```

FIGURE 29. FILE DEFINITION COMMANDS FOR PROPAGATIONS_A150

Domains REFERENCES and REFERENCES_FORM

The domain REFERENCES stores information on the various documents used during the formulation of the FIPMs. The fields in this record provide for the input of standard bibliographical information such as author(s), title, company, company document number, data, and contract number. Another field stores a unique reference number for the document which is assigned by the Datatrieve input procedure. Several additional fields also are defined for storage of pertinent data relative to the creation and modification of each record. Domain REFERENCES_FORM is used to display input/output forms on the computer terminal during data entry and modification. It is functionally identical to REFERENCES but contains only one record.

The domain definitions for REFERENCES and REFERENCES_FORM are included in Reference 4, Appendix A. The corresponding record definition, REFERENCES_REC, is contained in Reference 4, Appendix B. The major features associated with this record are summarized in Table 15. The Datatrieve file definition commands for both of these domains are included in Reference 4, Appendix C. The key fields for REFERENCES and REFERENCES_FORM are given in Table 16.

TABLE 15. SUMMARY OF FIPM RECORD REFERENCES_REC

| field | Query Name | Type | Class | Number of Digits or Characters | Length (bytes) |
|------------------------|------------|------------|--------------|--------------------------------|----------------|
| REFERENCES_REC | -- | Group | Alphanumeric | -- | 433 |
| DATE_CREATED | DCREATED | Elementary | Date | -- | 8 |
| REFERENCE_NUMBER | REFNO | Elementary | Alphanumeric | 5 | 5 |
| REFERENCE_NUMBER_PARTS | -- | Redefines | -- | -- | -- |
| SOURCE_ABBREVIATION | SABBREV | Elementary | Alphanumeric | 2 | 2 |
| SEQUENCE_NUMBER | SEQNO | Elementary | Numeric | 3 | 3 |
| AUTHORS | -- | Group | Alphanumeric | -- | 100 |
| AUTHOR1 | -- | Elementary | Alphanumeric | 25 | 25 |
| AUTHOR2 | -- | Elementary | Alphanumeric | 25 | 25 |
| AUTHOR3 | -- | Elementary | Alphanumeric | 25 | 25 |
| AUTHOR4 | -- | Elementary | Alphanumeric | 25 | 25 |
| DOCUMENT_TITLE | TITLE | Elementary | Alphanumeric | 161 | 161 |
| DOCUMENT_SOURCE | SOURCE | Elementary | Alphanumeric | 30 | 30 |
| DOCUMENT_NUMBER | DOCNO | Elementary | Alphanumeric | 30 | 30 |
| DOCUMENT_DATE | DOCDATE | Elementary | Alphanumeric | 11 | 11 |
| CONTRACT_NUMBER | CONTNO | Elementary | Alphanumeric | 20 | 20 |
| DATE_LAST_MODIFIED | DLASTMOD | Elementary | Date | -- | 8 |
| MODIFYING_PROCEDURE | MODPROC | Elementary | Alphanumeric | 20 | 20 |
| FILLER | -- | Elementary | Alphanumeric | 40 | 40 |

TABLE 16. KEY FIELDS FOR DOMAINS REFERENCES AND REFERENCES_FORM

| Field | Key Type | Duplicate Values | Change Values |
|------------------|-----------|------------------|---------------|
| DATE_CREATED | Primary | Yes | No |
| REFERENCE_NUMBER | Alternate | Yes | Yes |
| DOCUMENT_TITLE | Alternate | Yes | Yes |
| DOCUMENT_SOURCE | Alternate | Yes | Yes |

(This page intentionally blank)

FIPM DATA BASE SOFTWARE

The FIPM data base development software provides a controlled, interactive environment in which failure information propagation data can be stored, modified, and listed. The software allows the user to perform a number of predefined data base operations. Direct access to the data base is restricted to prevent inadvertent changes which can invalidate large portions of the data files. The software also performs an extensive number of validation tests on the information entered by the user during the storage and modification of FIPM records. The data base software was developed using the following three Digital Equipment Corporation (DEC) software packages:

- VAX/VMS Digital Command Language (DCL)
- Datatrieve
- Terminal Data Management System (TDMS).

DCL command procedures provide the overall control of the FIPM software through a series of four menus. VAX command files containing Datatrieve instructions are used in conjunction with the menus to initiate the storage, modification, or listing of FIPM information. The actual manipulation of the FIPM records is accomplished using Datatrieve procedures and tables. Terminal forms created using TDMS utilities provide the interactive user interface. The DCL, Datatrieve, and TDMS software elements are outlined in the following subsections.

Digital Command Language Procedures

The Digital Command Language enables the user to instruct the VAX/VMS operating system to perform various operations. DCL command procedures are files which contain a series of DCL commands. When a command procedure is executed, the computer processes all of the commands contained in the file and then returns to the point of origin. DCL command procedures are used in the FIPM data base to provide the top-level control of the software elements.

When a user initiates a VAX computer session, the operating system searches the default file directory for a file named LOGIN.COM. If the file is found, the computer executes the DCL commands in LOGIN.COM before performing any other operations. The FIPM data base development software uses this intrinsic VAX process to direct the program flow into a carefully controlled environment. The user is channeled from one procedure to the next without going to the DCL command level. Provisions are incorporated for users with special access privileges to bypass these procedures and execute commands at the DCL level.

The LOGIN.COM file created for the FIPM data base pauses for a response from the terminal. If the user enters the correct access code, the procedure will prompt for PASSWORD 1 and then PASSWORD 2. The procedure exits to the DCL command level if the access code and both passwords are entered correctly. If either PASSWORD 1 or PASSWORD 2 is not valid, the procedure loops back to the point of the initial pause. All responses except for the correct access code will result in the computer executing the DCL procedure FIPM_MENU.COM. FIPM_MENU.COM displays the main FIPM menu to the user. This menu is shown in Figure 30. The program flow is directed to either FIPM_STORE.COM, FIPM_MODIFY.COM, or FIPM_LIST.COM depending on the line number selected (1, 2, or 3 respectively). The user can also terminate the current computer session by entering line number 4. It is possible to exit to the DCL command level from the main menu by entering the correct access code and passwords. The top-level FIPM software flow is depicted in Figure 31. Listings of the DCL procedures LOGIN.COM and FIPM_MENU.COM are included in Reference 4, Appendix D.

 FAILURE INFORMATION PROPAGATION MODEL

MAIN MENU

1. Store FIPM Data
2. Modify FIPM Data
3. List FIPM Data
4. Exit Procedure and Logout

Please enter LINE NUMBER:

FIGURE 30. MENU FOR CONTROLLED ACCESS TO FIPM DATA BASE

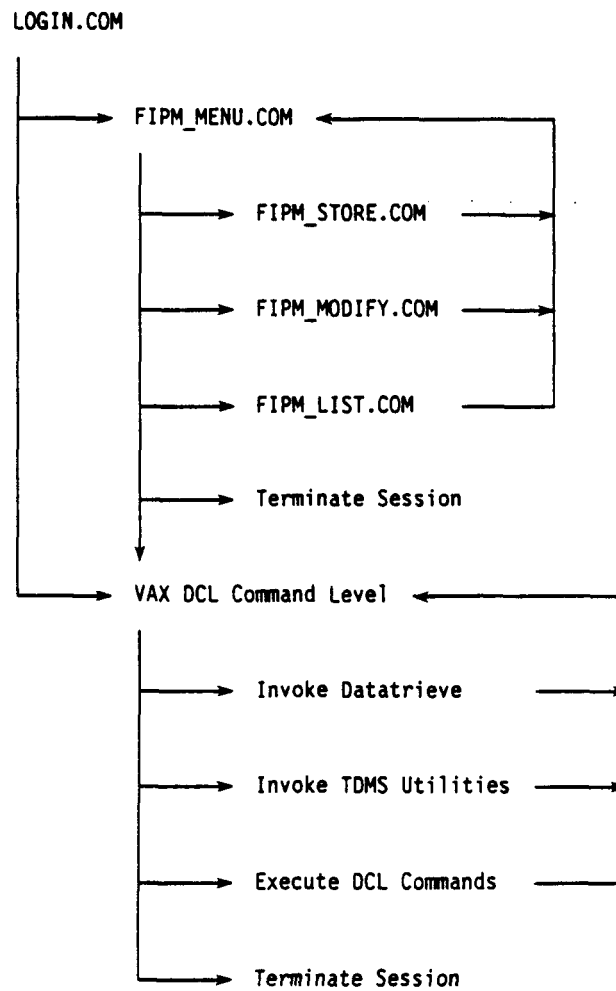

FIGURE 31. TOP-LEVEL FIPM SOFTWARE FLOWS

If the user selects the store FIPM data option, the DCL procedure FIPM_STORE.COM is called to display the menu shown in Figure 32. A response of 1 through 6 will result in the execution of the Datatrieve command file STORE_REF.COM, STORE_SYS.COM, STORE_MOD.COM, STORE_FM.COM, STORE_CON.COM, or STORE_FIP.COM respectively. After executing the appropriate Datatrieve command file, the procedure FIPM_STORE.COM redisplay the store menu. The user may elect to continue storing data in any of the displayed domains or may return to the main menu procedure by selecting line number 7. The program flow for storing FIPM data is shown in Figure 33. A listing of the DCL command procedure FIPM_STORE.COM is included in Reference 4, Appendix D.

If the user selects the modify FIPM data option, the DCL procedure FIPM_MODIFY.COM is called to display the menu shown in Figure 34. A response of 1 through 5 will result in the execution of the Datatrieve command file MODIFY_REF.COM, MODIFY_SYS.COM, MODIFY_MOD.COM, MODIFY_FM.COM, or MODIFY_FIP.COM respectively. The records in domain CONNECTIONS cannot be modified from this menu. After executing the appropriate Datatrieve command file, the procedure FIPM_MODIFY.COM redisplay the modify menu. The user may elect to continue modifying data in any of the displayed domains or may return to the main menu procedure by selecting line number 6. The program flow for modifying FIPM data is shown in Figure 35. A listing of the DCL command procedure FIPM_MODIFY.COM is included in Reference 4, Appendix D.

 FAILURE INFORMATION PROPAGATION MODEL

STORE MENU

- 1. Domain REFERENCES
- 2. Domain SYSTEMS
- 3. Domain MODULES
- 4. Domain FAILUREMODES
- 5. Domain CONNECTIONS
- 6. Domain PROPAGATIONS
- 7. Exit to MAIN MENU

Please enter LINE NUMBER:

FIGURE 32. MENU FOR STORING FIPM DATA BASE RECORDS

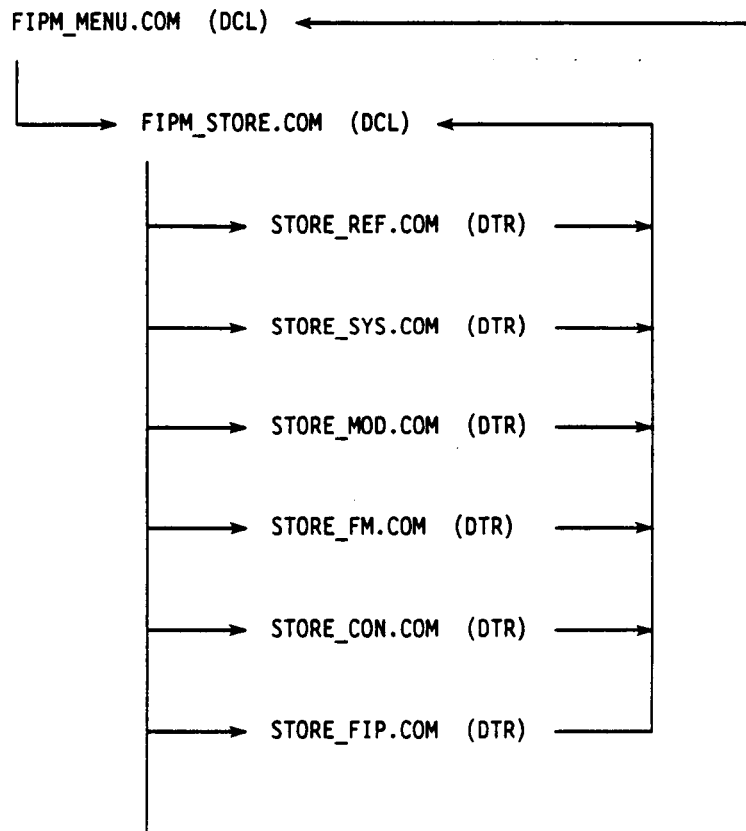

FIGURE 33. PROGRAM FLOW FOR STORING FIPM DATA

=====

FAILURE INFORMATION PROPAGATION MODEL

=====

MODIFY MENU

1. Domain REFERENCES
2. Domain SYSTEMS
3. Domain MODULES
4. Domain FAILUREMODES
5. Domain PROPAGATIONS
6. Exit to MAIN MENU

Please enter LINE NUMBER:

FIGURE 34. MENU FOR MODIFYING FIPM DATA BASE RECORDS

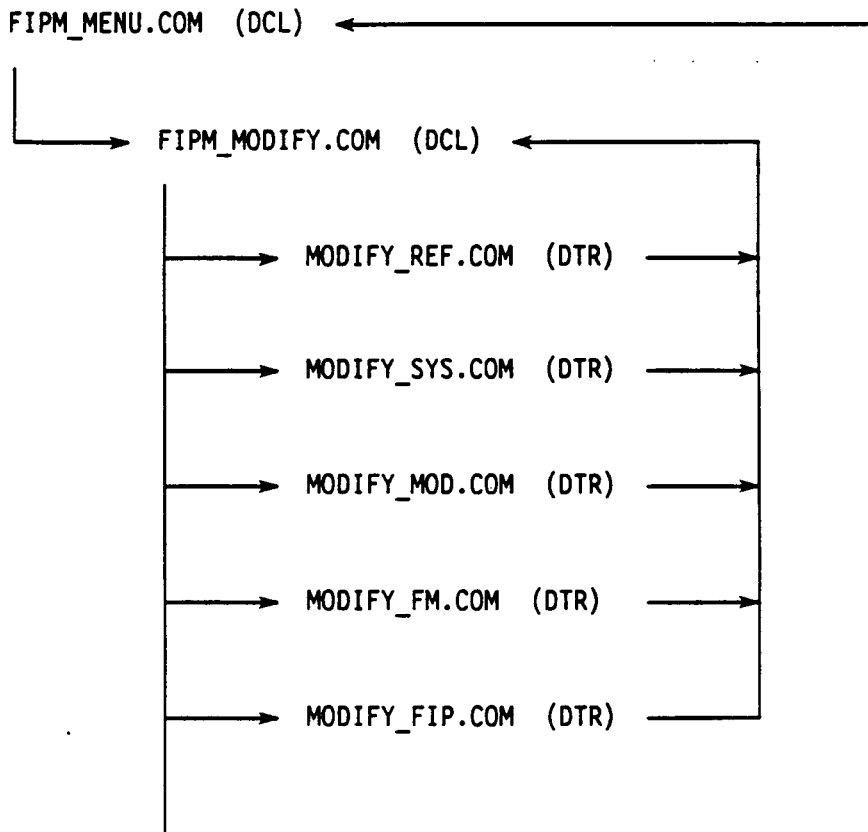

FIGURE 35. PROGRAM FLOW FOR MODIFYING FIPM DATA

If the user selects the list FIPM data option, the DCL procedure FIPM_LIST.COM is called to display the menu shown in Figure 36. A response of 1 through 6 will result in the execution of the Datatrieve command file LIST_REF_1.COM, LIST_SYS_1.COM, LIST_MOD_1.COM, LIST_FM_1.COM, LIST_CON_1.COM, or LIST_FIP_1.COM respectively. After executing the appropriate Datatrieve command file, the procedure FIPM_LIST.COM requests a yes or no response to list the records in the domain. A response of yes results in a batch job being submitted to generate the listing. The procedure then loops back to the list menu. A no response causes the immediate redisplay of the list menu. The user may elect to continue listing data for any of the displayed domains or may return to the main menu by selecting line number 7. The program flow for listing FIPM data is shown in Figure 37. A listing of the DCL command procedure FIPM_LIST.COM is included in Reference 4, Appendix D.

```
=====
                FAILURE INFORMATION PROPAGATION MODEL
=====
```

LIST MENU

1. Domain REFERENCES
2. Domain SYSTEMS
3. Domain MODULES
4. Domain FAILUREMODES
5. Domain CONNECTIONS
6. Domain PROPAGATIONS
7. Exit to MAIN MENU

Please enter LINE NUMBER:

FIGURE 36. MENU FOR LISTING FIPM DATA BASE RECORDS

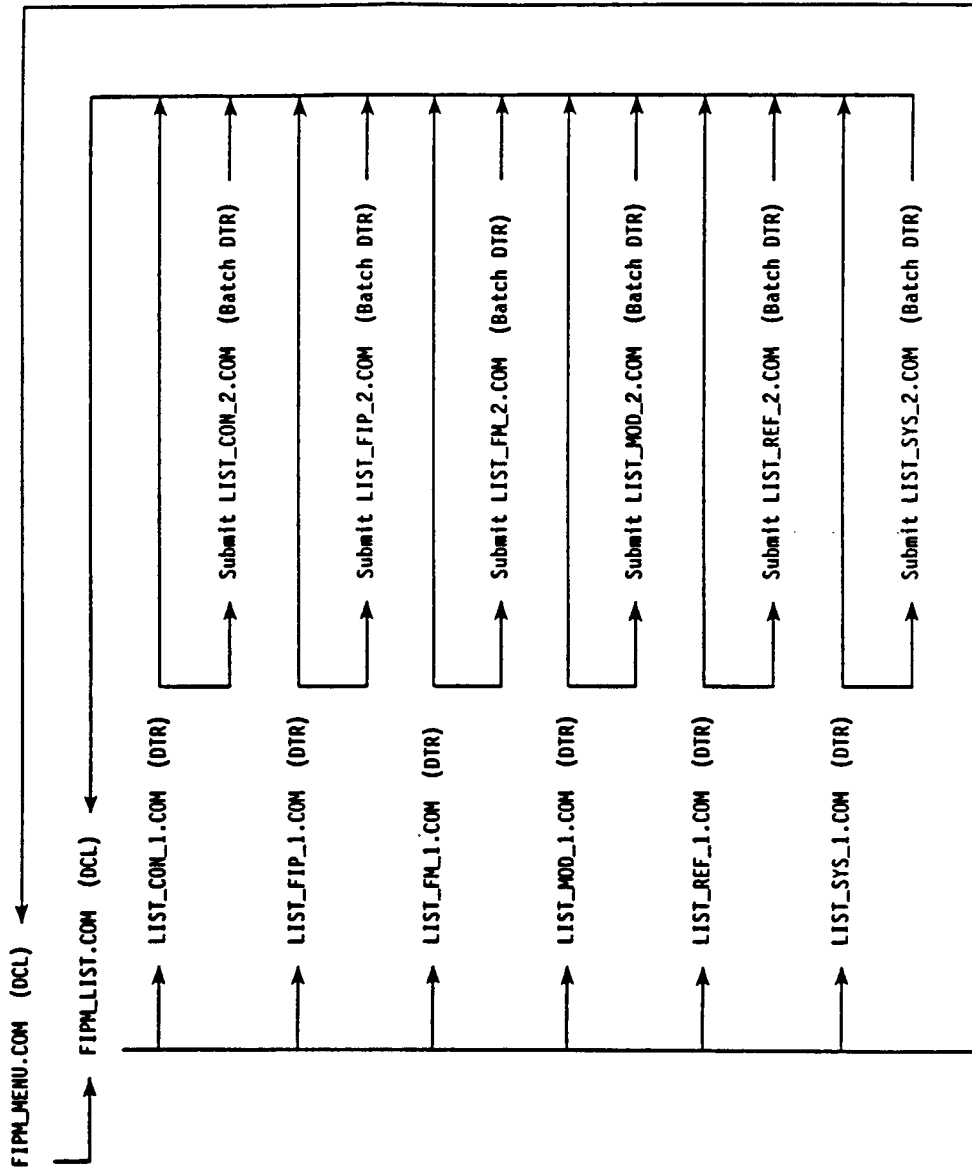

FIGURE 37. PROGRAM FLOW FOR LISTING FIPM DATA

Datatrieve Command Files, Procedures, and Tables

The actual storage, modification, and listing of FIPM information is performed using Datatrieve command files and procedures. Datatrieve command files are VAX system-level files which contain a series of Datatrieve commands and statements. These files are invoked from inside Datatrieve to perform the desired operations. Datatrieve procedures also contain a series of Datatrieve commands and statements. However, these procedures are stored in the VAX Common Data Dictionary (CDD). The CDD is used by Datatrieve to store and access the various elements associated with the data base.

The Datatrieve command files and procedures developed for the FIPM data base use Datatrieve tables to validate and supplement information being entered. An example of a Datatrieve table is shown in Figure 38. These tables are used to validate data by accepting only values which are in the table. They also provide additional data through translation of the value on the left-hand side of the colon into the value on the right-hand side. This latter function was especially useful for creating abbreviations to represent key FIPM data. The overall record size was reduced by storing the abbreviation rather than the entire value.

```

DEFINE TABLE REFERENCE_ABBREV_TABLE
!
"AEROJET"           : "AJ"
"BATTELLE"          : "BA"
"MARTIN MARIETTA"  : "MM"
"NASA HDQ"          : "NH"
"NASA MSFC"         : "NM"
"PRATT & WHITNEY"  : "PW"
"ROCKETDYNE"       : "RD"
!
END_TABLE

```

FIGURE 38. SAMPLE DATATRIEVE TABLE

The Datatrieve command files, procedures, and tables used to store FIPM information are shown in Figure 39. The command files STORE_REF.COM, STORE_SYS.COM, STORE_MOD.COM, STORE_FM.COM, STORE_CON.COM, and STORE_FIP.COM are executed by the DCL command procedure FIPM_STORE.COM (store menu). Each of these Datatrieve command files opens a log file to document the records being stored in the corresponding domain, prints the current date/time to the log file and then invokes the appropriate Datatrieve procedure(s). After completion of the storage activity, the program flow is returned to the command file where the current date/time is again printed before closing the log file. Execution is then returned to the DCL procedure FIPM_STORE.COM for redisplay of the store menu. The Datatrieve command files, procedures, and tables used to store FIPM data are included in Appendixes E, F, and G of Reference 4.

The Datatrieve command files, procedures, and tables used to modify FIPM information are shown in Figure 40. The command files MODIFY_REF.COM, MODIFY_SYS.COM, MODIFY_MOD.COM, MODIFY_FM.COM, and MODIFY_FIP.COM are executed by the DCL command procedure FIPM_MODIFY.COM (modify menu). Each of these Datatrieve command files opens a log file to document the records being modified in the corresponding domain, prints the current date/time to the log file and then invokes the appropriate Datatrieve procedure(s). After completion of the modification activity, the program flow is returned to the command file where the current date/time is again printed before closing the log file. Execution is then returned to the DCL procedure FIPM_MODIFY.COM for redisplay of the modify menu. The Datatrieve command files, procedures, and tables used to modify FIPM data are included in Appendixes E, F, and G of Reference 4.

Command Files:

```
STORE_CON.COM  
STORE_FIP.COM  
STORE_FM.COM  
STORE_MOD.COM  
STORE_REF.COM  
STORE_FIP.COM
```

Procedures:

```
BELL  
CLRSCRN  
CON_STORE  
CREATE_PROPAGATIONS_FIP_1  
CREATE_PROPAGATIONS_FIP_2  
CREATE_PROPAGATIONS_SYS_1  
CREATE_PROPAGATIONS_SYS_2  
DTR_NULL  
FIP_STORE  
FIP_STORE_1  
FIP_STORE_2  
FM_STORE  
MOD_STORE  
REF_STORE  
SYS_STORE
```

Tables:

```
ACCOMPLICE_REQUIRED_TABLE  
CONNECTION_TABLE  
FAILURE_MODE_SUBMODE_TABLE  
FMEA_ITEM_NAME_TABLE  
FREQ_TIME_UNITS_TABLE  
MONTH_TABLE  
PARAMETER_TABLE  
REFERENCE_ABBREV_TABLE  
REFERENCE_SOURCE_TABLE  
SIGNAL_TABLE
```

FIGURE 39. DATATRIEVE COMMAND FILES, PROCEDURES AND TABLES USED TO STORE FIPM DATA

Command Files:

MODIFY_FIP.COM
MODIFY_FM.COM
MODIFY_MOD.COM
MODIFY_REF.COM
MODIFY_SYS.COM

Procedures:

BELL
CLRSCRN
DTR_NULL
FIP_MODIFY
FIP_MODIFY_1
FIP_MODIFY_2
FIP_MODIFY_3
FIP_MODIFY_4
FM_MODIFY
FM_MODIFY_1
MOD_MODIFY
MOD_MODIFY_1
REF_MODIFY
REF_MODIFY_1
SYS_MODIFY
SYS_MODIFY_1
SYS_MODIFY_2

Tables:

FAILURE_MODE_SUBMODE_TABLE
FMEA_ITEM_NAME_TABLE
MONTH_TABLE
NUMBER_TABLE
PARAMETER_TABLE
REFERENCE_SOURCE_TABLE
SIGNAL_TABLE
SIGN_TABLE

FIGURE 40. DATATRIEVE COMMAND FILES, PROCEDURES AND TABLES USED TO MODIFY FIPM DATA

The Datatrieve command files, procedures, and tables used to list FIPM information are shown in Figure 41. The command files LIST_REF_1.COM, LIST_SYS_1.COM, LIST_MOD_1.COM, LIST_FM_1.COM, LIST_CON_1.COM, and LIST_FIP_1.COM are executed by the DCL command procedure FIPM_LIST.COM (list menu). Each of these Datatrieve command files counts the number of records in the corresponding domain and calculates the number of pages in the list file. This information is printed to the screen and program execution returns to FIPM_LIST.COM. If an actual listing is desired, the appropriate Datatrieve command file LIST_REF_2.COM, LIST_SYS_2.COM, LIST_MOD_2.COM, LIST_FM_2.COM, LIST_CON_2.COM, or LIST_FIP_2.COM is submitted as a batch job to generate the list file. Execution of the DCL procedure FIPM_LIST.COM then continues with redisplay of the list menu. The Datatrieve command files, procedures, and tables used to list FIPM data are included in Appendixes E, F, and G of Reference 4.

A number of Datatrieve procedures were used during the FIPM data base software development to simplify certain functions. As examples, the procedure CREATE_CONNECTIONS executes the file definition command for domain CONNECTIONS and the procedure S132 sets the terminal screen width to 132 characters. In addition to these procedures, the Datatrieve table FMEA_ITEM_PART_NO_TABLE was created to provide the Rocketdyne part numbers (Reference 3, Table 2-1) associated with specific FMEA items. These procedures and table are shown in Figure 42. Listings for the procedures are included in Reference 4, Appendix F and the table is included in Reference 4, Appendix G.

Command Files:

```

LIST_CON_1.COM
LIST_CON_2.COM
LIST_FIP_1.COM
LIST_FIP_2.COM
LIST_FM_1.COM
LIST_FM_2.COM
LIST_MOD_1.COM
LIST_MOD_2.COM
LIST_REF_1.COM
LIST_REF_2.COM
LIST_SYS_1.COM
LIST_SYS_2.COM

```

Procedures:

```

CLRSCRN
DTR_NULL
FIP_COUNT
FIP_COUNT_1
FIP_COUNT_2
FIP_LIST_1
FIP_LIST_2
FIP_LIST_3
FIP_LIST_4

```

FIGURE 41. DATATRIEVE COMMAND FILES AND PROCEDURES USED TO LIST FIPM DATA

Procedures:

```

CREATE_CONNECTIONS
CREATE_CONNECTIONS_FORM
CREATE_FAILUREMODES
CREATE_FAILUREMODES_FORM
CREATE_MODULES
CREATE_MODULES_FORM
CREATE_PROPAGATIONS
CREATE_PROPAGATIONS_FORM
CREATE_REFERENCES
CREATE_REFERENCES_FORM
CREATE_SYSTEMS
CREATE_SYSTEMS_FORM
FIPLOGICALC
FIPLOGICALD
HDR
PRNTOFF
PRNTON
S132
S80

```

Tables:

```

FMEA_ITEM_PART_NO_TABLE

```

FIGURE 42. MISCELLANEOUS DATATRIEVE PROCEDURES AND TABLES USED FOR FIPM

Terminal Data Management System Forms

Two TDMS utilities were used to create and compile terminal forms for use with the FIPM data base. These forms provide the interactive interface between the data base user and the underlying software. The specific utilities used were the Form Definition Utility (FDU) and the Request Definition Utility (RDU). FDU was used to create the screen image, define the video features, assign attributes to the various input fields, establish the field access order, and save the completed form in the Common Data Dictionary (CDD). The FIPM form definitions are included in Reference 4, Appendix H. The RDU was used to create a request library which identifies all of the FIPM forms. The VAX computer file associated with the compiled forms is also specified in the request library definition. Finally, RDU is used to build (compile) the request library and create the library file identified in the definition. The FIPM request library definition is shown in Figure 43.

```
FORM IS CONNECTIONS_STO_FORM;  
FORM IS FAILUREMODES_FIN1_FORM;  
FORM IS FAILUREMODES_FIN2_FORM;  
FORM IS FAILUREMODES_MOD1_FORM;  
FORM IS FAILUREMODES_MOD2_FORM;  
FORM IS FAILUREMODES_STO1_FORM;  
FORM IS FAILUREMODES_STO2_FORM;  
FORM IS MODULES_FIN_FORM;  
FORM IS MODULES_MOD_FORM;  
FORM IS MODULES_STO_FORM;  
FORM IS PROPAGATIONS_FIN_FORM;  
FORM IS PROPAGATIONS_MOD_FORM;  
FORM IS PROPAGATIONS_STO_FORM;  
FORM IS REFERENCES_FIN_FORM;  
FORM IS REFERENCES_MOD_FORM;  
FORM IS REFERENCES_STO_FORM;  
FORM IS SYSTEMS_FIN_FORM;  
FORM IS SYSTEMS_MOD_FORM;  
FORM IS SYSTEMS_STO_FORM;  
FILE IS "DEV$206:[BCDSSME2.FORMS]FORMSLIB.RLB";  
END DEFINITION;
```

FIGURE 43. FIPM REQUEST LIBRARY DEFINITION

(This page intentionally blank)

FIPM DATA BASE TRANSFER

A magnetic tape containing the FIPM data base development software and the high-pressure oxidizer turbopump (HPOTP) data files was mailed to the NASA Marshall Space Flight Center in February 1987. This tape was written using the VAX/VMS Backup Utility and contained multiple copies of 60 files. These files are shown in Figure 44. The file ACTIVATE.COM was a DCL command procedure developed to load and organize all of the required FIPM structure into a newly established VAX username. The 19 files of the type *.DAT are the data files associated with the HPOTP FIPM. The 28 files of the types FIPM_*.COM, LIST_*.COM, LOGIN.COM, MODIFY_*.COM, and STORE_*.COM are the DCL command procedures and Datatrive command files discussed in the previous section. The three files of the type CDD_FORMS_*.BAK contain the compiled form definitions as extracted from the CDD. The nine files of the type DTR_*.COM contain the Datatrive domain, record, procedure, and table definitions.

| | | |
|-----------------------|-----------------------|-----------------------|
| ACTIVATE.COM | CDD_FORMS_1.BAK | CDD_FORMS_2.BAK |
| CDD_FORMS_3.BAK | CONNECTIONS.DAT | CONNECTIONS_FORM.DAT |
| DTR_DOMAINS.COM | DTR_PROCS_1.COM | DTR_PROCS_2.COM |
| DTR_PROCS_3.COM | DTR_PROCS_4.COM | DTR_PROCS_5.COM |
| DTR_PROCS_6.COM | DTR_RECORDS.COM | DTR_TABLES.COM |
| FAILUREMODES.DAT | FAILUREMODES_FORM.DAT | FIPM_LIST.COM |
| FIPM_MENU.COM | FIPM_MODIFY.COM | FIPM_STORE.COM |
| LIST_CON_1.COM | LIST_CON_2.COM | LIST_FIP_1.COM |
| LIST_FIP_2.COM | LIST_FM_1.COM | LIST_FM_2.COM |
| LIST_MOD_1.COM | LIST_MOD_2.COM | LIST_REF_1.COM |
| LIST_REF_2.COM | LIST_SYS_1.COM | LIST_SYS_2.COM |
| LOGIN.COM | MODIFY_FIP.COM | MODIFY_FM.COM |
| MODIFY_MOD.COM | MODIFY_REF.COM | MODIFY_SYS.COM |
| MODULES.DAT | MODULES_FORM.DAT | PROPAGATIONS_A150.DAT |
| PROPAGATIONS_A200.DAT | PROPAGATIONS_A600.DAT | PROPAGATIONS_A700.DAT |
| PROPAGATIONS_B400.DAT | PROPAGATIONS_B800.DAT | PROPAGATIONS_C200.DAT |
| PROPAGATIONS_FORM.DAT | PROPAGATIONS_Z910.DAT | REFERENCES.DAT |
| REFERENCES_FORM.DAT | STORE_CON.COM | STORE_FIP.COM |
| STORE_FM.COM | STORE_MOD.COM | STORE_REF.COM |
| STORE_SYS.COM | SYSTEMS.DAT | SYSTEMS_FORM.DAT |

Total of 60 files.

FIGURE 44. VAX/VMS FILES USED TO TRANSFER FIPM DATA BASE

The procedure `ACTIVATE.COM` created the necessary VAX/VMS directory structure, created a Datatrieve dictionary, loaded all of the Datatrieve elements (domains, records, procedures, and tables), defined a TDMS request library and built the TDMS request library file. A listing of the file `ACTIVATE.COM` is included in Reference 4, Appendix D. The resulting VAX directory structure is shown in Figure 45. The top-level directory, `[BCDSSME2]`, contains the other directory files, the Datatrieve dictionary file, and two DCL command procedures. The files contained in this directory are shown in Figure 46. The directory `[BCDSSME2.DATA]` contains the FIPM data files as shown in Figure 47. The directory `[BCDSSME2.DTR]` is used as a holding area for the command files containing the Datatrieve domain, record, procedure, and table definitions. The files in this directory are shown in Figure 48. The directory `[BCDSSME2.FIPM]` contains the DCL command procedures and Datatrieve command files which display the FIPM menus and interact with the data base. These files are shown in Figure 49. The directory `[BCDSSME2.FORMS]` contains the compiled form definition files and the request library file as shown in Figure 50. The directories `[BCDSSME2.LISTS]`, `[BCDSSME2.LOGS]`, and `[BCDSSME2.MISC]` are initially empty. Any FIPM listing files generated by the FIPM software will be written to the `[BCDSSME2.LISTS]` directory. The log files which are created as FIPM records are stored or modified are written to the directory `[BCDSSME2.LOGS]`. The final directory, `[BCDSSME2.MISC]`, was included for miscellaneous files which may be created by the user.

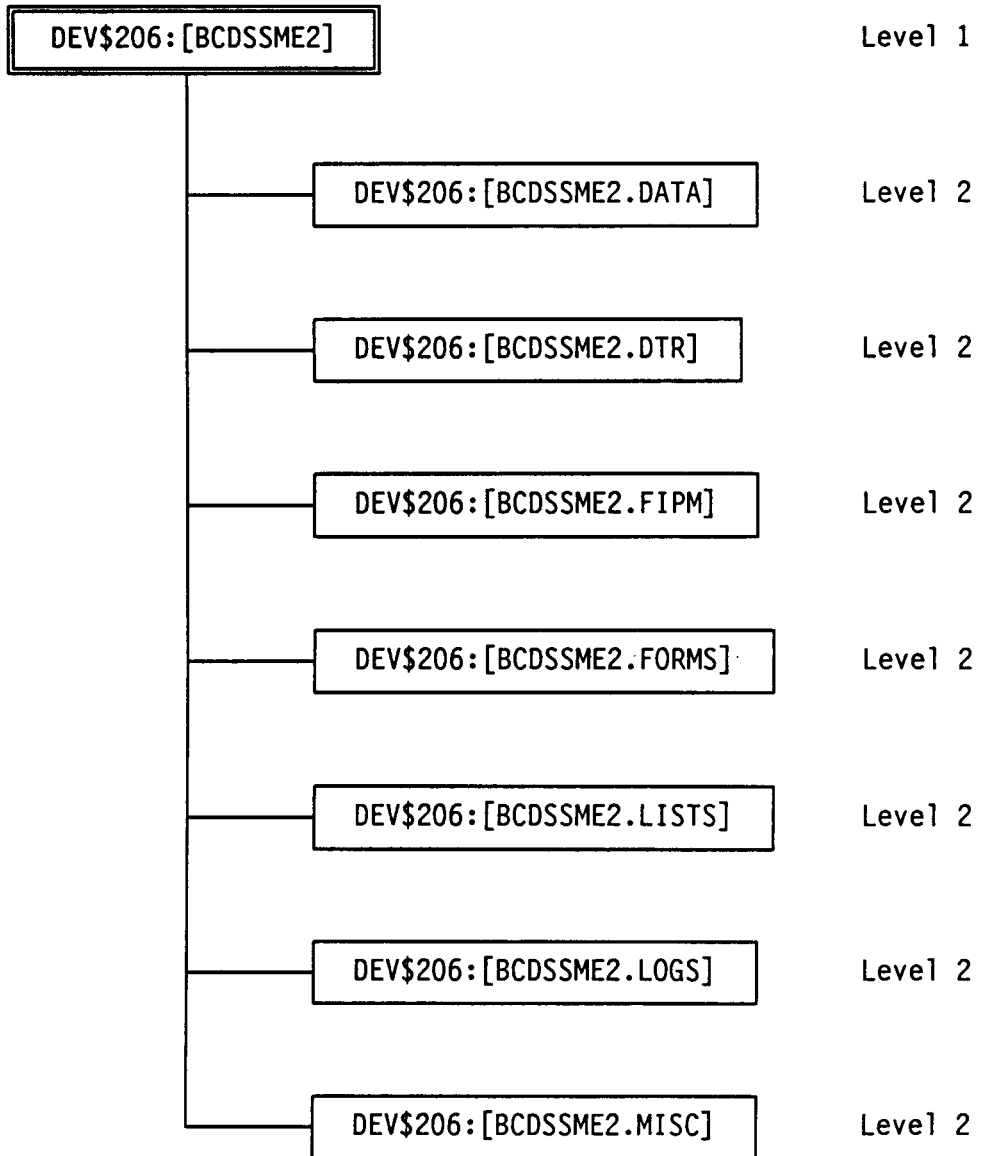

FIGURE 45. FIPM DIRECTORY STRUCTURE

ACTIVATE.COM
DATA.DIR
DTR.DIR
FIPM.DIR
FORMS.DIR
LISTS.DIR
LOGIN.COM
LOGS.DIR
MISC.DIR
SSME.DIC

Total of 10 files.

FIGURE 46. DIRECTORY DEV\$206:[BCDSSME2]

CONNECTIONS.DAT
CONNECTIONS_FORM.DAT
FAILUREMODES.DAT
FAILUREMODES_FORM.DAT
MODULES.DAT
MODULES_FORM.DAT
PROPAGATIONS_A150.DAT
PROPAGATIONS_A200.DAT
PROPAGATIONS_A600.DAT
PROPAGATIONS_A700.DAT
PROPAGATIONS_B400.DAT
PROPAGATIONS_B800.DAT
PROPAGATIONS_C200.DAT
PROPAGATIONS_FORM.DAT
PROPAGATIONS_Z910.DAT
REFERENCES.DAT
REFERENCES_FORM.DAT
SYSTEMS.DAT
SYSTEMS_FORM.DAT

Total of 19 files.

FIGURE 47. DIRECTORY DEV\$206:[BCDSSME2.DATA]

DTR_DOMAINS.COM
DTR_PROCS_1.COM
DTR_PROCS_2.COM
DTR_PROCS_3.COM
DTR_PROCS_4.COM
DTR_PROCS_5.COM
DTR_PROCS_6.COM
DTR_RECORDS.COM
DTR_TABLES.COM

Total of 9 files.

FIGURE 48. DIRECTORY DEV\$206:[BCDSSME2.DTR]

| | |
|-----------------|----------------|
| FIPM_LIST.COM | FIPM_MENU.COM |
| FIPM_MODIFY.COM | FIPM_STORE.COM |
| LIST_CON_1.COM | LIST_CON_2.COM |
| LIST_FIP_1.COM | LIST_FIP_2.COM |
| LIST_FM_1.COM | LIST_FM_2.COM |
| LIST_MOD_1.COM | LIST_MOD_2.COM |
| LIST_REF_1.COM | LIST_REF_2.COM |
| LIST_SYS_1.COM | LIST_SYS_2.COM |
| MODIFY_FIP.COM | MODIFY_FM.COM |
| MODIFY_MOD.COM | MODIFY_REF.COM |
| MODIFY_SYS.COM | STORE_CON.COM |
| STORE_FIP.COM | STORE_FM.COM |
| STORE_MOD.COM | STORE_REF.COM |
| STORE_SYS.COM | |

Total of 27 files.

FIGURE 49. DIRECTORY DEV\$206:[BCDSSME2.FIPM]

CDD_FORMS_1.BAK
CDD_FORMS_2.BAK
CDD_FORMS_3.BAK
FORMSLIB.RLB

Total of 4 files.

FIGURE 50. DIRECTORY DEV\$206:[BCDSSME2.FORMS]

(This page intentionally blank)

HIGH-PRESSURE OXIDIZER TURBOPUMP FIPM

The first SSME component analyzed using the failure information propagation model (FIPM) was the high-pressure oxidizer turbopump (HPOTP). One of the reasons for selecting the HPOTP was the relatively high number of unsatisfactory condition reports (UCRs) associated with this component. The HPOTP also received a very high score in the failure mode ranking which considered the cost, risk, and time factors connected with various component failure modes. A major area of concern for the HPOTP is ball bearing wear and cage delamination. Another item which has received considerable attention is cracking of the hot-gas turbine blades. Both of these areas have been the focus of extensive efforts by NASA and Rocketdyne to identify and diagnose degradation of the respective parts. All of these factors made the HPOTP an attractive candidate for the initial FIPM.

The HPOTP failure information propagation model consists of the following items:

- HPOTP FIPM drawing
- HPOTP data stored in the FIPM data base.

Specific details concerning each of these elements are provided later in this section.

Definition of High-Pressure Oxidizer Turbopump

The high-pressure oxidizer turbopump is designated in the FIPM data base as System B400. The failure information propagation model for this system includes the following Rocketdyne FMEA items:

- High-pressure oxidizer turbopump (B400)
- Low-pressure oxidizer turbopump turbine drive duct (K202)
- High-pressure oxidizer duct (K205)
- Fuel preburner oxidizer supply duct (K206)
- Preburner pump inlet duct (K208)
- Oxidizer preburner oxidizer supply duct (K212).

References 3, 5, and 6 of this report were the principal sources used during the preparation of this FIPM.

High-Pressure Oxidizer Turbopump FIPM Drawing

The HPOTP FIPM drawing is included in Appendix B of this report. The drawing for the HPOTP (System B400) includes the following features:

- 8 systems (B400 plus 7 adjacent)
- 105 modules
- 198 connections
- 260 failure modes.

The actual HPOTP, including associated engine items such as ducts and lines, is depicted by 90 modules (boxes). The remaining 15 modules are piece-parts or functions of adjacent engine systems such as System A150 (heat exchanger). The modules which are not part of the HPOTP are easily identified by the diagonal lines in the lower portion of the box. Of the 198 connections (lines) shown on the diagram, 29 represent physical paths to the various external systems. The remaining 169 connections are internal to the HPOTP.

High-Pressure Oxidizer Turbopump FIPM Data

The information which collectively defines the HPOTP FIPM is stored in a total of six domains. The domains which contain HPOTP FIPM information include:

- SYSTEMS
- MODULES
- FAILUREMODES (failure modes)
- CONNECTIONS
- PROPAGATIONS_B400 (failure information propagations)
- REFERENCES.

The key relationships between records in the various FIPM domains are illustrated in Figure 51. The domains SYSTEMS, MODULES, FAILUREMODES, CONNECTIONS, and REFERENCES store records for all of the various engine components (systems) being modeled. The domain PROPAGATIONS_B400 includes failure information propagations only for the HPOTP (System B400). Details concerning the data content and number of HPOTP records for each of these domains or files are provided in the following subsections of this report.

Systems Data File

There are eight records in the domain SYSTEMS which are associated with the HPOTP FIPM. The current data for each of these records are included in Reference 7, Appendix B. All of the records in domain SYSTEMS contain the 31 data fields shown in Figure 52. The field names are shown to the left of the colons. The data stored in the fields are found to the right of the colons.

The DATE_CREATED, DATE_LAST_MODIFIED, and MODIFYING_PROCEDURE fields are used for tracking purposes. DATE_CREATED is the date that the record was first stored in the data base. DATE_LAST_MODIFIED is the date of the most recent record modification. MODIFYING_PROCEDURE identifies the procedure which performed the last record modification. All three of these fields are automatically assigned by the appropriate Datatrieve entry and modification procedures. The field SYSTEM contains the four-character code which is used to represent a given system. SYSTEM_NAME is the FIPM name associated with the system designation. ITEM1 through ITEM15 are the Rocketdyne FMEA items which are included in a particular system. REFERENCE1 through REFERENCE10 contain the five-character codes which represent various reference documents used to define the current system. The field PROPAGATIONS_FILE_CREATED is used by one of several Datatrieve procedures to create a corresponding failure information propagation file for this system.

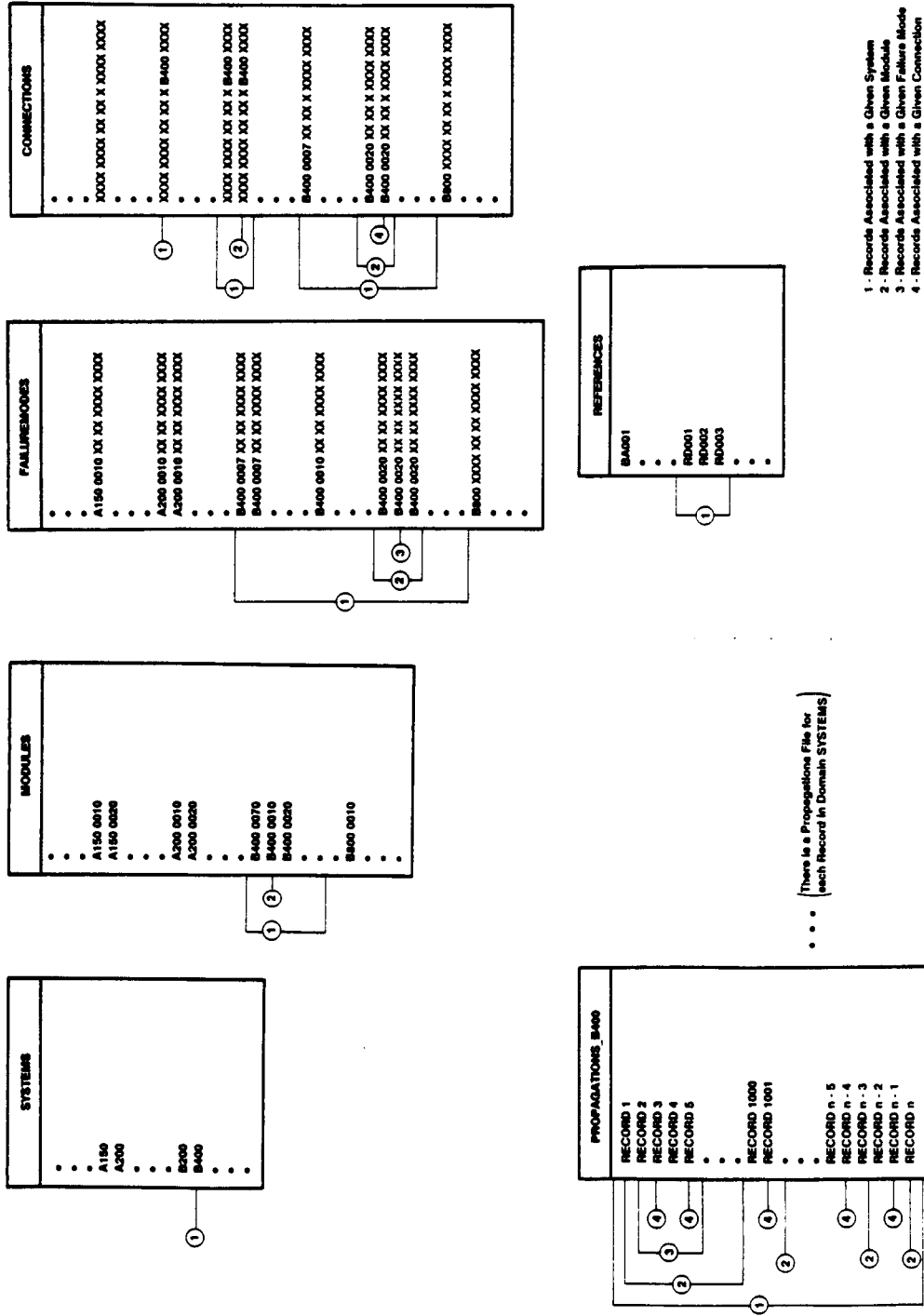

FIGURE 51. RELATIONSHIPS BETWEEN DATA RECORDS IN FIPM DOMAINS

```
DATE_CREATED           : 11-Dec-1986 14:12:18.51
SYSTEM                 : B400
SYSTEM_NAME            :
HIGH-PRESSURE OXIDIZER TURBOPUMP
ITEM1                  : B400
ITEM2                  : K202
ITEM3                  : K205
ITEM4                  : K206
ITEM5                  : K208
ITEM6                  : K212
ITEM7                  :
ITEM8                  :
ITEM9                  :
ITEM10                 :
ITEM11                 :
ITEM12                 :
ITEM13                 :
ITEM14                 :
ITEM15                 :
REFERENCE1             : RD001
REFERENCE2             : RD002
REFERENCE3             : RD003
REFERENCE4             :
REFERENCE5             :
REFERENCE6             :
REFERENCE7             :
REFERENCE8             :
REFERENCE9             :
REFERENCE10            :
PROPAGATIONS_FILE_CREATED : YES
DATE_LAST_MODIFIED    : 11-Dec-1986 14:23:28.22
MODIFYING_PROCEDURE    : SYS_STORE
```

FIGURE 52. SAMPLE RECORD FROM DOMAIN SYSTEMS

Additional descriptive information pertaining to the FMEA items may be obtained by printing the item number via FMEA_ITEM_NAME_TABLE or FMEA_ITEM_PART_NO_TABLE. Additional data on any references shown may be located by finding the record in domain REFERENCES with REFERENCE_NUMBER equal to the appropriate code.

Modules Data File

There are 105 records in the domain MODULES which are associated with the HPOTP FIPM. The current data for each of these records are included in Reference 7, Appendix C. All of the records in domain MODULES contain the six data fields shown in Figure 53. The field names are shown to the left of the colons. The data stored in the fields are found to the right of the colons.

```

DATE_CREATED           : 11-Dec-1986 15:56:10.02
SYSTEM_MODULE          : B4000010
SYSTEM_MODULE_NAME     :
FIRST-STAGE TURBINE BLADE DAMPERS
SYSTEM_MODULE_FUNCTION :
ALTER VIBRATIONAL MODES OF 1ST-STAGE TURBINE BLADES
DATE_LAST_MODIFIED    :
MODIFYING_PROCEDURE   :

```

FIGURE 53. SAMPLE RECORD FROM DOMAIN MODULES

The DATE_CREATED, DATE_LAST_MODIFIED, and MODIFYING_PROCEDURE fields are used for tracking purposes. DATE_CREATED is the date that the record was first stored in the data base. DATE_LAST_MODIFIED is the date of the most recent record modification. MODIFYING_PROCEDURE identifies the procedure which performed the last record modification. All three of these fields are automatically assigned by the appropriate Datatrieve entry and modification procedures. The field SYSTEM_MODULE contains the composite eight-character code which identifies a given module. The first

four characters are the respective system and the last four characters are the module number. SYSTEM_MODULE_NAME is the FIPM name for this module. SYSTEM_MODULE_FUNCTION is a brief statement of the function or purpose of this particular module.

Additional descriptive information pertaining to the specified system may be obtained by finding the record in domain SYSTEMS with the field SYSTEM equal to the appropriate code.

Failure Modes Data File

There are 260 records in the domain FAILUREMODES which are associated with the HPOTP FIPM. The current data for each of these records are included in Reference 7, Appendix D. All of the records in domain FAILUREMODES contain the 11 data fields shown in Figure 54. The field names are shown to the left of the colons. The data stored in the fields are found to the right of the colons.

```

DATE_CREATED      : 19-Nov-1986 14:54:35.22
FMCODE           : B4000050WRRBB4000040
DESCRIPTION      :
ABRASION DUE TO MECHANICAL CONTACT BETWEEN COMPONENTS WITH RELATIVE MOTION
(1ST-STAGE TURBINE BLADES WITH 1ST-STAGE TURBINE STATOR)
EFFECT1         :
REDUCED SPEED (RPM) OF SHAFT ASSEMBLY
EFFECT2         :
INCREASED VIBRATION OF SHAFT ASSEMBLY (TURBINE END)
EFFECT3         :
REDUCTION OF TURBINE EFFICIENCY
EFFECT4         :
INCREASED TORQUE VALUE FOR HPOTP (GROUND TEST)
EFFECT5         :
EXTREME REDUCTION IN LIFE OF 1ST-STAGE BLADES AND 1ST-STAGE STATOR
EFFECT6         :

DATE_LAST_MODIFIED :
MODIFYING_PROCEDURE :
```

FIGURE 54. SAMPLE RECORD FROM DOMAIN FAILUREMODES

The DATE_CREATED, DATE_LAST_MODIFIED, and MODIFYING_PROCEDURE fields are used for tracking purposes. DATE_CREATED is the date that the record was first stored in the data base. DATE_LAST_MODIFIED is the date of the most recent record modification. MODIFYING_PROCEDURE identifies the procedure which performed the last record modification. All three of these fields are automatically assigned by the appropriate Datatrieve entry and modification procedures. FMCODE is a 20-character code which identifies and describes a particular failure mode. The constituent elements of this failure mode code are detailed in Figure 55. DESCRIPTION is a brief statement which includes specific details on the failure mode. EFFECT1 through EFFECT6 are qualitative statements which describe probable effects of the failure mode.

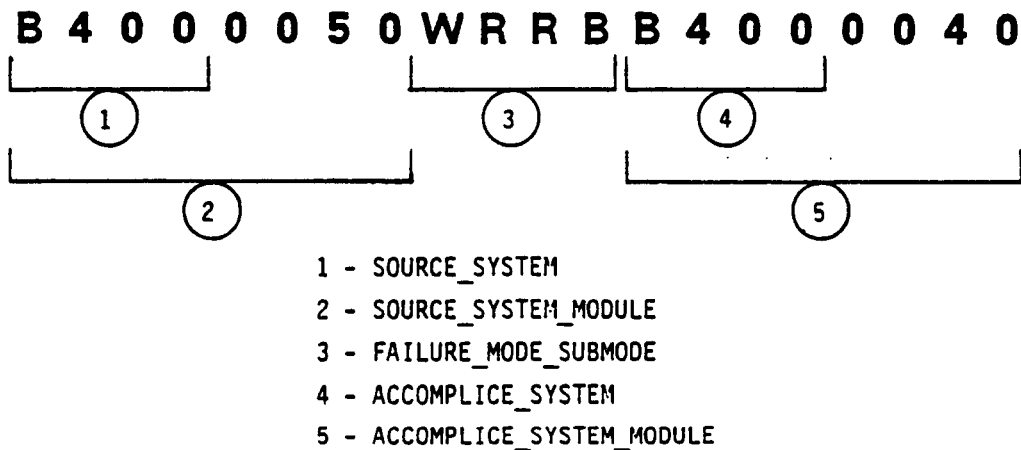

FIGURE 55. ELEMENTS REPRESENTED BY FMCODE

Additional descriptive information pertaining to the source and accomplice systems may be obtained by finding the records in domain SYSTEMS with the field SYSTEM equal to the appropriate codes. Additional data on the source and accomplice modules may be located by finding the records in domain MODULES with SYSTEM_MODULE equal to the respective

codes. The failure mode and submode may be obtained by printing the abbreviation via FAILURE_MODE_SUBMODE_TABLE.

Connections Data File

There are 198 records in the domain CONNECTIONS which are associated with the HPOTP FIPM. The current data for each of these records are included in Reference 7, Appendix E. All of the records in domain CONNECTIONS contain the four data fields shown in Figure 56. The field names are shown to the left of the colons. The data stored in the fields are found to the right of the colons.

```
DATE_CREATED      : 18-Dec-1986 10:40:23.62
CODE_NUMBER       : B4000380LQO2TZ9101000
DATE_LAST_MODIFIED :
MODIFYING_PROCEDURE :
```

FIGURE 56. SAMPLE RECORD FROM DOMAIN CONNECTIONS

The DATE_CREATED, DATE_LAST_MODIFIED, and MODIFYING_PROCEDURE fields are used for tracking purposes. DATE_CREATED is the date that the record was first stored in the data base. DATE_LAST_MODIFIED is the date of the most recent record modification. MODIFYING_PROCEDURE identifies the procedure which performed the last record modification. All three of these fields are automatically assigned by the appropriate Datatrieve entry and modification procedures. CODE_NUMBER is a 21-character code which identifies and describes a specific connection. The constituent elements of CODE_NUMBER are shown in Figure 57.

Additional descriptive information pertaining to the respective systems may be obtained by finding the records in domain SYSTEMS with the field SYSTEM equal to the appropriate codes. Additional data on the two modules involved may be located by finding the records in domain MODULES

with SYSTEM_MODULE equal to the respective codes. The connection type and qualifier may be obtained by printing the abbreviation via CONNECTION_TABLE.

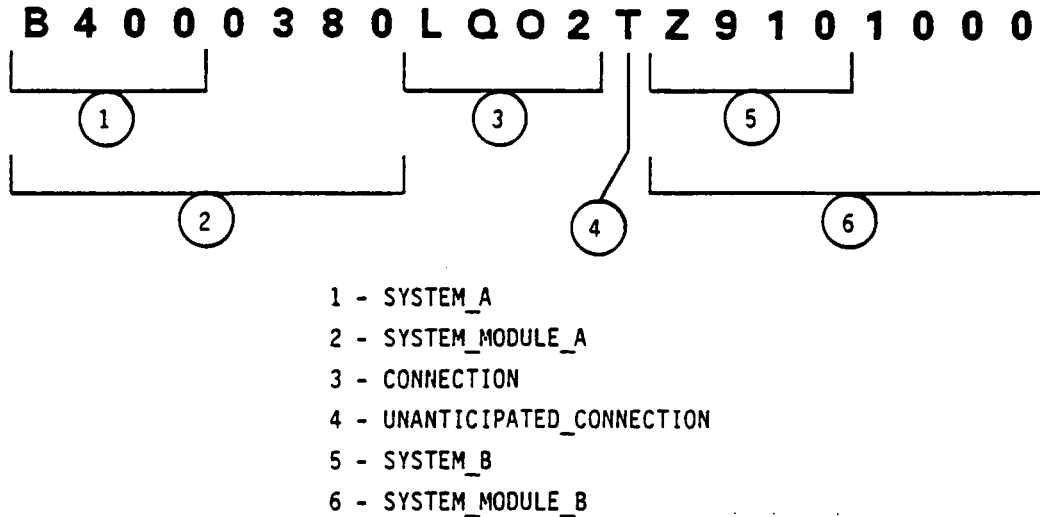

FIGURE 57. ELEMENTS CONTAINED IN CODE_NUMBER

Failure Information Propagations Data File

All of the 8213 records in the domain PROPAGATIONS_B400 are associated with the HPOTP FIPM. A partial listing of the current data for each of these records is included in Reference 7, Appendix F. All of the records in domain PROPAGATIONS_B400 contain the 20 data fields shown in Figure 58. The field names are shown to the left of the colons. The data stored in the fields are found to the right of the colons.

```

DATE_CREATED      : 18-Apr-1986 13:31:20.30
FMCODE           : B4000010FAVF----0000
CODE_NUMBER      : B4000010ME--FB4000050
SIGNAL_TYPE      : VIBRATION
SIGNAL_UNITS     : ACCELERATION-G
DIMENSIONS       : 1
SIGNAL_QUALITY   : 1
MAX_FREQ_OR_TIME : 3
MIN_FREQ_OR_TIME : 2
FT_UNITS         : HERTZ
PARAMETER        : AMPLITUDE
PARAMETER_UNITS  : SAME AS SIGNAL UNITS
SYMPTOM_DURATION : 1
PERIOD_OF_ONSET  : 2
INDICATES_FAILURE : T
COMMENT1         :
VIBRATION AMPLITUDE CHANGES WITH CRACK GROWTH
COMMENT2         :
NATURAL FREQUENCY MAY CHANGE AS A FUNCTION OF CRACKING
COMMENT3         :
POSSIBILITY OF TRENDING GROSS VIBRATION AND TEMPERATURE LEVELS
DATE_LAST_MODIFIED : 2-Sep-1986 14:22:18.33
MODIFYING_PROCEDURE : FIP_MODIFY

```

FIGURE 58. SAMPLE RECORD FROM DOMAIN PROPAGATIONS_B400

The DATE_CREATED, DATE_LAST_MODIFIED, and MODIFYING_PROCEDURE fields are used for tracking purposes. DATE_CREATED is the date that the record was first stored in the data base. DATE_LAST_MODIFIED is the date of the most recent record modification. MODIFYING_PROCEDURE identifies the procedure which performed the last record modification. All three of these fields are automatically assigned by the appropriate Datatrieve entry and modification procedures. FMCODE is the 20-character code which identifies the particular failure mode being propagated. The elements of this code are described in the previous subsection on failure modes. CODE_NUMBER is the 21-character code which specifies the connection to which the given failure information has propagated. The information contained in this code is discussed in the earlier subsection on

connections. SIGNAL_TYPE identifies the physical nature of the failure information such as vibration, thermal, etc. SIGNAL_UNITS are the units of measure associated with the specified signal. DIMENSIONS is the spatial resolution which can be obtained from a specific signal type (e.g., thermal is a one-dimensional signal while acoustic can provide two-dimensional information). SIGNAL_QUALITY is an estimate of the relative strength of the given failure signal at this particular location (connection). MAX_FREQ_OR_TIME and MIN_FREQ_OR_TIME define the frequency/time range associated with this signal. FT_UNITS are the physical units associated with the maximum and minimum frequency/time. PARAMETER identifies the sensitive or important feature of the failure signal such as amplitude. PARAMETER_UNITS are the units assigned to a particular parameter. SYMPTOM_DURATION is an estimate of the time between the initiation of a detectable, symptomatic signal and the actual component failure. PERIOD_OF_ONSET is a projection of the operational time which can be accumulated before failure symptoms are likely to occur. INDICATES_FAILURE is a true or false statement of whether the given failure information indicates that the failure has occurred. COMMENT1 through COMMENT3 are brief statements which provide additional data pertinent to the failure information propagation being described. All of the various unit fields are assigned by the Datatrieve input procedure based on predefined relationships.

Additional descriptive information pertaining to the given FMCODE may be obtained by finding the record in domain FAILUREMODES with the identical value for this field.

References Data File

There are three records in the domain REFERENCES which are associated with the HPOTP FIPM. The current data for each of these records are included in Reference 7, Appendix G. All of the records in domain REFERENCES contain the 13 data fields shown in Figure 59. The field names are shown to the left of the colons. The data stored in the fields are found to the right of the colons.

```

DATE_CREATED      : 20-Nov-1986 15:47:21.52
REFERENCE_NUMBER  : RD001
AUTHOR1           :
AUTHOR2           :
AUTHOR3           :
AUTHOR4           :
DOCUMENT_TITLE    :
SPACE TRANSPORTATION SYSTEM TECHNICAL MANUAL, SSME DESCRIPTION AND OPERATION
(INPUT DATA), SPACE SHUTTLE MAIN ENGINE, PART NUMBER RS007001
DOCUMENT_SOURCE   : ROCKETDYNE
DOCUMENT_NUMBER   : E41000, RSS-8559-1-1-1
DOCUMENT_DATE     : 05-APR-1982
CONTRACT_NUMBER   : NAS8-27980
DATE_LAST_MODIFIED :
MODIFYING_PROCEDURE :

```

FIGURE 59. SAMPLE RECORD FROM DOMAIN REFERENCES

The DATE_CREATED, DATE_LAST_MODIFIED, and MODIFYING_PROCEDURE fields are used for tracking purposes. DATE_CREATED is the date that the record was first stored in the data base. DATE_LAST_MODIFIED is the date of the most recent record modification. MODIFYING_PROCEDURE identifies the procedure which performed the last record modification. All three of these fields are automatically assigned by the appropriate Datatrieve entry and modification procedures. REFERENCE_NUMBER is a five-character code assigned to the reference during data entry. This number is generated by the input procedure. AUTHOR1 through AUTHOR4 are any authors which are listed for the reference being cited. DOCUMENT_TITLE is the title of the report, book, etc. DOCUMENT_SOURCE identifies the organization or company which produced the item being referenced. DOCUMENT_NUMBER is any identifying number assigned by the source organization or company. DOCUMENT_DATE is the date of publication. CONTRACT_NUMBER indicates the government contract number under which the work was performed.

(This page intentionally blank).

SSME FIPM DRAWINGS

In addition to the high-pressure oxidizer turbopump FIPM drawing discussed in the previous section, FIPM drawings were generated for the following nine SSME systems:

- A150 - Heat exchanger (HE)
- A200 - Main injector
- A330 - Main combustion chamber (MCC)
- A340 - Nozzle
- A600 - Fuel preburner (FPB)
- A700 - Oxidizer preburner (OPB)
- B200 - High-pressure fuel turbopump (HPFTP)
- B600 - Low-pressure fuel turbopump (LPFTP)
- B800 - Low-pressure oxidizer turbopump (LPOTP)

All of the FIPM drawings are included in Appendix B of this report.

The heat exchanger (A150) FIPM drawing depicts a total of 36 modules. Of this number, 24 are modules of A150 while the remaining 12 are modules of external systems. The drawing also shows 68 connections. 51 of these are internal to this system while 17 are external connections. A total of 69 failure modes have been identified for the various modules comprising system A150.

The main injector (A200) FIPM drawing depicts a total of 52 modules. Of this number, 36 are modules of A200 while the remaining 16 are modules of external systems. The drawing also shows 123 connections. 77 of these are internal to this system while 46 are external connections. A total of 95 failure modes have been identified for the various modules comprising system A200.

The main combustion chamber (A330) FIPM drawing depicts a total of 28 modules. Of this number, 18 are modules of A330 while the remaining 10 are modules of external systems. The drawing also shows 42 connections. 29 of these are internal to this system while 13 are

external connections. A total of 48 failure modes have been identified for the various modules comprising system A330.

The nozzle (A340) FIPM drawing depicts a total of 54 modules. Of this number, 41 are modules of A340 while the remaining 13 are modules of external systems. The drawing also shows 88 connections. 63 of these are internal to this system while 25 are external connections. A total of 132 failure modes have been identified for the various modules comprising system A340.

The fuel preburner (A600) FIPM drawing depicts a total of 43 modules. Of this number, 27 are modules of A600 while the remaining 16 are modules of external systems. The drawing also shows 100 connections. 70 of these are internal to this system while 30 are external connections. A total of 89 failure modes have been identified for the various modules comprising system A600.

The oxidizer preburner (A700) FIPM drawing depicts a total of 43 modules. Of this number, 27 are modules of A700 while the remaining 16 are modules of external systems. The drawing also shows 94 connections. 62 of these are internal to this system while 32 are external connections. A total of 85 failure modes have been identified for the various modules comprising system A700.

The high-pressure fuel turbopump (B200) FIPM drawing depicts a total of 101 modules. Of this number, 94 are modules of B200 while the remaining 7 are modules of external systems. The drawing also shows 197 connections. 181 of these are internal to this system while 16 are external connections. A total of 281 failure modes have been identified for the various modules comprising system B200.

The low-pressure fuel turbopump (B600) FIPM drawing depicts a total of 54 modules. Of this number, 47 are modules of B600 while the remaining 7 are modules of external systems. The drawing also shows 99 connections. 89 of these are internal to this system while 10 are external connections. A total of 123 failure modes have been identified for the various modules comprising system B600.

The low-pressure oxidizer turbopump (B800) FIPM drawing depicts a total of 49 modules. Of this number, 44 are modules of B800 while the

remaining 5 are modules of external systems. The drawing also shows 89 connections. 81 of these are internal to this system while 8 are external connections. A total of 150 failure modes have been identified for the various modules comprising system B800.

(This page intentionally blank)

HPOTP DIAGNOSTIC ASSESSMENTPresent Instrumentation

There is presently instrumentation for eight different measurements on the HPOTP. These measurements are shown in Table 17. These sensors can pick up information for many failure modes as shown in the FIPM output listings in Table 18. The problem is in isolating the component failing from the information available. This is especially true for the accelerometers, which can detect information for over 81 failure modes. Also, most of the information available cannot directly determine if a failure is imminent or has occurred, but can only give an indication of the environment the components are subjected to for trending information. On the positive side, only a few of the failure modes have been a problem, so even though there is a possibility of many failure modes having the same signature, there is a high probability that it can be narrowed down to a few failure modes.

The FIPM model assumes that the system depicted is in the near-normal state and that it models the propagation of failure information, not the failure itself. The failure information at each sensor will be discussed along with the possible capability to discriminate the individual failure modes from the information at each sensor. Then, with knowledge of the critical failure modes and instrumentation under development, possible test points have been investigated for isolation of the important failure information. These test points will be discussed later in this section.

TABLE 17. PRESENT HPOTP INSTRUMENTATION

| Measurement | Location | |
|--|------------------------------|--|
| | Connection | Description |
| 1. LPOTP Discharge Pressure | B800 9910 LQ 02 F B400 0350 | 11 Inches Upstream of HPOTP Inlet Flange |
| 2. HPOTP Discharge Pressure | B400 0380 LQ 02 F B400 0390 | 25 Inches Downstream of HPOTP Discharge Flange |
| 3. Preburner Pump Discharge Pressure | B400 0620 LQ 02 F B400 0630 | 17 Inches Downstream of Preburner Pump Discharge Flange |
| 4. Preburner Pump Discharge Temperature | B400 0620 LQ 02 F B400 0630 | Same As Above |
| 5. HPOTP Turbine Discharge Temperature | B400 0080 GA HG F A150 9930 | Hot Gas Manifold-HPOTP Turbine Discharge |
| 6. HPOTP Secondary Turbine Seal Drain Pressure | B400 0170 GA HG T B400 01800 | HPOTP Secondary Seal Drain Flange |
| 7. HPOTP Intermediate Seal Helium Purge Pressure | C200 9910 GA HE F B400 0260 | Pneumatic Control Assembly Purge Supply |
| 8. HPOTP Radial Accelerometer 45° HPOTP Radial Accelerometer 135° | B400 0570 ME CP F B400 0600 | HPOTP Preburner Pump Flange 45° and 135° Around From Inlet |

TABLE 18. FAILURE INFORMATION FOR CURRENT INSTRUMENTATION

Domain PROPAGATIONS_B400

20-Apr-1987 14:58

| Rec. No. | Failure Mode | Dim. | Sig. Qual. | Max. Freq. Time | Min. Freq. Time | Freq. Time Unit | Sym. Dur. | Pd. Onset | Ind. Fail. |
|----------|--------------|------|------------|-----------------|-----------------|-----------------|-----------|-----------|------------|
|----------|--------------|------|------------|-----------------|-----------------|-----------------|-----------|-----------|------------|

CODE_NUMBER : A150 9930 GA HG F B400 0080

SIGNAL_TYPE : THERMAL (DEGREES-K)

PARAMETER : AMPLITUDE (SAME AS SIGNAL UNITS)

| | | | | | | | | | |
|----|---------------------------|---|---|-------|-------|---------|-------|-------|---|
| 1 | B400 0040 FA TF ---- 0000 | 1 | 2 | 1E+01 | 1E-01 | SECONDS | 1E+01 | 1E+02 | F |
| 2 | B400 0040 WR ER ---- 0000 | 1 | 2 | 1E+00 | 1E-02 | SECONDS | 1E+02 | 1E+02 | F |
| 3 | B400 0080 FA TF ---- 0000 | 1 | 2 | 1E+01 | 1E-01 | SECONDS | 1E+01 | 1E+02 | F |
| 4 | B400 0120 WR ER ---- 0000 | 1 | 2 | 1E+00 | 1E-02 | SECONDS | 1E+02 | 1E+02 | F |
| 5 | B400 0157 FA TF ---- 0000 | 1 | 2 | 1E+01 | 1E-01 | SECONDS | 1E+01 | 1E+02 | F |
| 6 | B400 0080 WR ER ---- 0000 | 1 | 3 | 1E+00 | 1E-02 | SECONDS | 1E+02 | 1E+02 | F |
| 7 | B400 0120 FA TF ---- 0000 | 1 | 3 | 1E+01 | 1E-01 | SECONDS | 1E+01 | 1E+02 | F |
| 8 | B400 0283 FA TF ---- 0000 | 1 | 3 | 1E+01 | 1E-01 | SECONDS | 1E+01 | 1E+02 | F |
| 9 | B400 0080 FA TF ---- 0000 | 1 | 4 | 1E+01 | 1E-01 | SECONDS | 1E+01 | 1E+02 | F |
| 10 | B400 0080 WR ER ---- 0000 | 1 | 4 | 1E+00 | 1E-02 | SECONDS | 1E+02 | 1E+02 | F |

CODE_NUMBER : B400 0820 LQ D2 F B400 0830

SIGNAL_TYPE : THERMAL (DEGREES-K)

PARAMETER : AMPLITUDE (SAME AS SIGNAL UNITS)

| | | | | | | | | | |
|----|---------------------------|---|---|-------|-------|---------|-------|-------|---|
| 1 | B400 0857 FA TF ---- 0000 | 1 | 0 | 1E+01 | 1E-01 | SECONDS | 1E+01 | 1E+02 | F |
| 2 | B400 0860 FA TF ---- 0000 | 1 | 1 | 1E+01 | 1E-01 | SECONDS | 1E+01 | 1E+02 | F |
| 3 | B400 0870 FA TF ---- 0000 | 1 | 1 | 1E+01 | 1E-01 | SECONDS | 1E+01 | 1E+02 | F |
| 4 | B400 0890 FA TF ---- 0000 | 1 | 1 | 1E+01 | 1E-01 | SECONDS | 1E+01 | 1E+02 | F |
| 5 | B400 0800 FA TF ---- 0000 | 1 | 1 | 1E+01 | 1E-01 | SECONDS | 1E+01 | 1E+02 | F |
| 6 | B400 0853 FA TF ---- 0000 | 1 | 1 | 1E+01 | 1E-01 | SECONDS | 1E+01 | 1E+02 | F |
| 7 | B400 0860 FA TF ---- 0000 | 1 | 1 | 1E+01 | 1E-01 | SECONDS | 1E+01 | 1E+02 | F |
| 8 | B400 0865 FA TF ---- 0000 | 1 | 2 | 1E+01 | 1E-01 | SECONDS | 1E+01 | 1E+02 | F |
| 9 | B400 0883 FA TF ---- 0000 | 1 | 2 | 1E+01 | 1E-01 | SECONDS | 1E+01 | 1E+02 | F |
| 10 | B400 0810 FA TF ---- 0000 | 1 | 2 | 1E+01 | 1E-01 | SECONDS | 1E+01 | 1E+02 | F |
| 11 | B400 0833 FA TF ---- 0000 | 1 | 2 | 1E+01 | 1E-01 | SECONDS | 1E+01 | 1E+02 | F |
| 12 | B400 0870 FA TF ---- 0000 | 1 | 2 | 1E+01 | 1E-01 | SECONDS | 1E+01 | 1E+02 | F |
| 13 | B400 0880 FA TF ---- 0000 | 1 | 3 | 1E+01 | 1E-01 | SECONDS | 1E+01 | 1E+02 | F |
| 14 | B400 0820 FA TF ---- 0000 | 1 | 3 | 1E+01 | 1E-01 | SECONDS | 1E+01 | 1E+02 | F |
| 15 | B400 0830 FA TF ---- 0000 | 1 | 3 | 1E+01 | 1E-01 | SECONDS | 1E+01 | 1E+02 | F |

TABLE 18. FAILURE INFORMATION FOR CURRENT INSTRUMENTATION (CONTINUED)

Domain PROPAGATIONS_B400

18-Apr-1987 15:18

| Rec. No. | Failure Mode | Dim. | Sig. Qual. | Max. Freq. Time | Min. Freq. Time | Freq. Time Unit | Sym. Dur. | Pd. Onset | Ind. Fail. |
|--|---------------------------|------|------------|-----------------|-----------------|-----------------|-----------|-----------|------------|
| CODE_NUMBER : B400 0170 GA HG T B400 0180 | | | | | | | | | |
| SIGNAL_TYPE : PRESSURE (PSIA) | | | | | | | | | |
| PARAMETER : AMPLITUDE (SAME AS SIGNAL UNITS) | | | | | | | | | |
| 1 | B400 0180 LK TL ---- 0000 | 1 | 1 | 1E+03 | 1E+00 | HERTZ | 1E+01 | 1E+02 | T |
| 2 | B400 0170 LK TL ---- 0000 | 1 | 2 | 1E+03 | 1E+00 | HERTZ | 1E+01 | 1E+02 | T |
| CODE_NUMBER : B400 0280 GA HE F C200 9910 | | | | | | | | | |
| SIGNAL_TYPE : PRESSURE (PSIA) | | | | | | | | | |
| PARAMETER : AMPLITUDE (SAME AS SIGNAL UNITS) | | | | | | | | | |
| 1 | B400 0220 DF SD ---- 0000 | 1 | 4 | 1E+03 | 1E+00 | HERTZ | 1E+02 | 1E+02 | T |
| 2 | B400 0280 DF SD ---- 0000 | 1 | 4 | 1E+03 | 1E+00 | HERTZ | 1E+02 | 1E+02 | T |
| CODE_NUMBER : B400 0350 LQ D2 F B800 9910 | | | | | | | | | |
| SIGNAL_TYPE : PRESSURE (PSIA) | | | | | | | | | |
| PARAMETER : AMPLITUDE (SAME AS SIGNAL UNITS) | | | | | | | | | |
| 1 | B400 0370 WR CV ---- 0000 | 1 | 0 | 1E+05 | 1E+01 | HERTZ | 1E+02 | 1E+02 | F |
| 2 | B400 0380 WR CV ---- 0000 | 1 | 1 | 1E+05 | 1E+01 | HERTZ | 1E+02 | 1E+02 | F |
| CODE_NUMBER : B400 0380 LQ D2 F B400 0380 | | | | | | | | | |
| SIGNAL_TYPE : PRESSURE (PSIA) | | | | | | | | | |
| PARAMETER : AMPLITUDE (SAME AS SIGNAL UNITS) | | | | | | | | | |
| 1 | B400 0830 FA IP ---- 0000 | 1 | 0 | 1E+02 | 1E-02 | HERTZ | 1E+01 | 1E+01 | F |
| 2 | B400 0380 WR CV ---- 0000 | 1 | 1 | 1E+05 | 1E+01 | HERTZ | 1E+02 | 1E+02 | F |
| 3 | B400 0370 WR CV ---- 0000 | 1 | 3 | 1E+05 | 1E+01 | HERTZ | 1E+02 | 1E+02 | F |
| 4 | B400 0890 FA IP ---- 0000 | 1 | 3 | 1E+02 | 1E-02 | HERTZ | 1E+01 | 1E+01 | F |
| 5 | B400 0380 FA IP ---- 0000 | 1 | 4 | 1E+02 | 1E-02 | HERTZ | 1E+01 | 1E+01 | F |
| CODE_NUMBER : B400 0570 ME CP F B400 0800 | | | | | | | | | |
| SIGNAL_TYPE : VIBRATION (ACCELERATION-G) | | | | | | | | | |
| PARAMETER : AMPLITUDE (SAME AS SIGNAL UNITS) | | | | | | | | | |
| 1 | B400 0070 WR RB B400 0080 | 1 | 0 | 1E+05 | 1E+01 | HERTZ | 1E+01 | 1E+00 | T |
| 2 | B400 0080 FA VF ---- 0000 | 1 | 0 | 1E+04 | 1E+01 | HERTZ | 1E+01 | 1E+01 | F |
| 3 | B400 0120 FA IM ---- 0000 | 1 | 0 | 1E+04 | 1E+01 | HERTZ | 1E-01 | 1E-01 | F |
| 4 | B400 0230 FA VF ---- 0000 | 1 | 0 | 1E+04 | 1E+01 | HERTZ | 1E+02 | 1E+02 | F |
| 5 | B400 0240 FA VF ---- 0000 | 1 | 0 | 1E+04 | 1E+01 | HERTZ | 1E+02 | 1E+02 | F |
| 6 | B400 0270 FA VF ---- 0000 | 1 | 0 | 1E+04 | 1E+01 | HERTZ | 1E+02 | 1E+02 | F |
| 7 | B400 0280 FA VF ---- 0000 | 1 | 0 | 1E+04 | 1E+01 | HERTZ | 1E+02 | 1E+02 | F |
| 8 | B400 0287 FA VF ---- 0000 | 1 | 0 | 1E+04 | 1E+01 | HERTZ | 1E+01 | 1E+02 | F |
| 9 | B400 0287 FI SL ---- 0000 | 1 | 0 | 1E+04 | 1E+01 | HERTZ | 1E+01 | 1E+02 | T |
| 10 | B400 0293 FA VF ---- 0000 | 1 | 0 | 1E+04 | 1E+01 | HERTZ | 1E+01 | 1E+02 | F |
| 11 | B400 0310 FI SL ---- 0000 | 1 | 0 | 1E+04 | 1E+01 | HERTZ | 1E+01 | 1E+02 | T |
| 12 | B400 0330 FA VF ---- 0000 | 1 | 0 | 1E+04 | 1E+01 | HERTZ | 1E+02 | 1E+02 | F |

TABLE 18. FAILURE INFORMATION FOR CURRENT INSTRUMENTATION (CONTINUED)

Domain PROPAGATIONS_B400

16-Apr-1987 15:18

| Rec. No. | Failure Mode | Dim. | Sig. Qual. | Max. Freq. Time | Min. Freq. Time | Freq. Time Unit | Sym. Dur. | Pd. Onset | Ind. Fail. |
|----------|---------------------------|------|------------|-----------------|-----------------|-----------------|-----------|-----------|------------|
| 13 | B400 0330 FI SL ---- 0000 | 1 | 0 | 1E+04 | 1E+01 | HERTZ | 1E+01 | 1E+02 | T |
| 14 | B400 0350 FA VF ---- 0000 | 1 | 0 | 1E+04 | 1E+01 | HERTZ | 1E+02 | 1E+02 | F |
| 15 | B400 0380 FA IM ---- 0000 | 1 | 0 | 1E+04 | 1E+01 | HERTZ | 1E-01 | 1E-01 | F |
| 16 | B400 0380 FA VF ---- 0000 | 1 | 0 | 1E+04 | 1E+01 | HERTZ | 1E+02 | 1E+02 | F |
| 17 | B400 0380 FA VF ---- 0000 | 1 | 0 | 1E+04 | 1E+01 | HERTZ | 1E+02 | 1E+02 | F |
| 18 | B400 0390 FA IM ---- 0000 | 1 | 0 | 1E+04 | 1E+01 | HERTZ | 1E-01 | 1E-01 | F |
| 19 | B400 0540 FA VF ---- 0000 | 1 | 0 | 1E+04 | 1E+01 | HERTZ | 1E+02 | 1E+02 | F |
| 20 | B400 0650 FA VF ---- 0000 | 1 | 0 | 1E+04 | 1E+01 | HERTZ | 1E+02 | 1E+02 | F |
| 21 | B400 0633 FA IM ---- 0000 | 1 | 0 | 1E+04 | 1E+01 | HERTZ | 1E-01 | 1E-01 | F |
| 22 | B400 0657 FA VF ---- 0000 | 1 | 0 | 1E+04 | 1E+01 | HERTZ | 1E+01 | 1E+02 | F |
| 23 | B400 0657 FI SL ---- 0000 | 1 | 0 | 1E+04 | 1E+01 | HERTZ | 1E+01 | 1E+02 | T |
| 24 | B400 0690 WR PT ---- 0000 | 1 | 0 | 1E+07 | 1E+04 | HERTZ | 1E+02 | 1E+02 | T |
| 25 | B400 0690 WR RE ---- 0000 | 1 | 0 | 1E+07 | 1E+04 | HERTZ | 1E+02 | 1E+02 | T |
| 26 | B400 0710 WR PT ---- 0000 | 1 | 0 | 1E+07 | 1E+04 | HERTZ | 1E+02 | 1E+02 | T |
| 27 | B400 0710 WR RE ---- 0000 | 1 | 0 | 1E+07 | 1E+04 | HERTZ | 1E+02 | 1E+02 | T |
| 28 | B400 0720 WR PT ---- 0000 | 1 | 0 | 1E+07 | 1E+04 | HERTZ | 1E+02 | 1E+02 | T |
| 29 | B400 0720 WR RE ---- 0000 | 1 | 0 | 1E+07 | 1E+04 | HERTZ | 1E+02 | 1E+02 | T |
| 30 | B400 0730 WR PT ---- 0000 | 1 | 0 | 1E+07 | 1E+04 | HERTZ | 1E+02 | 1E+02 | T |
| 31 | B400 0730 WR RE ---- 0000 | 1 | 0 | 1E+07 | 1E+04 | HERTZ | 1E+02 | 1E+02 | T |
| 32 | B400 0740 WR PT ---- 0000 | 1 | 0 | 1E+07 | 1E+04 | HERTZ | 1E+02 | 1E+02 | T |
| 33 | B400 0740 WR RE ---- 0000 | 1 | 0 | 1E+07 | 1E+04 | HERTZ | 1E+02 | 1E+02 | T |
| 34 | B400 0750 WR RB B400 0740 | 1 | 0 | 1E+03 | 1E+01 | HERTZ | 1E+02 | 1E+00 | F |
| 35 | B400 0750 WR RB B400 0750 | 1 | 0 | 1E+03 | 1E+01 | HERTZ | 1E+02 | 1E+00 | F |
| 36 | B400 0780 WR PT ---- 0000 | 1 | 0 | 1E+07 | 1E+04 | HERTZ | 1E+02 | 1E+02 | T |
| 37 | B400 0780 WR RE ---- 0000 | 1 | 0 | 1E+07 | 1E+04 | HERTZ | 1E+02 | 1E+02 | T |
| 38 | B400 0080 FA IM ---- 0000 | 1 | 1 | 1E+04 | 1E+01 | HERTZ | 1E-01 | 1E-01 | F |
| 39 | B400 0290 FA VF ---- 0000 | 1 | 1 | 1E+04 | 1E+01 | HERTZ | 1E+02 | 1E+02 | F |
| 40 | B400 0350 FA IM ---- 0000 | 1 | 1 | 1E+04 | 1E+01 | HERTZ | 1E-01 | 1E-01 | F |
| 41 | B400 0380 FA IM ---- 0000 | 1 | 1 | 1E+04 | 1E+01 | HERTZ | 1E-01 | 1E-01 | F |
| 42 | B400 0403 FA VF ---- 0000 | 1 | 1 | 1E+04 | 1E+01 | HERTZ | 1E+01 | 1E+02 | F |
| 43 | B400 0403 FI SL ---- 0000 | 1 | 1 | 1E+04 | 1E+01 | HERTZ | 1E+01 | 1E+02 | T |
| 44 | B400 0550 FI SL ---- 0000 | 1 | 1 | 1E+04 | 1E+01 | HERTZ | 1E+01 | 1E+02 | T |
| 45 | B400 0557 FA VF ---- 0000 | 1 | 1 | 1E+04 | 1E+01 | HERTZ | 1E+01 | 1E+02 | F |
| 46 | B400 0557 FI SL ---- 0000 | 1 | 1 | 1E+04 | 1E+01 | HERTZ | 1E+01 | 1E+02 | T |
| 47 | B400 0583 FA VF ---- 0000 | 1 | 1 | 1E+04 | 1E+01 | HERTZ | 1E+01 | 1E+02 | F |
| 48 | B400 0583 FI SL ---- 0000 | 1 | 1 | 1E+04 | 1E+01 | HERTZ | 1E+01 | 1E+02 | T |
| 49 | B400 0653 FA VF ---- 0000 | 1 | 1 | 1E+04 | 1E+01 | HERTZ | 1E+01 | 1E+02 | F |
| 50 | B400 0653 FI SL ---- 0000 | 1 | 1 | 1E+04 | 1E+01 | HERTZ | 1E+01 | 1E+02 | T |
| 51 | B400 0750 FA VF ---- 0000 | 1 | 1 | 1E+04 | 1E+01 | HERTZ | 1E+02 | 1E+02 | F |
| 52 | B400 0410 FA VF ---- 0000 | 1 | 2 | 1E+04 | 1E+01 | HERTZ | 1E+01 | 1E+01 | T |
| 53 | B400 0590 FA VF ---- 0000 | 1 | 2 | 1E+04 | 1E+01 | HERTZ | 1E+02 | 1E+02 | F |
| 54 | B400 0630 FA VF ---- 0000 | 1 | 2 | 1E+04 | 1E+01 | HERTZ | 1E+02 | 1E+02 | F |
| 55 | B400 0670 WR RB B400 0680 | 1 | 2 | 1E+05 | 1E+01 | HERTZ | 1E+01 | 1E+00 | T |
| 56 | B400 0770 FA VF ---- 0000 | 1 | 2 | 1E+04 | 1E+01 | HERTZ | 1E+02 | 1E+02 | F |
| 57 | B400 0790 FA VF ---- 0000 | 1 | 2 | 1E+04 | 1E+01 | HERTZ | 1E+02 | 1E+02 | F |
| 58 | B400 0790 FI SL ---- 0000 | 1 | 2 | 1E+04 | 1E+01 | HERTZ | 1E+01 | 1E+02 | T |
| 59 | B400 0580 FA VF ---- 0000 | 1 | 3 | 1E+04 | 1E+01 | HERTZ | 1E+02 | 1E+02 | F |
| 60 | B400 0580 FI SL ---- 0000 | 1 | 3 | 1E+04 | 1E+01 | HERTZ | 1E+01 | 1E+02 | T |
| 61 | B400 0585 FA VF ---- 0000 | 1 | 3 | 1E+04 | 1E+01 | HERTZ | 1E+02 | 1E+02 | F |
| 62 | B400 0585 FI SL ---- 0000 | 1 | 3 | 1E+04 | 1E+01 | HERTZ | 1E+01 | 1E+02 | T |
| 63 | B400 0570 FA VF ---- 0000 | 1 | 3 | 1E+04 | 1E+01 | HERTZ | 1E+02 | 1E+02 | F |
| 64 | B400 0580 FA VF ---- 0000 | 1 | 3 | 1E+04 | 1E+01 | HERTZ | 1E+02 | 1E+02 | F |
| 65 | B400 0580 FI SL ---- 0000 | 1 | 3 | 1E+04 | 1E+01 | HERTZ | 1E+01 | 1E+02 | T |

TABLE 18. FAILURE INFORMATION FOR CURRENT INSTRUMENTATION (CONTINUED)

Domain PROPAGATIONS_B400

16-Apr-1987 15:18

| Rec. No. | Failure Mode | Dim. | Sig. Qual. | Max. Freq. Time | Min. Freq. Time | Freq. Unit | Sym. Dur. | Pd. Onset | Ind. Fail. |
|----------|---------------------------|------|------------|-----------------|-----------------|------------|-----------|-----------|------------|
| 66 | B400 0590 FA IM ---- 0000 | 1 | 3 | 1E+04 | 1E+01 | HERTZ | 1E-01 | 1E-01 | F |
| 67 | B400 0600 FA VF ---- 0000 | 1 | 3 | 1E+04 | 1E+01 | HERTZ | 1E+02 | 1E+02 | F |
| 68 | B400 0610 FA VF ---- 0000 | 1 | 3 | 1E+04 | 1E+01 | HERTZ | 1E+02 | 1E+02 | F |
| 69 | B400 0610 FI SL ---- 0000 | 1 | 3 | 1E+04 | 1E+01 | HERTZ | 1E+01 | 1E+02 | T |
| 70 | B400 0620 FA VF ---- 0000 | 1 | 3 | 1E+04 | 1E+01 | HERTZ | 1E+02 | 1E+02 | F |
| 71 | B400 0630 FA IM ---- 0000 | 1 | 3 | 1E+04 | 1E+01 | HERTZ | 1E-01 | 1E-01 | F |
| 72 | B400 0670 WR RB B400 0650 | 1 | 3 | 1E+05 | 1E+01 | HERTZ | 1E+01 | 1E+00 | T |
| 73 | B400 0780 FA VF ---- 0000 | 1 | 3 | 1E+04 | 1E+01 | HERTZ | 1E+02 | 1E+02 | F |
| 74 | B400 0800 FA VF ---- 0000 | 1 | 3 | 1E+04 | 1E+01 | HERTZ | 1E+02 | 1E+02 | F |
| 75 | B400 0800 FI SL ---- 0000 | 1 | 3 | 1E+04 | 1E+01 | HERTZ | 1E+01 | 1E+02 | T |
| 76 | B400 0470 FI BN ---- 0000 | 1 | 4 | 1E+04 | 1E+01 | HERTZ | 1E-01 | 1E-01 | T |
| 77 | B400 0480 FI BN ---- 0000 | 1 | 4 | 1E+04 | 1E+01 | HERTZ | 1E-01 | 1E-01 | T |
| 78 | B400 0600 FA IM ---- 0000 | 1 | 4 | 1E+04 | 1E+01 | HERTZ | 1E-01 | 1E-01 | F |
| 79 | B400 0620 FA IM ---- 0000 | 1 | 4 | 1E+04 | 1E+01 | HERTZ | 1E-01 | 1E-01 | F |
| 80 | B400 0720 FI BN ---- 0000 | 1 | 4 | 1E+04 | 1E+01 | HERTZ | 1E-01 | 1E-01 | T |
| 81 | B400 0730 FI BN ---- 0000 | 1 | 4 | 1E+04 | 1E+01 | HERTZ | 1E-01 | 1E-01 | T |

CODE_NUMBER : B400 0620 LQ 02 F B400 0630

SIGNAL_TYPE : PRESSURE (PSIA)

PARAMETER : AMPLITUDE (SAME AS SIGNAL UNITS)

| | | | | | | | | | |
|---|---------------------------|---|---|-------|-------|-------|-------|-------|---|
| 1 | B400 0590 FA IP ---- 0000 | 1 | 1 | 1E+02 | 1E-02 | HERTZ | 1E+01 | 1E+01 | F |
| 2 | B400 0670 WR CV ---- 0000 | 1 | 1 | 1E+05 | 1E+01 | HERTZ | 1E+02 | 1E+02 | F |
| 3 | B400 0633 FA IP ---- 0000 | 1 | 3 | 1E+02 | 1E-02 | HERTZ | 1E+01 | 1E+00 | F |
| 4 | B400 0630 FA IP ---- 0000 | 1 | 4 | 1E+02 | 1E-02 | HERTZ | 1E+01 | 1E+01 | F |

1. LPOTP Discharge Pressure (HPOTP Pump Inlet)
B400 0350 LQ 02 F B800 9910 PRESSURE

The pressure sensor upstream of the pump may be able to detect cavitation in the pump. An increase in amplitude above 1000 Hz could indicate cavitation. This measurement could be used to trend wear and loads due to cavitation for trending life limits of the affected parts. In conjunction with the discharge pressure and turbine outlet temperature, some determination of the turbopump performance could be made. The performance loss might indicate cavitation, turbine efficiency loss, or other degradation phenomena. It would also help to have flow and temperature information at these points. The pressure sensor can also detect pressure surges that might fracture the ducts upstream of the HPOTP which are not shown on the HPOTP FIPM.

2. HPOTP Discharge Pressure
B400 0380 LQ 02 F B400 0390 PRESSURE

In conjunction with the inlet pressure and turbine outlet temperature, trending of the performance of the pump along with cavitation related failure modes may be possible. Also, pressure surges that might fracture the ducts and cause leaks can be monitored for trending information. A large enough pressure surge might warrant inspection of the ducts during post-flight inspection.

3. Preburner Pump Discharge Pressure
B400 0620 LQ 02 F B400 0630 PRESSURE

Trending of preburner pump cavitation is possible along with monitoring pressure surges that might fracture ducts and manifolds. This measurement may also be helpful in determining overall pump efficiency.

4. Preburner Pump Discharge Temperature
B400 0620 LQ 02 F B400 0630 TEMPERATURE

Can be used for trending information about thermally induced loads on components in the preburner pump. Along with the discharge pressure, some assessment of pump performance can be made. It would also be helpful to have flow information and inlet pressure and flow information. Since the performance of both pumps are related, the inlet

and outlet sensor information from the main pump could be helpful in evaluating performance.

5. HPOTP Turbine Discharge Temperature
A150 9930 GA HG F B400 0080 TEMPERATURE

The turbine exhaust temperature measurement can be used for trending information on the thermal loading and possibly the erosion process for the hot gas section parts. Also may help determine preburner problems which are not a part of this FIPM.

6. HPOTP Secondary Turbine Seal Drain Pressure
B400 0170 GA HG T B400 0180 PRESSURE

This pressure measurement may detect excess leakage in turbine seals which could be critical if hydrogen-rich hot gas mixes with liquid oxygen from the pump-end of the turbopump.

7. HPOTP Intermediate Seal Helium Purge Pressure
B400 0260 GA HE F C200 9910 PRESSURE

This pressure measurement can be used to determine that the proper helium pressure is supplied to the intermediate seal to separate LOX from hydrogen-rich hot gas. High pressure may indicate clogging in the supply line and low pressure might indicate excessive leakage in seals or upstream supply problems. If the helium supply to the seals is cut-off or restricted, a catastrophic failure of the pump would be imminent as hydrogen gas would mix with LOX and into the bearings.

8. HPOTP Radial Accelerometers
B400 0570 ME CP F B400 0600 VIBRATION

The housing accelerometers pick up almost every vibration related failure mode signal in the pump. There is a wealth of information available, but great difficulty in isolating the failure modes. General prognostic monitoring of dynamic loading may be achieved with the accelerometers, but this will not be very precise and will require research into developing a life assessment of each component in relation to the vibration signal and time. Detection of bearing failure modes in the nearby 1st and 2nd bearings may be possible since the accelerometers

are close to the bearings and the signal strength is good. Some seal rubbing failure modes may be detectable since they will produce distinctive spikes in the frequency domain related to the operating RPM of the shaft.

Test Point Analysis for Possible Future Instrumentation

There are several instrumentation concepts under development to monitor for several important failure modes. These failure modes and the instrumentation under development are:

- | | |
|---|---|
| • Bearing faults (wear, pitting, & ball-cage resonance) | Bearing Deflectometer, Isotope Wear, Acoustic Emission Sensor |
| • Turbine blades | Optical Pyrometer |
| • Performance parameters | Shaft Speed Sensor Ultrasonic Flowmeter |

FIPM output of several test points that correspond to these sensors and several other test points that show promise are listed in Table 19 and are analyzed for their potential to monitor various failure modes in the following paragraphs.

TABLE 19. FAILURE INFORMATION FOR POSSIBLE FUTURE INSTRUMENTATION

Domain PROPAGATIONS_B400

22-Apr-1987 15:24

| Rec. No. | Failure Mode | Dim. | Sig. Qual. | Max. Freq. Time | Min. Freq. Time | Freq. Time Unit | Sym. Dur. | Pd. Onset | Ind. Fail. |
|----------|--------------|------|------------|-----------------|-----------------|-----------------|-----------|-----------|------------|
|----------|--------------|------|------------|-----------------|-----------------|-----------------|-----------|-----------|------------|

CODE_NUMBER : B400 0050 ME -- F B400 0140
 SIGNAL_TYPE : THERMAL (DEGREES-K)
 PARAMETER : AMPLITUDE (SAME AS SIGNAL UNITS)

| | | | | | | | | | |
|---|---------------------------|---|---|-------|-------|---------|-------|-------|---|
| 1 | B400 0130 DF SD ---- 0000 | 1 | 1 | 1E+00 | 1E-02 | SECONDS | 1E+02 | 1E+01 | T |
| 2 | B400 0050 FA IM ---- 0000 | 1 | 2 | 1E+05 | 1E+03 | SECONDS | 1E-02 | 1E-02 | T |
| 3 | B400 0050 FA TF ---- 0000 | 1 | 2 | 1E+05 | 1E+03 | SECONDS | 1E+03 | 1E+03 | T |
| 4 | B400 0050 FA VF ---- 0000 | 1 | 2 | 1E+05 | 1E+03 | SECONDS | 1E+03 | 1E+03 | T |

CODE_NUMBER : B400 0050 ME -- F B400 0140
 SIGNAL_TYPE : VIBRATION (ACCELERATION-G)
 PARAMETER : AMPLITUDE (SAME AS SIGNAL UNITS)

| | | | | | | | | | |
|----|---------------------------|---|---|-------|-------|-------|-------|-------|---|
| 1 | B400 0410 WR RB B400 0170 | 1 | 0 | 1E+05 | 1E+01 | HERTZ | 1E+01 | 1E+00 | T |
| 2 | B400 0410 WR RB B400 0180 | 1 | 0 | 1E+05 | 1E+01 | HERTZ | 1E+01 | 1E+00 | T |
| 3 | B400 0410 WR RB B400 0190 | 1 | 0 | 1E+05 | 1E+01 | HERTZ | 1E+01 | 1E+00 | T |
| 4 | B400 0410 WR RB B400 0200 | 1 | 0 | 1E+05 | 1E+01 | HERTZ | 1E+01 | 1E+00 | T |
| 5 | B400 0070 FA IM ---- 0000 | 1 | 1 | 1E+04 | 1E+01 | HERTZ | 1E-01 | 1E-01 | F |
| 6 | B400 0070 WR RB B400 0080 | 1 | 1 | 1E+05 | 1E+01 | HERTZ | 1E+01 | 1E+00 | T |
| 7 | B400 0070 WR RB B400 0080 | 1 | 1 | 1E+05 | 1E+01 | HERTZ | 1E+01 | 1E+00 | T |
| 8 | B400 0180 FA VF ---- 0000 | 1 | 1 | 1E+04 | 1E+01 | HERTZ | 1E+02 | 1E+02 | F |
| 9 | B400 0400 FA IM ---- 0000 | 1 | 1 | 1E+04 | 1E+01 | HERTZ | 1E-01 | 1E-01 | F |
| 10 | B400 0400 WR RB B400 0380 | 1 | 1 | 1E+05 | 1E+01 | HERTZ | 1E+01 | 1E+00 | T |
| 11 | B400 0400 WR RB B400 0370 | 1 | 1 | 1E+05 | 1E+01 | HERTZ | 1E+01 | 1E+00 | T |
| 12 | B400 0440 FA VF ---- 0000 | 1 | 1 | 1E+04 | 1E+01 | HERTZ | 1E+02 | 1E+02 | F |
| 13 | B400 0150 FA VF ---- 0000 | 1 | 2 | 1E+04 | 1E+01 | HERTZ | 1E+02 | 1E+02 | F |
| 14 | B400 0150 WR RB B400 0110 | 1 | 2 | 1E+05 | 1E+01 | HERTZ | 1E+01 | 1E+00 | T |
| 15 | B400 0470 FI BN ---- 0000 | 1 | 2 | 1E+04 | 1E+01 | HERTZ | 1E-01 | 1E-01 | T |
| 16 | B400 0480 FI BN ---- 0000 | 1 | 2 | 1E+04 | 1E+01 | HERTZ | 1E-01 | 1E-01 | T |
| 17 | B400 0720 FI BN ---- 0000 | 1 | 2 | 1E+04 | 1E+01 | HERTZ | 1E-01 | 1E-01 | T |
| 18 | B400 0730 FI BN ---- 0000 | 1 | 2 | 1E+04 | 1E+01 | HERTZ | 1E-01 | 1E-01 | T |
| 19 | B400 0050 FA IM ---- 0000 | 1 | 3 | 1E+04 | 1E+01 | HERTZ | 1E-01 | 1E-01 | F |
| 20 | B400 0140 FA VF ---- 0000 | 1 | 3 | 1E+04 | 1E+01 | HERTZ | 1E+02 | 1E+02 | F |
| 21 | B400 0180 FI SL ---- 0000 | 1 | 3 | 1E+04 | 1E+01 | HERTZ | 1E+01 | 1E+02 | T |
| 22 | B400 0050 WR RB B400 0040 | 1 | 4 | 1E+05 | 1E+01 | HERTZ | 1E+01 | 1E+00 | T |
| 23 | B400 0050 WR RB B400 0080 | 1 | 4 | 1E+05 | 1E+01 | HERTZ | 1E+01 | 1E+00 | T |
| 24 | B400 0410 FA VF ---- 0000 | 1 | 5 | 1E+04 | 1E+01 | HERTZ | 1E+01 | 1E+01 | T |

CODE_NUMBER : B400 0070 ME -- F B400 0150
 SIGNAL_TYPE : THERMAL (DEGREES-K)
 PARAMETER : AMPLITUDE (SAME AS SIGNAL UNITS)

| | | | | | | | | | |
|---|---------------------------|---|---|-------|-------|---------|-------|-------|---|
| 1 | B400 0430 WR PT ---- 0000 | 1 | 0 | 1E+01 | 1E-01 | SECONDS | 1E+01 | 1E+03 | T |
| 2 | B400 0430 WR RE ---- 0000 | 1 | 0 | 1E+01 | 1E-01 | SECONDS | 1E+01 | 1E+03 | T |
| 3 | B400 0450 WR PT ---- 0000 | 1 | 0 | 1E+01 | 1E-01 | SECONDS | 1E+01 | 1E+03 | T |
| 4 | B400 0450 WR RE ---- 0000 | 1 | 0 | 1E+01 | 1E-01 | SECONDS | 1E+01 | 1E+03 | T |
| 5 | B400 0070 FA TF ---- 0000 | 1 | 2 | 1E+05 | 1E+01 | SECONDS | 1E+01 | 1E+02 | T |
| 6 | B400 0070 FA VF ---- 0000 | 1 | 2 | 1E+05 | 1E+03 | SECONDS | 1E+03 | 1E+03 | T |

TABLE 19. FAILURE INFORMATION FOR POSSIBLE FUTURE INSTRUMENTATION (CONTINUED)

Domain PROPAGATIONS_B400

22-Apr-1987 15:24

| Rec. No. | Failure Mode | Dim. | Sig. Qual. | Max. Freq. Time | Min. Freq. Time | Freq. Unit | Sym. Dur. | Pd. Onset | Ind. Fail. |
|----------|--------------|------|------------|-----------------|-----------------|------------|-----------|-----------|------------|
|----------|--------------|------|------------|-----------------|-----------------|------------|-----------|-----------|------------|

CODE_NUMBER : B400 0070 ME -- F B400 0150
 SIGNAL_TYPE : VIBRATION (ACCELERATION-G)
 PARAMETER : AMPLITUDE (SAME AS SIGNAL UNITS)

| | | | | | | | | | |
|----|---------------------------|---|---|-------|-------|-------|-------|-------|---|
| 1 | B400 0050 FA IM ---- 0000 | 1 | 0 | 1E+04 | 1E+01 | HERTZ | 1E-01 | 1E-01 | F |
| 2 | B400 0400 FA VF ---- 0000 | 1 | 0 | 1E+04 | 1E+01 | HERTZ | 1E+04 | 1E+04 | F |
| 3 | B400 0400 WR CV ---- 0000 | 1 | 0 | 1E+05 | 1E+01 | HERTZ | 1E+02 | 1E+02 | F |
| 4 | B400 0430 WR PT ---- 0000 | 1 | 0 | 1E+07 | 1E+04 | HERTZ | 1E+02 | 1E+02 | T |
| 5 | B400 0430 WR RE ---- 0000 | 1 | 0 | 1E+07 | 1E+04 | HERTZ | 1E+02 | 1E+02 | T |
| 6 | B400 0450 WR PT ---- 0000 | 1 | 0 | 1E+07 | 1E+04 | HERTZ | 1E+02 | 1E+02 | T |
| 7 | B400 0450 WR RE ---- 0000 | 1 | 0 | 1E+07 | 1E+04 | HERTZ | 1E+02 | 1E+02 | T |
| 8 | B400 0470 WR PT ---- 0000 | 1 | 0 | 1E+07 | 1E+04 | HERTZ | 1E+02 | 1E+02 | T |
| 9 | B400 0470 WR RE ---- 0000 | 1 | 0 | 1E+07 | 1E+04 | HERTZ | 1E+02 | 1E+02 | T |
| 10 | B400 0480 WR PT ---- 0000 | 1 | 0 | 1E+07 | 1E+04 | HERTZ | 1E+02 | 1E+02 | T |
| 11 | B400 0480 WR RE ---- 0000 | 1 | 0 | 1E+07 | 1E+04 | HERTZ | 1E+02 | 1E+02 | T |
| 12 | B400 0490 WR PT ---- 0000 | 1 | 0 | 1E+07 | 1E+04 | HERTZ | 1E+02 | 1E+02 | T |
| 13 | B400 0490 WR RE ---- 0000 | 1 | 0 | 1E+07 | 1E+04 | HERTZ | 1E+02 | 1E+02 | T |
| 14 | B400 0520 WR PT ---- 0000 | 1 | 0 | 1E+07 | 1E+04 | HERTZ | 1E+02 | 1E+02 | T |
| 15 | B400 0520 WR RE ---- 0000 | 1 | 0 | 1E+07 | 1E+04 | HERTZ | 1E+02 | 1E+02 | T |
| 16 | B400 0050 WR RB B400 0040 | 1 | 1 | 1E+05 | 1E+01 | HERTZ | 1E+01 | 1E+00 | T |
| 17 | B400 0050 WR RB B400 0060 | 1 | 1 | 1E+05 | 1E+01 | HERTZ | 1E+01 | 1E+00 | T |
| 18 | B400 0180 FA VF ---- 0000 | 1 | 1 | 1E+04 | 1E+01 | HERTZ | 1E+02 | 1E+02 | F |
| 19 | B400 0400 WR RB B400 0360 | 1 | 1 | 1E+05 | 1E+01 | HERTZ | 1E+01 | 1E+00 | T |
| 20 | B400 0400 WR RB B400 0370 | 1 | 1 | 1E+05 | 1E+01 | HERTZ | 1E+01 | 1E+00 | T |
| 21 | B400 0440 FA VF ---- 0000 | 1 | 1 | 1E+04 | 1E+01 | HERTZ | 1E+02 | 1E+02 | F |
| 22 | B400 0670 WR RB B400 0650 | 1 | 1 | 1E+05 | 1E+01 | HERTZ | 1E+01 | 1E+00 | T |
| 23 | B400 0670 WR RB B400 0680 | 1 | 1 | 1E+05 | 1E+01 | HERTZ | 1E+01 | 1E+00 | T |
| 24 | B400 0400 FA IM ---- 0000 | 1 | 2 | 1E+04 | 1E+01 | HERTZ | 1E-01 | 1E-01 | F |
| 25 | B400 0410 WR RB B400 0170 | 1 | 2 | 1E+05 | 1E+01 | HERTZ | 1E+01 | 1E+00 | T |
| 26 | B400 0410 WR RB B400 0180 | 1 | 2 | 1E+05 | 1E+01 | HERTZ | 1E+01 | 1E+00 | T |
| 27 | B400 0410 WR RB B400 0190 | 1 | 2 | 1E+05 | 1E+01 | HERTZ | 1E+01 | 1E+00 | T |
| 28 | B400 0410 WR RB B400 0200 | 1 | 2 | 1E+05 | 1E+01 | HERTZ | 1E+01 | 1E+00 | T |
| 29 | B400 0470 FI BN ---- 0000 | 1 | 2 | 1E+04 | 1E+01 | HERTZ | 1E-01 | 1E-01 | T |
| 30 | B400 0480 FI BN ---- 0000 | 1 | 2 | 1E+04 | 1E+01 | HERTZ | 1E-01 | 1E-01 | T |
| 31 | B400 0070 FA IM ---- 0000 | 1 | 3 | 1E+04 | 1E+01 | HERTZ | 1E-01 | 1E-01 | F |
| 32 | B400 0140 FA VF ---- 0000 | 1 | 3 | 1E+04 | 1E+01 | HERTZ | 1E+02 | 1E+02 | F |
| 33 | B400 0150 FA VF ---- 0000 | 1 | 3 | 1E+04 | 1E+01 | HERTZ | 1E+02 | 1E+02 | F |
| 34 | B400 0150 WR RB B400 0110 | 1 | 3 | 1E+05 | 1E+01 | HERTZ | 1E+01 | 1E+00 | T |
| 35 | B400 0180 FI SL ---- 0000 | 1 | 3 | 1E+04 | 1E+01 | HERTZ | 1E+01 | 1E+02 | T |
| 36 | B400 0720 FI BN ---- 0000 | 1 | 3 | 1E+04 | 1E+01 | HERTZ | 1E-01 | 1E-01 | T |
| 37 | B400 0730 FI BN ---- 0000 | 1 | 3 | 1E+04 | 1E+01 | HERTZ | 1E-01 | 1E-01 | T |
| 38 | B400 0070 WR RB B400 0060 | 1 | 4 | 1E+05 | 1E+01 | HERTZ | 1E+01 | 1E+00 | T |
| 39 | B400 0070 WR RB B400 0080 | 1 | 4 | 1E+05 | 1E+01 | HERTZ | 1E+01 | 1E+00 | T |
| 40 | B400 0410 FA VF ---- 0000 | 1 | 5 | 1E+04 | 1E+01 | HERTZ | 1E+01 | 1E+01 | T |

TABLE 19. FAILURE INFORMATION FOR POSSIBLE FUTURE INSTRUMENTATION (CONTINUED)

Domain PROPAGATIONS_B400

21-Apr-1987 20:33

| Rec. No. | Failure Mode | Dim. | Sig. Qual. | Max. Freq. Time | Min. Freq. Time | Freq. Time Unit | Sym. Dur. | Pd. Onset | Ind. Fail. |
|----------|--------------|------|------------|-----------------|-----------------|-----------------|-----------|-----------|------------|
|----------|--------------|------|------------|-----------------|-----------------|-----------------|-----------|-----------|------------|

CODE_NUMBER : B400 0030 GA HG F B400 0040
 SIGNAL_TYPE : THERMAL (DEGREES-K)
 PARAMETER : AMPLITUDE (SAME AS SIGNAL UNITS)

| | | | | | | | | | | | |
|----|-----------------|------|------|---|---|-------|-------|---------|-------|-------|---|
| 1 | B400 0007 FA TF | ---- | 0000 | 1 | 1 | 1E+01 | 1E-01 | SECONDS | 1E+01 | 1E+02 | F |
| 2 | B400 0080 WR ER | ---- | 0000 | 1 | 3 | 1E+00 | 1E-02 | SECONDS | 1E+02 | 1E+02 | F |
| 3 | B400 0120 FA TF | ---- | 0000 | 1 | 3 | 1E+01 | 1E-01 | SECONDS | 1E+01 | 1E+02 | F |
| 4 | B400 0120 WR ER | ---- | 0000 | 1 | 3 | 1E+00 | 1E-02 | SECONDS | 1E+02 | 1E+02 | F |
| 5 | B400 0030 WR ER | ---- | 0000 | 2 | 4 | 1E+00 | 1E-02 | SECONDS | 1E+02 | 1E+02 | F |
| 6 | B400 0040 FA TF | ---- | 0000 | 1 | 4 | 1E+01 | 1E-01 | SECONDS | 1E+01 | 1E+02 | F |
| 7 | B400 0040 WR ER | ---- | 0000 | 1 | 4 | 1E+00 | 1E-02 | SECONDS | 1E+02 | 1E+02 | F |
| 8 | B400 0080 FA TF | ---- | 0000 | 1 | 4 | 1E+01 | 1E-01 | SECONDS | 1E+01 | 1E+02 | F |
| 9 | B400 0080 WR ER | ---- | 0000 | 1 | 4 | 1E+00 | 1E-02 | SECONDS | 1E+02 | 1E+02 | F |
| 10 | B400 0080 FA TF | ---- | 0000 | 1 | 4 | 1E+01 | 1E-01 | SECONDS | 1E+01 | 1E+02 | F |

CODE_NUMBER : B400 0050 GA HG F B400 0060
 SIGNAL_TYPE : THERMAL (DEGREES-K)
 PARAMETER : AMPLITUDE (SAME AS SIGNAL UNITS)

| | | | | | | | | | | | |
|---|-----------------|------|------|---|---|-------|-------|---------|-------|-------|---|
| 1 | B400 0120 FA TF | ---- | 0000 | 1 | 3 | 1E+01 | 1E-01 | SECONDS | 1E+01 | 1E+02 | F |
| 2 | B400 0120 WR ER | ---- | 0000 | 1 | 3 | 1E+00 | 1E-02 | SECONDS | 1E+02 | 1E+02 | F |
| 3 | B400 0040 FA TF | ---- | 0000 | 1 | 4 | 1E+01 | 1E-01 | SECONDS | 1E+01 | 1E+02 | F |
| 4 | B400 0040 WR ER | ---- | 0000 | 1 | 4 | 1E+00 | 1E-02 | SECONDS | 1E+02 | 1E+02 | F |
| 5 | B400 0080 FA TF | ---- | 0000 | 1 | 4 | 1E+01 | 1E-01 | SECONDS | 1E+01 | 1E+02 | F |
| 6 | B400 0080 WR ER | ---- | 0000 | 1 | 4 | 1E+00 | 1E-02 | SECONDS | 1E+02 | 1E+02 | F |
| 7 | B400 0080 FA TF | ---- | 0000 | 1 | 4 | 1E+01 | 1E-01 | SECONDS | 1E+01 | 1E+02 | F |
| 8 | B400 0080 WR ER | ---- | 0000 | 1 | 4 | 1E+00 | 1E-02 | SECONDS | 1E+02 | 1E+02 | F |

CODE_NUMBER : B400 0150 ME CP F B400 0410
 SIGNAL_TYPE : ACOUSTIC (ACOUSTIC EVENTS)
 PARAMETER : AMPLITUDE (SAME AS SIGNAL UNITS)

| | | | | | | | | | | | |
|----|-----------------|------|------|---|---|-------|-------|-------|-------|-------|---|
| 1 | B400 0050 FA IM | ---- | 0000 | 2 | 0 | 1E+07 | 1E+04 | HERTZ | 1E-01 | 1E-01 | T |
| 2 | B400 0050 FA TF | ---- | 0000 | 2 | 0 | 1E+07 | 1E+04 | HERTZ | 1E-01 | 1E+02 | T |
| 3 | B400 0050 FA VF | ---- | 0000 | 2 | 0 | 1E+07 | 1E+05 | HERTZ | 1E-01 | 1E+03 | T |
| 4 | B400 0070 FA IM | ---- | 0000 | 2 | 0 | 1E+07 | 1E+04 | HERTZ | 1E-01 | 1E-01 | T |
| 5 | B400 0070 FA TF | ---- | 0000 | 2 | 0 | 1E+07 | 1E+04 | HERTZ | 1E-01 | 1E+02 | T |
| 6 | B400 0070 FA VF | ---- | 0000 | 2 | 0 | 1E+07 | 1E+05 | HERTZ | 1E-01 | 1E+03 | T |
| 7 | B400 0870 FA IM | ---- | 0000 | 2 | 0 | 1E+07 | 1E+04 | HERTZ | 1E-01 | 1E-01 | T |
| 8 | B400 0870 FA TF | ---- | 0000 | 2 | 0 | 1E+07 | 1E+04 | HERTZ | 1E-01 | 1E+02 | T |
| 9 | B400 0870 FA VF | ---- | 0000 | 2 | 0 | 1E+07 | 1E+04 | HERTZ | 1E-01 | 1E+02 | T |
| 10 | B400 0140 FA TF | ---- | 0000 | 2 | 1 | 1E+07 | 1E+04 | HERTZ | 1E-01 | 1E+02 | T |
| 11 | B400 0140 FA VF | ---- | 0000 | 2 | 1 | 1E+07 | 1E+04 | HERTZ | 1E-01 | 1E+02 | T |
| 12 | B400 0150 FA TF | ---- | 0000 | 2 | 1 | 1E+07 | 1E+04 | HERTZ | 1E-01 | 1E+02 | T |
| 13 | B400 0180 FA TF | ---- | 0000 | 2 | 1 | 1E+07 | 1E+04 | HERTZ | 1E-01 | 1E+02 | T |
| 14 | B400 0180 FA VF | ---- | 0000 | 2 | 1 | 1E+07 | 1E+04 | HERTZ | 1E-01 | 1E+02 | T |
| 15 | B400 0400 FA IM | ---- | 0000 | 2 | 1 | 1E+07 | 1E+04 | HERTZ | 1E-01 | 1E-01 | T |
| 16 | B400 0400 FA TF | ---- | 0000 | 2 | 1 | 1E+07 | 1E+05 | HERTZ | 1E-01 | 1E+02 | T |
| 17 | B400 0400 FA VF | ---- | 0000 | 2 | 1 | 1E+07 | 1E+04 | HERTZ | 1E-01 | 1E+03 | T |

TABLE 19. FAILURE INFORMATION FOR POSSIBLE FUTURE INSTRUMENTATION (CONTINUED)

Domain PROPAGATIONS_B400

21-Apr-1987 20:33

| Rec. No. | Failure Mode | Dim. | Sig. Qual. | Max. Freq. Time | Min. Freq. Time | Freq. Unit | Sym. Dur. | Pd. Onset | Ind. Fail. |
|----------|---------------------------|------|------------|-----------------|-----------------|------------|-----------|-----------|------------|
| 18 | B400 0440 FA VF ---- 0000 | 2 | 1 | 1E+07 | 1E+04 | HERTZ | 1E-01 | 1E+02 | T |
| 19 | B400 0680 FA TF ---- 0000 | 2 | 1 | 1E+07 | 1E+04 | HERTZ | 1E-01 | 1E+02 | T |
| 20 | B400 0680 FA VF ---- 0000 | 2 | 1 | 1E+07 | 1E+04 | HERTZ | 1E-01 | 1E+02 | T |
| 21 | B400 0150 FA VF ---- 0000 | 2 | 2 | 1E+07 | 1E+04 | HERTZ | 1E-01 | 1E+02 | T |
| 22 | B400 0410 FA TF ---- 0000 | 2 | 2 | 1E+07 | 1E+05 | HERTZ | 1E-01 | 1E+02 | T |
| 23 | B400 0410 FA VF ---- 0000 | 2 | 2 | 1E+07 | 1E+04 | HERTZ | 1E-01 | 1E+01 | T |

CODE_NUMBER : B400 0290 ME -- F B400 0650
 SIGNAL_TYPE : ACOUSTIC (ACOUSTIC EVENTS)
 PARAMETER : AMPLITUDE (SAME AS SIGNAL UNITS)

| | | | | | | | | | |
|----|---------------------------|---|---|-------|-------|-------|-------|-------|---|
| 1 | B400 0240 FA VF ---- 0000 | 2 | 0 | 1E+07 | 1E+04 | HERTZ | 1E-01 | 1E+02 | T |
| 2 | B400 0280 FA VF ---- 0000 | 2 | 0 | 1E+07 | 1E+04 | HERTZ | 1E-01 | 1E+02 | T |
| 3 | B400 0287 FA TF ---- 0000 | 2 | 0 | 1E+07 | 1E+04 | HERTZ | 1E-01 | 1E+02 | T |
| 4 | B400 0287 FA VF ---- 0000 | 2 | 0 | 1E+07 | 1E+04 | HERTZ | 1E-01 | 1E+02 | T |
| 5 | B400 0293 FA IP ---- 0000 | 2 | 0 | 1E+07 | 1E+04 | HERTZ | 1E-01 | 1E+00 | T |
| 6 | B400 0293 FA TF ---- 0000 | 2 | 0 | 1E+07 | 1E+04 | HERTZ | 1E-01 | 1E+02 | T |
| 7 | B400 0293 FA VF ---- 0000 | 2 | 0 | 1E+07 | 1E+04 | HERTZ | 1E-01 | 1E+02 | T |
| 8 | B400 0293 LK FA ---- 0000 | 2 | 0 | 1E+07 | 1E+04 | HERTZ | 1E+02 | 1E+02 | T |
| 9 | B400 0293 LK PD ---- 0000 | 2 | 0 | 1E+07 | 1E+04 | HERTZ | 1E+02 | 1E+02 | T |
| 10 | B400 0330 FA VF ---- 0000 | 2 | 0 | 1E+07 | 1E+04 | HERTZ | 1E-01 | 1E+02 | T |
| 11 | B400 0350 FA IM ---- 0000 | 2 | 0 | 1E+07 | 1E+04 | HERTZ | 1E-01 | 1E-01 | T |
| 12 | B400 0350 FA TF ---- 0000 | 2 | 0 | 1E+07 | 1E+04 | HERTZ | 1E-01 | 1E+02 | T |
| 13 | B400 0350 FA VF ---- 0000 | 2 | 0 | 1E+07 | 1E+04 | HERTZ | 1E-01 | 1E+02 | T |
| 14 | B400 0380 FA IM ---- 0000 | 2 | 0 | 1E+07 | 1E+04 | HERTZ | 1E-01 | 1E-01 | T |
| 15 | B400 0380 FA TF ---- 0000 | 2 | 0 | 1E+07 | 1E+04 | HERTZ | 1E-01 | 1E+02 | T |
| 16 | B400 0380 FA VF ---- 0000 | 2 | 0 | 1E+07 | 1E+04 | HERTZ | 1E-01 | 1E+02 | T |
| 17 | B400 0380 FA IM ---- 0000 | 2 | 0 | 1E+07 | 1E+04 | HERTZ | 1E-01 | 1E-01 | T |
| 18 | B400 0500 FA VF ---- 0000 | 2 | 0 | 1E+07 | 1E+04 | HERTZ | 1E-01 | 1E+02 | T |
| 19 | B400 0510 FA VF ---- 0000 | 2 | 0 | 1E+07 | 1E+04 | HERTZ | 1E-01 | 1E+02 | T |
| 20 | B400 0530 FA VF ---- 0000 | 2 | 0 | 1E+07 | 1E+04 | HERTZ | 1E-01 | 1E+02 | T |
| 21 | B400 0600 FA IM ---- 0000 | 2 | 0 | 1E+07 | 1E+04 | HERTZ | 1E-01 | 1E-01 | T |
| 22 | B400 0600 FA TF ---- 0000 | 2 | 0 | 1E+07 | 1E+04 | HERTZ | 1E-01 | 1E+02 | T |
| 23 | B400 0600 FA VF ---- 0000 | 2 | 0 | 1E+07 | 1E+04 | HERTZ | 1E-01 | 1E+02 | T |
| 24 | B400 0620 FA IM ---- 0000 | 2 | 0 | 1E+07 | 1E+04 | HERTZ | 1E-01 | 1E-01 | T |
| 25 | B400 0620 FA TF ---- 0000 | 2 | 0 | 1E+07 | 1E+04 | HERTZ | 1E-01 | 1E+02 | T |
| 26 | B400 0620 FA VF ---- 0000 | 2 | 0 | 1E+07 | 1E+04 | HERTZ | 1E-01 | 1E+02 | T |
| 27 | B400 0540 FA VF ---- 0000 | 2 | 1 | 1E+07 | 1E+04 | HERTZ | 1E-01 | 1E+02 | T |
| 28 | B400 0550 FA VF ---- 0000 | 2 | 1 | 1E+07 | 1E+04 | HERTZ | 1E-01 | 1E+02 | T |
| 29 | B400 0585 FA TF ---- 0000 | 2 | 1 | 1E+07 | 1E+04 | HERTZ | 1E-01 | 1E+02 | T |
| 30 | B400 0585 FA VF ---- 0000 | 2 | 1 | 1E+07 | 1E+04 | HERTZ | 1E-01 | 1E+02 | T |
| 31 | B400 0290 FA TF ---- 0000 | 2 | 2 | 1E+07 | 1E+04 | HERTZ | 1E-01 | 1E+02 | T |
| 32 | B400 0290 FA VF ---- 0000 | 2 | 2 | 1E+07 | 1E+04 | HERTZ | 1E-01 | 1E+02 | T |

CODE_NUMBER : B400 0040 ME -- F B400 0650
 SIGNAL_TYPE : VIBRATION (ACCELERATION-G)
 PARAMETER : AMPLITUDE (SAME AS SIGNAL UNITS)

| | | | | | | | | | |
|---|---------------------------|---|---|-------|-------|-------|-------|-------|---|
| 1 | B400 0040 FA IM ---- 0000 | 1 | 0 | 1E+04 | 1E+01 | HERTZ | 1E-01 | 1E-01 | F |
| 2 | B400 0040 FA VF ---- 0000 | 1 | 0 | 1E+04 | 1E+01 | HERTZ | 1E+01 | 1E+01 | F |
| 3 | B400 0050 WR RB B400 0040 | 1 | 0 | 1E+05 | 1E+01 | HERTZ | 1E+01 | 1E+00 | T |

TABLE 19. FAILURE INFORMATION FOR POSSIBLE FUTURE INSTRUMENTATION (CONTINUED)

Domain PROPAGATIONS_B400

21-Apr-1987 20:33

| Rec. No. | Failure Mode | Dim. | Sig. Qual. | Max. Freq. Time | Min. Freq. Time | Freq. Time Unit | Sym. Dur. | Pd. Onset | Ind. Fail. |
|----------|---------------------------|------|------------|-----------------|-----------------|-----------------|-----------|-----------|------------|
| 4 | B400 0050 WR RB B400 0050 | 1 | 0 | 1E+05 | 1E+01 | HERTZ | 1E+01 | 1E+00 | T |
| 5 | B400 0050 FA IM ---- 0000 | 1 | 0 | 1E+04 | 1E+01 | HERTZ | 1E-01 | 1E-01 | F |
| 6 | B400 0100 FA VF ---- 0000 | 1 | 0 | 1E+04 | 1E+01 | HERTZ | 1E+02 | 1E+02 | F |
| 7 | B400 0120 FA VF ---- 0000 | 1 | 0 | 1E+04 | 1E+01 | HERTZ | 1E+01 | 1E+01 | F |
| 8 | B400 0240 FI SL ---- 0000 | 1 | 0 | 1E+04 | 1E+01 | HERTZ | 1E+01 | 1E+02 | T |
| 9 | B400 0280 FA VF ---- 0000 | 1 | 0 | 1E+04 | 1E+01 | HERTZ | 1E+02 | 1E+02 | F |
| 10 | B400 0380 WR CV ---- 0000 | 1 | 0 | 1E+05 | 1E+01 | HERTZ | 1E+01 | 1E+02 | F |
| 11 | B400 0370 FA VF ---- 0000 | 1 | 0 | 1E+04 | 1E+01 | HERTZ | 1E+02 | 1E+02 | F |
| 12 | B400 0370 WR CV ---- 0000 | 1 | 0 | 1E+05 | 1E+01 | HERTZ | 1E+02 | 1E+02 | F |
| 13 | B400 0380 FA VF ---- 0000 | 1 | 0 | 1E+04 | 1E+01 | HERTZ | 1E+02 | 1E+02 | F |
| 14 | B400 0400 FA IM ---- 0000 | 1 | 0 | 1E+04 | 1E+01 | HERTZ | 1E-01 | 1E-01 | F |
| 15 | B400 0400 WR CV ---- 0000 | 1 | 0 | 1E+05 | 1E+01 | HERTZ | 1E+02 | 1E+02 | F |
| 16 | B400 0400 WR RB B400 0380 | 1 | 0 | 1E+05 | 1E+01 | HERTZ | 1E+01 | 1E+00 | T |
| 17 | B400 0430 WR PT ---- 0000 | 1 | 0 | 1E+07 | 1E+04 | HERTZ | 1E+02 | 1E+02 | T |
| 18 | B400 0430 WR RE ---- 0000 | 1 | 0 | 1E+07 | 1E+04 | HERTZ | 1E+02 | 1E+02 | T |
| 19 | B400 0450 WR PT ---- 0000 | 1 | 0 | 1E+07 | 1E+04 | HERTZ | 1E+02 | 1E+02 | T |
| 20 | B400 0450 WR RE ---- 0000 | 1 | 0 | 1E+07 | 1E+04 | HERTZ | 1E+02 | 1E+02 | T |
| 21 | B400 0470 WR PT ---- 0000 | 1 | 0 | 1E+07 | 1E+04 | HERTZ | 1E+02 | 1E+02 | T |
| 22 | B400 0470 WR RE ---- 0000 | 1 | 0 | 1E+07 | 1E+04 | HERTZ | 1E+02 | 1E+02 | T |
| 23 | B400 0480 WR PT ---- 0000 | 1 | 0 | 1E+07 | 1E+04 | HERTZ | 1E+02 | 1E+02 | T |
| 24 | B400 0480 WR RE ---- 0000 | 1 | 0 | 1E+07 | 1E+04 | HERTZ | 1E+02 | 1E+02 | T |
| 25 | B400 0490 WR PT ---- 0000 | 1 | 0 | 1E+07 | 1E+04 | HERTZ | 1E+02 | 1E+02 | T |
| 26 | B400 0490 WR RE ---- 0000 | 1 | 0 | 1E+07 | 1E+04 | HERTZ | 1E+02 | 1E+02 | T |
| 27 | B400 0500 WR RB B400 0490 | 1 | 0 | 1E+03 | 1E+01 | HERTZ | 1E+02 | 1E+00 | T |
| 28 | B400 0510 WR RB B400 0520 | 1 | 0 | 1E+03 | 1E+01 | HERTZ | 1E+02 | 1E+00 | T |
| 29 | B400 0520 WR PT ---- 0000 | 1 | 0 | 1E+07 | 1E+04 | HERTZ | 1E+02 | 1E+02 | T |
| 30 | B400 0520 WR RE ---- 0000 | 1 | 0 | 1E+07 | 1E+04 | HERTZ | 1E+02 | 1E+02 | T |
| 31 | B400 0590 FA VF ---- 0000 | 1 | 0 | 1E+04 | 1E+01 | HERTZ | 1E+02 | 1E+02 | F |
| 32 | B400 0630 FA VF ---- 0000 | 1 | 0 | 1E+04 | 1E+01 | HERTZ | 1E+02 | 1E+02 | F |
| 33 | B400 0670 WR RB B400 0680 | 1 | 0 | 1E+05 | 1E+01 | HERTZ | 1E+01 | 1E+00 | T |
| 34 | B400 0770 FA VF ---- 0000 | 1 | 0 | 1E+04 | 1E+01 | HERTZ | 1E+02 | 1E+02 | F |
| 35 | B400 0790 FA VF ---- 0000 | 1 | 0 | 1E+04 | 1E+01 | HERTZ | 1E+02 | 1E+02 | F |
| 36 | B400 0790 FI SL ---- 0000 | 1 | 0 | 1E+04 | 1E+01 | HERTZ | 1E+01 | 1E+02 | T |
| 37 | B400 0060 FA VF ---- 0000 | 1 | 1 | 1E+04 | 1E+01 | HERTZ | 1E+01 | 1E+01 | F |
| 38 | B400 0070 WR RB B400 0080 | 1 | 1 | 1E+05 | 1E+01 | HERTZ | 1E+01 | 1E+00 | T |
| 39 | B400 0120 FA IM ---- 0000 | 1 | 1 | 1E+04 | 1E+01 | HERTZ | 1E-01 | 1E-01 | F |
| 40 | B400 0210 FA VF ---- 0000 | 1 | 1 | 1E+04 | 1E+01 | HERTZ | 1E+02 | 1E+02 | F |
| 41 | B400 0230 FA VF ---- 0000 | 1 | 1 | 1E+04 | 1E+01 | HERTZ | 1E+02 | 1E+02 | F |
| 42 | B400 0250 FA VF ---- 0000 | 1 | 1 | 1E+04 | 1E+01 | HERTZ | 1E+02 | 1E+02 | F |
| 43 | B400 0250 FI SL ---- 0000 | 1 | 1 | 1E+04 | 1E+01 | HERTZ | 1E+01 | 1E+02 | T |
| 44 | B400 0270 FA VF ---- 0000 | 1 | 1 | 1E+04 | 1E+01 | HERTZ | 1E+02 | 1E+02 | F |
| 45 | B400 0270 FI SL ---- 0000 | 1 | 1 | 1E+04 | 1E+01 | HERTZ | 1E+01 | 1E+02 | T |
| 46 | B400 0287 FA VF ---- 0000 | 1 | 1 | 1E+04 | 1E+01 | HERTZ | 1E+01 | 1E+02 | F |
| 47 | B400 0287 FI SL ---- 0000 | 1 | 1 | 1E+04 | 1E+01 | HERTZ | 1E+01 | 1E+02 | T |
| 48 | B400 0293 FA VF ---- 0000 | 1 | 1 | 1E+04 | 1E+01 | HERTZ | 1E+01 | 1E+02 | F |
| 49 | B400 0310 FI SL ---- 0000 | 1 | 1 | 1E+04 | 1E+01 | HERTZ | 1E+01 | 1E+02 | T |
| 50 | B400 0320 FA VF ---- 0000 | 1 | 1 | 1E+04 | 1E+01 | HERTZ | 1E+02 | 1E+02 | F |
| 51 | B400 0320 FI SL ---- 0000 | 1 | 1 | 1E+04 | 1E+01 | HERTZ | 1E+01 | 1E+02 | T |
| 52 | B400 0330 FA VF ---- 0000 | 1 | 1 | 1E+04 | 1E+01 | HERTZ | 1E+02 | 1E+02 | F |
| 53 | B400 0330 FI SL ---- 0000 | 1 | 1 | 1E+04 | 1E+01 | HERTZ | 1E+01 | 1E+02 | T |
| 54 | B400 0380 FA IM ---- 0000 | 1 | 1 | 1E+04 | 1E+01 | HERTZ | 1E-01 | 1E-01 | F |
| 55 | B400 0380 FA VF ---- 0000 | 1 | 1 | 1E+04 | 1E+01 | HERTZ | 1E+02 | 1E+02 | F |
| 56 | B400 0380 FA VF ---- 0000 | 1 | 1 | 1E+04 | 1E+01 | HERTZ | 1E+02 | 1E+02 | F |

TABLE 19. FAILURE INFORMATION FOR POSSIBLE FUTURE INSTRUMENTATION (CONTINUED)

Domain PROPAGATIONS_B400

21-Apr-1987 20:33

| Rec. No. | Failure Mode | Dia. | Sig. Qual. | Max. Freq. Time | Min. Freq. Time | Freq. Time Unit | Sym. Dur. | Pd. Onset | Ind. Fail. |
|----------|---------------------------|------|------------|-----------------|-----------------|-----------------|-----------|-----------|------------|
| 57 | B400 0380 FA IM ---- 0000 | 1 | 1 | 1E+04 | 1E+01 | HERTZ | 1E-01 | 1E-01 | F |
| 58 | B400 0410 WR RB B400 0200 | 1 | 1 | 1E+05 | 1E+01 | HERTZ | 1E+01 | 1E+00 | T |
| 59 | B400 0500 FA VF ---- 0000 | 1 | 1 | 1E+04 | 1E+01 | HERTZ | 1E+02 | 1E+02 | F |
| 60 | B400 0510 FA VF ---- 0000 | 1 | 1 | 1E+04 | 1E+01 | HERTZ | 1E+02 | 1E+02 | F |
| 61 | B400 0580 FA VF ---- 0000 | 1 | 1 | 1E+04 | 1E+01 | HERTZ | 1E+02 | 1E+02 | F |
| 62 | B400 0580 FI SL ---- 0000 | 1 | 1 | 1E+04 | 1E+01 | HERTZ | 1E+01 | 1E+02 | T |
| 63 | B400 0570 FA VF ---- 0000 | 1 | 1 | 1E+04 | 1E+01 | HERTZ | 1E+02 | 1E+02 | F |
| 64 | B400 0580 FA VF ---- 0000 | 1 | 1 | 1E+04 | 1E+01 | HERTZ | 1E+02 | 1E+02 | F |
| 65 | B400 0580 FI SL ---- 0000 | 1 | 1 | 1E+04 | 1E+01 | HERTZ | 1E+01 | 1E+02 | T |
| 66 | B400 0590 FA IM ---- 0000 | 1 | 1 | 1E+04 | 1E+01 | HERTZ | 1E-01 | 1E-01 | F |
| 67 | B400 0800 FA VF ---- 0000 | 1 | 1 | 1E+04 | 1E+01 | HERTZ | 1E+02 | 1E+02 | F |
| 68 | B400 0810 FA VF ---- 0000 | 1 | 1 | 1E+04 | 1E+01 | HERTZ | 1E+02 | 1E+02 | F |
| 69 | B400 0810 FI SL ---- 0000 | 1 | 1 | 1E+04 | 1E+01 | HERTZ | 1E+01 | 1E+02 | T |
| 70 | B400 0820 FA VF ---- 0000 | 1 | 1 | 1E+04 | 1E+01 | HERTZ | 1E+02 | 1E+02 | F |
| 71 | B400 0830 FA IM ---- 0000 | 1 | 1 | 1E+04 | 1E+01 | HERTZ | 1E-01 | 1E-01 | F |
| 72 | B400 0870 WR RB B400 0850 | 1 | 1 | 1E+05 | 1E+01 | HERTZ | 1E+01 | 1E+00 | T |
| 73 | B400 0780 FA VF ---- 0000 | 1 | 1 | 1E+04 | 1E+01 | HERTZ | 1E+02 | 1E+02 | F |
| 74 | B400 0800 FA VF ---- 0000 | 1 | 1 | 1E+04 | 1E+01 | HERTZ | 1E+02 | 1E+02 | F |
| 75 | B400 0800 FI SL ---- 0000 | 1 | 1 | 1E+04 | 1E+01 | HERTZ | 1E+01 | 1E+02 | T |
| 76 | B400 0070 WR RB B400 0080 | 1 | 2 | 1E+05 | 1E+01 | HERTZ | 1E+01 | 1E+00 | T |
| 77 | B400 0080 FA IM ---- 0000 | 1 | 2 | 1E+04 | 1E+01 | HERTZ | 1E-01 | 1E-01 | F |
| 78 | B400 0080 FA VF ---- 0000 | 1 | 2 | 1E+04 | 1E+01 | HERTZ | 1E+01 | 1E+01 | F |
| 79 | B400 0240 FA VF ---- 0000 | 1 | 2 | 1E+04 | 1E+01 | HERTZ | 1E+02 | 1E+02 | F |
| 80 | B400 0310 FA VF ---- 0000 | 1 | 2 | 1E+04 | 1E+01 | HERTZ | 1E+02 | 1E+02 | F |
| 81 | B400 0380 FA VF ---- 0000 | 1 | 2 | 1E+04 | 1E+01 | HERTZ | 1E+02 | 1E+02 | F |
| 82 | B400 0380 FA IM ---- 0000 | 1 | 2 | 1E+04 | 1E+01 | HERTZ | 1E-01 | 1E-01 | F |
| 83 | B400 0530 FA VF ---- 0000 | 1 | 2 | 1E+04 | 1E+01 | HERTZ | 1E+02 | 1E+02 | F |
| 84 | B400 0540 FA VF ---- 0000 | 1 | 2 | 1E+04 | 1E+01 | HERTZ | 1E+02 | 1E+02 | F |
| 85 | B400 0585 FA VF ---- 0000 | 1 | 2 | 1E+04 | 1E+01 | HERTZ | 1E+02 | 1E+02 | F |
| 86 | B400 0800 FA IM ---- 0000 | 1 | 2 | 1E+04 | 1E+01 | HERTZ | 1E-01 | 1E-01 | F |
| 87 | B400 0820 FA IM ---- 0000 | 1 | 2 | 1E+04 | 1E+01 | HERTZ | 1E-01 | 1E-01 | F |
| 88 | B400 0720 FI BN ---- 0000 | 1 | 2 | 1E+04 | 1E+01 | HERTZ | 1E-01 | 1E-01 | T |
| 89 | B400 0730 FI BN ---- 0000 | 1 | 2 | 1E+04 | 1E+01 | HERTZ | 1E-01 | 1E-01 | T |
| 90 | B400 0280 FA VF ---- 0000 | 1 | 3 | 1E+04 | 1E+01 | HERTZ | 1E+02 | 1E+02 | F |
| 91 | B400 0380 FA IM ---- 0000 | 1 | 3 | 1E+04 | 1E+01 | HERTZ | 1E-01 | 1E-01 | F |
| 92 | B400 0410 FA VF ---- 0000 | 1 | 3 | 1E+04 | 1E+01 | HERTZ | 1E+01 | 1E+01 | T |
| 93 | B400 0580 FA VF ---- 0000 | 1 | 3 | 1E+04 | 1E+01 | HERTZ | 1E+02 | 1E+02 | F |
| 94 | B400 0585 FI SL ---- 0000 | 1 | 3 | 1E+04 | 1E+01 | HERTZ | 1E+01 | 1E+02 | T |
| 95 | B400 0470 FI BN ---- 0000 | 1 | 4 | 1E+04 | 1E+01 | HERTZ | 1E-01 | 1E-01 | T |
| 96 | B400 0480 FI BN ---- 0000 | 1 | 4 | 1E+04 | 1E+01 | HERTZ | 1E-01 | 1E-01 | T |
| 97 | B400 0580 FI SL ---- 0000 | 1 | 4 | 1E+04 | 1E+01 | HERTZ | 1E+01 | 1E+02 | T |

CODE_NUMBER : B400 0380 LQ 02 F B400 0380

SIGNAL_TYPE : FLOW (LB-MASS PER SECOND)

PARAMETER : AMPLITUDE (SAME AS SIGNAL UNITS)

| | | | | | | | | | |
|---|---------------------------|---|---|-------|-------|-------|-------|-------|---|
| 1 | B400 0380 WR CV ---- 0000 | 1 | 0 | 1E+05 | 1E+01 | HERTZ | 1E+02 | 1E+02 | F |
| 2 | B400 0370 WR CV ---- 0000 | 1 | 1 | 1E+05 | 1E+01 | HERTZ | 1E+02 | 1E+02 | F |

TABLE 19. FAILURE INFORMATION FOR POSSIBLE FUTURE INSTRUMENTATION (CONTINUED)

Domain PROPAGATIONS_B400

21-Apr-1987 20:33

| Rec. No. | Failure Mode | Dim. | Sig. Qual. | Max. Freq. Time | Min. Freq. Time | Freq. Time Unit | Sym. Dur. | Pd. Onset | Ind. Fail. |
|----------|--------------|------|------------|-----------------|-----------------|-----------------|-----------|-----------|------------|
|----------|--------------|------|------------|-----------------|-----------------|-----------------|-----------|-----------|------------|

CODE_NUMBER : B400 0410 ME -- F B400 0680
 SIGNAL_TYPE : RPM (RPM)
 PARAMETER : AMPLITUDE (SAME AS SIGNAL UNITS)

| | | | | | | | | | |
|---|---------------------------|---|---|-------|-------|-------|-------|-------|---|
| 1 | B400 0050 WR RB B400 0040 | 1 | 3 | 1E+04 | 1E+00 | HERTZ | 1E+02 | 1E+00 | T |
| 2 | B400 0050 WR RB B400 0060 | 1 | 3 | 1E+04 | 1E+00 | HERTZ | 1E+02 | 1E+00 | T |
| 3 | B400 0070 WR RB B400 0080 | 1 | 3 | 1E+04 | 1E+00 | HERTZ | 1E+02 | 1E+00 | T |
| 4 | B400 0070 WR RB B400 0080 | 1 | 3 | 1E+04 | 1E+00 | HERTZ | 1E+02 | 1E+00 | T |
| 5 | B400 0670 WR RB B400 0650 | 1 | 3 | 1E+04 | 1E+00 | HERTZ | 1E+02 | 1E+00 | T |
| 6 | B400 0670 WR RB B400 0680 | 1 | 3 | 1E+04 | 1E+00 | HERTZ | 1E+02 | 1E+00 | T |
| 7 | B400 0150 WR RB B400 0110 | 1 | 4 | 1E+04 | 1E+00 | HERTZ | 1E+02 | 1E+00 | T |

CODE_NUMBER : B400 0410 ME -- F B400 0680
 SIGNAL_TYPE : RPM (RPM)
 PARAMETER : FREQUENCY (HERTZ)

| | | | | | | | | | |
|---|---------------------------|---|---|-------|-------|-------|-------|-------|---|
| 1 | B400 0410 WR RB B400 0170 | 1 | 5 | 1E+03 | 1E+02 | HERTZ | 1E+02 | 1E+00 | T |
| 2 | B400 0410 WR RB B400 0180 | 1 | 5 | 1E+03 | 1E+02 | HERTZ | 1E+02 | 1E+00 | T |
| 3 | B400 0410 WR RB B400 0190 | 1 | 5 | 1E+03 | 1E+02 | HERTZ | 1E+02 | 1E+00 | T |
| 4 | B400 0410 WR RB B400 0200 | 1 | 5 | 1E+03 | 1E+02 | HERTZ | 1E+02 | 1E+00 | T |

CODE_NUMBER : B400 0410 ME -- F B400 0680
 SIGNAL_TYPE : VIBRATION (ACCELERATION-G)
 PARAMETER : AMPLITUDE (SAME AS SIGNAL UNITS)

| | | | | | | | | | |
|----|---------------------------|---|---|-------|-------|-------|-------|-------|---|
| 1 | B400 0070 FA IM ---- 0000 | 1 | 0 | 1E+04 | 1E+01 | HERTZ | 1E-01 | 1E-01 | F |
| 2 | B400 0430 WR RE ---- 0000 | 1 | 0 | 1E+07 | 1E+04 | HERTZ | 1E+02 | 1E+02 | T |
| 3 | B400 0450 WR RE ---- 0000 | 1 | 0 | 1E+07 | 1E+04 | HERTZ | 1E+02 | 1E+02 | T |
| 4 | B400 0470 WR PT ---- 0000 | 1 | 0 | 1E+07 | 1E+04 | HERTZ | 1E+02 | 1E+02 | T |
| 5 | B400 0470 WR RE ---- 0000 | 1 | 0 | 1E+07 | 1E+04 | HERTZ | 1E+02 | 1E+02 | T |
| 6 | B400 0480 WR PT ---- 0000 | 1 | 0 | 1E+07 | 1E+04 | HERTZ | 1E+02 | 1E+02 | T |
| 7 | B400 0480 WR RE ---- 0000 | 1 | 0 | 1E+07 | 1E+04 | HERTZ | 1E+02 | 1E+02 | T |
| 8 | B400 0490 WR PT ---- 0000 | 1 | 0 | 1E+07 | 1E+04 | HERTZ | 1E+02 | 1E+02 | T |
| 9 | B400 0490 WR RE ---- 0000 | 1 | 0 | 1E+07 | 1E+04 | HERTZ | 1E+02 | 1E+02 | T |
| 10 | B400 0520 WR PT ---- 0000 | 1 | 0 | 1E+07 | 1E+04 | HERTZ | 1E+02 | 1E+02 | T |
| 11 | B400 0520 WR RE ---- 0000 | 1 | 0 | 1E+07 | 1E+04 | HERTZ | 1E+02 | 1E+02 | T |
| 12 | B400 0690 WR PT ---- 0000 | 1 | 0 | 1E+07 | 1E+04 | HERTZ | 1E+02 | 1E+02 | T |
| 13 | B400 0690 WR RE ---- 0000 | 1 | 0 | 1E+07 | 1E+04 | HERTZ | 1E+02 | 1E+02 | T |
| 14 | B400 0710 WR PT ---- 0000 | 1 | 0 | 1E+07 | 1E+04 | HERTZ | 1E+02 | 1E+02 | T |
| 15 | B400 0710 WR RE ---- 0000 | 1 | 0 | 1E+07 | 1E+04 | HERTZ | 1E+02 | 1E+02 | T |
| 16 | B400 0720 WR PT ---- 0000 | 1 | 0 | 1E+07 | 1E+04 | HERTZ | 1E+02 | 1E+02 | T |
| 17 | B400 0720 WR RE ---- 0000 | 1 | 0 | 1E+07 | 1E+04 | HERTZ | 1E+02 | 1E+02 | T |
| 18 | B400 0730 WR PT ---- 0000 | 1 | 0 | 1E+07 | 1E+04 | HERTZ | 1E+02 | 1E+02 | T |
| 19 | B400 0730 WR RE ---- 0000 | 1 | 0 | 1E+07 | 1E+04 | HERTZ | 1E+02 | 1E+02 | T |
| 20 | B400 0740 WR PT ---- 0000 | 1 | 0 | 1E+07 | 1E+04 | HERTZ | 1E+02 | 1E+02 | T |
| 21 | B400 0740 WR RE ---- 0000 | 1 | 0 | 1E+07 | 1E+04 | HERTZ | 1E+02 | 1E+02 | T |
| 22 | B400 0780 WR PT ---- 0000 | 1 | 0 | 1E+07 | 1E+04 | HERTZ | 1E+02 | 1E+02 | T |
| 23 | B400 0780 WR RE ---- 0000 | 1 | 0 | 1E+07 | 1E+04 | HERTZ | 1E+02 | 1E+02 | T |
| 24 | B400 0050 WR RB B400 0040 | 1 | 1 | 1E+05 | 1E+01 | HERTZ | 1E+01 | 1E+00 | T |

TABLE 19. FAILURE INFORMATION FOR POSSIBLE FUTURE INSTRUMENTATION (CONTINUED)

Domain PROPAGATIONS_B400

21-Apr-1987 20:33

| Rec. No. | Failure Mode | Dim. | Sig. Qual. | Max. Freq. Time | Min. Freq. Time | Freq. Time Unit | Sym. Dur. | Pd. Onset | Ind. Fail. |
|----------|---------------------------|------|------------|-----------------|-----------------|-----------------|-----------|-----------|------------|
| 25 | B400 0050 WR RB B400 0080 | 1 | 1 | 1E+05 | 1E+01 | HERTZ | 1E+01 | 1E+00 | T |
| 26 | B400 0070 WR RB B400 0080 | 1 | 1 | 1E+05 | 1E+01 | HERTZ | 1E+01 | 1E+00 | T |
| 27 | B400 0070 WR RB B400 0080 | 1 | 1 | 1E+05 | 1E+01 | HERTZ | 1E+01 | 1E+00 | T |
| 28 | B400 0400 FA VF ---- 0000 | 1 | 1 | 1E+04 | 1E+01 | HERTZ | 1E+04 | 1E+04 | F |
| 29 | B400 0400 WR CV ---- 0000 | 1 | 1 | 1E+05 | 1E+01 | HERTZ | 1E+02 | 1E+02 | F |
| 30 | B400 0430 WR PT ---- 0000 | 1 | 1 | 1E+07 | 1E+04 | HERTZ | 1E+02 | 1E+02 | T |
| 31 | B400 0450 WR PT ---- 0000 | 1 | 1 | 1E+07 | 1E+04 | HERTZ | 1E+02 | 1E+02 | T |
| 32 | B400 0700 FA VF ---- 0000 | 1 | 1 | 1E+04 | 1E+01 | HERTZ | 1E+02 | 1E+02 | F |
| 33 | B400 0140 FA VF ---- 0000 | 1 | 2 | 1E+04 | 1E+01 | HERTZ | 1E+02 | 1E+02 | F |
| 34 | B400 0150 FA VF ---- 0000 | 1 | 2 | 1E+04 | 1E+01 | HERTZ | 1E+02 | 1E+02 | F |
| 35 | B400 0150 WR RB B400 0110 | 1 | 2 | 1E+05 | 1E+01 | HERTZ | 1E+01 | 1E+00 | T |
| 36 | B400 0180 FA VF ---- 0000 | 1 | 2 | 1E+04 | 1E+01 | HERTZ | 1E+02 | 1E+02 | F |
| 37 | B400 0180 FI SL ---- 0000 | 1 | 2 | 1E+04 | 1E+01 | HERTZ | 1E+01 | 1E+02 | T |
| 38 | B400 0400 WR RB B400 0380 | 1 | 2 | 1E+05 | 1E+01 | HERTZ | 1E+01 | 1E+00 | T |
| 39 | B400 0400 WR RB B400 0370 | 1 | 2 | 1E+05 | 1E+01 | HERTZ | 1E+01 | 1E+00 | T |
| 40 | B400 0440 FA VF ---- 0000 | 1 | 2 | 1E+04 | 1E+01 | HERTZ | 1E+02 | 1E+02 | F |
| 41 | B400 0670 FA VF ---- 0000 | 1 | 2 | 1E+04 | 1E+01 | HERTZ | 1E+02 | 1E+02 | F |
| 42 | B400 0670 WR CV ---- 0000 | 1 | 2 | 1E+05 | 1E+01 | HERTZ | 1E+02 | 1E+02 | F |
| 43 | B400 0400 FA IM ---- 0000 | 1 | 3 | 1E+04 | 1E+01 | HERTZ | 1E-01 | 1E-01 | F |
| 44 | B400 0880 FA VF ---- 0000 | 1 | 3 | 1E+04 | 1E+01 | HERTZ | 1E+02 | 1E+02 | F |
| 45 | B400 0880 FI SL ---- 0000 | 1 | 3 | 1E+04 | 1E+01 | HERTZ | 1E+01 | 1E+02 | T |
| 46 | B400 0670 FA IM ---- 0000 | 1 | 3 | 1E+04 | 1E+01 | HERTZ | 1E-01 | 1E-01 | F |
| 47 | B400 0670 WR RB B400 0850 | 1 | 3 | 1E+05 | 1E+01 | HERTZ | 1E+01 | 1E+00 | T |
| 48 | B400 0670 WR RB B400 0880 | 1 | 3 | 1E+05 | 1E+01 | HERTZ | 1E+01 | 1E+00 | T |
| 49 | B400 0410 WR RB B400 0170 | 1 | 4 | 1E+05 | 1E+01 | HERTZ | 1E+01 | 1E+00 | T |
| 50 | B400 0410 WR RB B400 0180 | 1 | 4 | 1E+05 | 1E+01 | HERTZ | 1E+01 | 1E+00 | T |
| 51 | B400 0410 WR RB B400 0190 | 1 | 4 | 1E+05 | 1E+01 | HERTZ | 1E+01 | 1E+00 | T |
| 52 | B400 0410 WR RB B400 0200 | 1 | 4 | 1E+05 | 1E+01 | HERTZ | 1E+01 | 1E+00 | T |
| 53 | B400 0410 FA VF ---- 0000 | 1 | 5 | 1E+04 | 1E+01 | HERTZ | 1E+01 | 1E+01 | T |
| 54 | B400 0470 FI BN ---- 0000 | 1 | 5 | 1E+04 | 1E+01 | HERTZ | 1E-01 | 1E-01 | T |
| 55 | B400 0480 FI BN ---- 0000 | 1 | 5 | 1E+04 | 1E+01 | HERTZ | 1E-01 | 1E-01 | T |
| 56 | B400 0720 FI BN ---- 0000 | 1 | 5 | 1E+04 | 1E+01 | HERTZ | 1E-01 | 1E-01 | T |
| 57 | B400 0730 FI BN ---- 0000 | 1 | 5 | 1E+04 | 1E+01 | HERTZ | 1E-01 | 1E-01 | T |

CODE_NUMBER : B400 0520 ME -- F B400 0530
 SIGNAL_TYPE : ACOUSTIC (ACOUSTIC EVENTS)
 PARAMETER : AMPLITUDE (SAME AS SIGNAL UNITS)

| | | | | | | | | | |
|---|---------------------------|---|---|-------|-------|-------|-------|-------|---|
| 1 | B400 0500 FA VF ---- 0000 | 2 | 0 | 1E+07 | 1E+04 | HERTZ | 1E-01 | 1E+02 | T |
| 2 | B400 0510 FA VF ---- 0000 | 2 | 1 | 1E+07 | 1E+04 | HERTZ | 1E-01 | 1E+02 | T |
| 3 | B400 0530 FA VF ---- 0000 | 2 | 1 | 1E+07 | 1E+04 | HERTZ | 1E-01 | 1E+02 | T |

CODE_NUMBER : B400 0520 ME -- F B400 0530
 SIGNAL_TYPE : VIBRATION (ACCELERATION-G)
 PARAMETER : AMPLITUDE (SAME AS SIGNAL UNITS)

| | | | | | | | | | |
|---|---------------------------|---|---|-------|-------|-------|-------|-------|---|
| 1 | B400 0240 FA VF ---- 0000 | 1 | 0 | 1E+04 | 1E+01 | HERTZ | 1E+02 | 1E+02 | F |
| 2 | B400 0290 FA VF ---- 0000 | 1 | 0 | 1E+04 | 1E+01 | HERTZ | 1E+02 | 1E+02 | F |
| 3 | B400 0350 FA IM ---- 0000 | 1 | 0 | 1E+04 | 1E+01 | HERTZ | 1E-01 | 1E-01 | F |
| 4 | B400 0500 WR RB B400 0480 | 1 | 0 | 1E+03 | 1E+01 | HERTZ | 1E+02 | 1E+00 | T |
| 5 | B400 0540 FA VF ---- 0000 | 1 | 0 | 1E+04 | 1E+01 | HERTZ | 1E+02 | 1E+02 | F |

TABLE 19. FAILURE INFORMATION FOR POSSIBLE FUTURE INSTRUMENTATION (CONTINUED)

Domain PROPAGATIONS_B400

21-Apr-1987 20:33

| Rec. No. | Failure Mode | Dim. | Sig. Qual. | Max. Freq. Time | Min. Freq. Time | Freq. Time Unit | Sym. Dur. | Pd. Onset | Ind. Fail. |
|----------|---------------------------|------|------------|-----------------|-----------------|-----------------|-----------|-----------|------------|
| 6 | B400 0585 FI SL ---- 0000 | 1 | 0 | 1E+04 | 1E+01 | HERTZ | 1E+01 | 1E+02 | T |
| 7 | B400 0720 FI BN ---- 0000 | 1 | 0 | 1E+04 | 1E+01 | HERTZ | 1E-01 | 1E-01 | T |
| 8 | B400 0730 FI BN ---- 0000 | 1 | 0 | 1E+04 | 1E+01 | HERTZ | 1E-01 | 1E-01 | T |
| 9 | B400 0280 FA VF ---- 0000 | 1 | 1 | 1E+04 | 1E+01 | HERTZ | 1E+02 | 1E+02 | F |
| 10 | B400 0400 FA IM ---- 0000 | 1 | 1 | 1E+04 | 1E+01 | HERTZ | 1E-01 | 1E-01 | F |
| 11 | B400 0480 FA VF ---- 0000 | 1 | 1 | 1E+05 | 1E+01 | HERTZ | 1E+01 | 1E+01 | F |
| 12 | B400 0510 WR RB B400 0520 | 1 | 1 | 1E+03 | 1E+01 | HERTZ | 1E+02 | 1E+00 | T |
| 13 | B400 0550 FA VF ---- 0000 | 1 | 1 | 1E+04 | 1E+01 | HERTZ | 1E+02 | 1E+02 | F |
| 14 | B400 0410 FA VF ---- 0000 | 1 | 2 | 1E+04 | 1E+01 | HERTZ | 1E+01 | 1E+01 | T |
| 15 | B400 0430 WR PT ---- 0000 | 1 | 2 | 1E+07 | 1E+04 | HERTZ | 1E+02 | 1E+02 | T |
| 16 | B400 0430 WR RE ---- 0000 | 1 | 2 | 1E+07 | 1E+04 | HERTZ | 1E+02 | 1E+02 | T |
| 17 | B400 0470 WR PT ---- 0000 | 1 | 2 | 1E+07 | 1E+04 | HERTZ | 1E+02 | 1E+02 | T |
| 18 | B400 0470 WR RE ---- 0000 | 1 | 2 | 1E+07 | 1E+04 | HERTZ | 1E+02 | 1E+02 | T |
| 19 | B400 0490 WR PT ---- 0000 | 1 | 2 | 1E+07 | 1E+04 | HERTZ | 1E+02 | 1E+02 | T |
| 20 | B400 0490 WR RE ---- 0000 | 1 | 2 | 1E+07 | 1E+04 | HERTZ | 1E+02 | 1E+02 | T |
| 21 | B400 0500 FA VF ---- 0000 | 1 | 2 | 1E+04 | 1E+01 | HERTZ | 1E+02 | 1E+02 | F |
| 22 | B400 0450 WR PT ---- 0000 | 1 | 3 | 1E+07 | 1E+04 | HERTZ | 1E+02 | 1E+02 | T |
| 23 | B400 0450 WR RE ---- 0000 | 1 | 3 | 1E+07 | 1E+04 | HERTZ | 1E+02 | 1E+02 | T |
| 24 | B400 0480 WR PT ---- 0000 | 1 | 3 | 1E+07 | 1E+04 | HERTZ | 1E+02 | 1E+02 | T |
| 25 | B400 0480 WR RE ---- 0000 | 1 | 3 | 1E+07 | 1E+04 | HERTZ | 1E+02 | 1E+02 | T |
| 26 | B400 0510 FA VF ---- 0000 | 1 | 3 | 1E+04 | 1E+01 | HERTZ | 1E+02 | 1E+02 | F |
| 27 | B400 0520 WR PT ---- 0000 | 1 | 3 | 1E+07 | 1E+04 | HERTZ | 1E+02 | 1E+02 | T |
| 28 | B400 0520 WR RE ---- 0000 | 1 | 3 | 1E+07 | 1E+04 | HERTZ | 1E+02 | 1E+02 | T |
| 29 | B400 0530 FA VF ---- 0000 | 1 | 3 | 1E+04 | 1E+01 | HERTZ | 1E+02 | 1E+02 | F |
| 30 | B400 0550 FI SL ---- 0000 | 1 | 3 | 1E+04 | 1E+01 | HERTZ | 1E+01 | 1E+02 | T |
| 31 | B400 0470 FI BN ---- 0000 | 1 | 4 | 1E+04 | 1E+01 | HERTZ | 1E-01 | 1E-01 | T |
| 32 | B400 0480 FI BN ---- 0000 | 1 | 4 | 1E+04 | 1E+01 | HERTZ | 1E-01 | 1E-01 | T |

CODE_NUMBER : B400 0770 ME -- F B400 0790
 SIGNAL_TYPE : ACOUSTIC (ACOUSTIC EVENTS)
 PARAMETER : AMPLITUDE (SAME AS SIGNAL UNITS)

| | | | | | | | | | |
|---|---------------------------|---|---|-------|-------|-------|-------|-------|---|
| 1 | B400 0750 FA VF ---- 0000 | 2 | 1 | 1E+07 | 1E+04 | HERTZ | 1E-01 | 1E+02 | T |
| 2 | B400 0780 FA VF ---- 0000 | 2 | 1 | 1E+07 | 1E+04 | HERTZ | 1E-01 | 1E+02 | T |
| 3 | B400 0800 FA VF ---- 0000 | 2 | 1 | 1E+07 | 1E+04 | HERTZ | 1E-01 | 1E+02 | T |
| 4 | B400 0770 FA VF ---- 0000 | 2 | 2 | 1E+07 | 1E+04 | HERTZ | 1E-01 | 1E+02 | T |
| 5 | B400 0790 FA VF ---- 0000 | 2 | 2 | 1E+07 | 1E+04 | HERTZ | 1E-01 | 1E+02 | T |

CODE_NUMBER : B400 0770 ME -- F B400 0790
 SIGNAL_TYPE : VIBRATION (ACCELERATION-G)
 PARAMETER : AMPLITUDE (SAME AS SIGNAL UNITS)

| | | | | | | | | | |
|---|---------------------------|---|---|-------|-------|-------|-------|-------|---|
| 1 | B400 0470 FI BN ---- 0000 | 1 | 0 | 1E+04 | 1E+01 | HERTZ | 1E-01 | 1E-01 | T |
| 2 | B400 0480 FI BN ---- 0000 | 1 | 0 | 1E+04 | 1E+01 | HERTZ | 1E-01 | 1E-01 | T |
| 3 | B400 0570 FA VF ---- 0000 | 1 | 0 | 1E+04 | 1E+01 | HERTZ | 1E+02 | 1E+02 | F |
| 4 | B400 0600 FA VF ---- 0000 | 1 | 0 | 1E+04 | 1E+01 | HERTZ | 1E+02 | 1E+02 | F |
| 5 | B400 0620 FA VF ---- 0000 | 1 | 0 | 1E+04 | 1E+01 | HERTZ | 1E+02 | 1E+02 | F |
| 6 | B400 0680 FI SL ---- 0000 | 1 | 0 | 1E+04 | 1E+01 | HERTZ | 1E+01 | 1E+02 | T |
| 7 | B400 0670 WR RB B400 0650 | 1 | 0 | 1E+05 | 1E+01 | HERTZ | 1E+01 | 1E+00 | T |
| 8 | B400 0720 FA VF ---- 0000 | 1 | 0 | 1E+05 | 1E+01 | HERTZ | 1E+01 | 1E+01 | F |
| 9 | B400 0730 FA VF ---- 0000 | 1 | 0 | 1E+05 | 1E+01 | HERTZ | 1E+01 | 1E+01 | F |

TABLE 19. FAILURE INFORMATION FOR POSSIBLE FUTURE INSTRUMENTATION (CONTINUED)

Domain PROPAGATIONS_B400

21-Apr-1987 20:33

| Rec. No. | Failure Mode | Dim. | Sig. Qual. | Max. Freq. Time | Min. Freq. Time | Freq. Unit | Sym. Dur. | Pd. Onset | Ind. Fail. |
|----------|---------------------------|------|------------|-----------------|-----------------|------------|-----------|-----------|------------|
| 10 | B400 0750 WR RB B400 0740 | 1 | 1 | 1E+03 | 1E+01 | HERTZ | 1E+02 | 1E+00 | F |
| 11 | B400 0750 WR RB B400 0780 | 1 | 1 | 1E+03 | 1E+01 | HERTZ | 1E+02 | 1E+00 | F |
| 12 | B400 0870 WR RB B400 0880 | 1 | 2 | 1E+05 | 1E+01 | HERTZ | 1E+01 | 1E+00 | T |
| 13 | B400 0890 WR PT ---- 0000 | 1 | 2 | 1E+07 | 1E+04 | HERTZ | 1E+02 | 1E+02 | T |
| 14 | B400 0890 WR RE ---- 0000 | 1 | 2 | 1E+07 | 1E+04 | HERTZ | 1E+02 | 1E+02 | T |
| 15 | B400 0710 WR PT ---- 0000 | 1 | 2 | 1E+07 | 1E+04 | HERTZ | 1E+02 | 1E+02 | T |
| 16 | B400 0710 WR RE ---- 0000 | 1 | 2 | 1E+07 | 1E+04 | HERTZ | 1E+02 | 1E+02 | T |
| 17 | B400 0720 WR PT ---- 0000 | 1 | 2 | 1E+07 | 1E+04 | HERTZ | 1E+02 | 1E+02 | T |
| 18 | B400 0720 WR RE ---- 0000 | 1 | 2 | 1E+07 | 1E+04 | HERTZ | 1E+02 | 1E+02 | T |
| 19 | B400 0730 WR PT ---- 0000 | 1 | 2 | 1E+07 | 1E+04 | HERTZ | 1E+02 | 1E+02 | T |
| 20 | B400 0730 WR RE ---- 0000 | 1 | 2 | 1E+07 | 1E+04 | HERTZ | 1E+02 | 1E+02 | T |
| 21 | B400 0740 WR PT ---- 0000 | 1 | 2 | 1E+07 | 1E+04 | HERTZ | 1E+02 | 1E+02 | T |
| 22 | B400 0740 WR RE ---- 0000 | 1 | 2 | 1E+07 | 1E+04 | HERTZ | 1E+02 | 1E+02 | T |
| 23 | B400 0750 FA VF ---- 0000 | 1 | 2 | 1E+04 | 1E+01 | HERTZ | 1E+02 | 1E+02 | F |
| 24 | B400 0780 WR PT ---- 0000 | 1 | 2 | 1E+07 | 1E+04 | HERTZ | 1E+02 | 1E+02 | T |
| 25 | B400 0780 WR RE ---- 0000 | 1 | 2 | 1E+07 | 1E+04 | HERTZ | 1E+02 | 1E+02 | T |
| 26 | B400 0800 FA VF ---- 0000 | 1 | 2 | 1E+04 | 1E+01 | HERTZ | 1E+02 | 1E+02 | F |
| 27 | B400 0800 FI SL ---- 0000 | 1 | 2 | 1E+04 | 1E+01 | HERTZ | 1E+01 | 1E+02 | T |
| 28 | B400 0410 FA VF ---- 0000 | 1 | 3 | 1E+04 | 1E+01 | HERTZ | 1E+01 | 1E+01 | T |
| 29 | B400 0770 FA VF ---- 0000 | 1 | 3 | 1E+04 | 1E+01 | HERTZ | 1E+02 | 1E+02 | F |
| 30 | B400 0780 FA VF ---- 0000 | 1 | 3 | 1E+04 | 1E+01 | HERTZ | 1E+02 | 1E+02 | F |
| 31 | B400 0790 FA VF ---- 0000 | 1 | 3 | 1E+04 | 1E+01 | HERTZ | 1E+02 | 1E+02 | F |
| 32 | B400 0790 FI SL ---- 0000 | 1 | 3 | 1E+04 | 1E+01 | HERTZ | 1E+01 | 1E+02 | T |
| 33 | B400 0720 FI BN ---- 0000 | 1 | 4 | 1E+04 | 1E+01 | HERTZ | 1E-01 | 1E-01 | T |
| 34 | B400 0730 FI BN ---- 0000 | 1 | 4 | 1E+04 | 1E+01 | HERTZ | 1E-01 | 1E-01 | T |

1. Bearing Fault Detection

B400 0520 ME -- F B400 0530 VIBRATION
B400 0550 ME -- F B400 0290 VIBRATION
B400 0770 ME -- F B400 0790 VIBRATION

At the first connection (Bearing #3 outer race), the signal from bearing #3 failure modes is very strong in the high frequency range. The only other high frequency information is from fracture-generated acoustic signals (see same connection with parameter - ACOUSTIC), but are a lower signal level than the bearing fault signals. The second connection, where Bearings #3 and #4 support block mounts to the pump housing, shows that signals from both bearings can be detected, but the signal levels are much lower and fracture-generated acoustic signals from nearby parts are at the same signal level or higher. This would make it difficult to extract the bearing failure information from that of other components except for the ball-cage resonance type failure, denoted by the FI BN (Friction-Binding) failure mode. The ball-cage resonance failure mode from all the bearings can be readily detected at the second location. The third location, near bearings #1 and #2 spring isolator, shows the capability of detection all the failure modes of these two bearings.

2. Turbine Blade Fracture Detection

B400 0050 ME -- F B400 0140 THERMAL
B400 0070 ME -- F B400 0150 THERMAL

There are two major failure modes an optical pyrometer can detect and isolate. In looking at the FIPM output for a thermal signal type, fracture of the blades and lack of coolant flow to the rotor from the coolant nozzle ring can be detected. The frequency response of the pyrometer must be very high to measure a temperature profile of each blade as it passes. To detect the lack of coolant flow to the rotor, a long term increase in the RMS value of the temperature is required for detection and isolation. The optical pyrometer could be very useful in reducing the inspection time of the turbine blades. To detect fractures in the 1st (0050) and 2nd (0070) stage turbine blades would require two pyrometers. The only other method of turbine blade crack detection would require an acoustic emission sensor mounted in the shaft or rotor to detect fracture propagation. This method has two problems. First, the signal must be transmitted from the shaft to the housing by telemetry and

second, the influence of other fracture failure modes would mean that two sensors would be required to locate the fracture acoustic signal by the difference in arrival time between each transducer mounted at different locations.

3. Shaft Speed Sensor (RPM)

B400 0410 ME -- F B400 0660 RPM, VIBRATION

There is ongoing development to add a shaft speed sensor to the HPOTP which can be used for pump performance, but also may be an excellent method to detect rubbing failure modes. The sensor being developed uses four magnets imbedded concentrically in a nut fastened to the shaft. As the components rub, instead of a steady sine wave signal, there will be glitches in the time domain signal, which should show up as sidebands of 4X the RPM frequency. Another non-intrusive method to measure turbopump RPM is using an ultrasonic doppler technique to detect the impeller blade passage. The ultrasonic doppler transducer method may also detect bearing problems and imbalance problems (same location, but with parameter-VIBRATION), since it may detect shaft vibration at much higher frequencies than the shaft RPM. This transducer might not be able to isolate the individual failure mode for each part, but could be effective in discriminating specific classes of failure modes, such as wear by rubbing, wear by cavitation, bearing faults, fracture by impact, and vibration fatigue trending. At any of the above test points, shaft imbalance (B400 0410 FA VF) caused failures is detectable. The best detection position for this failure mode is the shaft using the ultrasonic doppler transducer mounted to the pump housing. This the shaft imbalance would be characterized by a sharp peak in the frequency domain at the shaft RPM frequency, slightly less than the shaft RPM frequency, or multiples of the RPM frequency.

4. HPOTP Pump Outlet Flow - Ultrasonic Flowmeter

B400 0380 LQ 02 F B400 0390 FLOW

Other than flow information for monitoring and control of system performance, high frequency information might be useful in detection of pump cavitation.

(This page intentionally blank)

HPOTP ACCELEROMETER DATA REVIEW

The high amplitude signals at 2X cage frequency found in the data from the HPOTP radial accelerometers during tests 7500283 and 7500284 are consistent with the results of the cage instability study conducted by Battelle several years ago (Reference 8). The 2X cage frequency signal is typical of a marginally stable, marginally unstable, or unstable cage. A high-frequency signal above 4 kHz would be indicative of an unstable case only. The 2X frequency was picked up very easily by the pump radial accelerometers and could easily be used for diagnostic monitoring of the bearing cage instability problem. There is not much noise in this region of the frequency spectrum, and a peak for an extended period of time could be used trend for inspection of the bearings or even shutdown of the engine if the high-frequency information is detected. Detection of signals at both frequencies would give a two-level indication of an imminent failure. The high-frequency data was not shown on any of the plots reviewed, so it was difficult to determine if the cage resonance was only marginally stable or unstable. The force required to cause structural failure of the cage would easily be produced by a very unstable case and might be produced by a marginally stable case according to the same analytical study.

The analytical study mentioned above used a Battelle-developed computer code called BASDAP to determine the sensitivity of cage instability to various design parameters and the resulting affect on the structural integrity of the race. The conclusions and recommendations from this study are included in Appendix C. The 2X cage frequency (approximately 450 Hz) can be seen in the plot in Figure 60 of the relative angular displacement of the cage versus time. This is a marginally stable case where the cage is moving back and forth relative to the balls and impacting them. In this case, there is just enough energy dissipated in the system for the oscillation to slowly die out and prevent an unstable condition. The amplitude is high enough to cause relatively high impact forces on the cage. In a completely unstable case shown in Figure 61, the 2X cage frequency is superimposed on the high-frequency instability in the time domain. Therefore, energy at 2X indicates at least there is a marginally unstable environment, but energy at much

higher frequencies (above 4 kHz) must be detected to verify a completely unstable case.

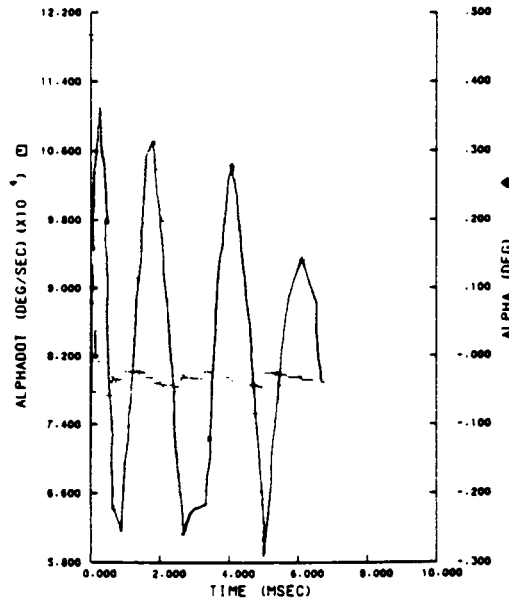

FIGURE 60. IMPACT OF CAGE AND BALLS AT APPROXIMATELY 450 HZ. CALCULATED BY BASDAP FOR A MARGINALLY STABLE CASE (Reference 8)

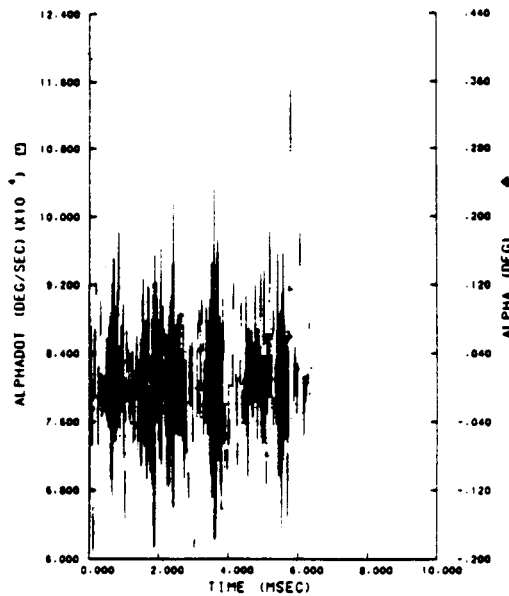

FIGURE 61. HIGH-FREQUENCY CAGE INSTABILITY WITH 2X FREQUENCY SUPERIMPOSED. CALCULATED BY BASDAP (Reference 8)

The HPOTP radial accelerometer data for tests 7500283 and 7500284, plotted in the frequency domain at 3.6 second intervals, shows predominant peaks at 2X cage frequency (about 430 Hz) and smaller peaks at 1X, 3x, and 4X cage frequency. The 2X peak can clearly be seen in the plot in Figure 62 at 265.2 seconds into test 7500283. These peaks suddenly disappear about 200 seconds into test 7500284 as seen in the waterfall plot in Figure 63. At this point the cage has probably disintegrated and the test ended at 309 seconds. Upon examination of the bearings, the cage was gone and pieces were found in the MOV downstream of the pump. The bearings were worn in excess of 15 mils and if the test ran much longer, the balls would probably have been thrown out of the races and the turbopump would quickly be destroyed and most likely take out the whole engine.

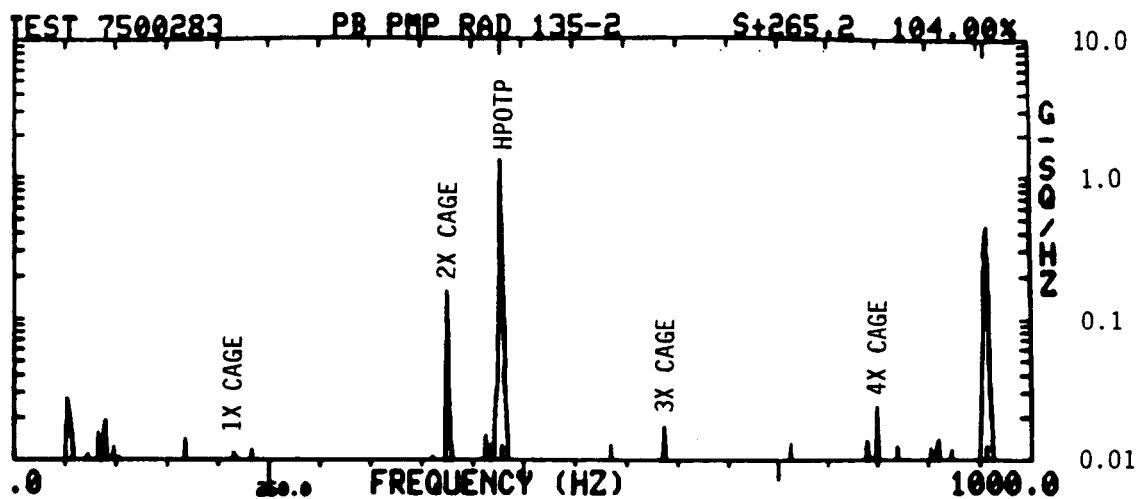

FIGURE 62. TEST 7500283 HPOTP RADIAL ACCELEROMETER 135° FREQUENCY VERSUS ACCELERATION PLOT AT 265.2 SECONDS

TEST 7500284 PB PMP RAD 45-1 (28- 7) 050187
TIME INC= 3.6 SEC XINC=100. (HZ) MAX= 15.8 LOG/25. X
BW= 50. 1300.

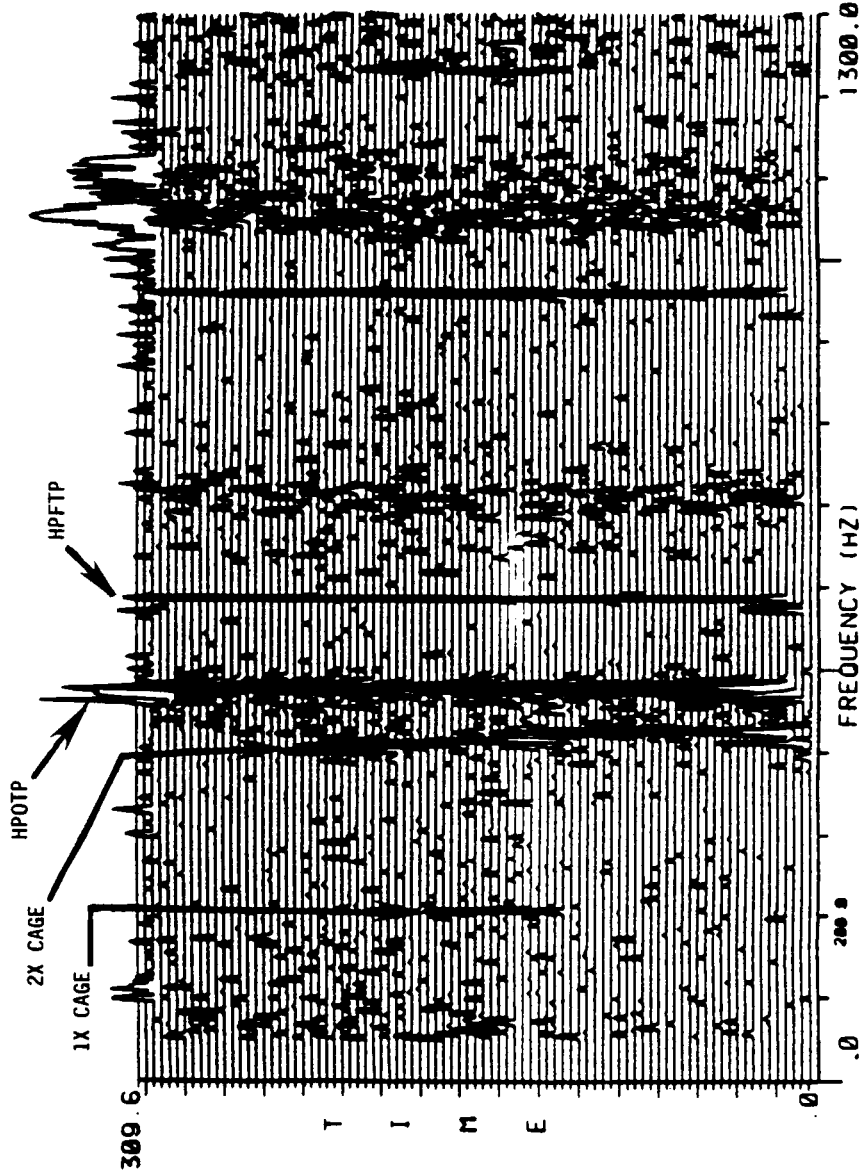

FIGURE 63. TEST 7500284 HPOTP PREBURNER PUMP RADIAL ACCELEROMETER 45° SPECTRAL MAPS SHOWING 1X AND 2X CAGE FREQUENCY PEAKS

2X cage frequency was evident in HPOTP 4101 during tests 902-409 through -410. This problem does not seem to be an isolated incident. The bearings are run at very high speed with poor lubrication and are very prone to a cage instability failure mode. Detection with the preburner pump radial accelerometers looks quite feasible. In discussions with Mr. Preston Jones at NASA MSFC, the accelerometer signal has a bandpass filter with cutoff frequencies of 50 and 2500 Hz. The accelerometer is capable of measuring signals above 10 kHz and some of the recent data has shown signals in the 3500 to 6000 frequency range that could be evidence of a cage instability problem. Unfortunately, all the plots we have currently are from 50 top 1300 Hz.

This is the first time a particular failure mode has been detected by the pump housing accelerometers. The housing accelerometer data has been examined for indications of bearing defects for some time without much success. A recent study on detection of power plant axial-flow fan (Reference 9) shows that the most effective frequency band to monitor for bearing faults and wear is in the 30 to 60 kHz range as seen in Figure 64. Detection in the lower frequency range is difficult, because energy input from other sources, such as rotordynamic effects. In most cases, the bearing had to have sustained major damage to be detectable at frequencies under 15kHz for these large roller bearings in the fans. Since the recorder is only capable of measuring below 20 kHz and much of the signal from bearing defects can be above 20 kHz, it is not surprising that information on the bearing condition could not be obtained from the accelerometer data. Since the accelerometer has a resonance at approximately 30kHz and may provide useful information to 60 kHz, bearing condition information could possibly be detected by extending the data recording capabilities. The resonance could be used for increased sensitivity in this frequency range or impedance compensation could be provided to flatten the frequency response curve of the accelerometer.

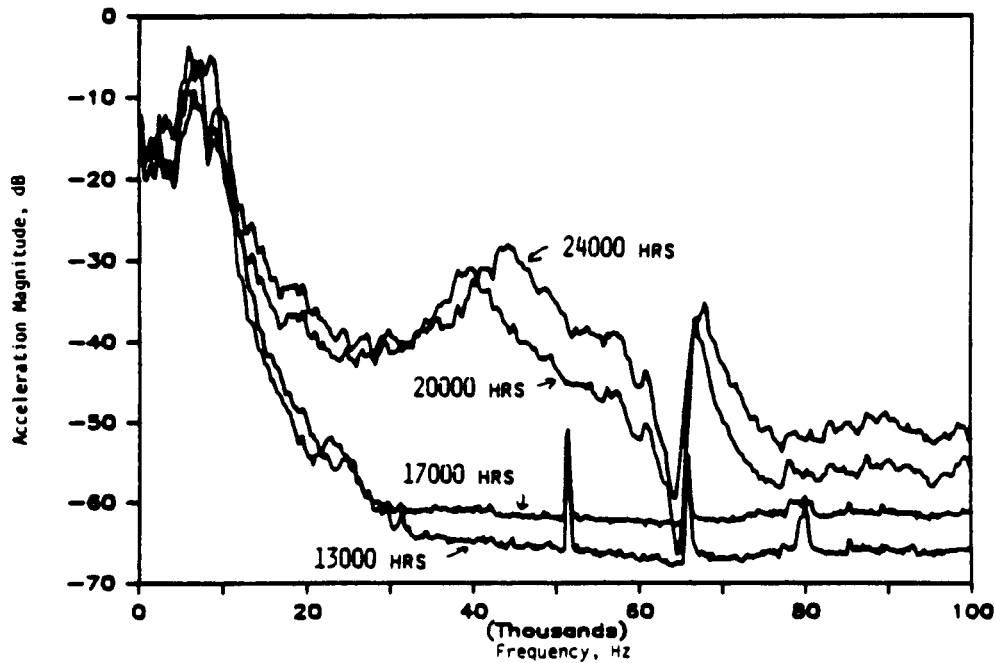

FIGURE 64. VIBRATION SPECTRAL DATA FOR THE BEARING SERVICE LIFE IN A POWER PLANT AXIAL-FLOW FAN. (REFERENCE 9)

In conclusion, the bearing cage instability analysis results correlate with findings from the pump accelerometer data analysis on the recent tests. Since the bearings operate at such high speeds with poor lubrication, diagnostic monitoring of this problem should be considered. The data analysis from these two tests indicates that the present accelerometers can be useful in monitoring of this failure mode and possibly other bearing faults, such as race and ball defects. It will require more extensive analysis and data recording capabilities up to 50 kHz with the present accelerometers.

Recommendations for further testing to determine the pump housing accelerometers capability as a diagnostic/monitoring tool are:

- Remove the 2.5 kHz low pass filter for some of the tests
- Increase recording capabilities on ground tests to well above the 30kHz resonant frequency of the accelerometers.

- When evidence of cage instability or bearing defects occur, remove and examine that bearings post-test for validation of the measurements.

(This page intentionally blank).

ON-BOARD CONDITION MONITORING

Any changes to the SSME condition monitoring system used on board the Space Shuttle must be carefully studied in terms of the overall impact on engine and vehicle systems. The primary item involved from the engine perspective is the controller. On the vehicle side, changes to the SSME diagnostic system could affect the Orbiter telemetry and recording systems. Relatively minor changes to the system could have wide-ranging implications depending on the reserve capability associated with these other systems. This task reviewed the various elements of the current on-board condition monitoring system and evaluated the potential impacts associated with possible changes to the SSME monitoring approach.

SSME Controller

As described in Reference 6, the controller operates in conjunction with the engine sensors, valves, actuators, and ignitors to provide self-contained engine control, checkout, and monitoring. A controller is mounted on each of the three SSMEs. The controller provides the following six functions:

- On-board checkout
- Engine start readiness verification
- Engine sequencing (start & shutdown)
- Closed-loop engine control
- Engine limit monitoring
- Acquisition of engine maintenance data.

The controller samples sensor outputs and updates instructions to the SSME every 20 milliseconds. The controller uses a dual redundant design which allows normal operation after the first failure and fail-safe shutdown after a second failure.

The controller is functionally divided into five subsystems each of which is fully redundant. These subsystems include: 1) input electronics, 2) output electronics, 3) computer interface electronics, 4)

digital computer, and 5) power supply electronics. The controller organization is shown in Figure 65. The primary subsystems involved in condition monitoring are the input electronics, the computer interface electronics, and the digital computer. The input electronics receive data from the various sensors, condition the incoming signals, and convert the signals to digital values for processing by the computer. The engine sensors are divided into three categories: control, limit, and in-flight data. Both the control and limit sensors are dual redundant. The in-flight or maintenance sensors are not redundant. The computer interface electronics control the input data to the computer, the output commands from the computer, and the overall flow of information within the controller. The interface electronics also provide the connection between the controller and the Orbiter's engine interface unit (EIU). This connection is used to transmit engine status and data to the vehicle over dual redundant channels. The digital computer is programmable to allow modification of engine control and monitoring algorithms. The computer has a memory capacity of 16,384 words (17 bit words, 16 bits for storage, 1 parity bit).

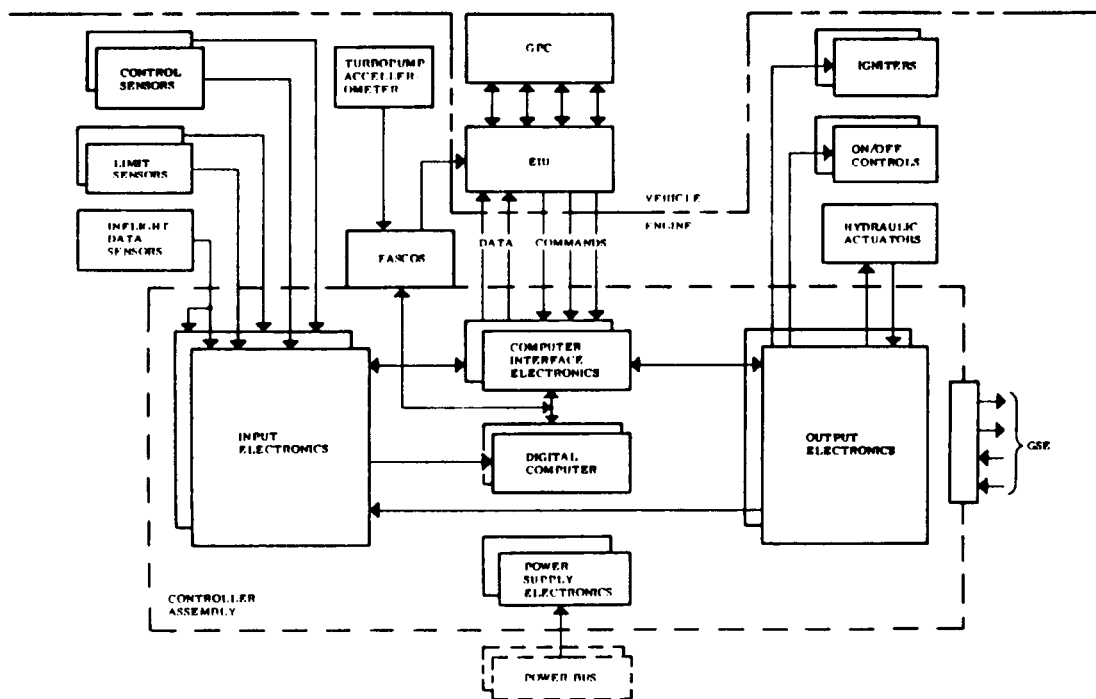

FIGURE 65. SSME CONTROLLER ORGANIZATION

The flight acceleration safety cutoff system (FASCOS) is another system related to condition monitoring which operates in combination with the engine controller. As shown in Figure 65, the FASCOS is a separate engine-mounted unit which is connected to both the SSME controller and the Orbiter EIU. The FASCOS receives vibration data from the turbopump accelerometers and shares this information with the controller. If vibration levels exceed a specified limit, FASCOS communicates this information to the EIU resulting in engine shut down. The FASCOS system has been undergoing extensive testing but has not been flown in a fully activated mode.

Orbiter Telemetry and Recording Systems

The Orbiter radiofrequency (rf) systems and data services are summarized in Reference 8. The principal elements connected with the SSME condition monitoring function are the FM signal processor, the data record/playback system, and the S-band FM transmitter. The FM signal processor accepts inputs from the SSMEs, the record/playback system, the Orbiter television system, and the payloads and selects the source for transmission by the S-band FM transmitter. The data record/playback system consists of two 14-track recorders with a capacity of up to 80 minutes each. One recorder is assigned as the operations unit while the other is designated as the payload unit. The S-band FM transmitter provides a single wide-band data channel from the Orbiter to the ground stations.

The S-band FM transmitter operates at a frequency of 2250.0 MHz and can provide the following downlinks (one at a time):

- Real-time engine data (3 channels @ 60 kbps each)
- 1 SSME data dump @ 60 kbps (one rate @ 16:1)
- Real-time television
- Real-time attached payload data
- 1 PCM telemetry dump @ 192 kbps
- 1 PCM telemetry dump @ 128 kbps.

The S-band FM data is routed from the Ground Space Tracking and Data Network (GSTDN) to the Space Shuttle Mission Control Center (MCC) at the NASA Johnson Space Center. Both real-time and playback engine data is communicated to the MCC at a rate of 1.544 Mbps.

Implications of SSME Monitoring Changes

Changes in the current on-board engine monitoring system could have significant impacts on some or all of the hardware and software elements described above. In addition to the purely technical considerations, it also will be necessary to evaluate any proposed changes from the prospective of the current Space Shuttle certification and operational procedures. This subsection discusses some of the implications associated with potential changes in the SSME diagnostic system.

Information on the condition of the SSME could be enhanced through the addition of sensors which would target specific types of failure information. The hardware impacts associated with this approach would include new access ports or mounting provisions, wiring harnesses, and connections to the controller input electronics. The resulting information could be processed and utilized inside the controller, recorded for later evaluation, or telemetered to the ground.

A factor to be considered in adding new on-board instrumentation is the increased weight associated with the sensors and wiring harnesses. While the weight of a few transducers and wires seems relatively minor, it must be remembered that the payload capacity of the Space Shuttle will be reduced by an equivalent amount. It would be relatively easy to design a condition monitoring system which would target many of the high-priority SSME failure modes. Unfortunately, this system could never be flown because of its weight. A delicate balance must be achieved between the weight of the diagnostic system and the information derived from it.

Another factor which affects both additional instrumentation and improved utilization of the current sensors is the on-board processing capacity of the controller. The condition monitoring capability of the current SSME controller (Block I) is limited by the internal memory. Insufficient capacity is available to process significant amounts of new

information. The Block II controller, which is currently undergoing developmental testing, has an increased amount of internal storage. Unfortunately, the design specifications dictate that the Block II controller must be functionally identical to the current unit. This requirement seems to preclude accessing the additional capacity of the new design to expand the condition monitoring system. The computational capacities of both the Block I and II controllers are insufficient for real-time diagnostic techniques such as expert systems or artificial intelligence (AI).

A potential means for improving the information yield from the current instrumentation involves processing and/or recording an increased bandwidth signal. Examining a higher bandwidth signal could provide additional data concerning the condition of the component(s) being monitored. Increasing the bandwidth of the sensor signals would have a potential impact on a number of systems including the controller, the controller to EIU data channels, the FM signal processor, the data recording/playback system, the S-band FM transmitter, and the GSTDN to MCC communications channels.

Most of the potential improvements to the on-board SSME condition monitoring system would involve hardware changes of one kind or another. Even if these modifications could be accomplished within all of the current component capabilities, a significant effort would be required to validate and certify the changes. The characteristics of the modified condition monitoring system and its interactions with the other engine components would have to be thoroughly understood and documented. In general, a condition monitoring system improves the availability of the item being monitored. The reliability of the overall system will usually be degraded due to the added diagnostic components which can also fail. Improvements in the on-board SSME condition monitoring system will require many years of careful and deliberate design, testing, and evaluation.

Changes in the on-board SSME condition monitoring system also would require corresponding changes in the operational criteria and procedures. To be effective, the data being collected must be analyzed, displayed, and utilized in the decision-making process. The revised operating guidelines should be defined and exercised during the developmental testing of the modified diagnostic system.

(This page intentionally blank)

SSME CONDITION MONITORING DEVELOPMENT

The task of postulating a development program and schedule for an improved SSME condition monitoring system is complicated by the changing nature of the engine hardware. Both NASA and Rocketdyne are constantly studying ways to improve the performance, reliability, and maintainability of the engine. These studies have produced new component designs as well as modifications to the current components. This section discusses some of the on-going SSME development programs. In addition, some specific condition monitoring needs, which are independent of the hardware, are outlined. The possible time frame and resources associated with improving the SSME monitoring system are also discussed. Finally, a document which outlines the requirements for future rocket engine condition monitoring systems is described.

Three major SSME hardware programs are currently in progress or anticipated. The first of these is the Phase II high-pressure turbopumps being developed by Rocketdyne. The design changes incorporated in these pumps are intended to extend the service life of the turbine blades and bearings. The Phase II turbopumps are undergoing certification testing at this time. A second program was awarded to Pratt and Whitney in 1986 to develop alternate turbomachinery designs, primarily the high-pressure turbopumps. The Pratt and Whitney turbopumps will be interchangeable with the current components. This program is still in the design and development stage. Ultimately, Pratt and Whitney will deliver prototype hardware to NASA for full-scale testing and evaluation on the oxygen/hydrogen technology test bed engine. A third program was recently announced by NASA. This program is similar to the alternate turbopump effort but encompasses the SSME powerhead, main combustion chamber, and nozzle. Test hardware also is likely to result from this program.

Each change to the current engine design alters the failure or degradation rates of the individual piece parts. This shifting of the failure patterns alters the monitoring priorities on which the diagnostic and control systems are based. However, three specific items appear to be leading condition monitoring candidates regardless of the exact SSME hardware configuration. These items are turbine blade erosion/cracking, bearing wear, and hydrogen leak detection. NASA, USAF, Rocketdyne, and

several other contractors currently are developing sensors to target these particular items. The turbine blades and bearings will no doubt be high priorities areas for any future high-performance rocket engine regardless of the propellant combination. The detection and isolation of hydrogen leaks also will be important for any engine which uses this particular fuel. Research and development activities related to these three problem areas should be expanded and accelerated.

Much fundamental research remains to be completed before a comprehensive SSME condition monitoring system can be developed. The planned introduction of the oxygen/hydrogen technology test bed engine during 1988 will provide a new and valuable asset in the continued development of sensors, signal processing, and diagnostic logic. The test bed engine will provide an intermediate step between proof-of-concept and the current engine testing conducted at the National Space Technology Laboratories (NSTL). Improvements in the SSME condition monitoring system will progress from the test bed engine to developmental testing at NSTL to actual implementation on flight engines.

An overall development schedule for an improved SSME condition monitoring system can only be discussed in general terms. It is likely that the next three to five years will be dominated by technology development and demonstration. The results of this research must then be factored into the actual design of any new diagnostic elements. This process could easily require another two to three years. Finally, the resulting system would be required to undergo two to three years of testing before used on Space Shuttle missions. The total time required to perform the necessary research, design the hardware or software, and certify it for flight could be from seven to ten years. While this may seem excessive, it is consistent with the general development cycle for major aerospace programs.

The resources required to develop and certify an improved condition monitoring system would depend on the selected configuration and the level of sophistication. The historic funding levels for this area would not be sufficient to accomplish any significant improvements in the time frame discussed above. However, there has been an expansion of the resources allocated to condition monitoring in the past year. These

increased levels must be continued if near-term (5-10 years) improvements are to be realized.

Over the past four years, the importance of condition monitoring systems has risen significantly. This fact is confirmed by the number of current studies concerned with condition monitoring. The increased emphasis is the result of both safety and reliability concerns and a desire to reduce the maintenance required between flights. This heightened awareness also has been accompanied by an expanded view of the interactions between the condition monitoring system and the engine/vehicle. The USAF Astronautics Laboratory currently is conducting a study to define a vehicle health management system (VHMS) architecture for an advanced launch system. This contract seeks to define an overall approach for developing an integrated condition monitoring system. The VHMS envisioned by the USAF would encompass the entire vehicle and not just the propulsion system. Because diagnostics are important for all vehicle subsystems, an integrated condition monitoring system will be a major factor in the design and development of advanced manned and unmanned launch vehicles.

During the course of this study, NASA MSFC requested inputs on condition monitoring requirements for the advanced Space Transportation Booster and Main Engines. The output of this effort was a short document titled "Diagnostic Monitoring System Requirements for the Space Transportation Booster and Main Engines (STBE and STME)". A copy of this document was forwarded to NASA MSFC in July 1986. A copy is contained in Appendix D of this report. The document is divided into six sections which include: general discussion, diagnostic system considerations during engine design, key diagnostic parameters, ground-test vs. flight diagnostics, in-flight vs. post-flight processing and analysis, and contractor implementation plan.

(This page intentionally blank).

MAIN ENGINE COST/OPERATIONS MODEL

A reported task dealt with studies of, and enhancements to the Main Engine Cost/Operations (MECO) model. This model is a combination of (1) a (deterministic) simulation of the processes of use and refurbishment of engines and components, (2) a detailed cost model, and (3) report formats which provide both cost and event data. It was used by NASA Headquarters and MSFC in a variety of hardware requirements/cost studies. Major activities on this task are summarized below.

Cost Spread Functions for Budget Planning Exercise

An adaptation of the MECO model was made to allow the conduct of budget planning exercises through the use of user-defined cost spread functions and delivery schedule. This modification provides cost summaries, by quarter, for both individual elements (e.g., HPOTP) and the overall SSME system. It does not require a simulation to be run to generate the model data.

Expanded Cost Displays

The cost displays which were originally rounded to the nearest \$1 million were revised and expanded to provide cost data rounded to the nearest \$10 thousand.

Revised Overhaul/Maintenance Procedures

Based on discussions with NASA Headquarters and MSFC personnel, major revisions were implemented in the engine and component overhaul logic to more accurately simulate then-current practice. This involved bypassing/revising the monitoring requirement for engine overhaul in s in case of certain failures.

Assessment of a Stochastic Model

A preliminary assessment of the requirements for, and benefits of, a stochastic version of the model was made and reviewed in informal discussions with the technical monitor.

Assessment of Graphics Requirements

A preliminary assessment was made of the potential for incorporating graphics into the model. This was reviewed informally with the technical monitor, who concluded that inclusion of graphics was not warranted at the time.

On-Going Support/Minor Modifications

From the initiation of the project until mid-1985, ongoing support in the form of advisory services and/or computer support was provided. In addition, a large number of relatively minor modifications were made to the program based on needs identified by the technological monitor.

Documentation

Flow charts of the overall model logic, are revised to be consistent with the modifications discussed above, were provided. These diagrams are intended to document the simulation sufficiently to provide a clear understanding of the underlying assumptions. The MECO logic diagrams are included as Appendix E of this report.

REFERENCES

1. Glover, R. C., Kelley, B. A. and Tischer, A. E., "Studies and Analyses of the Space Shuttle Main Engine, Technical Report Covering SSME Failure Data Review, Diagnostic Survey and SSME Diagnostic Evaluation", Battelle Memorial Institute, Columbus Division, BCD-SSME-TR-86-1, December 15, 1986, Contract No. NASw-3737.
2. Pau, L. F., *Failure Diagnosis and Performance Monitoring*, Marcel Dekkar, Incorporated, 1981.
3. "SSME Failure Mode and Effects Analysis and Critical Items List", Rockwell International Corporation, Rocketdyne Division, RSS-8553-9, November 15, 1984, Contract No. NAS8-27980.
4. Tischer, A. E., "Studies and Analyses of the Space Shuttle Main Engine, Technical Report on Failure Information Propagation Model Data Base and Software", Battelle Memorial Institute, Columbus Division, BCD-SSME-TR-87-2, December 15, 1987, Contract No. NASw-3737.
5. "Space Transportation System Training Data, SSME Orientation (Part A-Engine), Course No. ME-110(A)RIR", Rockwell International Corporation, Rocketdyne Division, October 1982, Contract No. NAS8-27980.
6. "Space Transportation System Technical Manual, SSME Description and Operation (Input Data), Space Shuttle Main Engine, Part Number RS007001", Rockwell International Corporation, Rocketdyne Division, E41000 RSS-8559-1-1-1, April 5, 1982, Contract No. NAS8-27980.
7. Glover, R. C., Rudy, S. W. and Tischer, A. E., "Studies and Analyses of the Space Shuttle Main Engine, Technical Report on High-Pressure Oxidizer Turbopump Failure Information Propagation Model", Battelle Memorial Institute, Columbus Division, BCD-SSME-TR-87-1, April 20, 1987, Contract No. NASw-3737.
8. Merriman, T. and Kannel, J., "High-Pressure Oxygen Turbopump Bearing Cage Stability Analysis", Battelle Memorial Institute, Columbus Division, March 8, 1984, Contract No. NAS8-34908, Task 113.

9. Tuten, J. and Kurre, M., "Diagnostic Monitoring of Axial Flow Fan Bearings", Third EPRI Conference on Incipient Failure Detection in Power Plants, March 9-12, 1987.
10. Anon., *Space Shuttle News Reference*, National Aeronautics and Space Administration.

APPENDIXES

APPENDIX A

FIPM DEVELOPMENT TOOLS

| <u>Tool</u> | <u>Page</u> |
|--|-------------|
| PRIMARY STEPS IN DEVELOPMENT OF FIPM | A-3 |
| FIPM ABBREVIATIONS | A-4 |
| ALLOWABLE FIPM VALUES | A-5 |
| REQUIRED DATA FIELDS | A-7 |
| DATA FIELDS WHICH CANNOT BE MODIFIED | A-9 |
| FORM FOR GENERATING FAILURE INFORMATION PROPAGATION DATA | A-10 |
| RULES USED FOR SSME FIPMs | A-11 |
| GENERIC FAILURE MODE DESCRIPTIONS | A-15 |

(This page intentionally blank)

PRIMARY STEPS IN DEVELOPMENT OF FIPM

1) FIPM Drawing

- a) Assign unique designator to system
- b) Identify modules which comprise system
- c) Assign unique number to each module
- d) Generate a descriptive name for each module
- e) List the potential failure modes for each module
- e) Identify physical connections between the modules

2) FIPM Data Base

- a) Generate and enter data for domain REFERENCES
- b) Generate and enter data for domain SYSTEMS
- c) Generate and enter data for domain MODULES
- d) Generate and enter data for domain FAILUREMODES
- e) Generate and enter data for domain CONNECTIONS
- f) Generate and enter data for domain PROPAGATIONS_@### *

* @### represents the four-character code for the current system.

FIPM ABBREVIATIONS

Failure Modes:

BN - Binding
CN - Connection
CR - Corrosion
CV - Cavitation
DF - Deformation
ER - Erosion
FA - Fracture
FI - Friction
IM - Impact
IP - Internal pressure
LK - Leak
MP - Material properties
OX - Oxidation
PD - Pressure differential
PT - Pitting
RB - Rubbing
RE - Rolling element
SD - Surface deposition
SL - Slippage
ST - Static loading
TF - Thermal fatigue
TL - Tolerance
VF - Vibration Fatigue
WR - Wear

Connections:

CP - Common piece
GA - Gaseous
H2 - Hydrogen
HE - Helium
HG - Hot gas
LQ - Liquid
ME - Mechanical
O2 - Oxygen
RE - Rolling element
TP - Two phase

ALLOWABLE FIPM VALUES

Reference Sources:

AEROJET
BATTELLE
MARTIN MARIETTA
NASA HDQ
NASA MSFC
PRATT & WHITNEY
ROCKETDYNE

Failure Modes:

CR OX - CORROSION: OXIDATION
DF IM - DEFORMATION: IMPACT
DF IP - DEFORMATION: INTERNAL PRESSURE
DF ST - DEFORMATION: STATIC LOADING
DF SD - DEFORMATION: SURFACE DEPOSITION
FA IM - FRACTURE: IMPACT
FA IP - FRACTURE: INTERNAL PRESSURE
FA ST - FRACTURE: STATIC LOADING
FA TF - FRACTURE: THERMAL FATIGUE
FA VF - FRACTURE: VIBRATION FATIGUE
FI BN - FRICTION: BINDING
FI SL - FRICTION: SLIPPAGE
LK CN - LEAK: CONNECTION
LK ER - LEAK: EROSION
LK FA - LEAK: FRACTURE
LK PD - LEAK: PRESSURE DIFFERENTIAL
LK TL - LEAK: TOLERANCE
MP SD - MATERIAL PROPERTIES: SURFACE DEPOSITION
WR CV - WEAR: CAVITATION
WR ER - WEAR: EROSION
WR PT - WEAR: PITTING
WR RE - WEAR: ROLLING ELEMENTS
WR RB - WEAR: RUBBING

ALLOWABLE FIPM VALUES (CONTINUED)

Connections:

GA H2 - GASEOUS: HYDROGEN
GA HE - GASEOUS: HELIUM
GA HG - GASEOUS: HOT GAS
GA O2 - GASEOUS: OXYGEN
LQ H2 - LIQUID: HYDROGEN
LQ HE - LIQUID: HELIUM
LQ O2 - LIQUID: OXYGEN
ME -- - MECHANICAL
ME CP - MECHANICAL: COMMON PIECE
ME RE - MECHANICAL: ROLLING ELEMENT
TP H2 - TWO PHASE: HYDROGEN
TP HE - TWO PHASE: HELIUM
TP O2 - TWO PHASE: OXYGEN

Signals:

ACOUSTIC
ELECTRICAL
FLOW
PRESSURE
RPM
THERMAL
TORQUE
VIBRATION
WORN PARTICLES

Parameters:

AMPLITUDE
FREQUENCY
PHASE

REQUIRED DATA FIELDS

Domain REFERENCES:

| | |
|-----------------|---------------------------------|
| DOCUMENT_TITLE | [REPORT OR DOCUMENT TITLE:] * |
| DOCUMENT_SOURCE | [ORIGINATING ORGANIZATION:] |
| DOCUMENT_DATE | [DOCUMENT DATE (DD-MMM-YYYY):] |

Domain SYSTEMS:

| | |
|-------------|--|
| SYSTEM | [SYSTEM:] |
| SYSTEM_NAME | [SYSTEM NAME:] |
| ITEM1 | [CONSTITUENT ROCKETDYNE FMEA ITEMS: 1)] |
| REFERENCE1 | [REFERENCE DOCUMENTS: 1)] |

Domain MODULES:

| | |
|--------------------|-----------------|
| SYSTEM | [SYSTEM:] |
| MODULE | [MODULE:] |
| SYSTEM_MODULE_NAME | [MODULE NAME:] |

Domain FAILUREMODES:

| | |
|--------------------------|----------------------------------|
| SOURCE_SYSTEM_MODULE | [SOURCE SYSTEM AND MODULE:] |
| FAILURE_MODE_SUBMODE | [FAILURE MODE AND SUBMODE:] |
| ACCOMPLICE_SYSTEM_MODULE | [ACCOMPLICE SYSTEM AND MODULE:] |

Domain CONNECTIONS:

| | |
|--------------------------|---------------------------------------|
| SYSTEM_MODULE_A | [SYSTEM AND MODULE A:] |
| CONNECTION | [CONNECTION (TYPE AND QUALIFIER):] |
| UNANTICIPATED_CONNECTION | [UNANTICIPATED CONNECTION (T OR F):] |
| SYSTEM_MODULE_B | [SYSTEM AND MODULE B:] |

* The item in brackets is the data prompt as it appears on the input form.

REQUIRED DATA FIELDS (CONTINUED)

Domain PROPAGATIONS_@### **:

| | |
|-------------------|-----------------------|
| CODE NUMBER | [CODE NUMBER:] |
| SIGNAL_QUALITY | [SIGNAL QUALITY:] |
| FMCODE | [FMCODE:] |
| SIGNAL_TYPE | [SIGNAL TYPE:] |
| DIMENSIONS | [DIMENSIONS:] |
| MAX_FREQ_OR_TIME | [MAX. FREQ./TIME:] |
| MIN_FREQ_OR_TIME | [MIN. FREQ./TIME:] |
| PARAMETER | [PARAMETER:] |
| SYMPTOM_DURATION | [SYMPTOM DURATION:] |
| PERIOD_OF_ONSET | [PERIOD OF ONSET:] |
| INDICATES_FAILURE | [INDICATES FAILURE:] |

** @### represents the four-character code for the current system.

DATA FIELDS WHICH CANNOT BE MODIFIED

Domain REFERENCES:

DOCUMENT_TITLE [REPORT OR DOCUMENT TITLE:] *
 DOCUMENT_SOURCE [ORIGINATING ORGANIZATION:]
 DOCUMENT_DATE [DOCUMENT DATE (DD-MMM-YYYY):]

Domain SYSTEMS:

SYSTEM [SYSTEM:]

Domain MODULES:

SYSTEM [SYSTEM:]
 MODULE [MODULE:]

Domain FAILUREMODES:

SOURCE_SYSTEM_MODULE [SOURCE SYSTEM AND MODULE:]
 FAILURE_MODE_SUBMODE [FAILURE MODE AND SUBMODE:]
 ACCOMPLICE_SYSTEM_MODULE [ACCOMPLICE SYSTEM AND MODULE:]

Domain CONNECTIONS:

All Fields

Domain PROPAGATIONS_@### **:

CODE NUMBER [CODE NUMBER:]
 FMCODE [FMCODE:]
 SIGNAL TYPE [SIGNAL TYPE:]
 PARAMETER [PARAMETER:]

* The item in brackets is the data prompt as it appears on the input form.

** @### represents the four-character code for the current system.

FORM FOR GENERATING FAILURE INFORMATION PROPAGATION DATA

FAILURE INFORMATION PROPAGATION RECORD

DATE: ____ / ____ / ____ AUTHOR: _____

[] Data Entered [] Data Verified

=====

CODE_NUMBER: _____ _____ _____ _____ _____ _____ _____
CONNECTIVITY SYSTEM MODULE NO. COUPLING COUPLING UNANTICIPATED SYSTEM MODULE NO.
CODE ***** MODULE A ***** QUALIFIER (T OR F) ***** MODULE B *****

SIGNAL_QUALITY: 0 1 2 3 4 5
 VERY WEAK MODERATE STRONG

FMCODE: _____ _____ _____ _____ _____ _____ _____
FAILURE MODE SYSTEM MODULE NO. FAILURE FAILURE SYSTEM MODULE NO.
CODE ***** SOURCE MODULE ***** MODE SUBMODE *** ACCOMPLICE MODULE ***

SIGNAL_TYPE: FLOW TORQUE RPM
 PRESSURE VIBRATION ACOUSTIC
 THERMAL ELECTRICAL WORN PARTICLES

DIMENSIONS: 1 2 3

MAX_FREQ_OR_TIME: 1. E _____

MIN_FREQ_OR_TIME: 1. E _____

PARAMETER: FREQUENCY AMPLITUDE PHASE

SYMPTOM_DURATION: 1. E _____

PERIOD_OF_ONSET: 1. E _____

INDICATES_FAILURE: T or F

COMMENT1: _____
(MAX. 80 CHAR.) _____

COMMENT2: _____
(MAX. 80 CHAR.) _____

COMMENT3: _____
(MAX. 80 CHAR.) _____

=====

RULES USED FOR SSME FIPMs

MODULE SELECTION

There are no fixed rules for specifying the level of the modules selected for the FIPM. In some cases, individual piece parts from a parts list may be used. In other cases, an assembly of parts which has a single function and straight forward failure modes may be selected. In all cases, the decision will be based on the function of the part or parts. Each function will be represented by a separate module.

MODULE NUMBERING SCHEME

All modules of the FIPM shall be uniquely identified by the combination of a four-character system code and a four-digit number.

Example: B400 0010

COMMON-PIECE CONNECTIONS

When a single part serves multiple functions, each function will be represented as a distinct module. These modules will be connected by ME CP (MECHANICAL: COMMON PIECE) connections. The modules will be named as follows:

PART NAME -- FUNCTION

Example: SHAFT ASSEMBLY
SHAFT ASSEMBLY -- LUBRICATION PASSAGE

FASTENERS

Fasteners are represented in the FIPM as a single module with a ME -- (MECHANICAL) connection to each of the parts being joined. No direct connection will be shown between the parts being joined.

Fasteners which join modules from two adjacent systems (e.g., B400 and B600) will be associated with the upstream system.

Example: The fasteners which attach the LPOTP Pump Discharge Duct (module of system B800) to the Main Pump Housing -- Inlet Manifold (module of system B400) will be a module of system B800.

RULES USED FOR SSME FIPMs (CONTINUED)

FASTENERS (CONTINUED)

For fasteners which join rotating components or are in close proximity to rotating components, increased vibration levels, etc. will be seen prior to fastener failure.

Example: Seal fasteners

For fasteners not joining rotating components or not in close proximity to rotating components, fastener failure must occur before higher vibration levels, etc. will be observed.

Example: Duct fasteners

WEAR: RUBBING

The failure mode WR RB is the result of an interaction between two modules. This failure mode will be associated with the moving module. The code used to describe this failure mode will include the name of the stationary (accomplice) module.

LEAK: CONNECTION

The failure mode LK CN represents a fluid leak which occurs at the connection between two modules. This failure mode will be associated with the module on the upstream side of the connection. The code used to describe this failure mode will indicate the module (accomplice) which forms the other half of the connection.

Example: A leak at the connection between the LPOTP discharge duct (B800) and the main pump housing -- inlet manifold (B400) will be identified as a failure mode of the LPOTP pump discharge duct since it is the upstream module.

UNANTICIPATED CONNECTIONS

An unanticipated connection will always be indicated for components which include the following failure modes:

LK CN - LEAK: CONNECTION
 LK ER - LEAK: EROSION
 LK FA - LEAK: FRACTURE
 LK PD - LEAK: PRESSURE DIFFERENTIAL
 LK TL - LEAK: TOLERANCE
 WR RB - WEAR: RUBBING

RULES USED FOR SSME FIPMs (CONTINUED)

DUCTS

A duct will be defined as being a module of the upstream system to which it is attached.

Examples: LPFTP pump discharge duct is a module in the low-pressure fuel turbopump FIPM. High-pressure fuel duct is a module in the high-pressure fuel turbopump FIPM.

VALVES

A valve will be defined as being a module of the downstream system into which the flow is being controlled or modulated by the valve.

Examples: The main oxidizer valve (MOV) is a module in the main injector FIPM. The anti-flood valve (AFV) is a module in the heat exchanger FIPM.

EXTERNAL CONNECTIONS

Any connections which exist between FIPM systems will be represented in the model of both systems.

Example: The connection between the LPOTP discharge duct (system B800) and the main pump housing -- inlet manifold (system B400) will be represented in the FIPMs for both systems.

The external connections will be appropriately identified on the FIPM drawing. Failure modes will not be identified for the module from the adjacent system.

When generating failure information propagations, the signals will be propagated to the external connections. However, the information flow will not proceed through the adjacent system.

SEALS

For seals between a moving and a stationary part, the seal function will be associated with the stationary part.

RULES USED FOR SSME FIPMS (CONTINUED)

ALLOWABLE VALUES

The allowable values used for the SSME FIPMSs should be viewed as a dynamic set of parameters which can and should evolve as new models are developed. It is quite likely that models of additional engine components would require new connections and new failure modes.

Example: LQ N2 - LIQUID: NITROGEN

GENERIC FAILURE MODE DESCRIPTIONS

- CR OX - LOSS OF SURFACE MATERIAL THROUGH THE CHEMICAL PROCESS OF OXIDATION
- DF IM - ALTERATION OF PHYSICAL DIMENSIONS DUE TO IMPACT OF DEBRIS FROM UPSTREAM FAILURES OR CONTAMINATION
- DF IP - ALTERATION OF PHYSICAL DIMENSIONS DUE TO EXCESSIVE PRESSURE LOADING
- DF ST - ALTERATION OF PHYSICAL DIMENSIONS DUE TO EXCESSIVE STATIC LOADING
- DF SD - ALTERATION OF PHYSICAL DIMENSIONS DUE TO ACCUMULATION OF PARTICULATE MATTER
- FA IM - CRACKING DUE TO IMPACT OF DEBRIS FROM UPSTREAM FAILURES OR CONTAMINATION
- FA IP - CRACKING DUE TO EXCESSIVE PRESSURE LOADING
- FA ST - CRACKING DUE TO EXCESSIVE STATIC LOADING
- FA TF - CRACKING DUE TO EXCESSIVE CYCLICAL AND TRANSIENT THERMAL LOADING
- FA VF - CRACKING DUE TO EXCESSIVE CYCLICAL AND TRANSIENT MECHANICAL LOADING
- FI BN - TIGHTENING DUE TO UNEXPECTED LOADING OR DIMENSIONAL GROWTH DURING OPERATION
- FI SL - LOOSENING DUE TO EXCESSIVE CYCLICAL OR TRANSIENT LOADING (MECHANICAL OR THERMAL)
- LK CN - _____ LEAKAGE DUE TO INSUFFICIENT MECHANICAL COUPLING WITH ADJACENT COMPONENT (_____)
- LK ER - _____ LEAKAGE DUE TO COMPONENT BURN THROUGH CAUSED BY EXCESSIVE EROSION
- LK FA - _____ LEAKAGE DUE TO CRACK PROPAGATION FROM FRACTURE FAILURE
- LK PD - _____ LEAKAGE DUE TO LOSS OF _____ PRESSURANT
- LK TL - _____ LEAKAGE DUE TO DIMENSIONAL CHANGES CAUSED BY WEAR
- MP SD - ALTERATION OF THE PHYSICAL PROPERTIES OF THE MATERIAL DUE TO ACCUMULATION OF PARTICULATE MATTER

GENERIC FAILURE MODE DESCRIPTIONS (CONTINUED)

WR CV - ABRASION DUE TO EXCESSIVE PRESSURE OSCILLATIONS CAUSED BY CAVITATION

WR ER - ABRASION DUE TO HOT GASES AND PARTICULATE MATTER IN FLOW

WR PT - LOSS OF SURFACE MATERIAL DUE TO EXCESSIVE CYCLICAL AND TRANSIENT MECHANICAL LOADING

WR RE - ABRASION DUE TO CONTACT FORCES BETWEEN ROLLING ELEMENTS

WR RB - ABRASION DUE TO MECHANICAL CONTACT BETWEEN COMPONENTS WITH RELATIVE MOTION (_____ WITH _____)

APPENDIX B

SSME FIPM DRAWINGS

(SEE SEPARATE VOLUME OF THIS REPORT)

APPENDIX C

EXCERPT FROM

"HIGH-PRESSURE OXYGEN TURBOPUMP BEARING CAGE STABILITY ANALYSIS"

REPORT TO NASA MSFC BY

BATTELLE COLUMBUS DIVISION

SUMMARY AND CONCLUSIONS

Combinations of operating conditions and cage dimensions were identified that can cause the cage of the HPOTP turbine-end bearings to be unstable. Furthermore, the high accelerations associated with the instabilities can be expected to cause forces sufficient to fail the cage (depending upon the actual strength of the cage under operating conditions). The forces on the cage developed under normal (stable) operating conditions were found to be tolerable. Therefore, maintaining stable operation of the cage appears to be important in successful operation of the HPOTP bearings.

Cage stability was found to be particularly sensitive to the cage-race clearance, cage balance, and the lubricant film thickness between the balls and races (as it affects the ball-race traction). Cage-race diametral clearances larger than 0.25 mm (0.01 in.) promote cage instabilities. In contrast, cage stability was found to be insensitive to ball-pocket clearance. Since small cage unbalances were predicted to cause instabilities, the cages should be carefully balanced to minimize instability problems. Depletion of lubricant film thicknesses between the balls and races cause cage instability problems by increasing the ball-race traction, which underlines the importance of maintaining adequate lubrication for successful long-term bearing life.

As a result of the study, several sensitive parameters affecting bearing dynamics were clearly identified. Therefore, modifications to the bearings to minimize the likelihood of cage instability should enhance cage stability and associated bearing reliability.

RECOMMENDATIONS

Based on the analyses, the following specific recommendations are made to minimize cage instability and its associated effects on bearing degradation.

1. Maintain the diametral cage-race clearance at no more than 0.25 mm (0.010 in.). Current specifications on the drawing of bearing 007955 for cage-race clearance are 0.38 mm (0.015 in.) to 0.74 mm (0.029 in.). This tolerance should be changed to reflect the 0.25 mm (0.010 in.) maximum allowable recommendation.
2. The clearance between the balls and pockets in the cage should be no less than 0.54 mm (0.025 in.). The ball-pocket clearance does not affect cage stability, but adequate clearance is needed to avoid cage stresses from ball-speed variations caused by combinations of axial and radial loads. It is recommended that the current drawing specification of 0.64 mm (0.025 in.) to 0.89 mm (0.035 in.) for ball-pocket clearance in the circumferential direction be modified to be 2.3 mm (0.090 in.) to 2.5 mm (0.100 in.) to reflect this requirement.
3. Dynamically balance the cages to minimize the effect of cage unbalance on stability.
4. Continue efforts to understand and promote adequate lubrication of the ball-race interface. This analysis has shown the importance of lubrication to cage stability, and previous Tasks have underscored the importance of lubrication to ball and race longevity. Long-term life of the HPOTP bearings depends critically on developing and maintaining lubricant films to separate the balls and races.
5. Perform a more detailed analysis of the cage stresses developed in operation. While the BASDAP analyses provide data on the ball-cage

forces, the actual stresses developed result from a combination of these forces with the cage geometry and constraints by the outer (guiding) race. The current study permitted only an approximate consideration of these stresses.

6. Schedule a review meeting to be attended by NASA, Rocketdyne, and Battelle personnel to review the implications of the findings in this Task and determine what practical steps can be taken to minimize potential cage instability problems.

(This page intentionally blank)

APPENDIX D

STBE AND STME DIAGNOSTIC REQUIREMENTS DOCUMENT

**DIAGNOSTIC MONITORING SYSTEM REQUIREMENTS
FOR THE
SPACE TRANSPORTATION BOOSTER AND MAIN ENGINES (STBE and STME)**

General Discussion

A diagnostic monitoring system shall be included as a key item in the design of both the Space Transportation Booster Engine (STBE) and the Space Transportation Main Engine (STME). The purpose of this system will be to acquire data relative to the performance and overall condition of the engine and its associated components. The data obtained from the diagnostic system will be used to characterize nominal engine operating conditions, quantify limits on key engine parameters, identify degradations in engine performance, warn of impending failures, and provide input on maintenance requirements. The information collected by the system may be processed and used on a real-time basis during engine operation, recorded for use in post-test or post-flight analyses, or utilized in a mode combining both real-time and post-operation processing. Anticipated benefits from the diagnostic system include improved identification and warning of anomalous engine conditions, extended intervals between engine inspections, and increased data on which to base maintenance decisions. To satisfy all of the objectives outlined above, it will be necessary to consider the diagnostic system as an integral part of the engine design and development program.

The diagnostic monitoring system for the STBE and STME will include all elements necessary to fulfill the objectives discussed previously including appropriate sensors or procedures, signal conditioning and formatting devices, means for transmission and recording of collected data, on-board or ground-based processors, respective decision making criteria, and associated computational algorithms. It is recognized that the requirements for safety versus maintenance diagnostics vary widely in terms of speed, reliability, number of parameters, etc. The monitoring system must include provisions to accommodate this situation while fully

exploiting the joint data elements needed for both roles. The diagnostic system design will make maximum use of automated techniques and procedures where feasible to improve the overall quality and consistency of the engine data. However, the overall diagnostic system concept should also consider other appropriate techniques for determining engine condition and maintenance requirements such as human or human-assisted inspections, tests, or analyses. The respective roles of in-flight and ground-based processing and analysis must also be carefully evaluated in the design of any prospective engine monitoring system. The principal criteria on which diagnostic system trades will be based is flight safety but cost factors will also play a role in determining the final configuration and mode of operation.

The diagnostic monitoring system, in addition to providing specific data relative to the engine and its components, shall be considered in the broader context of the overall maintenance and maintainability program for both the STBE and STME. The prior experience with reusable liquid rocket engines has shown that maintenance and maintainability are major factors in the overall operational costs attributable to the engine. Integrated planning in this important area may yield significant cost improvements for new engine designs. The diagnostic system interactions with and contributions to the maintenance/maintainability program must be evaluated during the formulation of the STBE and STME designs.

Diagnostic System Considerations During Engine Design

The diagnostic monitoring system will introduce four major considerations to the overall design of the STBE and STME. The first is the selection of the number and type of sensors required to implement the desired diagnostic strategy. This decision is strongly related to the overall level of confidence required in the diagnostic measurements and the issue of sensor reliability in the operating environment associated with large, high-performance, liquid rocket engines. The second is the incorporation of adequate provisions for sensor or inspection access to the required measurement locations. This access may or may not be intrusive to

the component being monitored depending on the particular sensor selected for the application. The third is the evaluation of the environmental conditions imposed on the sensors during engine operation. This issue must be addressed so that adequate protection or isolation can be provided where necessary. The final consideration is the computational capacity required in the engine controller to implement the selected diagnostic and control approach. In view of the items mentioned above, the diagnostic monitoring system must be considered from the very beginning of the engine design and development cycle.

Key Diagnostic Parameters

The parameters of particular importance in assessing engine condition and maintenance requirements are generally associated with the turbomachinery, combustion devices, propellant/coolant flows, and actuator/valve positions. Specific parameters of interest include but are not limited to turbopump shaft speeds, turbopump torque levels, turbine outlet values, turbopump bearing condition, turbine blade stresses, main combustion chamber conditions, preburner chamber values, total oxidizer and fuel flow rates, flow rates associated with coolant or purge fluids, position of the main oxidizer and fuel valves, and information relative to the position or proper functioning of other critical valves and actuators. Another area of increasing interest pertains to new or novel approaches to detect and locate leaks in the various engine components. The fundamental physical measurements required to obtain the information described above include temperature, pressure, strain, acceleration, acoustic, and optical. The first four measurement types represent conventional sensors widely used in rocket engines and other similar applications. Acoustic and optical sensors are newer approaches but should be considered in view of their overall potential. The design of the diagnostic monitoring system also should carefully consider the sampling rate and signal format associated with the measurements. Current systems tend to use RMS (Root Mean Square) values sampled at discrete intervals on the order of 20 milliseconds. This type of monitoring eliminates the spectral content associated with the raw

signal. Careful consideration should be given to systems which can process the entire sensor output spectrum for at least selected measurement parameters.

Ground-Test Versus Flight Diagnostics

The diagnostic system shall be required to collect appropriate engine data in both the ground-test and flight environments. The requirements for the engine monitoring system will differ slightly in these two cases even though the basic goals of safe and efficient operations remain the same. The minimum diagnostic system will consist of those elements necessary to fulfill the flight monitoring and control functions as initially defined by the contractor. However, it is recognized that information obtained during developmental, test-stand firings will form the foundation for the overall understanding of the engine and its operating characteristics. This fundamental role may impose additional requirements for ground-test diagnostic data above and beyond those needed during actual flight operations. The proposed monitoring system must consider the implications of this situation and provide the flexibility to accommodate additional measurements without major modifications to the engine hardware. Provisions should at least be made in the basic design for any access ports or mounting surfaces which may be required to support the various sensors or test procedures used during engine characterization. Requirements for additional test site facilities or equipment to support the ground-test diagnostic measurements should be specified also.

In-Flight Versus Post-Flight Processing and Analysis

The diagnostic system design shall address the relative need for real-time processing and analysis of engine data during flight. Information needed to assess engine condition, operating trends, and control responses must be available on a real time or near real time basis to satisfy safety considerations. Additional data pertaining to required maintenance actions which do not affect the current mission may be recorded for later review and

analysis. The monitoring system will provide the capability to handle both types of data and direct the respective information streams to the appropriate storage or processing devices. The information required for real-time monitoring and control of the engine may be processed and analyzed in several ways. The actual option used will depend on the selected engine control scheme and the relative role of the diagnostic system within that scheme. In all cases, the information from the various sensors comprising the on-board monitoring system will be collected, preprocessed, and formatted by the engine controller. Three potential sites exist at which the diagnostic data may undergo additional processing/analysis. The information may be transmitted to the ground for computer or human analysis, passed to the vehicle flight computers for processing and subsequent action, or analyzed directly by the engine controller in a self-contained mode of operation. The diagnostic system may use any, all, or some combination of these approaches to satisfy the in-flight monitoring requirements.

Contractor Implementation Plan

The prospective STBE and STME contractors shall include the diagnostic monitoring system as a required element in the preliminary engine design phase. The contractor must describe the proposed diagnostic system in sufficient detail to demonstrate that the concept meets all of the overall system objectives as outlined herein. The analyses and trades conducted during formulation of the proposed concept will also be discussed to demonstrate the rationale associated with selection of the major system elements or features. All interfaces between the diagnostic system and the engine or vehicle will be specified. The diagnostic system requirements associated with other engine or vehicle systems such as power, data storage, telemetry, etc. will be identified to the extent possible. The role of the diagnostic monitoring system in the maintenance/maintainability program for the respective engine will be described and any major contributions to improved maintenance/maintainability will be outlined. The contractor shall specifically discuss the overall approach to ground-test and flight diagnostics and define any unique test site requirements associated with the

selected engine monitoring system. The contractor also will discuss the preferred approach for the processing and analysis of in-flight engine data. The computational requirements imposed by the selected concept will be outlined with specific reference to engine, vehicle, and ground-based processors. The post-flight maintenance evaluation will be described to complete the definition of the overall diagnostic system and to allow assessment of the interactions between in-flight and post-flight monitoring requirements.

APPENDIX E

MAIN ENGINE COST/OPERATIONS MODEL
LOGIC DIAGRAMS

SSME
OPS PROCESSING:
PRE-MISSION

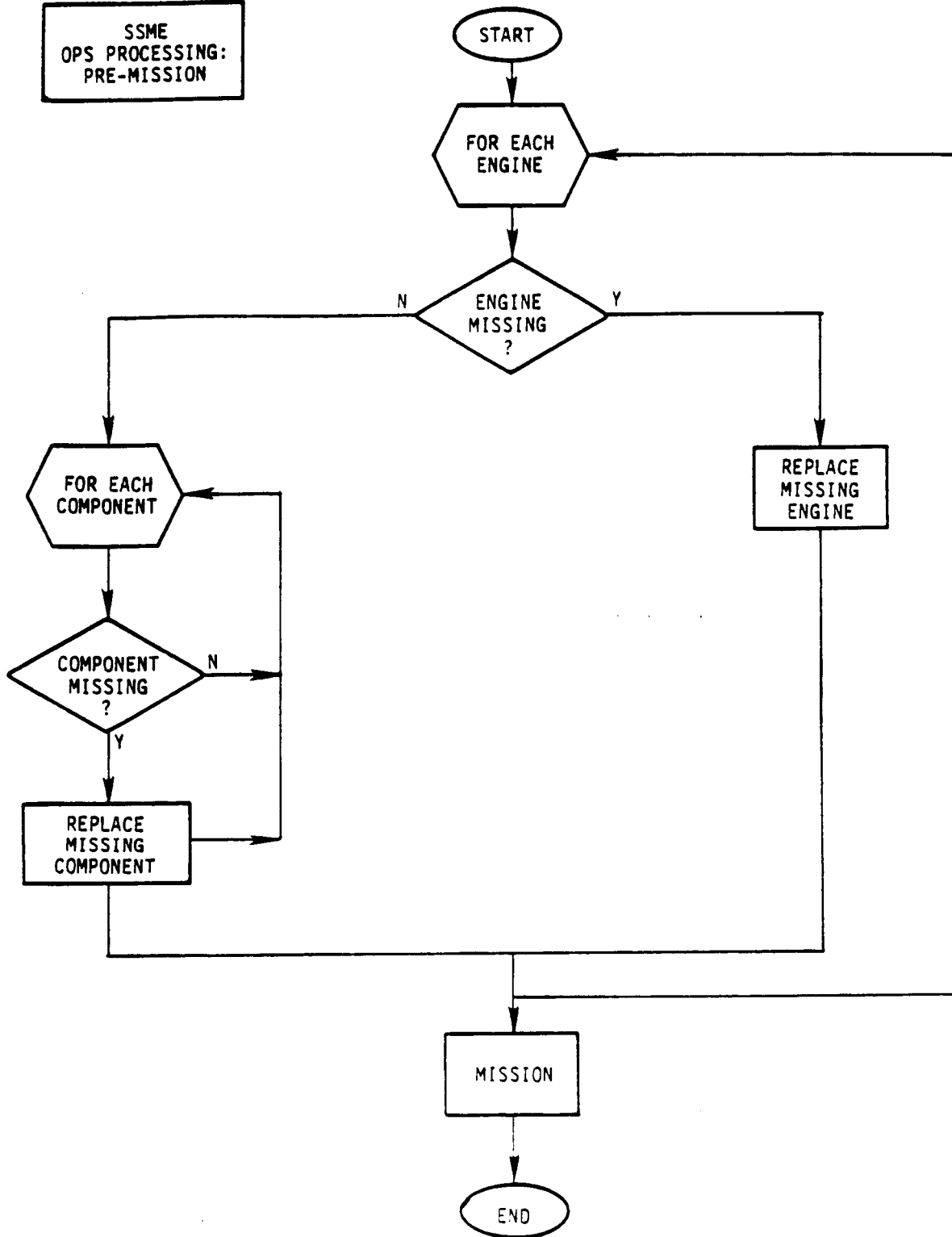

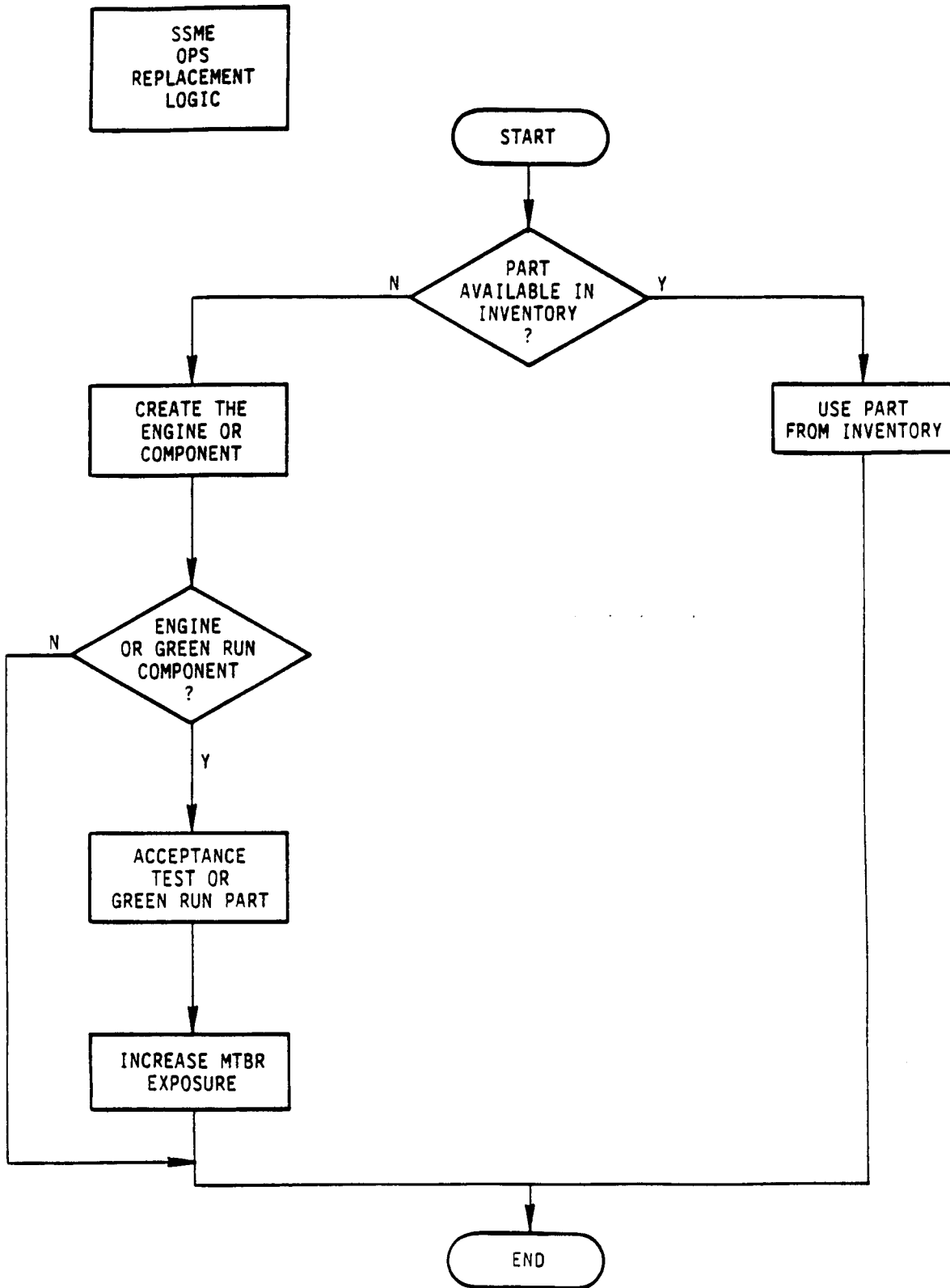

SSME
OPS PROCESSING:
POST-MISSION

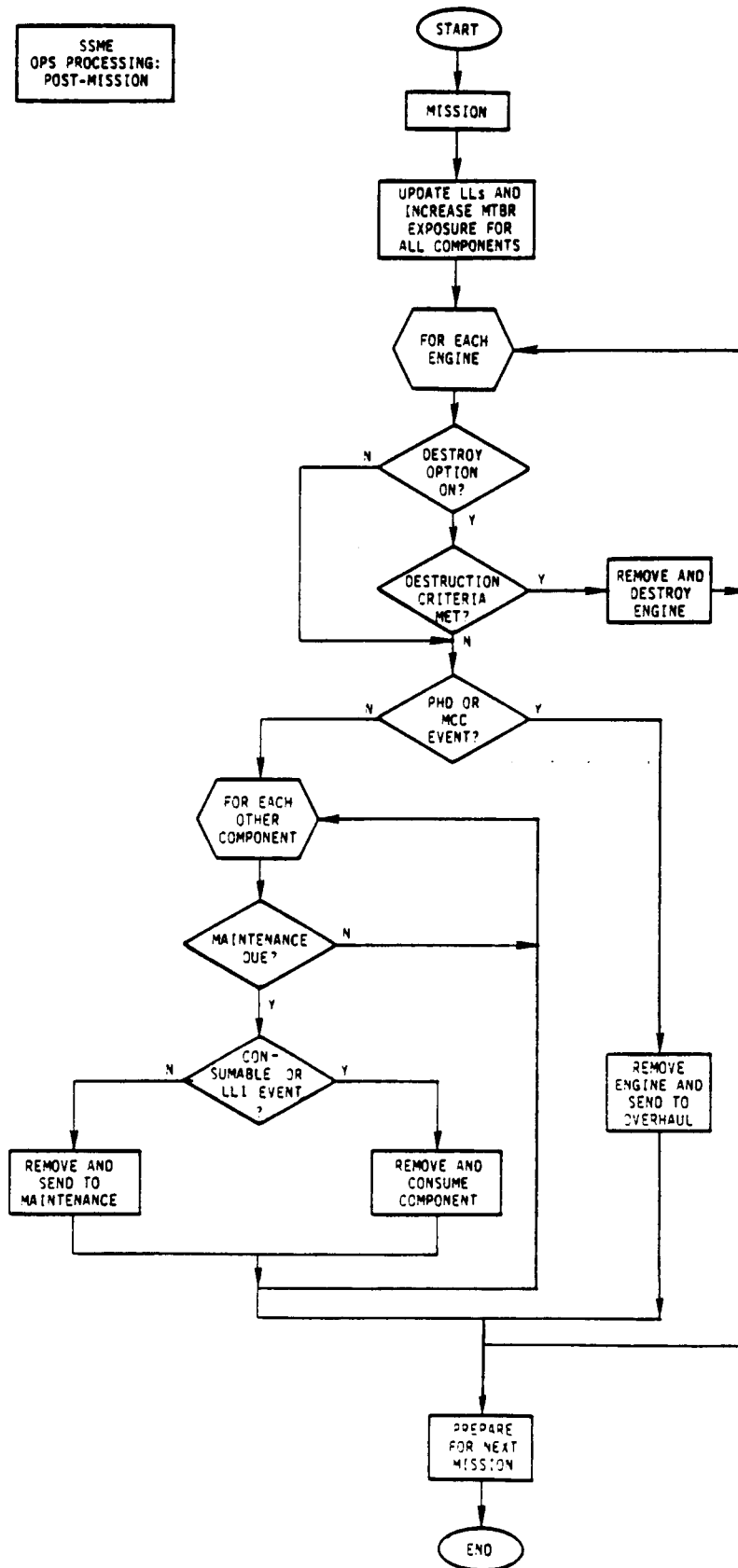

SSME
ENGINE OVERHAUL

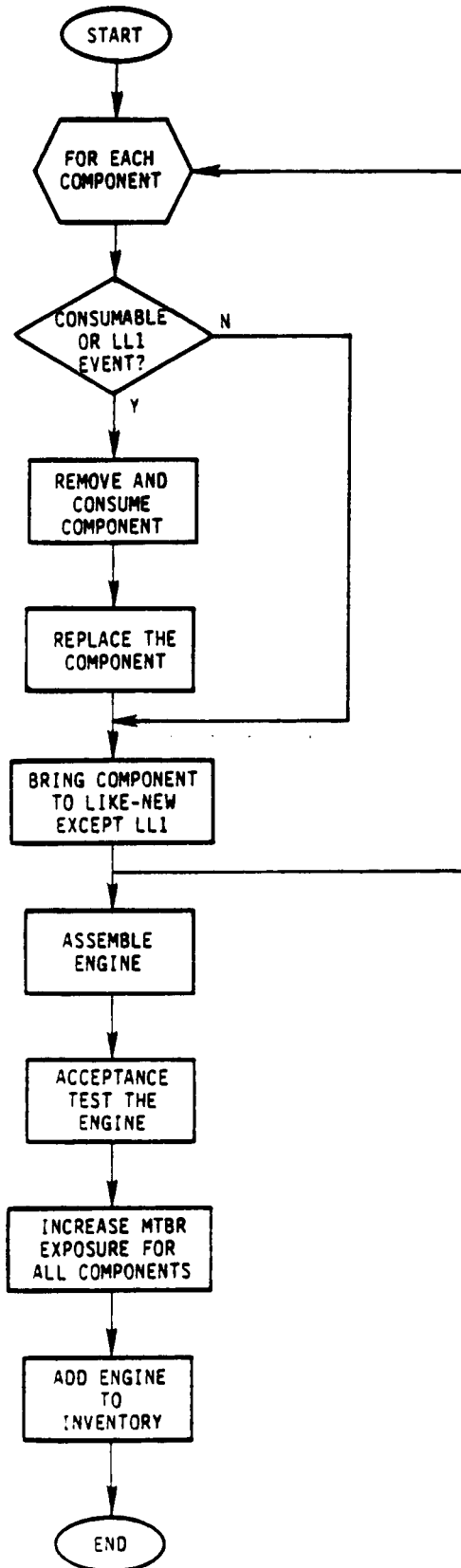

SSME
COMPONENT
MAINTENANCE

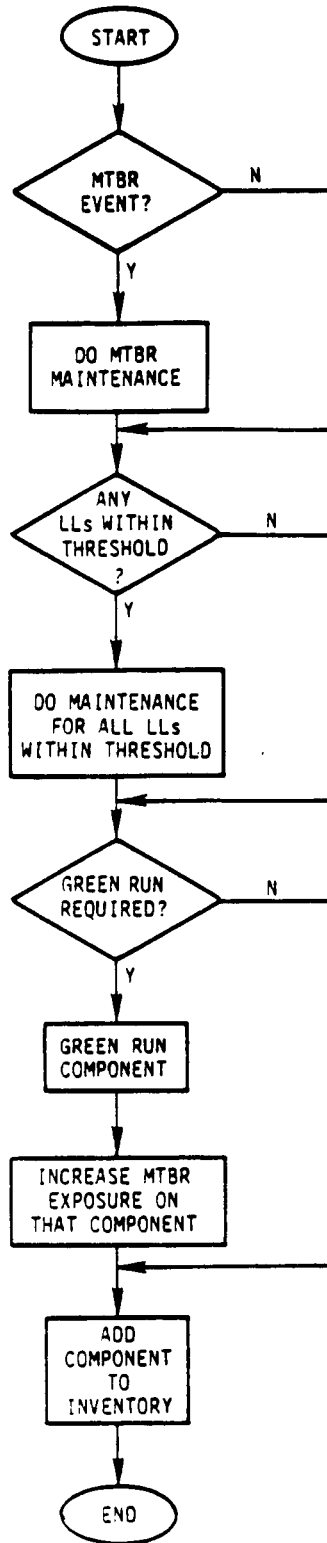

SSME
F/C PROCESSING:
CYCLES

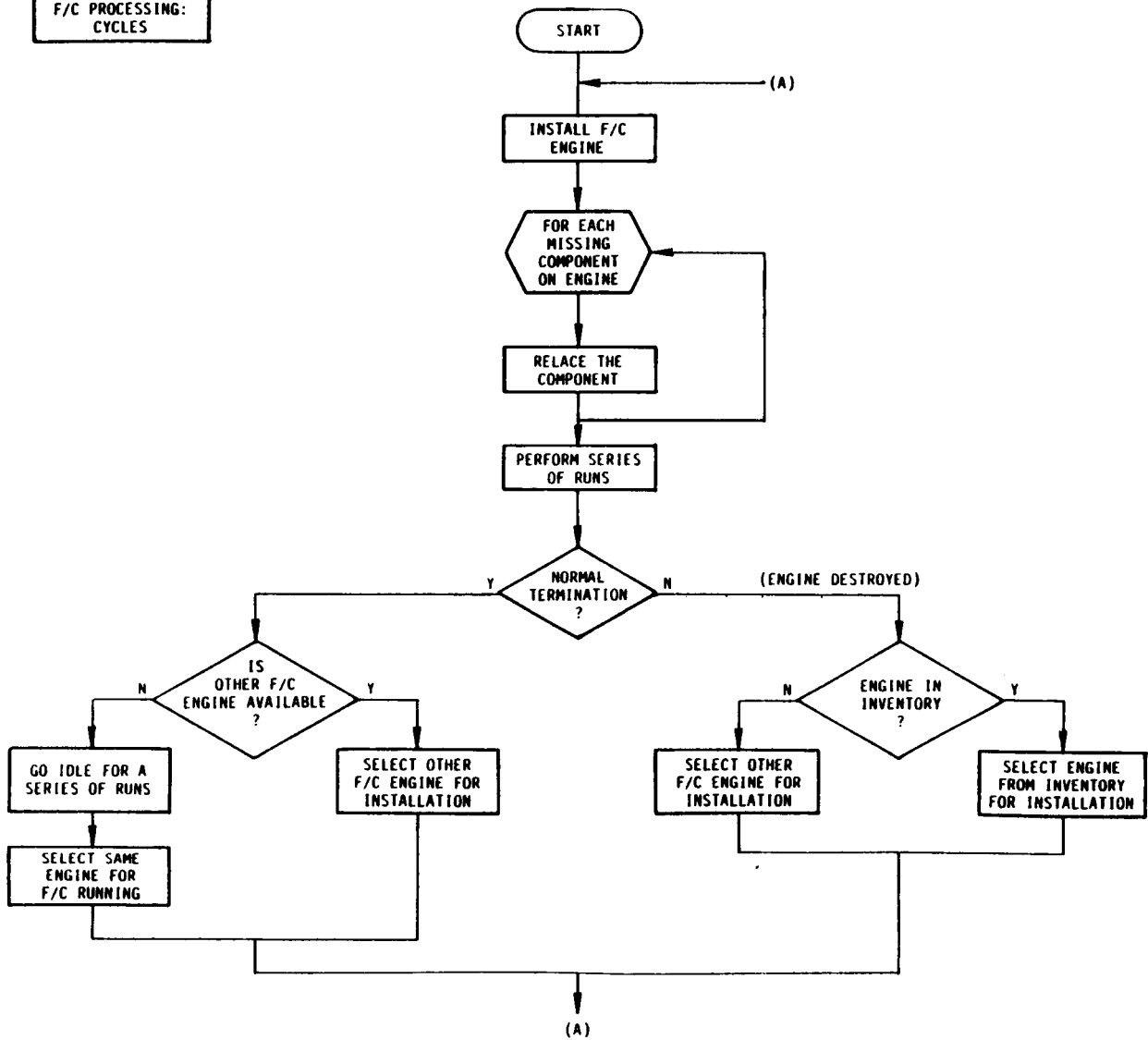

SSME
F/C PROCESSING:
TEST RUNS

