

STUDIES IN THE MECHANICS OF THE TETRAPOD SKELETON

By J. GRAY, Zoological Department, University of Cambridge

(Received 20 December 1943)

(With Fifty-two Text-figures)

CONTENTS

	PAGE
I. General introduction	88
II. The equilibrium of the whole animal in respect of external forces	90
III. The function of the limbs as static supports	97
IV. The equilibrium of intrinsic limb joints	102
V. The equilibrium of the vertebral column	106
VI. The limbs as propulsive units	109
Appendices I, II, III	113
General Summary	115

I. GENERAL INTRODUCTION

Although the individual form of the muscles and bones of a tetrapod body is often known with great accuracy, few, if any, comprehensive attempts have been made to regard the whole system as a complete functional unit. The present studies constitute an attempt to consider the whole vertebrate body as a single mechanical system in which the function of the individual muscles and bones is co-ordinated with those of all, or many of, the others.

From a mechanical point of view, the statics of a tetrapod standing at rest present a complicated three-dimensional system, whilst the animal in motion presents even more difficult dynamical problems. Nevertheless, the animal must conform to mechanical principles common to all animate or inanimate systems. For example, although a horse at rest can, by muscular effort, control the degree of support given by an individual leg towards the support of the body, yet the resultant of the thrusts of all four legs must always represent a force equal in magnitude but opposite in direction to the weight of the animal. In the following pages an attempt is made to reduce the living system to its simplest terms and to consider how far the co-ordination of its various parts can be deduced by purely mechanical arguments. As the general type of analysis is probably unfamiliar to some biologists, it may be convenient, at the outset, to make a comparison between the highly complicated living system with a relatively simple inanimate analogue, and to emphasize the main points in which they resemble or differ from each other. For this purpose, a four-legged table with overhung ends forms a convenient starting-point.

Fig. 1 represents a table resting on four legs, each of which is attached to the top ($ABCD$) by a universal joint (E, F, G, H). Within each leg is an elastic spring (L, M, N, O), and the centre of gravity of the table is assumed to be equally distant from

the centre of each leg. So long as the springs within all the legs are identical in respect of length and elastic properties, each leg will carry one-quarter of the weight of the table and there will be no tendency for the table to rotate about either of the diagonals AC or BD . If, however, the temper of one spring (L) be reduced, the latter will shorten and the table will tip towards that leg; in so doing, the spring (N) under the diagonally opposite leg will extend and the thrust exerted by it against the table will be reduced. Equilibrium will be re-established when the thrusts of the two springs L and N are again equal but less than before the change occurred in spring L . If, however, the thrusts of L and N are reduced, those of M and O must be increased. So long as the legs are vertical and equally distant from the centre of gravity of the table, the general conditions of equilibrium are that the thrust of any one leg must be equal to that of the diagonal leg, and the sum of the thrusts of two ipsilateral legs must be equal to half the weight of the table. Precisely the same arguments apply to the legs of a horse when they are acting as vertical struts (see p. 91), the extensor muscles of the limb being functionally equivalent to the springs within the legs of the table. Further, if in either a horse or table the legs are not vertical and the feet not equally distant from the centre of gravity of the system, it is still possible to define the thrust made by each leg towards the support of the body, by means of equations which are identical in the two cases (§ II).

If the legs of the table are united to the top solely by smooth universal joints the legs can function solely as struts transmitting forces along their mechanical axes only. If all the legs are vertical no horizontal forces are transmitted to the top of the table, but if any leg be inclined to the vertical it will impress on the table-top a horizontal force whose magnitude depends on the amount of weight resting on the leg and on the angle of inclination of the leg's

axis; equilibrium can only exist if this horizontal force is equal but opposite to that impressed on the top by the three remaining legs (see p. 98). If, however, the top of the table is supported by four legs all of which are functioning as vertical or inclined struts, the resultant equilibrium is clearly unstable, since any slight extraneous horizontal force would upset the balance of horizontal forces acting on the top of the table and on each of the legs. Compensation against such forces can be provided by longitudinal (P_1-P_4 ; R_1-R_4) and transverse (S_1-S_4 ; T_1-T_4) elastic braces. Any deformation due to an extraneous median longitudinal force will be resisted by the longitudinal braces, and any median transverse force will be resisted by the transverse braces. Similarly, any extraneous horizontal couple acting on the top of the table can be resisted either by an appropriate co-ordination of longitudinal braces, or of transverse braces, or by a combination of both series. In the case of the tetrapod, the braces are provided by the muscles which unite the limbs to the body. All these muscles operate the limb as a lever enabling it to exert, against the body and the ground, forces at right angles to the limb's own mechanical axis (see p. 99).

If the longitudinal braces in Fig. 1 were all equally powerful they would contribute equally towards the resistance of an extraneous median longitudinal force, but if they are not all equally powerful they will, as passive elastic structures, make individual contributions proportional to their power of resisting extension. If, for example, the combined strength of the longitudinal braces on the right side of the table were not equal to that of the left braces, the table would—when an extraneous median longitudinal force is applied to it—be subjected to a couple which must be resisted by the transverse braces. For practical purposes, therefore, the whole of the musculature which acts between the limbs and body of a tetrapod must be regarded as a single functional unit and not as a series of individual muscles acting more or less independently of each other.

In order that the analogy between the legs of a table and of a tetrapod should be more complete, the straight legs of the former may be replaced by angular structures. If two or more loosely articulated segments are to act collectively as an efficient vertical strut, the joints between the individual segments must be prevented from flexing (under the weight of the table top) by suitable braces tending to extend the individual joints. Such braces are roughly equivalent to the muscles operating about the intrinsic limb joints of the vertebrate. The strain placed on these intrinsic braces or muscles depends partly on the postural angles of the limb bones, partly on the weight carried by the limb, and partly on the forces exerted by the extrinsic longitudinal and transverse braces (see § IV). In other words, there must be, in the case of a vertebrate, a very

widespread pattern of co-ordination between the whole of the limb musculature, both extrinsic and intrinsic.

So far it has been assumed that the top of the table (head, neck, trunk and tail of the tetrapod) is rigid and therefore able to resist deformation either by its own weight, the thrust of the limbs, or the pull of the longitudinal and transverse braces. In the tetrapod the body is composed of segments and consequently it is necessary to consider the effect of dividing the top of the table into a series of hinged units. If a hinge is present at ab , the overhung section $AaBb$ will collapse downwards either under its own weight or under the tension exerted by the braces P_1 and P_2 . In order to prevent this, the hinge must be restrained from moving by some form of longitudinal brace X_1 acting dorsally across the hinge. Similarly, if there is a hinge at cd , the portion ($cABd$) of the table top lying anteriorly to the hinge will tend to move about the hinge under the resultant of all the vertical forces (weight, thrust of the legs and tension of braces) acting on either side of the hinge. This movement must also be restrained by axial braces acting either above (X_2) or below (W) the hinge according to whether the resultant bending forces operate above or below the hinge. Similarly, if the segments of the table top are united together by universal joints, additional braces will be necessary in order to restrain the top from lateral bending and from torsional displacement (see § V).

Sufficient has now been said to illustrate the fact that when a tetrapod is standing at rest with its weight entirely carried by its four feet, the whole of the intrinsic and extrinsic limb muscles, together with those controlling movements of the vertebral column, must be regarded as one functional unit in which the effort of each constituent part is very closely co-ordinated with all the others.

It is now necessary to consider certain features in which the simple mechanical model of the table with its elastic braces differs fundamentally from a living animal. In the case of the table, stable equilibrium is maintained by the elastic braces whose tension depends entirely on their own inherent elastic properties and on the magnitude, direction and point of application of the extraneous forces acting on the table. In the case of an animal, passive braces (ligaments) of this type play a relatively subsidiary role in maintaining stability of the standing posture; effective stability is maintained by muscular tension which is under the control of the animal. If, in the case of the table, one group of braces were to develop spontaneous tension, movements would occur in the system unless either (i) another group of braces developed tension capable of producing effects equal and opposite to those of the first, or (ii) suitable external forces were applied to the whole table. Thus if the retractor group (R_1-R_4) of braces became active the legs would pivot about the feet unless either (i) the protractor (P_1-P_4) braces became active, or

(ii) an extraneous posteriorly acting horizontal force is applied to the top of the table. Clearly, if equilibrium is to be maintained by the effort of internal braces, there must be a definite quantitative relationship between the effort of all the braces concerned. In the case of an inanimate brace or ligament any compensating effort against an external force or against the action of another brace depends on the degree to which it is stretched, but in the case of a muscle the degree of activity is controlled by the more elaborate mechanism provided by its stretch receptors and other reflex mechanisms; as the external strain is increased or decreased so the number of active fibres increases or decreases, thereby enabling the muscle to adjust its effort to the external load without appreciable change of length.

Before proceeding to a more precise consideration of the tetrapod system it is necessary to remember that the muscles of the body and limbs represent mechanical braces of relatively complex morphology. They are not anatomically divisible into separate intrinsic and extrinsic units, since a muscle which extends a knee joint may, at the same time, tend to rotate the limb about the hip. Similarly, a muscle capable of functioning as one of the protractor braces in Fig. 1 may, simultaneously, act also as a transverse brace. The whole of the present studies is, however, based on the fact that so long as the animal is at rest the whole of the musculature can be regarded as a single functional unit whose total action on the limbs or body is such as is expressible in terms of those exerted by the intrinsic springs and extrinsic braces shown in Fig. 1; only in the case of lower vertebrates is it usually necessary to consider rotation of individual limb segments about their own longitudinal axes. Unfortunately there is no generally accepted convention whereby the movements of the vertebrate limb, as a whole, can be defined, although these are somewhat loosely alluded to as extension, flexion, abduction or adduction. In order to avoid confusion a terminology has been adopted for the present work which, although not entirely satisfactory in all cases, enables the movements of a typical tetrapod mammalian limb to be visualized from Fig. 1 without undue risk of ambiguity. If horizontal axes x , x_1 and y , y_1 are drawn parallel and normal to the median longitudinal axis of the body, any muscular effort tending to rotate the whole limb forwards in a vertical plane through kx will be referred to as *protraction*; rotation backwards through the same place (kx_1) being *retraction*. Similarly, any effort tending to rotate the whole limb outwards or inwards in a vertical transverse plane through y , y_1 will be referred to as *abduction* and *adduction* respectively. So far as the whole limb is concerned forces of protraction, retraction, abduction and adduction can only be exercised by muscles whose site of origin lie on the body and therefore lie *extrinsically* to the limb. On the other hand, all muscular effort yielding forces which act solely along the mechanical axis of

the limb itself (i.e. along the axis kx in Fig. 1) is due to elements of the muscular system whose sites of origin lie within the limb itself, and which are therefore *intrinsic* in the same sense as are the springs in Fig. 1 (see, however, p. 103). The terms extension and flexion will be restricted to movements occurring at individual limb joints, other than the hips and shoulders, where risk of ambiguity is absent.

It is necessary to remember that the surfaces of attachment of muscles to bones cannot be represented accurately by points on a diagram and that the tensions developed by the muscles are often very large when compared with the weight of the body; consequently it is usually impossible to draw force diagrams which at all faithfully depict the geometrical relationships of an actual limb. From a theoretical point of view these difficulties are not fundamental, but an analysis which takes them fully into account yields a picture which, on account of its geometrical proportions, tends to mask its own more essential features. At the same time, it is essential to remember the great complexity of the living system and to regard the present studies as an indication of a method available for future experimental attack and not as a complete analysis of an extremely intricate study of three-dimensional mechanics.

Until it is possible to submit them to experimental attack many of the more purely biological inferences to be drawn from a mechanical study of the vertebrate body must be regarded as tentative. Although responsibility for any inaccuracies in these and other conclusions rests solely with the author, any value they possess is due in no small measure to suggestions and help from outside sources. In particular, acknowledgements are due to Mr R. A. Hayes, Dr R. H. Brown and Dr H. W. Lissmann, without whose assistance and constructive criticism the work could not have been pursued.

In order to indicate in general terms the type of biological system to which each mechanical diagram is related, I have at times drawn freely from E. E. S. Thompson's *Studies in the Art Anatomy of Animals* (London, 1896). All outline figures must, however, be regarded as highly diagrammatic and not in any way as representations of particular genera or types.

II. THE EQUILIBRIUM OF THE WHOLE ANIMAL IN RESPECT OF EXTERNAL FORCES

From a mechanical point of view the whole animal can be regarded as a series of bony segments (head, vertebrae, limb bones and girdles) freely hinged to each other and each subjected to the downward pull of its own weight and to the forces exerted on it by its neighbours or by the ground. So long as the animal is standing at rest on its four feet, the general condition of equilibrium is that the resultant of all the other external forces acting on the body as a

whole or on each of its constituent segments should be equal and opposite to the weight of the whole body or of the particular segment as the case may be.

Starting with a tetrapod (Fig. 3) standing on a horizontal surface, the animal as a unit is exposed to five external forces: (i) the weight of the whole system acting vertically downwards through the centre of gravity of the system; (ii) a reaction from the ground exerted at the centre of pressure of each foot; these reactions all have vertical components and may, or may not, have horizontal components due to transverse or longitudinal thrusts exerted by the limbs against the ground. In addition, there may be, in some instances, horizontal couples tending to twist the foot on the surface of the ground. In order that the body should be in equilibrium there must be no resultant force or couple acting about any one of the three main axes of the system. If such axes are taken through a point on the ground (G) vertically beneath the centre of gravity (C) of the body (Fig. 3), movements of the animal along the horizontal axes (XX and YY) and rotation about the vertical (ZZ) axis are solely determined by the horizontal forces or couples acting at the feet; rotational stability about the two horizontal axes (XX and YY) and movements along the vertical axis, on the other hand, are solely determined by vertical forces. If the surface on which the animal is standing is not horizontal the axes of reference can be taken as normal and tangential to the surface of the ground, and the forces acting on the body resolved into components along these axes. So far as the stability of the whole system is concerned, the forces acting normally to the ground can be regarded as a system independent of the forces acting tangentially to the ground.

Distribution of the body weight between the four feet

The ability to stand, on a horizontal surface, with the whole weight of the body carried by the four limbs is characteristic, among living tetrapods, of the Mammalia and of such forms as the chameleons, in which the longitudinal axes of limbs are largely restricted to vertical longitudinal planes passing near or through the shoulders and hips. In most amphibians and lizards part of the weight of the resting animal is carried by the ventral surface of the body: only when the animal is in motion is the whole weight carried by the limbs. In some of the latter types, however, the resting animal can support itself for brief periods with the abdomen out of contact with the ground, and with the four plantigrade feet displaced laterally to unequal extents; such a posture probably represents a more primitive condition than that of a digitigrade mammal and therefore forms a natural starting-point for analytical study. In order that any tetrapod should be in a state of static equilibrium the resultant of the four vertical reactions from the feet must be equal but opposite to the weight of the animal.

This general condition of equilibrium clearly implies that the centre of gravity of the body should lie vertically above a point within a triangle defined by the centres of pressure of three of the feet. For any tetrapod whose four feet are in contact with the ground there are always two such triangles either of which can, from a mechanical point of view, provide adequate support; with the feet in any given positions relative to the centre of gravity of the body the animal can lift either of two particular feet but neither of the other two. The ability or non-ability to lift a particular foot is illustrated in Fig. 4. If the centre of gravity (G) lies within the triangle ABE the animal can lift either of its hind feet, if within BEC it can lift either of the two right feet, if within CED it can lift either front foot, and if within DEA it can lift either of the left feet; only under highly artificial conditions can an animal lift either of the two limbs lying on the same diagonal. An example of these principles is provided by such an animal as a horse whose centre of gravity lies nearer to the shoulders than the hips; if the axes of all the limbs are vertical, the animal can readily stand with either hind limb flexed and therefore carrying no weight; only after initial protraction of all the limbs can the animal lift either front leg. In a rabbit the conditions are reversed and the animal can in its normal standing posture lift either front limb; it cannot lift either of the hind feet. Clearly, the use of the front limbs for functions other than standing or locomotion depends on the position of the centre of gravity relative to the four feet.

So long as the animal is standing on three feet, the contribution of each towards the support of the body weight is definitely fixed in terms of the weight of the body and position of the feet relative to the centre of gravity. If the generalized type shown in Fig. 5 is standing with its right hind-limb off the ground, the contribution (V_1 , V_2 or V_3) made by each of the effective feet can be determined by equations (i)–(iii):

$$V_1 + V_2 + V_3 = W, \tag{i}$$

$$V_1x_1 + V_2x_2 = V_3x_3, \tag{ii}$$

$$V_1y_1 = V_2y_2 + V_3y_3. \tag{iii}$$

In these equations the weight of the animal is W ; x_1 , x_2 and x_3 are the displacements of the feet along the XX axis; y_1 , y_2 and y_3 are the corresponding displacements along the YY axis. Equation (ii) must be satisfied if the animal is not to pitch backwards or forwards about a transverse horizontal axis; equation (iii) must be satisfied if the animal is not to roll about a longitudinal horizontal axis. The values of V_1 , V_2 and V_3 obtained from equations (i)–(iii) are, however, too unwieldy to be of much practical interest and, in practice, an animal is normally supported by four legs and not by three, and therefore it always has two possible triangles of support; by modifying the thrust of its limb muscles the animal can distribute the total load between the

two triangles in any proportion. The general conditions of equilibrium under such circumstances can be visualized by assuming that the animal in Fig. 4*a*, when supported by the triangle (*ABC*) provided by its right fore, left fore and left hind limbs, applies a downward thrust (V_4) against the ground with its right hind foot. If the animal is not to pitch forward about the diagonal *AC*, the moment of V_4 about *AC* must be compensated by an increased thrust (V_3) from limb *B*, and since the total thrust of all four limbs must remain equal to the weight of the body, the thrusts from the right fore and left hind limbs must both be decreased. For an animal standing on four limbs there must therefore be a system of diagonal co-ordination whereby any change in the activity of one limb is accompanied by a similar change in that of its diagonal fellow, together with a change in the opposite direction in the activity of both members of the other diagonal. This important principle can be expressed quantitatively by considering the equilibrium of the system in respect of vertical and horizontal axes drawn at a point on the ground vertically beneath the centre of gravity of the body (Fig. 5). If the animal is not to pitch backwards or forwards about the transverse horizontal axis or roll about the longitudinal horizontal axis the moments of the foot reactions about these axes must be zero. Equilibrium will exist when

$$V_1x_1 + V_2x_2 = V_3x_3 + V_4x_4, \quad (\text{iv})$$

$$V_1y_1 + V_4y_4 = V_2y_2 + V_3y_3, \quad (\text{v})$$

$$V_1 + V_2 + V_3 + V_4 = W. \quad (\text{vi})$$

From these equations the vertical force acting at each of any three feet can be expressed in terms of the force acting at the fourth foot and of the weight of the whole animal. The values so obtained are relatively complex and their real meaning becomes clearer by transferring attention from the generalized tetrapod illustrated in Figs. 4 and 5, to a typical cursorial mammal (e.g. Fig. 6 seq.). In this case $y_1 = y_2 = y_3 = y_4$, and the values for the forces exerted by the right fore (V_1), left fore (V_2) and left hind (V_3) feet become

$$V_1 = \frac{W}{2} - V_4, \quad (\text{vii})$$

$$V_2 = \frac{W}{2} \left(\frac{x_2 - x_1}{x_2 + x_3} \right) + V_4 \left(\frac{x_1 + x_4}{x_2 + x_3} \right), \quad (\text{viii})$$

$$V_3 = \frac{W}{2} \left(\frac{x_1 + x_2}{x_2 + x_3} \right) - V_4 \left(\frac{x_1 + x_4}{x_2 + x_3} \right). \quad (\text{ix})$$

will be noted that when a mammal is standing on three legs equally displaced laterally from the median longitudinal axis of the body, one of the limbs supports half of the weight of the body. Further, so long as $x_2 > x_1$ there are clearly two limiting and positive values for V_4 which permit of

equilibrium, viz. 0 and $\frac{W}{2} \left(\frac{x_1 + x_2}{x_1 + x_4} \right)$. In the first instance the body is entirely supported by the right fore, left fore and left hind limbs, and in the second instance by the right fore, left fore and right hind limbs. In the latter case, however, the pressure (V_1) on the right fore limb is $\frac{W}{2} \left(\frac{x_4 - x_2}{x_1 + x_4} \right)$, and stability is only possible when $x_4 > x_2$. The degree of control which the animal has over its limbs therefore depends on the positions of the feet relative to the centre of gravity of the body. Equations (vii)–(ix) show that if V_4 be reduced, the thrust (V_2) of the left fore limb must be reduced by an amount which depends on the relative position of all the four feet, whilst that of the left hind foot must be increased by a similar amount. Simultaneously, the thrust of the right fore foot (V_1) must be increased by an amount equal to the decrease in V_4 . This general picture is clearly in harmony with that which results from a flexor stimulus applied to one hind limb in either mammals or Amphibia (see p. 93).

An alternative, but very convenient, picture of the co-ordination between the vertical thrust of each of the four limbs of a mammal is provided by a consideration of the right and left limbs acting as pairs (Fig. 6). The resultant of the thrusts of the left fore and left hind feet represents a force equal to half the weight of the animal and acting at a point (*H*, Fig. 6*b*) on the line (*CB*) joining these two feet, the point of action depending on the relative load on the two feet; any increase in the thrust of the left fore foot moves the common centre of pressure of the two feet anteriorly, and any decrease in the thrust of the left fore foot moves the common centre of pressure posteriorly. In order that the whole body should be in equilibrium the common centre of pressure of the two right feet must lie on the line *AD* at a point *I* (Fig. 6*c*) such that the line joining the two centres of pressure (*H* and *I*) passes through *G*, the point at which a vertical line through the centre of gravity of the body meets the ground. Any change which tends to move the common centre of the right limbs anteriorly must be co-ordinated with a change tending to move that of the left limbs posteriorly and vice versa: in other words, any increase in the thrust of one limb involves an increase in that of the diagonal limb and a decrease in both of those on the other diagonal. Alternatively, the state of equilibrium may be defined as that in which any pitching or rolling couple exerted on the animal by the two right limbs is equal but opposite to that exerted by the two left limbs.

On the general principle that an animal is unlikely to stand in such a way as to place unnecessary strain on any individual muscles (see pp. 101 seq.), the extreme limits of variation allowable by equations (vii)–(ix) are unlikely to be observed. If, for any reason, a heavy animal wishes to lift one of its right limbs it may be expected to roll its centre of gravity

the left, thus reducing the thrust required from the remaining right limb. Similarly, any difference between the vertical thrust of the two hind or two fore limbs exposes the vertebral column to longitudinal torsion which must be resisted by the muscles and ligaments of the back (see § V, p. 108); the strain on the latter elements is entirely obviated if the vertical thrust of one hind limb is equal to that of the other whatever be the posture of the feet. This condition is reached in equations (vii)–(ix) when

$$V_4 = V_3 = \frac{W}{2} \left(\frac{x_1 + x_2}{x_1 + x_2 + x_3 + x_4} \right)$$

and

$$V_1 = V_2 = \frac{W}{2} \left(\frac{x_3 + x_4}{x_1 + x_2 + x_3 + x_4} \right)$$

in other words, when the load is distributed between the front and hind feet inversely in proportion to the average distance of the fore and hind feet from the centre of gravity of the body.

It may be noted that in so far as torsional strain is compensated by vertebral muscles and not by ligaments, an animal can, by means of these muscles, control the vertical thrusts of its limbs against the ground. Alternatively, if the torsional forces exerted by the vertebral column are known, an additional equation of equilibrium is available, and therefore the thrust of each of the four legs can be completely expressed in terms of (i) the animal's weight, (ii) the position of the centre of gravity, (iii) the positions of the centres of pressure of the feet, and (iv) the moment of the tension of the vertebral muscles about the centre of rotation of a vertebral joint.

Bipedalism

Fundamentally similar conditions for static stability apply to bipedal forms. In all such cases there are two effective areas of support (heel and toes) provided by each foot, and these four areas can be treated in precisely the same manner as the four individual feet of a tetrapod. If, by voluntary effort of the extensor muscles of the human ankle (see § IV, p. 102) the centre of pressure of one foot is moved forward towards the toes, appropriate action must be taken by the other limb to move its centre of pressure towards the heel. So long as the centre of gravity falls within the rectangle joining the heels and toes the body can be in equilibrium. An example of diagonal co-ordination between the feet of a human subject is illustrated in Fig. 7.

In the case of a bird standing on one foot, two or more triangles of support are provided by the single foot, and for any given effort on the part of the extensor tendon of one digit the effort required from the remaining digits is determinable.

Comparison of mechanical and physiological data

Regarding an animal from a purely mechanical standpoint it is clear that when a cursorial tetrapod

is supported by its four limbs the thrust which any limb exerts normally to the surface of the ground can be varied, between strictly defined limits, without altering either the centre of gravity of the body or centres of pressure of the feet provided that a definite pattern of readjustment is effected in the thrusts exerted by each of the three remaining limbs. Diagonally situated limbs act in unison in the sense that any change in the thrust of one member must be accompanied by a simultaneous change in the same direction of the thrust of the other member; contralateral limbs at the same level of the body act, however, in opposite directions, in the sense that an increase in the thrust of one member must be accompanied by a decrease in the thrust of the other.

The general physiological picture of limb reflexes provides a parallel to that derived from mechanical considerations. Diagonal flexor response to flexor stimulation (which clearly tends to reduce the effective thrust of the limb to which it is applied) was observed in mammals by Sherrington (1906), who also observed an extensor response in both limbs of the other diagonal; comparable phenomena have been recorded for Amphibia by Gray & Lissmann (1940). Similarly, the well-known crossed extensor reflexes between pairs of limbs at the same level of the body conforms to the general mechanical picture. The level of stimulation employed for such observations is usually somewhat drastic, and the results are possibly only comparable to an unstable mechanical situation in which the whole of the weight of the body would be carried on one diagonal pair of limbs. For the maintenance of normal standing postures the necessary co-ordination between the thrusts of the limbs is almost certainly effected by a myotactic mechanism. Liddell & Sherrington (1924) have shown that the tension developed by the extensor muscles of a limb depends reflexly on the external load to which they are subjected. When a right hind limb exerts an increased pressure against the ground, failure on the part of the left fore limb to effect a simultaneous increase would cause the extensor muscles of the latter limb to stretch owing to the downward movement of the left shoulder; this stretch is opposed by the reflex action of the muscles. Similarly, as the load is decreased on the limbs of the other diagonal so the intrinsic activity of their extensor muscles is reflexly decreased. By virtue of this proprioceptive mechanism, each limb acts as an elastic structure exerting a variable thrust equal and opposite to that to which the body is subjected by its own weight and by the thrust of the other three limbs.

The mechanical analysis as given in this paper assumes that when the thrust of one limb is changed the animal does not displace the centre of gravity of the body. If such a change occurs the mechanical picture alters accordingly. The degree of movement of the centre of gravity can only be determined experimentally; actual tests of the behaviour of tetrapods in this respect being impracticable under

existing world conditions, observations derived from human subjects (when supporting the body on hands and knees, the elbows being partially flexed) are of some interest. In order to prevent changes in the position of the centres of pressure of the limb, the weight was carried on the surfaces of the knees and on digits fully flexed. Each limb rested on a spring balance.

(i) For subjects standing normally without conscious bilateral asymmetry of effort, the weight of the body was distributed equally between the right and left pairs of limbs to within 5% of the total body weight, although the posture of individual limbs might vary considerably. Each subject tended to be slightly biased to one side in the sense that a slight excess of weight tended to be carried by one particular side.

(ii) The predictable redistribution of weight between the three remaining limbs was invariably observed when the effort of the fourth limb was consciously changed (Fig. 8).

(iii) For symmetrically placed pairs of limbs (i.e. $x_1 = x_2$, $x_3 = x_4$) the distribution of weight between the fore and hind pairs of limbs was unaffected, although the range of effort of any individual limb might vary by 25% of the total body weight.

From these data it may be concluded that a fairly wide range of posture and of individual limb effort can be exhibited by a tetrapod without altering the position of the centre of gravity of its body. It must be remembered, however, that a voluntary movement of the centre of gravity by simultaneous protraction or retraction of all its limbs enables an animal to vary the distribution of the weight of its body between the fore and hind limbs, while abduction or adduction of all the limbs enables it to redistribute the weight between the limbs on the two sides of the body.

Equilibrium of the body in respect of tangential forces acting at the feet

As pointed out on p. 91, the rotational stability of the whole body about an axis normal to the ground and translocatory stability along the two tangential axes are determined by such tangential forces as may be acting at the feet; so long as the whole animal is standing freely at rest on a horizontal surface the resultant of these forces must be zero. As will be shown in § II, the magnitude and direction of the tangential forces acting at any one foot are under the control of the animal, and in practice the animal probably adjusts their values to such levels as will not place an undue strain on any of the muscles of any one of the four limbs. Any change in the magnitude or direction of the tangential force acting on one foot must, however, be compensated by an equal and opposite change in the resultant of the tangential forces acting at the other three feet. As can be seen from Fig. 9, this adjustment can, in a generalized

tetrapod, be made in a variety of ways and does not involve any fixed pattern of limb co-ordination comparable to that involved by a change in the vertical thrust. In the case of the Mammalia, however, any substantial change in the longitudinal component acting at one foot normally involves an equal and opposite change operating at the other ipsilateral foot.

If a tetrapod is standing on an inclined surface or is, when on a horizontal surface, subjected to an external horizontal force, the resultant of the tangential forces acting between the feet and the ground must be equal and opposite to the tangential component of the weight of the body or to the applied external force as the case may be. In the case of a mammal (Fig. 10) standing freely on an inclined (α) surface, the tangential component of the weight is $W \sin \alpha$ and the component normal to the surface is $W \cos \alpha$, and these forces can be assumed to act at a point (G) on the ground vertically beneath the centre of gravity (C). In order that equilibrium should exist, the combined centres of normal pressure of all four feet must act upwards at G , and exert a total force normal to the ground of $W \cos \alpha$, whilst the resultant of the tangential forces acting at the feet must be equal and opposite to $W \sin \alpha$ also acting through G . If the posture and loading of the feet on the two sides of the body is symmetrical, the normal component ($W \cos \alpha$) of the weight of the body will be distributed between the front and hind feet in a proportion inversely proportional to the distances of the centres of pressure of the feet from the point G (Fig. 10). On the other hand, the distribution of the tangential force (required to neutralize the tangential component of the weight) between the front and hind limbs is, from a mechanical point of view, immaterial; equilibrium can exist so long as half of the total force required is provided by each ipsilateral pair of limbs; if, however, the limbs are all acting as struts (see p. 98), as in Fig. 10, the total tangential force will be divided between the feet in the same proportions as the forces acting normally to the ground. In the absence of claws or other prehensile devices the tangential force exercised by each limb against the ground is opposed by friction and must not exceed a critical value relative to the force which the limb exerts normal to the ground.

In the case of an animal (Fig. 11) standing on a horizontal surface and subjected to an external horizontal force in addition to the weight of the body, the conditions are essentially similar to those of an animal standing on a slope. If the external force tends to pull the body forwards, the effective centres of pressure of the two right and two left feet both move forward, thereby increasing the strain on the front feet and decreasing that on the hind feet. To counteract this effect, the animal frequently protracts its limbs (Fig. 11 *b*), thereby moving the centre of gravity of the body posteriorly relative to the feet.

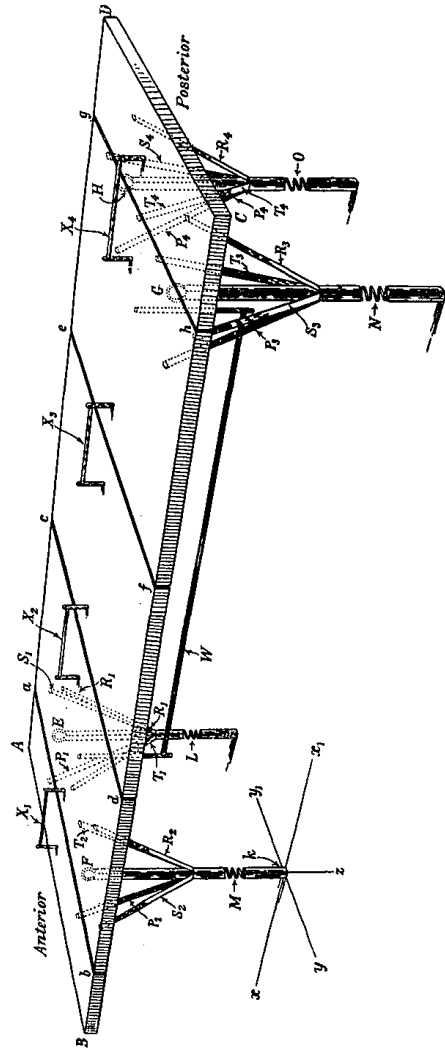

Fig. 1. Diagram of a table illustrating the general relationship between the muscles and skeleton of a tetrapod. The top (ABCD) of the table consists of five segments hinged to each other at *ab*, *cd*, *ef* and *gh*. Adjacent segments are united on their upper surfaces by longitudinal elastic braces (X_1, X_2, X_3 and X_4) attached to pegs rigidly fixed to their respective segments. The second and fourth segments are similarly attached on their lower surfaces by the braces W . Each leg is attached to the top of the table by a universal joint (E, F, G, H) and by fore and aft (P_1-P_4, R_1-R_4) and transverse (S_1-S_4, T_1-T_4) elastic braces. Each leg contains an elastic spring (L, M, N, O) enabling the axis of the leg to be compressed or extended; z_1, y_1 and z_2 are the two horizontal and the vertical axes drawn through the centre of pressure of the left fore leg.

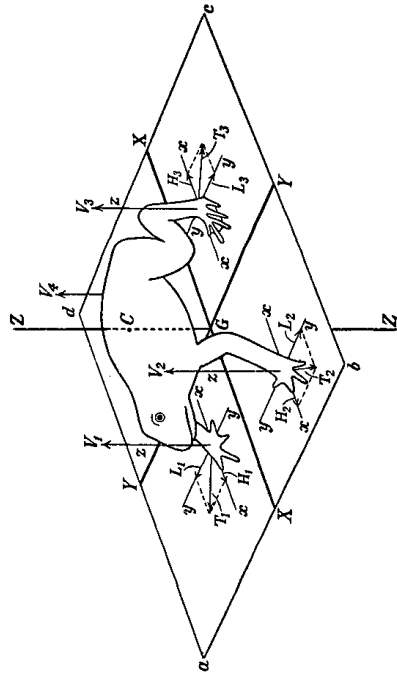

Fig. 3. The animal is standing on a horizontal surface *abcd*, its centre of gravity being at *C*. The reaction of the ground against each foot can be resolved into a component (V_1, V_2, V_3, V_4) acting normally to the ground and into a component (e.g. T_1) acting tangentially to the ground. Each of these tangential components can be resolved into a force acting laterally (e.g. L_1) and into a force acting longitudinally (e.g. H_1). Taking axes of reference (XX, YY, ZZ) through a point (*G*) on the ground vertically beneath the centre of gravity, the general conditions of stability are: (i) the sum of the vertical components of the foot reactions is equal to the weight of the body and the sum of their moments about XX or YY is zero; (ii) the resultant of the tangential components of the foot reactions is zero.

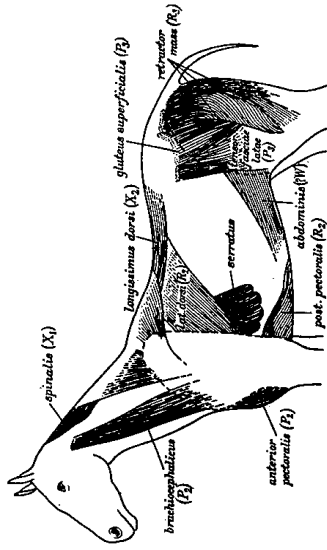

Fig. 2. Diagram showing general comparison of some of the extrinsic limb musculature and axial muscles of the body of a horse to the braces shown in Fig. 1. The letter in brackets after the name of a muscle indicates the type of brace in Fig. 1 to which the muscle is analogous.

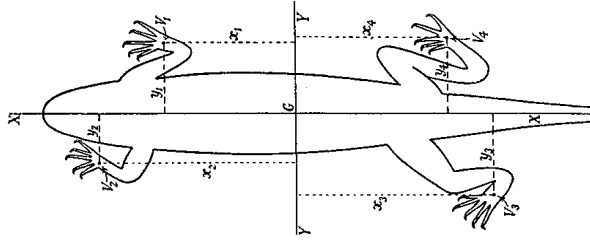

Fig. 5. For equilibrium, the sum of the vertical forces (V_1, V_2, V_3, V_4) acting normally to the ground at each of the four feet must be equal to the weight of the body, and the sum of their moments about each of the axes XX and YY (drawn through the centre of gravity) must be zero.

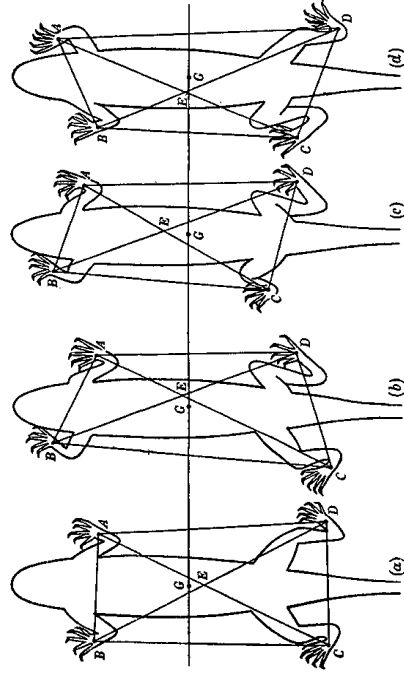

Fig. 4. Diagram illustrating the relationship between the ability to lift a limb and the position of the centre of gravity (*G*) of the body relative to the feet. In fig. *a* either of the hind limbs can be lifted, in fig. *b* either of the right limbs, in fig. *c* either of the front limbs and in fig. *d* either of the two left limbs. The centres of pressure of the feet are at *A, B, C* and *D*; *E* is at the intersection of *AC* and *BD*.

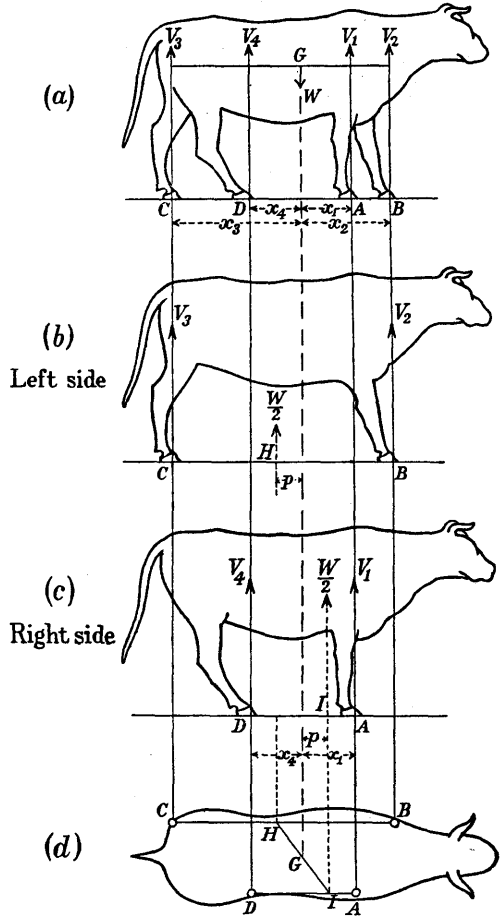

Fig. 6. Diagram illustrating the distribution of weight between the four limbs of a mammal. If the common centre of pressure of the two left feet is at H (fig. *b*) between C and D , and if the centre of gravity of the body is at G (fig. *a*), the common centre of pressure of the two right feet (fig. *c*) must be at I , which is situated anteriorly to the vertical line through G at a distance p equal to the distance to which H lies posteriorly to G . One-half of the weight of the animal is therefore distributed between the two right feet in the proportion $x_1 - p : x_4 + p$.

For a general case, if the longitudinal displacement of each of the limbs from the centre of gravity be x_1, x_2, x_3 and x_4 and the thrust of the right hind limb be V_4 , then the common centre of pressure of the two right feet must be at a distance (p) from the vertical line through the centre of gravity such that $p = \frac{2V_4(x_1 + x_4)}{W} - x_1$. For the whole system to be in equilibrium the common centre of pressure of the two left feet must lie on the other side of the vertical through the centre of gravity at a distance also equal to p . In order that this should be the case the thrust (V_3) of the left hind limb must be $\frac{W}{2} \left(\frac{x_2 - p}{x_2 + x_3} \right)$; substituting for p ,

$$V_3 = \frac{W}{2} \left(\frac{x_1 + x_2}{x_2 + x_3} \right) - V_4 \left(\frac{x_1 + x_4}{x_2 + x_3} \right),$$

a value conforming to equation (ix).

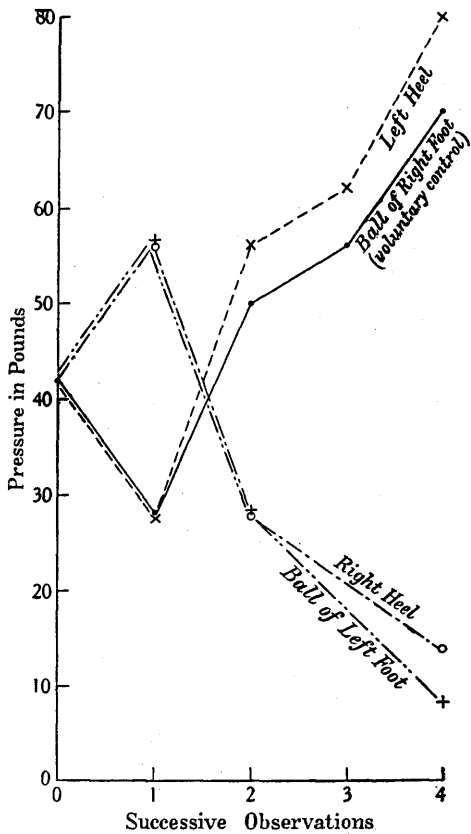

Fig. 7. Graph showing diagonal co-ordination between the distribution of weight between the right heel and left toes (and vice versa) in man. The pressure exerted by the ball of the right foot was controlled voluntarily.

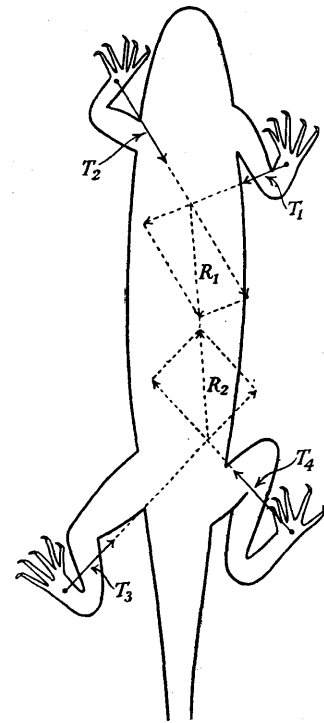
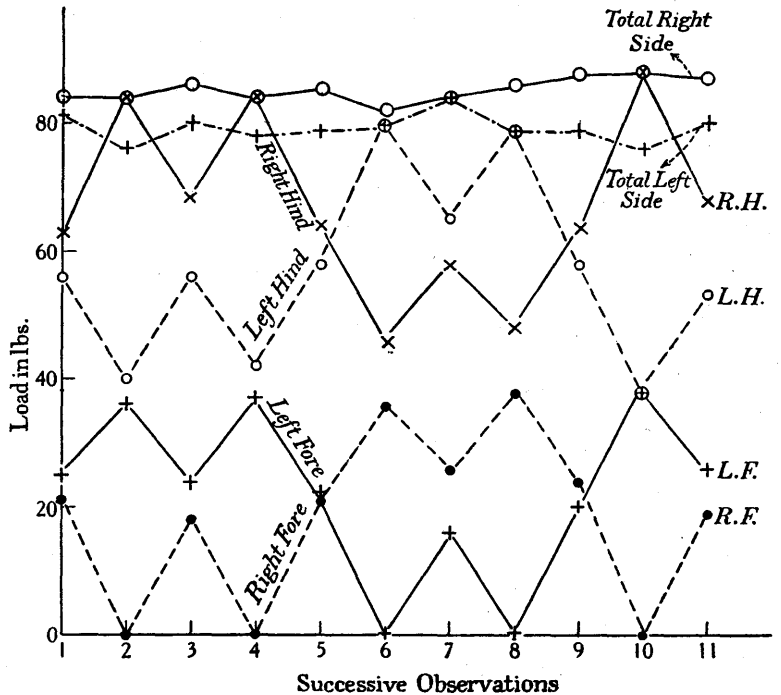

Fig. 9. General nature of equilibrium between the tangential forces acting at the feet. The resultant (R_1) of the forces exerted by the right fore (T_1) limb and left fore (T_2) limb must be equal and opposite to the resultant (R_2) of the tangential forces (T_3 and T_4) exerted by the two hind limbs.

Fig. 8. Graph showing co-ordination between vertical thrusts of diagonal limbs. The data were obtained from a human subject supported on hands and knees, the elbows being flexed. The pressure exerted by the right arm was varied (0-36 lb.) by voluntary control of the extensors of the elbow.



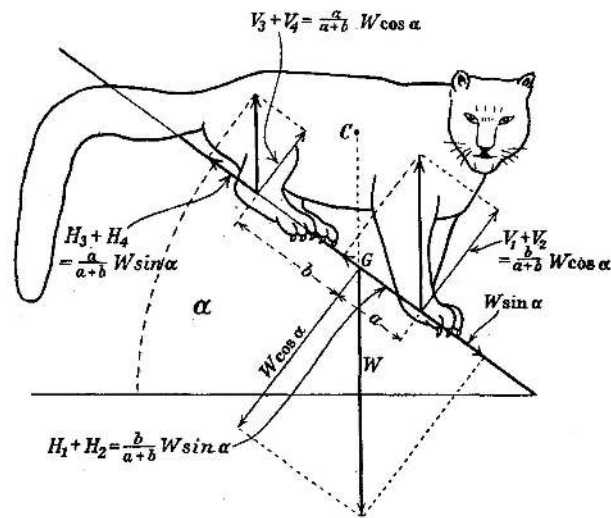
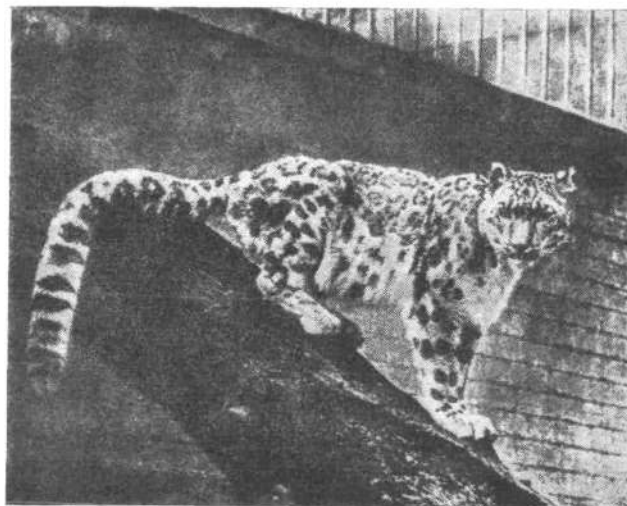

Fig. 10. General conditions of equilibrium for an animal standing (with the two sides of the body symmetrical in posture) on an inclined surface. The resultant pressure of all four feet represents a vertical force equal to the total weight (W) of the body acting at a common centre of pressure at G vertically below the centre of gravity (C) of the body. The normal component ($W \cos \alpha$) of the total body weight is distributed between the front and hind feet in the proportions $\frac{b}{a+b} W \cos \alpha$ and $\frac{a}{a+b} W \cos \alpha$; the tangential component of the total body weight is $W \sin \alpha$ and is opposed by friction acting at the feet. The distribution of the friction between the feet is under the control of the animal but in the figure it is distributed in the same proportion as the normal forces acting at the feet. The lower figure (*Panthera unica*) is a reproduction of a photograph (Tate Regan, 1936).



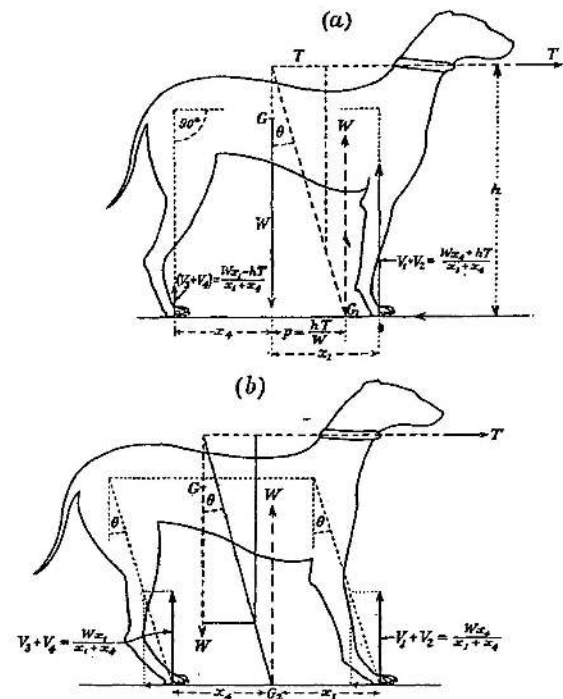

Fig. 11. Effect of an external horizontal force on the distribution of weight between front and hind legs. The animal is assumed to be standing with both sides symmetrical in posture; in the absence of any external horizontal restraint the weight is distributed between the front and hind legs in the proportions $\frac{Wx_4}{x_1+x_4}$ and $W \frac{x_1}{x_1+x_4}$. If, as in fig. a, an external horizontal force T be applied to the body, the resultant of the external forces (T and W) acting on the body cuts the line joining the feet at a point G_1 which lies a distance $p (=hT/W)$ in front of the vertical line through the centre of gravity (G). In order that the common centre of pressure of all the feet should pass through this point the vertical thrust of the front limbs must be increased to a value $\frac{Wx_4+hT}{x_1+x_4}$ and that of the hind limbs reduced to $\frac{Wx_1-hT}{x_1+x_4}$. By protracting all the limbs (as in fig. b) through an angle θ , whose tangent is T/W , the common centre of pressure of the feet moves posteriorly to G_2 and the loading of the feet returns to the value characteristic of the animal standing free from longitudinal restraint with its limbs vertical.

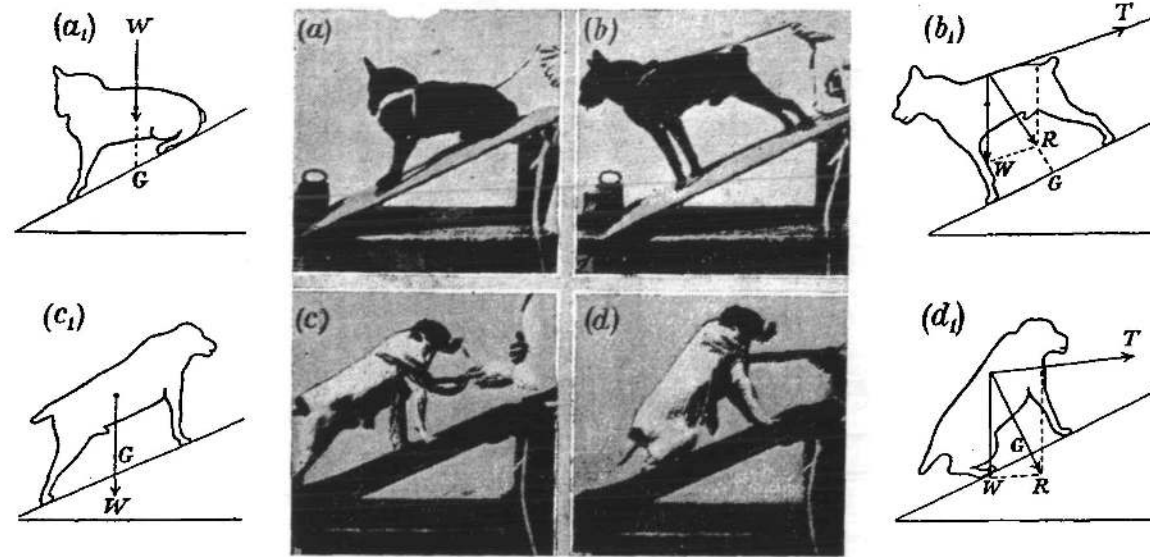

Fig. 12. Postures of a dog standing freely and under restraint on inclined surfaces. (Figs. a-d from Rademaker 1931.)
 a. By lowering the hindquarters the unrestrained animal distributes the load approximately equally between the fore limbs and hindquarters and places no undue strain on the intrinsic limb muscles. When restrained by an extraneous tension (T) as in fig. b, a resumption of the normal standing posture equalizes the load on the limbs; the animal redistributes its weight to counteract the turning couple due to the extraneous tension. Similar principles apply to an animal standing freely or restrained on an ascending surface (figs. c, d).

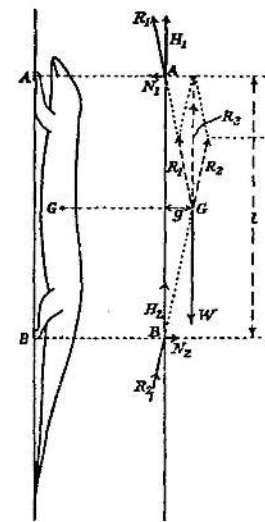

Fig. 14. Equilibrium of forces acting on a lizard adhering to a rough vertical surface. The normal reactions (N_1, N_2) from the wall against the feet provide a couple (N_1, l) equal and opposite to that (W, g) of the weight of the body. The sum of the tangential forces (H_1, H_2) acting at the feet is equal to the weight of the body. G =centre of gravity of the body; R_1 =total reaction of wall against the fore feet; R_2 =total reaction of the wall against the hind feet.

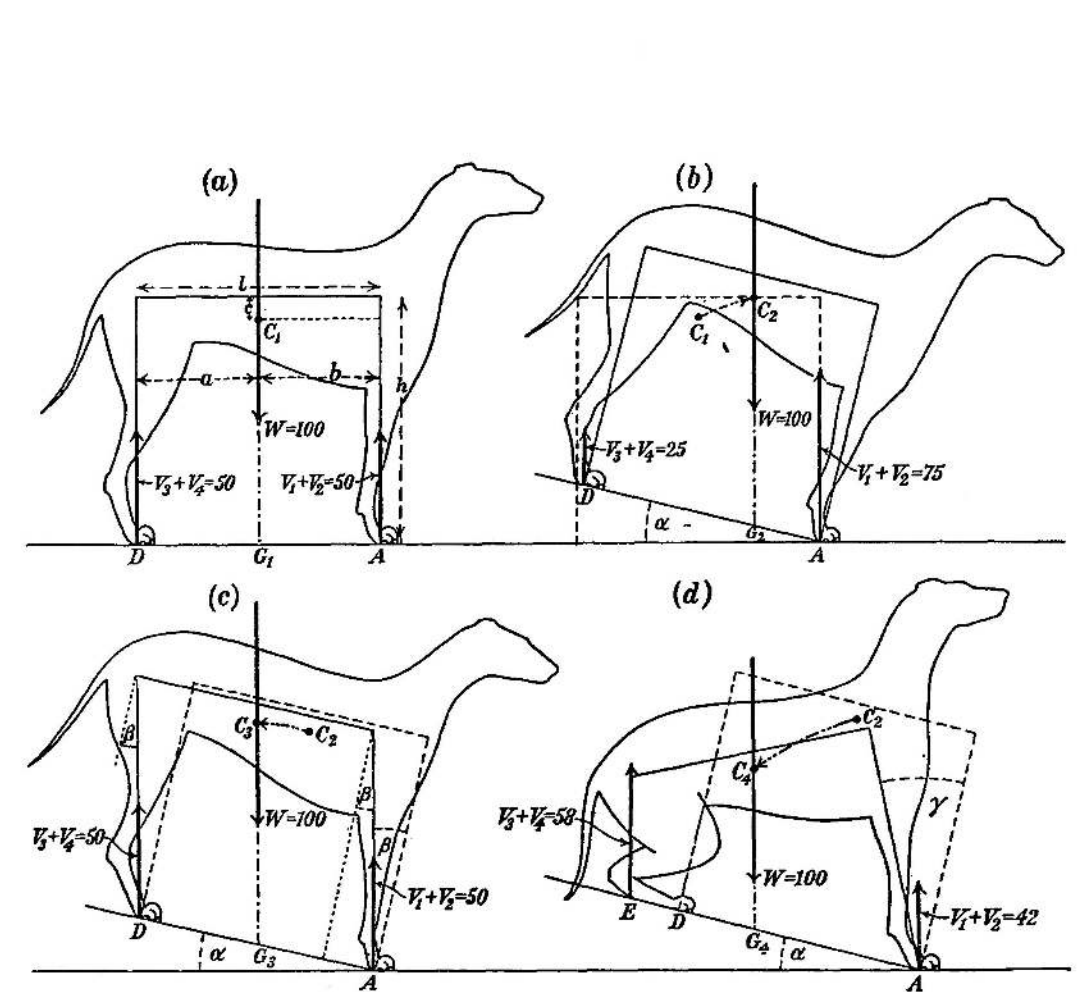

Fig. 13. Postures of a tetrapod mammal standing on inclined surfaces. The centre of gravity is assumed to be equidistant from hips and shoulders and the axes of the limbs are all vertical.
 a. On a horizontal surface the weight of the body is equally distributed between front and hind limbs.
 b. The same animal after the surface has been inclined downwards by an angle α (=approx. 15°). The centre of gravity has moved from C_1 to C_2 . In order that the common centre of pressure of all the feet should act at G_2 the distribution of pressure between front and hind feet must be in the ratio $DG_2 : G_2A$. Three-quarters of weight now rests on the front feet.
 c. The animal has protracted all its limbs through an angle $\beta = \alpha$. The common centre of pressure thus returns to a point G_3 which is equidistant from front and hind feet.
 d. Alternative posture on an inclined slope. The body has pivoted backwards about the front feet through an angle γ and the hind limbs are flexed. The centre of gravity has moved from C_3 to C_4 . If the centre of pressure of the feet remain unchanged the ratio of the loads on the front and hind feet is $DG_4 : G_4A$, thus placing the greater strain on the hind limbs. In practice a heavy load carried at D would place a powerful strain on the extensor muscles of the ankles and consequently the animal readjusts its muscular effort (see § IV) until the centre of pressure of the hind limb lies at E , the distribution of the load is now in the ratio $EG_4 : G_4A$, viz. 42 : 58.

For such an animal (e.g. Fig. 11*b*) the resultant of the forces acting on the body normally to the ground is not zero but constitutes a couple which is equal and opposite to that due to the extraneous horizontal force and the friction at the feet; in this sense the animal uses the weight of its body to counteract the effect of the extraneous force.

Similarly, the application of a suitable extraneous force to an animal standing on a slope may elicit the posture characteristic of the animal when standing freely on a horizontal surface (Fig. 12). In all cases the natural posture is such that the distribution of weight between the front and hind feet conforms closely to that characteristic of an animal standing freely on a level surface.

Scansorial types

An ungulate animal can only stand on an inclined surface if two conditions are satisfied: (i) adequate friction operates at the feet, (ii) a vertical line through the centre of gravity of the body falls within the quadrilateral of the feet. In practice, the animal usually adopts one of two characteristic postures; (i) the axes of the limbs are retracted while that of the body is parallel to the slope (Fig. 12*c*), (ii) the axis of the body is held horizontal by flexure of either the front or hind limbs according to the direction of the slope (Figs. 10, 12*d*). From a systematic point of view, animals living in an environment free from steep slopes are characterized by long ungulate limbs, whilst those adapted to scansorial, or other conditions involving steep slopes, typically possess elongated bodies, with short limbs usually ending in prehensile digits or claws. All these postural and morphological features follow naturally from a consideration of mechanical arguments. Starting with an animal standing with the axes of all its limbs vertical, with its centre of gravity at C_1 (Fig. 13), the total vertical load on the two front feet must be $W \frac{b}{a+b}$ and that on the two hind feet $W \frac{a}{a+b}$, where

a and b are the distances of shoulders and hips from the centre of gravity.* If the surface on which the animal is standing be now inclined downwards at an angle α , the line of action of the weight of the body lies in a vertical transverse plane which cuts the ground at a distance from the front feet (AG_2 , Fig. 13*b*) equal to $a - (h - c) \tan \alpha$, where h is the length of the legs and c is the distance of the centre of gravity below the main axis of the body. In order that the common centre of pressure of all the feet should lie vertically below C_2 the distribution of weight between the front and hind feet must be

$$V_1 + V_2 = W \frac{b + (h - c) \tan \alpha}{a + b}, \quad (x)$$

$$V_3 + V_4 = W \frac{a - (h - c) \tan \alpha}{a + b}. \quad (xi)$$

* In Fig. 13, $a = b$ and the distribution of weight is shown numerically.

Similarly, if the animal is standing on an ascending slope

$$V_1 + V_2 = W \frac{b - (h - c) \tan \alpha}{a + b}, \quad (xii)$$

$$V_3 + V_4 = W \frac{a + (h - c) \tan \alpha}{a + b}. \quad (xiii)$$

Clearly an ungulate cannot stand (with the axes of its limbs normal to the ground) on a descending slope the tangent of whose angle of inclination is greater than $\frac{a}{h - c}$, or on an ascending slope whose

tangent is greater than $\frac{b}{h - c}$.* In order to stand on steep slopes with the axes of the limbs in their normal posture vertical to the axis of the body, it is necessary to have a long body ($a + b$), short legs (h) and a low centre of gravity (c). The more these conditions are satisfied the less danger is there of the animal tipping backwards or forwards about its front or hind feet; the amount of weight $\frac{(h - c) \tan \alpha}{a + b}$

which the slope automatically transfers from front to hind limbs or vice versa decreases likewise. As shown by Fig. 13*c*, however, this transfer of weight is avoided if the animal adopts a vertical posture of its limbs; under these conditions $AG_3 = AG_1$ and consequently the distribution of weight between front and hind limbs is that characteristic of the animal when standing on a horizontal slope with its limbs in the normal vertical position relative to the body (Fig. 13*a*).

On very steep slopes the typical position of rest, particularly of carnivores, is characterized by a horizontal posture of the back (Fig. 10). The mechanical advantage of this position is illustrated by Fig. 13*d*. The animal is assumed to be originally standing on a downward slope (α) and, keeping the axes of the fore limbs normal to that of the body, to have flexed the hind limbs and allowed the body to pivot backwards about the front feet through an angle γ ; as before, the centre of gravity of the body is at C_4 which lies a distance c ventrally to the axis of the body and at distances a and b from shoulders and hips respectively. If the length of the front limb

* If the axes of the limbs are not vertical equations (xii) and (xiii) become

$$V_1 + V_2 = W \frac{b + x_4 - (h - c) \tan \alpha}{a + b + x_1 + x_4}, \quad (xii a)$$

$$V_3 + V_4 = W \frac{a + x_1 + (h - c) \tan \alpha}{a + b + x_1 + x_4}, \quad (xiii a)$$

where $x_1 + x_4$ are the distances by which the fore and hind limbs are displaced outwards from the shoulders and hips respectively. The tangent of the critical angle of the ascending slope is therefore increased to $\frac{b + x_4}{h - c}$; a retraction of the hind limbs in accordance with this principle can be frequently observed in the case of a dog (Fig. Rademaker, Abh. 98).

be h , the distribution of the body weight between the front and hind limbs is

$$V_1 + V_2 = W \left[1 - \frac{(h-c) \sin(\gamma-\alpha) \cos \gamma + a \cos(\gamma-\alpha) \cos \gamma}{(a+b) \cos \alpha} \right], \quad (xiv)$$

$$V_3 + V_4 = W \left[\frac{(h-c) \sin(\gamma-\alpha) \cos \gamma + a \cos(\gamma-\alpha) \cos \gamma}{(a+b) \cos \alpha} \right]. \quad (xv)$$

If $\gamma = \alpha$

$$V_1 + V_2 = W \frac{b}{a+b}, \quad V_3 + V_4 = W \frac{a}{a+b}.$$

muscles of these joints. The fundamental principle however, remains unchanged.

If claws or similar prehensile structures are present on the feet the range of posture on an inclined surface is very greatly increased, since the centre of gravity need not fall within the quadrilateral of the feet and there need be no limiting ratio between the tangential and vertical forces acting at the feet. The general conditions of an equilibrium of this type can be illustrated by a lizard at rest on a vertical but rough surface (Fig. 14). In this case the hind limbs press downwards and inwards against the wall whilst the fore limbs pull downwards and outwards, the

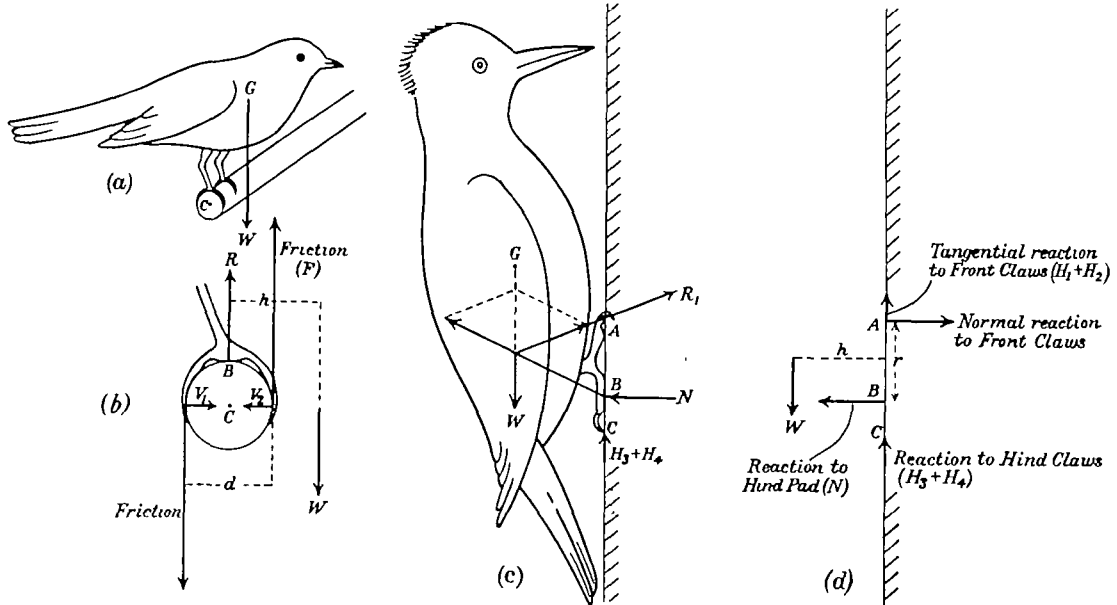

Fig. 15. *a, b.* Equilibrium of forces acting on a perching bird when the line of action of the body weight does not pass through the centre of the perch. The perch exerts at *B* an upward reaction (*R*) equal to the weight of the animal, and the body is subjected to a forward couple Wh ; W is the weight of the bird and h is the distance between the lines of action of R and W . By activity of their flexor muscles, the digits exert equal and opposite pressures (V_1, V_2) normal to the surface of the perch: the magnitude of these pressures must be such that they enable the frictional couple (Fd) to be equal and opposite to that due to the weight of the body (d =the diameter of the perch).

c, d. Equilibrium of forces acting on a bird attached to a vertical surface of a tree. The couple (Wh) due to the weight is balanced by a pull exerted by the anterior digits and a push exerted by the posterior digits, both acting normally to the surface of the tree. The forces acting tangentially to the tree surface (H_1, H_2, H_3, H_4) are together equal to the weight of the bird. The short legs of climbing birds is an adaptation reducing the strain which falls on the muscles of the leg. The precise distribution of the forces over the surface of the foot is somewhat hypothetical; in life the tail may exert a pressure against the tree. R_1 =reaction to front claws; N =normal reaction to posterior digit; H_3 and H_4 =tangential reaction to hind claws; W =weight of animal; G =centre of gravity.

In other words, if the animal stands with its back horizontal, the distribution of weight between the front and hind limbs is the same as when the animal is standing on a horizontal surface with the axes of its limbs vertical. It may be noted that if $\gamma = 0$, equations (xiv) and (xv) reduce to equations (x) and (xi). As pointed out in § IV, this type of adaptation to an inclined surface is usually accompanied by a transfer of the centre of pressure of the hind feet from the toes to the heel (see Fig. 10) in order to avoid placing an undue strain on the extensor

resultant of the reactions of these two forces being equal and opposite to the weight of the body. When in equilibrium, the animal is subjected to two equal and opposite couples, one due to the weight of the body and the tangential vertical forces acting at the feet and the other due to the forces acting at the feet normally to the wall. For such conditions also a long low body represents an adaptive feature. Similar conditions apply to a bird of the woodpecker type (Fig. 15, *c, d*). In the case of a bird standing on a horizontal perch (Fig. 15 *a, b*) any vertical

ple due to the weight of the body is compensated by a frictional couple exerted by the perch against the digits.

SUMMARY OF §§ I AND II

1. The general conditions under which a tetrapod can use any particular limb for purposes other than the support or propulsion of the body depends on the positions of the four feet relative to the centre of gravity of the body.

2. When a cursorial tetrapod is standing on four legs, the contribution which any one limb makes towards the support of the body can vary within limits which can be defined in terms of (i) the weight of the body, (ii) the position of the centres of pressure of the four feet relative to the centre of gravity of the body. If the thrust of one limb is known that of each of the other three can be calculated.

3. If the vertical thrust of any one limb be increased, there must be a simultaneous increase in the thrust of the diagonally situated limb and a decrease in the thrusts of both feet situated on the other diagonal. The reflex myotactic response of mammalian extensor muscles to mechanical stretch provides an adequate mechanism for ensuring effective co-ordination between the vertical thrusts exerted by each of the four limbs. The physiological response of all the limbs to flexor stimulation of any one of them conforms to the mechanical requirements for stability; it probably represents an extreme instance of readjustment of limb thrusts.

4. In bipedal forms a quadrilateral of support is provided by the heel and toes of the two feet: the conditions of stability are essentially the same as in tetrapods.

5. If a tetrapod stands on an inclined slope (in a posture similar to that normally adopted on a horizontal surface) the extent of the resultant redistribution of weight between front and hind feet is inversely proportional to the relative length of body and limbs. A long low body is a mechanical adaptation to a scansorial habit. The typical postures adopted by tetrapods when standing on steep slopes (viz. either with the axes of the limbs retracted or the back horizontal and one pair of limbs flexed) conform to the principle that the distribution of the total weight of the body between the various limbs should approximate closely to that characteristic of the animal standing in a normal posture on a horizontal surface. The same principle applies to the posture adopted by an animal when exposed to restraint by an extraneous horizontal force.

III. THE FUNCTION OF LIMBS AS STATIC SUPPORTS

From a mechanical point of view a tetrapod can be regarded as an elongated body or beam supported by four legs each of which is attached to the beam by (i) a freely movable joint and (ii) a number of extrinsic muscles. For immediate purposes the

vertebral beam will be regarded as a rigid unit and each limb as a telescopic structure capable, by internal muscular effort, of exerting forces along its own mechanical axis, i.e. along the line joining the centre of rotation of the hip or shoulder joint to the centre of pressure of the foot against the ground. Under such conditions each limb can exert on the body (i) a pressure applied by the head of the limb against the centre of rotation of the hip joint or against the serratus muscles, (ii) a tension acting at the site of origin of each of the muscles operating between the limb and the body. Each of these forces can be resolved into three components: (i) vertical, (ii) longitudinal horizontal, and (iii) transverse horizontal. In order that the vertebral beam (body) should remain at rest the following conditions must be satisfied: (i) the sum of all the vertical forces exerted by the limbs must be equal but opposite to the weight of the body, (ii) the sum of the longitudinal horizontal forces must be zero, (iii) the sum of the transverse horizontal forces must be zero, (iv) there must be no residual couple tending to rotate the beam about any of its three major axes. Precisely similar conditions apply to each limb except for the fact that the reaction from the ground represents an additional force acting on the system. The whole system and each of its five component parts clearly represent a relatively complex study in three-dimensional statics. If, however, attention be focused on typical mammalian limbs rather than on the more generalized conditions found in lower vertebrates, the problem can be very greatly simplified without serious limitation in the application of the results.

From a mechanical point of view the typical mammalian limb has three main advantages: (i) the mechanical axes of both ipsilateral limbs lie in approximately the same vertical plane, (ii) the forces tending to displace the limbs or body backwards or forwards are considerably greater than those tending to displace them laterally, and (iii) forces tending to rotate the limb about its longitudinal mechanical axis can be neglected so long as the animal is at rest. Consequently, it is possible to analyse the mammalian system very largely in terms of vertical and horizontal forces all acting in two longitudinal vertical planes. This treatment yields a mechanical picture of the whole system which, although relatively simple, nevertheless leads to the same fundamental conclusions as those derived from the much more complex three-dimensional system presented by the limbs of the lower vertebrates. Further mechanical simplifications can be effected by taking advantage of the fact that the principles whereby a limb is maintained in equilibrium with its own weight are fundamentally the same as those which maintain its equilibrium with the weight of the body (see Appendix I, p. 112); by ignoring the weight of the limb, a much clearer conception of limb function can be obtained and, if a complete picture is required, it is always possible to superimpose that

derived from a consideration of the limb's own weight.

So long as the above simplifications are borne in mind each limb of a mammal, standing at rest, can be regarded as a system in equilibrium with three forces: (i) the force exerted by the body against the head of the limb at its effective centre of articulation with the body, (ii) the tensions exerted on the limb by the extrinsic muscles which unite the limb to the body, and (iii) the reaction of the ground against the foot. If the resultant of all the extrinsic muscular tensions is zero, the limb acts as a strut transmitting forces along its own mechanical axis only. If, on the other hand, the resultant tension of the extrinsic limb muscles is not zero, the limb exerts forces at right angles to its own mechanical axis and, to this extent, functions as a lever. During the earlier part of the ensuing discussion the whole musculature of the limb will be regarded as having the functional components, one being solely concerned with the operation of the limb as a strut and the other with its operation as a lever. Subsequently, the action of definitive muscles in each or both of these capacities will be considered.

Function of the limb as a longitudinal strut

In the simplest mechanical case (Fig. 16) all four limbs function as vertical struts in the sense that the centre of pressure of the ground against each foot lies vertically beneath the centre of rotation of the hip or shoulder. As shown in § I, the vertical thrust from any individual limb can, by internal muscular effort, be varied between certain well-defined limits which depend on the relative distances of the front and hind feet from the centre of gravity of the body. In every case, however, the resultant of the external forces acting on each limb and on the body must be zero if the whole system is to remain in equilibrium.

In a great many postures, however, one or more limbs may be inclined to the vertical to such an extent that the vertical line of action of the body weight acting at the hip or shoulder falls outside the surface of the foot (Fig. 17). If such a hind limb is to act as an efficient inclined strut its axial thrust must be such as will produce a vertical upward force at the hip equal to the weight of the body acting at that joint. If this weight be W_4 , the axial thrust of the limb must be $W_4 \sec \alpha$, where α is the angle of inclination of the limb's axis. Such an axial thrust will, however, exert at the hip a horizontal force $W \tan \alpha$, and a horizontal force of equal value but of opposite direction will be exerted by the foot against the ground. Such a limb can only be in equilibrium if the body exerts against the head of the limb a compensating horizontal force ($H_4 = W_4 \tan \alpha$ (Fig. 17a)) and if, at the same time, the horizontal component of the limb's thrust against the ground is opposed by an equal and opposite tangential resistance (e.g. static friction) from the ground. It may be noted that when a limb is supporting the body in

the capacity of an inclined strut, the head of the limb is subjected to two equal and opposite turning forces, one attributable to the weight of the body and the other to a horizontal force exerted on the head of the limb by the body. Similarly, the limb is subjected at its foot to two equal but opposite turning forces, one due to the reaction of the ground to the weight of the body and the other to friction acting between the foot and the ground.

A simple case in which all four limbs function as struts is shown in Fig. 18. Since each limb is assumed to be carrying one-quarter of the total body weight, the right hind and left fore limbs exert anteriorly directed forces against the body each equal to $\frac{1}{4}W \tan \alpha$, where α is the angle of inclination of the limb to the vertical; the horizontal forces exerted by the left hind and right fore limbs are directed posteriorly and also each equal to $\frac{1}{4}W \tan \alpha$. The resultant horizontal thrust of all the limbs against the body is zero and the latter is therefore in equilibrium. So far as any one limb is concerned, the horizontal component of its own axial thrust is equal and opposite to the resultant of all the horizontal forces exerted by the remaining limbs on the body. The right side of the body is under compression whilst the left side is under tension; in other words, the hips are exposed to a longitudinal horizontal couple (H_3, H_4 , Fig. 18d), whilst an equal but opposite couple (H_1, H_2) acts on the shoulders. As will be shown later (§ V), these couples must be compensated by activity of the vertebral muscles. For the time being, it may be noted (Figs. 18 b, c) that as in this particular example the load on each foot is equal to that on the contralateral limb (at the same level of the body) the vertebral column is free from torsional stress (see p. 108, § V).

If the two left limbs in Fig. 18 were to adopt the posture already adopted by the two right limbs the system would still be in equilibrium, since the combined anterior thrust imparted to the body by the hind limbs would be equal and opposite to the posterior thrust of the front limbs and vice versa. Neither hips nor shoulders would be exposed to turning couples, nor would the body be exposed to a lateral bending couple: on the other hand, the neutral axis of the vertebral column would be compressed.

It is clear that a limb can, in the capacity of an inclined strut, contribute effectively towards the support of the body provided that (i) the horizontal component of the axial thrust applied to the body by means of the limb's own intrinsic extensor muscles is equal but opposite to the resultant horizontal force exercised on the body by the other three limbs or other external agencies, (ii) friction, equal in value to the horizontal force exerted by the body against the head of the limb, acts at the foot. Any change in the distribution of the weight resting on a limb alters the horizontal thrust which must be forthcoming from the other limbs in order to sustain the limb as a strut.

Limbs as lateral struts

The ability of a limb to act as a lateral strut depends on precisely the same principles as determine its action as a longitudinal strut. An example of transverse struts is shown in Fig. 19, which also indicates one of the equilibrium conditions applicable to the pectoral limbs of many reptiles and to firmisternal Amphibia. It will be noted that the equilibrium of the limbs when acting as inclined lateral struts depends on the ability of the shoulder girdle and body to resist transverse compression. Conversely, in arciferous forms compression of the thorax by laterally displaced limbs can usually only be avoided by using these limbs as levers operated by their pectoral musculature.

In typical cursorial mammals the power of a laterally displaced limb to support a substantial amount of the body weight is often limited, but since some degree of lateral inclination of the limb is possible, transverse forces will operate between the limbs and the body. So far as a limb acts as a strut any transverse horizontal turning couple, due to the weight of the body, must be compensated by (i) a transverse horizontal force, due to the action of the other three limbs, applied by the body to the head of the limb, and (ii) transverse friction acting at the feet. In the case of the body, transverse and longitudinal horizontal couples must be considered together. Any unbalanced horizontal longitudinal couple due to the limbs acting as longitudinal struts will tend to rotate the body about its vertical axis; this can, however, be compensated by a suitable horizontal transverse couple due to the limbs acting as transverse struts. An example is given in Fig. 20.

The operation of the limbs as struts involves no differential activity on the part of the muscles by which the limb is attached to the body. If, however, the whole of this musculature were free from tension the resultant equilibrium of the hip and shoulder joints would be unstable in the sense that it would be upset by very small extraneous forces. During life, the whole of the limb musculature displays a definite degree of tonic contraction, but so long as a limb is acting as a strut the rotary effect of any one group of muscles tending to rotate the limb about the hip or shoulder is opposed by the equal and opposite effect of an antagonistic group; the effect of all the rotary muscles is, under such conditions, restricted to a compression of the head of the limb against the body along the mechanical axis of the limb, the resultant turning effect of all the muscles being zero.

If the body is exposed to an extraneous horizontal force, displacement in respect to the limbs can only occur if one or other group of rotary muscles is stretched. In this case the muscles exert a turning action on the limbs tending to oppose the action of the extraneously applied force; the limbs then act as levers. Similarly, if the horizontal force exerted on the head of a limb by the body is not equal but

opposite to the horizontal component of the axial thrust from the limb itself, the difference must be made good by the limb's action as a lever. Difference in longitudinal horizontal forces must be compensated by longitudinal protractor or retractor muscles and differences in transverse horizontal forces by abductor or adductor muscles.

The limb operating as a lever

When a muscle, by which a limb is united to the body, is under tension it tends to rotate the former about its proximal joint and enables the foot to exercise, against the ground, a force at right angles to the limb's own mechanical axis. In such circumstances the limb can be regarded as a lever whose fulcrum is represented by the centre of rotation of its proximal joint.

The mode of action of such a muscle is illustrated in Fig. 21*a*, in which a protractor muscle is developing tension between its origin (*O*) on the body and its point of attachment (*A*) on the limb. The tension (T_B) exerted on the body at *O* can be resolved into components normal (*OP*) and along (*OQ*) the line (*OH*) joining the effective point of origin of the muscle to the centre of rotation of the hip. The force acting along this line can be replaced at *H* by a force ($HR=OP$) acting at right angles to *OH* and by a force ($HS=T_B$) acting parallel to the line of action of the muscle. The two forces *OP* and *HR* constitute a couple acting on the body and tending to rotate its anterior end downwards, whilst the two forces *HS* and T_L constitute a couple acting on the limb and tending to rotate the head of the limb backwards and the foot forwards. The moment of the couple acting on the body is equal but opposite to that acting on the limb, whilst both are numerically equal to that of the muscle's tension acting about the joint (see legend to Fig. 21). The application of these equal and opposite couples to the body and limb is the fundamental action of all muscles which act between the body and limbs, for, by adjustment of their tension the limb can be stabilized either against a turning action due to the weight of the animal or of a horizontal force applied to the head of the limb by the body. For a limb subjected at its proximal end simultaneously to a vertical force (V_4) due to the weight of the body and a horizontal force (H_4) due to a thrust exerted by the axis of the body, equilibrium will exist when the sum of the moments of these forces about the foot is equal but opposite to that of one (Tx) applied by the limb's own extrinsic muscles,

$$V_4 l \sin \alpha + H_4 l \cos \alpha = Tx,$$

where V_4 = vertical load on the limb, l = length of the limb and α is its angle of inclination to the vertical, H_4 = horizontal thrust of the body against the hip or shoulder, T = tension of the muscles operating between the body and limb, and x = working distance of muscles from the joint. Clearly, if

$H_4 = -V_4 \tan \alpha$, the limb acts as a strut, but for any other value of H_4 equilibrium is dependent on the limb operating as a lever. Similarly, as long as the vertical load on a limb remains fixed, any alteration in the tension of a protractor or retractor muscle alters the value of the longitudinal friction acting at the foot and the horizontal longitudinal thrust which the head of the limb exerts against the body. Precisely similar considerations apply to limbs acting as transverse levers when operated by adductor or abductor muscles. So far as longitudinal horizontal forces are concerned, control is exercised by the protractor and retractor muscles of the hips and shoulders; protractor muscles exert posterior forces on the body and retractor muscles exert anterior forces. In each case corresponding frictional resistance must act against the foot.

The total vertical force exerted by a limb against the body or ground is the sum of those due to the limb acting as a strut and as a lever; similarly, the total horizontal force exercised against the body and the ground is also the sum of the effects of the limb as a strut and a lever. The vertical leverage of the limb is, however, usually comparatively small so that the main strain falls on the axis of the limb. On the other hand, the muscles which unite the limb to the body may be regarded as the only mechanism whereby the animal can influence the horizontal forces acting on the body without disturbing the distribution of weight between the various feet. From a morphological point of view, the division of the limb musculature into two separate units (one which is solely concerned with the maintenance of forces acting along the mechanical axis of the limb and the other with horizontal forces acting against the body and against the ground) is, at first sight, confusing if not misleading; at a later stage (see p. 103), however, this difficulty will be shown to be more apparent than real. For a more detailed consideration of limbs acting as levers, see Appendix II, p. 113.

Interaction of adjacent limbs

A picture of the interaction between the limbs of a tetrapod can be obtained from Fig. 22, in which the two sides of the animal are assumed to be symmetrical in posture and vertical loading of the limbs; the angles of inclination of the front limbs (α) are not the same as those (β) of the hind limbs. In order that equilibrium should exist, the weight of the body must be distributed in accordance with the principles defined in § I, and since the loading is symmetrical on the two sides of the body the relative loads carried by the front and hind limbs must be inversely proportional to the distances of the feet from the centre of gravity of the body. In the absence of horizontal transverse forces, the longitudinal horizontal thrust applied to the body by one limb must be equal and opposite to that applied by its ipsilateral fellow. If the vertical loads on the

right fore and right hind limbs are V_1 and V_4 , the fore limb in its capacity as a strut exerts a posterior horizontal thrust to the body equal to $V_1 \tan \alpha$, where α is the angle of inclination of the limb's axis; similarly the hind limb exerts an anterior thrust equal to $V_4 \tan \beta$, where β is the angle of inclination of its axis. If the system is to be in equilibrium this inequality must be compensated by extrinsic muscular action; if (as in the figure) $V_4 \tan \beta > V_1 \tan \alpha$ this muscular action must be such as to apply a posterior longitudinal force to the body and posterior friction at the feet. Compensation of this type can be effected in a variety of ways.

(i) The protractor muscles of the front limb can exert a posterior thrust (H_{FP}) to the shoulder (and elicit posterior friction at the front foot) such that $H_{FP} = H_4 - H_1$; the hind limb functions solely as a strut (Fig. 22*a*).

(ii) The protractor muscles of the hind limb can reduce the anterior thrust exerted by this limb as a strut by developing a posterior force (H_{HP}) at the hip (and at the foot) such that $H_{HP} = H_4 - H_1$; the fore limb functions solely as a strut (Fig. 22*b*).

(iii) The protractor muscles of both limbs can co-operate in varying degrees so long as the horizontal forces which they exert are such that

$$H_{FP} + H_{HP} = H_4 - H_1.$$

In each of these three cases the total muscular effort is clearly the same.

(iv) Each limb can by its own extrinsic musculature reduce its horizontal thrust against the body and against the ground to zero. In this case the protractor muscles of the hind limb must exert a force (H_{HP}) equal and opposite to H_4 , and the retractor muscles of the fore limb must exert a force (H_{FR}) equal but opposite to H_1 (Fig. 22*c*); again the net posterior muscular thrust is $H_4 - H_1$, although the total muscular effort is $H_4 + H_1$.

(v) The forward thrust of the hind limb can be increased by activity of its retractor muscles (Fig. 22*d*): in this case the effort required from the protractor muscles of the front limb must be correspondingly increased also.

At first sight it might appear that the states of equilibrium shown in Fig. 22*c* and *d* are wasteful of effort; it will be shown later that they are of considerable functional interest. For the moment, however, it should be noted that for any given position and loading of the feet the minimum muscular effort essential for equilibrium is always the same, but its distribution between the various muscles is under the control of the animal. Without altering the vertical loads being carried by the limbs and without altering the position of its feet an animal can transfer the strain from one muscle to another. Before considering further the functional significance of this conclusion, it is convenient to note that the range of muscular activity conformable with equilibrium can be still further widened by changing the

Distribution of the body weight between the four limbs. For example, if the vertical thrust of the right hind limb is suitably reduced and that of the right front limb increased, these two limbs can (as in Fig. 23*a*) act as struts, whose common centre of pressure (G_1) lies anteriorly to the line of action (G) of the body weight; equilibrium in respect to vertical forces can exist so long as the common centre of pressure (G_2) of the two left feet lies posteriorly to G and $GG_1 = GG_2$ (see Fig. 23*b*). This can be effected by adjusting the vertical thrusts of the two left limbs; if, now, the left front limb acts as a strut the friction acting at the foot will be $V_3 \tan \alpha$, whilst that of the left hind limb will be $V_3 \tan \beta$. If the right hind, right fore, and left fore feet are all acting as struts the left hind limb will be in equilibrium as long as its extrinsic muscles compensate the difference $V_3 \tan \beta - V_3 \tan \alpha$. The animal shown in Fig. 22 or 23 can therefore stand in equilibrium without strain of any of its extrinsic limb musculature apart from that of the left hind limb. In other words, by modifying the distribution of weight between the various limbs an animal can transfer strain on its extrinsic muscles from one side of the body to the other. In every case the total amount of muscular strain borne by the muscles is the same.

In the above examples it is assumed that the limbs do not exert horizontal transverse forces against the body. As already pointed out, however, a horizontal longitudinal couple applied to the body by the limbs can be compensated by a horizontal transverse couple due to the limbs acting as transverse levers under the action of adductor or abductor muscles. From all these facts it is obvious that for any given standing posture the strain which is placed on the musculature by the weight of the body can be distributed in a variety of ways and that, for this reason, the whole of the musculature must be regarded as a single functional unit and not as a series of separate muscles each playing a more or less independent role. This conclusion is probably not unrelated to the fact that many mammals can stand for long periods without fatigue. As will be shown elsewhere, the picture of the whole of the limb musculature as a single functional unit also applies to the animal in motion; as shown by Stewart (1938) very extensive muscular excision can be effected before the animal loses its normal locomotory gait.

Distribution of muscular effort in relation to function

From the above analysis it is clear that there is a wide but definable range of muscular patterns within which the mechanical requirements of any standing posture can be met. It is also clear that the actual strain imposed on the musculature of a joint could be defined if the magnitude and direction of the reactions of the ground against the feet were known: these values can only be obtained experimentally.

Pending the availability of such data the following considerations are of some interest.

(i) *Limiting angle of friction.* If an animal is standing on ice little or no friction can operate at the feet, and no horizontal thrust can be transmitted from one limb to another by the vertebral column; each limb must be completely stabilized against the weight of the body by the activity of its own extrinsic musculature (Fig. 22*c*). In a less extreme case, the amount of friction required to stabilize a limb must not exceed that permitted by the limiting coefficient of friction between the foot and the ground—in other words, the inclination of the limb must not exceed a critical value before its extrinsic muscles come into play. If, however, the limb is able to engage the surface of the ground with claws or other devices there need be no such limit to the degree of protraction or retraction of the limbs (see, however, §§ IV and V).

(ii) *Equitable distribution of muscular strain.* On general grounds it may be assumed that an animal will not adopt a pattern of muscular activity which places an undue strain on any of the muscles concerned; in other words, it will tend to adopt a pattern which distributes the strain between the muscles in proportion to their ability to develop and sustain tension. For example, in Fig. 22*a* the whole strain falls on the protractors of the fore limbs and none on the retractors of the hind limbs. In Fig. 22*b* the situation is reversed, and, as already explained, the strain can be distributed between these two groups of muscles in any proportion. In other words, by voluntary contraction of one of these groups the other can be partially or completely relieved of all strain. On the other hand, as in Fig. 23, the strain can be distributed in various proportions between the two sides of the body. In the absence of observational data, it is impossible to say which particular pattern of muscular activity will be adopted, but it may be presumed that for any given posture of limbs the animal will adopt a pattern wherein the relative strain falling on each group of muscles will bear some relationship to its strength. Just as the moment of the reaction at the foot about the hip or shoulder joint is a measure of the strain placed on the muscles of these joints, so the strain on the other joints of the limb is also determined by the moment of the foot reaction about these joints. This aspect of limb stability will be considered elsewhere (see §§ IV and V). In general it may be said that the most 'comfortable' pattern of muscular activity, within the possible range of equilibrium, will probably be that in which the reaction from the foot passes closest to the limb joint whose extrinsic musculature is weakest.

The correlation of standing posture with an economical distribution of strain between the relevant muscles has already been noted in the case of an animal standing either freely or under restraint on an inclined surface (see p. 95).

SUMMARY

1. The limbs of a tetrapod can contribute towards the support of the body either in the capacity of struts or in the combined capacity of struts and levers. When acting as a strut a limb exerts forces along its own mechanical axis only, the moment of the muscular tensions operating about the hip or shoulder joint being zero. When a limb is acting as a lever the limb exerts both against the body and against the ground forces at right angles to its mechanical axis; it is able to do so by means of the muscles whereby the limb is attached to the body.

2. When a limb is acting as an inclined strut the couple which is exerted on it by the weight of the body must be compensated by a couple due to (i) a horizontal force exerted on its proximal end by the body, and (ii) friction or other horizontal force acting at the foot. The horizontal force acting at the proximal end of the limb represents the resultant horizontal force exerted on the body by the three other limbs. Instances are described of two or more limbs co-operating, either as longitudinal or transverse struts, for the support of the body.

3. When subjected to tension from a muscle originating on the body, a limb operates as a lever and exerts equal but opposite horizontal forces against the ground and against the body. At the same time it exposes the body to a turning couple whose moment is equal to that of the muscle's tension about the centre of rotation of the joint. If the weight of the limb be neglected, the resultant of the horizontal force and couple applied to the body by the muscle is equal in direction and magnitude to the horizontal force exerted by the ground against the foot.

By means of the muscles which operate between the body and the limb an animal can control the horizontal forces exerted by a limb against the body and against the ground. The magnitude of the vertical force exerted by a limb against the body is almost entirely controlled by muscular effort operating along the mechanical axis of the limb.

4. The muscular co-ordination between two or more limbs, acting as levers, is described. For any given position of the feet relative to the centre of gravity of the body, the minimum total muscular effort required to maintain equilibrium is always the same. The distribution of this effort between the muscles of the various limbs can, however, be varied between relatively wide limits, either by changing the tension of one or more extrinsic muscles or by changing the distribution of weight between the feet by a change in the axial thrust of the limb. The whole of the limb musculature of the animal must be regarded collectively as one functional unit.

5. The particular pattern of muscular activity adopted for any given posture and loading of the limbs is probably such that the strain is distributed between the relevant muscles in proportion to their ability to develop and sustain tension.

IV. THE EQUILIBRIUM OF INTRINSIC LIMB JOINTS

The arguments developed in the previous section are based on the assumption that each limb can be regarded as a telescopic structure capable of exerting a longitudinal axial thrust and of acting as a lever when operated by the muscles by which the limb is attached to the body. The tetrapod limb is, however, essentially a series of articulated rods whose joints possess little or no natural rigidity and whose ability to resist bending forces depends almost entirely on the activity of their associated muscles. It is therefore necessary to consider the type of internal muscular effort which enables the limb as a whole to function as an efficient strut or lever.

From a mechanical point of view the whole limb can be regarded as a series of hinged rods in equilibrium with three groups of external forces: (i) the forces exerted on the limb by the body, (ii) the force exerted by the ground against the foot, (iii) the weights of the individual limb segments. Since the mechanism whereby rigidity of the limb is preserved in respect to the weights of the limb segments is essentially the same as that in respect to the forces exerted on the limb by the body (see p. 105) it is possible to simplify the system and consider the limb, at rest, as in equilibrium with two equal but opposite external forces, one applied by the body and the other by the ground. Three typical instances are shown in Fig. 24*a-c* in which the posture of the various joints is the same in each case and where the joint *A* is vertically beneath joint *H*. In Fig. 24*a* the only force (*W*) exerted by the body on the limb is the weight of the body acting vertically through the centre of rotation of joint *H*; the centre of pressure of the foot lies vertically beneath joint *A*. The knee (*K*) is the only joint about which either the weight of the body or the reaction (W_1) of the ground exerts a turning moment, and flexion of this joint can be prevented by adequate tension in the muscle (M_1) operating about this joint; the tension of the muscle must be such that its moment about *K* is $W.Ka$. The whole limb is operating as a vertical strut.

In Fig. 24*b* the action (*R*) of the body on the limb represents not only a fraction of the body weight acting at *K*, but also an anterior horizontal pull (*P*) by the pelvis against the head of the femur. If the limb is to support the body it must do so as an inclined strut whose axis is *HC*, where *C* is a point on the plantar surface at which the line of action of the force (*R*) exerted by the body meets the ground. Internal stability of the limb depends on the development by the extensor muscle of the knee of a moment equal to $R.Ka_1$, and also on a moment ($R.Ab$) exerted by the extensor muscle (M_0) about the ankle joint (*A*). Provided that the relative tensions of the two muscles are such that the ratio of their moments about their respective joints is always Ka_1/Ab , the

Whole limb will continue to act as an inclined strut whose axis is HC , and whose axial thrust along this line will vary with the absolute value of the tensions developed by the muscles M_1 and M_6 . On the other hand, any change in the relative tensions of the two muscles will cause a movement of the centre of pressure of the foot against the ground and therefore will change the axis of the limb; for example, if the tension of M_6 becomes zero, the centre of pressure moves to a point vertically below the joint A .

In Fig. 24c the force (R) exerted on the limb by the body does not pass through joint H , and therefore exerts a moment about joint H . Stability of the limb depends, as shown in § III, on the muscle M_6 developing a moment about H equal but opposite to $R.Hc$; at the same time M_1 must develop a moment $R.Ka_1$ and muscle M_6 a moment $R.Ab_1$. In short, the internal stability of the limb is secured so long as the tension of the muscles operating about the several joints are related to each other in direct proportion to the distances of the joints from the line of action of the force exerted on the limb by the body—or, in other words, from the line of action of the reaction of the ground against the foot.

In § III the whole musculature of the limb has been regarded as though it were divided into two separate categories, one enabling the limb to exert forces along the mechanical axis of the limb and the other exert horizontal forces at the feet. This classification is, of course, entirely empirical, and it is necessary to consider its relationship to the morphology of the muscles as distributed in life. So long as the limb is acting as a strut as in Fig. 24b, it is legitimate to regard the muscles operating about the joints A and K as axial muscles enabling the limb to exert forces along its mechanical axis only, and as carrying the whole of the body weight which rests on the limb. On the other hand, if the limb is exerting a horizontal force (F)—apart from that due to the action of the limb as a strut—against the ground as in Fig. 24c, it can only do so if the muscle M_6 operating about joint H is active; in this sense, muscle M_6 can be regarded as an extrinsic muscle capable of operating the limb as a lever. It is obvious, however, that the activity of muscle M_6 cannot enable the foot to exert a force (H) against the ground unless muscles M_1 and M_6 co-operate by an adjustment of their tensions such as will compensate the turning moment of the force H about the knee and ankle. In this respect the muscles M_1 and M_6 form an essential part of the mechanism whereby the limb as a whole operates as a lever. The mechanism whereby the limb as a whole is operated as a strut and as a lever is further illustrated by Fig. 24d-f. In Fig. 24d the limb is resisting a reaction (R) from the ground and is stable so long as the muscles M_6 , M_1 and M_6 exert adequate turning moments about their respective joints. The reaction (R) can, however, be resolved into an axial thrust (T) and into a horizontal frictional force (F) acting

at the foot; the limb is stabilized in respect to the axial force (T) by means of the muscles M_1 and M_6 (Fig. 24e) and in respect to the force (F) by the muscles M_6 , M_1 and M_2 (Fig. 24f). Fig. 24d represents the resultant of Figs. 24e and f. Effective control of the limb in its capacities as strut and lever depends, therefore, on the co-operative effort of the whole of its musculature, and this is probably dependent on a widespread pattern of myotactic reflexes.

Just as the force exerted on a limb by the ground can be resolved into components operating the limb as a strut or a lever, so it can be resolved into vertical or horizontal components. As shown in § II, the vertical load (V) on any limb is, within certain limits, under the control of the animal and that the horizontal (H) force acting at the foot is under similar control. For any given position of a joint relative to the centre of pressure of the foot, the bending moment about the joint is $Vx \pm Hy$, where x and y are the co-ordinates of the joint relative to the centre of pressure of the foot. Since both V and H are under control, the strain imposed on any particular joint is also under control, and this power clearly depends on the ability of the animal to adjust the relative and absolute tensions developed by all the muscles of the limb. In order that the limb should function efficiently, the whole of its musculature must act as a single functional unit in which the activity of each individual group of muscles is very closely co-ordinated with that of all the others. Doubtless, to a large extent, co-ordination is dependent on reflex myotactic phenomena, since any tendency for a joint to move under mechanical forces would stretch muscles capable of applying compensating moments about the joint.

The far-reaching co-ordination between the muscles of a pair of ipsilateral limbs can be visualized partially from the example illustrated in Fig. 25. In this particular case the distribution of weight between the front and hind limbs is assumed to be in the proportion of 4 : 5; by control of the protractor or retractor muscles of either limb the animal can vary the amount of friction acting at the foot but (so long as the transverse extrinsic muscles are inactive) an equal amount of friction must act at the other foot if the system is to be in equilibrium. Knowing the position of each limb joint and the magnitudes and directions of both foot reactions, the bending moments in respect to each joint can be calculated. This has been done in Table 1. It may be recalled that if the animal is standing when the longitudinal friction is not equal and opposite for an ipsilateral pair of limbs the resultant couple must be compensated by a definite degree of activity in the adductor or abductor extrinsic muscles. In all cases it is clear that there is a very widespread co-ordination between the whole of the limb musculature when an animal is in a standing posture although the animal can vary or even abolish the

strain falling on any particular muscle. The requisite co-ordination is thus essentially of a dynamic nature and not such that each muscle must contribute a fixed unalterable effort.

The co-ordination between the muscles of each of four limbs can be illustrated by Fig. 26*a*. In this example, each of the four limbs is assumed to be acting as a vertical strut, the posture on the two sides of the body is the same, and the total body weight is distributed equally between the four feet. The posture of the limbs is such that the centre of pressure of each fore limb lies vertically under the centre of rotation of the wrist (*B*), while that of each hind limb lies posteriorly to the ankle (*A*). No strain falls on the muscles operating about the hip joint, but the knee must resist a flexor moment ($W_{BH}Ka$) by activity of its extensor muscles (M_1). Similarly, in the fore limb the humero-scapular joint must resist a flexor moment ($W_{BF}Gb$) and the elbow a

the limits defined in § II) enables a tetrapod increase or decrease the strain falling on the musculature of any of its intrinsic limb joints.

The digitigrade habit

In Fig. 26*b* three limb joints (*K*, *A* and *P*) lie between the hip and the point of application of the reaction of the ground against the foot, and in such cases the animal can change the position of the ankle and knee without altering the mechanical equilibrium of the limb as a whole. By flexing the knee and extending the ankle (Fig. 27), the latter joint can be moved closer to the line of action of the body weight and ground reaction thereby reducing the strain on its extensor muscles to $W_{BH}A_1a_1$, but placing an increased strain ($W_{BH}K_1k_1$) on the extensors of the knee. In plantigrade limbs this principle operates particularly when the forward position of the centre of pressure of the foot is due to the

Table 1

The horizontal columns of the table show the calculated moments of the muscles of the right side of the animal shown in Fig. 25 for different values of friction acting inwards at the feet. Total weight of body 18 lb.; load on right fore limb 4 lb., load on right hind limb 5 lb.

Friction	Muscular moments—in arbitrary units											
	Shoulder		Glenoid		Elbow		Hip		Knee		Heel	
	Prot.	Retr.	Ext.	Flex.	Ext.	Flex.	Prot.	Retr.	Ext.	Flex.	Ext.	Flex.
0	—	4	—	1.2	5.2	—	10	—	11.25	—	0.75	—
0.2	—	3	—	0.54	4.7	—	9	—	10.65	—	1.05	—
0.3	—	2.5	—	0.21	4.45	—	8.5	—	10.35	—	1.20	—
0.4	—	2	0.12	—	4.2	—	8	—	10.05	—	1.35	—
0.6	—	1	0.78	—	3.7	—	7	—	9.45	—	1.65	—
0.8	—	0	1.44	—	3.2	—	6	—	8.85	—	1.95	—
1.0	1	—	2.1	—	2.7	—	5	—	8.25	—	2.25	—
2.0	6	—	5.4	—	0.2	—	0	—	5.25	—	3.75	—
3.0	11	—	8.7	—	—	2.3	—	5	2.25	—	5.25	—
4.0	16	—	11.0	—	—	4.8	—	10	—	0.75	6.75	—

flexor moment ($W_{BF}Ee$). The dynamic co-ordination between the muscles of both limbs can be visualized by imagining the extensor muscles (M_3 and M_4) of the fore limb to reduce their tension to two-thirds of their original value (Fig. 30*b*), without any change occurring in the two right limbs. In order to maintain equilibrium, the left hind limb must exert an increased vertical thrust against the body, and it must act through a point (C_1) on the plantar surface such that its moment about G_2 is equal to that of the thrust of the fore limb. This condition is fulfilled by (i) development of suitable tension in the retractor muscles (M_6) of the limb; (ii) an ability of the ankle to resist, by means of its extensor muscles (M_8), a moment ($W_{BH} \cdot C_1A$) and of the joint *P* to resist an extensor moment ($W_{BH} \cdot C_1P$) by its flexor tendons or muscles (M_7); (iii) a reduction of the strain on the extensor muscles (M_1) of the knee to ($W_{BH} \cdot Ka_1$). Alternatively, a variation in the distribution of the body weight between individual limbs (within

limb being in a retracted posture (Fig. 28) either when the animal is walking or standing with a limb retracted. If the foot remained plantigrade the strain on the ankle would increase linearly with the degree of retraction of the limb. In practice, the maximum strain on the ankle joint is determined by the position of the metatarso-digital joint (*P*), for if the limb is retracted far enough to cause the centre of pressure of the foot to pass through the centre of rotation of this joint, the strain on the extensors of the ankle can be relieved by raising the knee and extending the ankle joint.

The application of this principle to all four limbs suggests that the digitigrade habit characteristic of cursorial mammals is to be associated with the normal posture of the feet relative to the points at which the weight of the body is transferred to the hips and shoulder joints. In limbs of this type the metatarso-digital and metacarpo-digital joints lie much farther back relative to hips and shoulders

an in plantigrade forms. As shown in Fig. 28, the flexure of the knee, whilst relieving the strain on the extensors of the ankle, involves a greater strain on the knee joint itself; and similarly, raising the elbow to relieve the wrist places an additional strain on the extensors of the elbow. By extending the knees and elbows and simultaneously protracting the humerus and retracting the femur, the hips and shoulders are raised, thus relieving the strain on the extensors of knees and elbows and (see Fig. 29) yielding the typical digitigrade posture.

The ankle cannot be raised until the centre of pressure has passed to the distal end of the metatarsal bones and the effort required to extend the joint against the weight of the body increases with the length of these bones. In a plantigrade form there must be a correlation between the length of the bones and the strength of the extensor muscles of the ankle. Once the latter joint is raised, however, as in a digitigrade form, the length of the metatarsals can be greatly increased before a limit is reached at which undue effort is required to extend the joint against the weight carried by the foot. Thus in Fig. 29*d* the metatarsals can be four times as long as in Fig. 29*b* before the same effort is required to extend the ankle. It seems likely that the elongated bones of digitigrade mammals with consequent increase in the length of the stride is a natural sequel to the elevated posture of the ankle and wrist joints. Just as longitudinal movements of the centre of gravity of the body tend to displace the centre of pressure of a plantigrade limb between the heel and toes, so lateral movements tend to displace it laterally on the plantar surface. Animals whose bodies are relatively free from lateral rolling movements may be expected to dispense with lateral digits. It would be of interest to consider the evolution of the tetrapod foot from this point of view.

Curvilinear muscles and muscles or ligaments common to more than one joint

Throughout the whole of the previous discussion the action of a muscle between its points of origin and attachment has been assumed to be one of rectilinear tension (see Fig. 30*a*). While this is true for certain muscles of the tetrapod limb, it is by no means true for all; in some cases the muscle changes its direction between its points of origin and attachment and therefore when under tension it exerts a pressure on underlying structures, including the joint about which the muscle operates; not infrequently, a sesamoid bone may be present in the neighbourhood of the joint. None of these considerations affect the general conclusion that the final result of muscular activity is the development of a turning moment at the joint proportional to the distance of the line of action of the muscle from the centre of rotation of the joint.

In Fig. 30*b*, a muscle (M) is attached to a bone (A) at an effective centre of origin (a); the muscle passes

smoothly over the head of the bone to its site of attachment on the bone B at O ; the tension of the muscle is such that the joint is in equilibrium with the external forces F_1 and F_2 which are equal and opposite to each other. In order to preserve equilibrium of bone B , the tension (T_1) of the muscle acting at O must (if the joint be frictionless) be such that the resultant (R_1) of T_1 and F_1 passes through the centre of rotation (p) of the joint, and the force (R_2) must be at right angles to the surface of the joint. The forces exerted by the muscle against the bone A are, however, (i) its tension acting at a and (ii) a pressure exerted by the surface of the muscle against the bone between x and y . If the joint is in equilibrium (and free from friction) this pressure acts through the centre of rotation of the joint and is equal and opposite to the resultant of R_1 and R_2 ; the net effect of the muscle on bone A is the resultant of P and T_1 ; this is equal and opposite to the force T_1 . The system is essentially unchanged if the pressure of the muscle is exerted against both bones with or without the interposition of a sesamoid bone (Fig. 31*b*) whose essential functions are to increase the working distance of the muscle from the centre of rotation of the joint and provide a bearing surface for the main bones forming the joint.

In a large number of instances curvilinear muscles traverse more than one joint, and so long as the external bending forces pass on the same side of these joints they can all be partially or completely stabilized by tension in a single long muscle. A simple analogous system is shown in Fig. 32. Complete stabilization of successive joints by means of one long muscle is possible if the distances of the joints from the line of action of the external bending forces bear to the working distances of the muscle from the joints a ratio which is the same in all cases. For any other condition one or more 'short' muscles (one-joint muscles) must be operative. Examples of muscles organized into 'short' and 'long' elements are frequent in all tetrapod limbs.

The effect of the limb weight on the stability of intrinsic limb joints

As in the case of the whole limb, a complete picture of the muscular co-ordination necessary for the maintenance of intrinsic limb stability involves a consideration of the strains imposed on the joints by the weights of the individual limb segments. The effect of these forces is, however, of the same fundamental nature as that of the weight of the body. For any given posture a force equal to the weight of the whole limb will act at a centre of pressure on the foot and exert a moment about each of the intrinsic limb joints. The total strain imposed by gravity on the musculature of a joint will therefore represent the sum of the moments of the two forces, (i) the total vertical force exerted by the ground against the foot, (ii) the weight of the limb segments lying distally to the joint.

SUMMARY

1. The patterns of muscular co-ordination necessary to maintain the functions of the whole limb as a strut or lever are described. When functioning solely as a strut, the stability of the limb depends on the co-ordination of the muscles acting about each joint situated distally to the hip or shoulder but proximally to the centre of pressure of the foot; when the limb is functioning as a lever the above muscles must also be co-ordinated with those operating about the hip or shoulder.

2. The quantitative muscular effort required for the stabilization of any limb joint depends on the magnitude and direction of the reaction of the ground against the foot and on the distance of the centre of rotation of the joint from the line of action of this force. Since the reaction of the ground against the foot is under the control of the animal, the latter can continue to stand whilst varying the strain falling on any one intrinsic or extrinsic muscle provided it readjusts the activity of all the others not only in the same but also in all the other limbs. Instances are given of the co-ordination of the musculature in the four limbs of an animal standing at rest.

3. The digitigrade habit is associated with a posture of limbs in which the line of action of the body weight passes anteriorly to the distal metacarpal or metatarsal joints.

4. The forces exerted on joints by curvilinear muscles are discussed. In general the centripetal pressure exerted by the muscle is equal and opposite to the resultant longitudinal thrusts exerted by the two main bones composing the joint. Brief reference is made to multi-joint muscles.

5. The stabilization of intrinsic limb joints to the weight of the limb itself is of the same fundamental nature as that to the weight of the body.

V. THE EQUILIBRIUM OF THE VERTEBRAL COLUMN

Before considering the general effect of the weight of the body on the stability of the vertebral column it is necessary to bear in mind that the column represents a highly complicated anatomical system. Each joint is usually of considerable complexity, and the distribution of the vertebral muscles is by no means simple. To some extent the form of the intervertebral articulations show fairly clear and definite relationships to the degree and type of movements which the animal normally exercises about the joint, but, so far as is known, this point has yet to be examined systematically. Further, it is by no means easy to determine with any accuracy the precise distribution and function of the various components of the vertebral muscles. Many of the observations necessary for an adequate functional study have therefore yet to be made, although the illuminating approach to the mechanics of the problem made by D'Arcy Thompson (1942) makes further analysis

highly desirable. In the meantime, the strain imposed by the weight of the body on the muscles and ligaments of the vertebral column can be examined by methods essentially similar to those already applied to the joints of the limb, and the results obtained can be regarded as an indication of the lines which might be followed for future experimental treatment.

At the outset it is useful to note that the external forces operating about each intervertebral joint may produce one or more of six types of distortion in the vertebral column: (i) longitudinal bending in a vertical plane thus tending to arch (flex) or sag (extend) the back, (ii) transverse bending in a horizontal plane, tending to curve the body to the left or right side, (iii) torsion about a longitudinal horizontal axis rotating one vertebra on its neighbour, (iv) vertical shear, (v) transverse shear, and (vi) longitudinal compression or tension of the vertebral axis. Of these six types of distortion the last three are resisted passively by the inherent properties of the bones, intervertebral facets, and similar structures, and the power of the vertebral column to resist such distortion does not change markedly when all muscular activity is eliminated. In the case of bending and torsional stresses, however, only gross distortion is compensated by ligaments or other passive structures; during life effective control is exercised by muscles.

To provide a picture of the forces which must act across an intervertebral joint in order to maintain the equilibrium of the vertebral column at this level, it is necessary to consider the relationship of the joint to all external forces whatever be the nature of the distortion which they tend to produce. For other purposes, however, it is more useful to consider the variation in the magnitude of one particular type of distortion at different joints in the column.

Longitudinal bending

Longitudinal bending in a vertical longitudinal plane passing through the centre of rotation of all the vertebral joints is induced by (a) all vertical forces acting on the column (i.e. weight of the body, vertical thrusts of the limbs, and vertical components of all muscles under tension), (b) all longitudinal horizontal forces acting dorsally or ventrally to the neutral axis of the column. Two simple cases of vertebral equilibrium are illustrated in Fig. 33. In this figure each of the four limbs is assumed to be acting as a vertical strut, and the two sides of the body are assumed to be functionally symmetrical in the sense that the loads of the left fore and left hind feet are equal to those of the right fore and right hind feet respectively. The vertebral column is therefore free from torsional stresses, and the plane of action of all the vertical and muscular forces acting on the body can be regarded as coincident with the vertical median plane of symmetry of the body. So far as a cervical joint (V_1) is concerned,

The conditions of equilibrium are determined by the weight of the head and neck. If the centre of gravity of all the structures lying anteriorly to V_1 be at G_1 and their weight be W_{HN} the bending moment about V_1 is $W_{HN}x_1$. In order to prevent the head and neck sagging downwards the dorsal musculature (M_1) of the neck must develop a tension (T_1) about V_1 such that $T_1x = W_{HN}x_1$; under these conditions the resultant thrust (R_1) of the body against the joint must be equal and opposite to the resultant of T_1 and W_{HN} . The mechanism is essentially that of a crane. As pointed out by D'Arcy Thompson, animals with heavy heads or long necks are able to exercise a high moment by their neck muscles owing to the presence of long thoracic spines for the attachment of the muscles. When the system is in equilibrium, the head and neck are subjected to two equal and opposite couples, one due to their own weight and the upward thrust of the body at V_1 and the other to the tension of the muscles and the corresponding reaction at V_1 . Further, the total reaction (R_1) at the joint has a vertical shearing component (Sh) and a longitudinal compressional component (C_1); these forces must be resisted by the intervertebral facets.

In the case of a lumbar vertebra (V_2) the conditions are essentially similar except that it is necessary to consider the moment due to the forces exerted by the limb against the pelvis. In the case of the animal shown in Fig. 33, the upward moment of the force (P) acting on the pelvis about the joint V_2 is greater than that of the downward force (W_{HQ}) acting through the centre of gravity at G_3 , and consequently the joint must be stabilized by tension (T_2) in the abdominal or psoas muscles (M_2) acting ventrally to the joint

$$T_2x_2 = P(x_1 + x_2) - W_{HQ}x_2.$$

The reaction (R_2) acting at the joint can be determined from the triangle abc , where ab represents the resultant of the forces P and W_{HQ} ; in this particular case the compressional component of R_2 is much greater than its shearing component.

If a limb exerts a horizontal force against a hip joint which lies ventrally to the vertebral axis its effect will be to reduce or increase the moment of the total reaction at this point about the joint V_2 . If the horizontal thrust of the limb against the pelvis is directed anteriorly, the moment of the hip reaction about V_2 will be reduced; if the thrust against the pelvis acts posteriorly the moment of the hip reaction about V_2 is increased. Thus by exerting the retractor muscles of the hind limb an animal can relieve the strain imposed by the weight of the body on its ventral musculature (M_2). As explained in § III, the hind limbs of an animal at rest can only exert a resultant anterior horizontal force against the body, if the fore limbs exert a corresponding posterior thrust; in other words, the tendency of the back to sag downwards under the weight of the body or of a superimposed load can be reduced by bracing the limbs outwards against the ground. This mechanism

is brought into action when a horse or mule is standing with a heavy load on its back. It is illustrated in Fig. 34 (from Rademaker, 1931). Similarly, if, with all feet extended outwards from the centre of the body, an animal maintains (by means of front retractor and hind protractor muscles) a vertical reaction at each of its feet, the strain on the ventral musculature of the body is correspondingly increased. Thus when standing on a smooth surface the extent to which the limbs can be extended depends not on the strength of the limb muscles but on that of those ventral muscles required to maintain the rigidity of the back (see Fig. 35).

Distribution of strain along the vertebral column

A more generalized picture of the longitudinal bending strain imposed by the weight of the body on the muscles of the vertebral column can be obtained from a consideration of the bending moment curve for the whole of the column. Starting with an elongated type such as that shown in Fig. 36, the column can be regarded as a series of rigid vertebral segments loaded midway between each intervertebral hinge in accordance with the figure shown at each arrow. Assuming all the limbs to act as vertical struts and the feet on the two sides of the body to be symmetrically loaded, the load resting on the front and hind feet can be determined. Bending moments taken about each of the fourteen hinges shown in the figure yields the bending moment curve indicated by the dotted line; moments tending to make the dorsal side of the body convex are shown above the base line, and those tending to make it concave are shown below the base-line. It will be noted that the sites of maximum strain on the dorsal muscles lie over the hips and shoulders, while the maximum strain on the ventral muscles lies approximately midway between shoulders and hips.

The whole bending moment curve represents (Fig. 37) the sum of three separate curves: (i) that due to the head and neck ABC , (ii) that due to the tail DEF , and (iii) that due to the region ($DGHIC$) of the body lying between the shoulders and hips $DGHIC$. The form of the whole curve therefore depends on the relative lengths and weights of the head and neck, trunk and tail. The effect of this principle is shown in Fig. 38. The animal in Fig. 38a represents the animal in Fig. 36 after the removal of the three central segments of the body; the head, neck and tail are now sufficiently large to remove all strain from the ventral musculature. In Fig. 38b, however, the tail has been removed and the strain thereby placed on the ventral muscles which, although considerable, is very much less than that in Fig. 36. In every case the site of maximum strain on the ventral muscles (i.e. the point of inflexion of the bending moment curve) is the site at which no shearing forces are present.

In Fig. 38c the distribution of the weight between joints 3 and 6 has been slightly modified from that

shown in Fig. 38*a*. In Fig. 38*c* the bending curve becomes tangential to the base-line, in other words at joint 4 there is no bending moment and no shearing forces, and since no compression forces are acting along the column it is possible to make an imaginary vertical section through this joint without disturbing the equilibrium of the system. This particular condition is essentially that with which the general tetrapod system has been compared by D'Arcy Thompson (1942), and it represents the animal as two balanced cantilevers. It is, however, difficult to avoid the conclusion that such a form is really a very specialized (and possibly quite theoretical) case of a much more generalized proposition. As pointed out by Thompson, it is difficult to see how animals with small heads and long bodies can be regarded as a pair of balanced cantilevers; they can, however, readily be harmonized with the generalized type shown in Fig. 36.

As already mentioned, an animal is able to control the form of its bending moment curve by exercising leverage against the ground with its limbs. The general nature of this control is illustrated in Fig. 39. As explained in § III, an extrinsic muscle operating between the body and a limb exercises on the body a couple which is equal and opposite to that exercised on the limb. Any such couple can be resolved into compression components along the column and a couple acting at right angles to the column. Thus if the limbs are braced outwards by the protractor muscles of the fore limbs and the retractor muscles of the hind limbs, the effect is to apply a pair of couples (C_1, C_2 ; C_3, C_4) as shown in Fig. 39; the bending moment of either of these couples about each vertebral joint is such as to render the back convex and thus relieve the ventral musculature. How far the natural form of the vertebral column is to be correlated with the strains imposed on it by the weight of the body (see D'Arcy Thompson) remains a fascinating subject for study, but it must be borne in mind that the effective loading of the column is definitely under control of the animal by means of its muscles—and that the greatest strains are probably those imposed by the muscles when the animal is in locomotion. It is, however, clear that if an animal is to stand when using its legs as vertical struts there must be a definite correlation between the weight and length of the body between the points of support with (*a*) size of head and tail and with (*b*) the strength of the abdominal and allied musculature.

Lateral bending

Any horizontal force acting on the body will tend to cause lateral bending at a vertebral joint if its line of action does not pass through the centre of rotation of the joint. The whole of the external horizontal forces acting on the body are due to the activity of the limbs in their capacity as struts or as levers, and so long as the animal is at rest the resultant of all

these forces represents a pair of equal and opposite forces. If the line of action of these two resultant forces lies in the vertical plane occupied by the centres of rotation of the thoracic and lumbar vertebrae no lateral distortion is involved; under all other circumstances bending will occur to one side or the other unless restraint is imposed by the lateral musculature of the column. A simple instance of equilibrium in respect to lateral bending forces is shown in Fig. 40, where the unequal compression exerted by the limbs on the two sides of the body is compensated by tension in the vertebral musculature on the right side of the body. In the case of reptiles and urodeles transverse horizontal forces are probably of greater importance than in the case of mammals. Fig. 41*b* indicates a condition in which the horizontal forces exerted by the limbs on the body will tend to bend the latter into an S-shaped curve unless restrained by appropriate tensions in the lateral musculature.

It should be noted that just as forces exerted by the limbs against the ground exert a strain on the lateral musculature of the back, so intrinsic activity of the back musculature can induce a reaction by the limb against the ground (see p. 93).

Longitudinal torsion

If, in the case of a mammal, the vertical thrust exerted against the body by any one limb is equal to that of its contralateral fellow, the vertebral column will be free from torsion; if the two thrusts are not equal, the consequent torsion must be compensated by muscular or ligamentous torsion. It may be noted that for any given position of the feet and centre of gravity of the body there is only one distribution of the weight between the four limbs which is consistent with an absence of torsional strain (see § II, p. 93). Further, in so far as torsional forces can be initiated by intrinsic action on the part of the vertebral musculature, so an animal can thereby control the amount of weight falling on any one of its feet. It seems likely, however, that torsional effects are most obvious when an animal is in rapid motion, and are largely compensated by the action of ligaments rather than of muscles.

SUMMARY

1. The nature of the strains imposed on the vertebral column by the weight of the body and by the forces exerted by the ground against the feet of a tetrapod are discussed.
2. The mechanical picture presented by a tetrapod is essentially that of a flexible overhung beam supported by four elastic legs; only under very special circumstances can the body be compared to two balanced cantilevers.
3. By means of the muscles of its limbs an animal can increase or decrease the strain falling on its vertebral musculature or vice versa.

Fig. 17. Diagram of an inclined limb stabilized against the turning moment of the weight of the body (W_4x) by a thrust (H_4) exerted by the pelvis against the head of the femur. The axial thrust ($W_4 \sec \alpha$) of the extensor muscles of the limb is equal and opposite to the resultant of the horizontal thrust (H_4) of the pelvis and the weight of the body (W_4) resting on the head of the femur. The horizontal component (friction) of the reaction of the ground against the foot is numerically equal to the horizontal thrust exerted by the pelvis. Fig. a shows the least value of this horizontal thrust and fig. b shows the maximum value: between these two values the limb can function as an inclined longitudinal strut. p = length of the plantar surface.

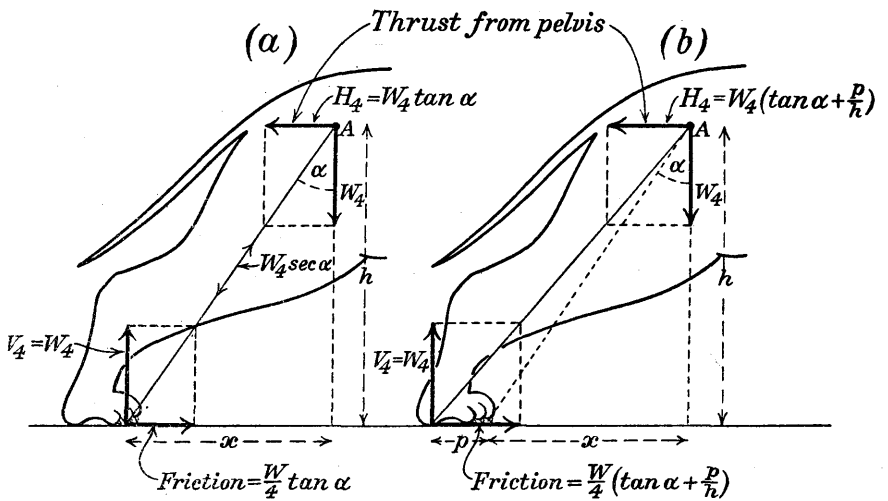
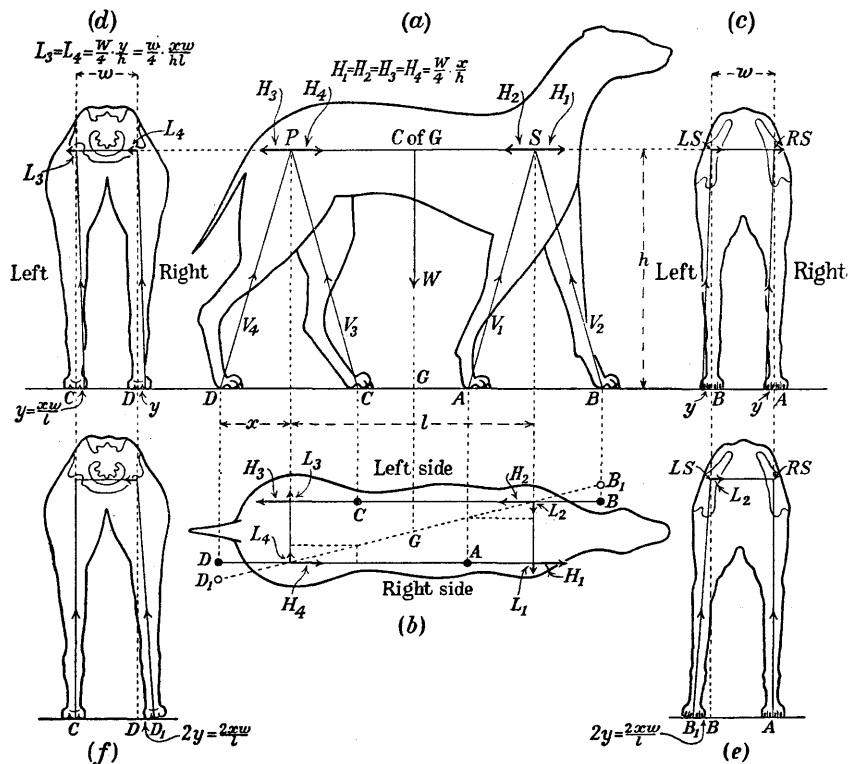

Fig. 20. Diagram illustrating the interdependence of longitudinal and horizontal forces applied to the body by limbs acting as struts. The general conditions are the same as in Fig. 18, except that the two right limbs are retracted and the two left limbs are protracted; all limbs are equally loaded. Each limb applies to the body a horizontal force $H = \frac{W}{4} \tan \alpha = \frac{Wx}{4h}$. The resultant of these horizontal forces is a couple $\frac{1}{2}Ww \tan \alpha$, tending to make the body yaw to the left (fig. b). Equilibrium can be maintained if each limb exerts against the body a transverse horizontal force (L) and these forces act to the right in the case of the front feet and to the left at the hind feet; for equilibrium $L_1 = \frac{Wxw}{4hl}$, where l is the distance between hips and shoulders and w that between the two hips or two shoulders. These transverse forces will be provided if by appropriate internal action (see § IV, p. 102) the centres of pressure of the front feet are moved to the left (fig. c) and those of the hind feet (fig. d) to the right; the animal can stand with the morphological axes of its limbs vertical provided that the centres of pressure can be displaced from the vertical by a distance $y = \frac{xw}{l}$ (see fig. d), where x is the longitudinal displacement of the limb. Alternatively (figs. e, f) equilibrium can be maintained by lateral displacement of the whole left fore limb to the left for a distance $2y$ and of the right hind limb to the right for an equal distance.



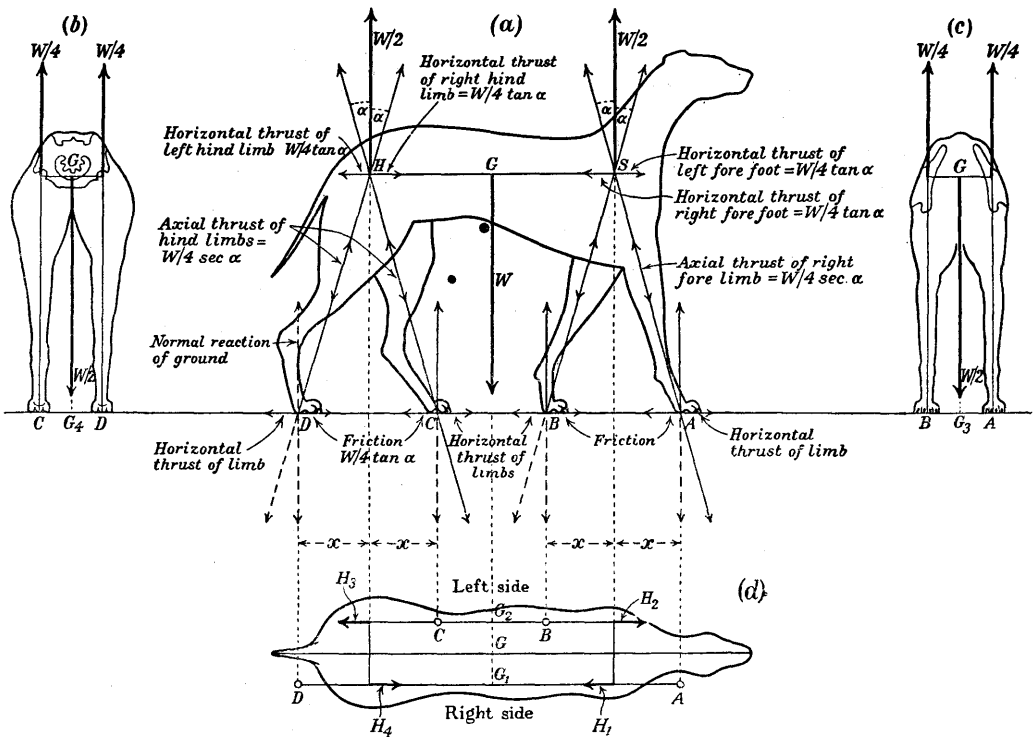

Fig. 18. Diagram illustrating a simple case in which all four limbs are functioning as struts. The two right limbs are inclined outwards and the two left limbs inclined inwards—the degree of displacement (x) from the vertical being the same in all cases. The centre of gravity (G) is equidistant from shoulders (S) and hips (H), and as one limb is assumed to be carrying one-quarter of the total body weight, all the limbs must carry the same load; the vertebral column is free from longitudinal torsion (figs. *b*, *c*). To the head of any one limb the resultant horizontal thrust applied by the body through the vertebral column is equal but opposite to the horizontal component of the axial thrust exerted on the body by the extensor muscles of the limb itself. The body is, however, exposed to equal and opposite horizontal couples operating at the hips and shoulders (fig. *d*); the right side of the body is compressed, and the left side is under tension. These forces are resisted by the vertebral musculature. G =centre of gravity of the body; G_1 =common centre of pressure of the two right feet; G_2 =common centre of pressure of the two left feet. G_3 =common centre of pressure of the two front feet; G_4 =common centre of pressure of the two hind feet.

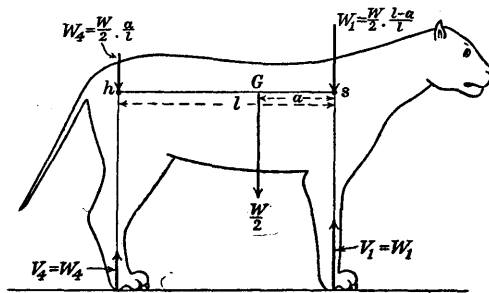

Fig. 16. Diagram of the right side of an animal, all four of whose limbs are acting as vertical struts. The centre of pressure of each limb lies vertically under the centre of rotation of the joint by which the limb is articulated to the body. If the loading of the limbs is symmetrical on the two sides of the body, and the centre of gravity is at G , the load carried by each front and each hind limb is as shown in the figure. For a diagram involving the weights of the limbs themselves see Fig. 24*b*. h =centre of rotation of the head of the femur; s =centre of origin of serratus muscle; V_1 and V_4 =reaction of ground against front and hind feet respectively.

Fig. 19. Diagram illustrating limbs acting as transverse struts. The axes (at and bs) of both limbs are equally inclined (α) to the vertical and both limbs are assumed to be equally loaded (W). As struts, they exert against the glenoid inwardly directed horizontal forces $W \tan \alpha$. So long as the lines of action of the forces (R, R) operating at the feet pass through the centre of rotation of the glenoids and meet at a point (x) vertically above the centre of gravity (G), the limbs can function as struts.

As shown in the figure, the total weight of the body ($2W$) is transferred to the scapulae by the serratus muscles, and the force exerted on the limb at each glenoid represents the resultant of the serratus tension (S) and the force (T) exerted by the ventral elements of the girdle. For the sake of simplicity both these forces are shown as acting through the glenoid; the horizontal and vertical components of S are H and W respectively; the horizontal thrust of the clavico-coracoid is $T [T + H = W \tan \alpha]$. If the line of action of the serratus tension does not pass through the glenoid, other external forces—active or passive—must act on the girdle in order to prevent the latter rotating inwards or outwards about the head of the humerus.

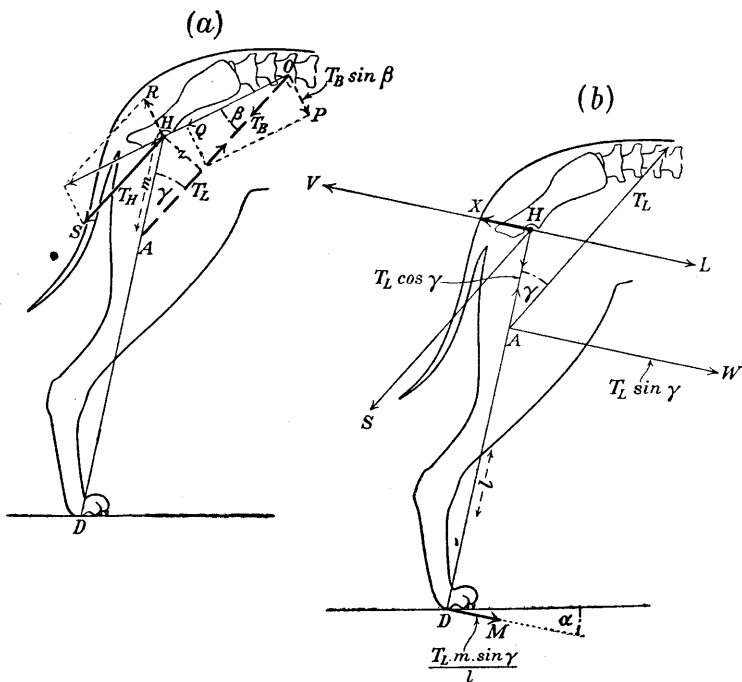
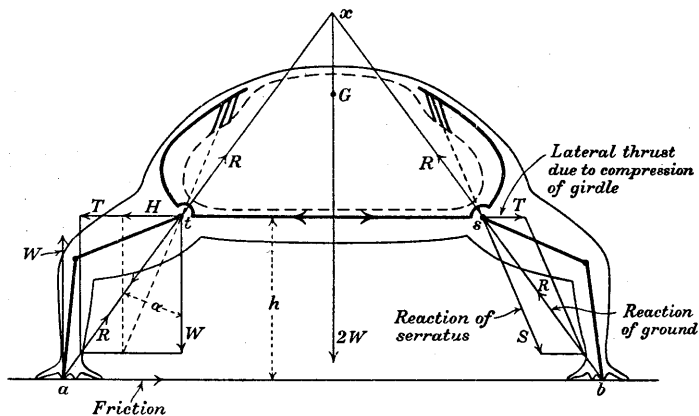

Fig. 21. Diagram illustrating the operation of a limb as a lever when acted on by an extrinsic muscle originating on the body at O (fig. a) and attached to the limb at A . The tension (T_B) of the muscle acting on the body at O can be resolved into forces OQ and OP along and at right angles to the line joining O to the centre of rotation of the joint (H); OQ can be replaced at H by HS parallel to the line of action of the muscles tension and by HR normal to HO . The forces OP and HR constitute a couple of moment $(T_B \sin \beta) OH$ acting on the body, while the forces HS and T_L represent an equal but opposite couple $[(T_L \sin \gamma) m]$ operating on the limb $\left[\frac{\sin \gamma}{OH} = \frac{\sin \beta}{m}; T_L = T_B \right]$.

In fig. b the forces HS and T_L (drawn to a larger scale) are resolved into components acting along and normal to the axis (HA) of the limb; the components acting normally to the limb's axis are HV and AW —both of which are drawn to a still larger scale [$HV = AW$]. If neither the body nor foot is free to move, the force AW exerts reactions HL and DM at the hip and foot respectively. The resultant force acting at the hip is $HV - HL = HX$, while the force exerted by the foot against the ground is DM ; $DM = HX = \frac{T_L m \sin \gamma}{l}$, where l is the length of the limb and m is the distance of the point of attachment of the muscle from the hip joint (H).

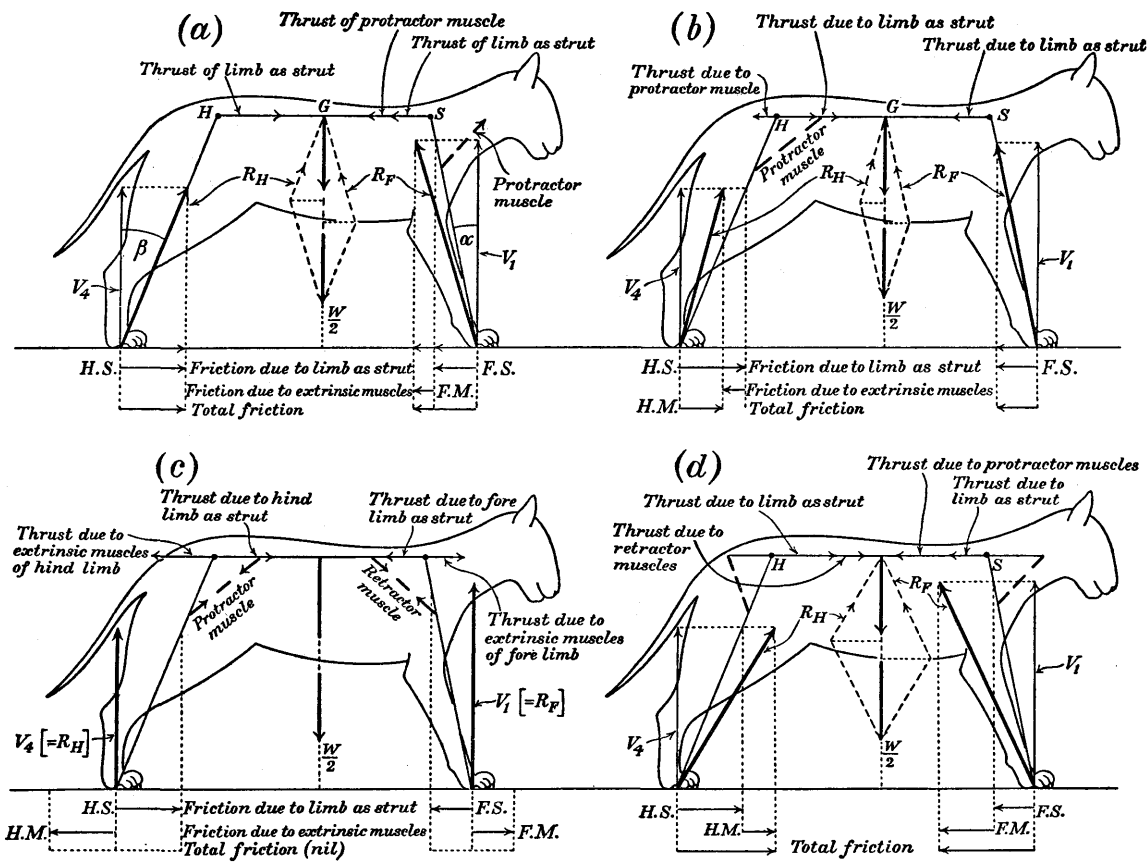

Fig. 22 a-d. Diagrams showing partial range of variation of extrinsic muscular activity within which an animal can remain in equilibrium. In Figs. 9 a-d the two sides of the body are assumed to be symmetrical in posture and in the vertical loading of the limbs; the two sides of the body can therefore be considered independently. The relative inclination and loading of the hind limbs is, however, such that they exert, in their capacities as struts, a greater anterior thrust on the body than is compensated by the fore limbs acting also as struts. In the absence of muscular effort the system is unstable; this effort can be applied in any one of the four ways shown in figs. a-d.

a. The difference between the horizontal thrusts applied to the body and ground by the limbs acting as struts is compensated by a posterior thrust exerted by the protractor muscles of the fore limb. The hind limb continues to act as a strut.

b. The difference between the horizontal thrusts applied to the body is compensated by a posterior force exerted by the protractor muscles of the hind limb. The fore limb acts as a strut.

c. The pull of the hind-limb protractors is equal to the thrust of the limb as a strut; the fore-limb retractors must therefore fully compensate the action of the fore limb as a strut. This is the only arrangement whereby the animal could stand on a perfectly smooth surface.

d. The forward thrust from the hind limb acting as a strut has been increased by the activity of the limb's own retractor muscles. The difference between the total forward thrust from the hind limb and the backward thrust of the fore limb acting as a strut must be compensated by the protractor muscles of the fore limb. This arrangement enables the animal to reduce the strain falling on the axial muscles of the back (see § V).

H=hip; S=centre of attachment of scapula; G=centre of gravity; R_H =reaction of hind limb; R_F =reaction of fore limb; FS=friction at front foot if limb functions solely as a strut. FM=friction at front foot due to action of extrinsic muscles. HS=friction at hind foot if limb functions solely as a strut. HM=friction at hind foot due to action of extrinsic muscles.

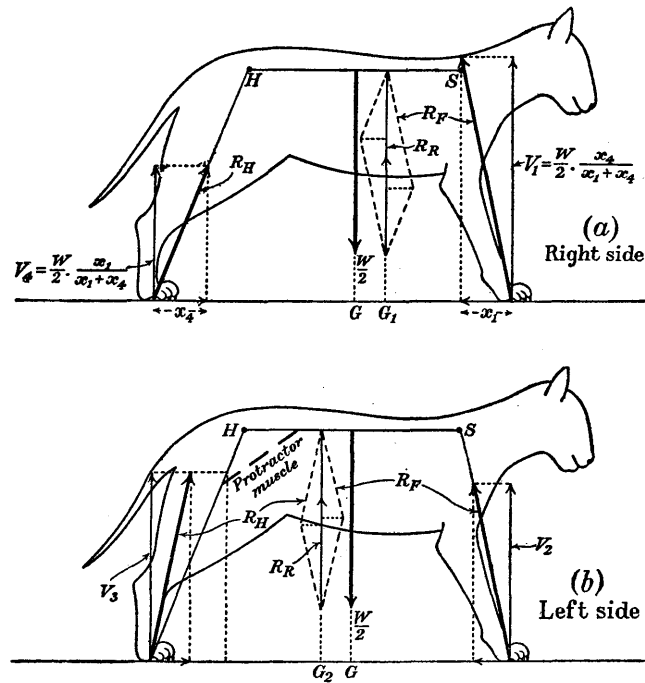

Fig. 23. Diagram showing the effect of variation in limb loading on the range of muscular activity possible for equilibrium. The posture of the animal is the same as in Fig. 22. In fig. *a* the vertical load on the right hind limb has been reduced to $\frac{W}{2} \frac{x_4}{x_1 + x_4}$; if all the extrinsic muscles of this limb have no resultant moment about the hip, the horizontal thrust of the limb against the body is equal but opposite to that of the front limb and consequently both limbs act as struts. The vertical load on the front limb is $\frac{W}{2} \frac{x_1}{x_1 + x_4}$, and the common centre of pressure of the two right feet is at G_1 ; the body is therefore subjected to a turning moment $\frac{W}{2} \frac{ax_4 - bx_1}{x_1 + x_4}$. Equilibrium can exist so long as the resultant of the two reactions of the two left feet yields a vertical force ($\frac{1}{2}W$) acting at G_2 (fig. *b*); $GG_1 = GG_2$. In fig. *b* the whole muscular strain is taken by the protractor muscles of the left hind limb.

Alteration in the distribution of the body weight between the feet does not affect the total amount of effort required from the extrinsic musculature, but it enables an animal to transfer the necessary strain on the extrinsic muscles from one side of the body to the other.

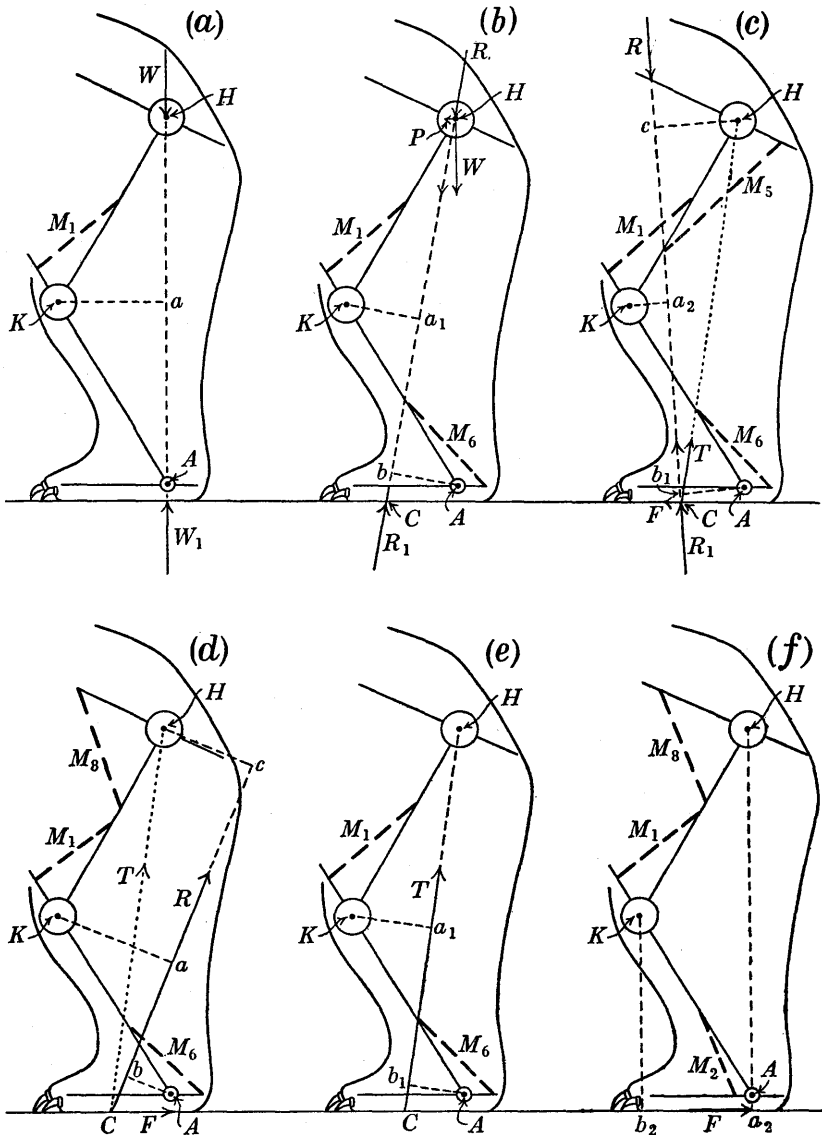

Fig. 24 a-c. Diagrams illustrating the pattern of muscular effort required to sustain the limb against forces applied to it by the body, joint A being vertically beneath joint H . a . The limb is acting as a vertical strut resisting a force (W) due to the weight of the body. Stability depends on adequate tension in the extensor muscles (M_1) of the knee. b . The limb is acting as an inclined strut resisting the weight of the body (W) and an anterior pull (P) exerted by the vertebral column and pelvis. Stability depends on adequate tensions in the extensor muscles (M_1 , M_6) of the knee and ankle. c . The limb is acting as a lever resisting a force R exerted by the body. Stability depends on (i) the level of tension developed by the muscles M_1 , M_5 and M_6 ; (ii) the moments of these muscle tensions about their respective joints must be related in the proportions $Ka_2 : Hc : Ab_1$.

d , e . Diagrams illustrating the pattern of muscular effort required to sustain the limb in its capacity as strut and lever, d . The limb is resisting a reaction (R) from the ground and its joints stabilized by co-ordination of muscles M_8 , M_1 and M_6 . The moments exerted by the three muscles are $R.Hc$, $R.Ka$ and $R.Ab$. The reaction R can be resolved into an axial thrust (T) through the centre of the hip joint (H) and into a horizontal force (F) acting at the foot. e . Pattern of muscular effort (M_1 and M_6) required to sustain the limb as a strut against the axial force T . The moments of the muscles are $T.Ka_1$ and $T.Ab_1$.

f . Pattern of muscular effort (M_8 , M_1 , M_2) required to sustain the limb against the horizontal force F exerted by the ground. The moments of the three muscles M_8 , M_1 , M_2 are $F.Ha_2$, $F.Kb_2$ and $F.Aa_2$. Fig. d represents a combination of the patterns shown in figs. e and f .

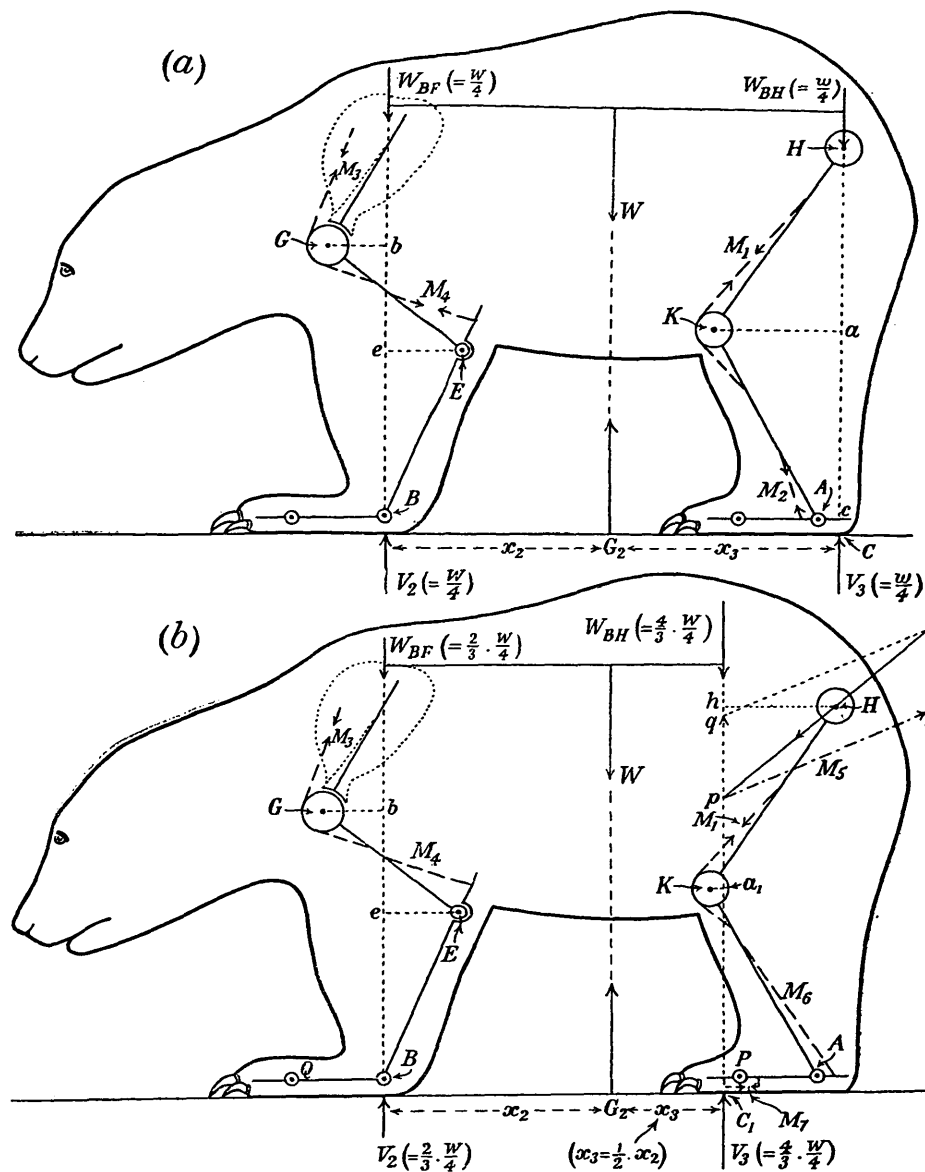

Fig. 26. Diagram illustrating the co-ordination of the muscles of all four limbs. In fig. *a* the limbs are equally loaded and are acting as vertical struts. The body exerts a vertical force ($W_{BF} = \frac{1}{4}W$) against the scapula, the line of action of this force passing through the centre of rotation of joint *B* which lies vertically above the centre of pressure of the foot; both sides of the body are assumed to be symmetrical in posture and muscular effort. The elbow (*E*) is subjected to a flexor moment ($\frac{1}{4}WeE$) which is compensated by tension in the extensor muscle M_4 ; the scapula is subjected to a flexor moment ($\frac{1}{4}WGb$) which is compensated by the extensor muscle M_3 . In the hind limb, the centre of pressure of the foot lies posteriorly to the joint *A* which is subjected to an extensor moment ($\frac{1}{4}WcA$) and compensated in turn by the muscle M_2 ; the knee (*K*) is subjected to a flexor moment $\frac{1}{4}WKa$ and this is compensated by the muscle M_1 .

In fig. *b* the tensions in the extensor muscle (M_4) of the left elbow has been reduced to two-thirds of the value developed in Fig. *2a*; consequently the vertical thrust of the limb has fallen to $\frac{2}{3} \cdot \frac{W}{4}$; the tension of the muscle M_3 must also fall to two-thirds of its original value if the limb is to continue to act as a vertical strut. If no change occurs in the two limbs of the right side of the body, the common centre of pressure (G_2) of the two left limbs must remain unchanged, and if V_2 is reduced to $\frac{2}{3} \cdot \frac{W}{4}$, the centre of pressure of the left hind limb must move forward to C_1 and the load on the limb be increased to $\frac{4}{3} \cdot \frac{W}{4}$. The flexor elements (M_7) of the joint *P* must develop a moment about that joint while the muscle (M_6) must develop a moment about the ankle joint; at the same time the moment about the knee has been reduced to $\frac{4}{3} \cdot \frac{W}{4} Ka_1$, whilst the hip is exposed to a protractor moment ($\frac{1}{4}WHh$) which is compensated by a tension (ps) in the retractor muscle M_5 . Vice versa, if in fig. *a* the retractors of the hind limb were to develop a tension ps as in Fig. *30b* equilibrium will depend on adequate co-ordination in all the other muscles shown in the figures.

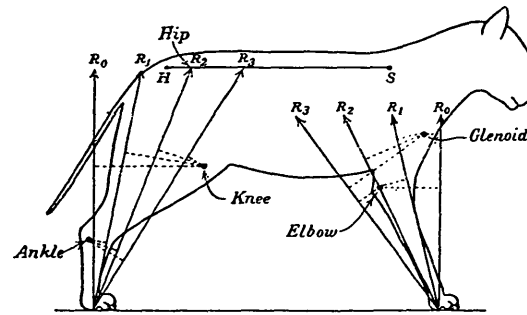

Fig. 25. Diagram illustrating the effect of foot-friction on the strain imposed upon the intrinsic muscles of the limbs. By varying the friction at the feet, the direction of the reaction (R_0, R_1, \dots) at the foot can be brought nearer to or farther away from any individual joint, thus decreasing or increasing the strain on the muscles of the joint. For any given value of foot friction and limb loading there is a definite pattern of strain on each of the limb muscles of both ipsilateral limbs.

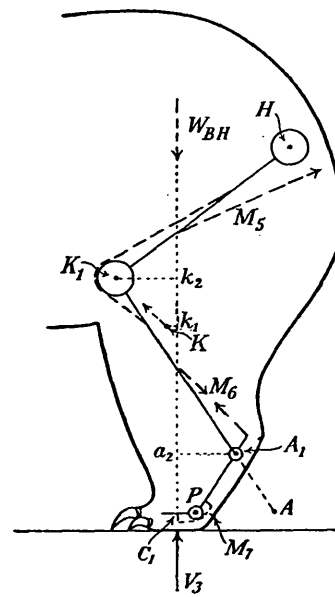

Fig. 27. Redistribution of muscular strain by alteration in the posture of intrinsic limb joints, the external forces acting on the limb being the same as in Fig. *26b*. By raising the knee and ankle joints the strain on the extensors of the latter is reduced. In the plantigrade posture the strain on the heel was proportional to AC_1 , by raising the ankle joint this is reduced to A_1a_1 ; on the other hand, the moment required from the extensor muscles of the knee is increased from Kk_1 to K_1k_2 . A = plantigrade position of ankle joint; A_1 = digitigrade position of ankle joint; K = plantigrade position of knee; K_1 = digitigrade position of knee joint.

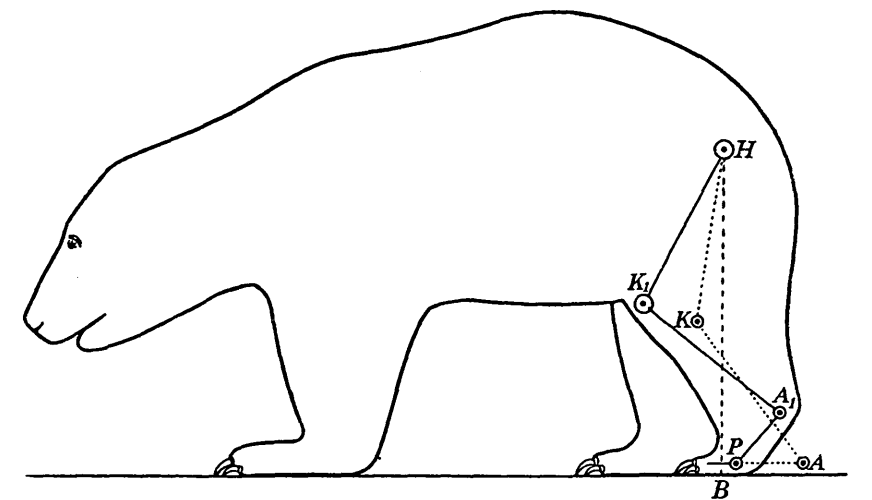

Fig. 28. Typical digitigrade posture of a retracted plantigrade limb, the strain on the ankle being relieved by extra strain taken up by the extensors of the knee. The dotted line (.....) shows the position of the joints if the limb were in the plantigrade posture. The full line shows the position of the joints in the digitigrade posture. The muscular moment about each joint is proportional to the distance of a joint from the vertical line HB . In both postures the limb is acting as a vertical strut.

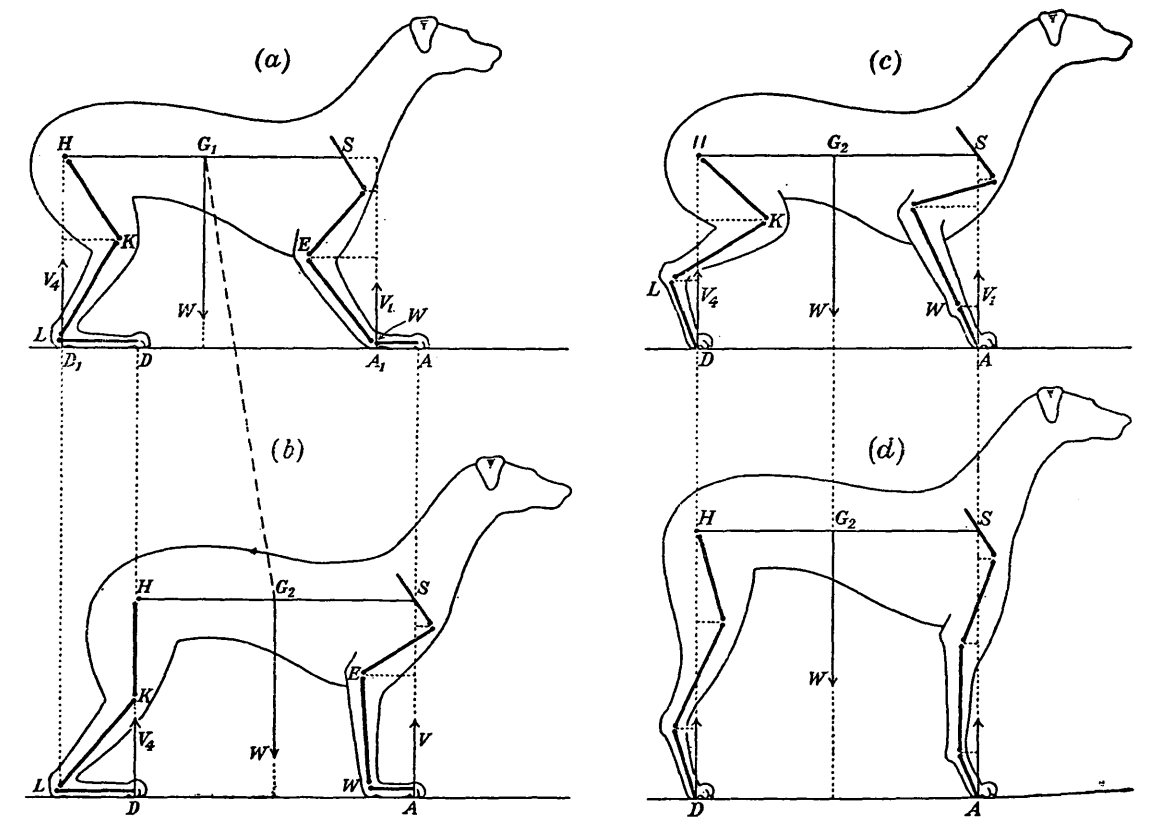

Fig. 29. Relationship between plantigrade and digitigrade habit. *a*. Typical plantigrade habit with plantar surfaces advanced and the centres of pressure at their posterior ends. *b*. By retraction of all the limbs the centres of pressure have moved to the toes. This posture involves a reduction in the strain imposed on the extensors of elbows and knees, but places a considerable strain on the extensors of the wrists and heels. *c*. By raising the knees and elbows the heels and wrists are brought nearer to the line of the reactions of the feet: the strain on the extensors of the wrists and heels is reduced, and that on the elbows and knees increased. *d*. By extending the knees and elbows, hip and shoulder joints the strain on the extensor muscles of these joints is reduced.

Fig. 30. Equilibrium of forces exerted by rectilinear and curvilinear muscles.

a. Diagram illustrating the action of a rectilinear muscle. The two bones *A* and *B* are in equilibrium with two external forces F_1 and F_2 owing to the tension (T_1, T_2) exerted by the muscle M_1 operating between *a* and *O*. The resultant (R) of T_2 and F_2 passes through the centre of rotation (P) of the joint and is counterbalanced by an equal but opposite force provided by the resultant of the forces (T_1 and F_1) operating on bone.

b. The two bones *A* and *B* are in equilibrium with the two external forces F_1 and F_2 by means of the tension exerted by the curvilinear muscle M between its effective point of origin at *a* and its attachment at *O*; the muscle passes smoothly over the distal end of bone *A* and exerts over the surface of contact (*xy*) a pressure P passing through the centre of rotation (P) of the joint. The force exerted by the muscle against bone *A* is the resultant of its tension (ag, rs) and the pressure (rm) exerted through p ; this resultant (rO) is equal and opposite to the force df representing the pull of the muscle against bone *B*. The reaction R_1 between the two bones represents the resultant of F_1 and T_1 and is equal and opposite to the resultant of R_2 and P . The moment of the muscle tension about p does not alter with the posture of the two bones.

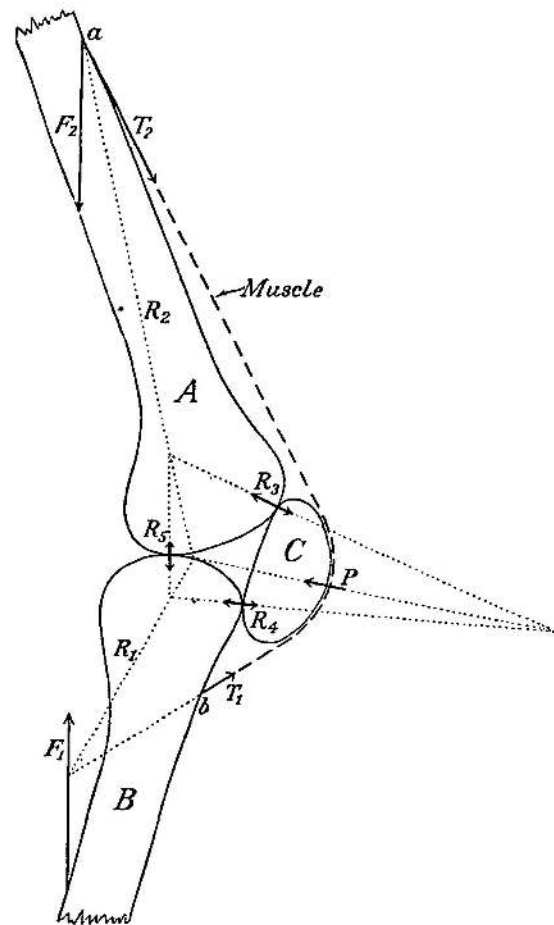
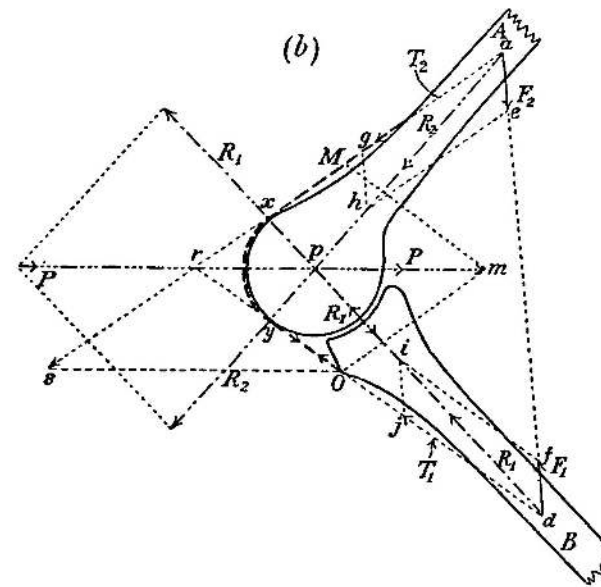
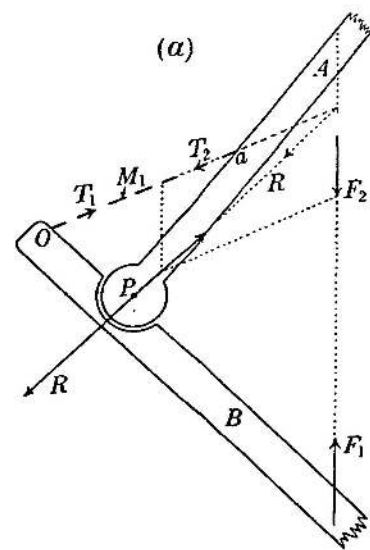

Fig. 31. Equilibrium of a joint involving a sesamoid bone. The forces operating about the joint are the external forces F_1 and F_2 and the tension of the muscle which is attached to the bone *A* at *a* and to the bone *B* at *b*. The system is in equilibrium when the tension of the muscle is sufficient to produce a pressure (P) against the sesamoid bone which is equal and opposite to the resultant of the two reactions R_3 and R_4 , and when the resultant of R_3 and R_4 is equal and opposite to the resultant (R_2) of F_2 and T_2 .

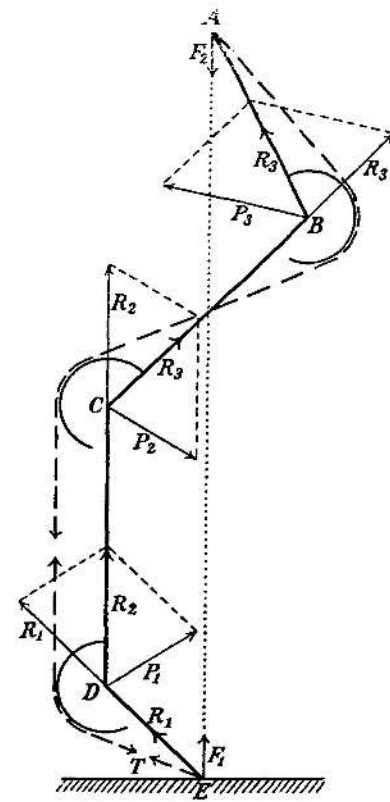

Fig. 32. Diagram illustrating the equilibrium of a chain of four rigid units (*AB, BC, CD* and *DE*) acting as a vertical strut by virtue of a tension (T) in a continuous elastic thread passing round each joint and attached to the chain at *A* and *E*. The point *E* will be stable about *D* when the resultant (R_1) of F_1 and T passes through *D*; the force (R_2) acting along *DC* represents the resultant of R_1 and the pressure (P_1) of the thread against the joint. Similarly at *C* the thrust (R_3) along *CB* is the resultant of R_2 and P_1 , and at *B*, R_4 is the resultant of R_3 and P_2 . The force R_4 is equal and opposite to the resultant of the forces F_2 and T operating at *B*. Note that equilibrium depends on the fact that x_1/r is the same for all joints; x = the distance of a joint from the line of action of F_1 ; and r is the working distance of the thread from the joint.



Fig. 34 (from Rademaker). Photographs showing the ability of a dog to straighten its back, when the latter is under load, owing to leverage exerted by its limbs against the ground.

In fig. 2 the hind limbs are pushing backwards against the fingers of the operator and the fore limbs are pushing forwards. In fig. 3 the hand of the operator on the head of the dog is probably relieving the strain on the protractor muscles of the shoulder.

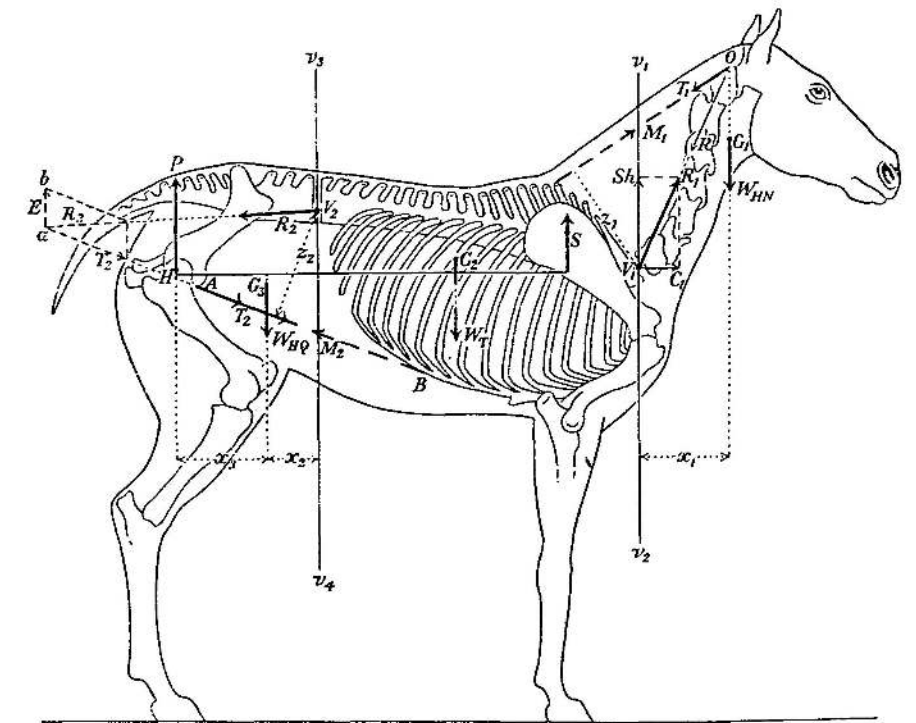

Fig. 33. Diagram showing the general nature of the forces which maintain the equilibrium of vertebral joints. The body is assumed to be divided by two vertical sections v_1v_2 and v_3v_4 passing through the centre of rotation of a cervical vertebra at V_1 and of a lumbar vertebra at V_2 . The centre of gravity of the region lying anteriorly to v_1v_2 is at G_1 , that of the centre section of the body at G_2 , and that of the posterior section lying posteriorly to v_3v_4 is at G_3 . If the weights of the three sections are known and the legs are all acting as vertical struts, the thrust (S) of the fore limbs against the body and that (P) of the hind limbs against the pelvis can both be calculated.

Equilibrium of the head and neck about the joint V_1 is maintained by tension (T_1) in the dorsal musculature (M_1) of the neck, such that the resultant (R) of the pull (T_1) of the muscle and the weight (W_{HN}) of the head and neck passes through V_1 . The joint must receive a thrust (R_1) from the body and be capable of resisting a vertical shearing force Sh and a longitudinal compression C_1 .

Equilibrium of the hindquarters about the joint V_2 must be maintained by a tension (T_2) in the abdominal muscle (M_2) (or equivalent muscle, e.g. psoas) whose moment (T_2x_2) about V_1 is equal and opposite to that of the resultant (E) of the weight (W_{HQ}) acting at G_3 and the thrust (P) of the hind limb acting at H . The body must exert a reaction (R_2) at V_2 .

The thoracic region of the body is in equilibrium with the following forces: (i) the tension of the neck muscles acting anteriorly, (ii) the resultant R acting posteriorly, (iii) the thrust of the fore limb at S , (iv) the weight W_T acting at G_2 , (v) the tension of the muscle M_2 acting posteriorly, and (vi) the reaction at V_2 acting anteriorly.

Fig. 35. Diagram illustrating the effect of friction at the feet on the strain imposed on the muscles of the back. The body is divided by an imaginary vertical section (ss) through a vertebral joint C which, for the sake of convenience, lies vertically over the centre of gravity of the animal. The bending moment about C is

$$(V_3 + V_4)x_4 - Hh - W_Hx_2 = (V_1 + V_2)x_1 - Hh - W_Px_2$$

where $(V_3 + V_4)$ = weight resting on hind feet, x_4 = displacement of the hind feet from ss , H = friction acting at the foot, h = height of C above the ground, W_H = weight of body section lying posteriorly to ss , and x_2 = distance of centre of gravity of posterior section from ss . If $H = \frac{(V_3 + V_4)x_4 - W_Hx_2}{h}$ the resultant (B_2) of the reaction

at the feet (R_2) and the weight (W_H or W_P) passes through C , and the joint is not subjected to any bending moment. If H is less than this value, the resultant (B_2) passes dorsally to the vertebral column which thereby tends to sag at C . If H is greater than $\frac{(V_3 + V_4)x_4 - W_Hx_2}{h}$ the resultant (B_2) passes ventrally to C and the column tends to arch upwards.

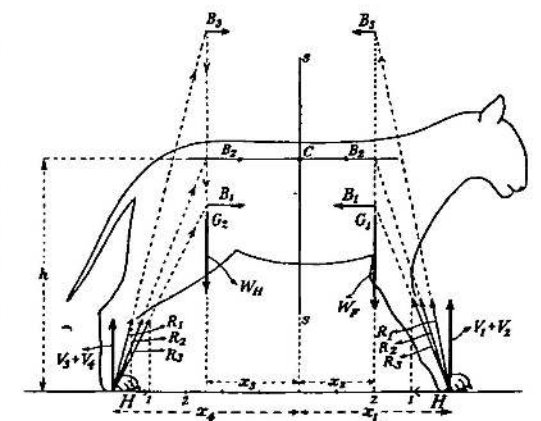

VI. THE LIMBS AS PROPULSIVE UNITS

The mechanical principles whereby the limbs of a tetrapod propel the body forwards relative to the feet are essentially the same as those by which they support it above the ground. In both cases a limb can operate as a strut or as a lever, exerting horizontal forces against the body and against the ground.

The limb as a propulsive strut

If the mechanical axis of a limb is retracted relative to the vertical, the limb can act as a propulsive strut provided that the horizontal component of its axial thrust is greater than the sum of all the posterior forces exerted on the body by the other limbs. On the other hand, a limb whose axis is protracted to the vertical applies, as a strut, a posterior force to the body and therefore acts as a brake. During a complete locomotory cycle the axis of a limb is first protracted and then retracted relative to the vertical and consequently its driving power as a strut is at first negative and later positive; the net propulsive effect depends on the amount of weight resting on the limb during the two phases of the limb's movement, and the locomotory mechanism is essentially the same as that of a punt when propelled by means of a pole.

If the limb girdle be regarded as part of the limb, the latter can act as a propulsive strut so long as the reaction of the ground against the foot passes through the centre of articulation of the body and limb, as in Fig. 42. The propulsive force applied to the body depends on the angle of inclination of the limb and on the axial thrust of the intrinsic limb muscles. As shown in §§ III and IV, a thrust of this type can be maintained so long as the extrinsic muscles remain inactive and the tensions of the intrinsic muscles are such that the moments about their respective joints are to each other in the same proportions as the distances of the joints from the axis of the limb.

It is obvious, however, that a limb cannot change its propulsive action as a strut without upsetting the balance of the vertical forces acting on the body (see p. 91).

The limb as a propulsive lever

As already explained in § III, the horizontal thrust applied to the body by a limb acting as an inclined strut can be increased or decreased by activity of the extrinsic muscles of the limb. Any tension developed by the retractor muscles enables the limb to apply an anteriorly directed force against the body and so enables the limb to act as a propulsive lever. As explained in § III, tension in a retractor muscle exposes the limb and body to equal but opposite couples, and if the foot is prevented from moving, the net effect is to propel the body forward and at the same time to tend to make it pitch about a horizontal transverse axis. The leverage of the limb is illustrated by Fig. 43, in which the axis (*HF*) of

the limb is vertical, and the muscle (*M*) is attached to the pelvis (*P*) at *O*, the pelvis being attached to the vertebral column (*VC*) by an articulation (*S*) and a ligament (*L*). Tension in the muscle (*M*) exposes the limb (*HF*) to a couple (*Aa, Hh*, Fig. 48*b*), and if the foot (*F*) is prevented by moving, the reaction of the ground against the foot is $F_c (= \frac{Tm \sin \gamma}{l})$,

see pp. 113-14). The resultant of the forces *F_c*, *Aa* and *Hh* is a force *Hb* ($=F_c$) acting anteriorly at the head of the limb as in Fig. 48*b* and tending to rotate the limb forwards about the foot. The pelvis (*P*) is exposed to the couple *Od, Hf* (see Fig. 48*c*) and the forcê *Hb*; the resultant of these forces is a force *F_c* acting at the foot, and consequently the pelvis will tend to rotate forwards about its centre of articulation *S* unless restrained by the ligament (*L*) acting posteriorly to *S*. The tension in this element must be such that its moment about *S* is equal but opposite to that of *F_c*. The resultant force exerted by the pelvis is therefore *Sj*, whilst the resultant forces acting on the vertebral column are *Sj, Dk* and *Sl* (Fig. 48*d*), the two latter forces representing the couple exerted by the sacral elements (*L* and *S*). It may be noted that when a limb is functioning as a propulsive lever in this way, the mechanism is essentially that of a canoe being propelled by means of a couple applied to a vertical paddle. The posterior pull exerted on the paddle by the lower arm of the operator represents the tension applied to the limb by a retractor muscle at its effective point of attachment (*A*) to the limb; the forward push against the head of the paddle which is exerted by the upper arm of the operator represents the forward thrust applied to the head of the limb by the pelvis; both the body of the tetrapod and the canoe are exposed to a turning couple.

Co-ordination of limbs as propulsive units

The total propulsive power of a limb is the sum of its action as a strut and as a lever, and the resultant effects of all four limbs represent the net force available for the propulsion of the body.

During every cycle of its movements each limb impresses on the body a relatively complex pattern of vertical and horizontal forces, the nature of which can only be determined by such experiments as those of Manter (1938). Manter's work shows that over the period of one complete cycle of comparatively slow limb movements, the hind limbs of a cat tend to propel the body against the resistance of the fore limbs. As a fore limb is brought into contact with the ground in the protracted position there is a brief period during which the retractor muscles are operative but to an extent insufficient to counteract fully the braking action of the limb as a strut. As the axis of the limb approaches the vertical position, however, the protractor muscles develop tension which increases as the limb is retracted behind the vertical.

Until retraction is nearly complete the braking power of the protractor muscles is greater than the driving power of the limb operating as a strut under the thrust of the intrinsic extensor muscles, and consequently the limb as a whole is acting as a brake. During the final phases of retraction, a converse condition exists for the driving power of the limb as a strut exceeds the braking power of the protractor muscles. The general effect of the extrinsic muscles is therefore to act as brakes on the limb operating as a strut; when the axis of the limb is protracted in front of the vertical the retractor muscles are active, and when the limb is retracted behind the vertical the protractor muscles are in action. Similar conditions exist in the case of the hind limb, but in this case the tension developed by the retractor muscles during the protracted phases of the limb movement may be more than sufficient to compensate the braking power of the limb operating as a strut. Similarly, during the retracted phases of a hind limb the tension of the protractor muscle is relatively small and consequently the limb can operate as a powerful propulsive strut. Over a complete cycle therefore, the fore limbs act as brakes whilst the hind limbs propel the body. This conclusion is illustrated, highly diagrammatically, by Fig. 44.

So far as vertical forces are concerned, Manter's data illustrate several points of general importance. First, even during slow locomotion the total vertical thrust of the limbs is at times substantially greater than the weight of the body and at other times it is less, indicating considerable vertical oscillations of the body relative to the ground. Secondly, the total vertical thrust of the two right limbs may be substantially different from that of the two left limbs, indicating either lateral displacements of the centre of gravity or rotation of the body about its longitudinal axis. On the other hand, the maximal value of the vertical thrust of each limb is approximately in phase with that of the diagonal limb.

Although it is quite clear that the body of a moving animal can never be entirely free from vertical or lateral oscillations, it is nevertheless of interest to consider the general conditions under which such oscillations are reduced to a minimum, thus yielding a type of locomotion which can be regarded as of maximum efficiency. From this point of view the co-ordination of limb effort should be such that the resultant propulsive force acting on the body should always be a horizontal force acting through the centre of gravity of the body, the latter being free from any tendency to rise, fall, pitch, roll or yaw. In order that these conditions should be completely fulfilled in respect to vertical disturbances two features are necessary: (i) not less than three feet must be on the ground at any one instant, and (ii) no foot can be lifted off the ground unless the centre of gravity of the body lies within the triangle of the other three feet.

If all the limbs step with equal frequency and length of stride there are six possible sequences which they can move in relation to each other:

(1)	<i>RF</i>	<i>LF</i>	<i>LH</i>	<i>RH</i>
(2)	<i>RF</i>	<i>LF</i>	<i>RH</i>	<i>LH</i>
(3)	<i>RF</i>	<i>LH</i>	<i>LF</i>	<i>RH</i>
(4)	<i>RF</i>	<i>LH</i>	<i>RH</i>	<i>LF</i>
(5)	<i>RF</i>	<i>RH</i>	<i>LF</i>	<i>LH</i>
(6)	<i>RF</i>	<i>RH</i>	<i>LH</i>	<i>LF</i>

Taking the limiting case in which there are always three, but never four, feet on the ground simultaneously, each foot must be out of contact with the ground for a period of time equal to one-third of that during which it is in contact with the ground and thereby contributing towards the support and propulsion of the body. In other words, as one foot is being placed on the ground the foot which follows it in sequence will be lifted off the ground. For each of the six possible sequences, Fig. 51 shows the positions of the feet relative to the ground and to the centre of gravity of the body during one complete locomotory cycle. It will be noted that full stability is only provided by the diagonal pattern shown in sequence 3, and even then only if the centre of gravity of the body lies at a particular point relative to the shoulders or hips. Phases of mechanical instability inevitably occur in every other sequence. The suggestion thus arises that the diagonal pattern of limb movement, so characteristic of tetrapods, is essentially that which is necessary to maintain stability of the body in respect to vertical forces when the speed of locomotion is slow. This conclusion is confirmed by selecting, at random, a phase from one of the unstable sequences and considering the conditions under which the animal can progress. For example, in Fig. 51 the posture of the limbs is such as to place it in the rotary sequence *RL, LF, LH, RH*; the animal in this initial posture can be regarded as at rest supported by all four legs. Stability can be provided either by the triangle *BCD* or by *ABC*, and consequently either the right fore foot or the right hind foot can be lifted. If the right fore foot is lifted, and subsequent to this each foot in turn is lifted as and when it lies outside a triangle of support, either of the sequences I or II shown in Fig. 52 can occur. If, on the other hand, the animal starts the movement with its right hind foot sequence III (Fig. 52) must take place, it being assumed that a limb cannot be protracted beyond the points shown in the figures. In every case, it will be noted that the sequence of limb movements falls inevitably into the diagonal pattern:

Sequence I,	<i>RF LH LF RH RF LH LF RH</i>
Fig. 51 (I)	
Sequence II,	<i>RF RH RF LH LF RH RF LH</i>
Fig. 51 (II)	
Sequence III,	<i>RH RF LH LF RH RF LH LF</i>
Fig. 51 (III)	

By drawing diagrams, similar to Fig. 52, for any

For of the numerous limb positions displayed in Fig. 51, precisely similar conclusions are reached; in other words, for an animal whose centre of gravity is at G_2 , stable locomotion at a slow speed is only possible if the sequence of limb movements conforms to the diagonal pattern. If diagrams are drawn for an animal whose centre of gravity is at G_1 or G_3 it will be found that stable motion is again only provided by the diagonal sequence, but in this case each limb must be retracted through a greater or lesser angle than is protracted, apart from this the same general conditions hold good. The whole situation can be summarized as follows: Stable locomotion can only occur when (i) a fore foot is placed on the ground at the moment at which the centre of gravity of the body lies on the diagonal joining the contralateral fore foot to the ipsilateral hind foot, (ii) a fore foot is lifted from the ground when the centre of gravity of the body lies posteriorly to the above diagonal, (iii) a hind limb is lifted from the ground when the centre of gravity of the body lies on the diagonal joining the ipsilateral fore foot to the contralateral hind foot, (iv) a hind limb is placed on the ground when the centre of gravity has passed over this diagonal. It must be clearly understood that this picture applies only to an animal moving slowly with three feet (neither more nor less) on the ground at any instant.

The main conclusion to be drawn from the above analysis is that, starting with any arbitrary posture of the limbs, slow but stable progression at uniform speed is only possible if the animal adopts a diagonal sequence of limb movements. To a surprising extent this conclusion can be demonstrated in the case of a spinal newt (Gray & Lissmann, unpublished data). If the nerve cord be severed immediately behind the medulla, a limited number of preparations exhibit clearly defined flexor reflexes in each of the four limbs; if a limb is mechanically retracted, it swings forward in a manner identical with the protractor phase of the limb of an intact walking specimen. If the spinal animal be passively towed along a straight line all the limbs exhibit stepping movements. When the animal is at rest, each limb can be placed in any partial degree of retraction, and if the preparation be then towed by means of a thread attached to its head, the diagonal sequence is rapidly established in all cases, irrespective of the original posture of the limbs (see Fig. 45).

It would be of interest to consider to what extent the distribution of body weight between the limbs forming the triangle of support provides reflex stimulation for the protraction of the fourth limb. At the same time, it is clear that other reflex mechanisms must be operative, particularly those associated with the passive retraction of limbs (Gray & Lissmann, 1940). Whatever be its underlying neuro-muscular mechanism, however, the diagonal pattern of limb movements is essentially an adaptation which permits slow and stable progression to occur.

The relationship of the above arguments to faster types of tetrapod movement will be considered elsewhere. In such cases varying degrees of instability occur in the sense that less than three feet may be on the ground simultaneously; nevertheless, in most cases the diagonal pattern of movement is preserved and is instrumental in reducing the duration of unstable phases to a minimum. Similarly, during very slow movement of some Amphibia and reptiles phases exist when all four feet are on the ground simultaneously. Under these conditions the equilibrium of the body in respect to vertical forces is determined by the same principles as those which exist when the animal is at rest (see § II), and any change in the vertical thrust of one limb must be accompanied by an appropriate readjustment of that of each of the other three (see also legend to Fig. 42).

The equilibrium of forces during movement

So long as the propulsive action of any one limb is equal but opposite to the static braking action of the remaining three limbs the animal remains at rest. If, on the other hand, the propulsive power of one or more limbs exceeds the static braking action of the remainder, the resultant force is free to accelerate the body against dynamic resistances either internal or external to the body. For all moderate speeds, external forces, such as wind resistance, can probably be regarded as small in comparison with the internal resistances which are due to the forces required to stretch the extrinsic muscles of limbs which are acting as brakes. If it is possible to imagine the body of an animal moving forward slowly at constant speed through still air, the propulsive forces and couples applied to the body by the active limbs would be equal but opposite to the restraining forces and couples applied by other limbs acting as brakes. If, on the other hand, the propulsive forces were greater than the restraining forces, the body would be accelerated and the energy of the propulsive limbs used to increase the kinetic energy of the body and not to stretch other extrinsic muscles.

From a functional standpoint it is important to remember that an animal cannot accelerate its body without disturbing the balance of vertical forces acting on it. The significance of this fact is illustrated by Fig. 46, in which the animal is assumed to be standing at rest (Fig. 46*a*) with all its limbs vertical and with the limb loading symmetrical on the two sides of the body. If the retractor muscles of the two hind limbs now develop tension sufficient to exert a total anterior force F against the pelvis the body is thereby exposed to a turning couple C_1 , C_2 (Fig. 46*b*) whose moment is equal to that of the combined tensions of the right and left hind-limb retractor muscles about the hip joints, and also equal to Fh , where h is the height of the limb. This couple induces an upward force D_2 ($= \frac{Fh}{a+b}$) at the

shoulders and a similar downward force D_1 at the hips; there is therefore a transfer of weight from the front to hind limbs, the amount of which varies directly with the height of the body and inversely as the distance between the hips and shoulders. As the animal starts from rest, therefore, additional strain falls on the intrinsic extensor muscles of the hind limbs and less on those of the fore limbs. In an extreme case (when $F = Wb/h$) the whole of the weight rests on the hind limbs and none on the front limbs. This fact is of functional interest for two reasons: (i) The reduction of the weight resting on the front limbs reduces their power of acting as propulsive units since their horizontal thrust cannot exceed a value which depends directly on the weight being carried. A cursorial animal attempting to accelerate rapidly with its front limbs (Fig. 46*d*) runs the danger of these limbs slipping on the ground, whereas an animal accelerating with its hind limbs does not face this danger. (ii) If the turning couple exerted on the body by the retractor muscles of the limb exceeds that which can be compensated by a transfer of weight from front to hind limbs, the axis of the body will rotate upwards about the hips as it moves forwards; the front limbs are thereby lifted off the ground and the animal springs forwards. In other words, by adjusting the posture of the body and the pull of the retractor muscles until the line of action of the reactions from the hind feet passes through or in front of the centre of gravity of the body an animal can jump forwards. The nearer are the hind feet to the centre of gravity the more readily is this condition reached. In forms adapted for jumping (e.g. frogs) the centre of gravity lies well back towards the hip, and the typical 'jumping off' position of a cursorial mammal is characterized by a preliminary backward movement of the centre of gravity of the body towards the hind feet. Conversely, an animal preparing to spring forward without raising its front feet off the ground, starts by moving its centre of gravity well forward from the hips in order to generate a maximum forward drive without wasting energy in lifting the front end of the body off the ground. (iii) In animals whose centres of gravity normally lie well back towards the hips a relatively slight effort on the part of the retractor muscles is sufficient to lift the fore-quarters off the ground, and, if the pull of the retractors is adequate, the body pitches upwards about the hips until its centre of gravity lies over the hind feet; such an animal can remain bipedal as long as the body is held in this position, e.g. a horse when rearing, or *Chlamydosaurus* and similar lizards when moving rapidly.

As already mentioned, an animal which is moving slowly and at uniform speed through still air over a horizontal surface uses the energy of its muscles almost exclusively to overcome resistances internal to the body; the only effective external force acting on the body is gravity, and against this force the

animal does no work. On the other hand, when an animal is moving against an external horizontal strain due to high wind resistance or to an attached load, it is subjected to a backward turning couple which tends to throw the weight of the animal on to the hind limbs, and the conditions are the converse of those in Fig. 11; an equitable distribution of weight is effected by keeping the centre of the body well forwards towards the front feet, thereby enabling the front limbs to function as effective propulsive agents.

Role of the vertebral muscles during locomotion

As explained in § V any vertical force exerted by the extrinsic limb muscles against the body affects the total bending moment about each of the vertebral joints. Thus, if the hind limbs are acting as propulsive levers, the pull of the retractor muscles acting behind the acetabulum tends to arch (flex) the back, particularly in its sacral and lumbar regions, whilst a similar flexing action is exerted on the thoracic region by the protractor muscles of the fore limb if these muscles are operating as brakes. On the other hand, if the retractor muscles of the front limbs are driving against the braking action of the protractors of the hind limbs, the pull of all the muscles is applied between the shoulders and hips and consequently the back tends to sag (extend). In most tetrapods the musculature of the hind limbs is more powerful than that of the fore limbs and consequently the dorsal muscles, particularly in the lumbar region, must respond by powerful contraction when the animal is moving rapidly forwards. Precisely the same principles operate when an animal is pulling a heavy load or walking uphill and therefore 'putting its back into its work'.

In the case of a typical cursorial mammal the propulsive drive is normally controlled by the muscles of the limb, whilst the axial musculature of the back co-operates by providing the body with adequate rigidity. In lower tetrapods, however, the propulsive drive may originate in the vertebral musculature whilst the retractor muscles of the limbs co-operate by giving adequate rigidity to the shoulder and hip joints. This condition (see Fig. 47) is sometimes regarded as the primitive tetrapod condition. In Fig. 47*a* (i) the right fore and left hind limbs are protracted and are in contact with the ground whilst the axis of the body is curved with marked convexity to the right side. If the axial musculature of the right side of the body contracts isotonically (Fig. 47*a* (i) and (ii)), posteriorly directed forces will be exerted by both right fore and left hind feet against the ground provided the retractor muscles of both these limbs hold them isometrically rigid at the shoulder and hip. Alternatively (Fig. 47*b*), a posterior force can be exerted against the ground by isotonic contraction of the retractor muscles of the limbs provided the axial musculature gives sufficient

metric rigidity to the body. In practice the two patterns of movement appear to be superimposed on each other when a newt is moving at relatively high speed (Fig. 47c). In all cases the axial musculature of the back forms an integral part of the locomotory mechanism.

SUMMARY

1. As a propulsive mechanism, the limb of a tetrapod functions as an extensible strut and as a lever. In so far as it acts as a propulsive strut, the limb is extended by its own intrinsic musculature and the mechanism of locomotion is essentially that of a punt when propelled by a pole. In so far as the limb functions as a lever, it is operated by its extrinsic musculature and the mechanism is essentially similar to that of a canoe propelled by a two-handed paddle, the distal end of which remains fixed.

2. In so far as it operates as a strut any limb in a retracted posture exerts a propulsive action; a similar limb in a protracted posture exerts a braking action. In both cases the horizontal force acting on the body depends on the axial thrust of the limb's musculature and on the angle of inclination of the limb. The propulsive or braking action of a limb operating as a strut can be increased or decreased by the operation of the limb as a lever. During each cycle of movement a limb alternately acts as a brake or as a propulsive element; over the whole cycle the fore limbs of a cursorial mammal probably exert a resultant braking action whereas the hind limbs have a resultant propulsive action.

3. The diagonal co-ordination of limb movements seen in nearly all tetrapods enables the limbs to propel the body forwards with a minimum of uncompensated pitching or rolling couples. It is in fact the only pattern of movement which during slow movement enables the body to be in static equilibrium with its own weight at all phases of the movement; the animal can therefore come to rest at any point without falling over.

4. The forces acting on the body and at the feet of a moving animal are discussed, and brief reference made to the relative importance of front and hind limbs as organs of propulsion.

5. The locomotory significance of the axial musculature of the vertebral column is briefly considered.

first and second of these forces are identical and the sum of the two forces is equal and opposite to the reaction of the ground against the foot. In life, such conditions may seldom, if ever, be satisfied, but an approximation is reached in graviportal types similar to the elephant. In the majority of cases, the lines of action of the body and limb weights are not coincident; in Fig. 48b the lines of action in the hind limb, nevertheless, fall within the surface of contact of the foot with the ground, and each can be compensated by an equal and opposite reaction from the ground. The resultant of the two individual ground reactions is a single force (V_4 , Fig. 48) (equal to the sum of the body and limb weights) acting vertically upwards at a common centre of pressure (D) of the foot. The common centre of pressure of the foot lies between the lines of individual action of the body and limb weights at a point (D) about which the moments of the two latter forces are equal and opposite to each other. In other words, the couple exerted by the weight of the limb is equal to that of the weight of the body but is acting in the opposite direction. Any alteration in the loading of the limb will upset this equilibrium. If the weight of the body being supported by the limb be increased, the centre of pressure of the foot will move towards the heel, if the load is decreased it will move towards the toes. If the horizontal displacements of the centre of gravity (g_4) of the right hind limb (Fig. 48c) from a vertical axis through the head of the femur be x and y , the corresponding co-ordinates (x_1 and y_1) of the centre of pressure of the foot are

$$\frac{xL_4}{L_4 + W_4} \text{ and } \frac{yL_4}{L_4 + W_4},$$

where L_4 is the weight of the limb and W_4 the support which the limb is providing for the body.

If the resultant of the body and limb weights falls outside the surface of contact of the foot with the ground the resultant couple exerted on the limb by virtue of its own weight and that of the body must be compensated by methods essentially the same as those which compensate the limb against the weight of the body.

Taking a generalized case, a limb can only be in longitudinal equilibrium when the sum of the turning moments about the foot is zero,

$$M_1 + M_2 + M_3 + M_4 = 0,$$

where M_1 = moment of the weight of the body, M_2 = moment of the weight of the limb, M_3 = moment of the thrust of the vertebral column, M_4 = moment of the extrinsic muscles of the limb. Similar conditions apply to equilibrium in respect to moments acting in a transverse vertical plane.

APPENDIX II

Operation of a limb as a lever

The action of an extrinsic muscle acting about a hip joint can be illustrated quantitatively from Fig. 21. The tension (T_B) exerted by the muscle against the body (Fig. 21a) can be resolved into $OP = T_B \sin \beta$ and into $OQ = T_B \cos \beta$, whilst the latter can be replaced by $RH = T_B \sin \beta$ and by $HS = T_B$. The couple (OP, RH) operating on the body has a moment $T_B \sin \beta OH$, whilst that (HS, T_L) operating on the limb has a moment $T_L z = T_L m \sin \gamma$. Since $OH = \frac{m \sin \gamma}{\sin \beta}$, the moments of

APPENDIX I

Equilibrium of limbs in respect to their own weight

Without introducing any new mechanical principles it is possible to repeat the analysis given in this section, taking into account the weight of the limb itself. Apart from the forces exerted on it by extrinsic muscles there are three forces acting on each limb: (i) the force exerted by the body against the proximal end of the limb, (ii) its own weight acting at its centre of gravity, (iii) the reaction of the ground against the foot. In the simplest mechanical case (Fig. 48a) the lines of action of the

the couples acting on the body and on the limb are equal but opposite to each other; and both are equal to the moment Tz of the muscle's tension about the centre of rotation of the joints.

The ability of the limb to exert horizontal forces against the body and against the ground are illustrated in Fig. 21*b*. The couple (HS and T_L) exerted by the muscle on the limb can be resolved into compression forces ($T_L \cos \gamma$) acting along the upper part of the limb's axis and into components (HV and AW ; $= T_L \sin \gamma$) acting normally to this axis. The force AW exerts a reaction HL ($= T_L \frac{l-m}{l} \sin \gamma$) at the hip and a reaction

DM ($= T_L \frac{m \sin \gamma}{l}$) against the ground. The resultant force ($HV - HL$) acting at the hip is HX ($= T_L \frac{m \sin \gamma}{l}$).

The horizontal component of HX represents a posterior pull exerted on the body, whilst the vertical component of HX contributes towards the support of the body. If the limb is to be in equilibrium when the muscle is in action, a force equal but opposite to HX must be applied by the body to the head of the femur; alternatively, the muscle enables a limb to compensate a posterior thrust from the body by operating the limb as a lever whose fulcrum is the foot.

It is useful to note that if the leverage of the protractor muscle shown in Fig. 21 is accompanied by a relatively small but definite axial tension from the intrinsic extensor muscles (DP and HY in Fig. 49), the resultant forces exerted against the body (HG) and against the ground (DR) are horizontal. In other words, provided that there is slight but adequate co-ordination between the axial and extrinsic muscles, it is possible to regard the vertical forces exerted by the limb as being under the control of the axial musculature whereas variation in the horizontal forces exerted by the limb is under the control of the extrinsic muscles. It must be remembered, however, that the division of the musculature into intrinsic axial and extrinsic rotary units is a purely functional conception; for its relationship to the morphology of the muscles see p. 103.

The ability of an extrinsic muscle to compensate both body and limb against couples imposed on them by the weight of the body is further illustrated in Fig. 50. If the resultant of the weight of the whole body and the vertical thrusts of the three remaining limbs represents a force VB exerted on the body, the external forces acting on the whole body will be in equilibrium provided that a vertical reaction ($V_4 = V_b$) is acting at the foot. In its capacity as a strut the limb applies a vertical thrust (VH) at the hip together with an anterior horizontal thrust ($H_4 = V_4 \tan \alpha$) against the pelvis and consequently the body is exposed to a forward thrust ($H_4 = V_4 \tan \alpha$) and a couple $V_4 x$. If a protractor muscle develops a tension (T), the moment of the couple (HR , OP , Fig. 50*b*) it exerts on the body is Tz (where z is the working distance of the muscle from the joint). Equilibrium between the muscle and the weight of the body will exist when $V_4 x = Tz$. The posterior horizontal force exerted (owing to the muscle) by

the body against the head of the limb is Tz/h , if $T = V_4 x/z$, the posterior thrust of the body against the hip is $V_4 (x/h) = V_4 \tan \alpha$. In other words, the posterior thrust exerted by the muscle on the body is equal to the anterior horizontal thrust exerted by the limb in its capacity as a strut supporting the weight of the body.

Just as the couple provided by an extrinsic muscle can compensate a vertical couple applied to the limb by the weight of the body, so also it can compensate a horizontal couple due to a thrust, or pull, exerted on the limb by the vertebral column.

APPENDIX III

Coordination of limbs acting as struts and levers

The general picture of limb co-ordination can be illustrated quantitatively as follows. In order that the animal in Fig. 22 (whose limbs are symmetrically loaded on the two sides of the body) should not pitch about the front feet

$$V_1 = \frac{W}{2} \frac{x_4 + b}{a + b + x_1 + x_4}, \quad V_4 = \frac{W}{2} \frac{x_1 + a}{a + b + x_1 + x_4}.$$

The two right limbs both acting as struts each exert horizontal thrusts (H_1 , H_4) against the ground

$$H_1 = \frac{W}{z} \left(\frac{x_4 + b}{a + b + x_1 + x_4} \right) \frac{x_1}{h} \left[\frac{x_1}{h} = \tan \alpha \right],$$

$$H_4 = \frac{W}{z} \left(\frac{x_1 + a}{a + b + x_1 + x_4} \right) \frac{x_4}{h} \left[\frac{x_4}{h} = \tan \beta \right].$$

The difference between H_1 and H_4 ($= \frac{W}{z} \frac{(ax_4 - bx_1)h}{a + b + x_1 + x_4}$) must be made good by protractor muscular activity as in Figs. 22*a* and *b*, and the total moments exerted by these muscles must be $\frac{W}{z} \left(\frac{ax_4 - bx_1}{a + b + x_1 + x_4} \right)$.

If the vertical thrust (V_4) of the right hind limb is now reduced to $\frac{W}{2} \frac{x_1}{x_1 + x_4}$ (Fig. 23*a*), that of the right fore (V_1) limb becomes $\frac{W}{2} \frac{x_4}{x_1 + x_4}$. Both these limbs can now support the right side of the body as struts since

$$H_1 = \frac{W}{z} \frac{x_4}{x_1 + x_4} \tan \alpha,$$

$$H_4 = \frac{W}{z} \frac{x_1}{x_1 + x_4} \tan \beta,$$

$$H_1 = \frac{W}{z} \frac{x_4}{x_1 + x_4} \frac{x_1}{h} = H_4.$$

On the other hand, the body is exposed on its right side to a pitching moment (M) about the front feet:

$$M = \frac{W}{z} (a + x_1) - V_4 (a + b + x_1 + x_4)$$

$$= \frac{W}{z} \left[\frac{ax_4 - bx_1}{x_1 + x_4} \right].$$

In other words, the centre of pressure of the two right feet lies at a point (G_1) on the ground anteriorly to G

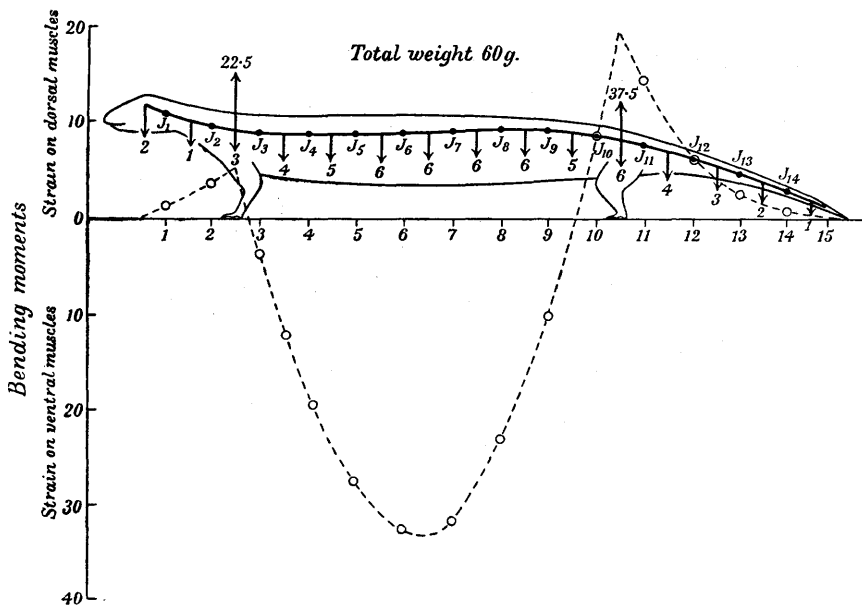

Fig. 36. Diagram illustrating the bending moment curve of a hypothetical reptilian type. The vertebral column is assumed to consist of fourteen equal segments, the loading of each being shown by the vertical arrows; the inter-segmental joints are shown at J_1 - J_{14} . The limbs are acting as vertical struts. The total weight of the animal is 60 g. of which 22.5 g. must rest on the front feet and 37.5 g. on the hind feet. The bending moment curve is shown by the dotted line, strain on the dorsal musculature being shown above the base line. Note that the greatest strain falls on the ventral musculature between joints 6 and 7; at these joints, however, vertical shearing stresses are at a minimum.

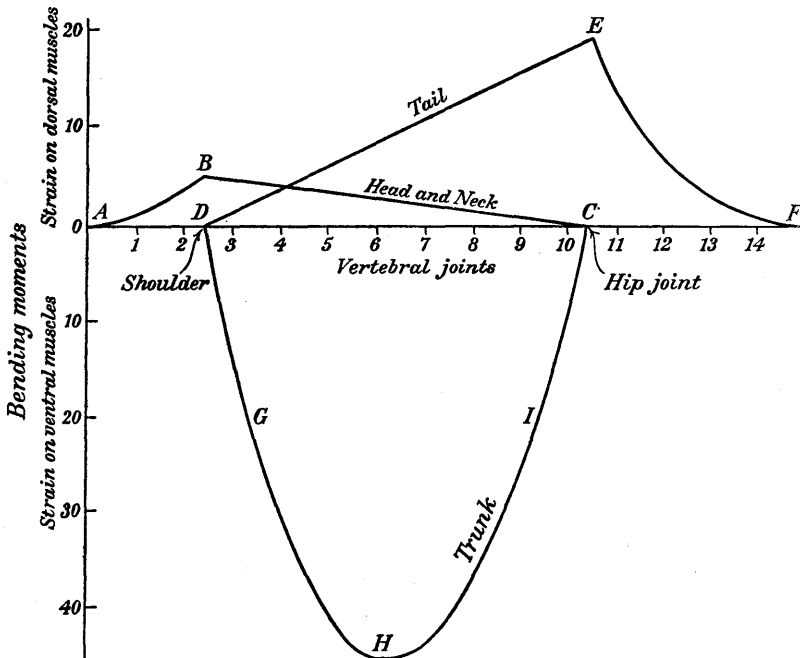

Fig. 37. The complete bending moment curve of Fig. 36 represents the sum of three curves shown in Fig. 37. The strain on the dorsal muscles depends on the size of the head, neck and tail and is greatest over the shoulder and hips. The strain on the ventral muscles is due to the weight of the trunk and is greatest towards the centre; the strain on these muscles increases with the distance from hip or shoulder.

Fig. 38. Diagram illustrating the effect of body form on the strain imposed on the vertebral musculature. Fig. *a* represents the animal in Fig. 36 after omission of the three segments between joints 6 and 9 of Fig. 36; note that there is now no strain on the ventral muscles.

Fig. *b* represents the animal seen in fig. *a* after omission of the tail; note that the ventral muscles of the trunk are now under strain.

Fig. *c* represents a special case in which the form and loading of the body is such that the central section of the bending moment curve is asymptotic to the base-line. This animal can properly be regarded as composed of two balanced cantilevers; joint 4 is free from bending moment and from shearing stress.

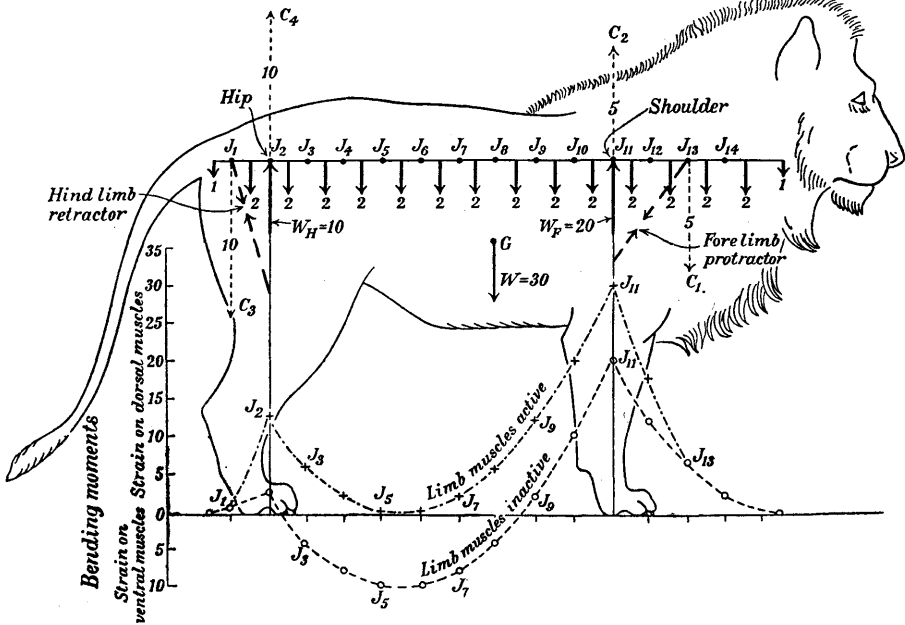
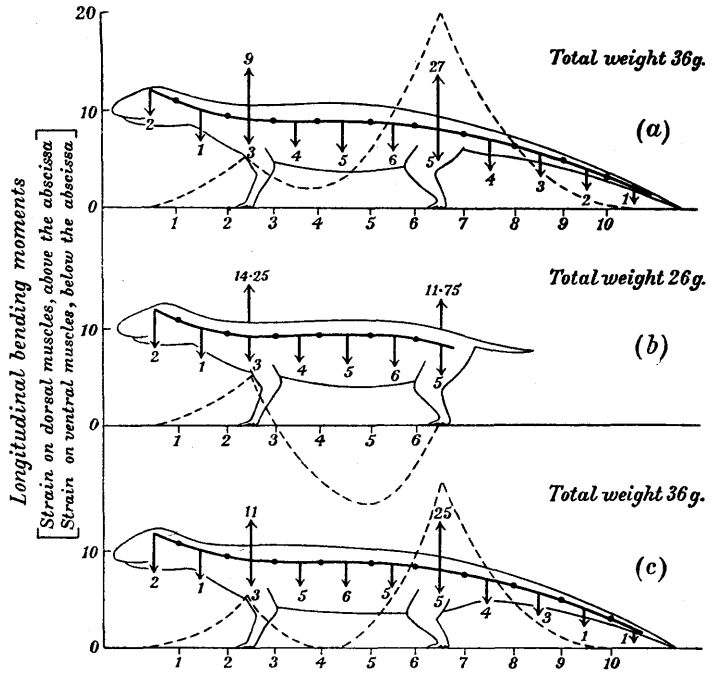

Fig. 39. Diagram illustrating the effect of limb muscles on the form of the bending curve of the back. The vertebral column is shown as fifteen segments loaded in accordance with the small arrows. The total weight (W) of the body is 30 units; the centre of gravity being at G . The load (W_p) on the fore limbs is 20 and that (W_H) on the hind limbs 10. The limbs are vertical and so long as their extrinsic muscles are inactive the curve of the bending moments is shown by the line -----; in the lumbar region the strain is on the ventral musculature. If the fore limb protractor and hind limb retractor muscles apply equal and opposite couples to the vertebral column, and the moment of each of their couples is 10, the curve of bending moments is raised to the level shown by the line - - - - -; the body then represents two balanced cantilevers. If the limb muscles were to develop still greater tension the whole of the back would tend to arch. The curve of the bending moments thus depends on the degree of activity of the extrinsic limb musculature.

Fig. 40. Diagram illustrating the effect of horizontal forces exerted on the body by the limbs (either as struts or levers) on the longitudinal muscles of the back. In the figure the body is subjected to unequal compression on the two sides. Lateral bending of hips and shoulders towards the left side will occur unless opposed by tension in the longitudinal vertebral muscles of the right side, together with adequate compression along the vertebral column. The bending moment about all the vertebral joints of the figure is equal; the figure shows the condition of equilibrium of one joint (J) only.

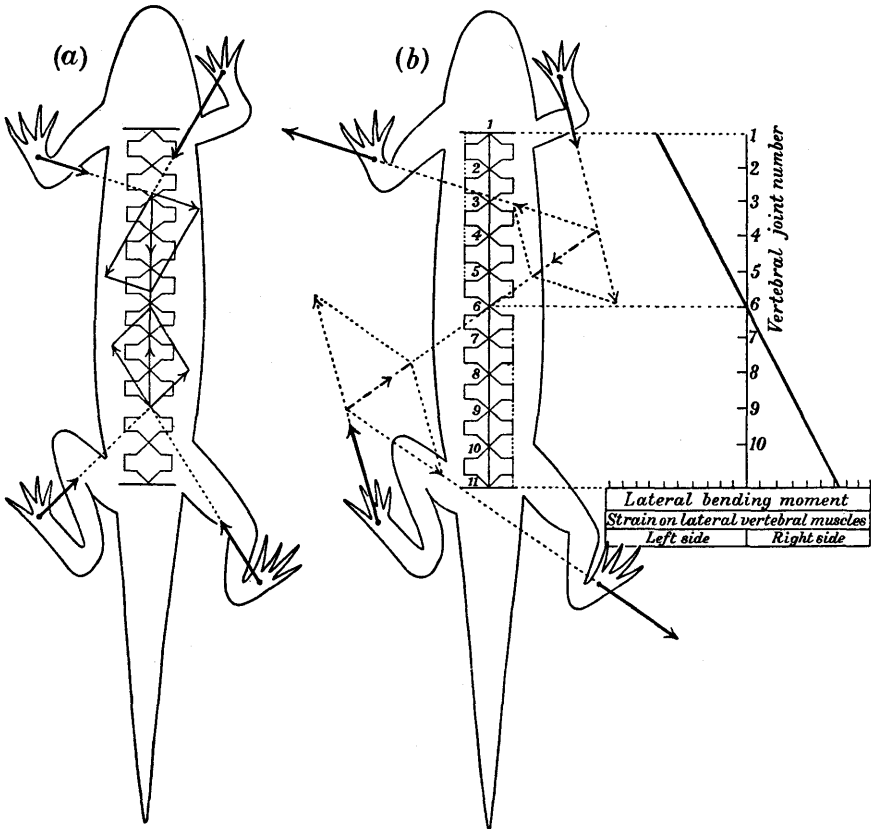
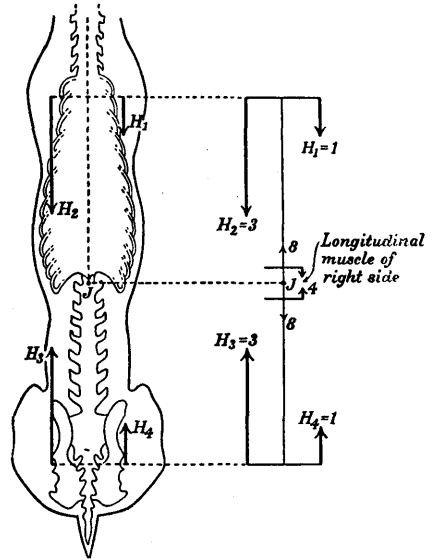
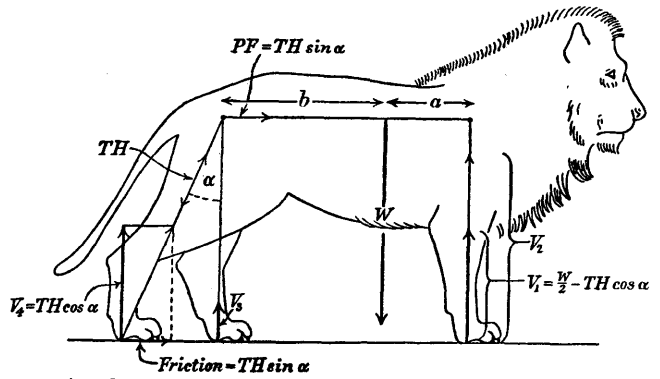

Fig. 41. Figure showing general nature of the effect of both transverse and longitudinal horizontal forces, applied to the body by the limbs, on the lateral musculature of the vertebral column. In fig. *a* the resultant of the horizontal forces exerted by the two front limbs is equal and opposite to that of the hind limbs and both resultants act through the centres of rotation of all the vertebrae. No strain is therefore imposed on the lateral musculature.

In fig. *b* the resultant of the forces from both pairs of limbs passes obliquely across the vertebral column. In the front half of the body the strain is on the muscles of the left side and in the hinder half of the body the strain is on the muscles of the right side. The muscular strain is nil across joint 6, but increases linearly from this point towards the shoulders and hips.

Fig. 42. Diagram illustrating the right hind limb of an animal functioning as a propulsive strut whilst the other three limbs function as vertical struts. If the body moves forward without rolling about its longitudinal axis or pitching about a horizontal transverse axis the vertical axial thrusts of each of the other three limbs must have a definite value as shown in the figure in terms of the weight (W) of the body and axial thrust (TH) of the right hind limb. If TH = the axial thrust of the right hind limb the propulsive thrust of the limb $PF = TH \sin \alpha$, the vertical thrust (V_4) of the right hind foot is $TH \cos \alpha$, that (V_1) of the right fore foot must be $\frac{W}{2} - TH \cos \alpha$,



that (V_2) of the left fore foot is $\frac{W}{2} \left(\frac{b-a}{a+b} \right) + TH \cos \alpha \left(\frac{a+b+h \tan \alpha}{a+b} \right)$ and that (V_3) of the left hind foot must be $\frac{W}{2} \left(\frac{2a}{b+a} \right) - TH \cos \alpha \left(\frac{a+b+h \tan \alpha}{a+b} \right)$; h is the height of the centre of gravity of the body above the ground; a and b are the distances of the shoulder and hip joints from the centre of gravity (see equations vii-ix, p. 92). So long as these conditions are fulfilled the body will not roll or pitch; any change in the axial thrust of the right hind limb must be accompanied by a corresponding change in the axial thrust of the left fore limb. If the latter limb also exerts a horizontal longitudinal thrust equal to that of the right hind limb, the body will not roll, pitch or yaw.

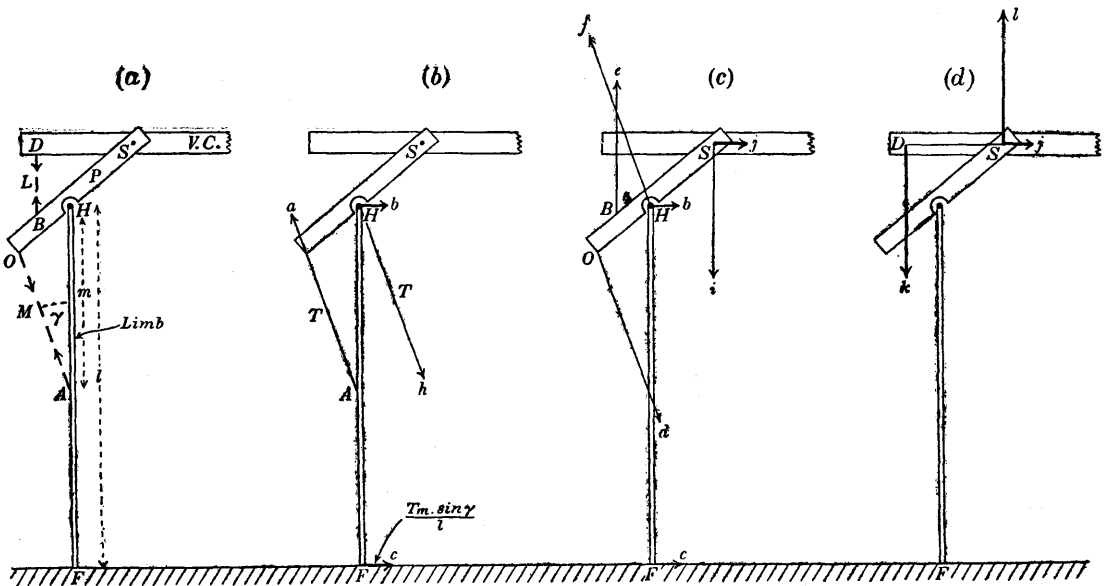

Fig. 43. Diagram illustrating the forces acting on a hind limb, pelvis and vertebral column when the limb is operating as a propulsive vertical lever owing to tension in a retractor muscle.

a. HF = axis of limb, H = centre of rotation of head of femur, F = effective centre of pressure (and centre of rotation) of the foot against the ground, γ = effective angle of insertion of muscle on limb, l = length of limb, m = distance of attachment (A) from head of limb, P = pelvis, L = sacral ligament, S = centre of articulation of pelvis to vertebral column (VC).

b. Forces acting on the limb. A tension (T) in the muscle M exposes the limb to the couple Aa , Hh , and if the foot is held stationary the horizontal reaction of the foot against the ground is $F_c = \frac{Tm \sin \gamma}{l}$. The resultant external force acting on the limb is $Hb \left(= \frac{Tm \sin \gamma}{l} \right)$ acting horizontally forward at the head of the femur.

c. Forces acting on the pelvis. The pelvis is exposed to the force Hb exerted by the limb, and the couple Od , Hf exerted by the muscle; the resultant of these three forces is a force F_c acting at F . This force tends to rotate the pelvis forwards about S unless restrained by tension (Be) in the ligament L ; the moment of Be about S must be equal but opposite to that of F_c . Tension in the ligament L , exposes the pelvis to the couple Be , Si , and the resultant force acting on the pelvis is Sj .

d. Forces acting on the vertebral column. The vertebral column is exposed to a forward thrust Sj , and to the couple Dk , Sl due to the action of the ligament L . This couple is equal to that exerted on the pelvis by the muscle M .

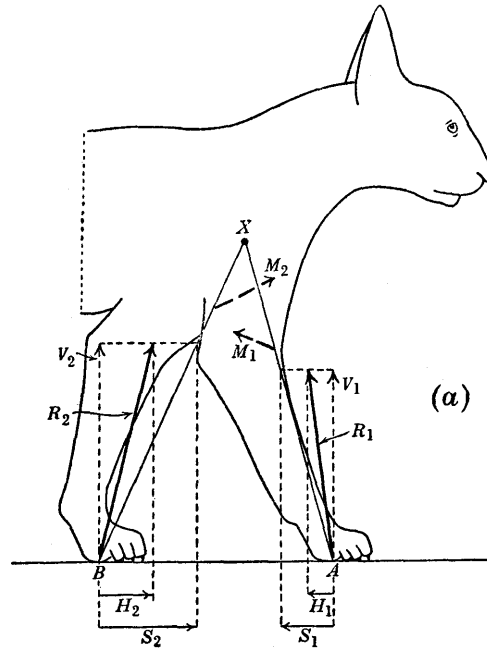

Fig. 44 a. Diagram illustrating the operation of fore limbs as brakes and as propulsive units. The right limb is protracted and as a strut, supporting the weight (V_1) of the body, it would apply a retarding force (S_1) to the shoulder girdle; the action of the retractor muscles (M_1) reduces this force, but the net action of the limb is that of a brake applying a retarding force (H_1) to the body. The left limb is retracted and as a strut, supporting the weight (V_2) of the body it would apply a driving force (S_2) to the body; the action of the protractor muscles (M_2) reduces this force, but the net action of this limb is to effect propulsion. X =glenoid; XA and XB =axes of right and left limbs. R_1 and R_2 =reactions from the ground against the right fore and left fore feet. V_1 and V_2 =vertical components of R_1 and R_2 .

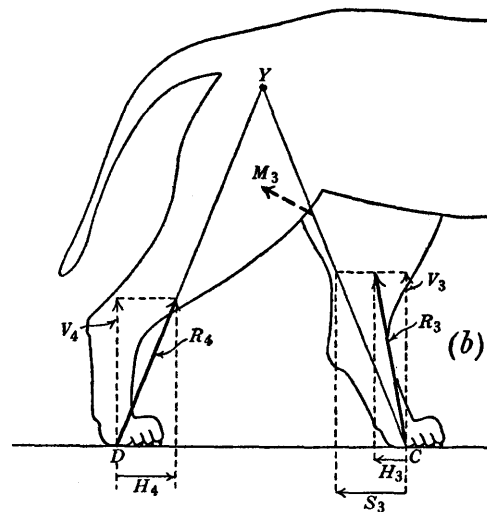

Fig. 44 b. Diagram illustrating the braking and propulsive action of hind limbs. The right hind limb is retracted and is acting solely as a propulsive strut by means of its intrinsic muscles. The left limb is protracted and as a strut it would exert a retarding force (S_3) against the hip; owing to the action of the retractor muscles (M_3) this force is reduced to H_3 . Y =acetabulum; YC , YD =axes of right and left limbs. R_3 , R_4 =reactions from the ground against the left hind and right hind feet. V_3 , V_4 =vertical components of R_3 and R_4 .

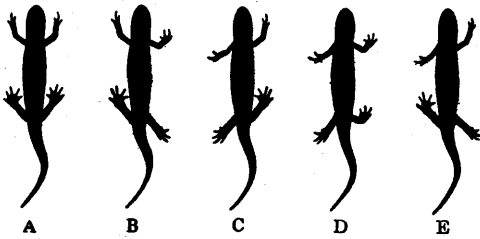

Fig. 45. The table shows the sequence of limb movements observed when a spinal newt (*Triton cristatus*) was towed along a straight path, the initial positions of the limbs (A–E) are shown above. Note that the diagonal pattern is reached in nearly all cases; in some instances, however, the *LF* and *RH* limbs tend to be interchanged in the sequence giving (1.2.4.3). Figures in italics indicate movements showing no diagonal co-ordination. Figures in brackets refer to members of a diagonal pair moving in inverted order.

Initial posture of limbs	Sequence of steps (1=RF; 2=LH; 3=LF; 4=RH)
A	(I) 4.1.2.3.4.1.2.3.4.1.2.3.4 (II) 3.4.1.2.3.4.1.2.3.4.1.2.3 (III) 1.2.3.4.1.2.3.4.1.2.3.4.1 (IV) (4.3)(1.2)(4.3)(1.2)(4.3)(1.2)(4)
B	(I) 3.4.1.2.3.4.1.2.3.4.1.2.3.4 (II) (4.3)1.2.3.4.1.2.3.4.1.2.3.4 (III) 4.3.1.3.4.1.2.3.4.1.2.3.4
C	(I) 4.1.3.2.4.3.1.2.3.4.1.2.3.4 (II) 1.4.1.3.2(4.3)1.2(4.3)1.2(4) (III) (1.2)(4.3)(1.2)(4.3)(1.2)(4.3)(1.2) (IV) 1.4.1.2.3.4.1.2.3.4.1.2.3
D	(V) (4.3).1(4.3)(1.2)(4.3)1.2.3.4.1.2.3.4
E	(I) 3.4.1.2.3.4.1.2.3.4.1.2.3.4

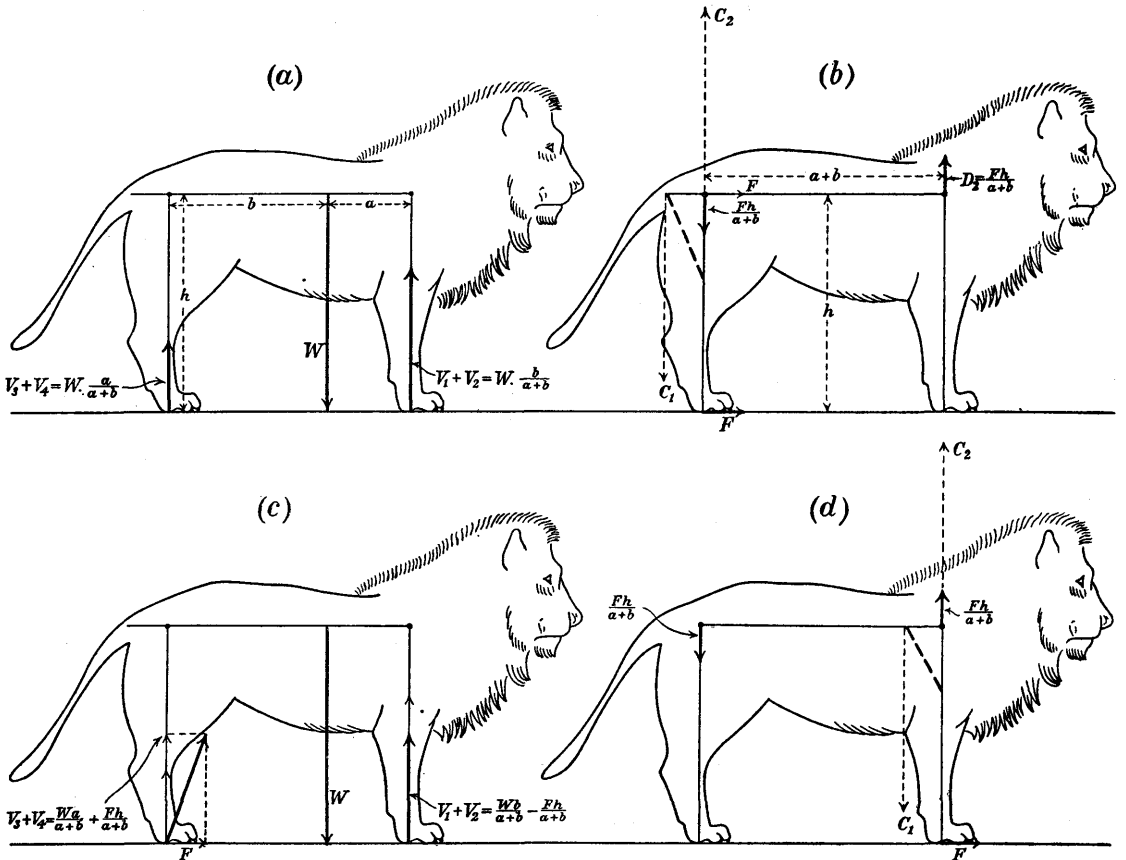

Fig. 46. Diagram illustrating the transfer of weight from the front to hind limbs when a tetrapod accelerates from rest.

a. Distribution of body weight (W) between front limbs ($W \frac{b}{a+b}$) and hind limbs ($W \frac{a}{a+b}$) when the animal is standing at rest with all four limbs vertical; a and b are the distances of the centre of gravity of the body from the shoulders and hips respectively.

b. If the retractor muscles of the hind limbs develop tension, the body is subjected to a couple (C_1C_2) whose moment is Fh where F is the frictional reaction at the hind feet and h is the height of the limb. The couple C_1C_2 causes an upward reaction D_2 at the shoulders ($F \frac{h}{a+b}$) and a resultant downward force at the hips also equal to $F \frac{h}{a+b}$.

c. The combined effect of the weight of the body and the muscular couple acting on the body produces a vertical reaction at the hind foot equal to $W \frac{a}{a+b} + \frac{Fh}{a+b}$, and at the front feet equal to $W \frac{b}{a+b} - \frac{Fh}{a+b}$.

d. Diagram showing that a similar redistribution of weight accompanies an acceleration of the body by the retractor muscles of the front limbs.

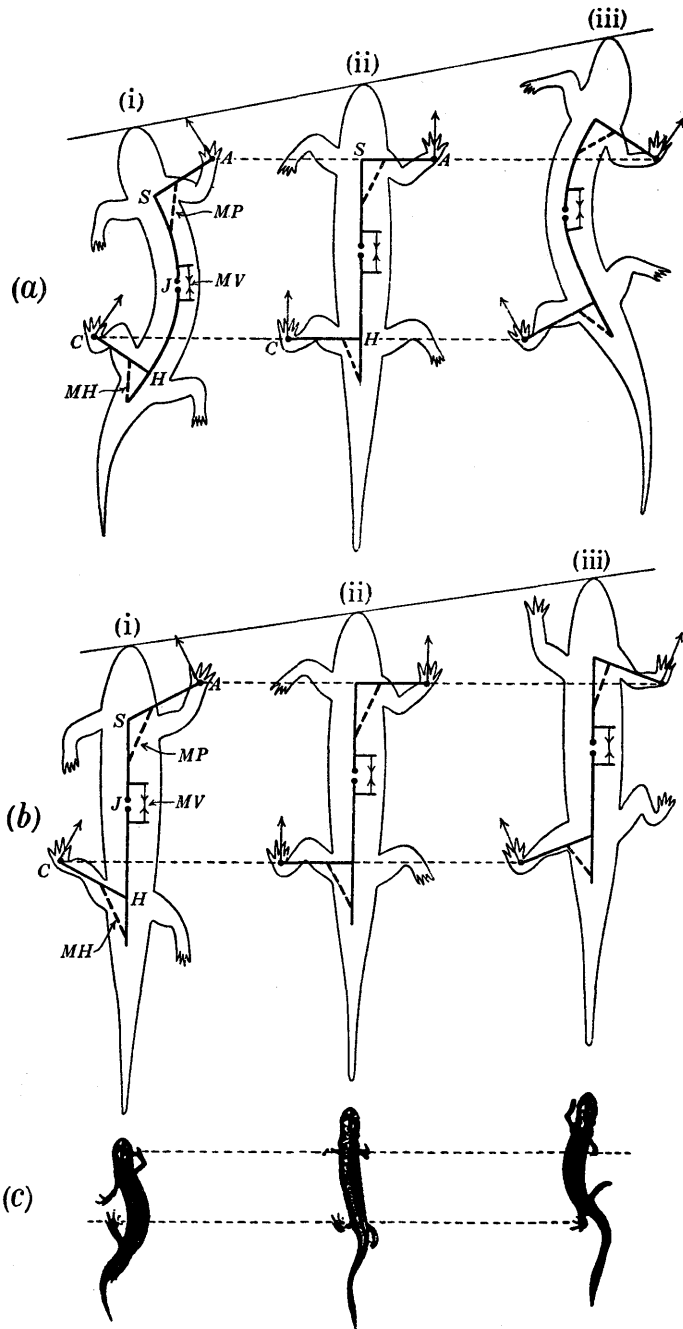

Fig. 47a. Diagram illustrating propulsion of a tetrapod by isotonic contraction of the vertebral muscles, the retractor muscles of the limbs contracting isometrically and locking the shoulder and hip joints. Initially, the body is bent convexly to the right, the right fore and left hind feet (*A*, *C*) are fixed. Progression occurs when the vertebral muscles of the right side contract. The arrows at the feet show the forces acting on the body which are normal to the axis of the limbs; other components of the foot reaction are omitted. *SH*=vertebral column; *J*=vertebral joint; *MV*=vertebral muscles of right side; *MP*=retractor muscles of right fore limb; *MH*=retractor muscles of left hind limb; *AS*=axis of fore limb; *CH*=axis of hind limb.

b. Diagram illustrating propulsion of a tetrapod by isotonic contraction of the retractor muscles of the limbs, the vertebral muscles contracting isometrically and maintaining the rigidity of the body.

Successive photographs of a moving newt.

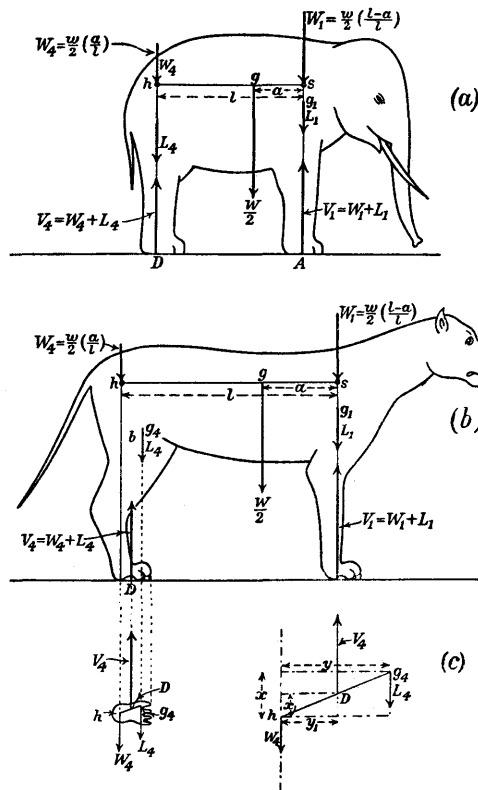

Fig. 48. Diagrams illustrating limbs with vertical axes in equilibrium with their own weight and that of the body; in both cases the body is assumed to be free from longitudinal torsion so that the distribution of the body weight between the front and hind feet is inversely proportional to the distances of the hips and shoulders from the centre of gravity (g). In fig. *a*, the line of action of the body weight acting at the head of each limb and the line of action of the limb's own weight are coincident; the limbs act as vertical struts with the centres of pressure of the feet vertically beneath the shoulders and hips. In fig. *b* the lines of action of the body and limb weight are not coincident in the hind limb; the centre of pressure (D) of the hind foot therefore lies between these two lines, its exact position depending on the relative magnitude of the body and limb weight and on the horizontal co-ordinates of the limb's centre of gravity from the vertical line passing through the hip (fig. *c*).

Fig. 49. Diagram illustrating the mechanism whereby an animal can control the horizontal thrust applied by a limb to the body without altering the distribution of weight between its feet. If a protractor muscle (such as that shown in Fig. 21*b*) develops tension T , and thereby exerts as in Fig. 26 a force HX against the pelvis and a force DM against the ground, and if at the same time the intrinsic muscles of the limb exert an axial tension T_a (HY and DP) then the resultant reaction (HG) of the limb against the body is horizontal, as also is the force (DR) acting at the foot.

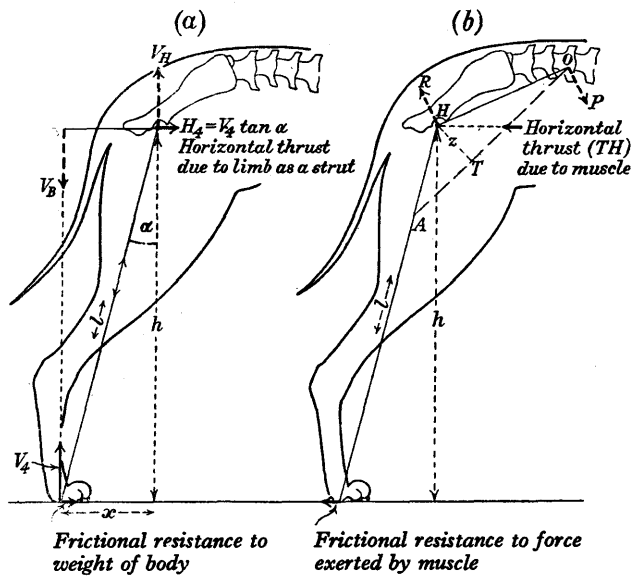
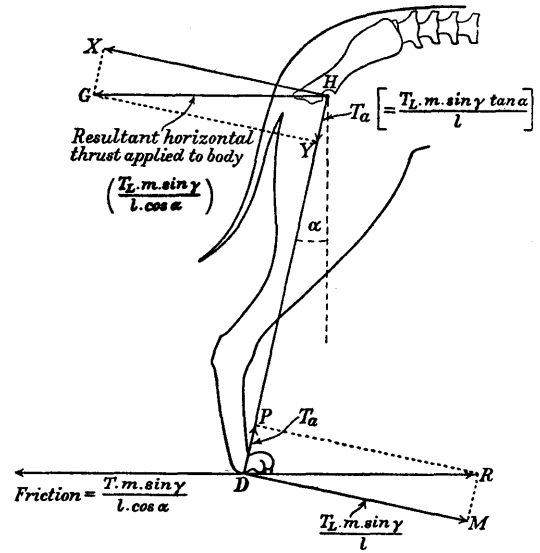

Fig. 50. Diagrams showing equal and opposite effects on a limb and on the body of the forces due to the weight of the body (fig. *a*) and those due to a suitable extrinsic muscle (fig. *b*). In fig. *a*, V_B is the resultant of the vertical thrusts from the three remaining limbs and of the total weight of the body. By acting as a strut the limb applies a force $V_H = V_B$ at the hip; the body is therefore subjected to a couple $V_H x$ and to an anterior horizontal thrust $V_H \tan \alpha$. In fig. *b* the limb exerts equal and opposite effects by tension (T) developed by a protractor muscle. Equilibrium is established when $Tx = V_H x$, the moment of the couples exerted by the muscle on both the body and on the limb being equal but opposite to those due to the weight of the body; the couples acting on the body are (V_H, V_B) and (OP, RT) .

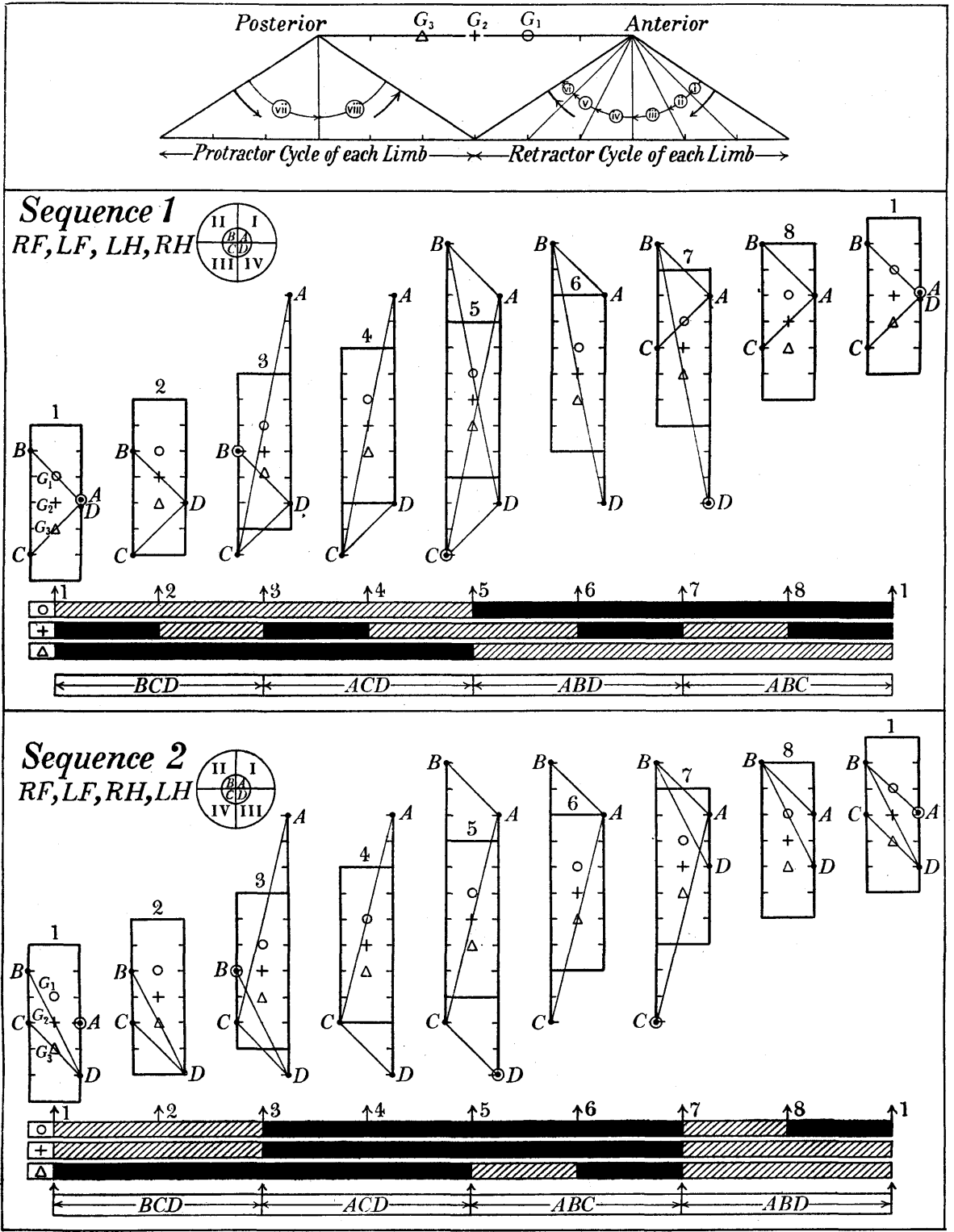
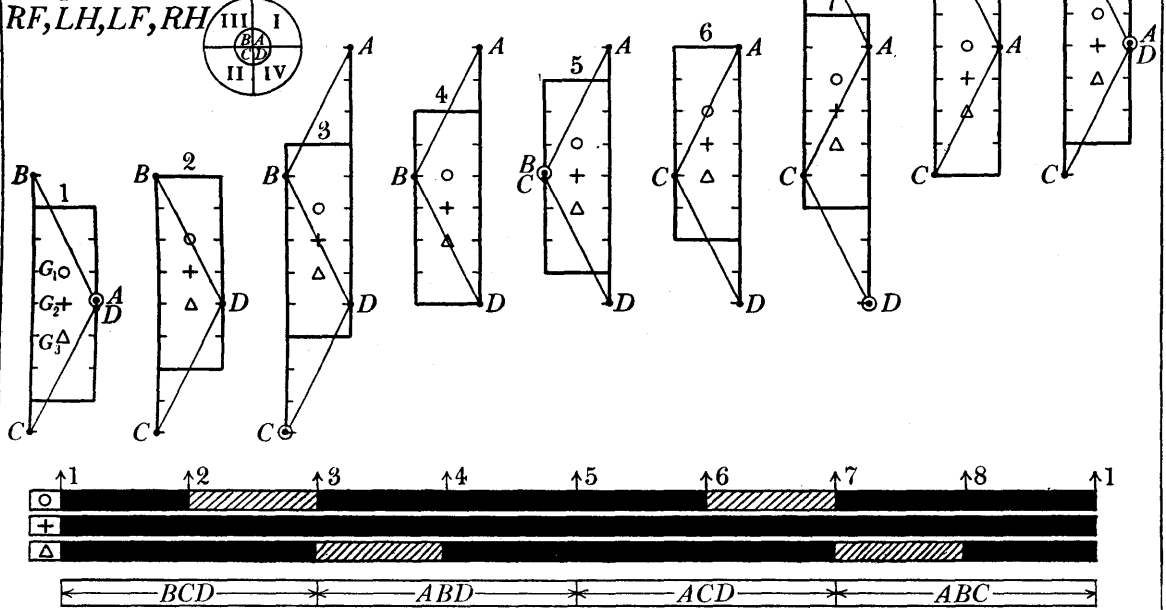

Fig. 51. Diagram showing that only the diagonal sequence (*RF, LH, LF, RH*) of limb movements is consistent with complete stability of the body at all phases of the locomotory cycle. The six possible sequences (1-6) refer to an animal in which (i) there are always three, but never more, feet in contact with the ground; if therefore the complete retractor cycle of a limb's movement is divided into six phases (i-vi) of equal time duration, the duration of the complete protractor cycle must be divisible into two such phases (vii and viii); (ii) protraction and retraction of the axes of the limbs are symmetrical about the vertical posture and the stride is equal to the length of the body;

Sequence 3

RF, LH, LF, RH



Sequence 4

RF, LH, RH, LF

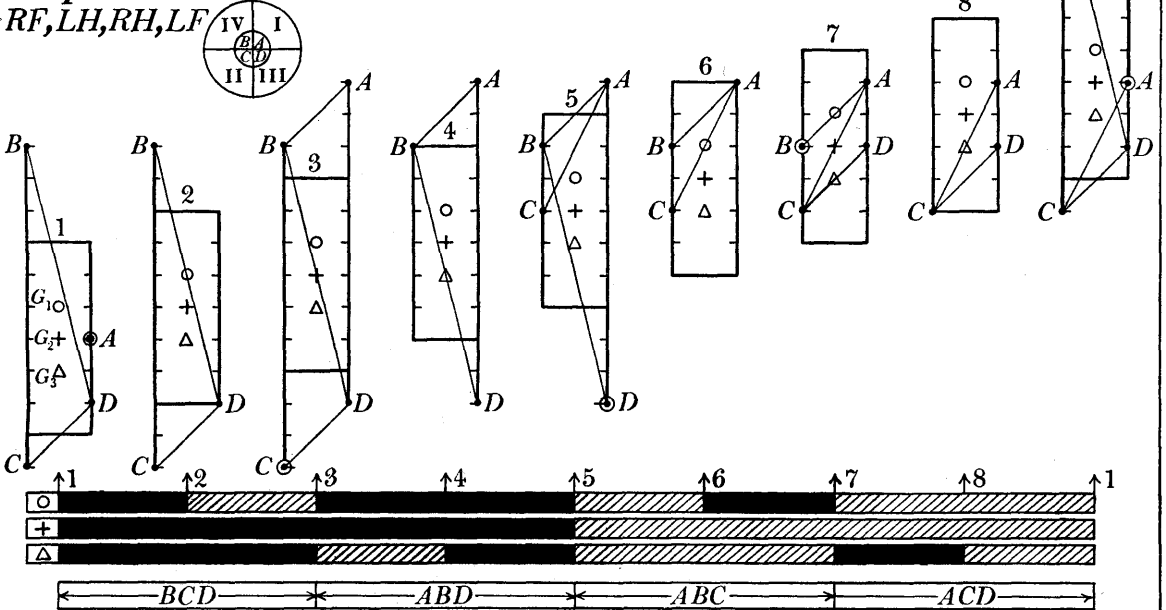

(iii) the speed of progression of the body is constant; (iv) the centre of gravity of the body is at G_1 , G_2 or G_3 . These conditions are summarized in the elevation diagram at the top left-hand corner of the figure.

For each sequence of limb movements the initial posture of the feet is that characteristic of the sequence when the right fore limb is fully retracted; each of the successive eight phases is shown by displacing the whole system to the right by a constant distance. In each instance, therefore, the position of the feet relative to the ground and to the centre of gravity of the body can be noted. The three horizontal panels below each sequence show the periods

Sequence 5

RF, RH, LF, LH

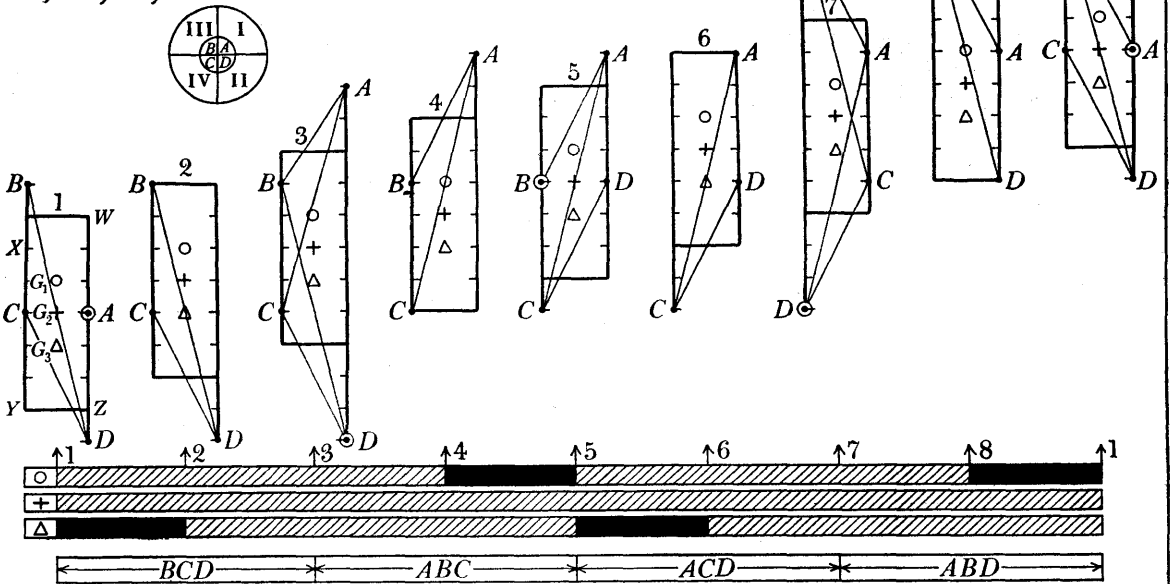

Sequence 6

RF, RH, LH, LF

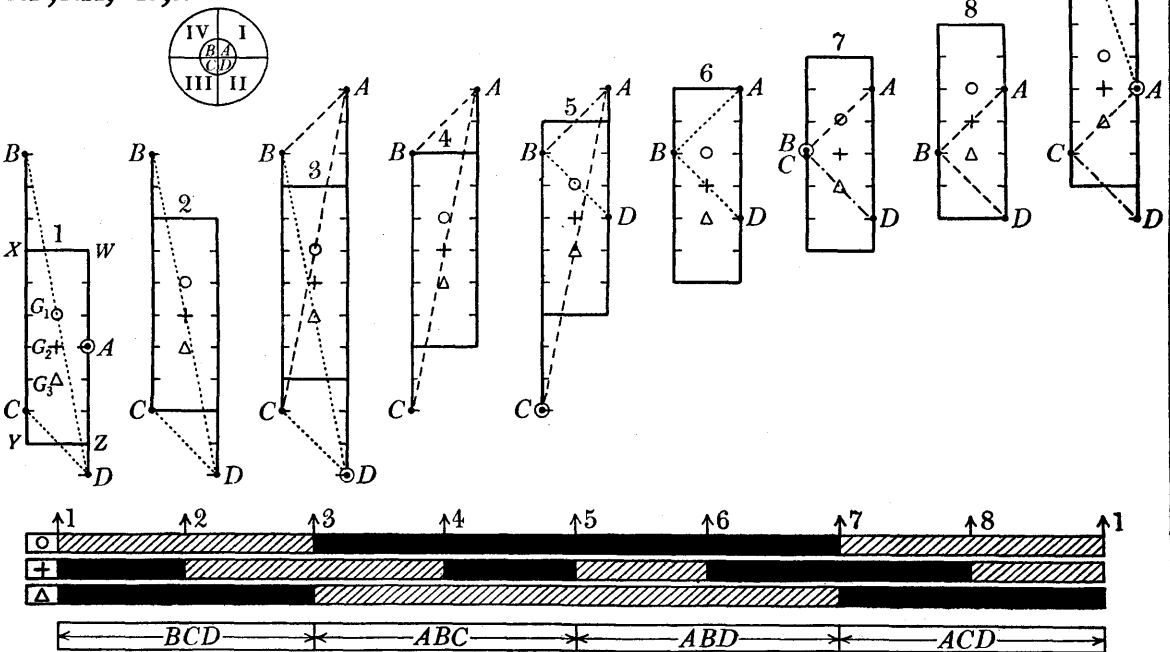

during which the centre of gravity of the body falls, or does not fall, within the triangle of the supporting feet; **■** stable, **▨** unstable. The fourth horizontal panel shows the triangle of feet supporting the body at various phases of the whole locomotory cycle.

Note that complete stability is only provided by the diagonal sequence (III), and then only if the centre of gravity of the body lies at G_2 .

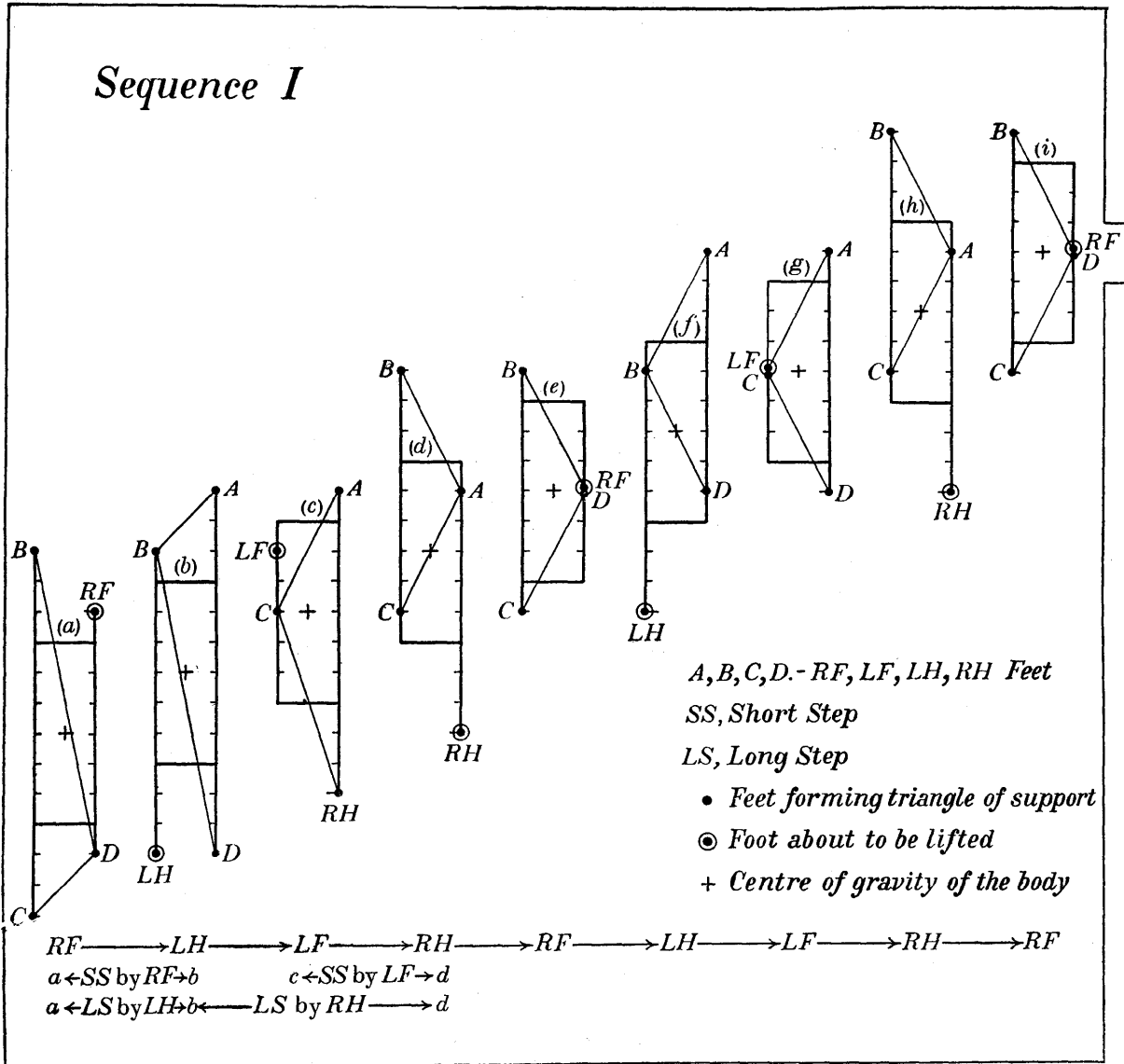
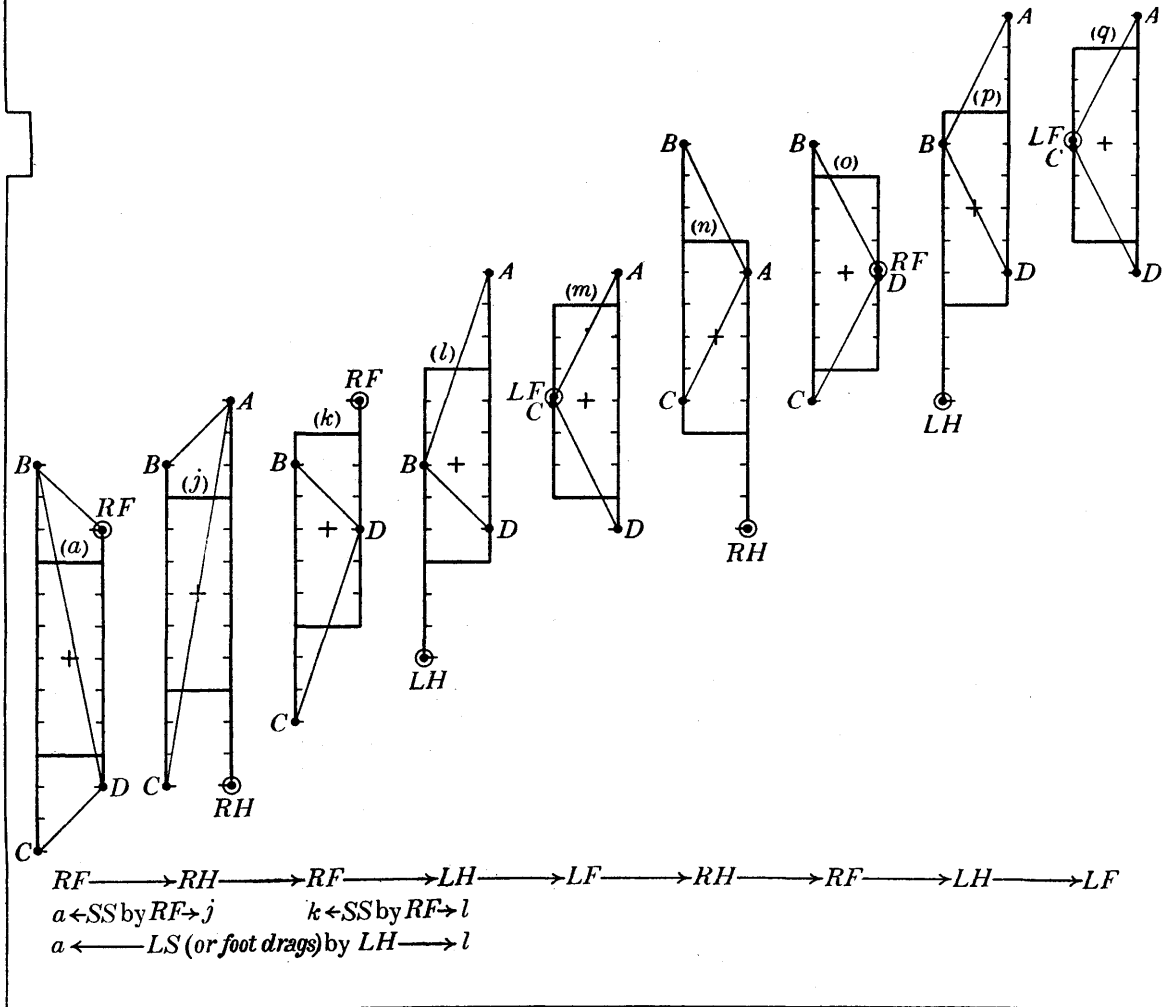

Fig. 52. Diagram illustrating the dependence of slow stable locomotion on the diagonal sequence of limb movements. In each of the three sequences (I-III) shown the initial relative positions of the feet (*a*, *a*, *r*) are identical and represent a stage in the unstable rotary sequence (I) of Fig. 51, viz. *LH*, *RH*, *RF*, *LF*. The three sequences shown in Fig. 52 show the three possible results of moving a foot only when a triangle of support is provided by the other three limbs.

In the initial position a triangle of support can be provided either by *BCD* (*a*, sequences I, II) or by *ABC* (*r*, sequence III). Using the triangle *BCD*, the *RF* foot can be advanced whilst the *LH* foot either extends further

Sequence II



or (as is shown in the diagram) drags over the ground; the posture of the feet shown in *b* (sequence I) and *j* (sequence II) is thus reached. In this position a triangle of support can either be provided by *ABD* (sequence I) or by *ABC* (sequence II), so that either the *LH* (sequence I (*b*)) or the *RH* (sequence II (*j*)) can be lifted, thereby giving postures *c* and *k* respectively. From these stages onwards there is, at each successive phase, only one limb which can be moved, viz. that shown in the diagrams; the diagonal pattern automatically emerges.

If a triangle of support for the animal in its initial position is provided by *ABC*, the sequence of events is shown in sequence III; again, the diagonal pattern emerges.

Sequence III

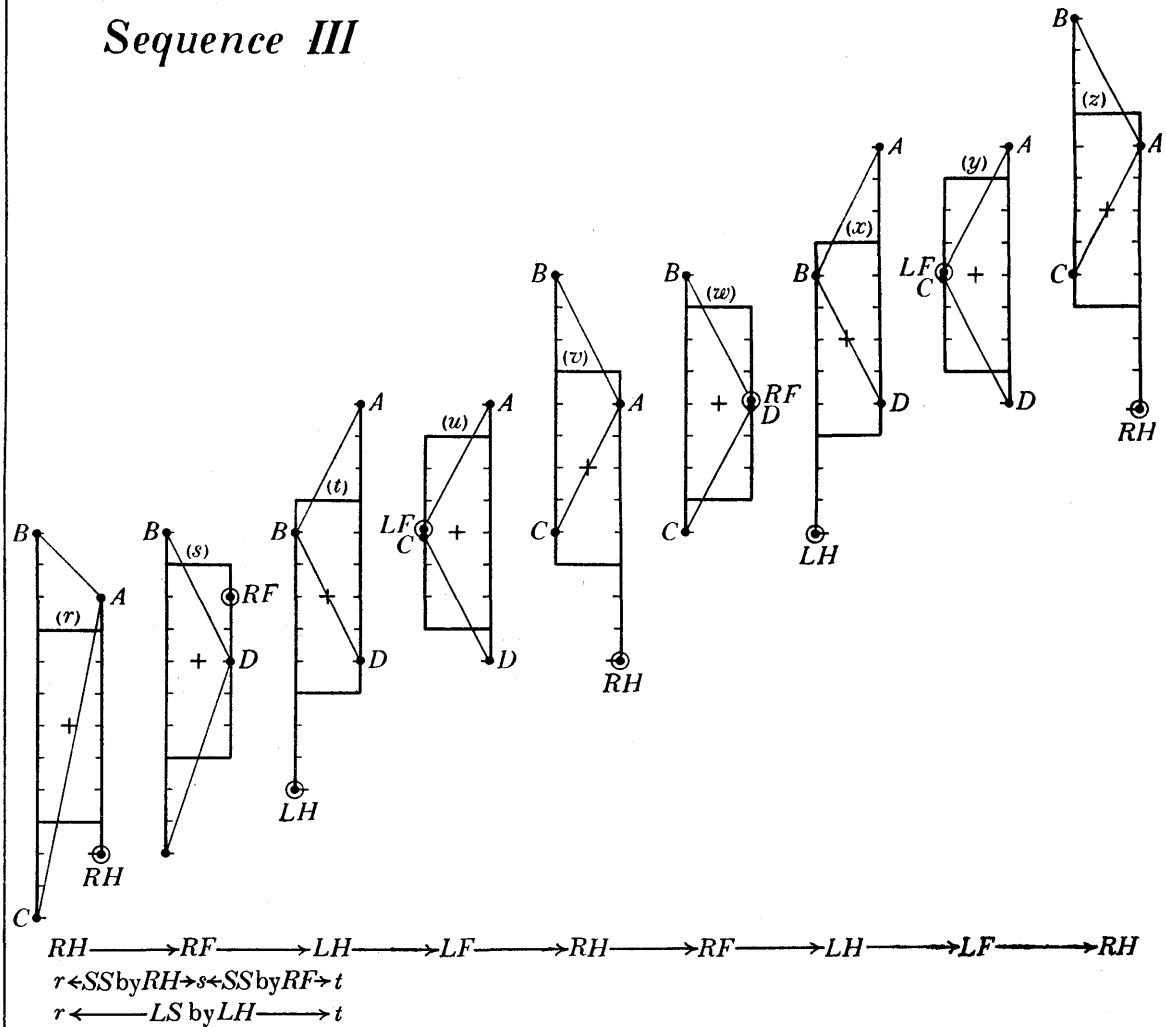

The following points may be noted: (i) The readjustment in the relative phasing of the limbs is established by certain limbs stepping short and others either taking long steps or dragging over the surface of the ground. In nature adjustment is established by altering the relative length of the steps taken by individual limbs, but in spinal preparations of newts the dragging of limbs over the ground is a well-defined phenomenon prior to the establishment of the diagonal pattern. (ii) The transitions from phase *a* to phase *b* or *j* represent phases of momentary instability. Strictly speaking, sequence III is the only fully stable sequence, but as momentary phases of instability are nearly always present in natural locomotion, sequences I and II are of practical significance.

■ vertically under the centre of gravity of the body) by a distance $p = \frac{ax_4 - bx_1}{x_1 + x_4}$. To neutralize this pitching moment about the front limbs, the centre of pressure of the left side must lie at G_2 (Fig. 23b) and the distribution of weight between the two left feet (V_2 and V_3) must be

$$V_2 = \frac{W}{2} \left(\frac{x_4 + b - p}{a + b + x_1 + x_4} \right), \quad V_3 = \frac{W}{2} \left(\frac{x_1 + a + p}{a + b + x_1 + x_4} \right).$$

If both these limbs act as struts the horizontal thrusts imparted to the body are

$$H_2 = \frac{W}{2} \left(\frac{x_4 + b - p}{a + b + x_1 + x_4} \right) \frac{x_1}{h},$$

$$H_3 = \frac{W}{2} \left(\frac{x_1 + a + p}{a + b + x_1 + x_4} \right) \frac{x_4}{h},$$

$$H_3 - H_2 = \frac{Wh}{2} \left[\frac{ax_4 - bx_1 + p(x_1 - x_4)}{a + b + x_1 + x_4} \right].$$

To provide a posterior horizontal force $H_3 - H_2$ the moment (M_1) of the protractor muscles of the left hind limb must be

$$M_1 = \frac{W}{2} \left[\frac{ax_4 - bx_1 + p(x_1 + x_4)}{a + b + x_1 + x_4} \right].$$

Substituting for p

$$M_1 = W \left[\frac{ax_4 - bx_1}{a + b + x_1 + x_4} \right].$$

Clearly the moment of the left hind protractor muscles is the same as the combined moments of the right and left side protractors shown in Figs. 22 *a, b*. In other words, by altering the vertical loading of the limbs the strain on the extrinsic muscles of the right side has been shifted completely on to those of the left side.

GENERAL SUMMARY

1. From a mechanical point of view the organization of a tetrapod's body is essentially that of a segmented, flexible and overhung beam supported by four limbs; each limb can operate both as a strut and as a lever. A substantial number of physiological and morphological facts receive rational explanations when subjected to mechanical considerations imposed by the animal's own weight.

2. The general conditions under which a tetrapod can use any particular limb for purposes other than the support or propulsion of the body depends on the positions of the four feet relative to the centre of gravity of the body.

When a cursorial tetrapod is standing on four legs, the contribution which any one limb makes towards the support of the body can vary within limits which can be defined in terms of (i) the weight of the body, (ii) the positions of the centres of pressure of the four feet relative to the centre of gravity of the body. If the thrust of one limb is known that of each of the other three can be calculated.

3. If the vertical thrust of any one limb be increased, there must be a simultaneous increase in the thrust of the diagonally situated limb and a decrease in the thrusts of both feet situated on the

other diagonal. The reflex myotactic response of mammalian extensor muscles to mechanical stretch provides an adequate mechanism for ensuring effective co-ordination between the vertical thrusts exerted by each of the four limbs. The physiological response of all the limbs to flexor stimulation of any one of them conforms to the mechanical requirements for stability; it probably represents an extreme instance of readjustment of limb thrusts.

4. In bipedal forms a quadrilateral of support is provided by the heel and toes of the two feet: the conditions of stability are essentially the same as in tetrapods.

5. If a tetrapod stands on an inclined slope (in a posture similar to that normally adopted on a horizontal surface) the extent of the resultant redistribution of weight between front and hind feet is inversely proportional to the relative length of body and limbs. A long low body is a mechanical adaptation to a scansorial habit. The typical postures adopted by tetrapods when standing on steep slopes (viz. either with the axes of the limbs retracted or the back horizontal and the hind limbs flexed) conform to the principle that the distribution of the total weight of the body between the various limbs should approximate closely to that characteristic of the animal standing in a normal posture on a horizontal surface. The same principle applies to the posture adopted by an animal when exposed to restraint by an extraneous horizontal force.

6. The limbs of a tetrapod can contribute towards the support of the body either in the capacity of struts or in the combined capacity of struts and levers. When acting as a strut a limb exerts forces along its own mechanical axis only, the moment of the muscular tensions operating about the hip or shoulder joint being zero. When a limb is acting as a lever the limb exerts both against the body and against the ground forces at right angles to its mechanical axis; it is able to do so by means of the muscles whereby the limb is attached to the body.

7. When a limb is acting as an inclined strut the couple which is exerted on it by the weight of the body must be compensated by a couple due to (i) a horizontal force exerted on its proximal end by the body, and (ii) friction or other horizontal force acting at the foot. The horizontal force acting on the proximal end of the limb represents the resultant horizontal force exerted on the body by the three other limbs. Instances are described of two or more limbs co-operating, either as longitudinal or transverse struts, for the support of the body.

8. When subjected to tension from a muscle originating on the body, a limb operates as a lever and exerts equal but opposite horizontal forces against the ground and against the body. At the same time it exposes the body to a turning couple whose moment is equal to that of the muscle's tension about the centre of rotation of the joint.

By means of the muscles which operate between

the body and the limb an animal can control the horizontal forces exerted by a limb against the body and against the ground.

9. The muscular co-ordination between two or more limbs, acting as levers, is described. For any given position of the feet relative to the centre of gravity of the body, the minimum total muscular effort required to maintain equilibrium is always the same. The distribution of this effort between the muscles of the various limbs can, however, be varied between relatively wide limits, either by changing the tension of one or more extrinsic muscles or by changing the distribution of weight between the feet by a change in the axial thrust of the limb. The whole of the limb musculature of the animal must be regarded collectively as one functional unit.

10. The particular pattern of muscular activity adopted for any given posture and loading of the limbs is probably such that the strain is distributed between the relevant muscles in proportion to their ability to develop and sustain tension.

11. The quantitative muscular effort required for the stabilization of any limb joint depends on the magnitude and direction of the reaction of the ground against the foot and on the distance of the centre of rotation of the joint from the line of action of this force. Since the reaction of the ground against the foot is under the control of the animal, the latter can continue to stand whilst varying the strain falling on any one intrinsic or extrinsic muscle provided it readjusts the activity of all the others not only in the same but also in all the other limbs. Instances are given of the co-ordination of the musculature in the four limbs of an animal standing at rest.

12. The digitigrade habit is associated with a posture of limbs in which the line of action of the body weight passes anteriorly to the distal metacarpal or metatarsal joints.

13. The forces exerted on joints by curvilinear muscles are discussed. In general the centripetal pressure exerted by the muscle is equal and opposite to the resultant longitudinal thrusts exerted by the two main bones composing the joint. Brief reference is made to multi-joint muscles.

14. The nature of the strains imposed on the vertebral column by the weight of the body and by the forces exerted by the ground against the feet of a tetrapod are discussed.

15. The mechanical picture presented by a tetrapod is essentially that of a flexible overhung beam supported by four elastic legs; only under very special circumstances can the body be compared to two balanced centilevers.

16. By means of the muscles of its limbs an animal can increase or decrease the strain falling on its vertebral musculature or vice versa.

17. As a propulsive mechanism, the limb of a tetrapod functions as an extensible strut and as a lever. In so far as it acts as a propulsive strut, the limb is extended by its own intrinsic musculature and the mechanism of locomotion is essentially that of a punt when propelled by a pole. In so far as the limb functions as a lever, it is operated by its extrinsic musculature and the mechanism is essentially similar to that of a canoe propelled by a two-handed paddle, the distal end of which remains fixed.

18. In so far as it operates as a strut any limb in a retracted posture exerts a propulsive action; a similar limb in a protracted posture exerts a braking action. In both cases the horizontal force acting on the body depends on the axial thrust of the limb's musculature and on the angle of inclination of the limb. The propulsive or braking action of a limb operating as a strut can be increased or decreased by the operation of the limb as a lever. During each cycle of movement a limb alternately acts as a brake or as a propulsive element; over the whole cycle the fore limbs of a cursorial mammal probably exert a resultant braking action whereas the hind limbs have a resultant propulsive action.

19. The diagonal co-ordination of limb movements seen in nearly all tetrapods enables the limbs to propel the body forwards with a minimum of uncompensated pitching or rolling couples. It is in fact the only pattern of movement which enables the body to be in static equilibrium with its own weight at all phases of the movement; the animal can therefore come to rest at any point without falling over.

20. The forces acting on the body and at the feet of a moving animal are discussed, and brief reference made to the relative importance of front and hind limbs as organs of propulsion.

21. The locomotory significance of the axial musculature of the vertebral column is described.

Summaries of §§ I-VI will be found on pp. 97, 102, 106, 108, 113.

REFERENCES

- GRAY, J. (1940). *Proc. Roy. Soc. B*, **128**, 28.
 GRAY, J. & LISSMANN, H. W. (1940). *J. Exp. Biol.* **17**, 237.
 LIDDELL, E. G. T. & SHERRINGTON, C. S. (1924). *Proc. Roy. Soc. B*, **96**, 212.
 MANTER, J. T. (1938). *J. Exp. Biol.* **15**, 523.
 RADEMAKER, G. G. L. (1931). *Das Stehen*. Berlin.
 SHERRINGTON, C. S. (1906). *The Integrative Action of the Nervous System*. London.
 STEWART, D. (1938). *J. Anat., Lond.*, **72**, 101.
 THOMPSON, D'ARCY W. (1942). *Growth and Form*, 2nd ed. Cambridge.
 TATE REGAN, C. (1936). *Natural History*. London.