

# Study of a Home Robot: JIBO

Pranav Rane, Varun Mhatre, Lakshmi Kurup

Dept. of Computer Engineering  
D. J. Sanghvi College of Engineering  
Mumbai, India

**Abstract**— JIBO is a robot built to function in a home environment. It is based on an Artificial Intelligence and Natural Language Processing that learns and adapts over time. It is essentially the first ever family robot. It is currently being developed by Dr. Cynthia Breazeal at JIBO Inc. It is going to be available to the general public by early 2016 for 349\$. It is a device that can connect to the JIBO Cloud using Wi-Fi and can connect to smartphones using Bluetooth. It is primarily designed to interact with family members in the most human way possible. Apart from understanding natural voice commands, it can take pictures, read emails, assist in video conferencing and implement smart home concepts. This paper will let us understand the scope of this device into our lives.

**Keywords** — JIBO, home robots, smart home, artificial intelligence, Robot, natural language processing

## I. INTRODUCTION

Sci-Fi movies have always portrayed a home robot that performs all the tasks associated with a home and is something close to a behaving like a human being. Such robots could perform difficult and repetitive tasks with ease. Apart from being mechanically efficient, they could talk and respond to human interactions just like any other human would. But these are either fiction or at least a decade away from being in the general public's homes. The closest we came to achieving a stable and human like AI was Siri in 2011. Apple announced Siri and it took the world by storm. Siri was the first publicly available Artificial Intelligence. Right then the general public loved the idea of a device that can talk, think and respond in real time. What makes Siri still so special is its personality. Siri is designed with quirky and lovable features. So interactions seem fun and real at the same time. But Siri is still far away from the Sci-Fi dream. To bridge the gap JIBO is conceptualized and designed.

Now JIBO Inc. takes the first step by designing a production ready home robot with an AI and a body. Even though it will not be able to perform any mechanical tasks like the robots from Sci-Fi movies it will still manage to interact with humans, just like any other human would. This will make conversations much more natural as humans no longer have to deal with just a voice. JIBO currently defines a new product category i.e. Domestic Robots. Even though it will be the first product of such a category, its concept is potentially life-style altering. It is designed to be ubiquitous in a home environment and its objective is to make everyday interaction with technology easier and reliable.

JIBO will feature a voice activated system and touch screen to make interactions with humans simpler. It is designed to always stay on, and listen for keywords that will

activate its computation. As the user asks questions JIBO will give audio output and will display content related to the query. Users will be notified of their email, texts or voice messages as and when the user is in proximity of the device. Thus it becomes a hands-free helper for every family member.

It is designed so that it will communicate and express using natural social cues.

## II. DESCRIPTION

The robot will be based on a 3-axis motor system that allows the robot to rotate 360°. The three major parts of JIBO work together to achieve such movement. The design allows the robot to look up and look down. The screen on top of the rotating base is an HD-LCD screen. Thus content will be displayed without any loss in quality of picture.

Touch screen would work on the screen and around the edges of the screen. Even though there is no functional use to have a touch screen around the edges, it is primarily designed to interact with the device. Human-like actions such as patting can be performed around the edges and JIBO will respond with highly specific human like responses.

It will have two high resolution cameras that will be able to track faces and emotions. It also will have 360 degrees microphone. It will have two speakers to provide its output.

JIBO is designed to be constantly plugged in. It will always need a power-source like a personal desktop. Batteries will be separately available and its battery life is 30 minutes. Its processor is based on ARM and its platform is Linux based. Developers in the future can make JavaScript-centric apps for the JIBO store. Consumers can purchase apps from the JIBO Store.



Fig 1. Structure Of JIBO

TABLE 1. Hardware Specifications for JIBO

Hardware	Specifics
Size	approx. 11" tall, 6" base
Weight	approx. 6 lbs.
Material	aluminum, ABS plastic, glass
Sensors	2 color stereo cameras 360° sound localization full body touch sensors
Movement	3 full-revolute axes high resolution encoder feedback control
Display	HD LCD touchscreen
Sound	2 premium speakers
Lighting	full-spectrum ambient LED
Language	US English
Power	AC adapter & battery-ready
Connectivity	Wi-Fi & Bluetooth
Platform	embedded Linux-based
Processor	high-end ARM-based mobile

### III. FEATURES

#### A. Smart-Connected Home

JIBO is a connected device. It will connect to the JIBO cloud using WIFI. The user generated content is stored in the cloud. This may include images, videos, audio clips etc. If users have signed into their Email addresses and social networking websites then JIBO can provide notifications about them. Apart from this user can also receive calendar notifications from JIBO. The notifications will only be provided when the user is around the device. Hence data cannot fall into the wrong hands. User can be authenticated using Facial Recognition. Hence user can be updated effortlessly and in time.

JIBO will also be able to connect to Android and IOS smart phones using Bluetooth. All devices that support JIBO app can communicate with JIBO. JIBO app will also allow users to peruse through their JIBO generated content globally. JIBO app will also allow users to connect to JIBO for features such as Video conferencing. Apart from smartphones JIBO will also be able to connect to personal computers and other JIBO's.

Further JIBO is designed to learn and adapt to user's needs. JIBO can connect to other smart devices like smart bulbs and air conditioning and control them. In this case is JIBO expects the user to come home around 9pm (user can set this time) then around 9pm smart lights will be switched on, air conditioning can begin working before 9. These features can save the user time and effort. At any time user suspend these automated processes using the JIBO app. JIBO also learns from your previous habits and can help placing orders for food or give user notifications about package delivery.

JIBO can authenticate user using face (Facial Recognition), voice (Speaker Identification) or cell phone (Bluetooth Information). Although each has its significant role, Face-Recognition will be the most used in day to day life.

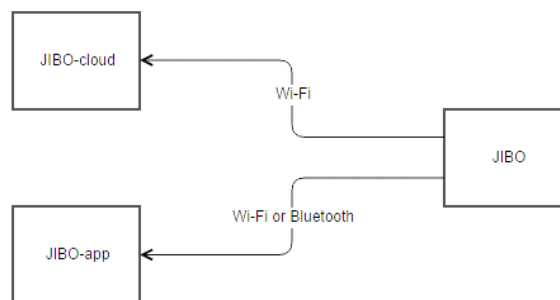

Fig 2. Connectivity For JIBO

#### B. Camera Applications

By default JIBO will have rich camera applications. It will have the ability to identify people uniquely using Facial Technology. This technology will further be expanded and used to track faces. It will be able to track emotions like smiling, frowning. Camera will also able to detect the distance of the user from JIBO. Using voice commands, user can tell JIBO to take a picture. JIBO will find the humans in the nearby vicinity and once faces are identified picture will be clicked. All the aforementioned features will be used while taking pictures.

JIBO's camera can also be used for video conferencing. Using the JIBO app, people can connect to a JIBO. Once connected, user on the Non-JIBO side has to use the JIBO app. The app will then use the front camera of the smart phone tablet to show app user's to people on the JIBO side. On the JIBO, people can see the person's face on JIBO's screen. This feature is named by the makers as the 'avatar feature'. By default JIBO will show the face of the person speaking near it. To track the speaker efficiently JIBO uses its 3-axis mechanism. JIBO can move 360 degrees and hence show the speaker efficiently. The user on the non JIBO side can choose the track speaker option or can track only a specific person.



Fig 2. JIBO's Avatar Mode



Fig 3. JIBO's Photographer Mode

### C. Other Features

Multiple JIBO's will be able to communicate among one another using emoticons. Hence, users can communicate with each other in a simple and fast mechanism.

JIBO will also contain 'family watch skill'. Users can hence use this to keep a watchful eye on kids, pets. It can also expand as a security tool. But to use JIBO as a security tool, users will have to pay additional subscription charges and other monthly charges. Security footage will be available on JIBO cloud and can be accessed using the app. By December 2015 several personalization tools will be released for JIBO.

## IV. SECURITY

When a device like JIBO which has access to content related to personal, family members, it becomes very important to safeguard the data generated. JIBO uses SSL encryption that will secure personal data sent to and from the cloud; JIBO will use 256-bit AES (Advanced Encryption Standard) encryption in the cloud; and Digital certificates will be used to authenticate devices.

A good combination of technology and company policies will be used to protect user's personal data. JIBO complies with FTC Bureau of Consumer Protection guidelines. That also includes the Children's Online Privacy and Protection Act (COPPA). Company policies will ensure that JIBO only collects specific data deemed necessary, keeps it secure, and retains it only as long as required. A company security officer will review security of all customer data in all phases of use.

JIBO will employ industry standard best practices regarding the way data is stored and transferred. Passwords will be stored using cryptographic one-way hash functions. This ensures that no entity, even the company security officer, could ever gain access to a users' password. JIBO would store certain information about users and back it up to the cloud. It will be encrypted via Secure Sockets Layer (SSL) when being uploaded or downloaded from the cloud. While stored in the cloud it will be encrypted via 256-bit AES. The information stored could include user's name, information required to connect to your Wi-Fi network, various preferences, and data that is acquired through one of the JIBO applications or apps. Such data includes photos, videos, lists and preferences.

Camera and microphone cannot be activated without specific permission from the users.

## V. APPLICATION DEVELOPMENT

The apps for JIBO will be called 'Skills'. They will be available on the JIBO Store and can be downloaded by JIBO users. The JIBO store will open by December 2015.

All users that purchase JIBO will have JIBO Alive Toolkit. The developer edition of JIBO will be available separately from third quarter (Q3) of 2015. The JIBOalive Software Development Kit (SDK) will be available with it. The SDK can be used by developers to develop apps and new functionality that can be added to the JIBO. The developers can submit their apps and the certified apps will appear on the store. Developers will be part of JIBO Developer program and will have direct access to support and help from the core manufacturing team.

JIBOalive Toolkit will include:

- Web-based visual JavaScript programming tool, animation-creation tool, and virtual simulator to test apps
- Library of animations, sounds, vocalizations to enhance experience for future app users
- Text-to-speech (TTS) tool for JIBO's voice

JIBOalive SDK includes everything in the JIBOalive Toolkits. It will also include:

- JavaScript API access to JIBO's sensory systems
- Eclipse plugin
- Sample source code

The Programming interface is designed to be simple so that many people can develop apps and improve the experience. The programming platform can be compared to the children's programming language 'Scratch.'

JIBO's software is built on Linux, but its subsystem will proprietary for now.

## VI. ADVANTAGES AND DISADVANTAGES

JIBO is primarily designed to become another family member. If all the aforementioned features are available by 2016, it will achieve its goal. Its hands free and easy-to-use design will become very popular with users. Its features are good for people that are busy and cannot handle multiple devices at once. For such people all their information will be available in an easy way.

JIBO is also the first of a new product type. If JIBO is accepted by the general public then big tech companies will also invest in home robots, thereby bringing a shift in our lives. This shift will lead to seamless integration of technology and human life at a lesser price. Hence the possibilities with JIBO are limitless.

On the downside, this technology is still new. In such times, investing 349\$ in brand new technology might be an act of folly. Also this device is still in its early stages, so the specifications of this device could change in 2 years. The firm producing this device is new and has never handled a

device of this magnitude. Also the product has no wheels and hence cannot move. Carrying an 11 pound device from one room to another does not make a lot of sense. Batteries are not included and have to be bought separately. Apart from that the battery life is only 30 minutes. That is really low compared to modern devices.

#### VII. CONCLUSION

The product definitely shows a lot of potential and a lot of promise. Even though the team developing it is new, they are very qualified. If the price is reduced over time and apps increase this product could be in a lot of homes in the next 5-7 years.

#### ACKNOWLEDGMENT

We would like to thank our honourable principal Dr. Hari Vasudevan of D. J. Sanghvi College of Engineering and Head of Department of Computer Engineering, Dr. Narendra Shekhokar for giving us the facilities and providing us with a propitious environment for working in college. We would also like to thank S.V.K.M. for encouraging us in such co-curricular activities.

#### REFERENCES

- [1] <https://www.indiegogo.com/projects/jibo-the-world-s-first-family-robot>
- [2] <http://www.myjibo.com/>
- [3] <http://fileformats.archiveteam.org/wiki/JIBO>
- [4] <http://blog.myjibo.com/>
- [5] <http://atmelcorporation.wordpress.com/2014/07/18/meet-jibo-the-worlds-first-family-bot/>
- [6] <http://linuxgizmos.com/cheery-social-robot-owes-it-all-to-its-inner-linux/>

IJERT