

Study of Adjustable Gains for Control of Oscillation Frequency and Oscillation Condition in 3R-2C Oscillator

Roman SOTNER¹, Jan JERABEK², Norbert HERENC SAR²,
Zdenek HRUBOS¹, Tomas DOSTAL^{1,3}, Kamil VRBA²

¹Dept. of Radio Electronics, Brno University of Technology, Purkynova 118, 612 00 Brno, Czech Republic

²Dept. of Telecommunications, Brno University of Technology, Purkynova 118, 612 00 Brno, Czech Republic

³Dept. of Electronics and Informatics, College of Polytechnics Jihlava, Tolsteho 16, Jihlava 586 01, Czech Republic

{sotner; jerabekj; herencsn; dostal; vrbak}@feec.vutbr.cz, xhrubo00@stud.feec.vutbr.cz

Abstract. An idea of adjustable gain in order to obtain controllable features is very useful for design of tunable oscillators. Several active elements with adjustable properties (current and voltage gain) are discussed in this paper. Three modified oscillator conceptions that are quite simple, directly electronically adjustable, providing independent control of oscillation condition and frequency were designed. Positive and negative aspects of presented method of control are discussed. Expected assumptions of adjustability are verified experimentally on one of the presented solutions.

Keywords

Electronic tuning, adjustable current and voltage amplifiers, voltage and current followers, oscillators.

1. Introduction

Many active elements that are suitable for analog signal processing were introduced in [1]. Some of them have interesting features, which allow electronic control of their parameters. Therefore, these elements have also favorable features in applications. There are several common ways of electronic control of parameters in particular applications. One of the basic approaches is based on replacing grounded or floating resistors in so-called single-resistance-controlled oscillator types (SRCO) [2]-[6], where resistors can be replaced by FET [3]. It could be useful, if there are solutions of active element that allows direct control of any parameter. Control of bias current and therefore of the input resistance is also very popular [7], [8] nowadays. Bias control of transconductance (for example [9-11]) and application of electronically adjustable gain in current conveyors and similar active elements [1], [12]-[20] is another way for direct electronic adjusting. Recently introduced adjustable current transfers in feedback loops [21], [22] of electronic circuit are very suitable not only for the design of adjustable filters, but also for oscillator synthesis. We can recognize two general ways of control.

Direct control means that the functional block is adjustable (tunable) by externally controlled parameter(s) of active element (i.e. current gain, intrinsic resistance, transconductance, etc.). Indirect control is usually provided by some kind of controllable replacement. Simple resistor is replaced by FET transistor, digital to analog converter, or digital potentiometer, etc.

The most important active elements for our approach are current followers (CF) [1], [23], current amplifiers (CA) [1], [24], [25], and voltage buffers/followers (VB/VF) [1]. Many applications were focused on current mode filters (for example [26]-[28]) or inductance simulators (for example [24]). There are also attempts to control some of the parameters digitally and therefore the digitally adjustable current amplifier (DACA) was introduced in [26], [27]. The use of digitally controlled current transfers was given in so-called Z-Copy Controlled-Gain Current Differencing Buffered Amplifier (ZC-CG-CDBA) [29]. Similarly, digital control was also used in case of differential current conveyors [30].

Current followers were used many times as basic elements of oscillators. Some important works that are following last development are discussed below. Chen *et al.* [31] introduced oscillator employing one CF with two capacitors and resistors providing quadrature outputs. However, condition of oscillation (CO) and oscillation frequency (f_0) are complicated and therefore conception is not suitable for electronic adjusting. Abuelma'atti [32] proposed conception with one CF and autonomous passive section, but CO and f_0 have complicated equation and parameters unsuitable for electronic control. However, the oscillator provides multiphase output responses. Similarly, Soliman [33] developed oscillator using CF and also VB. Finally, Gupta *et al.* [34] focused their research on adjustability in oscillator circuits based on CFs and presented solutions utilizing four CFs, three or four resistors, and two grounded capacitors. Their solutions allow tunability by single resistor (SRCO), as it is similarly shown in [35]. Lately, interesting conception was published by Martinez *et al.* [36], where three or four CFs, two VBs, three resistors, and two grounded capacitors in another SRCO type are used. Two multiphase SRCO oscillator realizations

with independent CO and f_0 control were recently introduced by Biolkova *et al.* [37], which also use the combination of two current followers/inverters and VBs, so-called current inverter buffered amplifier (CIBA), three and four floating resistors, and two grounded capacitors.

There are not many conceptions that use the possibility to control the current gain of active element. We can discuss and compare the following solutions: Souliotis *et al.* [38] used three electronically controllable dual-output CAs (integrators) in generalized arbitrary-multiphase current-mode oscillator as an example of directly electronically tunable oscillator. The oscillator is tunable by control current I_{bias} . Kumngern *et al.* [19] used current conveyor based integrators for generalized multiphase oscillator design similarly. The proposed conception is based on current conveyors with adjustable current gain between X and Z ports. Number of phases is reconfigurable by simple switches. Bias control of the current gain is used for matching of time constant of each integrator section. Synthesis and results are not focused on electronic adjusting oscillation frequency. Kumngern *et al.* [39] also proposed the circuit, where combination of intrinsic input resistance and current gain was used for f_0 and CO control. Electronic control of f_0 in [18] is possible by adjustable current gain, but CO control is available only by adjusting of grounded resistor. Solution in [18] employs only one active element, but its disadvantage is the dependence of one of produced amplitude on tuning process and nonlinear control of f_0 . The same type of f_0 control was also used in [40] and [41] in oscillators employing so-called Z-Copy Controlled-Gain Current Differencing Buffered Amplifier (ZC-CG-CDBA). Solution in [40] uses two active elements and five passive elements (capacitors are grounded). Discrete model of one active element employs four diamond transistors [42], [43], [61] and voltage buffer. It is not a problem for future on-chip implementation. Oscillation frequency is controllable linearly by current gain, CO and f_0 are mutually independent. Output amplitude is not dependent on tuning process and CO is controllable just by floating resistors. Solution in [41] requires two ZC-CG-CDBAs and 6 passive elements. CO is also controllable by floating resistor, but f_0 is adjustable digitally (dependence of f_0 on current gain is linear). In comparison to solutions presented in this paper, oscillators in [40], [41] require more sophisticated active elements (4-5 ports per active element). It is worth mentioning that our solutions require active elements that consist of only 3 ports and therefore final chip area of our solution in comparison with oscillators in [40] and [41] will be smaller. Subsequently, the power consumption is also significantly decreased. Oscillation frequency and condition of oscillation are controllable directly, electronically, and independently.

Oscillator solutions utilizing different active elements were presented in literature. Transconductor (OTA) [1], [9] is also useful active element for design of oscillators. We can discuss the following popular solutions. Directly electronically adjustable oscillators were proposed in [44]-[48]. Solutions use at least three active elements. Interesting

circuits were published in [48]-[51], where grounded and floating, two-four capacitor and three or four OTAs were used. Quite complicated solutions (many passive elements) were presented in [52] and [53]. Oscillator utilizing dual-output OTAs and four capacitors was discussed in [54]. Interesting current-mode types were published in [55]. Discussed solutions allow direct electronic control and independently adjustable CO and f_0 (in many cases). However, all OTA-based solutions have one important disadvantage: additional voltage buffering of high-impedance nodes is necessary, if we require voltage (low-impedance) outputs.

Typical representative of active element with similar type of low-impedance output (as our solutions) is current feedback amplifier (CFA) [1]. Oscillators consisting of two CFAs were widely investigated in the past. Important examples are included in [56]-[60]. CFA-based oscillators employing two active elements and grounded capacitors were proposed by Gupta and Senani in [59], [60]. Circuit topology with similar features is in Fig. 3 a, b in [60]. However, oscillators in mentioned literature [56]-[60] require additional voltage input (Y) of active element (CFA contains four ports - X, Y, Z, o) [1]. Our solutions use only current inputs and active element requires only three ports in contrary. Solutions presented in [59], [60] allow the control only by resistors (SRCO types). Direct electronic control with classical CFA is not possible. On the other hand, circuits in [59], [60] have some of resistors grounded when compared to our solutions, where all resistors are floating. Our approach uses direct electronic control (by the DC control voltage of active element) and characteristic equations contain different members and adjustable parameters of active elements. No additional circuit is necessary, except simple AGC.

Oscillator conceptions that are focused mainly on direct electronic control are presented in this paper. Oscillators provide the following important features: a) all capacitors are grounded (required for on-chip implementation); b) active elements with single current input and single voltage output are sufficient; c) only two active elements are required; d) independent control of oscillation frequency and condition of oscillations without mutual disturbance; e) f_0 and CO controlled without changes of any passive element; f) buffered outputs - no additional buffering is necessary; g) simple implementation of amplitude (automatic) gain control (AGC) for f_0 adjusting and satisfying total harmonic distortion (THD) - only rectified output voltage is required; h) real parts of current input (intrinsic) impedance of active elements are absorbed to values of working (external) resistors.

Above discussed solutions were the most important for our approach although many others were presented in literature. Current gain based approaches have not been frequently used for control the oscillators. It is clear that some of discussed solutions use less number of active elements, but direct frequency control and other advantages discussed below are not simultaneously allowed. Last

research was focused also on current-mode solutions (high-impedance outputs, for example [55]). Solutions providing voltage (low-impedance) outputs are discussed in this paper. Necessity of additional voltage buffers or current to voltage converters for voltage-mode operation is the most important problem of some previous works. Some hitherto published realizations are really economical (minimal number of active elements), but characteristic equation is not suitable for electronic control, active elements are quite complicated (many inputs and outputs), many of them do not provide quadrature outputs and in the most cases relation between produced amplitudes and total harmonic distortion in dependence on f_0 adjusting are not mentioned or investigated.

2. Elements with Controlled Gain

Biolkova *et al.* [37] introduced novel active element, so-called dual output current inverter buffered amplifier (DO-CIBA). Application field of such active element is very spread, but possibility of direct electronic control was not discussed (direct electronic control in the frame of the active element). We used several modified versions of DO-CIBA.

Symbol of so-called controlled gain current follower differential output buffered amplifier (CG-CFDOBA) [1] is depicted in Fig. 1 (a). The element contains four ports. Basic principle is explained in Fig. 1 (b). Low-impedance current input is labeled p , auxiliary high-impedance port as z , and buffered outputs (after voltage buffer/inverter) as $w+$ and $w-$, respectively. The output current at auxiliary port (z) is positive, which means that it flows out of the terminal. The current gain (B) between current input port (p) and auxiliary port (z) can be adjusted electronically via external voltage. Possible implementation of CG-CFDOBA with commercially available devices [62]-[66] is shown in Fig. 1 (c).

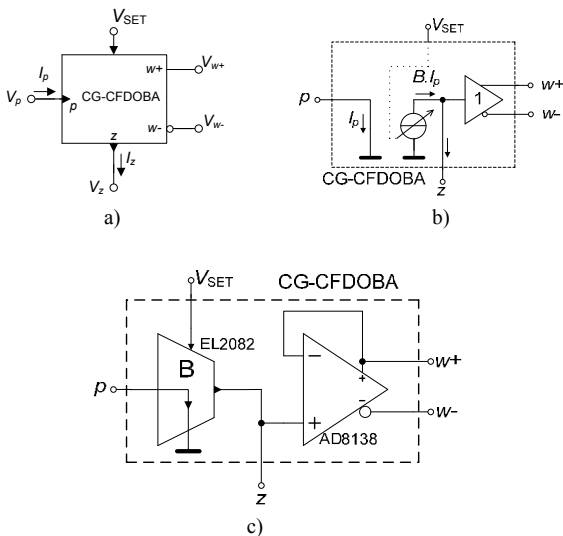

Fig. 1. Controlled gain current follower differential output buffered amplifier (CG-CFDOBA): a) symbol, b) behavioral model, c) possible implementation.

Simplified version (Fig. 2), where only one output w is necessary, should be also noted. This modification is usually called as controlled gain current follower buffered amplifier (CG-CFBA) [1]. Modification, where current at auxiliary terminal (Fig. 3) z is inverted, is marked as controlled gain current inverter buffered amplifier (CG-CIBA) [1], [37].

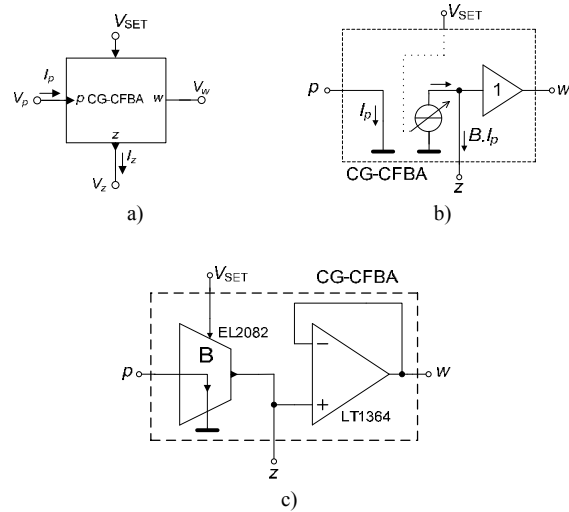

Fig. 2. Controlled gain current follower buffered amplifier (CG-CFBA): a) symbol, b) behavioral model, c) possible implementation.

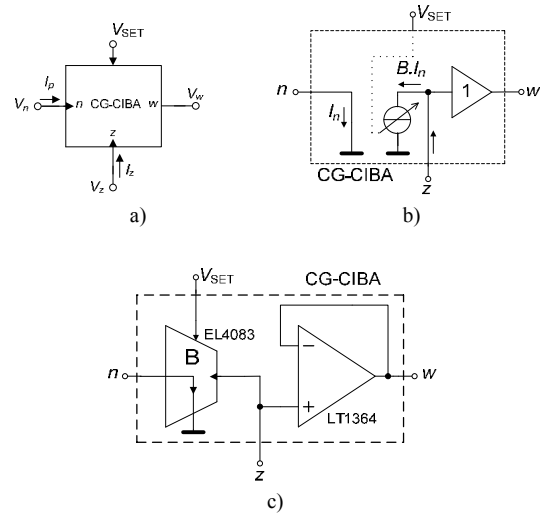

Fig. 3. Controlled gain current inverter differential output buffered amplifier (CG-CIBA): a) symbol, b) behavioral model, c) possible implementation.

The following hybrid matrices describe generally our intention in order to obtain adjustability very well. Equation (1a) describes the modified DO-CIBA with adjustable current gain (B), (1b) explains extension providing adjustable current (B) and voltage gain (A) simultaneously

$$\begin{bmatrix} I_z \\ V_{w+} \\ V_{w-} \\ V_p \end{bmatrix} = \begin{bmatrix} 0 & 0 & 0 & \pm B \\ 1 & 0 & 0 & 0 \\ -1 & 0 & 0 & 0 \\ 0 & 0 & 0 & 0 \end{bmatrix} \begin{bmatrix} V_z \\ I_{w+} \\ I_{w-} \\ I_p \end{bmatrix}, \tag{1a}$$

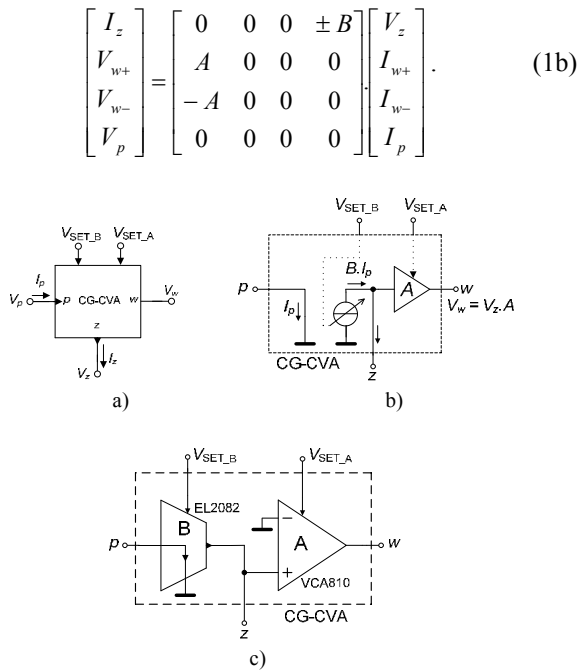

Fig. 4. Controlled gain current amplified voltage amplifier (CG-CVA): a) symbol, b) behavioral model, c) possible implementation.

General adjustable element can be created if adjustable voltage amplifier is used instead of voltage buffer (Fig. 4). It provides full control, i.e. current gain (B) and voltage gain (A). We called this element as controlled gain current and voltage amplifier (CG-CVA). Version with inverting current amplifier is called controlled gain inverted current and voltage amplifier (CG-ICVA). Possible modification with dual voltage output ($w+$, $w-$) could be called dual output controlled gain current and voltage amplifier (DO-CG-CVA). Ideal behavior is clear from (1b).

3. Proposed Oscillators

We have used well-know and popular method for synthesis and design of oscillators. Approach is based on lossless and lossy integrators in the loop. Approach using state variable methods [2], [58]-[61] could also be used for this synthesis and results are identical. Elementary circuit presented in Fig. 5 represents basic building block with transfer constant $I_z/V_i = B/R$. This building block with grounded capacitors at z ports is the main core of future applications (oscillators).

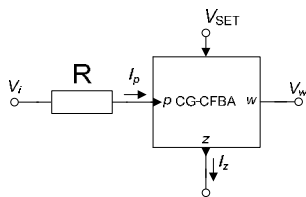

Fig. 5. Elementary building block.

The first designed circuit is shown in Fig. 6. It was created on the basis of discussed approach and elementary

building block from Fig. 5, with the following characteristic equation:

$$s^2 + \frac{-G_1 - G_2 - G_3 + G_3 B_2}{C_2} s + \frac{B_1 G_1 G_2}{C_1 C_2} = 0. \quad (2)$$

Condition of oscillation and oscillation frequency are:

$$B_2 = 1 + \frac{G_1 + G_2}{G_3}, \quad (3)$$

$$\omega_0 = \sqrt{\frac{B_1 G_1 G_2}{C_1 C_2}} \quad (4)$$

where adjustable current gain B_1 stands for current gain of the first active element (CG-CIBA) and B_2 represents current gain of the second active element (CG-CFBA).

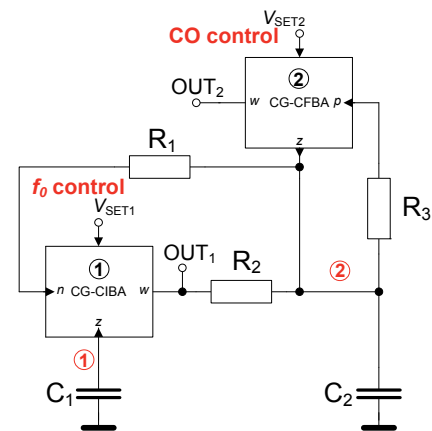

Fig. 6. The first proposed oscillator.

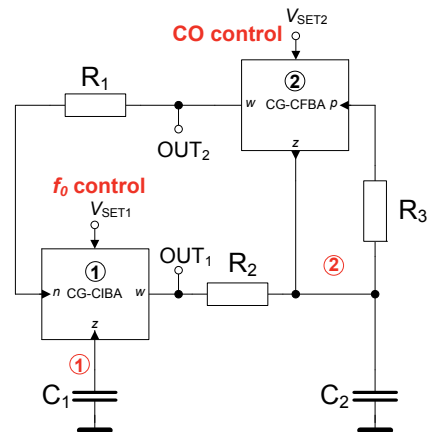

Fig. 7. The second version of the oscillator.

The second solution of the oscillator shown in Fig. 7 was derived from the circuit in Fig. 6 when the resistor R_1 is directly connected to the voltage output of the CG-CFBA. This modification of the oscillator has positive effect on the characteristic equation, which has now the following form:

$$s^2 + \frac{-G_2 - G_3 + G_3 B_2}{C_2} s + \frac{B_1 G_1 G_2}{C_1 C_2} = 0. \quad (5)$$

Oscillation frequency has the same form as in (4), but condition of oscillation is now:

$$B_2 = 1 + \frac{G_2}{G_3}. \tag{6}$$

As shown later, we suppose equality of passive elements for further simplification: $R_1 = R_2 = R$ and $C_1 = C_2 = C$. We used discussed simplifications and compared COs (3) and (6). Theoretical gains $B_2 = 3$ (Fig. 6) and $B_2 = 2$ (Fig. 7) are required to start the oscillations. Possibility of independent adjusting of f_0 and CO by B_1 or R_1 and B_2 is obvious. Control of f_0 by only one parameter (B_1) without another matching condition is advantageous. We are interested only in direct electronic control. Therefore, tuning by passive element is not appropriate for our approach. The oscillators also belong to SRCO types due to the controllability by R_1 . The ideal relative sensitivities of f_0 on circuit parameters are

$$S_{B_1}^{o_0} = -S_{R_1}^{o_0} = -S_{R_2}^{o_0} = -S_{C_1}^{o_0} = -S_{C_2}^{o_0} = 0.5, \tag{7}$$

$$S_{B_2}^{o_0} = S_{R_3}^{o_0} = 0. \tag{8}$$

The ratio between amplitude of state voltages v_1 and v_2 (therefore also between V_{OUT1} and V_{OUT2}) is

$$\frac{V_{OUT1}}{V_{OUT2}} = \frac{-B_1}{sR_1C_1} = \frac{-B_1}{j\omega R_1C_1}. \tag{9}$$

Substitution of the ω by ω_0 from (4) to (9) leads to

$$\frac{V_{OUT1}}{V_{OUT2}} = \frac{-B_1}{j\sqrt{\frac{B_1}{R_1R_2C_1C_2}}R_1C_1} = jB_1\sqrt{\frac{R_2C_2}{R_1C_1B_1}}. \tag{10}$$

It confirms the fact that both produced signals are in quadrature. If we suppose equality $R_1 = R_2 = R$ and $C_1 = C_2 = C$ then the relation between both voltages is given by

$$\frac{V_{OUT1}}{V_{OUT2}} = j\sqrt{B_1}, \tag{11}$$

therefore amplitude of V_{OUT1} is dependent on B_1 and in fact on adjusted f_0 . Produced signals have equal amplitudes for $B_1 = 1$. This problem is not often discussed and studied in detail, but it is usually presented in many hitherto published simple oscillator solutions (for example [18], [20]). Nonlinear dependence of f_0 on parameter B_1 (suitable for tuning) is next consequence.

We also proposed a solution where dependence of produced amplitudes on tuning process is eliminated and tuning characteristic is linear. However, necessity of matching of two gains is now important [40]. The third oscillator (Fig. 8) is described by the following characteristic equation:

$$s^2 + \frac{G_1 + G_3 - G_3A_2}{C_2}s + \frac{B_1B_2G_1G_2}{C_1C_2} = 0. \tag{12}$$

The CO and f_0 determined from (12) have forms:

$$A_2 = 1 + \frac{G_1}{G_3}, \quad \omega_0 = \sqrt{\frac{B_1B_2G_1G_2}{C_1C_2}}. \tag{13}, (14)$$

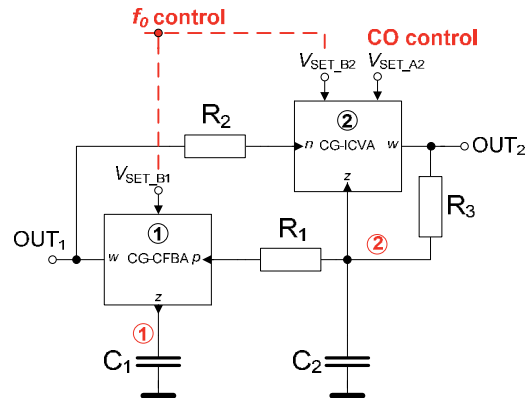

Fig. 8. The third version of oscillator with direct electronic adjusting.

The parameter A_2 is the voltage gain of the CG-ICVA in Fig. 8. For more details see principle in Fig. 4. Relation between produced amplitudes is

$$\frac{V_{OUT1}}{V_{OUT2}} = \frac{B_1}{sR_1C_1} = \frac{B_1}{j\omega R_1C_1}, \tag{15}$$

and after modification it leads to

$$\frac{V_{OUT1}}{V_{OUT2}} = \frac{B_1}{j\sqrt{\frac{B_1B_2}{R_1R_2C_1C_2}}R_1C_1} = -jB_1\sqrt{\frac{R_2C_2}{R_1C_1B_1B_2}}. \tag{16}$$

We suppose $B_1 = B_2 = B$ and therefore (16) simplifies to

$$\frac{V_{OUT1}}{V_{OUT2}} = -j\sqrt{\frac{R_2C_2}{R_1C_1}}. \tag{17}$$

We also suppose above discussed simplification of equality of passive elements ($R_1 = R_2 = R$ and $C_1 = C_2 = C$). Therefore output amplitudes are equal to each other even if f_0 is tuned.

The ideal relative sensitivities of f_0 in (14) on circuit parameters are very similar to the previous case:

$$S_{B_1}^{o_0} = S_{B_2}^{o_0} = -S_{R_1}^{o_0} = -S_{R_2}^{o_0} = -S_{C_1}^{o_0} = -S_{C_2}^{o_0} = 0.5, \tag{18}$$

$$S_{A_2}^{o_0} = S_{R_3}^{o_0} = 0. \tag{19}$$

Implementation of adjustable current gain is very favorable for direct electronically controllable applications, for example oscillators. For instance, both circuits in [37] allow tuning by changing the values of resistors only. For example, the second circuit in [37] does not allow tuning without changes of one amplitude as discussed by authors in [37]. Changing the value of only one resistor is suitable for f_0 tuning. However, this approach [40] allows to control f_0 similarly as it is shown in Fig. 8 (B_1 and B_2 for tuning of f_0). This control approach removes remaining drawback of the second circuit in [37].

4. Experiments and Real Behavior

The second solution of the oscillator (Fig. 7) was chosen as an example for experimental verification and detailed analysis. This selection is also caused by the reason that we would like to show some drawbacks of the second solution (dependence of amplitude on gain B in case of quadrature signals is documented).

Behavior of each circuit is affected by real features of active elements. Input resistance (port p or n) of both active elements is labeled as R_p or R_n . Output resistances R_w (at port w) are in most cases negligible because opamp (as voltage buffer) has values $< 1 \Omega$ in wide frequency range. Input capacitances of active elements have minimal impact because they are together with quite small resistance. Impedances of auxiliary port z consist of high resistive and capacitive part. High impedance node 1 and node 2 are influenced by output resistance of the used current amplifier and by input resistance of voltage buffer. We labeled this parameter as R_z . Capacitances in auxiliary port are labeled as C_z . Basic models of used active elements for non-ideal analysis are in Fig. 9.

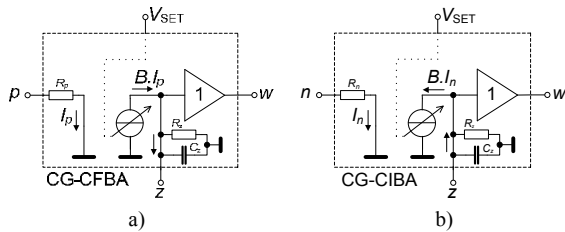

Fig. 9. Non-ideal models of used active elements.

CG-CIBA was built from four-quadrant current-mode multiplier EL4083 [62] (it allows both negative and positive current output). However, current gain adjusting is limited only to unity [62]. The second part (voltage buffer) was constructed by dual opamp LT1364 [63]. CG-CFBA was created from current-mode multiplier EL2082 [64] because it allows larger range of current gain. Opamp LT1364 was also used. In our case is $R_z \approx 830 \text{ k}\Omega$. Output impedances of EL4083 and EL2082 are approximately $1 \text{ M}\Omega / 5 \text{ pF}$ and input impedance of LT1364 is approximately $5 \text{ M}\Omega / 3 \text{ pF}$ [63]. Both parasitic capacitances have approximately values $C_z \approx 8 \text{ pF}$. Input resistance of inverting CG-CIBA (R_n) is dependent on auxiliary bias current and varies in range from 40 to 700 Ω if auxiliary bias current is changed from 2.5 mA to 0.2 mA. It was tested experimentally, because it is not discussed in [62]. Expected value of R_n is approximately 300 Ω in our case (it is quite high value). Input resistance of CG-CFBA has fixed and lower value, $R_p \approx 95 \Omega$.

Passive external elements of oscillator (Fig. 7) were selected as $R_1 = R_2 = R_3 = 1 \text{ k}\Omega$, $C_1 = C_2 = 100 \text{ pF}$ and parameters of active elements were designed as $B_1 = 1$, $B_2 = 2$, respectively. The model of oscillator in Fig. 10 takes into account also important parasitic elements placed

in critical parts of the circuit ($R_{z1} = R_{z2} = 830 \text{ k}\Omega$, $C_{z1} = C_{z2} = 8 \text{ pF}$).

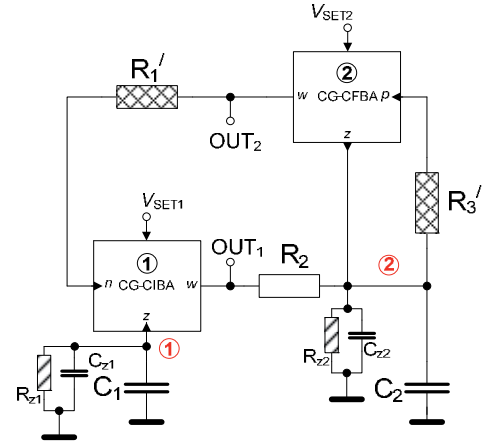

Fig. 10. Important parasitic influences in the circuit.

Real values of passive elements are $R_1' = R_1 + R_n \approx 1.3 \text{ k}\Omega$, $R_3' = R_3 + R_p \approx 1.1 \text{ k}\Omega$, $C_1' = C_1 + C_{z1} \approx 108 \text{ pF}$, $C_2' \approx 108 \text{ pF}$. CO and f_0 have now the following and more complex forms:

$$B_2 \geq \frac{R_1' R_{z1} R_{z2} C_1' (R_2 + R_3') + R_1' R_2 R_3' (R_{z1} C_1' + R_{z2} C_2')}{R_1' R_2 R_3' R_{z1} R_{z2} C_1'} \quad (20)$$

$$\omega_0' = \sqrt{\frac{R_3' R_{z2} (B_1 R_{z1} + R_1') + R_1' R_2 (R_{z2} - B_2 R_{z2} + R_3')}{R_1' R_2 R_3' R_{z1} R_{z2} C_1' C_2'}} \quad (21)$$

From (21) it is clear that B_2 could influence oscillation frequency. Nevertheless, impact of the second sum term in (21) is very small because it has several times lower value in comparison with the first term and B_2 has quite constant value (in comparison to B_1). Possible influence on exact value of f_0 appears for $B_1 < 0.1$ only. Tab. 1 provides comparison of the order of terms magnitude in nominator from (21).

B_1 [-]	$R_3' R_{z2} (B_1 R_{z1} + R_1')$	$R_1' R_2 (R_{z2} - B_2 R_{z2} + R_3')$
10	10^{15}	10^{12}
1	10^{14}	10^{12}
0.1	10^{13}	10^{12}
0.01	10^{12}	10^{12}

Tab. 1. Magnitude difference of members of (21).

Influences of imperfections of voltage followers were also found in f_0 . Modified equation (21), considering this problem is in form:

$$\omega_0' = \sqrt{\frac{R_3' R_{z2} (B_1 R_{z1} \alpha_1 \alpha_2 + R_1') + R_1' R_2 (R_{z2} - B_2 R_{z2} + R_3')}{R_1' R_2 R_3' R_{z1} R_{z2} C_1' C_2'}} \quad (22)$$

where α_1 and α_2 are non-ideal voltage gains. Practically, these gains are not equal to 1. Tab. 2 shows impact on non-accurate gain (buffering) on deviation $f_0 \pm \Delta f_0$ (worst case) based on calculation (22) for $f_0 = 1.293 \text{ MHz}$. Tolerances of these undesired gains (larger than 5%) could cause additional significant problems with accuracy of f_0 (Tab. 2).

Toler. $\alpha_{1,2}$ [%]	$\alpha_{1,2}$ [-]	$\pm\Delta f_0$ [kHz]
± 10	0.90-1.10	130
± 5	0.95-1.05	65
± 2	0.98-1.02	26

Tab. 2. Impact of non-accurate voltage buffering on f_0 .

The circuit was complemented by AGC system (Fig. 11) employing simple common-source transistor stage, which allows control of B_2 through V_{SET2} by rectified output signal. Common bipolar transistor BC547B and diode 1N4148 was used in AGC. Voltage V_h in ACG circuit is derived from voltage setting the CO and its value is between 2 - 2.5 V. Increasing of output level causes larger base-emitter voltage and causes decreasing of V_{SET2} (therefore also B_2). Decreasing of V_{OUT2} causes increasing of V_{SET2} . A very precise and careful setting is necessary for correct operation of AGC.

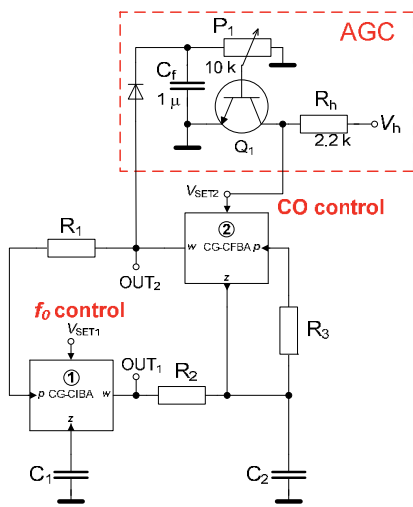
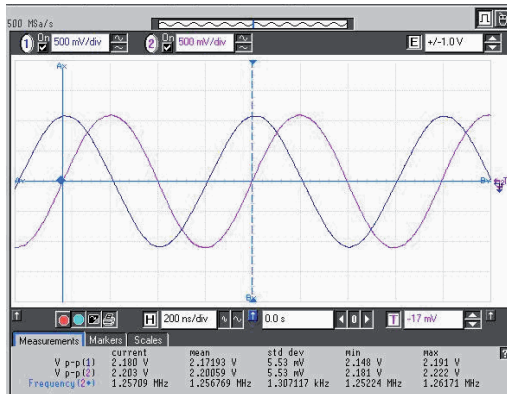
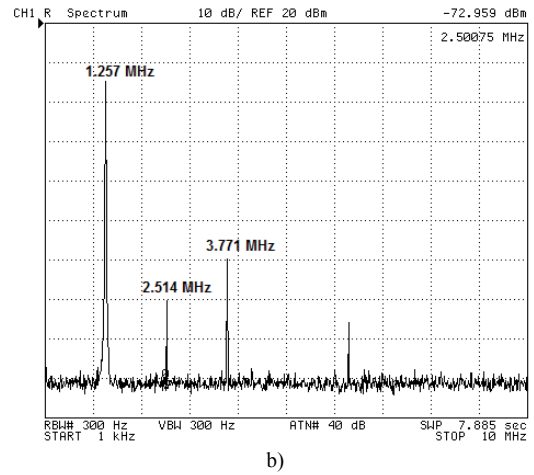

Fig. 11. Important parasitic influences in the circuit.

Results of experiments were obtained by oscilloscope Agilent Infinium 54820A and vector network/spectrum analyzer Agilent 4395A. Supply voltage was $V_{DD} = +5\text{ V}$ and $V_{SS} = -5\text{ V}$. Real active elements and their properties are considered. Expected oscillation frequency is $f_0 = 1.293\text{ MHz}$ (21) for selected and designed parameters (if $B_1 = 1$). Measured value was 1.257 MHz. Deviation is mostly caused by inaccuracy of expected value of R_{n1} . This parameter is also dependent on bias current [62]. Transient response and spectrum of V_{OUT2} are shown in Fig. 12.



a)



b)

Fig. 12. Measured results: a) transient responses, b) spectrum of V_{OUT2} .

Relation between control voltages and current gains are $B_1 \approx V_{SET1}/V_{DD}$ [62] and $B_2 \approx V_{SET2}$ [64]. Range of tunability was measured from 100 kHz to 1.257 MHz for B_1 changed from 0.01 to 1, see Fig. 13.

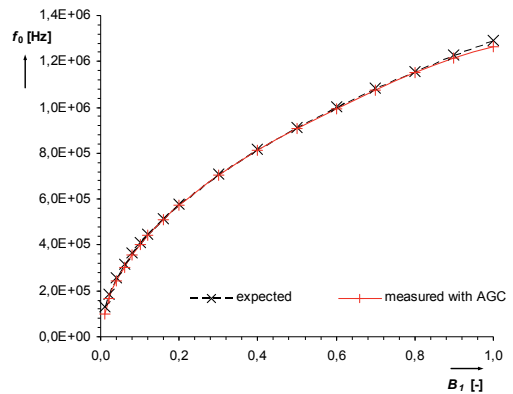
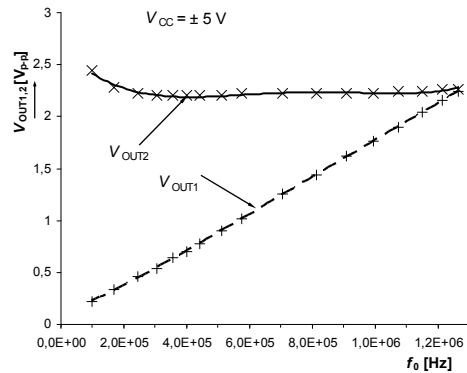

Fig. 13. Dependence of f_0 on current gain B_1 .

Output level (V_{OUT2}) has quite constant value $2.22 \pm 0.06\text{ V}_{p-p}$ in frequency range between 400 kHz and 1.257 MHz ($B_1 \in \{0.1; 1\}$), see Fig. 14 (a). Attenuation of higher harmonic components is greater than 40 dB (Fig. 12 (b)) and THD is in range from 0.6 to 1 % (Fig. 14 (b)). THD of V_{OUT1} is about 1 - 1.3 % in almost whole range of f_0 adjusting (Fig. 14 (b)). Output level of V_{OUT1} changes according to B_1 from 0.22 to 2.24 V, see Fig. 14 (a).



a)

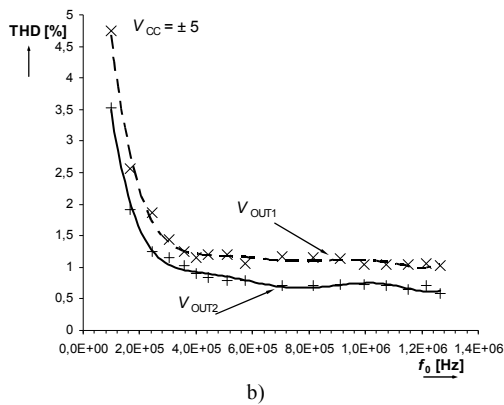

Fig. 14. Results of tuning process: a) dependence of output levels on controlled current gain B_1 , b) dependence of THD on oscillation frequency.

Dependence of V_{OUT1} on B_1 is depicted in Fig. 15. It confirms (11) very well. Measured prototype is shown in Fig. 16.

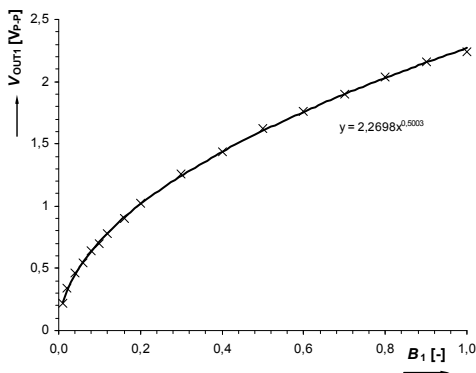

Fig. 15. Dependence of V_{OUT1} on B_1 .

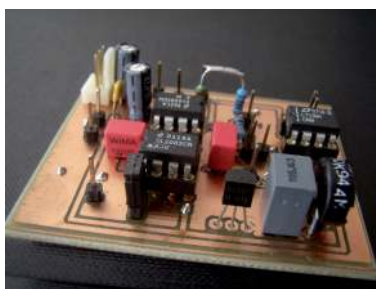

Fig. 16. Measured prototype.

5. Conclusion

The most important contributions of presented solutions are direct electronic and also independent control of CO and f_0 , suitable AGC circuit implementation, buffered low-impedance outputs, and of course, grounded capacitors. Independent tunability by only one parameter is very useful, but tuning characteristic is nonlinear. The most important drawback is dependence of amplitude V_{OUT1} on current gain B_1 (if quadrature outputs are required), which was confirmed by experimental measurements. Circuit in Fig. 7 was selected in order to show all features and docu-

ment the expected behavior, which was first derived theoretically (equations). It is quite hidden problem at first sight without precise analyses. This problem was solved and possible conception (Fig. 8) was introduced. It is necessary to change oscillation frequency simultaneously by two parameters (adjustable current gains) and oscillation condition by adjustable voltage gain (all in frame of two active elements). Equality (and invariability) of generated amplitudes and linearity of tuning characteristic during the tuning process are required aspects. This feature is not novel advantage of circuit in Fig. 8. Detailed discussion is available in [40] for example. All favorable features were obtained without further extension of proposed circuit. Future work will be focused on detailed tests of proposed circuit in Fig. 8. However, controllability of f_0 by one parameter (Fig. 8) was lost and simultaneous change of two parameters is necessary [40].

Acknowledgements

The research leading to these results has received funding from the European Community's Seventh Framework Programme (FP7/2007-2013) under grant agreement no. 230126. The research described in the paper was also supported by the Czech Science Foundation projects under No. 102/11/P489 and No. 102/09/1681. The research described in the paper is a part of the COST Action IC0803 RF/Microwave communication subsystems for emerging wireless technologies, financed by the Czech Ministry of Education by the grant no. OC09016. The support of the project CZ.1.07/2.3.00/20.0007 WICOMT, financed from the operational program Education for Competitiveness, is gratefully acknowledged. The described research was performed in laboratories supported by the SIX project; the registration number CZ.1.05/2.1.00/03.0072, the operational program Research and Development for Innovation. Authors wish to thank the anonymous reviewers for their useful and constructive comments that helped to improve the paper. Authors are also thankful to Dr. Jaroslav Koton from the Brno University of Technology, Czech Republic, for his comments and corrections made on the paper.

References

- [1] BIOLEK, D., SENANI, R., BIOLKOVA, V., KOLKA, Z. Active elements for analog signal processing: Classification, review, and new proposal. *Radioengineering*, 2008, vol. 17, no. 4, p. 15 – 32.
- [2] GUPTA, S. S., SHARMA, R. K., BHASKAR, D. R., SENANI, R. Sinusoidal oscillators with explicit current output employing current-feedback op-amps. *International Journal of Circuit Theory and Applications*, 2010, vol. 38, no. 2, p. 131-147.
- [3] GUPTA, S. S., BHASKAR, D. R., SENANI, R. New voltage controlled oscillators using CFOAs. *AEU – International Journal of Electronics and Communications*, 2009, vol. 63, no. 3, p. 209-217.
- [4] MARTINEZ, P. A., SABADELL, J., ALDEA, C. Grounded resistor controlled sinusoidal oscillator using CFOAs. *Electronics Letters*, 1997, vol. 33, no. 5, p. 346-348.

- [5] MAHESHWARI, S., CHATUVERDI, B. High output impedance CMQOs using DVCCs and grounded components. *International Journal of Circuit Theory and Applications*, 2011, vol. 39, no. 4, p. 427-435.
- [6] HERENC SAR, N., VRBA, K., KOTON, J., LAHIRI, A. Realizations of single-resistance-controlled quadrature oscillators using a generalized current follower transconductance amplifier and a unity gain voltage-follower. *Int. Journal of Electronics*, 2010, vol. 97, no. 8, p. 879-906.
- [7] SIRIPRUCHYANUN, M., CHANAPROMMA, C., SILAPAN, P., JAIKLA, W. BiCMOS Current-Controlled Current Feedback Amplifier (CC-CFA) and its applications. *WSEAS Transactions on Electronics*, 2008, vol. 6, no. 5, p. 203-219.
- [8] HORNG, J. W. A sinusoidal oscillator using current-controlled current conveyors. *Int. Journal of Electronics*, 2001, vol. 88, no. 6, p. 659-664.
- [9] GEIGER, R. L., SANCHEZ-SINENCIO, E. Active filter design using operational transconductance amplifiers: a tutorial. *IEEE Circuits and Devices Magazine*, 1985, vol. 1, p. 20-32.
- [10] LAHIRI, A. Explicit-current-output quadrature oscillator using second-generation current conveyor transconductance amplifier. *Radioengineering*, 2009, vol. 18, no. 4, p. 522-526.
- [11] SOTNER, R., JERABEK, J., PETRZELA, J., DOSTAL, T., VRBA, K. Electronically tunable simple oscillator based on single-output and multiple output transconductor. *IEICE Electron. Express*, 2009, vol. 6, no. 20, p. 1476-1482.
- [12] SURAKAMPONTORN, W., THITIMAJSHIMA, W. Integrable electronically tunable current conveyors. *IEE Proceedings-G*, 1988, vol. 135, no. 2, p. 71-77.
- [13] FABRE, A., MIMECHE, N. Class A/AB second-generation current conveyor with controlled current gain. *Electronics Letters*, 1994, vol. 30, p. 1267-1268.
- [14] MINAEI, S., SAYIN, O. K., KUNTMAN, H. A new CMOS electronically tunable current conveyor and its application to current-mode filters. *IEEE Transaction on Circuits and Systems I - Regular papers*, 2006, vol. 53, no. 7, p. 1448-1457.
- [15] TANGSRIRAT, W. Electronically tunable multi-terminal floating nullor and its application. *Radioengineering*, 2008, vol. 17, no. 4, p. 3-7.
- [16] SHI-XIANG, S., GUO-PING, Y., HUA, C. A new CMOS electronically tunable current conveyor based on translinear circuits. In *Proc. of 7th Int. Conf. on ASIC (ASICON 2007)*, 2007, p. 569-572.
- [17] SOTNER, R., HRUBOS, Z., SLEZAK, J., DOSTAL, T. Simply adjustable sinusoidal oscillator based on negative three-port current conveyors. *Radioengineering*, 2010, vol. 19, no. 3, p. 446 to 453.
- [18] SOTNER, R., JERABEK, J., PROKOP, R., VRBA, K. Current gain controlled CCTA and its application in quadrature oscillator and direct frequency modulator. *Radioengineering*, 2011, vol. 20, no. 1, p. 317-326.
- [19] KUMNGERN, M., CHANWUTIUM, J., DEJHAN, K. Electronically tunable multiphase sinusoidal oscillator using translinear current conveyors. *Analog Integrated Circuits and Signal Processing*, 2010, vol. 65, no. 2, p. 327-334.
- [20] HERENC SAR, N., LAHIRI, A., VRBA, K., KOTON, J. An electronically tunable current-mode quadrature oscillator using PCAs. *Int. Journal of Electronics*, 2011, available online, DOI: 10.1080/00207217.2011.643489.
- [21] BIOLKOVA, V., BIOLEK, D. Shadow filters for orthogonal modification of characteristic frequency and bandwidth. *Electronics Letters*, 2010, vol. 46, no. 12, p. 830-831.
- [22] LAKYS, Y., FABRE, A. Shadow filters - new family of second-order filters. *Electronics Letters*, 2010, vol. 46, no. 4, p. 276-277.
- [23] TANGSRIRAT, W., PUKKALANUN, T. Digitally programmable current follower and its applications. *AEU - International Journal of Electronics and Communications*, 2009, vol. 63, no. 5, p. 416 to 422.
- [24] PSYCHALINOS, C., SPANIDOU, A. Current amplifier based grounded and floating inductance simulators. *AEU - International Journal of Electronics and Communications*, 2006, vol. 60, no. 2, p. 168-171.
- [25] SEDIGHI, B., BAKHTIAR, M. S. Variable gain current mirror for high-speed applications. *IEICE Electronics Express*, 2007, vol. 4, no. 8, p. 277-281.
- [26] JERABEK, J., VRBA, K. Fully differential universal filter with differential and adjustable current followers and transconductance amplifiers. In *Proc. of the 33rd Int. Conf. on Telecommunications and Signal Processing - TSP 2010*. Baden (Austria), 2010, p. 5-9.
- [27] JERABEK, J., SOTNER, R., VRBA, K. Fully-differential current amplifier and its application to universal and adjustable filter. In *International Conference on Applied Electronics APPEL 2010*. Plzeň (Czech Republic), 2010, p. 141-144.
- [28] KOTON, J., VRBA, K., HERENC SAR, N. Tuneable filter using voltage conveyors and current active elements. *Int. J. Electronics*, 2009, vol. 96, no. 8, p. 787-794.
- [29] BIOLEK, D., BAJER, J., BIOLKOVA, V., KOLKA, Z., KUBICEK, M. Z copy-controlled gain-current differencing buffered amplifier and its applications. *International Journal of Circuit Theory and Applications*, 2011, vol. 39, no. 3, p. 257-274.
- [30] MAHMOUD, S., HASHIES, M., SOLIMAN, A. Low-voltage digitally controlled fully differential current conveyor. *IEEE Transactions on Circuits and Systems I*, 2005, vol. 52, no. 10, p. 2055-2064.
- [31] CHEN, J. J., CHEN, C. C., TSAO, H. W., LIU, S. I. Current-mode oscillators using single current follower. *Electronics Letters*, 1991, vol. 27, no. 22, p. 2056-2059.
- [32] ABUELMA'ATTI, M. T. Grounded capacitor current-mode oscillator using single current follower. *IEEE Transaction on Circuits and Systems I: Fundamental Theory and Applications*, 1992, vol. 39, no. 12, p. 1018-1020.
- [33] SOLIMAN, A. M. Novel oscillators using current and voltage followers. *Journal of the Franklin Institute*, 1998, vol. 335, no. 6, p. 997-1007.
- [34] GUPTA, S. S., SENANI, R. New single-resistance-controlled oscillator configurations using unity-gain cells. *Analog Integrated Circuits and Signal Processing*, 2006, vol. 46, no. 2, p. 111-119.
- [35] GUPTA, S. S., SENANI, R. New single resistance controlled oscillators employing a reduced number of unity-gain cells. *IEICE Electron. Express*, 2004, vol. 1, no. 16, p. 507-512.
- [36] MARTINEZ, P. A., MONGE-SANZ, B. M. Single resistance controlled oscillator using unity gain cells. *Microelectronics Reliability*, 2005, vol. 45, no. 1, p. 191-194.
- [37] BIOLKOVA, V., BAJER, J., BIOLEK, D. Four-phase oscillators employing two active elements. *Radioengineering*, 2011, vol. 20, no. 1, p. 334-339.
- [38] SOULIOTIS, G., PSYCHALINOS, C. Electronically controlled multiphase sinusoidal oscillators using current amplifiers. *International Journal of Circuit Theory and Applications*, 2009, vol. 37, no. 1, p. 43-52.
- [39] KUMNGERN, M., JUNNAPIYA, S. A sinusoidal oscillator using translinear current conveyors. In *Asia Pacific Conference on Circuits and Systems (APPCAS 2010)*, 2010, p. 740-743.

- [40] BIOLEK, D., LAHIRI, A., JAIKLA, W., SIRIPRUCHYANUN, M., BAJER, J. Realisation of electronically tunable voltage-mode/current-mode quadrature sinusoidal oscillator using ZC-CG-CDBA. *Microelectronics Journal*, 2011, vol. 42, no. 10, p. 1116 to 1123.
- [41] BAJER, J., BIOLEK, D. Digitally controlled quadrature oscillator employing two ZC-CG-CDBAs. In *Proc. of International Conference on Electronic Devices and Systems EDS'09 IMAPS CS*. Brno (Czech Republic), 2009, p. 298-303.
- [42] BIOLEK, D., BIOLKOVA, V. Implementation of active elements for analog signal processing by diamond transistors. In *Proc. of International Conference on Electronic Devices and Systems EDS'09 IMAPS CS*. Brno (Czech Republic), 2009, p. 304-309.
- [43] *OPA860: Wide Bandwidth Operational Transconductance Amplifier and Buffer*, Texas Instruments. [Online]. 2005, last modified 8/2008 [Cited 2011-07-28]. Available at URL: <<http://focus.ti.com/lit/ds/symlink/opa860.pdf>>
- [44] KUNTMAN, H., OZPINAR, A. On the realization of DO-OTA-C oscillators. *Microelectronics Journal*, 1998, vol. 29, no. 12, p. 991 to 997.
- [45] RODRIGUEZ-VAZQUEZ, A., LINAREZ-BARRANCO, B., HUERTAS, L., SANCHEZ-SINENCIO, E. On the design of voltage-controlled sinusoidal oscillators using OTA's. *IEEE Transactions on Circuits and Systems*, 1990, vol. 37, no. 2, p. 198-211.
- [46] SWAMY, M., RAUT, R., TANG, Z. Generation of OTA-C oscillator structures using network transposition. In *Proceedings of 47th IEEE International Midwest Symposium on Circuits and Systems*. Hiroshima (Japan), 2004, p. 73-76.
- [47] LINAREZ-BARRANCO, B., SERANO-GARARREDONA, T., RAMOS-MARTOS, J., CEBALLOS-CACERES, J., MORA, J., LINAREZ-BARRANCO, A. A precise 90 quadrature OTA-C oscillator tunable in the 50-130 MHz range. *IEEE Transactions on Circuits and Systems I: Regular papers*, 2004, vol. 51, no. 4, p. 649-663.
- [48] CAM, U., KUNTMAN, H., ACAR, C. On the realization of OTA-C oscillators. *International Journal of Electronics*, 1998, vol. 85, no. 3, p. 313-326.
- [49] SINGH, V. Equivalent forms of dual-OTA RC oscillators with application to grounded-capacitor oscillators. *IEE Proc - Circuits Devices Systems*, 2006, vol. 153, no. 2, p. 95-99.
- [50] LINAREZ-BARRANCO, B., RODRIGUEZ-VAZQUEZ, A., SANCHEZ-SINENCIO, E., HUERTAS, L., J. CMOS OTA-C high frequency sinusoidal oscillators. *IEEE Journal of Solid-State Circuits*, 1991, vol. 26, no. 2, p. 160-165.
- [51] SOLIMAN, A. M. CMOS balanced output transconductor and applications for analog VLSI. *Microelectronics Journal*, 1999, vol. 30, no. 1, p. 29-39.
- [52] TAO, Y., FIDLER, J. K. Electronically tunable dual-OTA second-order sinusoidal oscillators/filters with non-interacting controls: A systematic synthesis approach. *IEEE Transaction on Circuits and Systems I: Fundamental Theory and Applications*, 2000, vol. 47, no. 2, p. 117-129.
- [53] PROMEE, P., ANGKEAW, K., CHANWUTIUM, J., DEJHAN, K. Dual input all-pass networks using MO-OTA and its application. In *ECTI-CON Conference*, 2007, p. 129-132.
- [54] GALAN, J., CARVALAJ, R. G., TORRALBA, A., MUNOZ, F., RAMIREZ-ANGULO, J. A low-power low-voltage OTA-C sinusoidal oscillator with large tuning range. *IEEE Transaction on Circuits and Systems I: Fundamental Theory and Applications*, 2005, vol. 52, no. 2, p. 283-291.
- [55] BHASKAR, D. R., ABDALLA, K. K., SENANI, R. Electronically-controlled current-mode second order sinusoidal oscillators using MO-OTAs and grounded capacitors. *Circuits and Systems*, 2011, vol. 2, no. 2, p. 65-73.
- [56] BHASKAR, D. R., SENANI, R. New CFOA-based single-element-controlled sinusoidal oscillators. *IEEE Transaction on Instrumentation and Measurement*, 2006, vol. 55, no. 6, p. 2014 to 2021.
- [57] SENANI, R., SINGH, V. K. Novel single-resistance-controlled-oscillator configuration using current feedback Amplifiers. *IEEE Transactions on Circuits and Systems - I: Fundamental Theory and Applications*, 1996, vol. 43, no. 8, p. 698-700.
- [58] SENANI, R., GUPTA, S. S. Synthesis of single-resistance-controlled oscillators using CFOAs: simple state-variable approach. *IEE Proceedings on Circuits Devices and Systems*, 1997, vol. 144, no. 2, p. 104-106.
- [59] GUPTA, S. S., SENANI, R. State variable synthesis of single resistance controlled grounded capacitor oscillators using only two CFOAs. *IEE Proceedings on Circuits, Devices and Systems*, 1998, vol. 145, no. 2, p. 135-138.
- [60] GUPTA, S. S., SENANI, R. State variable synthesis of single-resistance-controlled grounded capacitor oscillators using only two CFOAs: additional new realisations. *IEE Proceedings on Circuits Devices and Systems*, 1998, vol. 145, no. 6, p. 415-418.
- [61] PETRZELA, J., VYSKOCIL, P., PROKOPEC, J. Fundamental oscillators based on diamond transistors. In *Proceedings of 20th International Conference Radioelektronika 2010*. Brno (Czech Republic), 2010, p. 217-220.
- [62] *EL4083: Current-Mode Four-Quadrant Multiplier*, Intersil (Elantec) [Online]. 1995, last modified 2003 [Cited 2011-07-28]. Available at: <http://www.intersil.com/data/fn/fn7157.pdf>>
- [63] *LT1364: Dual and Quad 70 MHz, 1000 V/ μ s, Op Amps*, Linear Technology [Online]. 1994 [Cited 2011-07-28]. Available at URL: <<http://cds.linear.com/docs/Datasheet/13645fa.pdf>>
- [64] *EL2082: Current-Mode Multiplier*, Intersil (Elantec) [Online]. 1996, last modified 2003 [Cited 2011-07-28]. Available at URL: <<http://www.intersil.com/data/fn/fn7152.pdf>>
- [65] *AD8138: Low Distortion Differential ADC Driver*, Analog Devices [Online]. Last modified 1/2006 [Cited 2011-07-28]. Available at: <http://www.analog.com/static/imported-files/data_sheets/AD8138.pdf>
- [66] *VC4810: High Gain Adjust Range, Wideband, Variable Gain Amplifier*, Texas Instruments [Online]. 2003, last modified 12/2010 [Cited 2011-07-28]. Available at URL: <http://focus.ti.com/lit/ds/sbos275f/sbos275f.pdf>>

About Authors ...

Roman SOTNER was born in Znojmo, Czech Republic, in 1983. He received his M.Sc. and Ph.D. degrees from Brno University of Technology, Czech Republic, in 2008 and 2012, respectively. Currently, he is a technical worker at the Department of Radio Electronics, Faculty of Electrical Engineering and Communication, Brno University of Technology, Brno, Czech Republic. His interests are analog circuits (active filters, oscillators, audio, etc.), circuits in the current mode, circuits with direct electronic controlling possibilities especially and computer simulation.

Jan JERABEK was born in Bruntal, Czech Republic, in 1982. He received his Ph.D. degree in Electrical Engineering in 2011 from Brno University of Technology, Czech Republic. He received M.Sc. and B.Sc. degree from the same university in 2007 and in 2005, respectively. He is currently an assistant professor at the Department of

Telecommunications, Faculty of Electrical Engineering and Communication, Brno University of Technology. His research interests are focused on circuit applications of modern active elements such as current amplifiers and multiple output current followers. Dr. Jerabek is a member of IEEE.

Norbert HERENC SAR received his M.Sc. and Ph.D. degrees in Electronics & Communication and Teleinformatics from Brno University of Technology, Czech Republic, in 2006 and 2010, respectively. Currently, he is an Assistant Professor at the Department of Telecommunications, Faculty of Electrical Engineering and Communication, Brno University of Technology, Brno, Czech Republic. From September 2009 through February 2010 he was an Erasmus Exchange Student with the Department of Electrical and Electronic Engineering, Bogazici University, Istanbul, Turkey. His research interests include analog filters, current-mode circuits, tunable frequency filter design methods, and oscillators. He is an author or co-author of about 75 research articles published in international journals or conference proceedings. Dr. Herencsar is Senior Member of the IACSIT and Member of the IAENG and ACEEE.

Zdenek HRUBOS was born in Uherske Hradiste, Czech Republic, in 1984. He received his M.Sc. degree in 2009 from Brno University of Technology, Czech Republic. He is currently studying his Ph.D. study at the same university. His research interest is in computer analysis and synthesis of electronics circuits and nonlinear systems.

Tomas DOSTAL (*1943) received his Ph.D. degree in 1976 and DrSc. degree in 1989. He was with the University of Defense Brno (1976-1978 and 1980-1984), with the Military Technical College Baghdad (1978-1980), with the Brno University of Technology (1984-2008) and with the European Polytechnic Institute, Kunovice, Czech Republic (2008 - 2009). Since 2009 he has been with the College of Polytechnics, Jihlava as Professor of Electronics. His interests are in circuit theory, analog filters, switched capacitor networks and circuits in the current mode.

Kamil VRBA received his Ph.D. degree in Electrical Engineering in 1976, and the Prof. degree in 1997, both from the Technical University of Brno. Since 1990 he has been Head of the Department of Telecommunications, Faculty of Electrical Engineering and Computer Science, Brno University of Technology, Brno, Czech Republic. His research work is concentrated on problems concerned with accuracy of analog circuits and mutual conversion of analog and digital signals. In cooperation with AMI Semiconductor Czech, Ltd. (now ON Semiconductor Czech Republic, Ltd.) he has developed number of novel active function blocks for analog signal processing such as universal current conveyor (UCC), universal voltage conveyor (UVC), programmable current amplifier (PCA), digitally adjustable current amplifier (DACA), and others. He is an author or co-author of more than 700 research articles published in international journals or conference proceedings. Professor Vrba is a Member of IEEE and IEICE.