

Received June 7, 2020, accepted June 22, 2020, date of publication June 30, 2020, date of current version July 9, 2020.

Digital Object Identifier 10.1109/ACCESS.2020.3005948

Substrate Integrated Waveguide Filtenna With Two Controllable Radiation Nulls

CHUANYUN WANG^{1,2}, (Student Member, IEEE), XIN WANG^{1,2},
HAIWEN LIU¹, (Senior Member, IEEE), ZHIJIAO CHEN³, (Member, IEEE),
AND ZHIWEN HAN²

¹School of Information and Communications Engineering, Xi'an Jiaotong University, Xi'an 710049, China

²School of Information Engineering, East China Jiaotong University, Nanchang 330013, China

³School of Electronic Engineering, Beijing University of Posts and Telecommunications, Beijing 100876, China

Corresponding author: Haiwen Liu (haiwen_liu@hotmail.com)

This work was supported in part by the National Science Foundation of China under Grant U1831201 and Grant 61461020, in part by the Natural Science Foundation of Jiangxi Province under Grant 2017ACB20019, and in part by the Research Program of Jiangxi Province under Grant 2016BCB18010, Grant 20171BBE50056, and Grant 20181BCB24010.

ABSTRACT In this paper, a novel substrate integrated waveguide (SIW) filtenna with two controllable radiation nulls is proposed, which has the advantage of good radiation characteristics. Radiation nulls are generated by electric and magnetic mixed coupling structure and fundamental mode, respectively. And a quasi-elliptic characteristic can be obtained at the boresight gain direction. By changing the length of perturbation slot and the strength of electric coupling and magnetic coupling, the position of radiation nulls can be controlled independently. Compared to conventional filtenna, the proposed SIW filtenna has no extra filtering circuit to increase the dimension and complexity. Two resonant modes in the passband can be excited through loading electric and magnetic mixed coupling structure in one SIW cavity. The measured results are in good agreement with simulated results. The good frequency selectivity and out-of-band rejection are achieved. The proposed antenna exhibits a maximum realized gain of 5.8 dBi at the operating bandwidth. The measured impedance bandwidth is from 9.44 GHz to 9.68 GHz and the cross-polarization levels are lower than -20 dB in both planes.

INDEX TERMS Substrate integrated waveguide (SIW) antenna, filtenna, electric and magnetic mixed coupling.

I. INTRODUCTION

With the development of substrate integrated waveguide (SIW) technology owning some advantages such as low profile, easy integration and so on, SIW has been studied by lots of experts in microwave and millimeter wave communication systems [1], [2]. SIW has good radiation performance and gain characteristics, and is easily integrated to planar circuit [3]. Therefore, SIW is widely used to design antennas, filters, and other RF components [4]–[6].

Filtenna is a good method to significantly reduce the size of the RF front-end of communication systems. A lot of filtennas using SIW technology have been investigated and proposed [7]–[15]. [7] proposed a filter antenna using a common cavity cascaded to radiation element. A single-layered SIW filtenna with parasitic patch was proposed in [8]. Parasitic

patch and two pairs shoring posts are utilized for generating two radiation nulls. A low-profile duplexing SIW antenna based on common radiating cavity with filtering response was proposed [9]. Millimeter-wave filtering antenna using SIW filtering power divider was reported [10]. However, the designs in [7]–[10] make antennas bulky with precious filtering circuit footprints. [11] proposed a third-order SIW filtering antenna, cross coupling is introduced to generate a controllable radiation null and filtering response is achieved in gain curve. [12] proposed a single-layered SIW filtering antenna, a radiation null is obtained by placing the slot in the position where E-field is null. By changing the size of radiation slot, the position of radiation null can be controlled. A SIW filtering antenna was presented with one controllable radiation null using source-load coupling [13]. However, in previous work, only controllable one radiation null is generated in the either upper or lower stopband. In [14], two slots are etched on the top and bottom surfaces of SIW

The associate editor coordinating the review of this manuscript and approving it for publication was Santi C. Pavone.

cavity, respectively, not only achieving bidirectional radiation performance but also generating two radiation nulls. [15] proposed a dual-layer SIW cavity filtering antenna. Three modes (i.e. TE_{210} mode, TE_{010} mode and TE_{110} mode) are excited to achieve a radiation band and two radiation nulls. However, the controllable radiation null is not realized in [14] and [15].

In this letter, a substrate integrated waveguide filtenna with two controllable radiation nulls is proposed. The two resonant modes (i.e. a hybrid mode [16] and TE_{120} mode) are excited in a single passband. In addition, two radiation nulls can be obtained, generating a quasi-elliptic filtering response in gain curve. By using electric and magnetic mixed coupling structure, a radiation null can be introduced. Another radiation null is obtained by fundamental mode resonating in the SIW cavity. Two radiation nulls can be controlled by changing the strength of electric and magnetic mixed coupling and the length of perturbation slot, respectively. Measured results verify these characteristics. The proposed filtenna presents a high selectivity at the frequency bands can be easily adjusted to accomplish practical applications, for instance, in satellite communications and radar systems.

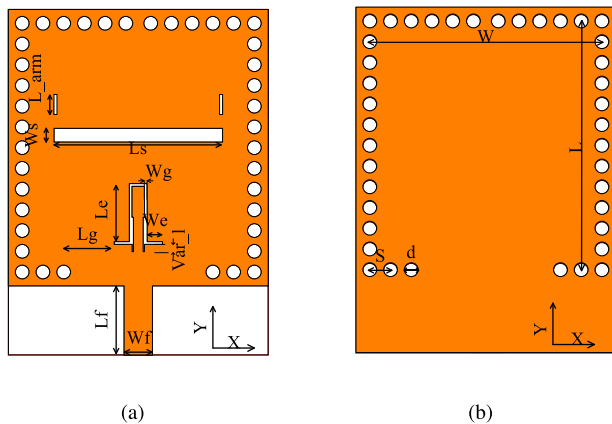

FIGURE 1. Configuration of the proposed antenna. (a) top view (b) bottom view. All dimensions in mm: $W = 16.8\text{mm}$, $L = 18\text{mm}$, $s = 1.5\text{mm}$, $d = 1\text{mm}$, $Wf = 2.05\text{mm}$, $Lf = 5\text{mm}$, $Ls = 12.2\text{mm}$, $Ws = 1\text{mm}$, $Lg = 3.65\text{mm}$, $Le = 4.2\text{mm}$, $We = 1.1\text{mm}$, $Wg = 0.2\text{mm}$, $var_l = 0.53\text{mm}$, $L_arm = 1\text{mm}$.

II. DESIGN OF THE ANTENNA

The configuration of proposed SIW filtenna is shown in Fig.1. It is printed on the Rogers RT/Duroid 5880 substrate with 0.5 mm. The relative dielectric constant and loss tangent are 2.2 and 0.0015, respectively. It consists of a SIW cavity and electric and magnetic mixed coupling structure, a transverse slot as radiation element is located in the center of resonant cavity. The antenna is excited by a $50\ \Omega$ stripline. In order to avoid energy leakage from side wall, the diameter of shorting-vias (d) and distance of shorting-vias (s) are designed, maintaining the conditions $d/s > 0.5$ and $d/\lambda_0 < 0.1$. λ_0 is the wave-length of the operating frequency in the freespace. And the dimension of SIW cavity can be obtained by (1) [17].

$$w_e = w - 1.08 \frac{d^2}{x} + 0.1 \frac{d^2}{w} \quad (1)$$

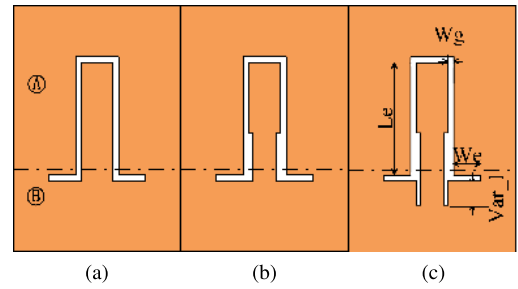

FIGURE 2. The structure of electric and magnetic mixed coupling. (a) Structure-I (b) Structure-II (c) Structure-III.

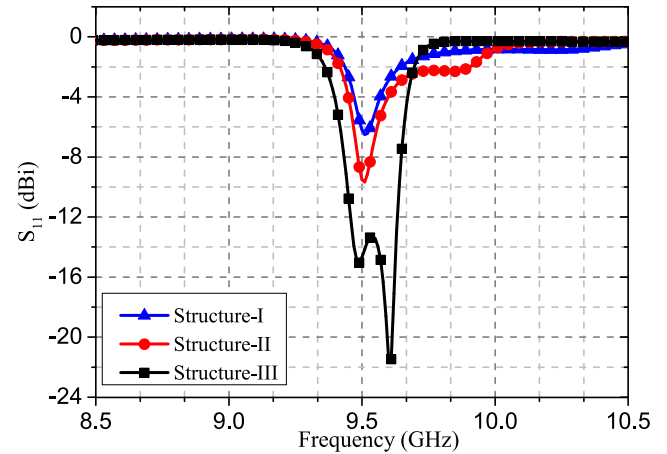

FIGURE 3. Frequency response of coupling structure.

where w is the width of SIW cavity, w_e is the width of equivalent rectangular waveguide.

A. EFFECT OF LOADING ELECTRIC AND MAGNETIC MIXED COUPLING STRUCTURE

In order to excite resonant mode and radiation null successfully, the electric and magnetic mixed coupling structure is introduced. As shown in Fig.2, three coupling structures are given: (a) original coupling structure; (b) the stepped impedance coupling structure; (c) the proposed coupling structure. The corresponding reflection coefficient and input impedance are shown Fig.3 and Fig.4, respectively. Loading structure-I, only one resonant mode is excited. In order to excite two resonant modes, structure-II is used. Impedance matching can be realized by using step-impedance transmission-line, and then the second resonant mode can be excited successfully. However, in the area A, using multistep-impedance transmission-line does not realize better impedance match. In order to reduce complexity of designing and get better impedance match, structure-III is proposed. In the area B, slot-stub Var_l is introduced. The length of step-impedance transmission-line by varying slot-stub Var_l improves the matching characteristics.

B. RESONANT MODE

TE_{120} mode is excited to generate one resonance successfully. The H-field distribution of TE_{120} mode is given in Fig.5(a).

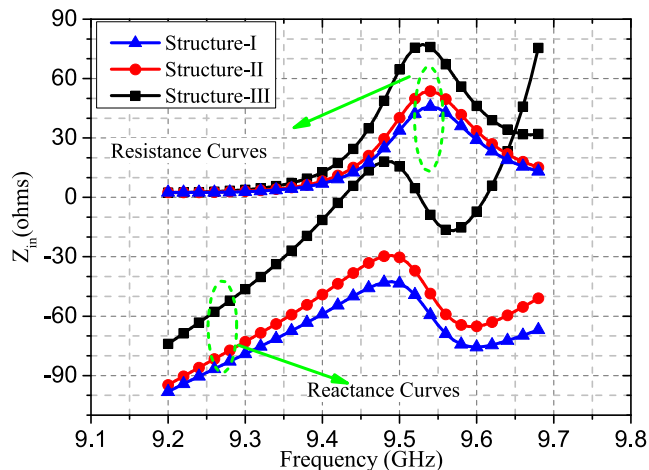

FIGURE 4. Input impedance of coupling structure.

The H-field on the both sides of the slot is opposite, and there is transverse field across the slot to generate radiation into the space. Loading electric and magnetic mixed coupling structure weaken the strength of TE_{120} , which leads to unequal magnitude of TE_{120} on the two sides of slot. In addition, fundamental mode and TE_{120} mode interact with each other, which generates a hybrid mode. The H-field distribution of the hybrid mode is shown in Fig.5(b). It can be seen that dominant H-field is concentrated on the right half cavity of radiation slot. The H-field of TE_{120} mode and fundamental mode cancel out each other to make H-field weak in the left half cavity of slot to generate a hybrid mode. Different magnitude of H-field at two sides of slot can generate radiation through the slot.

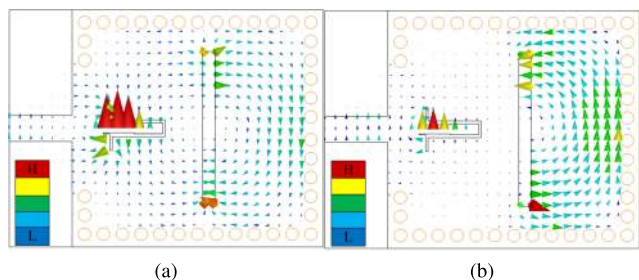

FIGURE 5. The distribution of H-field. (b) TE_{120} mode (a) hybrid mode.

C. RADIATION NULLS

Two radiation nulls locating on both sides of passband are generated due to electric and magnetic mixed coupling and fundamental mode.

The radiation null ($RN1$) at lower stopband is introduced by the resonance of fundamental mode. The slot is etched in the center of the resonating cavity. When fundamental mode is resonating, the current in the both sides of the slot is equal magnitude and in opposite. There is no existing across current in the slot and no broadside radiation is generated. Since the frequency of fundamental mode is determined by the dimension of cavity, in order to realize the controllability of $RN1$, perturbation slot L_{arm} is introduced. By changing the length

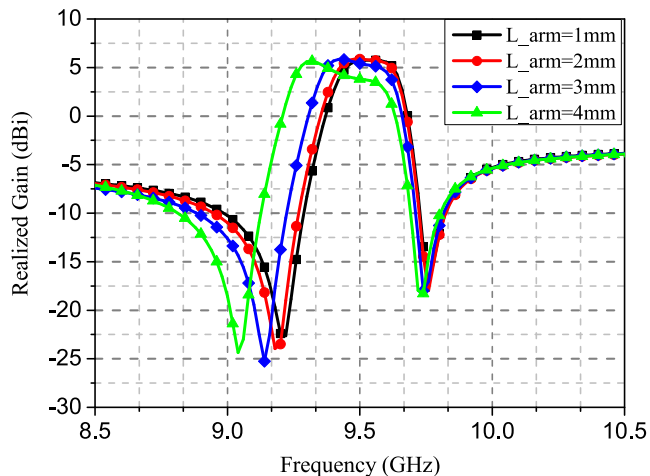

FIGURE 6. Position of $RN1$ with changing L_{arm} .

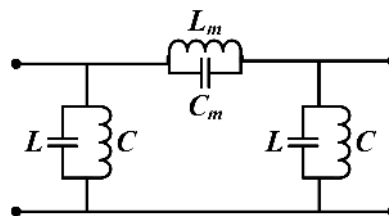

FIGURE 7. Equivalent circuit of electric and magnetic mixed coupling.

of perturbation slot, the current path of fundamental mode is changed, which influences the position of $RN1$, as is shown in Fig.6. As L_{arm} increases, the current path of fundamental mode keeps increasing, which makes the position of $RN1$ shift toward lower frequency.

$$E_c = \left[\frac{C_m}{C + C_m} \right]$$

$$M_c = \left[\frac{L}{L + L_m} \right] \quad (2)$$

Another radiation null ($RN2$) at upper stopband is generated through using mixed electric and magnetic coupling structure. The mixed coupling structure is composed of electric coupling structure and magnetic coupling structure. The equivalent circuit model of mixed electric and magnetic coupling is given in Fig.7 [18], [19]. As shown in Fig.7, mixed coupling coefficient can be expressed (2), where E_C represents electric coupling coefficient, M_C represents magnetic coupling coefficient [20]. E_C and M_C represent the strength of electric coupling and magnetic coupling, respectively, and decide the frequency of radiation null. Therefore, the frequency of radiation null is extracted by $\omega_{RN} = 1/\sqrt{L_m C_m}$, simply. In the area B, mixed coupling structure and cavity directly contact at parameter L_g . Mixed coupling structure and cavity share the same current path, therefore the magnetic coupling is main coupling here. In the area A, coupling structure and cavity are not directly in contact, and there exists gap structure. Therefore, electric coupling is dominating here. The position of radiation null can be controlled by changing the strength of electric and magnetic mixed coupling.

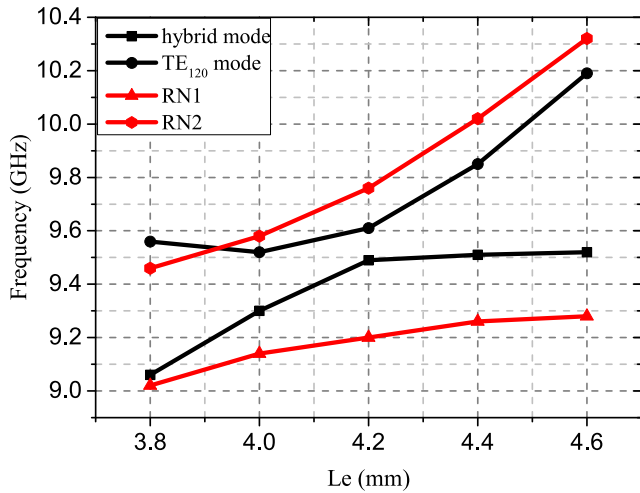

FIGURE 8. Frequency response with changing Le .

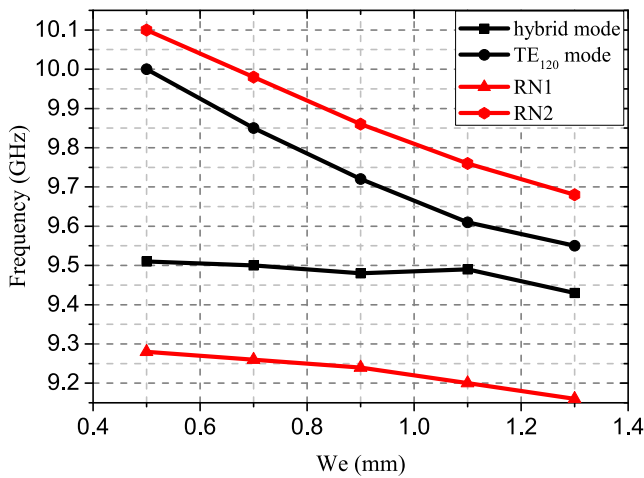

FIGURE 9. Frequency response with changing We .

We and Var_l are key parameters to adjust the strength of magnetic coupling. The length of mixed coupling structure Le is the key parameter to adjust the strength of electric coupling. As are shown in Fig.8 and Fig.9, with parameters We and Le changing, the strength of mixed electric and magnetic coupling is changed, leading to the change of the position of $RN2$. However, varying parameters We and Le , the surface current of path of resonances is changed, resulting in varying frequency of resonances. Parameters We and Le cannot realize $RN2$ controllability, independently. As is shown in Fig.10, changing Var_l only affects the strength of mixed electric and magnetic coupling. Var_l is located on the bottom of feed structure, varying Var_l does not affect surface current of path of resonances. Thus, with the varying of Var_l , the position of $RN2$ can be changed independently. The size of mixed coupling structure is optimized, and $RN2$ is obtained, locating on the right side of passband. As shown in Fig.11, with the parameter Var_l increasing, the strength of magnetic coupling decreases and the position of $RN2$ shifts toward lower frequency.

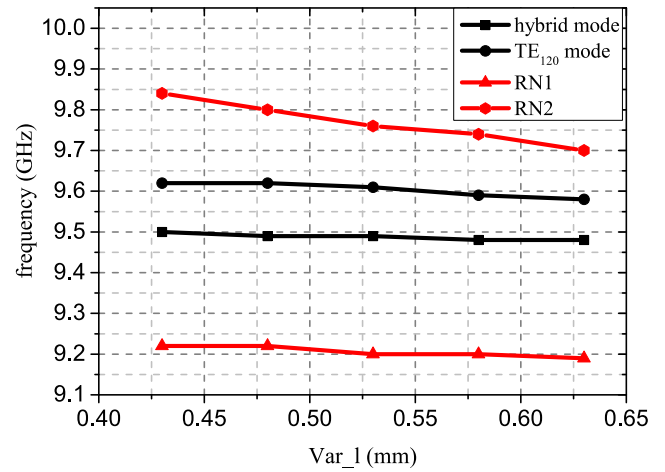

FIGURE 10. Frequency response with changing Var_l .

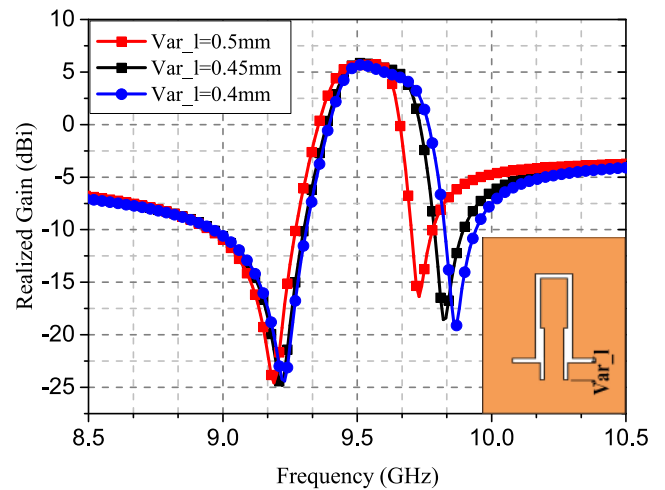

FIGURE 11. Position of $RN2$ with changing Var_l .

D. DESIGN GUIDELINES

Based on the above analysis, a design guideline is recommended as follows.

- 1) Designing the dimensions of SIW cavity with a proper feedline according to the desired center frequency.
- 2) Determining the frequencies of the required radiation nulls outside the operating band.
- 3) Etching perturbation slot and electric and magnetic coupling structure in the SIW cavity, and then optimizing their dimensions to make radiation null at suitable positions.
- 4) Fine tune parameters and optimize the design to realize a filtering performance.

III. MEASUREMENTS RESULTS

The photograph of antenna fabricated is shown in Fig.12. The slot and mixed coupling structure are etched on the top surface of SIW cavity fabricated by printed circuit board technology. The simulated and measured reflection coefficient and realized gain are plotted in Fig.12. From the Fig.12, it can be seen that an excellent agreement between measured results

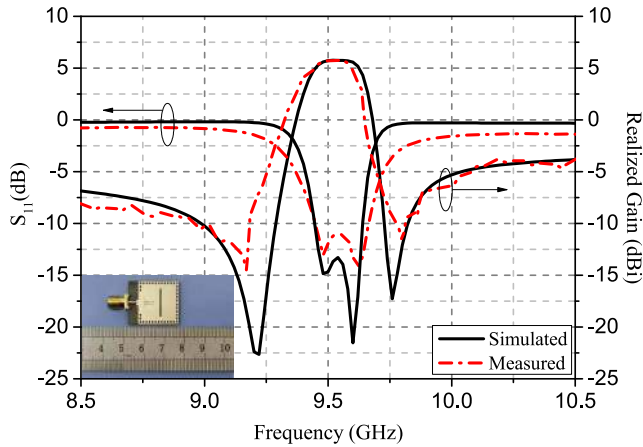

FIGURE 12. Comparison between simulated and measured results of the proposed antenna.

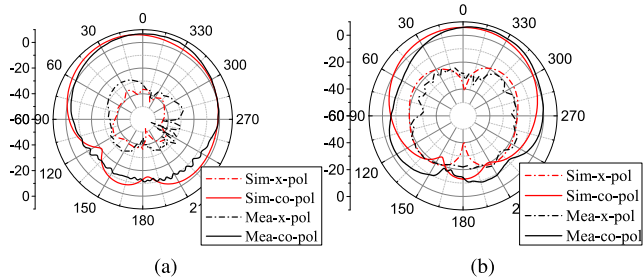

FIGURE 13. Radiation patterns of antenna at 9.49GHz. (a) y-z plane (b) x-z plane.

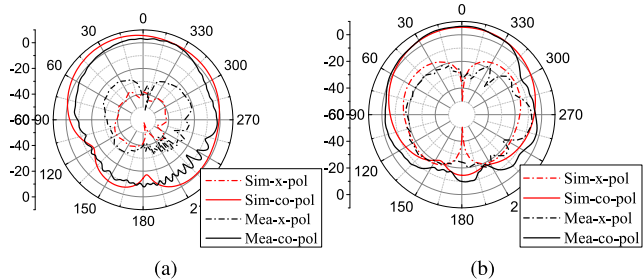

FIGURE 14. Radiation patterns of antenna at 9.62GHz. (a) y-z plane (b) x-z plane.

with simulated one. Two resonances are excited, leading to a flat passband. The measured operating bandwidth is from 9.44 GHz to 9.68 GHz with reflection coefficient lower than -10 dB. The obtained maximum of realized gain is 5.8 dBi. As expected, two radiation nulls are generated in the upper and lower stopband, respectively. An excellent quasi-elliptic filtering response is obtained. However, there exists some deviation in the plot, due to fabrication tolerances.

The radiation patterns of the proposed antenna are shown in Fig.13 and Fig.14. The E-plane (y-z plane) and H-plane (x-z plane) measured patterns are compared with simulated results. Cross-polarization levels are lower than -20 dB in both planes. A comparison with previous works is tabulated in Table 1. It can be found the proposed antenna has advantage in generation and controllability of radiation nulls.

TABLE 1. Comparison with previous SIW filtering antennas.

Ref.	BW(%)	Gain(dBi)	Extra Filtering Circuit	Controllable Radiation Null	Number of Radiation Nulls
[7]	2.4/6	5.94	Yes	No	0
[8]	5.1	6.3	Yes	Yes	2
[11]	8.29	5.1	No	Yes	1
[15]	4.04	5.39	No	No	2
This work	2.53	5.8	No	Yes	2

The proposed filtenna has no extra filtering circuit, which increases designing complexity, and keeps an excellent in-band antenna performance and filtering performance.

IV. CONCLUSION

A substrate integrated waveguide filtenna with two controllable radiation nulls is presented, designed and fabricated. Two resonant mode are excited through electric and magnetic mixed coupling structure to produce a flat frequency response. The maximum realized gain can reach 5.8 dBi. Exciting fundamental mode and loading electric and magnetic mixed coupling structure can generate two radiation nulls to realize a quasi-elliptic filtering response. The measured results also verify the correctness of the proposed antenna. Radiation patterns show a great unidirectional radiation characteristic and low cross-polarization levels.

REFERENCES

- [1] W. Hong, K. Wu, H. Tang, J. Chen, P. Chen, Y. Cheng, and J. Xu, "SIW-like guided wave structures and applications," *IEICE Trans. Electron.*, vols. E92-C, no. 9, pp. 1111–1123, 2009.
- [2] M. Bozzi, A. Georgiadis, and K. Wu, "Review of substrate-integrated waveguide circuits and antennas," *IET Microw., Antennas Propag.*, vol. 5, no. 8, pp. 909–920, Jun. 2011.
- [3] G. Qing Luo, Z. Fang Hu, L. Xi Dong, and L. Ling Sun, "Planar slot antenna backed by substrate integrated waveguide cavity," *IEEE Antennas Wireless Propag. Lett.*, vol. 7, pp. 236–239, 2008.
- [4] S. Mukherjee, A. Biswas, and K. V. Srivastava, "Substrate integrated waveguide cavity-backed dumbbell-shaped slot antenna for dual-frequency applications," *IEEE Antennas Wireless Propag. Lett.*, vol. 14, pp. 1314–1317, 2015.
- [5] G. Qing Luo, Z. Fang Hu, Y. Liang, L. Yang Yu, and L. Ling Sun, "Development of low profile cavity backed crossed slot antennas for planar integration," *IEEE Trans. Antennas Propag.*, vol. 57, no. 10, pp. 2972–2979, Oct. 2009.
- [6] P. Li, H. Chu, D. Zhao, and R. S. Chen, "Compact dual-band balanced SIW bandpass filter with improved common-mode suppression," *IEEE Microw. Wireless Compon. Lett.*, vol. 27, no. 4, pp. 347–349, Apr. 2017.
- [7] K. Dhawaj, H. Tian, and T. Itoh, "Low-profile dual-band filtering antenna using common planar cavity," *IEEE Antennas Wireless Propag. Lett.*, vol. 17, no. 6, pp. 1081–1084, Jun. 2018.
- [8] K.-Z. Hu, M.-C. Tang, D. Li, Y. Wang, and M. Li, "Design of compact, single-layered substrate integrated waveguide filtenna with parasitic patch," *IEEE Trans. Antennas Propag.*, vol. 68, no. 2, pp. 1134–1139, Feb. 2020.
- [9] K. Dhawaj, X. Li, L. J. Jiang, and T. Itoh, "Low-profile diplexing Filter/Antenna based on common radiating cavity with quasi-elliptic response," *IEEE Antennas Wireless Propag. Lett.*, vol. 17, no. 10, pp. 1783–1787, Oct. 2018.
- [10] H. Jin, G. Q. Luo, W. Wang, W. Che, and K.-S. Chin, "Integration design of millimeter-wave filtering patch antenna array with SIW four-way anti-phase filtering power divider," *IEEE Access*, vol. 7, pp. 49804–49812, 2019.

- [11] R. Lovato and X. Gong, "A third-order SIW-integrated Filter/Antenna using two resonant cavities," *IEEE Antennas Wireless Propag. Lett.*, vol. 17, no. 3, pp. 505–508, Mar. 2018.
- [12] P. K. Li, C. J. You, H. F. Yu, X. Li, Y. W. Yang, and J. H. Deng, "Code-signed high-efficiency single-layered substrate integrated waveguide filtering antenna with a controllable radiation null," *IEEE Antennas Wireless Propag. Lett.*, vol. 17, no. 2, pp. 295–298, Feb. 2018.
- [13] K. Dhawaj, J. M. Kovitz, H. Tian, L. J. Jiang, and T. Itoh, "Half-mode cavity-based planar filtering antenna with controllable transmission zeroes," *IEEE Antennas Wireless Propag. Lett.*, vol. 17, no. 5, pp. 833–836, May 2018.
- [14] B.-J. Niu, J.-H. Tan, and S.-W. Wong, "Compact SIW cavity slot antenna with enhanced bandwidth and quasi-elliptic filtering response," *Electron. Lett.*, vol. 55, no. 2, pp. 69–70, Jan. 2019.
- [15] B.-J. Niu and J.-H. Tan, "Dual-layer SIW cavity filtering antenna with a controllable radiation band and two radiation nulls," *Electron. Lett.*, vol. 55, no. 13, pp. 723–724, Jun. 2019.
- [16] G. Q. Luo, Z. F. Hu, W. J. Li, X. H. Zhang, L. L. Sun, and J. F. Zheng, "Bandwidth-enhanced low-profile cavity-backed slot antenna by using hybrid SIW cavity modes," *IEEE Trans. Antennas Propag.*, vol. 60, no. 4, pp. 1698–1704, Apr. 2012.
- [17] F. Xu and K. Wu, "Guided-wave and leakage characteristics of substrate integrated waveguide," *IEEE Trans. Microw. Theory Techn.*, vol. 53, no. 1, pp. 66–73, Jan. 2005.
- [18] P. Chu, W. Hong, L. Dai, H. Tang, J. Chen, Z. Hao, X. Zhu, and K. Wu, "A planar bandpass filter implemented with a hybrid structure of substrate integrated waveguide and coplanar waveguide," *IEEE Trans. Microw. Theory Techn.*, vol. 62, no. 2, pp. 266–274, Feb. 2014.
- [19] H. Wang and Q.-X. Chu, "An inline coaxial quasi-elliptic filter with controllable mixed electric and magnetic coupling," *IEEE Trans. Microw. Theory Techn.*, vol. 57, no. 3, pp. 667–673, Mar. 2009.
- [20] Q.-X. Chu and H. Wang, "A compact open-loop filter with mixed electric and magnetic coupling," *IEEE Trans. Microw. Theory Techn.*, vol. 56, no. 2, pp. 431–439, Feb. 2008.



HAIWEN LIU (Senior Member, IEEE) received the B.S. degree in electronic system and the M.S. degree in radio physics from Wuhan University, Wuhan, China, in 1997 and 2000, respectively, and the Ph.D. degree in microwave engineering from Shanghai Jiao Tong University, Shanghai, China, in 2004. From 2004 to 2006, he was with Waseda University, Kitakyushu, Japan, as a Research Assistant Professor. From 2006 to 2007, he was a Research Fellow with Kiel University, Kiel, Germany, where he was granted the Alexandervon Humboldt Research Fellowship. From 2007 to 2008, he was a Professor with the Institute of Optics and Electronics, Chengdu, China, where he was supported by the 100 Talents Program of Chinese Academy of Sciences. Since 2009, he has been a Chair Professor with East China Jiaotong University, Nanchang, China. He has published more than 100 papers in international and domestic journals and conferences. His current research interests include electromagnetic modeling of high-temperature superconducting circuits, radio frequency and microwave passive circuits and systems, antennas theory, and radar systems. He has served as a Technical Program Committee Member for many international conferences and a Reviewer for some international journals, including the IEEE Transactions on Microwave Theory and Techniques, the IEEE Transactions on Applied Superconductivity, the IEEE Transactions on Industrial Electronics, the IEEE Microwave and Wireless Components Letters, and the IEEE Antennas and Wireless Propagation Letters. He was a recipient of the Best Paper Prize from the 2005 International Conference on Communications, Circuits and Systems Proceedings in Hong Kong, the Prize of Osaka City Mayor for Conference of Chinese Alumni, Japan, in 2005, the 100 Best Ph.D. Dissertations in Shanghai, China, in 2006, and the Wang Kuancheng Science Foundation, in 2008.



CHUANYUN WANG (Student Member, IEEE) received the M.S. degree from East China Jiaotong University, Nanchang, China. He is currently pursuing the Ph.D. degree in electronic science and technology from Xi'an Jiaotong University, Xi'an, China.

He is currently a Teacher with East China Jiaotong University. His current research interests include microwave antenna, millimeter-wave antenna, and dielectric resonator antenna.



XIN WANG received the B.S. degree in communication engineering from East China Jiaotong University, Nanchang, China, in 2017, where he is currently pursuing the M.S. degree in microwave engineering.

His current research interests include SIW antenna, filtering antenna, and microwave circuit.



ZHIHAO CHEN (Member, IEEE) received the B.Sc. degree from the Beijing University of Posts and Telecommunications (BUPT) and the B.Sc. (Eng.) (Hons.) and the Ph.D. degree in electronic engineering from the Queen Mary University of London in 2010 and 2014, respectively.

In 2014, she joined the School of Electronic Engineering, BUPT, as a Lecturer. She was a Secondment with Ace-Axis Wireless Technology Laboratories Ltd., Essex, U.K., in 2012. In 2013, she joined Northeastern University, Boston, MA, USA, as a Visiting Student. Her research interests include millimeter-wave antennas and dielectric resonator antennas. She received the Best Paper Award from iWAT 2013, Karlsruhe, Germany, the Third Prize Student Paper Competition from APS/URSI 2013, Orlando, FL, USA, the TICRA Travel Grant from EuCAP 2014, Hague, The Netherlands, and Third Place from the QMUL Three-Minute Thesis Competition Final 2014, London, U.K.



ZHIWEN HAN received the B.S. degree in communication engineering from Jiujiang University, Jiujiang, China, in 2018. He is currently pursuing the M.S. degree in communication and information system with East China Jiaotong University, China.

His current research interests include SIW antenna, filtering antenna, and microwave circuit.

• • •