

# UC Berkeley

## UC Berkeley Previously Published Works

### Title

Subsurface Characterization at Ground Failure Sites in Adapazari, Turkey

### Permalink

<https://escholarship.org/uc/item/48t8k8cd>

### Journal

Journal of Geotechnical & Geoenvironmental Engineering, 130(7)

### Authors

Bray, Jonathan D  
Sancio, Rololfo B  
Durgunoglu, Turan  
et al.

### Publication Date

2004

Peer reviewed

# Subsurface Characterization at Ground Failure Sites in Adapazari, Turkey

Jonathan D. Bray<sup>1</sup>; Rodolfo B. Sancio<sup>2</sup>; Turan Durgunoglu<sup>3</sup>; Akin Onalp<sup>4</sup>; T. Leslie Youd<sup>5</sup>; Jonathan P. Stewart<sup>6</sup>; Raymond B. Seed<sup>7</sup>; Onder K. Cetin<sup>8</sup>; Ertan Bol<sup>9</sup>; M. B. Baturay<sup>10</sup>; C. Christensen<sup>11</sup>; and T. Karadayilar<sup>12</sup>

**Abstract:** Ground failure in Adapazari, Turkey during the 1999 Kocaeli earthquake was severe. Hundreds of structures settled, slid, tilted, and collapsed due in part to liquefaction and ground softening. Ground failure was more severe adjacent to and under buildings. The soils that led to severe building damage were generally low plasticity silts. In this paper, the results of a comprehensive investigation of the soils of Adapazari, which included cone penetration test (CPT) profiles followed by borings with standard penetration tests (SPTs) and soil index tests, are presented. The effects of subsurface conditions on the occurrence of ground failure and its resulting effect on building performance are explored through representative case histories. CPT- and SPT-based liquefaction triggering procedures adequately identified soils that liquefied if the clay-size criterion of the Chinese criteria was disregarded. The CPT was able to identify thin seams of loose liquefiable silt, and the SPT (with retrieved samples) allowed for reliable evaluation of the liquefaction susceptibility of fine-grained soils. A well-documented database of in situ and index testing is now available for incorporating in future CPT- and SPT-based liquefaction triggering correlations.

**DOI:** 10.1061/(ASCE)1090-0241(2004)130:7(673)

**CE Database subject headings:** Cone penetration tests; Earthquakes; Fine-grained soils; Liquefaction; Silts; In situ tests; Subsurface environment; Turkey.

## Introduction

In Adapazari, Turkey, hundreds of buildings settled, tilted, and collapsed during the August 17, 1999 Kocaeli earthquake ( $M_w = 7.4$ ) due in part to liquefaction and ground softening. These case records provide an exceptional opportunity to advance the profession's understanding of ground failure and its effects on structures. Consequently, an extensive field investigation program

was carried out at selected building sites and along streets surveyed previously in Adapazari to document the subsurface conditions of this city. The site investigation program included 135 cone penetration test (CPT) profiles and 46 exploratory borings with closely spaced standard penetration tests (SPT) with energy measurements.

The objectives of this paper are to share the results of this comprehensive field-testing program that characterizes the subsurface conditions in Adapazari and to relate observations of ground failure and structural damage to subsurface conditions. Whereas an earlier paper by Sancio et al. (2002) documented the correlation between ground failure and soil conditions along streets that had been surveyed in the postearthquake reconnaissance, this paper focuses on individual building sites that demanded more intensive investigations. The results of liquefaction triggering analyses are presented, and the mechanisms that led to the observed performances are discussed. Insights are made regarding current liquefaction evaluation procedures.

## Overview of Damage in Adapazari Resulting from the 1999 Kocaeli Earthquake

A comprehensive summary of the observations of ground failure and building damage in the city of Adapazari, Turkey is presented in Bray and Stewart (2000), so the reader is directed to this work as well as to the internet report (Bray et al. 2001b) for additional information. A brief overview of the damage in Adapazari is presented for the sake of completeness.

Adapazari, which is home to over 180,000 people, is an important industrial and agricultural city in Northwestern Turkey. Both new construction and older construction exist in the city. The city is densely developed in most areas, primarily with 3 to 6

<sup>1</sup>Professor, Dept. of Civil and Environmental Engineering, Univ. of California, Berkeley, CA 94720-1710.

<sup>2</sup>Project Engineer, Golder Associates Inc., 15603 W. Hardy Rd., Houston, TX 77060.

<sup>3</sup>Professor, Bogaziçi Univ., Istanbul, Turkey.

<sup>4</sup>Professor, Istanbul Kultur Univ., Istanbul, Turkey.

<sup>5</sup>Professor, Brigham Young Univ., Provo, UT 84602-4081.

<sup>6</sup>Associate Professor, Univ. of California, Los Angeles, CA 90095-1593.

<sup>7</sup>Professor, Dept. of Civil and Environmental Engineering, Univ. of California, Berkeley, CA 94720-1710.

<sup>8</sup>Assistant Professor, Middle Eastern Technical Univ., Ankara, Turkey.

<sup>9</sup>Doctoral Candidate, Sakarya Univ., 54040 Adapazari, Turkey.

<sup>10</sup>Senior Staff Engineer, GeoSyntec Consultants, Walnut Creek, CA 94597.

<sup>11</sup>Doctoral Candidate, Brigham Young Univ., Provo, UT 84602-4081.

<sup>12</sup>Engineer, ZETAS Earth Technology Corporation, 81150 Istanbul, Turkey.

Note. Discussion open until December 1, 2004. Separate discussions must be submitted for individual papers. To extend the closing date by one month, a written request must be filed with the ASCE Managing Editor. The manuscript for this paper was submitted for review and possible publication on April 30, 2003; approved on August 14, 2003. This paper is part of the *Journal of Geotechnical and Geoenvironmental Engineering*, Vol. 130, No. 7, July 1, 2004. ©ASCE, ISSN 1090-0241/2004/7-673-685/\$18.00.

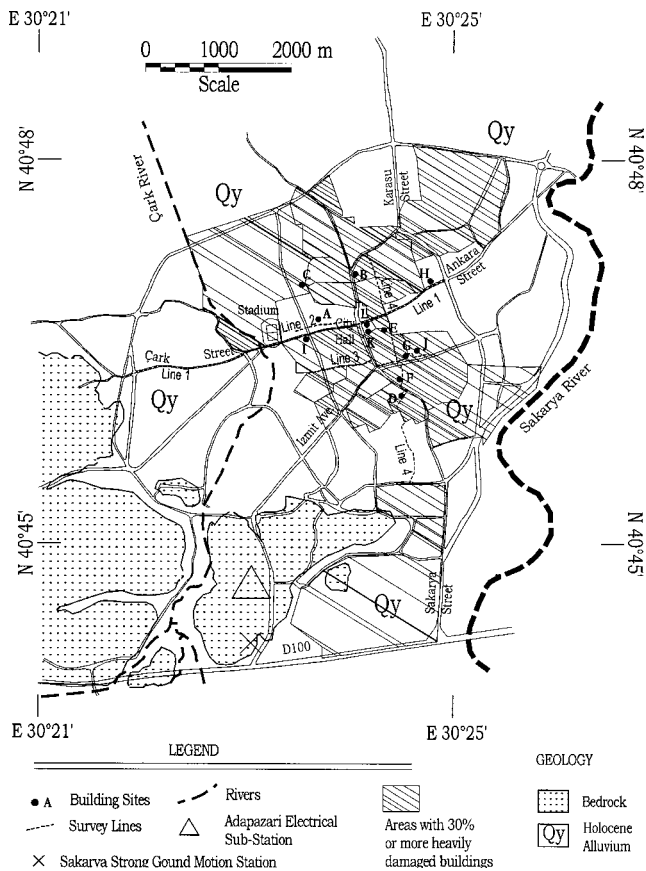
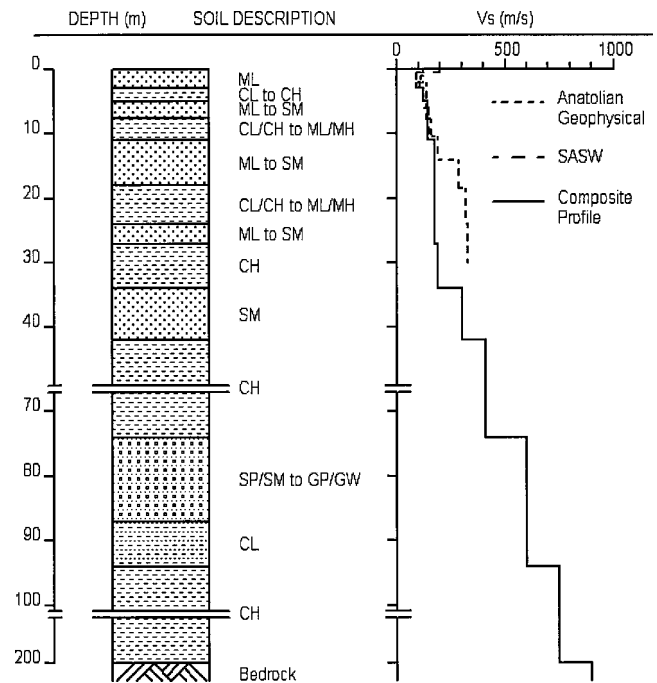

**Fig. 1.** Map of Adapazari showing key landmarks, surficial geology, and location of survey lines and building sites studied

story reinforced concrete frame buildings and 1 to 2 story timber/brick buildings. Reinforced concrete construction is primarily nonductile, with shallow, reinforced concrete mat foundations located at depths of about 1.5 m due to shallow groundwater, which varies seasonally, but is typically at a depth of 1 to 2 m.

Most of Adapazari, which in Turkish means “island market,” is located over recent Holocene alluvial sediments created by the meandering and frequently flooding Sakarya and Carik rivers (Fig. 1). As evidence of the active fluvial processes in the Adapazari basin, a masonry bridge built in 559 AD across the basin’s primary river is now 4 km west of its current alignment (Ambraseys and Zatopek 1969). An organic sample retrieved from a depth of 4 m at a site within the city was dated to be only 1,000 years old, and floods as recent as 50 years ago continued to deposit sediment throughout the city (Sancio 2003). Many soil profiles are characterized as loose silts and silty sands in the upper 4 to 5 m which overlie clay deposits with some silty sand layers, although at several locations a 4- to 5-m-thick layer of dense sand lies between the surficial silt/silty sand layer and the deeper clay layers and at other locations clayey soils replace the shallow deposits of silts (Bray et al. 2001b; Onalp et al. 2001; Sancio et al. 2002; Sancio 2003). The Adapazari basin is as deep as 200–400 m near the center of the city, but the alluvium thins toward the hills in the southwest part of the city.

Adapazari suffered the largest level of gross building damage and life loss of any city affected by the Kocaeli earthquake (Bray and Stewart 2000). Turkish federal government data indicate that a total of 5,078 buildings (27% of the building stock) were either severely damaged or destroyed. The “official” loss of life, based



**Fig. 2.** Generalized subsurface conditions and shear wave velocity profile used for seismic site response analysis

on the number of bodies recovered from buildings and visually identified by surviving acquaintances, was 2,627. The actual figure is likely much higher. Data from the ground surveys indicate that 20% of reinforced concrete buildings and 56% of timber/brick buildings were severely damaged or destroyed. Damage was concentrated in districts located on Holocene alluvium in the basin.

Rapid damage surveys were performed for each structure along several streets that traverse the city (referred to subsequently as “line” surveys). More detailed surveys were also performed at several specific building sites (Bray and Stewart 2000). A total of 719 structures were mapped in Adapazari, which is about 4% of the building stock. The line surveys allowed trends to be established regarding the relationship between subsurface conditions, ground failure, and building damage (Bray and Stewart 2000; Sancio et al. 2002). It was found that some of the intervals with ground failure also have significant structural damage, while others have only moderate structural damage. However, there are no broad areas with ground failure and light structural damage. Sand boils were observed within several of the ground failure zones, but they were not widespread. The compiled data indicate that the severity of structural damage increased with the level of ground failure (Bray and Stewart 2000). Additionally, ground failure was found to be more prevalent and more severe when shallow deposits of loose silts were present (Sancio et al. 2002).

### Seismic Demand in Adapazari from the Kocaeli Earthquake

The nearby Sakarya accelerograph recorded a peak horizontal (east-west) ground acceleration, velocity, and displacement of 0.41g, 81 cm/s, and 220 cm, respectively. The north-south (fault-normal) component failed to record the main event, but it likely contained a pulse-like motion due to forward-directivity. The Sakarya station is located in southwestern Adapazari at a distance

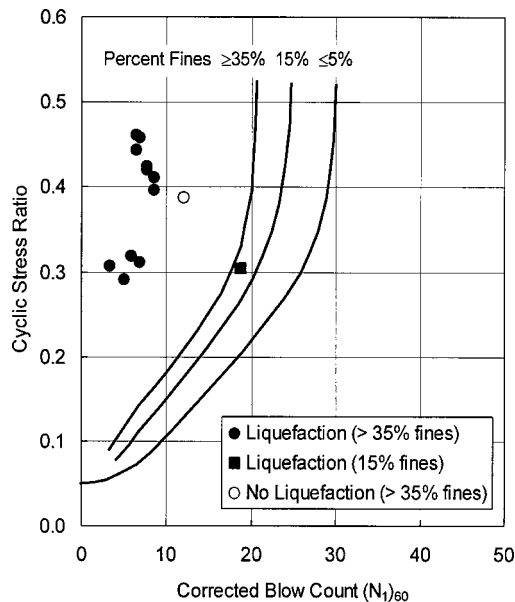

**Fig. 3.** Relationship between cyclic stress ratio and standard penetration test penetration resistance for sands and silty sands based on field performance data showing data for critical layers at selected sites in Adapazari [modified from Youd et al. (2001) after Seed et al. (1985)]

of 3.3 km from the fault rupture. It is situated on the floor of a small 1-story building (with no basement) and is underlain by a shallow deposit of stiff soil overlying bedrock [average  $V_s \sim 470$  m/s over the top 30 m, Rathje et al. (2003)]. Downtown Adapazari is located at a distance of about 7 km from the rupture, and motions there would differ from those at the accelerograph due to different site-source distances and ground response effects associated with the relatively soft and deep alluvium in the downtown area. Ground motions recorded at similar site-source distances on deep alluvium suggest that the peak ground acceleration (PGA) in Adapazari was on the order of 0.35–0.45g.

The downtown Adapazari motions were further investigated by performing ground response analyses using the program *SHAKE91* (Idriss and Sun 1992). Fig. 2 shows a representative soil column of downtown Adapazari based on a deep boring performed at Site G (see Fig. 1) by the General Directorate of Waterworks (DSI). Shear wave velocity ( $V_s$ ) measurements to a depth of 10 m were performed at this site using spectral analysis of surface waves (SASW) by Cox (2001) and to 30 m using Rayleigh wave inversion by Anatolian Geophysical (O. Yilmaz, personal communication, 2003). Additionally, SASW data to 50 m depth is available at Site J, which is about 150 m east of Site G and has similar subsurface conditions. These data form the basis for the  $V_s$  profile shown in Fig. 2 (average  $V_s \sim 150$  m/s over the top 30 m). The recorded motion scaled for the different source-site distance and deconvolved bedrock motions of the east-west component of the Sakarya station were used as input motions. The PGA was computed to be 0.35–0.55g. The upper range of these PGA estimates are slightly larger than those of empirical amplification models because the Adapazari alluvium is soft and the site response analyses predicted significant amplification of the midperiod spectral accelerations and consequently amplification of the PGA. However, the free-field cyclic stress ratios (CSRs) calculated from the site response analyses over a depth range of 1–10 m are only slightly larger than those calculated using the simplified CSRs procedure based on empirical estimates

**Table 1.** Procedure Used for the Standard Penetration Test

Drilling technique	Rotary wash with bentonite mud
Borehole support	Casing, only when necessary
Drill bit	Tri-cone bit, 9 cm diameter
Drill rod	AWJ type: area = 5.94 cm <sup>2</sup> , length = 1.52 m
Sampler	O.D. = 50.8 mm, I.D. = 35 mm (constant), length = 600 mm
Cathead and rope	2 1/4 turns of rope (2 cm diameter) on a clockwise rotating cathead (11.2 cm diameter)
Hammer type	Safety hammer
Penetration resistance	Blows recorded over three intervals, each 15 cm; $N$ = blows over last two intervals

Note: AWJ = abrasive water jet.

of PGA. The latter procedure was utilized to estimate CSRs as recommended by Youd et al. (2001).

The level of shaking in Adapazari was sufficiently intense that the CSRs induced in the critical soil layers within the upper 6 m by the earthquake were largely between 0.3 and 0.5. As shown in Fig. 3, over this range, the SPT- (and CPT-) based cyclic resistance ratio (CRR) curves are nearly vertical. Hence uncertainty in estimating the demand from this event for the free-field case does not significantly affect the liquefaction triggering assessment. However, the liquefaction assessment is highly sensitive to penetration resistance, so care was taken to employ standard U.S. methods and measure the actual SPT energy to achieve reliable normalized SPT blow-counts,  $(N_1)_{60}$ , and CPT tip resistances,  $q_{c1N}$ .

### In Situ Testing for Liquefaction Evaluation

The variability of the equipment and procedures used for the standard penetration test, and its effect on the blow-count has been extensively studied (e.g., Kovacs and Salomone 1982; Seed et al. 1985; Skempton 1986). The percentage of the total theoretical energy delivered to the split-spoon sampler, or energy ratio, is strongly influenced by many factors such as: type of hammer and its release mechanism; number of wraps of the rope around the cathead and their sizes; borehole diameter; rod diameter; length; tightness; and verticality of the rod; type of sampler; and operator expertise. This problem was recognized, and in an attempt to standardize the test, procedures stipulated in ASTM D6066-96 (2000a) and ASTM D1586-99 (2000b) were followed closely. Hence the energy transmitted to the sampler would be assumed to be 60% if no short-rod correction was applied. Table 1 summarizes the details of the SPT procedures used in this study.

The actual energy delivered by the system was measured for each blow of the hammer to accurately define the energy ratio and to account for possible short-rod corrections for the tests performed in the shallow soils of Adapazari. The energy was measured by installing two accelerometers and two strain gauges on a portion of the rod string. Integration of the force (from measured strain and Hooke's law) and velocity (from integration of the measured acceleration) over time permits calculation of the actual energy delivered by the system (Abou-Matar and Goble 1997). This calculation is completed automatically with the SPT Analyzer (Pile Dynamics, Inc.). Using the average energy ratio (ER) for each test, the blow-count normalized to 60% of the theoretical energy,  $N_{60}$ , was computed. These  $N_{60}$  values differed significantly from  $N$  values measured by local companies using donut hammers and nonstandard procedures.

Most of the soils in Adapazari contain significant fines (i.e., >35% passing the number 200 sieve). Hence, the CRR line shown in Fig. 3 for percent fines  $\geq 35\%$  is applicable for the vast majority of the SPT-based liquefaction triggering analyses. The liquefaction-triggering database of the well-used Seed et al. (1985) correlation, which was readopted with only a minor revision in Youd et al. (2001), is dominated by cases for clean sands and silty sands with less than 35% fines. Only 13 cases with more than 35% fines were available when this CRR line was developed.

Fine-grained soils also require characterization to evaluate their susceptibility to liquefaction with criteria such as the “Chinese criteria” (Seed and Idriss 1982). As restated in Youd et al. (2001), the Chinese criteria specifies that liquefaction can only occur if all three of the following conditions are met: (1) amount of particles smaller than  $5\ \mu\text{m} < 15\%$ ; (2) liquid limit (LL)  $< 35\%$ ; and (3) water content ( $w_n$ )  $> 0.9$  LL. Alternatively, Andrews and Martin (2000) state that silty soils are susceptible to liquefaction if both LL  $< 32\%$  and the percent less than  $2\ \mu\text{m} < 10\%$ . Only a limited number of retrieved soil specimens are classified as “Susceptible” using these criteria (Bray et al. 2001a). Most of these soils are classified as “Not Susceptible or Safe” regarding liquefaction by these criteria, although a number of them require further testing. Yet, postearthquake reconnaissance efforts such as those described by Bray and Stewart (2000) and follow-on studies by Sancio et al. (2002) clearly found ample evidence of liquefaction and ground softening at the sites where these data were collected. As suggested in Sancio et al. (2002) and Bray et al. (2004), the percent “clay-size” criterion of the Chinese criteria and Andrews and Martin (2000) criteria is misleading, because it is not the percent of “clay-size” particles that is important. Rather, it is the percent of clay minerals present in the soil and their activity that are important. Fine quartz particles may be smaller than  $5\ \mu\text{m}$ , but if largely nonplastic, these soils respond as a cohesionless material in terms of liquefaction. Accordingly, the percent “clay-size” criterion will not be used in this study to characterize fine-grained soils as potentially liquefiable.

CPT- and SPT-based liquefaction triggering analyses were performed based on the recommendations of Youd et al. (2001) with the exceptions that the clay-size criterion of the Chinese criteria was disregarded and the overburden correction factor,  $K_\sigma$ , was allowed to slightly exceed one for shallow soil deposits [i.e.,  $K_\sigma = (\sigma'_v)^{-0.3} \leq 1.4$ ; Hynes and Olsen (1999)]. Because the magnitude of the Kocaeli earthquake was nearly 7.5, no magnitude correction is necessary, however, examination of the acceleration-time histories recorded and shear stress-time histories calculated indicate that the equivalent number of cycles of loading for this event in Adapazari was on the order of 7–10 (Sancio 2003). One or two cycles of loading dominated the seismic demand, so that one could argue this event was more like a  $M_w = 6.5$  event than a  $M_w = 7.4$  event. However, to be consistent with the simplified procedure, no magnitude scaling factor was applied.

Care was exercised when applying the CPT-based liquefaction criteria proposed by Roberston and Wride (1998) when the soils contained significant fines (i.e., soil behavior type index,  $I_c > 2.4$ ), and adjacent SPTs with retrieved soil samples were relied upon more heavily. Analyses were performed for both free-field, level ground conditions and for conditions taking into account the effects of the structure (i.e.,  $K_\sigma$  and  $K_\alpha$  effects), which can have either a beneficial or detrimental influence on the liquefaction resistance of the soil according to Rollins and Seed (1990). However, in Adapazari, it appears that the static and inertial loading of the 2–6 story reinforced concrete structures were largely detri-

mental because ground failure was systematically found adjacent to structures and found to be less prevalent away from structures. Consistent with these observations, cyclic tests on these soils (Bray et al. 2004) indicate that the increased overburden pressure due to the buildings significantly decreased the soil's CRR, which made liquefaction more likely to occur under buildings.

## Site Investigations in Adapazari

During the summer of 2000, a total of 135 cone penetration test (CPT) profiles (of which 19 were seismic CPTs) and 46 soil borings with multiple standard penetration testing (SPT) (often at 0.8 m spacing) were completed in Adapazari to investigate the subsurface conditions at sites where ground failure was or was not observed. Most of the site investigation was limited to a depth of 10 m, but 28 CPT profiles and five soil borings were extended deeper to characterize soils to depths reaching 30 m. Details of this site investigation program (Bray et al. 2001b), including downloadable CPT profiles and boring logs, are available at the Pacific Earthquake Engineering Research Center (PEER) website: <http://peer.berkeley.edu/turkey/adapazari/index.html>. In addition, one very deep boring (200 m) was completed in a related research effort.

Initially, 40 CPT profiles and 29 soil borings were performed at 12 sites where buildings settled, tilted, or slid due to liquefaction or ground softening. The locations of these sites (denoted Sites A–L) where more detailed subsurface investigations were performed are shown in Fig. 1, which allows the reader to put these sites in context with the damage in Adapazari. An additional 90 CPTs and 14 borings were performed along the damage survey lines to identify geotechnical factors responsible for the observed ground failure. Lastly, five CPTs and three borings were completed at the Adapazari Electrical Substation, where damage to some components was observed. In this paper, four of the building sites where detailed subsurface information has been developed are discussed to illustrate the characteristics of the soils found in Adapazari and their potential effect on building performance. Additional information regarding the other sites and survey line data may be found at the aforementioned web site; Bray et al. (2001a); Sancio et al. (2002); and Sancio (2003).

## Illustrative Case History of Building Site C

### Observations

The dissimilar performance of three nearly identical reinforced concrete 5-story apartment buildings at Site C illustrates the important influence of variations in shallow soil deposits over short distances within Adapazari. The buildings are located in the Istiklal District of Adapazari (N40.78370° E30.39221°). The height, width, and length of these regular structures are approximately 13.7, 19.5, and 20.1 m, respectively. Thus their height-to-width ratio is 0.7. The overall structural design and construction of these buildings is similar to most of the reinforced concrete buildings studied in Adapazari. The foundation, which lies at a depth of about 1.5 m, consists of a 30-cm-thick reinforced mat with 1.2-m-deep intersecting grade beams. The superstructure consists of poorly detailed reinforced concrete beams and columns without shear walls; the structural frames can thus be classified as nonductile.

The middle building (designated C2 in Fig. 4) and the building to its north (designated C1) moved toward the street and down-

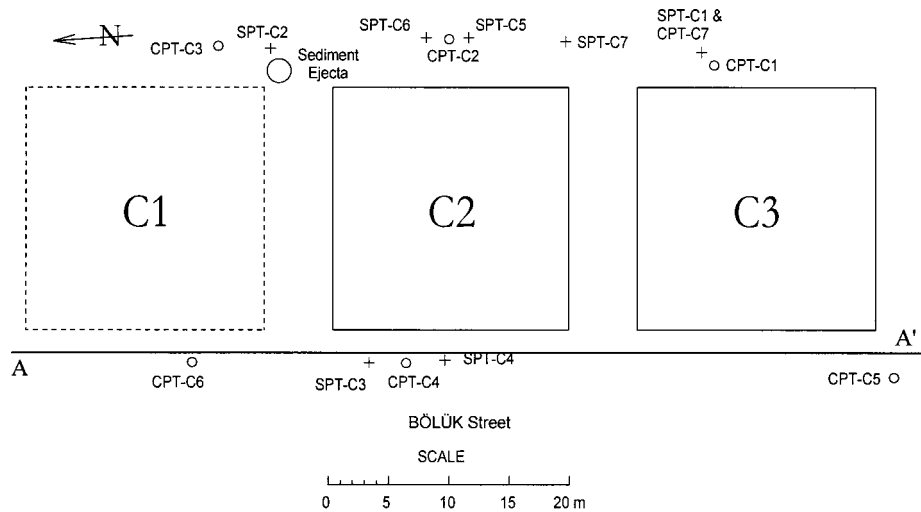

Fig. 4. Plan view of Site C and location of subsurface explorations

ward (Bray and Stewart 2000). For example, building C2 translated 57 cm towards the street (west), 34 cm towards building C1 (north), and the relative downward vertical movement between it and the pavement was about 35 cm. However, there was no evidence of distress to building C3, which is located directly south of building C2. Significant pavement distress and sediment ejecta were observed in the alley between buildings C1 and C2, but no ground failure was observed in the alley between buildings C2 and C3. The sediment ejecta is classified as a brown low plasticity sandy silt. Inspection of the structural components of buildings C2 and C3 showed no evidence of significant structural distress. Building C1 was demolished after the earthquake.

### Site Investigations

As shown in Fig. 4, six CPTs and seven exploratory borings were performed at Site C. The generalized subsurface conditions along the western side of the buildings are shown in Fig. 5. The subsurface conditions at this site appear to have significant variations

in both the vertical and horizontal direction as a result of the fluvial nature of the depositional environment.

Building C3's mat foundation is underlain by 2.5 m of tan brown plastic silty clay. Between approximately 4 and 5.5 m a red-brown to gray stratum of low plasticity medium dense sandy silts interspersed with more plastic clayey silts was identified. At approximately 6 m below the surface and down to about 8 m, a dense gray sand ( $q_{c1N} > 160$ ) with some fine gravel was found. Interbedded clayey silts and medium dense silty sands continue below this layer down to the extent of the exploration (~13 m).

Different than at building C3, the soil directly beneath the foundation of building C2 is a meter-thick deposit of loose, tan brown, low plasticity silt, with a water content consistently greater than 0.9 LL. Below this deposit down to a depth of about 8 m, the soils are interbedded loose to medium dense silts and sandy silts, with no dense clean sand with fine gravel layer as was present under building C3. Beyond a depth of 8 m and up to the

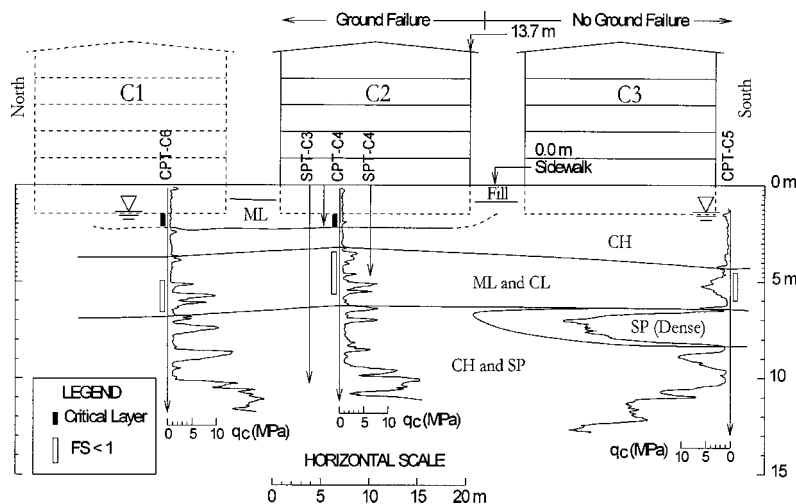
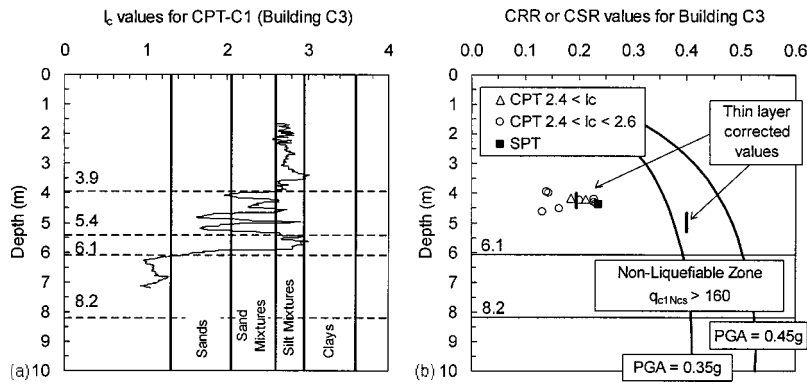

Fig. 5. North to south generalized soil profile of Site C (cross section A-A' in Fig. 4)



**Fig. 6.** (a) Soil behavior index ( $I_c$ ) values for CPT-C1 (Building C3), and (b) cyclic stress ratio (CSR) induced by the earthquake versus depth for free-field acceleration of 0.35g and 0.45g compared with the cyclic resistance ratio (CRR) of the soil for Building C3

extent of the exploration, the soil characteristics below building C2 are similar to those found below building C3.

### Liquefaction Evaluation

Some limited portions of the stratum of sandy silt found between depths of 3.9 and 5.4 m under building C3 are possibly liquefiable [ $I_c < 2.6$  as shown in Fig. 6(a)]. Samples retrieved from these soils have  $LL = 26-36$ , with water contents near the  $LL$ , and clay contents ( $\% < 5 \mu m$ ) close to, but generally exceeding, 15%. Due to the low liquid limits and high water contents, these thin silt layers are considered potentially liquefiable, although these soils would not be liquefiable if the Chinese criteria are strictly applied. The free-field CSR for PGA values of 0.35 and 0.45g are greater than the cyclic resistance of these soils [Fig. 6(b)]. The SPT data from a nearby boring corroborates this finding. The dense sand stratum (6.1–8.2 m), the clean to silty sand layer (8.5–9.3 m), and the medium dense to dense gray low plasticity silt to silty sand (10–13 m) are susceptible to liquefaction based on soil type, but only the layer between 8.5 and 9.3 m has  $(q_{c1N})_{cs}$  values lower than 160, which is the asymptote of the Robertson and Wride (1998) clean sand liquefaction-triggering curve. Hence liquefaction of these dense sands is not likely even at the high CSRs experienced in Adapazari.

The loose, low plasticity silt at a depth from 1.4 to 2.6 m, which is directly below the mat foundation of building C2, is judged to have liquefied based on the low  $I_c$  values ( $< 2$ ) and estimated CRR values of about 0.15 (Fig. 7). Over this depth

interval, soil samples indicate  $FC = 66-87$ ,  $LL = 23-33$ ,  $w_n/LL = 1-1.3$ , and clay content ( $\% < 5 \mu m$ ) between 14 and 28%. The characteristics of the sediment ejecta found between buildings C2 and C1 are consistent with those of the shallow low plasticity silt. This further indicates that the shallow loose silt deposit liquefied. At greater depths, numerous loose to medium dense layers of silt to silty sand found between 3.45 and 7.25 m have  $I_c$  values lower than 2.6. These silts have  $LL < 31$  and  $w_n/LL \sim 1$ , but clay contents  $> 23\%$ . Again, these soils are considered potentially liquefiable for this study. As can be seen in Fig. 7(b), the values of the soil's CRR obtained from the analysis of CPT-C4 and neighboring SPTs in the range of depth of 3.45–7.25 m is lower than the free-field CSR for  $PGA = 0.35g$ , and hence these strata most likely liquefied. Below a depth of 8 m, the soil liquefaction evaluation for building C2 is consistent with that previously presented for soils below building C3.

### Discussion

Reexamining Fig. 5, which also identifies layers with  $FS_l < 1$  and the critical layer with respect to liquefaction, there are two significant differences in the soil conditions below building C2, which underwent severe ground failure, and the "undamaged" building C3, which did not. Most importantly, loose, liquefiable, low plasticity sandy silts lie directly beneath building C2, but are absent directly under building C3. The liquefaction of these soils directly below building C2's mat foundation most likely led to the observed horizontal translation of the building on the order of 66

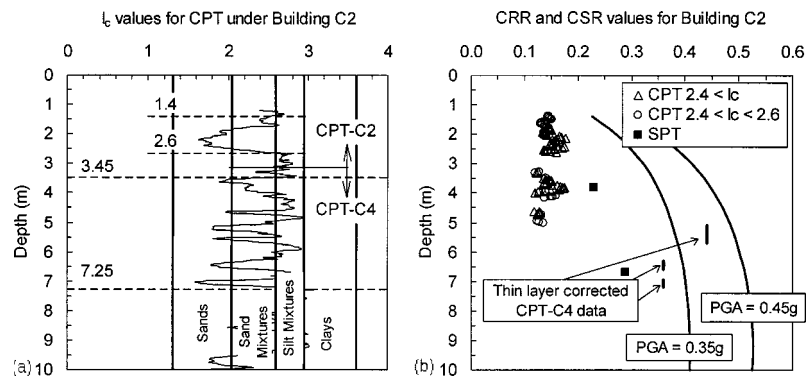

**Fig. 7.** (a) Soil behavior index ( $I_c$ ) values for CPT-C4 (Building C2), and (b) cyclic stress ratio (CSR) induced by the earthquake versus depth for free-field acceleration of 0.35g and 0.45g compared with the cyclic resistance ratio (CRR) of the soil for Building C2



**Fig. 8.** Four-story building at Site F that underwent significant vertical and lateral displacement. Note gap between street and building that a felled tree was thrown in after the earthquake.

cm. Additionally, at a depth of 6–8 m, a layer of dense sand with fine gravel that should not have liquefied under building C3 is in sharp contrast to the alternating layers of liquefiable silty sands and low plasticity silts in the soil deposit underlying building C2 over a similar depth, and this may have also contributed to ground failure being observed at building C2, but not at building C3.

The fluvial nature of the deposition of soils in Adapazari is important in understanding the occurrence and nonoccurrence of ground failure and building damage. At Site C, subsurface conditions changed dramatically over a short distance between buildings C3 and C2, and this largely explains the significantly different performance of these buildings. These analyses were performed for free-field, level ground conditions and do not take into consideration the inertial effect of the structure, which most likely contributed to lateral displacement of the building as well as ground failure beneath the building foundations.

## Illustrative Case History of Building Site F

### Observations

The 4-story, reinforced concrete apartment building shown in Fig. 8 is located in the Yenigün District (N40.77148° E30.40795°). The foundation of this structure consists of a 40-cm-thick reinforced concrete mat strengthened with 120-cm-high grade beams. The dimensions of the building are 13 m (E-W) by 7.7 m (N-S), with a height of 10.8 m, and a height-to-width ratio of 1.4. This building experienced 90 cm of downward movement relative to the surrounding pavement. Additionally, it translated approximately 25 cm towards the west (away from the street) and 30–40 cm to the north (away from photographer in Fig. 8). No significant foundation distress was observed, and the structural frame was essentially undamaged, indicating that the foundation underwent essentially rigid-body displacement.

### Site Investigations

At Site F, three CPT profiles and one boring with SPT were performed to characterize the foundation soils. The depth of the water table was about 1.9 m. The generalized subsurface profile below the building is shown in Fig. 9. Although the soils were explored to a depth of 27 m, only the upper 15 m are shown, as

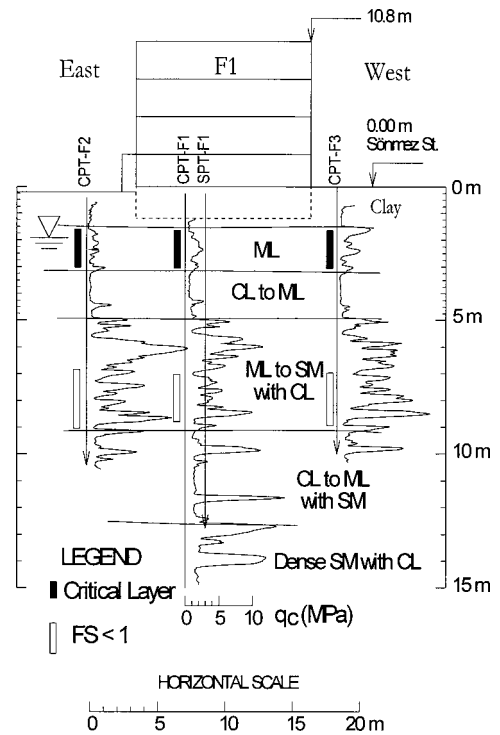

**Fig. 9.** East to west generalized subsurface soil profile of Site F

only the soils to this depth are judged to have had a significant effect on the observed ground failure.

The surficial soils consist of 1.5 m of clayey fill, underlain by 1.7 m of loose [ $(N_1)_{60}=7$ ], low plasticity ( $LL<30$ ), and high water content ( $w_c/LL>0.9$ ) brown to reddish brown silt to sandy silt. Zones with higher clay content were identified to have a pronounced reddish coloring, perhaps due to oxidation of ferric minerals. From 3.2 m to approximately 5 m lies a stratum of brown silty clay to clayey silt with some fine sand. At approximately 5 m, the soil color changes from brown to gray and the soil changes to medium dense gray nonplastic sandy silt and silty fine sand ( $35\%<FC<77\%$ ) interspersed with thin silty clay strata. These sequences extend to a depth of approximately 9 m. The normalized SPT penetration resistance ranges between 14 and 22. However, given the high stratification in this depth range, these values may be influenced by the lower penetration resistance of the softer interbedded thin silty clay strata, as seldom do the thicker, stiffer silt deposits have a thickness greater than 50 cm. A 3.5-m-thick stratum of gray silty clay to clayey silt interbedded with occasional thin, medium dense to dense silty sand was found underlying the upper deposits of sandy silt.

### Liquefaction Evaluation

Fig. 10(a) shows where the soils had values of  $I_c<2.6$  in a representative CPT profile. Comparisons between the free-field CSR induced by the earthquake and CRR of the soils susceptible to liquefaction are shown in Fig. 10(b). The CSR induced by the earthquake is significantly greater than the CRR of the soil in Zone A; thus the shallow, loose silt is judged to have liquefied.

The large fluctuations of the cone tip penetration resistance in Zone B indicate significant soil stratification as shown in Fig. 10(c). In this zone, the stiffer layers are seldom greater than 40



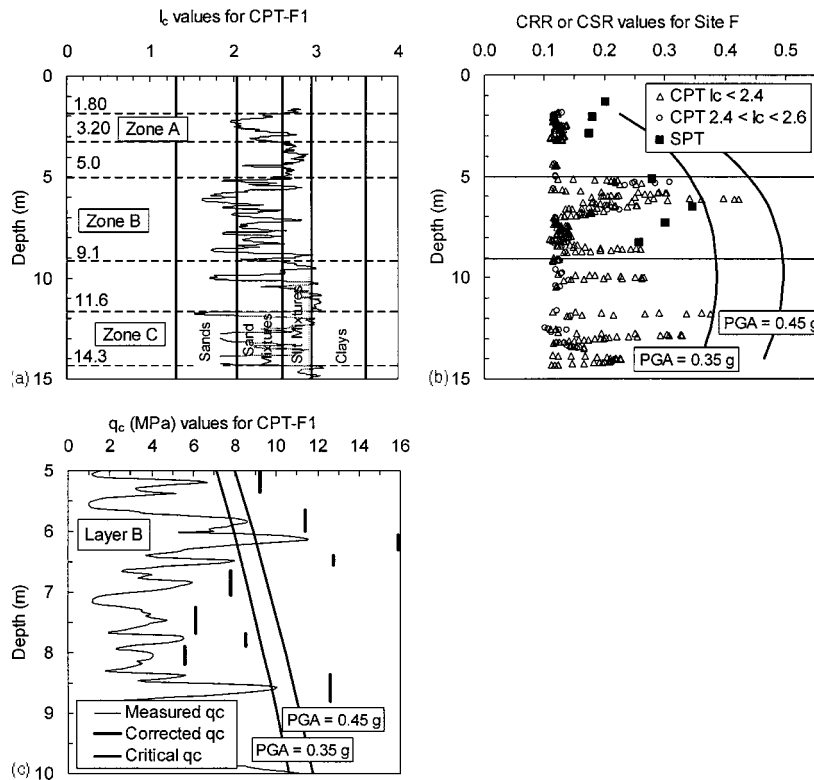

**Fig. 10.** Representative soil data for Building F: (a) Soil behavior index ( $I_c$ ) values for CPT-F1, (b) cyclic stress ratio (CSR) induced by earthquake versus depth for peak ground acceleration (PGA)=0.35g and 0.45g compared with the cyclic resistance ratio (CRR) of the soil, and (c) measured  $q_c$ , thin layer corrected  $q_c$ , and critical  $q_c$  for PGA=0.35g and 0.45g versus depth for Zone B

cm; therefore the full penetration resistance is not sensed by the 10 cm<sup>2</sup> cone tip used in these studies. These layers would need to be thicker than 75 cm for the tip resistance to reach its maximum value (Lunne et al. 1997). A correction factor as recommended by Youd et al. (2001) has been applied to the stiffer silt layers, which are susceptible to liquefaction, as shown in Fig. 10(c). Thin-layer corrections indicate that much of the Zone B soil did not liquefy for PGA<0.45g (i.e., all but four thin layers at depths of around 6.5–8 m). Consistent with the CPT results, the equivalent clean sand normalized SPT value,  $(N_1)_{60-CS}$ , exceeded 30 for some of the silt lenses indicating that much of the Zone B soils did not liquefy. Once thin layer corrections are made to the susceptible soil layers in Zone C, they are found to have not liquefied.

### Discussion

The liquefaction triggering analysis has shown that it is probable that the observed downward movement and translation experienced by the building was primarily due to liquefaction of the upper brown silty soils (as delineated in Fig. 9). The intense stratification of the gray silty sandy soils in the depth range of 5–9 m (Zone B) makes it difficult to apply the SPT and/or CPT based simplified procedures for determining liquefaction potential, as weaker nonliquefiable clayey strata decrease the soil's penetration resistance. However, once appropriate thin layer corrections are applied, much of these sandy silt strata are judged to have not liquefied, except for a few thin layers at depths of around 6.5–8 m.

### Illustrative Case History of Building Site I

#### Observations

The group of buildings shown in Fig. 11 corresponds to a block located along Çark Avenue (Line 1) in the Semerciler District, Adapazari (N40.77681° E30.39223°). Consistent with most foundation systems in Adapazari, building I3 is founded on a 35-cm-thick mat foundation, reinforced with 1.2-m-deep tie-beams. The height-to-width ratio for these buildings is between 1.1 and 1.3. The first building of the group from east to west, designated I1, experienced total failure of the columns of its first

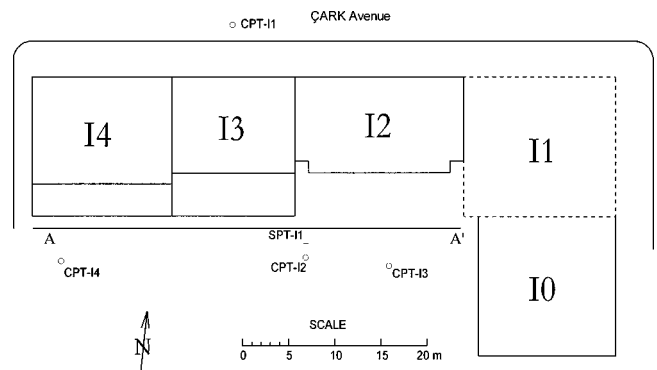

**Fig. 11.** Plan view of Site I and location of subsurface exploration points

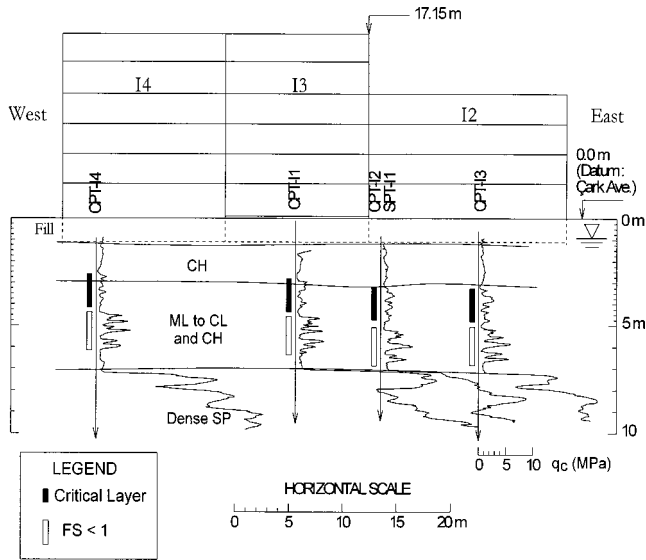

**Fig. 12.** West to east generalized soil profile of Site I (cross section A-A' in Fig. 11)

story. The other four buildings suffered light to moderate structural damage. Buildings I3 and I4 have 6 stories each and displaced vertically relative to the surrounding ground 17 and 12 cm, respectively. Building I2 has only 4 stories, but it moved downward 30–35 cm. Brown soil ejecta were found about 25 m south of building I1.

### Site Investigations

As indicated in Fig. 11, four CPT profiles and one exploratory boring with SPT were performed at this site. The water table was found to be at a depth of about 0.8 m. The site's generalized subsurface profile is shown in Fig. 12. Directly below the foundation level and to a depth of approximately 3 m lies a stratum of stiff high plasticity gray silty clay. A sequence of highly stratified brown low plasticity sandy silt, clayey silt, and high plasticity silty clay was found from 3 to 7 m. The color of the soil in this deposit transitions to gray at about 4 m. The normalized SPT penetration resistance  $[(N_1)_{60}]$  of the soils between 3 and 5 m is about 7, and about 14 for the soils between 5 and 7 m. Below 7 m

and up to the maximum depth explored ( $\sim 10$  m) lies a dense  $[q_{c1N} > 160$  and  $(N_1)_{60} > 30]$  stratum of poorly graded gray sand with some silt ( $FC < 10\%$ ).

### Liquefaction Evaluation

The stratified silts and clays between 3 and 7 m [Zone A in Fig. 13(a)] were found to be the only part of the subsurface profile below Site I that met both CPT conditions that render a soil liquefiable according to Youd et al. (2001) [i.e.,  $I_c < 2.6$  and  $(q_{c1N})_{cs} < 160$ ]. Soil samples show that some lenses have  $LL < 35$  and  $w_c/LL > 0.9$ , but in general the soils have  $30 < LL < 40$ . Fig. 13(b) indicates that over the depth of 3–7 m the tip resistance corresponding to the threshold of liquefaction for free-field PGAs of 0.35 and 0.45 g is generally greater than the measured tip resistances, even after correcting for thin layers. Therefore those layers in Zone A that have values of  $I_c < 2.6$  with  $LL < 35$  and  $w_c/LL > 0.9$  that also have low penetration resistances most likely liquefied during the Kocaeli earthquake. The soils between depths of 3 and 4.6 m had the lowest factor of safety against liquefaction and are therefore judged to be the critical layer (see Fig. 12). Conversely, the stratum of gray poorly graded sand [Zone B in Fig. 13(a)] has a penetration resistance characterized by  $q_{c1N} > 160$  and  $(N_1)_{60-cs} > 30$  and should not have liquefied.

### Discussion

In contrast to Sites C and F, where shallow loose silt deposits immediately below the building foundations were largely responsible for the occurrence of ground failure with buildings sliding laterally, these shallow liquefiable soil deposits were absent at Site I. The nearly vertical movement experienced by these buildings appears to be primarily due to the liquefaction and softening of strata between 3 and 7 m and subsequent downward movement of relatively heavy buildings into the softened soil or postearthquake induced liquefaction settlement. Consistent with the findings of Sancio et al. (2002) in the Adapazari silts, but inconsistent with findings by Yoshimi and Tokimatsu (1977) in studies involving generally clean sands, a clear relationship between building height or weight and the amount of observed downward displacement was not apparent. At Site I, the taller buildings settled less than the shorter building, indicating that other factors possibly related to variations in subsurface condi-

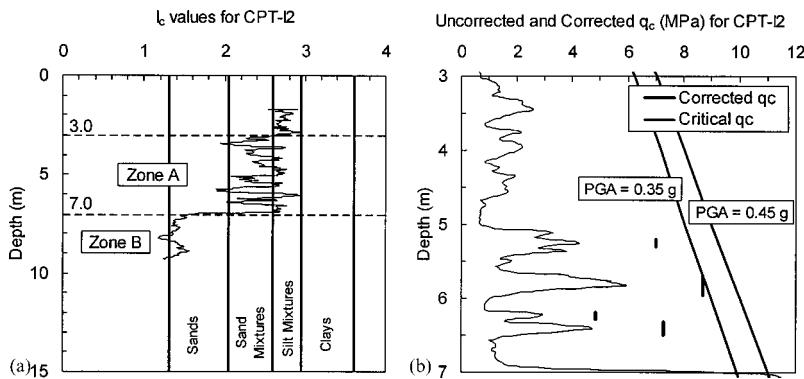

**Fig. 13.** (a) Soil behavior index ( $I_c$ ) values for CPT-I2, and (b) thin layer corrected  $q_c$  and critical  $q_c$  for free-field acceleration of 0.35 and 0.45g versus depth for CPT-I2

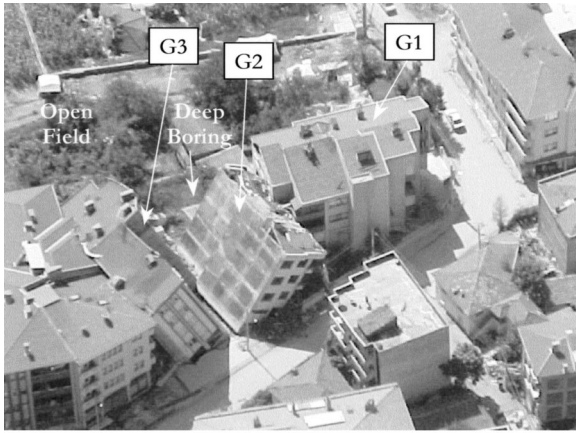

Fig. 14. Aerial view of Site G 13 days after the Kocaeli earthquake

tions, variations in building use, and the influence of adjacent buildings may be important variables to consider in the development of these types of correlations.

### Illustrative Case History of Building Site G

#### Observations

The group of Site G buildings shown in Fig. 14 is located in Yenigün District, Adapazari (N40.77450° E30.40896°), which is only 350 m north of Site F. The irregularly shaped building G1 has a length (E-W) of 22.2 m, a width (N-S) of 14.1 m, and a height of 11.2 m, with a height-to-width ratio of 0.8. This building experienced vertical movement of approximately 10 cm with no significant tilting and suffered light damage aside from that caused by the impact of building G2. The adjacent 4 and 5 story buildings (designated G2 and G3, respectively) experienced bearing capacity type failures with excessive tilt. These buildings have been demolished. According to building drawings, building G3 was 21.7 m long with its width varying between 8.6 and 6.2 m. The structure was 14 m high, so its maximum height-to-width ratio was 2.3. The mat foundation of these buildings consists of 25- to 30-cm-thick reinforced concrete slabs with 1–1.2-m-deep tie-beams. The ground immediately surrounding these buildings was littered with brown sediment ejecta, which were classified as

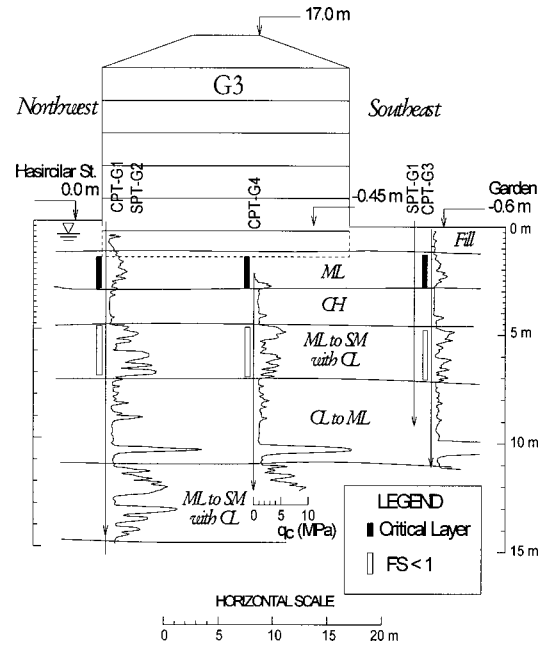

Fig. 15. Northwest to southeast generalized subsurface profile of Site G

low plasticity (LL~30) silty sand (SM). Sand boils were not observed away from the buildings, i.e., in the open field to their rear (see Fig. 14).

#### Site Investigations

A total of four CPT profiles, two borings with SPT, and one very deep boring were performed at this site. The upper 15 m of the generalized subsurface profile of this site is depicted in Fig. 15. The first 1.5 m below the sidewalk level consist of clayey soil followed by approximately 1.5 m of loose [ $(N_1)_{60} < 10$ ] to medium dense reddish brown sandy clayey silt. The soil samples of this deposit generally exhibit  $LL < 35$  and  $w_c/LL > 0.9$ . The brown sediment ejecta identified during the postearthquake reconnaissance appear to have originated in this stratum based on color and LL similarity. The depth to the water table was found to fluctuate between 0.4 and 0.6 m below the sidewalk level.

From approximately 3–5 m the soil transitions from brown clayey silt to gray high plasticity silty clay. Between approxi-

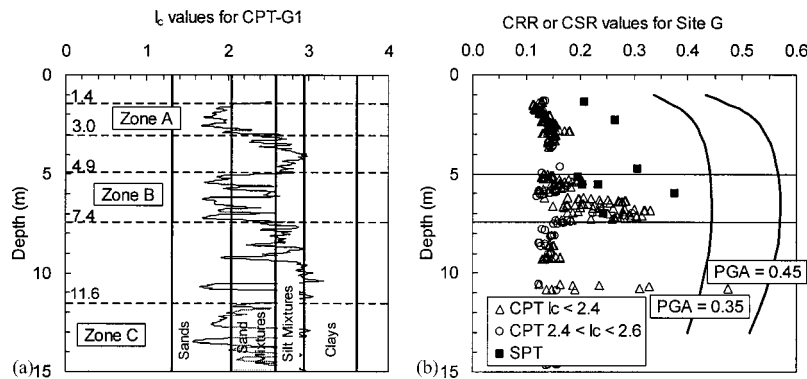
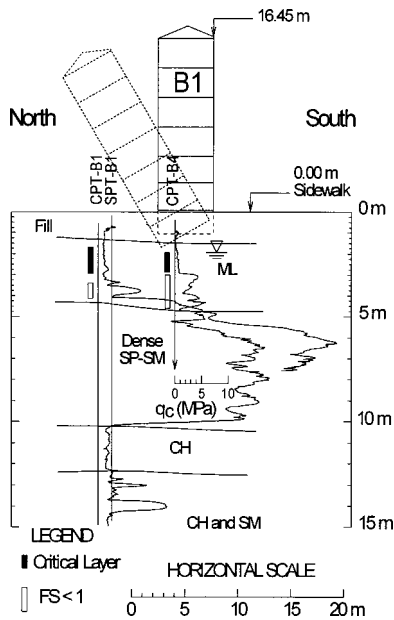

Fig. 16. Representative soil data for Site G: (a) Soil behavior index ( $I_c$ ) values for CPT-G1, and (b) cyclic stress ratio (CSR) induced by earthquake versus depth for peak ground acceleration (PGA)=0.35g and 0.45g compared with the cyclic resistance ratio (CRR) of the soil



**Fig. 17.** Soil profile at Site B where a tall slender building failed in bearing

mately 5 and 7.4 m lies a medium dense gray low plasticity silt grading to silty sand interbedded with thin strata of clayey silt. The fines content of the soils in this deposit varies (22% < FC < 100%) and most samples have LL < 35. A thick deposit of gray silty clay to clayey silt with 36 < LL < 58, but predominantly LL > 50, lying approximately between 7.4 and 11.3 m, was found overlying sequences of medium dense to dense silt and sand mixtures interbedded with silty clay and clayey silts down to 25 m.

### Liquefaction Evaluation

Fig. 16 shows values of  $I_c$  in a representative sounding CPT-G1, as well as a comparison of CRR and CSR values for Site G. As can be observed, the subsurface conditions beneath this site are remarkably similar to the conditions under Site F (see Fig. 10). The liquefaction evaluation of the soils at Site G is similar to that at Site F and is not discussed further for brevity. However, the liquefaction evaluation is summarized in Fig. 15 by showing layers with  $FS_f < 1$  and the critical layer.

### Discussion

Although all buildings seem to have a similar subsurface soil profile, foundation type, and embedment depth, the shape of the structure appears to have had a significant effect on their individual performance. Low aspect ratio building G1 settled only slightly, which allowed the apartment owners to reinhabit it after repairing the damage caused by the adjacent overturned building G2. High aspect ratio buildings G2 and G3 experienced bearing failure, and were later demolished.

The brown silty soils located in the upper 3 m (Zone A) was judged to be primarily responsible for the bearing failure experienced by buildings G2 and G3. At a number of sites where the potentially liquefiable soils at depths of about 5–7.5 m (Zone B) at Site G were replaced with a dense coarse sand that was non-liquefiable (e.g., Site B; profile shown in Fig. 17), bearing capacity failures occurred. Thus softening of the lower Zone B soils is not required to produce a bearing capacity failure for a tall slender

**Table 2.** Characteristics of Critical Soil Layers at Building Sites in Adapazari

Site	Ground failure observed	Critical layer depth (m)	Water depth (m)	USCS	Fines content (%)	LL	PI	$w_c/LL$	Amount particles $\leq 5 \mu\text{m}$ (%)	$N_{60}$ (blows/30 cm)	$C_N$	Mean $q_c$ (MPa)	Standard deviation $q_c$ (MPa)	Mean $f_s$ (MPa)	Standard deviation $f_s$ (MPa)	CSR (PGA = 0.4g)
A	Yes	4.2–5.0	0.75	ML	75–80	27–36	0–11	0.9–1.0	16–29	4–5	1.6	1.33	0.25	0.0151	0.0052	0.46
B1	Yes	1.7–2.9	1.8	ML	80–95	31–37	0–9	0.9–1.0	8	3	1.7	2.40	0.13	0.0073	0.0013	0.29
C1/C2	Yes	1.6–2.4	1.4	ML	60–90	23–32	0–9	1.0–1.2	14–25	2	1.7	2.30	1.02	0.0091	0.0055	0.31
C3	No	3.4–4.4	1.4	ML/CL	90–100	34–36	8–9	1.0	18–32	8	1.5	2.97	0.77	0.0333	0.0133	0.39
D	Yes	1.4–4.0	1.7	ML/CL	50–95	25–35	0–12	0.9–1.1	6–30	3–4	1.7	2.29	0.46	0.0096	0.0071	0.32
E	Yes	2.0–3.4	0.5	ML	60–95	28–33	0	1.0–1.2	22–28	3–5	1.7	1.50	0.17	0.0106	0.0032	0.46
F	Yes	1.5–3.2	1.9	ML	60–90	22–33	0–9	0.9–1.2	11–22	4	1.7	2.02	0.70	0.0080	0.0053	0.31
G	Yes	1.4–3.0	0.6	ML	65–80	26–32	0–5	1.0–1.2	9–14	4–6	1.7	1.63	0.21	0.0056	0.0021	0.40
H	Yes	2.0–2.8	1.7	SM	15	—	—	—	—	11	1.7	3.29	0.88	0.0135	0.0045	0.30
I	Yes	3.0–4.6	0.8	ML	60–80	28–31	0–8	1.0	20	4	1.6	2.09	0.49	0.0149	0.0050	0.44
J	Yes	1.3–3.3	0.7	ML/CL	55–90	24–33	0–10	0.9–1.1	8–26	2–8	1.7	1.86	0.40	0.0115	0.0066	0.41
K	Yes	2.4–3.4	0.8	ML	85	35	9	1.0	29	4–5	1.7	2.12	0.59	0.0133	0.0046	0.42
L	Yes	2.0–3.2	0.7	ML	75–80	26–28	0	1.1	—	4–5	1.7	1.87	0.30	0.0089	0.0035	0.42

Note: USCS = Unified Soil Classification System; LL = liquid limit; PI = plasticity index; CSR = cyclic stress ratio; ML/CL = low compressible silt; ML/CL = low compressible silt with some low compressible clay; SM = silty sand; and CPT = cone penetration test. The CPT tip resistance and sleeve friction were measured at 2 cm intervals and then averaged over a 30 cm thickness. At Site B1, a thin-layer correction of 1.5 was applied, because the critical layer was only 20 cm thick. At Site C3, a thick layer of CH caps the liquefiable silt, which may have prevented ground failure.

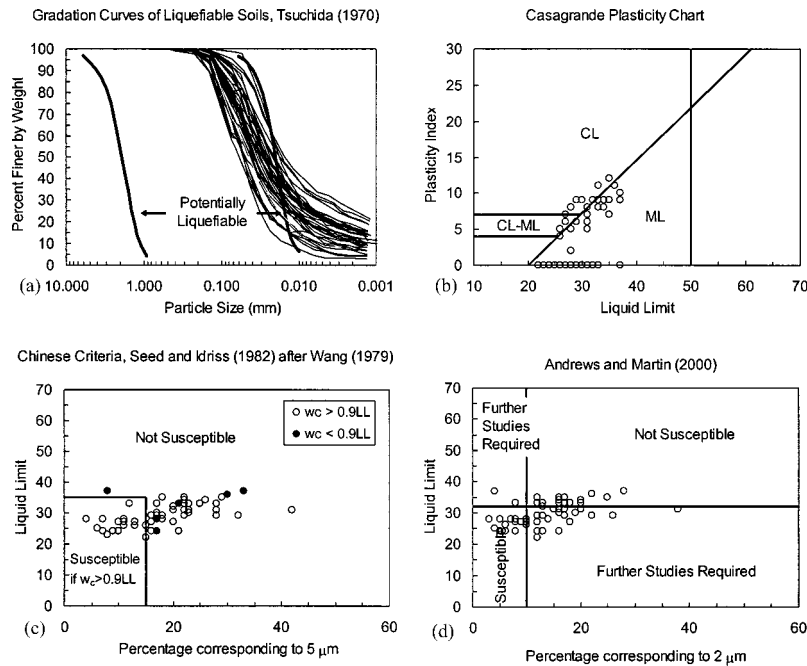

**Fig. 18.** Characteristics of liquefiable soils in Adapazari: (a) grain size distributions; (b) plasticity chart; (c) Chinese criteria for liquefaction of clayey soils after Seed and Idriss (1982) (after Wang 1979); and (d) liquefaction criteria for silty soils after Andrews and Martin (2000)

building overlying shallow deposits of loose silt that liquefy. However, the vertical displacement experienced by all the buildings at Site G may have been due to the combined effect of liquefaction and softening of the soils corresponding to both Zone A and Zone B soils.

### Lessons Learned and Key Implications

Widespread ground failure in Adapazari during the 1999 Kocaeli earthquake severely impacted building performance. Hundreds of structures settled, slid, tilted, and collapsed due in part to liquefaction and ground softening. The soils that led to severe building damage were generally shallow low plasticity silts. Because the seismic response of silty soils is less well understood, well-documented cases of ground failure and its resulting effect on building performance in Adapazari are critically important. Fieldwork that includes CPT profiling and borings with SPTs has been undertaken to characterize the subsurface conditions in Adapazari at a number of building sites and along lines surveyed through the city (Bray et al. 2001b). The CPT was shown to be critical in identifying thin seams of potentially liquefiable soils. However, due to the fine-grained nature of many of the strata in Adapazari, adjacent exploratory borings with carefully performed SPTs were required. Reliable SPT ( $N_1$ )<sub>60</sub> values were obtained by performing SPTs in accordance with established ASTM standards and recording the energy delivered to the sampling system.

In Table 2, the characteristics of the critical soil layers in terms of liquefaction triggering at the 12 building sites investigated in Adapazari are summarized. The data points for these critical soil layers are shown on the CSR versus ( $N_1$ )<sub>60</sub> plot in Fig. 3, which was presented previously. The soil characteristics data that forms the basis for the critical soil layers described in Table 2 are plotted in Fig. 18. Soils that liquefied in Adapazari often contain grain size distributions outside of that commonly believed to be susceptible to liquefaction [Fig. 18(a)]. The Adapazari soils contain a

significant amount of clay-size particles, yet they liquefied. Moreover, many of these soils have significant plasticity [Fig. 18(b)]. The soil index data for these soils that liquefied are also plotted in Fig. 18(c) to allow evaluation of the robustness of the Chinese criteria. Only a few of the soils tested satisfy all conditions of the Chinese criteria. For the silts of Adapazari, low liquid limits ( $\leq 35$  or so) and high water contents ( $w_c \geq 0.9$  LL or so) are good indicators of liquefaction or significant strength loss due to shaking, as shown in Fig. 18(c) and Table 2. The percent clay fraction criterion is not a reliable screening tool, because many cases of ground failure occurred in soils that had more than 15% clay-size ( $5 \mu\text{m}$ ) particles. An examination of the Andrews and Martin (2000) liquefaction criteria for silty soils [Fig. 18(d)] also indicates that the percent clay-size ( $< 2 \mu\text{m}$ ) criterion is not a reliable indicator of liquefaction susceptibility, and that soils with LL  $> 32$  can liquefy.

Liquefaction did occur in Adapazari, but the softening of fine-grained soils due to cyclic mobility and the working of buildings into the softened soils under these buildings was more prevalent. The liquefaction triggering analyses described in this paper were performed for free-field, level ground conditions. Adjustments for the potentially compensating effects of building (e.g.,  $K_\sigma$  and  $K_\alpha$  effects) appear to be dominated by the weakening effect of the increased overburden stress under buildings (i.e., lower  $K_\sigma$  values). It also appears that the static and inertial loading of the reinforced concrete structures was largely detrimental. Hence ground failure was systematically found adjacent to structures and found to be less prevalent away from structures. Ongoing studies are evaluating soil–structure interaction effects, and the role building response had on ground failure.

### Acknowledgments

Financial support was provided by the National Science Foundation under Grants CMS-9987829, CMS-0085130, and CMS-

0116006, by the California Department of Transportation, California Energy Commission, and Pacific Gas and Electric Company through the Pacific Earthquake Engineering Research Center's Lifelines Program under Award number 3A01, and by the David and Lucile Packard Foundation. In-kind support was provided by ZETAS Corporation through the CPT and drilling effort and by Sakarya University through the laboratory-testing program. Other support, such as housing, was provided at numerous times by our Turkish colleagues, and this and all support received are greatly appreciated. Professor Boulanger of U.C. Davis recommended several useful modifications to the paper, and the assistance of three anonymous reviewers is gratefully acknowledged.

## References

- Abou-Matar, H., and Goble, G. (1997). "SPT dynamic analysis and measurements." *J. Geotech. Geoenviron. Eng.*, 123(10), 921–928.
- Ambraseys, N., and Zatopek, A. (1969). "The Mudurnu Valley earthquake of July 22nd, 1967." *Bull. Seismol. Soc. Am.*, 59(2), 521–589.
- Andrews, D. C. A., and Martin, G. R. (2000). "Criteria for liquefaction of silty soils." *Proc., 12th World Conf. on Earthquake Engineering*, New Zealand, Paper No. 0312.
- American Society for Testing and Materials (ASTM). (2000a). "Standard practice for determining the normalized penetration resistance of sands for evaluation of liquefaction potential." *ASTM D 6066-96*, Annual Book of ASTM Standards, Vol. 04.09.
- American Society for Testing and Materials (ASTM). (2000b). "Standard test method for penetration test and split-barrel sampling of soils." *ASTM D 1586-99*, Annual Book of ASTM Standards, Vol. 04.08.
- Bray, J. D., and Stewart, J. P., coordinators. (2000). "Damage patterns and foundation performance in Adapazari." Kocaeli, Turkey Earthquake of August 17, 1999 Reconnaissance Report, T. L. Youd, J. P. Bardet, and J. D. Bray, eds., *Earthquake Spectra*, Supplement A to Vol. 16 163–189.
- Bray, J. D. et al. (2001a). "Ground failure in Adapazari, Turkey." *Proc., Earthquake Geotechnical Engineering Satellite Conf. XVth Int. Conf. on Soil Mechanics & Geotechnical Engineering*, Istanbul, Turkey.
- Bray, J. D., et al. (2001b). "Documenting incidents of ground failure resulting from the August 17, 1999 Kocaeli, Turkey Earthquake." Pacific Earthquake Engineering Research Center website: (<http://peer.berkeley.edu/turkey/adapazari/>).
- Bray, J. D., Sancio, R. B., Riemer, M. F., and Durgunoglu, T. (2004). "Liquefaction susceptibility of fine-grained soils." *11th Int. Conf. on Soil Dynamics and Earthquake Engineering and 3rd Int. Conf. on Earthquake Geotechnical Engineering*, Berkeley, Calif.
- Cox, B. R. (2001). "Shear wave velocity profiles at sites liquefied by the 1999 Kocaeli, Turkey Earthquake." Thesis submitted in partial fulfillment of the requirements for the degree of MS, Utah State Univ., Logan, Utah.
- Hynes, M. E., and Olsen, R. S. (1999). "Influence of confining stress on liquefaction resistance." *Proc., Int. Workshop on Physics and Mechanics of Soil Liquefaction*, Balkema, Rotterdam, The Netherlands, 145–152.
- Idriss, I. M., and Sun, J. L. (1992). *User's manual for SHAKE91*, Center for Geotechnical Modeling, Department of Civil and Environmental Engineering, Univ. of California at Davis, Davis, Calif.
- Kovacs, W. D., and Salomone, L. A. (1982). "SPT hammer energy measurement." *J. Geotech. Eng. Div., Am. Soc. Civ. Eng.*, 108(4), 599–620.
- Lunne, T., Robertson, P. K., and Powell, J. J. M. (1997). *Cone penetration testing*, Blackie Academic Professional, London.
- Onalp, A., Arel, E., and Bol, E. (2001). "A general assessment of the effects of 1999 earthquake on the soil-structure interaction in Adapazari." *Jubilee Papers in Honor of Prof. Ergun Togrul*, 10, ICSEME, Istanbul, Turkey.
- Rathje, E. M., Stokoe, K. H., and Rosenblad, B. (2003). "Strong motion station characterization and site effects during the 1999 earthquakes in Turkey." *Earthquake Spectra*, 19(3), 653–675.
- Robertson, P. K., and Wride, C. E. (1998). "Evaluating cyclic liquefaction potential using the cone penetration test." *Can. Geotech. J.*, 35(3), 442–459.
- Rollins, K. M., and Seed, H. B. (1990). "Influence of buildings on potential liquefaction damage." *J. Geotech. Eng.*, 116(2), 165–185.
- Sancio, R. B. (2003). "Ground failure and building performance in Adapazari, Turkey." PhD thesis, Univ. of California at Berkeley, Berkeley, Calif.
- Sancio, R. B., et al. (2002). "Correlation between ground failure and soil conditions in Adapazari, Turkey." *Soil Dyn. Earthquake Eng.*, 22, 1093–1102.
- Seed, H. B., and Idriss, I. M. (1982). *Ground motions and soil liquefaction during earthquakes*, EERI Monograph, Berkeley, Calif.
- Seed, H. B., Tokimatsu, K., Harder, L. F., and Chung, R. M. (1985). "Influence of SPT procedures in soil liquefaction resistance evaluation." *J. Geotech. Eng.*, 111(12), 1425–1445.
- Skempton, A. W. (1986). "Standard penetration test procedures and the effects in sands of overburden pressure, relative density, particle size, ageing and overconsolidation." *Geotechnique*, 36(3), 425–447.
- Wang, W. (1979). *Some findings in soil liquefaction*, Water Conservancy and Hydroelectric Power Scientific Research Institute, Beijing, China.
- Yoshimi, Y., and Tokimatsu, K. (1977). "Settlement of buildings on saturated sand during earthquakes." *Soils Found.*, 17(1), 23–38.
- Youd, T. L., et al. (2001). "Liquefaction resistance of soils: Summary report from the 1996 NCEER and 1998 NCEER/NSF workshops on evaluation of liquefaction resistance of soils." *J. Geotech. Geoenviron. Eng.*, 127(10), 817–833.