

REFERENCES

- Anderson, L. & Plaut, W. G. E. (1949). In *Respiratory Enzymes*, p. 71. Ed. by Lardy, H. A. Minneapolis, U.S.A.: Burgess Publishing Co.
- Avis, P. G., Bergel, F. & Bray, R. C. (1955). *J. chem. Soc.* p. 1100.
- Avis, P. G., Bergel, F., Bray, R. C., James, D. W. F. & Shooter, K. V. (1956*a*). *J. chem. Soc.* p. 1212.
- Avis, P. G., Bergel, F. & Bray, R. C. (1956*b*). *J. chem. Soc.* p. 1219.
- Beinert, H. & Sands, R. H. (1959). *Biochem. biophys. Res. Commun.* **1**, 171.
- Beinert, H. & Sands, R. H. (1960). *Biochem. biophys. Res. Commun.* **3**, 41.
- Bergel, F. & Bray, R. C. (1958). *Symp. biochem. Soc.* **15**, 64.
- Bleaney, B. & Ingram, D. J. E. (1952). *Proc. phys. Soc., Lond.*, A **65**, 953.
- Bowers, K. D. & Owen, J. (1955). *Rep. Progr. Phys.* **18**, 304.
- Bray, R. C. (1959). *Biochem. J.* **73**, 690.
- Bray, R. C. (1961). *Biochem. J.* **81**, 196.
- Bray, R. C., Malmström, B. G. & Vänngård, T. (1959). *Biochem. J.* **73**, 193.
- Gibson, J. F., Ingram, D. J. E. & Schonland, D. (1958). *Disc. Faraday Soc.* **26**, 72.
- Gutfreund, H. & Sturtevant, J. M. (1959). *Biochem. J.* **73**, 1.
- Haddow, A., de Lamirande, G., Bergel, F., Bray, R. C. & Gilbert, D. A. (1958). *Nature, Lond.*, **182**, 1144.
- Hollocher, T. C. & Commoner, B. (1960). *Proc. nat. Acad. Sci., Wash.*, **46**, 416.
- Larson, M. L. (1960). *J. Amer. chem. Soc.* **82**, 1223.
- Malmström, B. G. & Vänngård, T. (1960). *J. molec. Biol.* **2**, 118.
- Michaelis, L. & Schubert, M. P. (1938). *Chem. Rev.* **22**, 437.
- Morell, D. B. (1952). *Biochem. J.* **51**, 657.
- Perrin, D. D. (1958). *J. Amer. chem. Soc.* **80**, 3540.
- Sacconi, L. & Cini, R. (1954). *J. Amer. chem. Soc.* **76**, 4239.
- Sands, R. H. & Beinert, H. (1960). *Biochem. biophys. Res. Commun.* **3**, 47.
- Selwood, P. W. (1956). *Magnetochemistry*. New York: Interscience Publishers Inc.
- Theorell, H. & Ehrenberg, A. (1951). *Ark. Fys.* **3**, 299.
- Totter, J. R. & Comar, C. C. (1956). In *Inorganic Nitrogen Metabolism*, p. 513. Ed. by McElroy, W. D. & Glass, B. Baltimore: The Johns Hopkins Press.
- Vänngård, T., Bray, R. C., Malmström, B. G. & Pettersson, R. (1961). In *Symp. Free Radicals in Biological Systems*, p. 209. New York: Academic Press Inc.
- Weissman, S. I. & Cohn, M. (1957). *J. chem. Phys.* **27**, 1440.
- Whitby, L. G. (1953). *Biochem. J.* **54**, 437.

Biochem. J. (1961) **81**, 189

Sudden Freezing as a Technique for the Study of Rapid Reactions

BY R. C. BRAY

Chester Beatty Research Institute (Institute of Cancer Research: Royal Cancer Hospital), Fulham Road, London, S.W. 3

(Received 9 January 1961)

The kinetics of reactions in solution, having half-reaction times in the range of a few seconds down to 1 msec., are frequently studied by continuous-, stopped- or accelerated-flow methods. The 'quenching' method has been less widely used and differs from these methods in that the extent of reaction is measured at leisure on a series of samples taken from the streaming solution and 'fixed', by stopping the reaction after appropriate time intervals (Roughton & Chance, 1953). The essential requirement of this method is a quenching process which is rapid compared with the reaction being studied. Chemical quenching, in which the reaction is stopped by introducing a reagent that arrests the reaction at an appropriate point in the stream, has found limited application, but the principle of stopping a fast reaction by sudden cooling does not appear to have been considered. In this paper some of the conditions necessary for the application of

what may be termed the 'thermal quenching' method are discussed and a suitable apparatus is described. The usefulness of the method is limited by the availability of procedures for determining the extent to which the reaction has proceeded in the frozen samples. It was devised for use in conjunction with electron-spin-resonance measurements, which are in any case frequently made on frozen samples (see Addendum). The method has also proved suitable for the semiquantitative study of reactions involving colour changes.

Principle of the technique

Effect of cooling on reaction velocity. The technique depends on obtaining a series of samples of a mixture in which the reaction has been allowed to proceed for controlled periods and then stopped by suitable cooling. For a reaction dependent on molecular collisions and with a half-time of

100 msec., freezing within 10 msec. and holding the samples just below the freezing point until they had been examined would presumably be effective. However, intramolecular rearrangements might continue in the frozen state; e.g., with a constant temperature coefficient of 2 per 10° and a half-time of 100 msec. at 20° , the half-times would be about 2 min., 2 hr. and 2 days at temperatures of -80° , -140° and -190° respectively. It would therefore be necessary to cool the frozen samples from such reactions further, if possible to the temperature of liquid nitrogen, with little delay to obtain effective quenching.

Method of cooling. The most suitable method of cooling the solution appeared to be to squirt it through a narrow jet into an immiscible liquid maintained at as low a temperature as possible. This was preferred to squirting directly into liquid nitrogen (or into any liquid with a boiling point below the temperature of the reaction solution), since gasification of the coolant would retard heat transfer. The order of magnitude of time required to freeze, for example, a dilute aqueous solution at 20° squirted into hexane at -80° may be obtained by assuming that the water enters the hexane as a cylindrical stream with a diameter equal to the bore of the jet. If there is a large excess of hexane, and if sufficient turbulence is set up to maintain the surface of the water near to -80° throughout the freezing process, then the freezing time will depend solely on heat transfer through the water. Calculations based on these assumptions indicate that the freezing time goes up in proportion to the square of the bore of the jet and is about 10 msec. for a bore of 0.2 mm. The freezing time would be longer if air were carried into the hexane with the water, since this would delay the liquids' coming into contact with each other. The time would be shorter if the water broke up into smaller drops. It was concluded that solutions should be squirted through as narrow a jet as was practical, a theoretical upper limit for the bore being about 0.2 mm.

Method of driving the liquids. In order to conserve the solutions that are interacting, the flow of the liquids should be accelerated very rapidly to a predetermined value, maintained there until a sample large enough for measurement has been collected (this took a time of the order of 1 sec. in the final form of the apparatus) and then the flow stopped, again very rapidly; thus each sample would be essentially homogeneous with regard to the time that elapsed between mixing the solutions and freezing. This was achieved by driving the liquids from syringes by means of a constant-speed hydraulic ram. This type of apparatus is mentioned by Roughton & Chance (1953), but no details are given. The hydraulic pressure likely to be reached in the flowing liquid was calculated to

be of the order of 10 atm. and the force required to drive the plungers of the syringes of the order of 3 kg. wt. If the hydraulic ram driving the plungers is not to be slowed down significantly by the syringes, it must be capable of delivering at least 10 times this force.

Details of the apparatus

The apparatus consisted of the following components: (i) the hydraulic ram unit; (ii) the syringes and reaction unit; (iii) the ram-velocity indicator. These were all mounted on a heavy steel base (Fig. 1).

Hydraulic ram unit. The ram *D* had a bore of 6 cm. and was mounted horizontally. It was connected via a magnetically operated valve *C* and a needle valve *B* to the bottom of a pressure vessel *A*. The vessel had a capacity of approx. 2 l. and was fitted at the top with a pressure gauge and two needle valves, one of which could be connected to a source of compressed air and the other to a vacuum pump. The pressure vessel was about one-third filled with aqueous glycerol (viscosity 8 centipoises) or, for some experiments, with methanol, which served as the hydraulic fluid. To operate the ram, the magnetic valve was closed and the lower needle valve *B* was opened to a suitable extent. Pressure (4 atm. for most experiments) was then applied to the vessel and the top valves were closed; on opening the magnetic valve, the ram moved forward at a virtually constant velocity. This velocity was controlled by varying the setting of the lower needle valve. The ram could be withdrawn by applying suction to the pressure vessel.

The operating end of the ram was fitted with two adjustable screw pieces *E* to bear on the syringe plunger heads and with a guide to prevent rotation of the ram. The travel of the ram was limited by means of a heavy adjustable screw-stop *F*. The stroke was terminated when the operating end of the ram hit this stop.

Syringes and reaction unit. This part of the apparatus is shown in Fig. 2. All-glass syringes were originally employed, but proved unsatisfactory for delivering concentrated protein solutions, since denaturation on the ground-glass surfaces caused the syringes to jam. They were therefore replaced by specially constructed syringes with Perspex barrels (3–6 mm. bore) and Teflon plungers. The connecting, reaction and jet tubes were 0.5 mm. bore polythene tubing with a wall thickness of 0.5 mm. The mixing chamber *H* was made by drilling three 0.5 mm. holes to meet at a point in a block of Perspex. (Slight imperfections in the drilling would improve the efficiency of mixing.) A number of interchangeable reaction tubes *K* with lengths varying from 10 to 90 cm. were used with the apparatus. Details of the connectors are shown in Fig. 3. Flanges of the shape illustrated could be made simply by heating the ends of the polythene tubes over a small electric radiant heater. Drilled-out stainless-steel screws going into tapped holes in the Perspex block served to press the polythene flanges firmly against the Perspex block. Thus no metal parts came into contact with the solutions. The jet *I* was made by drawing out a piece of polythene tubing over the electric heater. A certain amount of practice was required for this, and a satisfactory shape is shown in Fig. 4. Although the syringes were arranged horizontally, the jet actually pointed vertically downwards (i.e. into the plane of the paper in Fig. 2). For runs at the shortest possible

reaction time, the jet tube was connected directly to the mixing chamber.

Ram-velocity indicator. As the ram approached its stop *F*, a microswitch attached to it first closed and then opened a circuit which allowed a condenser to be charged up from a fixed-voltage source. The arrangement was such that the circuit closed when the ram was 9 mm. from the stop and opened again when there was 3 mm. of travel left. After the run, the voltage on the condenser was measured by switching it to a high-resistance internal-reflecting galvanometer. The condenser was normally charged to a potential low compared with the applied voltage; hence there was a linear relationship between the reciprocal of the galvanometer reading and the ram velocity. To calibrate the timer, the ram velocity was also measured directly, under suitable conditions, with a stop-watch.

In order to calculate the time interval corresponding to passage of a small portion of the solution from the mixing chamber to the jet, it was necessary to know the volumes of the reaction tubes and the jet tubes. These were conveniently determined by weighing each tube empty and full of water. The time *t* (msec.) could then be calculated from the equation $t = w/V\Delta$, where *V* is the ram velocity (cm./sec.), *A* is the total cross-sectional area (cm.²) of the two syringes and *w* is the weight (mg.) of water required to fill the reaction tube and jet. (The amounts of water in the mixing-chamber block and the block connecting the reaction tube to the jet were relatively small, and were ignored.)

Cooling methods. Two procedures were used. In the first, the reaction solution was squirted into hexane (m.p. -100°, b.p. +70°) or light petroleum (b.p. 60-80°) cooled

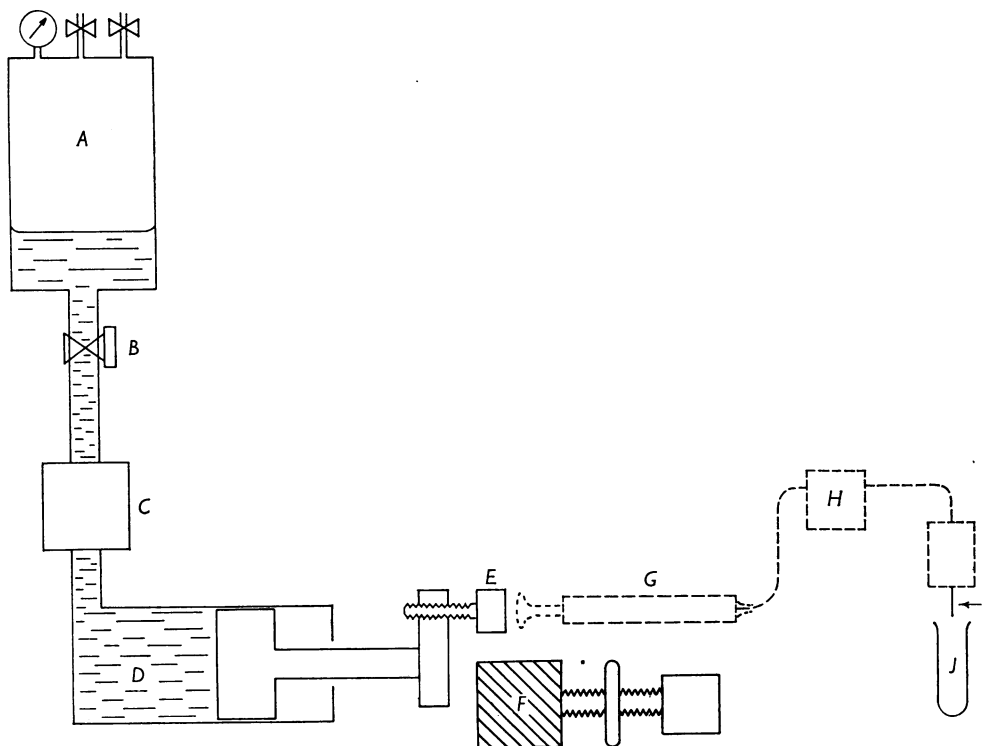

Fig. 1. Hydraulic system and general layout. *A*, Pressure vessel; *B*, needle valve; *C*, magnetic valve; *D*, hydraulic ram; *E*, adjustable screws bearing on syringe plunger heads; *F*, adjustable ram stop; *G*, syringes (the second is behind the first); *H*, mixing chamber; *I*, jet; *J*, container of cold liquid.

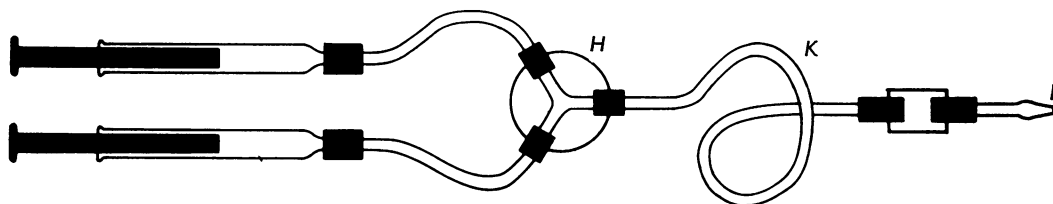

Fig. 2. Syringes and reaction unit. *H*, Mixing chamber; *I*, jet; *K*, reaction tube.

in solid CO_2 to about -60° . This proved satisfactory for some work, but on theoretical grounds a lower temperature seemed desirable. The second procedure thus consisted of squirting into *isopentane* [m.p. -160° , b.p. $+30^\circ$ (Harris, 1954)] at about -140° ; below this temperature, the liquid became unduly viscous. The temperature of -140° was maintained by means of a bath employing liquid nitrogen as the coolant.

Operating procedure. The syringes were filled, care being taken to avoid bubbles and any debris that might block the jet, and connected to the mixing chamber. The ram was brought slowly up to the syringes so that both screw stops *E* were in contact with the plungers, and the system was filled with the solutions up to the outlet from the reaction chamber. A suitable reaction tube and jet were then connected but left empty, and the ram stop *F* was set so that the required volume of solutions would be delivered. The ram was withdrawn a little way from the plungers (to ensure that it reached its maximum velocity before striking them) and the ram and timer controls were set. Immediately before the magnetic valve *C* was operated to make the run, a suitable container of the cooling liquid *J* was removed from its bath and held in the operator's hand, with the surface of the liquid 1–2 cm. below the jet. Squirting the aqueous solution into the hydrocarbon in this manner caused violent turbulence. The aqueous solution froze apparently instantaneously, to give a suspension of fine ice crystals which settled out within a few seconds. After the run, the container was returned to the cooling bath, and the timer was read.

In any series of experiments a fixed operating pressure and valve-setting were employed, so that the ram velocity was kept constant (or almost so) and the reaction time was varied by interchanging the reaction tubes *K*.

Tests on the apparatus

Flow tests. The ram velocity was fairly uniform and reproducible and relatively independent of the presence of the syringes. The smallest practicable jet had a bore of 0.10 mm.; a size of about 0.14 mm. was used for the quantitative work described below. Suitable flow rates were about 0.2–2.0 ml./sec., corresponding to flow velocities in the 0.5 mm. bore reaction tube of 1–10 m./sec. The lower limit was set by the performance of the ram and the jet and the upper limit by the strength of the polythene tubing. The range of reaction times covered by the apparatus was therefore about 10–1000 m-sec.

The efficiency of mixing chambers similar to the one described was established by Roughton & Chance (1953). The velocity for a change to turbulent flow in the reaction tube was about 4 m./sec. and most runs were carried out at lower velocities.

Tests on a model fast reaction. The reaction $\text{H}_2\text{CO}_3 \rightarrow \text{H}_2\text{O} + \text{CO}_2$ is one that has been used for testing other types of fast-reaction apparatus (Dalziel, 1953; Gibson, 1954). When 0.02 M- NaHCO_3 is mixed with 0.01 M-HCl, the solution is initially acid to bromophenol blue, but as the carbonic acid which is first formed decomposes,

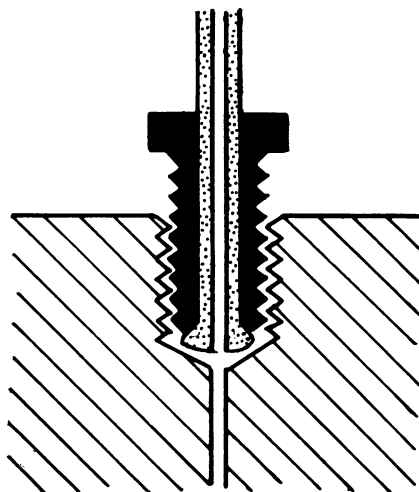

Fig. 3. Method of connecting a flanged polythene tube to a Perspex block.

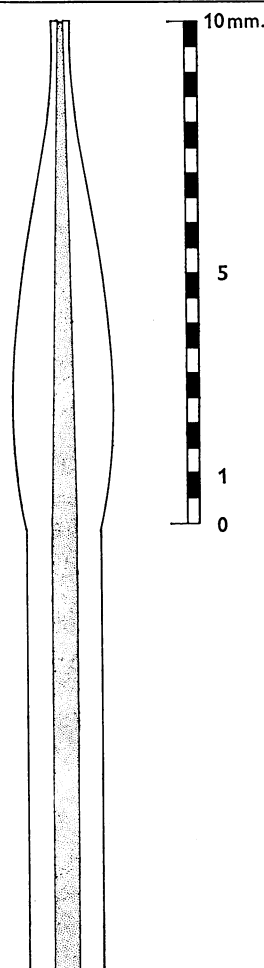

Fig. 4. Details of polythene jet *I* (see Fig. 1).

with a half-life of the order of 100 msec. at room temperature, the solution becomes alkaline to the indicator. Runs were carried out with the above concentrations of HCl and NaHCO₃ in the two syringes and with 0.02% bromophenol blue in each of the reagents (this indicator concentration is considerably higher than that used by the other workers).

Satisfactory results were obtained by using 150 ml. portions of light petroleum (b.p. 60–80°), contained in stoppered vessels and thoroughly cooled in solid CO₂-methanol. Preliminary experiments showed that with short reaction times the crystals were noticeably yellow, whereas with longer times they were bluish purple. On thawing, all the samples became purple. With many shapes of container, a small amount of solution often froze on the bottom rather than as free crystals. This material usually had a somewhat different colour from the bulk of the crystals, and had to be ignored when colour comparisons were made. It probably arose as a result of the petroleum's being stationary when the stream of water first struck it, allowing some of the water to pass straight to the bottom of the container rather than be carried around by the violent motion that ensued. The containers described in the Addendum did not seem to possess this disadvantage.

With the exception noted above the colour within a sample was always homogeneous. This is taken as evidence that in any one run the value of t was constant. Deviations would have been expected if the ram speed was not uniform, if there were air bubbles in the liquids, or if elasticity of the polythene tubing at the rather high operating pressures became a serious factor. When the jet bore was increased from 0.14 to 0.22 mm., which might have the effect of increasing the freezing time, noticeably bluer crystals were obtained.

Finally, an attempt to obtain semiquantitative results was made at 25° with reaction times in the range 20–300 msec. The frozen samples were kept in the bath for periods of 0.5–3 hr., then removed and photographed in colour. Once the samples were thoroughly frozen and cooled, no colour changes were observed. However, it was essential that the photographs were taken as soon as possible after the crystals were removed from the bath, since, apart from the danger of thawing, a reversible intensification of the colours appeared to take place on warming slightly. A series of citrate buffers of known pH containing bromophenol blue

were prepared, and were run in the apparatus and photographed under identical conditions. It was then possible, by visual comparison of the photographs, to determine the pH at each value of t , generally with an estimated error of ± 0.2 pH unit. A graph of pH against t was plotted. Within the rather large limits of experimental error this graph was linear, cutting the $t = 0$ axis at pH 3.8 ± 0.3 and with a slope of 170 ± 40 msec./pH unit. These data are in satisfactory agreement with published work. Thus Dalziel (1953) found an initial pH of 3.5–3.6, whereas Gibson (1954) found 3.7. If 3.6 is assumed to be the correct value, then the time required to stop the reaction in the present work may be calculated to be 30 msec. (limits, 0–90 msec.).

It was therefore concluded that the performance of the apparatus was satisfactory and that at least one fast reaction could be effectively stopped by the cooling procedure described.

SUMMARY

1. Conditions necessary for stopping rapid reactions by squirting aqueous solutions through a fine jet into a cold immiscible liquid are discussed. An apparatus is described which produces homogeneous samples frozen at any desired stage of a reaction occurring in aqueous solution and having a half-life of the order of 100 msec.

The author thanks Professor F. Bergel, F.R.S., Dr B. G. Malmström and Dr T. Vänngård for their interest in and encouragement of this work. He also thanks Mr G. S. Dear for advice on heat transfer, Mr K. N. C. Bray for advice on hydraulic questions and Mr B. Aasa for constructing the -140° thermostat. Most of the constructional work on the apparatus was carried out by Mr J. Weight and Mr A. L. Stewart. The work was supported by grants to the Chester Beatty Research Institute (Institute of Cancer Research: Royal Cancer Hospital) from the Medical Research Council, the British Empire Cancer Campaign, the Jane Coffin Childs Memorial Fund for Medical Research, the Anna Fuller Fund and the National Cancer Institute of the National Institutes of Health, U.S. Public Health Service.

REFERENCES

- Dalziel, K. (1953). *Biochem. J.* **55**, 79.
Gibson, Q. H. (1954). *Proc. Roy. Soc. B*, **143**, 310.
Harris, R. J. C. (1954). *Biological Applications of Freezing and Drying*, p. 329. New York: Academic Press Inc.
Roughton, F. J. W. & Chance, B. (1953). In *Techniques of Organic Chemistry*, vol. 8, p. 669. Ed. by Friess, S. L. & Weissberger, A. New York: Interscience Publishers Inc.

ADDENDUM

Electron-Spin-Resonance Measurements

BY R. C. BRAY* AND R. PETERSSON

Institutes of Biochemistry and Physics, University of Uppsala, Sweden

(Received 9 January 1961)

In order to make measurements of electron-spin-resonance signals on samples frozen by the technique described in the preceding (main) paper it was necessary to pack the ice crystals into tubes suitable for insertion into the cavity of a Varian V 4500 spectrometer. This was achieved by squirting a 0.3–0.5 ml. portion of the reaction mixture into about 40 ml. of cold hexane or isopentane in a silica tube as illustrated in Fig. 1. The tube was returned to the cooling bath immediately after squirting and some of the ice crystals were packed into the bottom by working a packing device (Fig. 2) up and down in the tube, the latter being kept in the cooling bath throughout. A solid mass of crystals about 2 cm. in height was obtained at the bottom; the tube was then removed from the bath and the lower part immersed in liquid nitrogen until the electron-spin-resonance measurements were made. The operations, from squirting to cooling in liquid nitrogen, occupied 2–7 min. The measurements were made at the temperature of liquid nitrogen. The tubes were positioned carefully inside the vacuum flask of the spectrometer with the samples at the centre of the cavity. Comparison of the volumes occupied by the packed ice crystals and the water obtained on thawing indicated that about 60% of the packed volume was ice. This figure was fairly reproducible.

The technique was tested by using as a model reaction the reduction of Fe^{3+} to Fe^{2+} ions by quinol. This reaction has been studied by conventional methods by Baxendale, Hardy & Sutcliffe (1951), and extrapolation of their data suggested that a suitable reaction velocity would be obtained under the conditions set out in Fig. 3. The results in Fig. 3 show that reasonable precision was achieved.

The application of the method to the study of an enzymic reaction is reported by Bray (1961). It is interesting to compare the performance and potentialities, particularly for the study of enzyme intermediates, of the present freezing method with the more conventional continuous- and stopped-flow electron-spin-resonance methods. Continuous-flow methods suitable for examining free radicals arising from the substrate (Chance *et al.* 1961; Yamazaki, Mason & Piette, 1960) or from the

enzyme (Commerer & Hollocher, 1960) have been described, but none of the procedures seem suitable for rapid-reaction work on enzyme intermediates. A stopped-flow method is also described by Yamazaki *et al.* (1960) and, by raising the enzyme concentration, this could in principle be extended to the observation of enzyme, in addition to substrate, free radicals. However, if the time resolution of the electron-spin-resonance spectrometer is reduced to the level necessary for such work, the

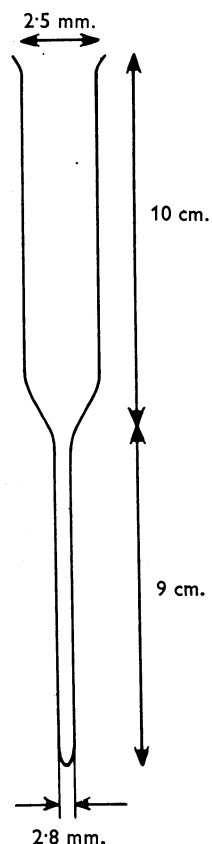

Fig. 1. Silica tubes. The diameters are internal.

* Permanent address: Chester Beatty Research Institute (Institute of Cancer Research: Royal Cancer Hospital), London, S.W. 3.

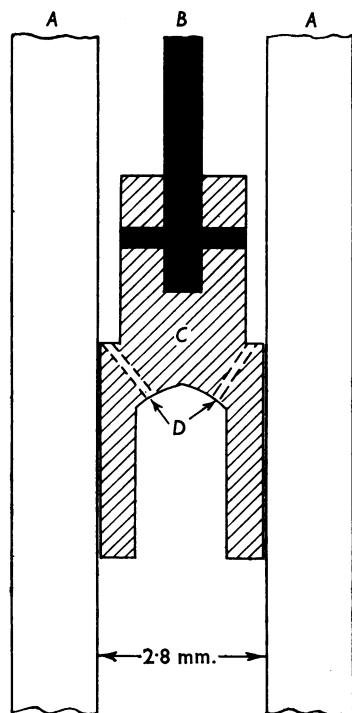

Fig. 2. Section through packing device. A, Lower part of silica tube (Fig. 1); B, stainless-steel rod extending to top of tube; C, Teflon packer, fitting fairly tightly in tube; D, small holes.

signal:noise ratio falls; this means in principle that the faster the reaction, the higher the enzyme concentration required. In fact, in each of the four enzymic reactions studied by Bray (1961), Commoner & Hollocher (1960), Nakamura (1960) and Yamazaki *et al.* (1960), the lowest free-radical concentration reported was of the order of $0.1 \mu\text{M}$. In general, though hyperfine structure may not be apparent in the cold, measurements on frozen aqueous samples give greater sensitivity than do those on unfrozen ones. Hence the present method should be capable of working at lower enzyme concentrations than the stopped-flow method. A further advantage of the freezing procedure is that certain signals which can readily be detected in the cold are not detectable at room temperature, presumably because of the rapid increase in line width (Beinert & Sands, 1960; Bray, Pettersson & Ehrenberg, 1961). The quantity of enzyme solution required to obtain an entire curve in the present procedure was about 2 ml., which is somewhat more than the minimum required for stopped-flow

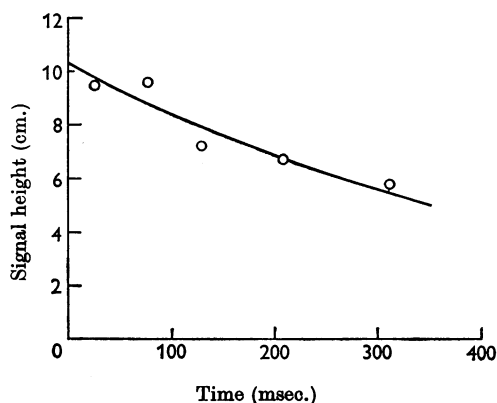

Fig. 3. Rate of decrease of electron-spin-resonance signal in the region of $g = 4$, on mixing a solution containing Fe^{2+} (0.04 g.atom/l. in 0.01 M- HClO_4 containing 0.5 M- NaClO_4) with an equal volume of quinol (0.4 M in the same solvent) at 25° . The reaction was stopped by squirting the solution into hexane at -60° . The curve through the experimental points was calculated for a unimolecular reaction with $k = 2.0 \text{ sec.}^{-1}$

procedures, but very much less than that needed for continuous flow. Further, whereas the stopped-flow procedure has to be carried out successively at a series of fixed field strengths, each corresponding to a particular g , the freezing technique gives a complete electron-spin-resonance spectrum at each reaction time: this may be a considerable advantage where, for instance, new signals are unexpectedly encountered.

We thank the Swedish Natural Science Research Council and the Division of General Medical Sciences, U.S. Public Health Service (RG-6542), for financial support. R.C.B. also thanks the Chester Beatty Research Institute for leave of absence and financial support.

REFERENCES

- Baxendale, J. H., Hardy, H. R. & Sutcliffe, L. H. (1951). *Trans. Faraday Soc.* **47**, 963.
 Beinert, H. & Sands, R. H. (1960). *Biochem. biophys. Res. Commun.* **3**, 41.
 Bray, R. C. (1961). *Biochem. J.* **81**, 196.
 Bray, R. C., Pettersson, R. & Ehrenberg, A. (1961). *Biochem. J.* **81**, 178.
 Chance B., Bicking, L. & Legallais, V. (1961). In *Symp. Free Radicals in Biological Systems*, p. 101. New York: Academic Press Inc.
 Commoner, B. & Hollocher, T. C. (1960). *Proc. nat. Acad. Sci., Wash.*, **46**, 405.
 Nakamura, T. (1960). *Biochem. biophys. Res. Commun.* **2**, 111.
 Yamazaki, I., Mason, H. S. & Piette, L. (1960). *J. biol. Chem.* **235**, 2444.