



Saridis, G., Alexandropoulos, D., Zervas, G., & Simeonidou, D. (2015). Survey and Evaluation of Space Division Multiplexing: From Technologies to Optical Networks. *IEEE Communications Surveys & Tutorials*, 17(4), 2136-2156.
<http://ieeexplore.ieee.org/xpl/articleDetails.jsp?arnumber=7214205&queryText=survey%20and%20evaluation%20of%20space%20division%20multiplexing&newsearch=true>

Peer reviewed version

[Link to publication record in Explore Bristol Research](#)
PDF-document

("(c) 20xx IEEE. Personal use of this material is permitted. Permission from IEEE must be obtained for all other users, including reprinting/ republishing this material for advertising or promotional purposes, creating new collective works for resale or redistribution to servers or lists, or reuse of any copyrighted components of this work in other works.")

© Copyright 2015 IEEE - All rights reserved.

University of Bristol - Explore Bristol Research

General rights

This document is made available in accordance with publisher policies. Please cite only the published version using the reference above. Full terms of use are available:
<http://www.bristol.ac.uk/red/research-policy/pure/user-guides/ebr-terms/>

Survey and Evaluation of Space Division Multiplexing: From Technologies to Optical Networks

George M. Saridis, Dimitris Alexandropoulos, Georgios Zervas, Dimitra Simeonidou

Abstract—Single Mode Fiber’s physical capacity boundaries will soon be reached, so alternative solutions are much needed to overcome the multiplying and remarkably large bandwidth requests. Space division multiplexing (SDM) using multicore fibers (MCF), multi-element fibers (MEF), multimode fibers (MMF) and their combination; few-mode multicore fibers (FM-MCF) or fibers based on orbital angular momentum (OAM), are considered to be the propitious stepping-stones to overcome the capacity crunch of conventional single-core fibers. We critically review research progress on SDM fibers and network components and we introduce two figures of merit (FoM) aiming in quantitative evaluation of technologies such as amplifiers, fan-in/fan-out multiplexers, transmitters, switches, SDM nodes. Results show that SDM fibers achieve an 1185-fold (18-fold) Spectral-Spatial Efficiency increase compared to the 276-SMF bundle (single-core fiber) currently installed on the ground. In addition, an analysis of crosstalk in MCFs shows how SDM concepts can be exploited further to fit in various optical networks, such as core, metro and especially future intra-datacenter optical interconnects. Finally, research challenges and future directions are discussed.

Index Terms—Space Division Multiplexing, Multicore Fibers, Figures of Merit, Spectral-Spatial Efficiency, Components Performance per Footprint Area and Volume, Data-Center Networks, Crosstalk

I. INTRODUCTION

Communications infrastructure, interconnecting anything from servers inside datacenters to people all around the globe, has been evolving constantly during the

last decades towards full optical networks. Indeed optical networks have proven to be the ideal candidate to accommodate the increasing demand for communication until now. However, the introduction of “Big Data”, intense social networking, real-time gaming, High Definition (HD) audio - video streaming and of innumerable other bandwidth-hungry applications, has set the bar of network capacity even higher [1]–[3]. The problem is that the physical capacity limits of the SMF, which is widely used at the moment in all kinds of optical networks, will soon be exhausted [4]. In the early 90’s, Wavelength Division Multiplexing (WDM) together with C-band EDFAs [5] managed to serve the increasing traffic at the time. Today, researchers consider SDM as a sufficient means to override the current capacity crunch [6]. SDM is not a new concept at all, since the idea of having multiple spatial channels (i.e. cores or modes) co-propagating in the same fiber structure dates back in early 80’s [7], [8].

Nowadays, SDM in its simplest form, such as SMFs in a bundle or SMF ribbon cables, is already commercially available. Recent SDM research has focused on fibers supporting multiple cores, multiple elements, few LP modes (the fundamental linear polarized propagation modes of light inside the fiber) or even modes carrying Orbital Angular Momentum (OAM) [9]. Despite the recent extensive SDM research, no single study exists on both quantitatively evaluating these technologies, and correlating network system requirements with SDM technologies performance. As a result, reliable figures of merit along with new metrics for SDM have to be generated.

In section II, the scope of the present contribution is review recent progress in numerous SDM network elements, including state-of-the-art fibers, amplifiers, SDM multiplexers/de-multiplexers (mux/demux), SDM transmitters (Tx), receivers (Rx) and Photonic Integrated Chips (PIC). In section III, two SDM figures of merit (FoM) are introduced. The first one aims to measure Spectral Efficiency (S.E.) per cross-sectional area of the fibers (Spectral-Spatial Efficiency – S.S.E.) with a unit of b/s/Hz/mm² and the second focuses in evaluating optical networks components with regards to their footprint area and their volume. Following these FoMs, a quantitative analysis of the above SDM technologies is presented, evaluating fibers and components with regards to the space dimension. Section IV describes ways of how SDM could

Manuscript received November 14, 2014.

This work is supported by the EPSRC grant EP/I01196X: The Photonics HyperHighway, the ECFP7, grant no. 317999, IDEALIST and grant no. 619572, COSIGN.

George M. Saridis, Georgios Zervas and Dimitra Simeonidou are with the High Performance Networks Group, University of Bristol, Bristol, United Kingdom (George.Saridis@bristol.ac.uk).

Dimitris Alexandropoulos is with the Department of Materials Science, University of Patras, Patra, Greece (dalexa@upatras.gr).

reinforce diverse future optical network types, such as data-centers and metro/core networks, are demonstrated. Furthermore, we critically review other major networking aspects considering SDM network and node concepts and components, such as SDM Reconfigurable Optical Add/Drop Multiplexers (ROADMs), Self-homodyne detection and Multiple Input Multiple Output – Digital Signal Processing (MIMO-DSP) on SDM receivers, routing and core allocation complexity in MCFs as well as multidimensionality and granularity in switching. A study on the inter-core crosstalk interference constraint of MCFs for SDM networks is included. The outcomes of our analysis are specific MCF design rules considering the crosstalk vs fiber core-pitch relation and network link distance with regards to the end application; i.e. 10m to 1km for Intra-DC or tens to hundreds of kilometers for metro/core networks. Different network classes are examined in the light of the outcomes of this analysis, resulting in a complete report on the challenges and the role of SDM in future high-capacity scalable optical networks. Finally, section V discusses challenges, potential use-cases and future directions of SDM.

II. QUALITATIVE REVIEW OF SPACE DIVISION MULTIPLEXING NETWORK COMPONENTS AND TECHNOLOGIES

In this first part of the paper, a summary of available SDM technologies is presented; addressing the pros and the cons of each of them and formulate a vision of how a thorough space division multiplexed networking platform would be in the future. The emphasis in this section is on SDM technologies while Multi-Level (or Advanced) Modulation Formats are considered in certain circumstances. It should be clarified that SDM networking is not achieved only by using SDM point-to-point links, but also by exploiting the space dimension in each of the network parts, including the transmitters, receivers, amplifiers, switches, ROADMs, multiplexers/ demultiplexers.

A. SDM fiber technologies

The basic concept of SDM relies on placing in a given fiber structure or fiber arrangement, numerous spatial channels. The channels' type vary depending in which factor of SDM we are exploiting; diversified cores, multiplexed LP modes or modes carrying OAM, multiple cores each supporting few multiplexed LP modes.

Single-Mode Fiber bundle – fiber ribbon

Early attempts to realize SDM were by means of SFM ribbon i.e. using by many conventional SMFs (ranging from tens to hundreds of SMFs) packed together create a fat fiber bundle or ribbon cable. The overall diameter of these bundles varies from around 10 mm to 27 mm. Fiber bundle delivers up to hundreds of parallel links, at the expense of its big dimension, making it less space efficient. Fiber bundles have been commercially available [10], [11] and adopted in current optical infrastructure for several years already. Fiber ribbons are also commercially used in conjunction with several SDM transceiver technologies

[12]–[14].

Multi-Core Fiber (MCF)

Although MCFs are gaining increasing popularity lately, the idea of having multiple single mode cores placed in a sole fiber structure is not that new. The first MCF was manufactured back in 1979 [7]. However, the demand then was limited and the optical community was reluctant to adopt it. Currently, MCF seems to be one of the most popular and efficient ways to realize SDM [15]. There are two main design options for the placement of the cores, the uncoupled-style and the coupled-style. The second allows high coupling to occur between signals propagating in adjacent cores, exhibiting in this way large amounts of crosstalk interference even after some meters. In that case, the use of MIMO-DSP on the receiver side is inevitable. For this reason the uncoupled-style is mostly preferred for R&D. Many core arrangements have been proposed (Fig. 1); the One-ring [16], [17] and the Dual-ring structure [18], the Linear Array [19], [20], the Two-pitch structure [21] and finally the Hexagonal close-packed structure which is also the most prominent [22]. Examples of this style, with 7 cores [15] and 19 cores [23] have already been demonstrated and used in experiments. Recently, a novel MCF structure was proposed [24], consisting of 19 cores in a circular formation, instead of hexagonal, and different core-pitch values for center and outer cores. That resulted in a slight increase of the cladding diameter; however inter-core crosstalk was significantly reduced to only -42dB in 30km amplified transmission. Diameters of MCFs vary between 150 and 400 μm , depending mostly in core pitch values and formation.

Multi-core fibers can deliver exceptionally high capacity up to Pbits per second, supporting at the same time *spatial superchannels* (i.e. groups of same-wavelength sub-channels transmitted on separate spatial modes but routed together). Additionally they have the ability for switching also in the space dimension, other than time and frequency. For example, 3 cores of a MCF could be switched together at first creating a superchannel and then in the next network node, one data-stream propagating in one of those cores could be dropped or switched to another core etc. In a real network environment, such a strategy could provide sufficient granularity for efficient routing and facilitate

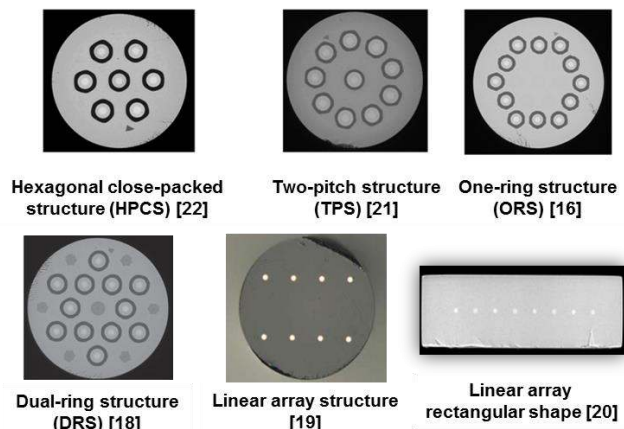

Fig. 1. Different MCF core arrangement designs

ROADM integration, and could help to simplify network design. This is possible since the modes are routed as one entity, foster transceiver integration (e.g. share a single source laser in the transmitter and a single local oscillator in the receiver), and lighten the DSP load by exploiting information about common-mode impairments such as dispersion and phase fluctuations. In addition, MCFs have approximately the same attenuation values as common SMFs, so no extra amplification would be needed when replacing the old infrastructure; needless to say, that this is crucial from a network-design point of view. There are though some cons on using spatial superchannels. It can lead to inefficient resource allocation and 2D (space-spectrum) fragmentation.

The most important constraint in MCFs is the inter-core crosstalk, in other words, the amount of optical signal power “leaking” from adjacent cores to a specific one, causing interference with the signal already propagating there. There are a lot of ongoing studies on how to minimize crosstalk in a MCF structure [25], [26] and have showed that crosstalk can be successfully addressed by using trench-assisted cores (Step-Index), by utilizing the fiber bend and by keeping the fiber cores well-spaced. Other solution proposed is using cores with different refractive indexes, resulting in a heterogeneous MCF [27], or even assigning bi-directional optical signals in adjacent cores to avoid long co-propagation on the same direction thus reducing interference [28]. A more detailed analysis on MCF crosstalk issues is described in the second part of this paper. There we investigate and evaluate various MCFs, in terms of their crosstalk levels, and associate them with distinct network use-cases while addressing their unique requirements.

Multi-Mode Fiber (MMF) - Few-Mode Fiber (FMF)

The fiber concept best known for Mode-Division Multiplexing is Multi-Mode Fiber (MMF). MMFs are optical fibers which support tens of transverse guided modes (LP modes [29] as in Fig. 2) for a given optical frequency and polarization. MMFs operate efficiently in short distances, such as tens of meters. The main obstacles with MMFs, especially when having many modes co-propagating, are the modal dispersion, modal interference and high Differential Mode Group Delay (DMGD), which make long-haul transmission simply impossible. The only way to deal with such issues is to compensate those impairments through

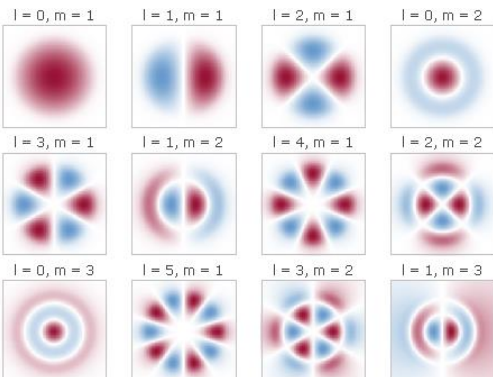

Fig. 2. Some of the fundamental LP modes used in Mode-Division Multiplexing in MMF, FMF and FM-MCF [29].

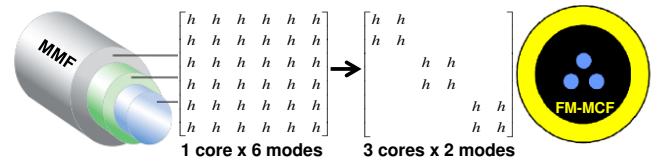

Fig. 3. Digital Signal Processing (DSP) complexity tables for a 6-mode MMF and a 3-core 2-mode FM-MCF. Here h symbolizes complexity. Both solutions are resulting in a SDM factor = 6, yet in the second case the total MIMO calculation complexity is considerably lower.

heavy MIMO-DSP on the receiver side. Recently a 22.8 km transmission of 30 spatial and polarization modes over MMF utilizing 30×30 MIMO was demonstrated [30]. In order to relax the massive MIMO DSP requirements, Few-Mode Fiber (FMF) has been proposed [31], [32]. FMFs are in principle same as MMFs, but are manufactured to allow propagation of less LP modes, thus lightening DSP load in the receiver end and making long-distance communication achievable [33], [34]. Of course, from a network point of view [35], proper transceivers, amplifiers and mux/demux would also be needed to complete the puzzle. All in all, supposing in the future there will be faster and better multimode receivers to relax MIMO-DSP, MMF and FMF could then multiplex even more LP modes, being more efficient in a SDM network.

Few-Mode Multi-Core Fiber (FM-MCF)

The combination of a multi-core fiber and a few-mode fiber, known as Few-Mode Multi-core Fiber (FM-MCF) is a very attractive SDM approach [36]–[39]. Indeed it incorporates benefits from both MCFs and MMFs without adopting all of their drawbacks. FM-MCF has increased capacity by a factor of = (#cores) * (#modes), and when combined with Dense WDM, transmission capacity can even reach 255Tbps [40]. Remarkable advances realized lately on the area are: a heterogeneous 3-mode ($LP_{01, 11, 21}$) 36-core fiber that supports 108 spatial modes [41] and a 6-mode ($LP_{01, 11a, 11b, 21a, 21b, 02}$) 19-core fiber that supports 114 spatial modes [42]. According to [43] more than 300 of FM-MCF channels can theoretically be supported. However, the prime advantage of FM-MCF compared to MMF/FMF is the significantly lighter MIMO DSP required in the receiver side. As shown in Fig. 3, a MMF carrying 6 LP modes requires quite heavy DSP for its MIMO matrix, when in the case of having 3 cores each carrying only 2 modes, the matrix is much simpler and the DSP needed less. As in MCFs, FM-MCFs’ most critical aspect, is inter-core crosstalk between the fundamental LP_{01} mode and higher order modes, such as LP_{11} , LP_{21} etc. In a nutshell, FM-MCF is a very promising fiber technology for future SDM networks to deliver high capacity and scalability, provided that efficient TxRx, mux/demux and amplifiers would be available in the next years.

Vortex Fiber carrying Orbital Angular Momentum (OAM)

An upcoming technology that could contribute in the new era of SDM is the so called Vortex Fiber for OAM multiplexing [9], [44]–[48]. Optical vortices are light beams

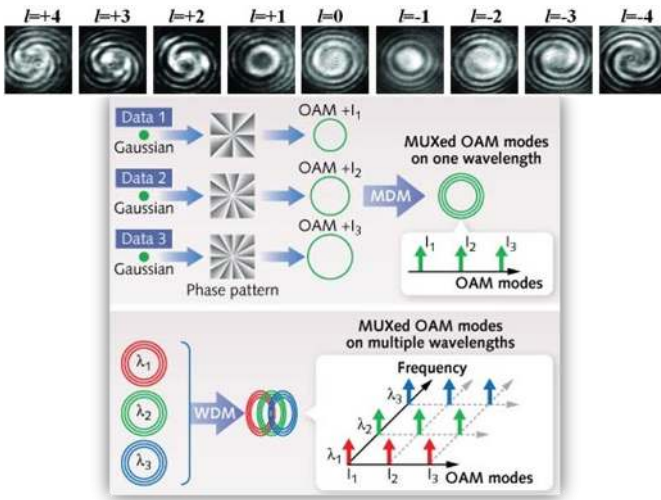

Fig. 4. Multiplexing of OAM modes (SDM) in single wavelengths and then multiplexing in frequency domain (WDM) [44],[45].

made of photons that carry orbital angular momentum (OAM). In quantum theory, individual photons may have the following values of OAM:

$$Lz = l h \quad (1)$$

In Eq. (1), l is the topological charge and h is Planck’s constant. The theoretical unlimited values of l ($\pm 16, \pm 14, \pm 12, \pm 10, \pm 8, \pm 4 \dots$), in principle, provide an infinite range of possibly achievable and multiplex-able OAM states (see Fig. 4). These OAM modes can be multiplexed in single wavelengths and then be multiplexed in the frequency domain (WDM) as well [49]. Vortex fibers for OAM multiplexing are one of the most promising SDM solutions for the future networks as it can potentially scale with reduced crosstalk compared to FMF between discrete modes.

Hollow-Core Photonic Band Gap Fiber (HC-PBGF)

Instead of a solid core, HCFs are hollow from inside, as seen in Fig. 5, containing air and wave-guiding is achieved via a photonic bandgap mechanism. Initially, HCFs were not intended to be used for SDM, but as a substitute for SMFs [50]. The fact that nearly 90% of the light propagates through air, offers ultra-low latency (almost 30% reduction from SMF) and enormous decrease in non-linear effects, potential for extra-low loss, while at the same time supports several LP modes [51], the number of which depends on the fibers dimensions and design [52]–[57]. Finally, HCFs are theoretically found to have less loss around the $2\mu\text{m}$ area [58], opening a new frequency band for transmission. All in

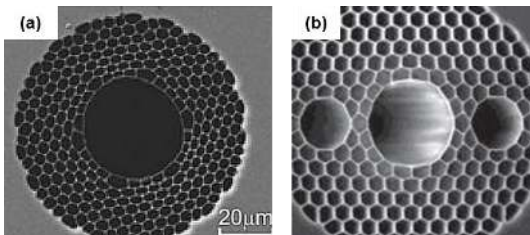

Fig. 5. (a) Cross-section of a single-core 37-cell HC-PBGF able to carry three LP modes [53] (b) Cross-section of a Tri-core HCF for low latency single-mode transmission [55]

all, HCF seems to be the perfect candidate to combine SDM Mode-Multiplexing [53], [56] and low latency for future high-capacity latency-sensitive networks [59], i.e. High-Performance Computing (HPC) networks and high frequency trading applications.

Multi-Element Fiber (MEF)

Another alternative to uncoupled SDM fibers is with the Multi-Element Fiber, which consists of multiple fiber elements drawn and coated close together in a single coating [60]–[63]. Three, five and seven elements have been introduced in a single fiber structure, as shown in Fig. 6. There is zero crosstalk between those spatial channels. However, the greatest advantage of MEF over the MCF and MMF, is that those fiber elements can easily be separated from the main structure and be coupled, using conventional SMF connectors, to any device of the existing infrastructure, avoiding the use of SDM mux/demux. In this way the overall cost and power budget of the network is kept low. The drawback of existing MEF compared to MCF or MMF, is that it delivers less spatial channels for the same diameter/cross-sectional area.

B. SDM Amplifiers

Amplification is a crucial aspect of a network, especially for long distance links i.e. metro, core and long-haul networks, therefore integrated SDM amplifiers [64] are an absolute necessity towards spatial multiplexed future networks. Several SDM amplifier solutions have been proposed. These include pumped-distributed Raman amplifiers for few-modes [65] and long-haul multi-core transmission [66], fiber bundle Erbium Doped Fiber Amplifier (EDFA) with low crosstalk and uniform gain characteristics [67], multi-element EDFA for core or cladding pumping [39], 7- and 19-core EDFAs for core or cladding pumping again with a gain over 25dB [24], [68], [69] and Multi and Few-Mode EDFAs for a range of modal groups and more than 20dB gain [70]–[73]. Core-pumping involves the coupling of, as many as the number of cores of a MCF, laser sources, usually in the frequency region of 980/1310nm, throughout the length of the erbium doped fiber. The original signal after co-propagating with the pumps in each core inside the erbium doped region gets amplified, just as in classical EDFA systems. In cladding-pumping, a single light source pumps all the cores/modes simultaneously coupled in the erbium doped cladding, instead of being separately coupled in each core. Based on the above, it can be argued that SDM amplifiers (especially those utilizing cladding pump) are more energy efficient in

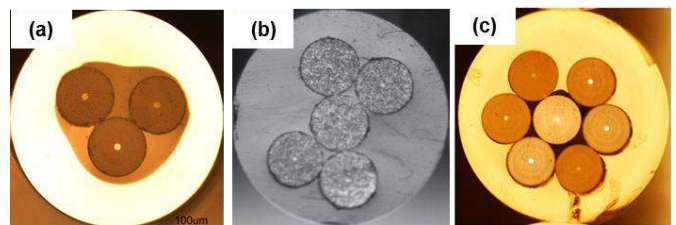

Fig. 6. As presented in [61]. (a) Cross-section of a 3-element MEF (b) Cross-section of a 5-element MEF (c) Cross-section of a 7-element Er-doped MEF used for core-pumped amplification

the boost amplification stage than deploying parallel conventional EDFAs for amplification of the SDM channels of a link after de-multiplexing them [74]. Nevertheless, the main deficiencies of those SDM amplification technologies are, a) the insufficient gain flattening, in order to equalize spatial channels' power level, b) the fact that most of them do not scale for more than 10 channels, and c) the lack of the combination of Few-Mode and Multi-Core EDFA technologies for FM-MCF-based SDM networking.

C. SDM Multiplexers/De-Multiplexers

Coupling of MCF, FMF and FM-MCF to ordinary single-core fiber (also known as FAN-IN/FAN-OUT), and vice versa, is a challenging technological issue that impacts the viability and performance of SDM concepts.

Firstly, the MCF coupling schemes that have been reported (and some commercialized) can roughly be categorized in indirect coupling and direct coupling methods (Fig. 7). Indirect coupling is essentially a free space optics scheme that relies on lens system [75]–[77]. Although it can scale for high number of MCF cores and has suppressed crosstalk, it is usually bulky and requires sophisticated optomechanics. This technology is commercialized by Optoquest [78]. Direct coupling methods implement waveguide-optics interface that directly connects the MCF with the SMFs. Tapered Multi-Core Connector (TMC) or simply tapered cladding is the first direct coupling approach [66], [79]–[81]. A bundle of fibers with tapered cladding is spliced to the MCF. Inside the taper, the spacing of the cores is reduced from the one in the single mode fiber bundle to the one in the multicore fiber. This technology is susceptible to crosstalk, needs advanced splicing techniques, but is quite compact and also commercialized by US company Chiral Photonics [82]. Waveguide coupling is another direct coupling solution proposed for SDM mux/demux. MCF to SMF connection is realized by inscribing spatially isolated waveguides that connect each core of the MCF to a particular SMF [83]–[85]. Waveguide coupling has the advantage of being a very compact, low-

complexity and flexible, in terms of adapting to various MCF designs, approach. This technology has been commercialized by Optoscribe [86].

For coupling SMF to Few-Mode Fibers or Few-Mode Multi-core Fibers for MDM, another type of spatial mux/demux is needed to set the LP modes co-propagate in the same fiber structure and in the receiver to extract those discrete modes [87]. Free space approaches, using phase plates, mirrors, beam splitters and special lenses for alignment have been originally proposed [34], [88]. They offer good mode selectivity but suffer from large insertion losses. Other options for mode multiplexing based on photonic lantern and waveguide coupling have been also demonstrated [89]–[91] for 6 and 12 spatial and polarization modes. In either case, losses were found to be less than 6dB, showing the potential to decrease even more in the future. In addition, progress has been made in integrating mode-multiplexers, like in [92], with the aid of silicon photonics technology. Photonic integrated grating couplers are also used for SDM mux/demux and are reviewed further in section E.

Finally, coupling of MCF to MCF and MMF to MMF is certainly a simpler task than FAN-IN/FAN-OUT, however it involves a fair deal of complexity [93]. Both Butt-joint type MCF connectors [94] as well as lens coupling type MCF [93] have been demonstrated.

D. SDM Transmitters (Tx), Receivers (Rx) and Transceivers (TxRx)

SDM transmitters (Tx), receivers (Rx) and even integrated together, transceivers (TxRx) have been demonstrated (Fig. 8). SDM TxRx reduce the overall losses of the network by utilizing space more efficiently, as they relax the requirement for SDM multiplexers, demultiplexers in the transmitter and receiver side respectively. As mentioned before it is crucial for all network components, especially TxRxs, to adequately take advantage of the space provided.

A few SDM Tx (or Rx) modules (Minipod™, Micropod™), that have been developed and commercialized by Avago company [12], employ 12-fiber ribbon cable to demonstrate 12 SDM channels, using Vertical-Cavity Surface-Emitting Lasers (VCSEL) for transmission in 10Gbps data rate each, resulting in 120Gbps total bandwidth per module. Other similar products, LightABLE™ from ReflexPhotonics [14] and FireFly™ from Samtec [13] are also available. All the above deliver proper capacity and they can be installed, connected and handled quite easily. Relevant to the above is the development of Active Optical Cables (AOC) where the Tx and Rx are integrated in the fiber module. Fujitsu has recently exhibited a 100Gbps Multi-Mode AOC that can deliver 100 Gbps data rates over four lanes of 25 Gbps over a maximum range of 100m [95].

A 7-core Distributed Feedback (DFB) laser [96] has been presented, with linewidth below 300kHz for all cores, starting a new trend for multi-core lasers capable of transmitting directly in a MCF. Similarly, but on the receiver side, a 7-core polarization-independent receiver has been manufactured with silicon photonics and tested for

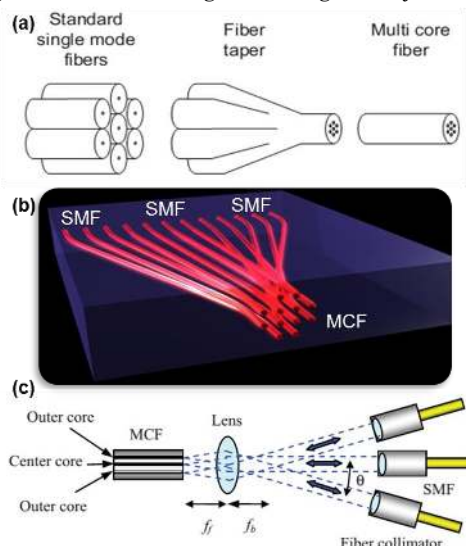

Fig. 7. Direct and indirect spatial mux/demux schemes for MCFs (a) Tapered cladding [80] (b) Waveguide coupling [86] (c) Lens system [76]

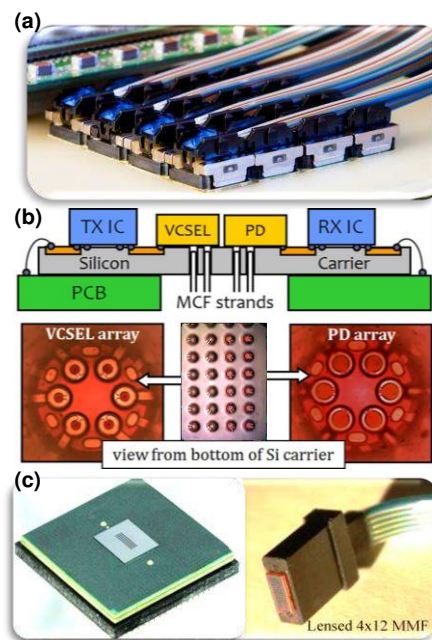

Fig. 8. Various SDM transceiver technologies (a)Avago Minipod™ utilizing 12-SMF-ribbon [12] (b)Integrated photonic TxRx chip for directly coupling to MCF fiber [94,95] (c)4x12 VCSEL/PD array opto-chip interfacing a MMF-bundle supporting 480Gbps Tx and Rx [96]

simple on-off keying reception [97]. These early results hold much promise for future fully-SDM reception schemes. Taking it a step further, a completely photonic integrated transceiver (TxRx) chip has been demonstrated with 24 channels reaching 300Gbps bidirectional capacity, using arrays of low-power consumption VCSELs and high-speed photodiodes [98]. Based on that research, further progress has been made, leading to an integrated transceiver chip which has both VCSELs Tx and Photodiodes (PD) Rx interface in order to be directly butt-coupled to a Multi-Core Multi-Mode fiber [99], [100]. Using the 6 outer cores of the fiber as spatial channels, up to 20Gbps was supported per channel and the whole link demonstrated 120Gbps total bandwidth. Keeping up with the pace of the above successful approaches, an even more capable transceiver chip has been introduced [101]. It is based on 24 VCSELs and 24 PDs in array arrangement in order to interface with a 4x12 MMF array bundle. 480Gbps total transmission and another 480Gbps reception have been demonstrated within a very confined chip-area (5.2mm x 5.8mm) offering an excellent example of space utilization. More discussions on SDM TxRx, regarding space and capacity, is following in the second part of this paper.

TxRx technologies like all the above, along with SDM amplifiers, cross-connects and ROADMs are expected to support the future pure SDM network concept, utilizing the space domain from the source up to the destination, throughout the whole network.

E. The role of Photonic Integrated Circuits (PIC) and Silicon Photonics

In order to meet Datacom requirements the functionalities commonly performed by discrete devices are

migrating to Photonic Integrated Circuits (PIC). Although research interest in PIC was always vivid, recent advances in data centers, the natural space of SDM, has placed them in the forefront of photonics research. SDM implementation benefits from these and as such it is instructive to deal with these in some detail. By no means the present short review presented in this section is complete nor is the authors' intention. Instead only PIC research aspects relevant to SDM are discussed. For a full review the interested reader is referred to e.g. [102]–[104].

PICs have been demonstrated using monolithic integration [102], [103] and hybrid integration [104]. Monolithic photonic integration exploits mature wafer scale planar circuits processing techniques thus lowering cost. Through hybrid integration it is possible to take advantage from the best performing III-V materials and CMOS technology. Here, silicon based material platform e.g. Silicon On Insulator (SOI) is integrated with III-V materials using wafer bonding techniques [105].

The interface between SDM and the PIC technology is the multiplexing/de-multiplexing of PICs' outputs/inputs to/from MCF and/or FMFs. There are a number of nonintegrated coupling technologies, some of which already reviewed in the present contribution. These include long period gratings for mode conversion [106], phase plates [107] spatial light modulators [108] and free space optics [75], glass inscribed waveguides [86] and cladding spliced bundle of fibers [82]. While these solutions can deliver, they are bulky and do not favor wider scale deployment. The alternative solution is the development of multiplexers/de-multiplexers that are integrated on PICs described in previous section C. These are based on grating couplers [92], [109], [110]. Despite the fact that grating couplers have higher losses than non-integrated solutions and facet couplers, they can be integrated and can be used as polarization splitters and rotators and also allow mode size manipulation. Another integrated PIC approach involved the direct interfacing of VCSEL arrays arranged in a hexagonal pattern to match MCF profile [100].

An example of PICs' potential for SDM specific functionalities is the recent demonstration of an all-optical MIMO de-multiplexer [111]. For SDM in FMF, power hungry electronic MIMO DSP is required. The solution is provided by PICs that realize all optical MIMO thus saving in power consumption, cost and size.

III. QUANTITATIVE ANALYSIS AND EVALUATION OF SDM TECHNOLOGIES

So far, SDM theoretical and experimental research was based on total bandwidth, capacity and aggregate spectral efficiency, without considering the space domain at all. It is essential to have a reference point in order to analyze and evaluate SDM technologies. To this end, appropriate Figures of Merit along with their metrics to quantify SDM features are necessary. Two such new metrics are proposed in this paper. The first one aims to measure Spectral Efficiency (SE) per cross-sectional area of the fibers (Spectral-Spatial Efficiency – S.S.E.) and the second focuses in evaluating components used for optical networks with regards to their footprint area and/or volume (Components Performance per Footprint Area / Volume – CPFA/CPV). The figures of merit (FoM) introduced in this paper are

numerical expressions based on spatial effectiveness, representing measures of efficiency and performance for SDM fiber technologies and devices. Our proposed metrics lead to effective comparison and categorization of SDM approaches. That offers a two-fold benefit; the evaluation of current and upcoming technologies as well as the connection of network systems with technology, considering capacity, S.E. and space.

The rest of this section is organized as follows: first we introduce the SDM FoM and we use them to assess the available technologies. Then we present briefly the requirements of metro/core networks and Data-center Networks (DCN), and how SDM could address those in terms of fibers and network devices. Furthermore, we focus in the MCF's greatest impairment, i.e. inter-core crosstalk, and we study the limitations that this imposes to an SDM network.

A. Spectral-Spatial Efficiency (SSE)

In order to identify *SSE* as a metric we propose a simple formula (Eq. 2), expressing the aggregate SE of the whole fiber divided by the area of its cross-section.

$$SSE = \frac{SE \cdot SM}{A_{cross}} \quad (2)$$

In Eq.2, *SE* is the Spectral Efficiency (b/s/Hz) of each spatial mode, *SM* the number of discrete Spatial Modes, and A_{cross} (mm^2) the area of the cross-section of the fiber. *SM* could be the number of cores in a MCF, the number of LP modes (single or dual polarization) in a FMF, the amount of elements in a Multi-Element Fiber, the number of multiplexed modes carrying Orbital Angular Momentum in a Vortex Fiber or the number of cores multiplied by the number of LP modes in a FM-MCF. Using the above mathematical formula, we calculated the Spectral-Spatial

Efficiency for 10 fiber structures used in SDM in various ways. These fibers were reviewed qualitatively in the first part of this paper, and here we evaluate them quantitatively. Fig. 9 illustrates the SSE of these SDM fiber technologies for three discrete SE values, 1, 4 and 8 b/s/Hz. This figure shows that fibers with more spatial channels and less cross-section area, use spectrum much more space-efficiently. Remarkable distinction is found between the SMF ribbon and the FM-MCF (5 and 5928 b/s/Hz/ mm^2), as shown in Fig. 9. This is due to the large difference between the A_{cross} of the two technologies, although SMF-bundle outnumbers FM-MCF in Spatial Modes (Table I).

The fibers' detailed specifications, cladding diameter, number of spatial modes along with their SSE values for 8 b/s/Hz SE can be found in Table I. In the cases of the fiber-bundle and MEF, coating diameters have been used, since the fibers and the elements respectively do not share the same cladding, so taking their cladding diameter as a reference would be inaccurate. In the same table, the last two entries represent theoretical fiber designs extrapolated from existing MCF and FM-MCF designs (core pitch, cladding diameter, etc.) and also from the centered hexagonal number (see Appendix), in alignment with the mostly-used hexagonal core-arrangement scheme. Offering 169 and 222 spatial modes, these designs show excellent SSE in comparison with the real implementations, 5,694 and 18,469 b/s/Hz/ mm^2 respectively. Although this is an encouraging fact for the future SDM fibers, one needs to consider the practical challenges on drawing large cladding diameter, i.e. 550 μm , MCFs.

The outcome of the above evaluation using SSE, shows that there is enough room for future improvement in SDM networks. Especially in reducing cable complexity and conventional fiber mesh by having fewer SDM fibers still offering the same and higher spectral efficiency and capacity services. Nevertheless, an important subject that

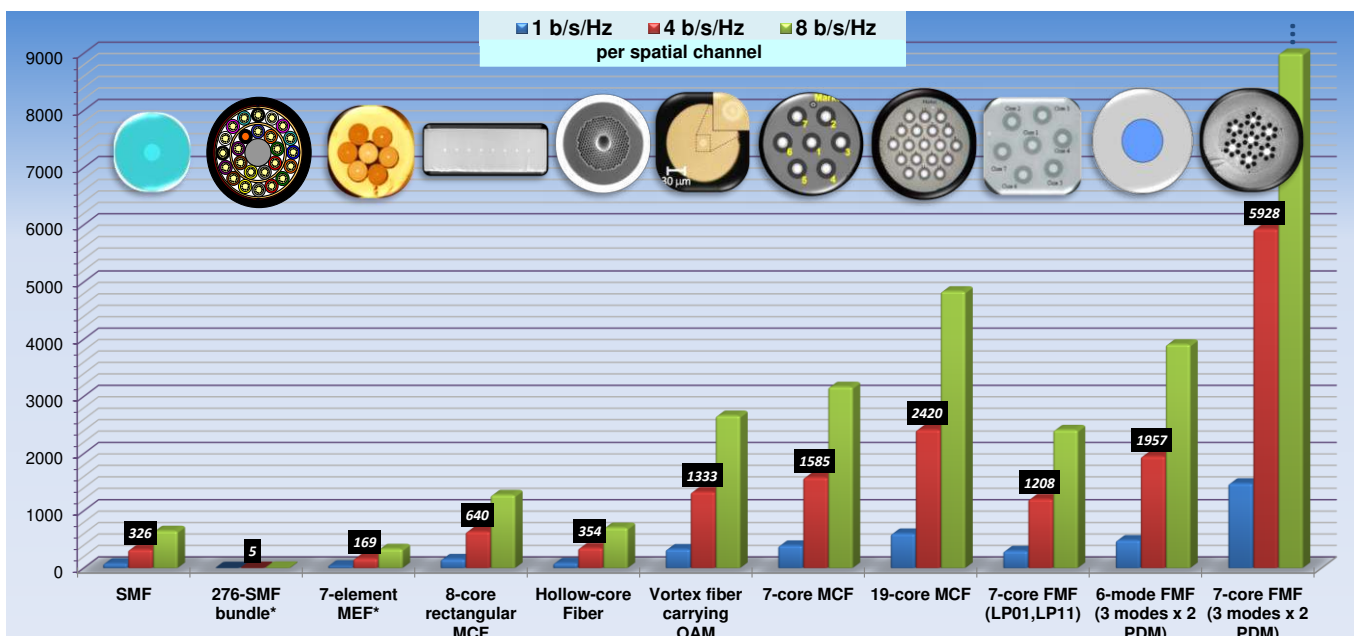

Fig. 9. Spectral-Spatial Efficiency (b/s/Hz / mm^2) evaluation of various SDM fibres. The columns on each fibre represent 1, 4, 8 b/s/Hz Spectral Efficiency per spatial channel respectively. Indication labels (middle column) show the value of SSE for 4 b/s/Hz SE.

TABLE I
STUDIED FIBER TYPES UTILIZING SDM WITH THEIR SPECIFICATIONS AND
THEIR VALUE OF SPECTRAL-SPATIAL EFFICIENCY FOR S.E. PER SPATIAL MODE = 8 B/S/Hz

<i>Fiber Type</i>	<i>Cladding Diameter (mm)</i>	<i>A_{cross} (mm²)</i>	<i>Spatial Modes number</i>	<i>SSE (b/s/Hz/mm²)</i>	<i>Reference</i>
SMF	0.125	0.012	1	652	-
276-SMF bundle	~17*	226.865	276	10	[10],[11]
7-element MEF	~0.460*	0.166	7	337	[62]
8-core rectangular MCF	0.400 x 0.125	0.050	8	1280	[20]
Hollow-Core Fiber	0.120	0.011	1	708	[51]
Vortex Fiber carrying OAM	0.125	0.012	4	2667	[47]
7-core MCF	0.150	0.018	7	3171	[15]
19-core MCF	0.200	0.031	19	4841	[24]
7-core FMF (LP ₀₁ ,LP ₁₁)	0.243	0.046	14	2416	[38]
6-mode FMF (LP ₀₁ ,LP _{11a} ,LP _{11b} x 2 PDM)	0.125	0.012	6	3913	[33]
7-core FMF (LP ₀₁ ,LP _{11a} ,LP _{11b} x 2 PDM)	0.190	0.028	42	11,857	[37]
169-core MCF	0.550**	0.237	169	5,694	-
37-core FMF (LP ₀₁ ,LP _{11a} ,LP _{11b} x 2 PDM)	0.350**	0.096	222	18,469	-

* coating diameters instead of cladding are presented

**extrapolated from Centered hexagonal number and existing core pitches

has to be addressed is the relation and possible trade-offs between the SSE, crosstalk and link reachability when different SDM networking approaches are used. A potential way to investigate this is by associating OSNR and the various modulation formats with SSE and reachability of signals propagating in SDM systems as well as considering any crosstalk constraints.

B. Network Components Performance per Footprint Area (CPFA) and Components Performance per Volume (CPV)

The second FoM introduced here is about measuring how efficiently network components perform in the space they occupy. The metric for this FoM varies and depends on what aspect of performance we evaluate each time. It is calculated by dividing the value of the device performance by the area of the unit's footprint or volume. By the term device performance we refer to capacity (Gb/s) for the case of transceivers, number of concurrently spatial modes amplified for the case of SDM amplifiers, energy consumption (Joule), amount of switch ports for the case of an optical switch or number of spatial channels a mux/demux is able to (de)multiplex etc. To measure space, we either use the footprint area (in mm²) each technology has, or the volume (in mm³) of each network element.

For example, transceivers can be quantitatively evaluated by measuring their performance in terms of capacity divided by their footprint area. In Table II, several TxRx technologies are compared using the proposed FoM. In order to have the same reference, we calculate only the transmission capacity for all the technologies, even though some of them integrate both Tx and Rx in the same footprint area. The IBM integrated approach utilizes space in the best possible way, offering 48 channels (24 Tx and 24

Rx) of 20Gb/s each in only just 30 mm², which results in 16 Gb/s/mm² Tx performance per footprint area, way higher than the commercial solutions. Towards future networks where even 1Tbps ultra-high bandwidth links might be required and also considering the advances on VCSELs [112], [113] and integration technology, we came up with a couple of theoretical designs of TxRx. Theoretical designs, similar to IBM's integrated one, implement 24 channels, but with 56Gbps VCSELs instead of 20Gbps, resulting in a total capacity of 1.3Tbps and a CPFA of 44.8 Gb/s/mm² (theoretical Design A). In Design B we assume a reduction

TABLE II
TRANSCIVER CAPACITY PER FOOTPRINT AREA (Gb/s/MM²)
FOR DIFFERENT SDM IMPLEMENTATIONS

<i>SDM TxRx technology</i>	<i>Total capacity</i>	<i>A_{foot} (mm²)</i>	<i>Capacity/A_{foot} (Gb/s/mm²)</i>
<i>Minipod</i> TM [12]	<i>12ch*10G= 120Gbps</i>	<i>(Tx or Rx) ~409</i>	0.29
<i>Micropod</i> TM [12]	<i>12ch*10G= 120Gbps</i>	<i>(Tx or Rx) ~64</i>	1.87
<i>LightABLE</i> TM [14]	<i>12ch*10G= 120Gbps</i>	<i>(Tx or Rx) ~320</i>	0.37
<i>FireFly</i> TM [13]	<i>12ch*14G= 168Gbps</i>	<i>(Tx or Rx) ~451</i>	0.37
<i>Integrated approach</i> [97]	<i>24ch*20G= 480Gbps</i>	<i>(Tx and Rx) ~30</i>	16
<i>Theoretical design A</i>	<i>24ch*56G= 1.3Tbps</i>	<i>(Tx and Rx) ~30</i>	44.8
<i>Theoretical design B</i>	<i>24ch*56G= 1.3Tbps</i>	<i>(Tx and Rx) ~22</i>	61

TABLE III
NUMBER OF MUX/DEMUX SPATIAL CHANNELS PER
FOOTPRINT AREA AND PER VOLUME

<i>SDM mux/demux technology</i>	<i>(De)Mux channels</i>	A_{foot} (mm^2)	<i>Volume</i> (mm^3)	$\#Channels/A_{foot}$ ($/mm^2$)	$\#Channels/Volume$ ($/mm^3$)
<i>Optoscribe 3D Optofan [86]</i>	<i>7,19 (or more)</i>	<i>750</i>	<i>7500</i>	<i>0.025</i>	<i>0.0025</i>
<i>Chiral Photonics Fan-In-Out [82]</i>	<i>7</i>	<i>900</i>	<i>5400</i>	<i>0.007</i>	<i>0.0010</i>
<i>Free space optics [75]-[77]^a</i>	<i>7,19</i>	<i>>>cm²</i>	<i>>> cm³</i>	<i><< than others</i>	<i><< than others</i>

^a extremely bulky devices

in the footprint area as well, thus the CPFA climbs to 61 Gb/s/mm². In future SDM Datacenter Networks, such technologies could superbly fit the rest of the infrastructure, since not only they utilize space ideally, but also they can be coupled directly or via mux/demux to SDM fibers, collaboratively offering large number of parallel spatial channels with low loss. Not to mention that the VCSELs that are used are regularly cost effective and energy efficient, both crucial factors for DCN designs.

In order to evaluate spatial multiplexers / demultiplexers, CPFA and CPV can be used once again. To do so, as seen in Table III, we consider how many, for example cores of a MCF, can each technology de/multiplex at the same time and what is each technology's footprint and volume. The best performance is shown by the waveguide coupling technique that Optoscribe is providing, since it can mux/demux 19 (or even more) MCF channels at a compact device of 7500mm³ volume. This will prove really crucial when SDM mux/demux will be needed to multiplex/demultiplex multiple inputs/outputs of servers in a Datacenter rack, where the space is extremely limited and should be used as efficiently as possible. However, in such a Datacenter scenario, integrated TxRx directly-coupled to SDM fibers would apply even better, saving even more space, energy and cost.

IV. NETWORKING ASPECTS OF SDM: HOW CAN IT SERVE DIFFERENT NETWORKS

It is becoming evident that, to fully exploit SDM networking, it is necessary to develop novel approaches in network functionalities enabled by the additional spatial dimension while addressing additional constraints, i.e. spatial crosstalk, mode-coupling. SDM provides the necessary building blocks and technologies to set up scalable multi-dimensional network devices and subsystems, like ROADMs, in order to equip future metro/core nodes, which will offer flexibility in switching in multiple dimensions (SDM-WDM-TDM). Although there is still an open debate of whether SDM technologies are suitable for metro/core and backbone networks, it seems to be a lot more interest in adopting SDM inside Data Center Networks (DCN) both by the research community and by the industry. The challenges and potential difficulties of accepting SDM solutions in future networks are discussed in this section. Other than that, innovative techniques for transmission using Self-Homodyne Coherent Detection, and for routing & resource allocation have been also developed and presented. Later in this section, we study MCF's main

constraint, inter-core crosstalk. The outcomes of this study then feed an analysis on new designs for MCFs closely depending on the different network links and use-cases. Finally, there is a discussion on metro/core and datacenter requirements and by linking the appropriate technologies we show how SDM can fulfill those requirements.

A. SDM Reconfigurable Optical Add/Drop Multiplexers (ROADMs)

In order for SDM to be applied successfully in a new photonic mesh network concept, except from transmission/reception and amplification, other functions should also be supported, such as flexible switching and adding/dropping channels in optical nodes. Taking that into account, researchers have been focusing into Reconfigurable Optical Add/Drop Multiplexer nodes, which offer elastic switching in space, apart from the frequency domain. Indeed spatial super-channels, i.e. groups of high capacity subchannels carried by the same wavelength, but in different cores or modes of an SDM fiber, through an SDM ROADM, have been already achieved [114], [115].

There are different ways to achieve spectrally and spatially elastic optical networks (EON) and ROADMs; ranging from less flexible WDM-only fixed-grid options to SDM-WDM flex-grid alternatives with flexible spatial mode allocation [116]–[118]. The simplest way for wavelength granularity switching is by allocating and switching fixed spatial super-channels of the same wavelength along the cores/modes of an SDM fiber. This can be easily realized by routing all cores/modes for express, add and drop functions in a per wavelength basis with Wavelength Selective Switches (WSS) like in Fig. 10. In order to add more degrees of freedom for flexibility, instead of having fixed spatial superchannels, various spectrum combinations could be allocated in the different cores/modes. However, such an option would increase the design complexity of the switching node with the need of several Wavelength/Spectrum Selective Switches (WSS/SSS) and large port-count optical cross-connects (OXC). Another possible option that would offer space-wavelength switching to fibers with coupled mode arrangements like Few-Mode Multi-core Fibers, is the switching of independent groups of modes together (Fig. 11). For instance dropping one core of a FM-MCF in a node would result in dropping all the spatial modes that core contained. In that way, two levels of spatial flexibility and granularity could be realized instead of one.

Architecture on Demand (AoD) ROADMs can support

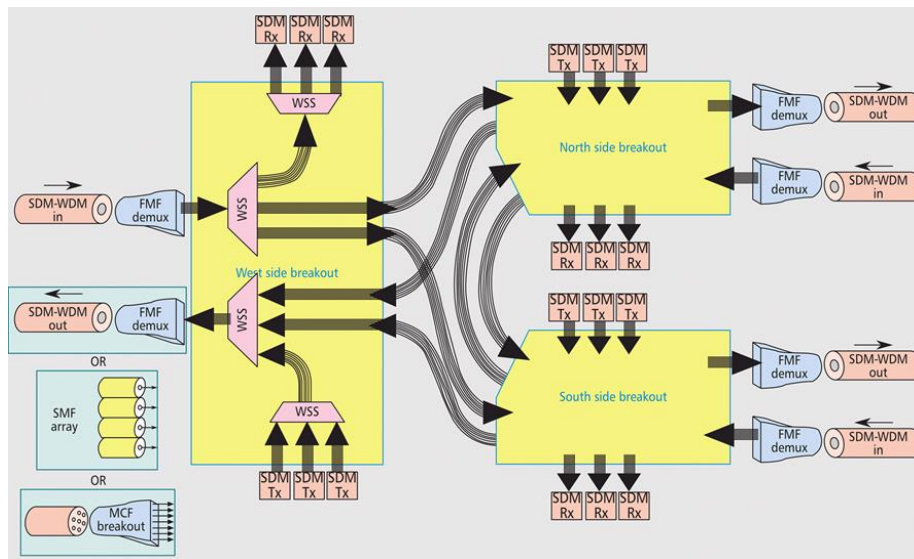

Fig. 10. Wavelength granularity switching design for SDM ROADMs. All modes are routed in a per wavelength basis [117]

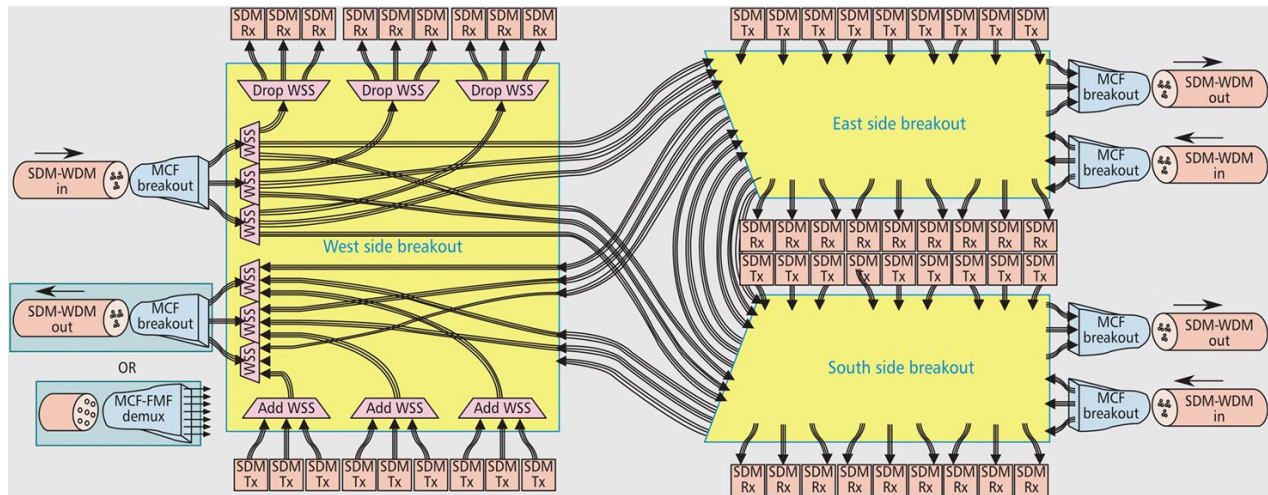

Fig. 11. Group (i.e. Few-Mode Multi-core) switching design for SDM ROADMs. All modes are routed in a per wavelength basis [117]

wide and flexible spatial (i.e. core) as well as spectral switching, as seen in Fig. 12 [119]. This work also proves that by adopting this kind of “white-box” ROADM approach, significant savings could be obtained in terms of switching modules and total energy consumption while scaling to large number of nodal degree and cores per degree.

A first AoD-based implementation has been presented in [114], that supports functions like add and drop of whole spatial superchannels or parts of them, using Bandwidth-Variable Wavelength Selective Switches – BW-WSS (also known as SSS) to do the switching, and 19-core, 7-core MCF to interconnect the nodes. This SDM ROADM architecture demonstrated the degree of flexibility that can be achieved by switching in space and flex-grid frequency domain, dropping slices of the spectrum, thinner or wider, and at the same time adding wavelengths, modulated with advance modulation formats like QPSK and 16-QAM.

Another approach towards SDM ROADMs which supports spatial super-channel routing and switching has been proposed in [115]. As shown in Fig. 13, two 1x20 WSS cascaded with steering mirrors are used for the add/drop/express switching in each core and/or wavelength

(spatial sub-channel) of the whole 7-core MCF (spatial super-channel). The above ROADMs, along with [120], can deliver different capacity to discrete nodes depending on the demand, using WDM and SDM in a very flexible manner. However, proposed ROADMs, using i.e. WSS switches, might face a scalability issue in the future due to the port number limitation of the WSS. A 1x11 Few-mode WSS has been proposed, supporting the switch of spatial superchannels (three spatial LP modes) [121], thus opening the way for future SDM ROADMs able to fully utilize spatial, spectral and time domain. One thing that is still to be developed technology-wise is SDM-enabled switches that can support switching of all the spatial channels of a single MCF/MMF at once from a single port, without the need of de/multiplexing before and after the switch.

Most of the above SDM ROADM designs proposed for various levels of switching granularity (space, wavelength, space and wavelength) can be realized usually by large port-count OXC switches and/or cascaded WSSs, with the exception of the AoD, where studies [122] have shown that an optimized AoD-based ROADM design can lead to up to 40% device and port-count reduction and as a result power-

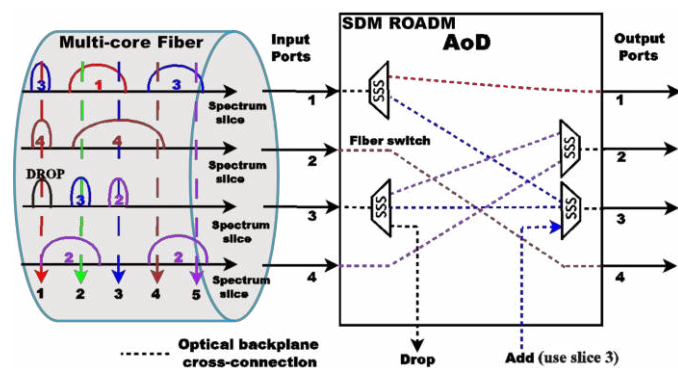

Fig. 12. SDM AoD programmable ROADMs. Inputs from different cores of a MCF, each carrying various spectral configurations, are flexibly switched in space & frequency domain [119].

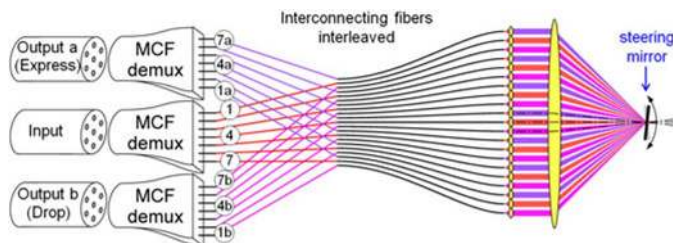

Fig. 13. Operating principle of $7 \times (1 \times 2)$ WSS-based SDM ROADMs using 7-core MCFs. Two cascaded 1×20 WSS were used to realize the express, add and drop functions [115]

consumption savings as well. Although some of those approaches can provide finer granularity by even having the capability to provision and route independent spatial modes or spectrum slices, the complexity and scalability challenges are noticeable. WSS/SSSs might need to scale in extensive numbers depending on the required flexibility degree, and wavelength contention is usually an issue in such multi-dimensional systems. Despite the fact that footprint is currently not as a decisive factor when developing ROADMs as it is in DCNs, SDM integration could accelerate the progress of more space efficient ROADMs (higher CPFA), depending of course on the design and nature of the switching and SDM (de)multiplexing elements.

B. Other SDM networking aspects

Apart from the spatial multiplexed network devices and necessary components reviewed above, there are some more features of SDM that are of equal importance. This includes Multiple Input – Multiple Output (MIMO) Digital Signal Processing (DSP) and self-homodyne coherent detection, both used on the receiver side of a link, as well as routing and allocation of the spatial resources of the network.

Multiple Input – Multiple Output (MIMO) Digital Signal Processing (DSP) and Self-Homodyne Coherent Detection (SHCD)

Usually in MMF/FMF-based and Mode Division Multiplexed networks and especially in longer links, high-coupling between spatial modes takes places. In order to receive the signal properly in the receiver end, it is an absolute necessity to use MIMO processing, which compensates linear impairments like dispersion, crosstalk,

and DGD between modes and polarizations [30], [33], [111]. MIMO systems are usually implemented with multiple equalizers followed by the DSP to clarify the signal and decide about the received symbols. Depending on the received OSNR, heavier or lighter MIMO processing might be needed. That is a tradeoff that should be investigated carefully in real network environments.

SH coherent detection has been proposed [123] in the loosely coupled regime of MCFs, to successfully cancel phase noise on the receiver end, relax the DSP complexity and also enable the use of high-order modulation formats. In the first attempt, the Pilot Tone (PT) was sent on an orthogonal polarization to the actual signal, wasting 50% SE compared to Polarization Multiplexed (PDM) systems. Recent advances on SDM, especially in MCFs, have enabled the use of SHCD, but instead of sending the PT through a PDM channel, this time it is sent through an SDM channel, for example a core of a MCF [114], [120]. Using this technique, precious link resources are saved and therefore can be utilized to increase the SE of the network. In SDM, different channels experience approximately the same impairments, so the PT will most of the times follow the disturbances of the rest data channels, e.g. phase mismatches etc., acting as a local oscillator on the receiver end. Thus, phase-sensitive signals, like QPSK and QAM, can be received with higher precision, relaxing the Rx DSP complexity [124]–[126].

Switching and Bandwidth Granularity in Multi-dimensional networks

Systems utilizing, space on top of frequency and time, add interesting and useful characteristics to the whole network [127]. Firstly, a multi-dimensional network offers great switching capabilities in all three main optical domains [117], [128], [129]. Large amounts of traffic can be switched in space domain using spatial multiplexed channels, but at the same time wavelength (WDM) and sub-wavelength (TDM) switching can also be supported, as in Fig. 14. When space domain is utilized, spatial superchannels would only need mode/core/fiber switching without any WDM mux/demux, so all the input traffic from a source will go to a certain output or destination node. However, for finer bandwidth granularity, each core can be de-multiplexed into discrete spectrum bands or wavelengths using a BV-WSS, then switched separately and finally aggregated in the output again. Additionally, those spectrum slots can be segregated into even smaller time slices, supporting TDM sub-wavelength switching (Fig. 15). In that case, traffic grooming methods, like time-slot assignment TDM, can also be supported for accommodating even more granulated bandwidth requests. In [130], an elastic multi-dimensional network with AoD (Architecture on Demand) programmable nodes, which are interconnected with different MCFs, is presented. It shows SDM multi-granular switching, supporting bandwidth variable Self-Homodyne spatial superchannels. Various demands are served with dynamic and flexible resource allocation (cores, spectrum slices), taking also into consideration various advanced modulation formats to provide the desired capacity and QoT (Quality of Transport).

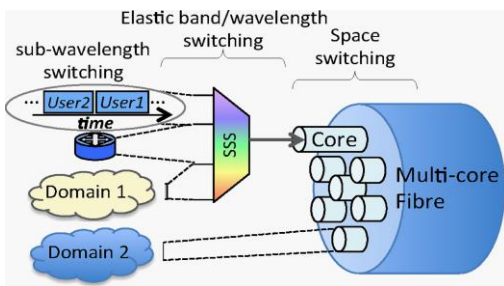

Fig. 14. Multi-dimensional switching using space, frequency and time [128].

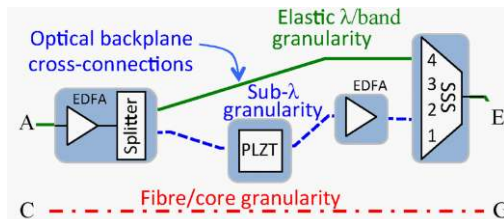

Fig. 15. Example of multi-granular node design. Connection A→E presents elastic wavelength/band and sub-lambda granularity, whereas C→G shows fiber/core granularity instead [128].

Another issue that a multi-dimensional multi-granular network should take care is fragmentation, although space dimension can be used to mitigate spectral fragmentation due to the additional degree of freedom and space switching. Fragmentation happens quite often; repeatedly after demands have been served and the frequency slots that were used are released, new group of demands arrive and need to be setup. However, these do not always fit the previous unassigned frequency slots and as a result spectrum remains unallocated leading in poor network and resources utilization. Defragmentation techniques [131] and routing, spectrum allocation algorithms are being developed (see next section) to ease this issue. For instance, if a contention occurs at a switching node in the frequency or space domain due to fragmentation, one or multiple wavelengths could be converted in some other frequency slots, with a transfer to another spatial mode (core, LP mode, fiber) also being an alternative defragmentation solution.

Routing, Spectrum, Spatial mode and Modulation format Allocation problem

In modern multi-dimensional networks, similarly with classical systems, the control plane has always to run a routing, spectrum, spatial mode and modulation format allocation (RSSMA) algorithm in order to carefully distribute the resources and keep network utilization and blocking in acceptable levels.

Like in traditional optical networks, where wavelength, time-slot (for groomed traffic) and waveband continuity is critical in the routing and provisioning stage, SDM networks have to additionally consider and deal with spatial mode continuity (i.e. LP modes in MMF/FMF, OAM modes in vortex fibers and fiber cores in tightly-coupled MCFs). When requests with certain bandwidth demand arrive to a node, the network has to assign a piece of the spectrum (resource allocation) to each request and find an

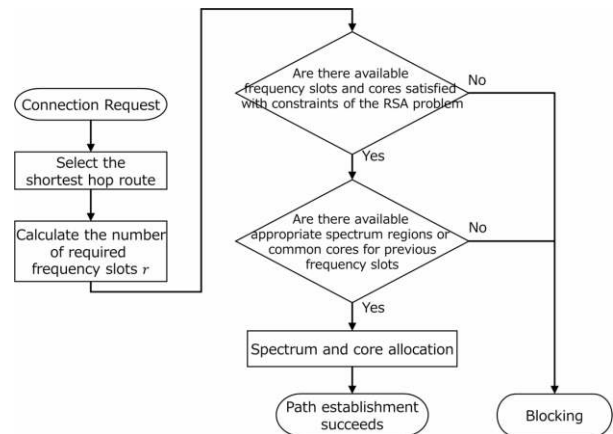

Fig. 16. Routing, Spectrum and Core Allocation algorithm flowchart for an on demand path provisioning [135]

available physical path to the destination node (routing). The introduction of a third space dimension to this operation certainly adds more flexibility and capacity, it adds however routing and allocation complexity too. Most of the times in modern networks, the routing and resource allocation algorithms find the optimum among tens of possible paths and assign the most suitable and efficient combination of modulation format (i.e. OOK, QPSK, DP-QPSK, QAMs etc.) and bandwidth (i.e. 12.5, 25, 50, 100GHz etc) to each request. Many factors, like signal integrity, link distance and QoT, and the trade-offs between them are analyzed by those algorithms to select the best and most efficient option. For instance, in an elastic optical SDM network scenario, a demand from node A to node B arrives and requests a certain amount of bandwidth, which can be either accommodated by two DP-16-QAM spectrum slots or four DP-QPSK ones. The RSSMA algorithm should, not only find the shortest paths available, but also check if inter-core/mode crosstalk conditions are fulfilled for a selected route. Then the algorithm has to identify which modulation format is going to be used depending on the distance of the path, the reachability of the signals and the availability in spectrum resources.

Multi-core fiber seems to be more popular in the optical networking community till now, mostly due to its simpler design, concept and practicality. For that reason, the

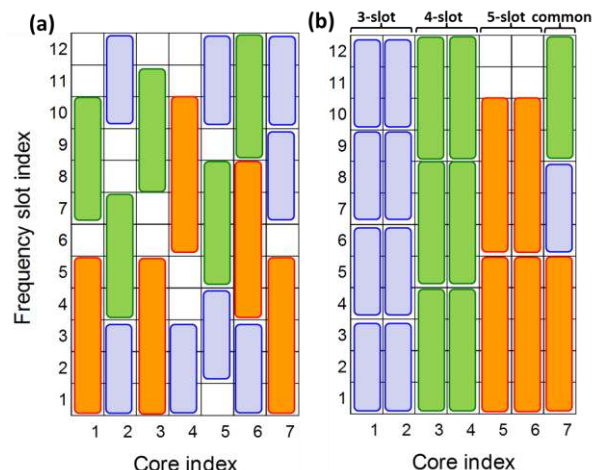

Fig. 17. Example of spectrum utilization in a 7-core fiber with (a) No classification and (b) Pre-defined core classification [136]

RSSMA problem has been tackled by researchers by proposing several algorithms and by simulations [119], [132]–[136] usually regarding MCFs. These methods, as seen in the flowchart of Fig. 16, *i*) firstly manage the routing in the SDM network by selecting the shortest path, then *ii*) calculate the number of frequency slots that are required to accommodate the required bandwidth of the demand and *iii*) check for availability in network resources in order to allocate the available bandwidth, in terms of spectrum and cores of a MCF, taking also into account other constraints like inter-core crosstalk interference.

Apart from the trivial random and first fit techniques, there are several other more advanced approaches for spectrum and core allocation. Some of those prioritize better spectrum utilization and defragmentation, other give more weight in inter-core crosstalk minimization (crosstalk aware spectrum and core assignment algorithms) and some try to achieve a combination of both the above. In [135], [136] two novel spectrum and allocation concepts are proposed. The first one is targeting crosstalk optimization in the MCF links while provisioning the requested resources. The suggested algorithm runs a pre-defined crosstalk-aware prioritization policy by selecting non-adjacent cores for new incoming requests and by allocating the required spectrum there. In that manner, inter-core crosstalk is reduced assuming that crosstalk interference only occurs when the same spectrum slot is used in one or more neighboring cores of a MCF. The second spectrum and allocation concept is based on pre-defining spectrum regions for each class of requested bandwidth. These spectrum regions can be arranged and realized in a per core basis or throughout all the cores of a MCF. The idea is to pre-allocate spectrum regions for each set of demands, i.e. 3-slot, 4-slot, 5-slot regions, as presented in Fig. 17(b). The remaining core will serve as a common core and will be used for the demands that cannot fit in any other pre-defined region, compensating in a sense the unpredictable variation of traffic demands. That spectrum and core allocation model also avoids fragmentation since each region accommodates only connections requiring same bandwidth or number of spectrum slots. Simulations of the above and similar [133] spectrum and core assignment techniques have shown significant enhancement compared to classical Random and First-fit approaches in matter of request blocking probability, inter-core crosstalk effects and of course network resources utilization.

C. Study on existing and future MCFs for various network use-cases

As mentioned in previous sections, MCFs are the most popular SDM fiber structures and there is a lot of ongoing research on these. In fact, the principles behind the MCF design are completely distinctive of the SMF ones. Researchers have been looking into fundamental design aspects, like efficient placement of the cores for reduced inter-core crosstalk, bending losses and cladding thickness [15], [23], [25]–[28]. Obviously, the challenge here is to pack as many cores as possible into a single fiber structure, while avoiding large penalties from inter-core interference.

Bearing this in mind it is important to investigate how many cores could fit in a MCF and then link those MCFs with different kinds of networks and use-cases. This is what we will show in the following part, by simulating crosstalk (XT) for two popular MCF implementations, the first one with 7 cores [15] and the second with 19 cores [23]. Inter-core crosstalk interference in MCFs is defined as the ratio of the optical power inserted from adjacent cores to the one under study, divided by the power of the signal already in that core and it is measured in dB. The threshold, beyond of which the signal integrity is altered, can vary between -18 dB and -32 dB, depending in the modulation format that is used [137]. In our simulations, we use a threshold of around -24dB, which is in the middle of this range and also represents a signal modulated with 16-QAM. To calculate the statistical mean XT of a homogenous MCF, we used a formula based on Eq. (3) as in [15], [138]–[140], which also considers the coupled-power theory [26], leading to Eq. (4).

$$h = \frac{2 \cdot \kappa^2 \cdot R}{\beta \cdot D} \quad (3)$$

$$XT = \frac{n - n \cdot \exp\left(-\frac{(n+1) \cdot 2 \cdot h \cdot L}{n}\right)}{1 + n \cdot \exp\left(-\frac{(n+1) \cdot 2 \cdot h \cdot L}{n}\right)} \quad (4)$$

In Eq. (3), h is the mean crosstalk increase per unit length, calculated by several fiber parameters: κ , β , R , D which is the coupling coefficient, propagation constant, bend radius and core-pitch respectively. Eq. (4) makes use of h from previous equation multiplied by L as the length of the fiber, while n stands for the number of adjacent cores in a hexagonal lattice. For instance, studying the center core of the fiber would require a value of $n=6$. For this simulation, we made some as realistic as possible assumptions about the values of these parameters. Thus, κ is ranging from 2×10^{-5} to $3,5 \times 10^{-3}$, R is ranging from 50 to 80mm, β is 4×10^6 around the 1550nm frequency window and D is $45 \mu\text{m}$ for the 7-core and $35 \mu\text{m}$ for the 19-core. While core-pitch is reduced, i.e. $D < 35 \mu\text{m}$, to investigate theoretical fiber designs, coupling coefficient rises and takes values of $\kappa > 10^{-3}$ [141].

The worst case of crosstalk will always be that of the center core (or any other core that has the largest number of neighbor cores), when studying hexagonal design MCFs, since it receives unwanted interference from all its adjacent

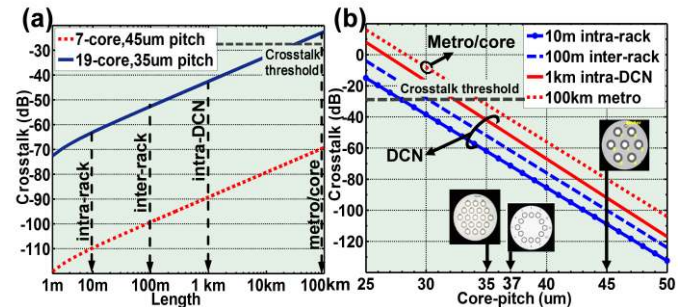

Fig. 18. (a) Crosstalk vs Length for two popular MCF implementations, 7-core and 19-core, with $45 \mu\text{m}$ and $35 \mu\text{m}$ core-pitch respectively. (b) Crosstalk vs Core-pitch for four different links with discrete lengths. Insets show 19-core [23], 12-core [16] and 7-core [15] fiber cross-sections

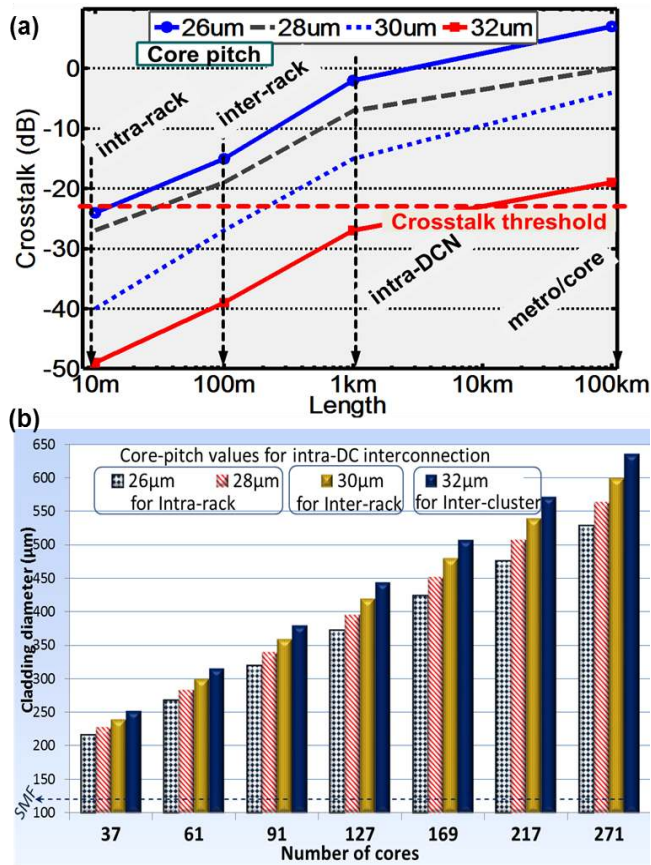

Fig. 19. (a) Crosstalk vs Length for various reduced core-pitches $<35\mu\text{m}$, including network use-cases for diverse link distances (b) Number of cores vs cladding diameter of theoretical MCFs with reduced core-pitch for several intra-DC scenarios

cores. So, the whole SDM link length is often restricted by this core's crosstalk value. At that point, it is worth mentioning that crosstalk interference takes place only between same frequency slices used in adjacent cores. In our simulation, we assume that the spectrum of each core is fully utilized. As stated in a previous part of this paper, there are spectrum and core allocation algorithms which target in minimizing this crosstalk interference of the MCF link [132]–[134]. In Fig. 18(a) crosstalk values for the two MCFs are plotted regarding the link length from 1 m up to 100 km. It is obvious that for most of the network use-cases or interconnection distances, these fibers' XT values are quite below the crosstalk threshold, which leaves a lot room for improvement towards packing more and less-spaced cores within a MCF.

The target is to have as many cores as possible, with the smallest achievable fiber cross-section area and the minimum XT value for the longest propagation distance that is feasible. Reduction of the fiber core-pitch, immediately raises XT, consequently the link length gets limited. But how long need those SDM links to be? The answer stems from the network itself. It depends on the length of the connection and the nature of the network. For instance, separate network types have unique interconnection distances, such as metro/core and intra-datacenter interconnects. In the former case, links need to be in the scale of several hundreds of kilometers ($\geq 100\text{km}$), whereas in the latter case, up to 10 meter links could be

used for intra-rack interconnection, around 100 meters for inter-rack intra-cluster communication and 1 or very few kilometers for inter-cluster and generally intra-DCN connections. As a result, the tradeoff between the core-pitch and the length of the link needs to be investigated further. In Fig. 18(b), XT for four discrete link distance curves and for various core-pitches is presented.

The graph in Fig. 18(b), confirms the argument that there is possibility for shortening the core-pitch even more, since for values less than $35\mu\text{m}$ it seems that some links are still not affected by XT interference. To take it one step further, we studied via simulation the XT values of theoretical multicore fibers with core-pitches of 26, 28, 30 and $32\mu\text{m}$, as depicted in Fig. 19(a). Once again, for a XT threshold of -24dBm , MCFs with 26 or $28\mu\text{m}$ core-pitch could be utilized for short intra-rack (10m) links, connecting servers of the same rack offering several channels with high-capacity and low latency. Other MCFs with $30\mu\text{m}$ could be utilized for inter-rack intra-cluster (100m) communication and still not being affected by XT. For longer ($\geq 1\text{km}$) distances, $32\mu\text{m}$ core-pitch MCF could be deployed, interconnecting different clusters inside a datacenter, depending on the topology of the datacenter network (DCN). For metro/core networks, SDM links based on MCFs with reduced core-pitches are limited by XT after approximately 10km. That would be feasible if XT limit was to rise to -18dBm by using lower modulation formats. Same applies to shorter links as well.

Then, in Fig. 19(b), considering once again the hexagonal MCF design, we calculated the cladding diameters for theoretical MCFs offering 37, 61, 91, 127, 169, 217 and even 271 cores correlating to the different core-pitch values for the various crosstalk-dependent interconnection links of Fig. 19(a). Compared to the theoretical fiber designs of Table I in section III.A, where for 169 cores with a core-pitch value of $35\mu\text{m}$ the MCF had $550\mu\text{m}$ cladding diameter, the design with the reduced core-pitch, i.e. $26\mu\text{m}$, demonstrates $425\mu\text{m}$ cladding diameter for the same number of cores. Of course in any case we recognize that extremely big cladding diameters might perturb the fundamental physical characteristics of the fibre structure.

In conclusion, in a future datacenter scenario, there could be two different servers, each one equipped with tens of CPU cores, that are all-optical interconnected with a 61-core MCF (with a cladding diameter of $\sim 250\mu\text{m}$, which is the practical maximum for optical fibers). In such case, parallel high-bitrate streams could be accommodated by separate MCF cores, serving any kind of server-to-server capacity demand.

D. Core and Metro Networks

Metro-core networks interconnect nodes in distances of 10s/100s km and are supporting traffic from many different applications, such as business data, Web browsing, peer-to-peer, storage networking, utility computing, and new real-time applications such as live video streaming, VoIP, etc.

Requirements

The present and future requirements of core and metro networks are pushing current deployed infrastructure to the limits [142]. Except from high capacity (Tb/s and even Pb/s

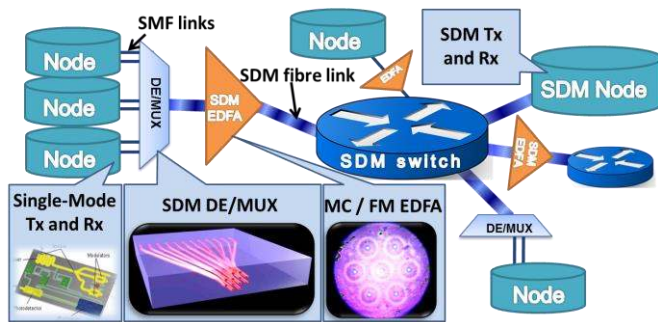

Fig. 20. A spatial multiplexed metro/core network with the necessary SDM components (mux/demux, amplifiers, switches), and links

will soon be required), transport networks need to be scalable to accommodate higher traffic load without requiring large-scale redesign and/or major deployment of resources. They also need to be highly reconfigurable, in order to change the status of some or all of the established connections (add/drop nodes), to modify the parameters and the routing of these connections. Moreover, those networks should be characterized by interoperability, cost-effectiveness, optical and bit-level transparency, and finally resilience, in order to react to network failures, providing backup solutions to restore the connections affected by any failure. Finally, in the transport layer, amplification plays a very important role in this kind of networks, since the links are usually quite long and the propagation losses need to be frequently compensated to keep the signal's integrity.

How can SDM meet those requirements?

As presented in the first part of this paper, SDM technologies are quite mature to successfully cope with most of these challenges (Fig. 20). Indeed, there is a wide variety of SDM fibers [7]-[56] to serve the metro/core network capacity demands and depending on those demands it is possible to make use of the SSE figure of merit to identify which fiber suits better. The transition from an SMF-based infrastructure to the SDM era, would also involve spatial multiplexers and de-multiplexers [68]-[86]. In addition, a lot of SDM amplifier solutions have been developed and proposed for MCF, FMF and other uses [57]-[67]. Of course, there is progress still to be made in order to end up with a reliable solution. When it comes to switching re-configurability, SDM ROADM experimental prototypes have been already presented to offer scalability and successfully deal with loads of WDM and SDM channels [114], [115], [120]. ROADMs are often the most crucial elements of metro/core networks, since they are the main interconnection nodes between sub-networks connecting cities, datacenters etc. Thus it is an absolute necessity to have some solid SDM implementations to rely on for the future multidimensional networks. One of the migration challenges, from current infrastructure to the new SDM era, is the fact that metro/core is mostly brown field. However SDM technologies, such as amplifiers, de-mux, ROADMs, are inversely compatible with fiber-bundles currently used. Finally, resilience and failure recovery functions can be supported by an SDM network, since there are a lot spatial channels in parallel and if for any reason a channel fails,

then its adjacent can replace it instantly.

E. Data Center Networks (DCN)

On top of the physical deployment of computational, storage and network resources, known as a Data Center, a wide range of application is running, from financial and e-commerce to scientific operations. The latest trend is towards "Cloud Computing", where end-users are given the opportunity to run any of the above applications remotely inside a DC. It is obvious that this can only be realized with the support of high-performance networks inside and between datacenters. As a result, Big Data and massive storage clouds are the critical points that future data centers need to consider.

Requirements

Emerging Data Centers will need to accommodate from 10s to 100 of thousands of servers to provide the necessary computational power and storage space needed for the operation of mainly cloud-based functions. It is obvious that these servers, which are usually organized in racks and clusters, need to communicate vastly, either for long or for very short periods of time, always depending on the type of application [143]. From the above it is also obvious that high capacity, low power consumption, fiber complexity, scalability and low latency are important requirements for intra Data Center Networks [144], [145].

Current DCNs utilize optical fibers (mostly MMF), but not in the most efficient way. Some intra-DCN physical connections are really hard to manage due to the extreme fiber complexity and fiber count. Another essential aspect usually to consider is the restricted space inside a data center. While everything is organized in racks, the area and volume for each server, switch or any other network component is finite and pre-arranged. That is because the data center needs to be strictly systematic in order to ease thermal management and central control. Currently, for transmission rates of 10Gbaud and short distances (1-2km) intra data center, direct modulation with On-Off Keying (OOK) is used, since it is simple, low-power and cost-effective. However, for future DC interconnection with requirements of more than 100Gb/s (10×10G or 4×25G) and 1Tb/s (32×25G or 10×100G) [146], novel modulation schemes, a mix of TDM-SDM-WDM and digital signal processing (DSP) might be unavoidable. At last, from a financial perspective, the purchase cost of the infrastructure along with the maintenance expenses, seems to be an

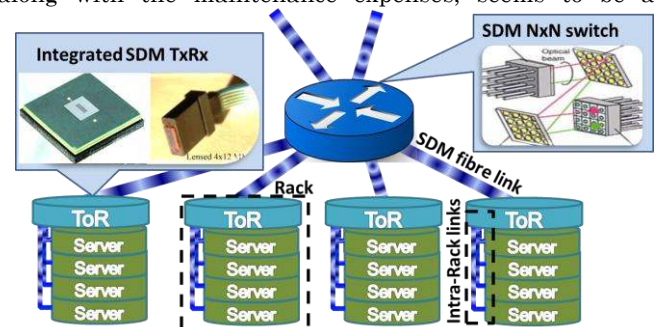

Fig. 21. A spatial multiplexed data center network. Servers and racks are interconnected with SDM links and SDM network devices are used for transmission/reception, switching etc.

equally deciding factor for the developing of future DCs.

How can SDM meet those requirements?

SDM can address these requirements to a large extent and improve the interconnection between the servers of the datacenter in quite a few ways. Firstly, with a single SDM fiber, MCF or other, the same and even higher capacity and spectral-spatial efficiency can be achieved, than deploying multiple single-core fibers. Recently, an all-optical scalable intra-DCN interconnect using SDM (Multi-Element Fibers) in collaboration with TDM (PLZT-based, SOA-based switches) for finer granularity was experimentally demonstrated, offering ToR-to-ToR intra- and inter-cluster communication [147]. In that way, cable density between racks is decreased dramatically too, resulting in a more relaxed spacing and finally easier cooling of the whole network system. Furthermore, highly-integrated SDM network devices, like TxRx that enable direct coupling with SDM fibers, save useful space inside the DC racks and also resources, leading in an increase of energy efficiency [148], without compromising performance. Low power consumption could be achieved if a SDM-only architecture was adopted, instead of WDM-SDM. Then, firstly no WDM mux/demux would be necessary, and secondly with the use of low-cost low-power consumption grey interface VCSELs in different SDM channels of an SDM fiber, the required capacity and energy efficiency targets could be met (Fig 21). For latency sensitive DCN cases, for instance High Performance Computing (HPC), all-optical switches in Top of the Rack (ToR) and in other places of the DCN could be utilized along with HC-PBGF, in order to avoid O/E/O conversion and provide ultra-low latency light-paths between processing, memory and storage racks. In addition, TDM ultra-fast switches of the nanosecond scale could cooperate greatly with SDM fibers too and add the necessary granularity for switching short-live data bursts. Finally, as far as cost-efficiency is concerned, we need to examine whether plain cost is a good metric for designing a DCN or if it would be better to consider cost per Gbps of network/link capacity. In that case, SDM could prove quite cost-efficient as well.

V. CHALLENGES OF SDM AND FUTURE DIRECTIONS OF RESEARCH

In the previous sections, numerous capabilities of SDM technologies and aspects of SDM networking have been presented and thoroughly analyzed. There was also a brief discussion on how metro/core, access and DC networks could potentially benefit from SDM networking. Research gaps, lessons learned and directions of where SDM research should focus in the future are discussed in this part of the paper. In order to provide a more complete and combined vision of SDM technologies and techniques, Fig. 22 summarizes the challenges and potential solutions associated with various kinds of networks (backbone, metro/region and DC/HPC).

Regarding long-haul backbone networks, consisting of 1000km long links, obvious challenges for SDM solutions would be mode coupling and crosstalk as well as amplification. MCFs could be a more reliable solution since

a lot of work has been done in minimizing inter-core crosstalk interference. Mode-multiplexing, using MMF/FMF or even vortex fiber for OAM multiplexing, in such distances is almost impossible. According to previous studies [149]–[151], optical signals and their OSNR would be strongly affected and degraded by modal dispersion, mode dependent loss and differential mode delay, that even heavy MIMO-DSP in the receiver side would not be enough to recover it properly. However, Few-Mode MCF could be one feasible alternative for long-haul networks that researchers should look upon in the future. As far as SDM amplifiers are concerned, it is clear that their frequent use is absolutely essential in long-haul distances so more efficient solutions need to be produced. SDM transponders and mux/demux in backbone and metro network nodes, do not have any special restriction as far as integration and power consumption is concerned in comparison with datacenter and HPC networks where footprint and energy efficiency are both major and decisive factors.

Moreover, regarding backbone and metro networks, novel SDM amplifiers, especially those based on cladding-pumping, are backward compatible with current SMF-based network infrastructure and lead to increased integration, cutting down in resources (i.e. one EDFA instead of multiple) and eventually in great power savings. Of course issues like power and gain balancing are still to be solved.

Another important challenge for SDM, is how it can prove itself worthy enough to network vendors, owners and service providers in order for them to introduce its technologies and solutions and possibly integrate them in their present infrastructure. Further studies are required to justify the benefits and establish the merits of SDM correlated with the various network use-cases. A meaningful first step would be the standardization of fibers and other SDM technologies in order to accelerate research to deployment cycles. The ultra-high bandwidth that novel SDM fibers are able to provide, the integration of SDM components (EDFAs, TxRx, mux/demux, etc.) along with the additional level of flexibility in routing and switching the space dimension offers are expected to be among the predominant drivers for future research on this field.

Great potential for easy and direct SDM network deployment can be found in newly-built smart cities. These cities are a green field for real life testing of the SDM technologies with realistic traffic flows and bitrates. Smart cities in that way could undoubtedly give researchers a great chance to setup a whole SDM network infrastructure from scratch and observe its behavior while serving a modern's city's actual networking needs.

Nevertheless, besides the increased capacity and the additional networking features that SDM can offer and are presented in the above sections, the utilization of the space dimension could also open new opportunities and bring potential for optical network virtualization, in example by allocating numerous virtual slices over distinct spatial modes.

VI. CONCLUSION

SDM fibers and network components were reviewed and evaluated using the proposed SDM FoMs. Then, certain aspects of SDM were analyzed from a networking perspective, followed by our study on MCF fibers, which

SDM technologies & networking aspects	Backbone networks	Metro/region networks	Intra-Datacenter/HPC networks	
SDM fibers	fiber bundle/ ribbon	low SSE	low SSE	low SSE
		commercially used	commercially used	commercially used
		low integration	low integration	medium integration
	multi-core fibre (MCF)	high SSE	high SSE	high SSE
		high crosstalk	medium crosstalk	low crosstalk
		low integration	medium integration	high integration
	multi/few mode fiber (MMF/FMF)	medium SSE	medium SSE	medium SSE
		high crosstalk, DMD, modal dispersion	medium crosstalk, DMD, modal dispersion	low crosstalk, DMD, modal dispersion
		heavy MIMO-DSP	light MIMO-DSP	no MIMO-DSP
	few mode - multi-core fiber (FM-MCF)	high SSE	high SSE	high SSE
		medium crosstalk, DMD, modal dispersion	medium crosstalk, DMD, modal dispersion	low crosstalk, DMD, modal dispersion
		light MIMO-DSP	light MIMO-DSP	no MIMO-DSP
	vortex fiber for orbital angular momentum	reduced modal interference compared to few-mode fibers		low modal interference
		medium SSE (potentially high depending on the number of OAM modes)		
		MIMO-DSP probably required		no MIMO-DSP
amplifiers	high energy efficiency by cladding pumping		- amplifiers not desirable in DC/HPC networks -	
	cost efficient - using only one EDFA module to amplify multiple spatial modes			
	backwards compatible with current network infrastructure			
fan-in/out, mux/demux	low integration	low integration	high integration	
	medium loss	medium loss	low loss	
	footprint not a restrictive factor	footprint not a restrictive factor	small footprint	
transceivers / transponders	low integration	medium integration	high integration	
	footprint not a restrictive factor	footprint not a restrictive factor	high integration	
	footprint not a restrictive factor	need for low-cost pluggables for multi-layer alien-waves and black links	small footprint	
	normal energy efficiency	normal energy efficiency	high energy efficiency	
	self-homodyne coherent detection for advanced modulation formats	self-homodyne coherent detection for advanced modulation formats	direct detection for simple modulation formats	
switching / ROADMs	multi-dimensional switching (space and/or frequency)	multi-dimensional switching (space and/or frequency and/or time)	multi-dimensional switching (space and/or frequency and/or time)	
	coarse granularity (add/drop multiple cores/modes)	coarse & fine granularity (add/drop one or multiple cores/modes)	coarse & ultra-fine granularity (fast space/frequency switching)	
	filter-based nodes	filtered or filterless-based nodes (low complexity)	limited cost & complexity with high degree of scalability and modularity	
routing, spectrum, spatial mode, modulation format allocation	less frequent need for resource allocation	frequent need for resource allocation	very frequent need for resource allocation	
	static traffic with normal complexity	static or semi-dynamic traffic with normal or higher complexity	high complexity: orchestrate network with compute, storage and memory resources	

Fig. 22. Summary of SDM technologies, networking aspects with their associated features and requirements for backbone, metro/region and datacenter/high-performance computing networks

introduced new fiber designs for various networks, taking into consideration the inter-core crosstalk and the network link nature. Finally, we discussed the existing and future requirements of core, metro and datacenter networks and

then linked those with the available SDM technologies. SDM is truly a very promising technology but progress needs to be made before SDM becomes an established technology. This refers both to SDM technology and in SDM

networking, Hardware-wise, there are still gaps in development of i.e. fully-SDM-enabled switches and TxRx. Same applies for the SDM networking, where realistic efficient algorithms for SDM routing and resource allocation compared with WDM/TDM are still to be investigated deeper.

APPENDIX

The centered hexagonal number (also known as hex number) is a sequential number drawn from mathematics and geometry and his purpose is to fit as many dots in a circular area (where, in our case, dots and circular area are cores and fiber cross-section respectively) [152]. The number of cores that can fit in a fiber is calculated by this centered hexagonal number sequence:

$$3 \cdot n \cdot (n-1) + 1, \text{ for } n = 1, 2, 3, 4, 5, \dots$$

The first few centered hexagonal numbers are 1, 7, 19, 37, 61, 91, 127, 169, 217 ...

REFERENCES

- [1] R. W. Tkach, "Network Traffic and system capacity: Scaling for the future," in *2010 36th European Conference and Exhibition on Optical Communication (ECOC)*, 2010, pp. 1–22.
- [2] R.-J. Essiambre and R. W. Tkach, "Capacity Trends and Limits of Optical Communication Networks," *Proc. IEEE*, vol. 100, no. 5, pp. 1035–1055, May 2012.
- [3] R. W. Tkach, "Can optical communications continue to meet the demand for bandwidth?," in *Opto-Electronics and Communications Conference (OECC), 2012 17th*, 2012, pp. 551–552.
- [4] R. Essiambre, G. Kramer, P. J. Winzer, G. J. Foschini, and B. Goebel, "Capacity Limits of Optical Fiber Networks," *J. Light. Technol.*, vol. 28, no. 4, pp. 662–701, Feb. 2010.
- [5] R. J. Mears, L. Reekie, I. M. Jauncey, and D. N. Payne, "Low-noise erbium-doped fibre amplifier operating at 1.54 μm ," *Electron. Lett.*, vol. 23, no. 19, pp. 1026–1028, Sep. 1987.
- [6] D. J. Richardson, J. M. Fini, and L. E. Nelson, "Space-division multiplexing in optical fibres," *Nat. Photonics*, vol. 7, no. 5, pp. 354–362, Apr. 2013.
- [7] S. Inao, T. Sato, S. Sentsui, T. Kuroha, and Y. Nishimura, "Multicore optical fiber," in *WBI*, 1979, vol. 46–8.
- [8] S. Berdague and P. Facq, "Mode division multiplexing in optical fibers," *Appl. Opt.*, vol. 21, no. 11, pp. 1950–1955, 1982.
- [9] P. Boffi, P. Martelli, A. Gatto, and M. Martinelli, "Mode-division multiplexing in fibre-optic communications based on orbital angular momentum," *J. Opt.*, vol. 15, no. 7, p. 075403, 2013.
- [10] "Sumitomo Electric." [Online]. Available: <http://www.sumitomoelectric.com/>.
- [11] "OFS." [Online]. Available: <http://www.ofsoptics.com/>.
- [12] "Avago Technologies." [Online]. Available: <http://www.avagotech.com/>.
- [13] "Samtec." [Online]. Available: <http://www.samtec.com/>.
- [14] "Reflex Photonics." [Online]. Available: <http://www.reflexphotonics.com/>.
- [15] T. Hayashi, T. Taru, O. Shimakawa, T. Sasaki, and E. Sasaoka, "Design and fabrication of ultra-low crosstalk and low-loss multi-core fiber," *Opt. Express*, vol. 19, no. 17, pp. 16576–16592, 2011.
- [16] H. Takara, A. Sano, T. Kobayashi, H. Kubota, H. Kawakami, A. Matsuura, Y. Miyamoto, Y. Abe, H. Ono, K. Shikama, and others, "1.01-Pb/s (12 SDM/222 WDM/456 Gb/s) crosstalk-managed transmission with 91.4-b/s/Hz aggregate spectral efficiency," in *European Conference and Exhibition on Optical Communication*, 2012.
- [17] T. Hayashi, T. Nakanishi, K. Hirashima, O. Shimakawa, F. Sato, K. Koyama, A. Furuya, Y. Murakami, and T. Sasaki, "125- μm -Cladding 8-Core Multi-Core Fiber Realizing Ultra-High-Density Cable Suitable for O-Band Short-Reach Optical Interconnects," in *Optical Fiber Communication Conference*, 2015, p. Th5C–6.
- [18] A. Sano, H. Takara, T. Kobayashi, H. Kawakami, H. Kishikawa, T. Nakagawa, Y. Miyamoto, Y. Abe, H. Ono, K. Shikama, M. Nagatani, T. Mori, Y. Sasaki, I. Ishida, K. Takenaga, S. Matsuo, K. Saitoh, M. Koshiha, M. Yamada, H. Masuda, and T. Morioka, "409-Tb/s + 409-Tb/s crosstalk suppressed bidirectional MCF transmission over 450 km using propagation-direction interleaving," *Opt. Express*, vol. 21, no. 14, p. 16777, Jul. 2013.
- [19] M.-J. Li, B. Hoover, V. N. Nazarov, and D. L. Butler, "Multicore fiber for optical interconnect applications," in *Opto-Electronics and Communications Conference (OECC), 2012 17th*, 2012, pp. 564–565.
- [20] O. N. Egorova, S. L. Semjonov, A. K. Senatorov, M. Y. Salganskii, A. V. Koklyushkin, V. N. Nazarov, A. E. Korolev, D. V. Kuksenkov, M.-J. Li, and E. M. Dianov, "Multicore fiber with rectangular cross-section," *Opt. Lett.*, vol. 39, no. 7, p. 2168, Apr. 2014.
- [21] S. Matsuo, K. Takenaga, Y. Arakawa, Y. Sasaki, S. Taniagwa, K. Saitoh, and M. Koshiha, "Large-effective-area ten-core fiber with cladding diameter of about 200 μm ," *Opt. Lett.*, vol. 36, no. 23, pp. 4626–4628, 2011.
- [22] K. Takenaga, Y. Arakawa, S. Tanigawa, N. Guan, S. Matsuo, K. Saitoh, and M. Koshiha, "Reduction of crosstalk by trench-assisted multi-core fiber," in *Optical Fiber Communication Conference*, 2011, p. OWJ4.
- [23] J. Sakaguchi, B. J. Puttnam, W. Klaus, Y. Awaji, N. Wada, A. Kanno, T. Kawanishi, K. Imamura, H. Inaba, K. Mukasa, and others, "305 Tb/s Space Division Multiplexed Transmission Using Homogeneous 19-Core Fiber," *J. Light. Technol.*, vol. 31, no. 4, pp. 554–562, 2013.
- [24] J. Sakaguchi, W. Klaus, B. J. Puttnam, J. M. D. Mendinueta, Y. Awaji, N. Wada, Y. Tsuchida, K. Maeda, M. Tadakuma, K. Imamura, R. Sugizaki, T. Kobayashi, Y. Tottori, M. Watanabe, and R. V. Jensen, "19-core MCF transmission system using EDFA with shared core pumping coupled via free-space optics," *Opt. Express*, vol. 22, no. 1, p. 90, Jan. 2014.
- [25] K. Takenaga, Y. Arakawa, Y. Sasaki, S. Tanigawa, S. Matsuo, K. Saitoh, and M. Koshiha, "A large effective area multi-core fiber with an optimized cladding thickness," *Opt. Express*, vol. 19, no. 26, pp. B543–B550, 2011.
- [26] S. Koshiha and M. Takenaga, "Multi-core fiber design and analysis: coupled-mode theory and coupled-power theory," *Opt. Express*, vol. 19, no. 26, 2011.
- [27] Y. Sasaki, Y. Amma, K. Takenaga, S. Matsuo, K. Saitoh, and M. Koshiha, "Investigation of Crosstalk Dependencies on Bending Radius of Heterogeneous Multicore Fiber," in *Optical Fiber Communication Conference*, 2013.
- [28] T. Ito, E. Le Taillandier de Gabory, M. Arikawa, Y. Hashimoto, and K. Fukuchi, "Reduction of Influence of Inter-core Cross-talk in MCF with Bidirectional Assignment between Neighboring Cores," in *Optical Fiber Communication Conference*, 2013.
- [29] "RP Photonics - Fibers." [Online]. Available: <http://www.rp-photonics.com/fibers.html>.
- [30] N. K. Fontaine, R. Ryf, H. Chen, A. V. Benitez, B. Guan, R. Scott, B. Ercan, S. J. B. Yoo, L. E. Grüner-Nielsen, Y. Sun, and others, "30 \times 30 MIMO Transmission over 15 Spatial Modes," in *Optical Fiber Communication Conference*, 2015, p. Th5C–1.
- [31] M. Bigot-Astruc, D. Boivin, and P. Sillard, "Design and fabrication of weakly-coupled few-modes fibers," in

- Photonics Society Summer Topical Meeting Series, 2012 IEEE*, 2012, pp. 189–190.
- [32] T. Mori, T. Sakamoto, M. Wada, T. Yamamoto, and F. Yamamoto, “Six-LP-mode transmission fiber with DMD of less than 70 ps/km over C+L band,” in *Optical Fiber Communications Conference and Exhibition (OFC), 2014*, 2014, pp. 1–3.
- [33] R. Ryf, S. Randel, A. H. Gnauck, C. Bolle, A. Sierra, S. Mumtaz, M. Esmaelpour, E. C. Burrows, R.-J. Essiambre, P. J. Winzer, D. W. Peckham, A. H. McCurdy, and R. Lingle, “Mode-Division Multiplexing Over 96 km of Few-Mode Fiber Using Coherent 6 x 6 MIMO Processing,” *J. Light. Technol.*, vol. 30, no. 4, pp. 521–531, Feb. 2012.
- [34] V. Sleiffer, Y. Jung, V. Veljanovski, R. van Uden, M. Kuschnerov, H. Chen, B. Inan, L. G. Nielsen, Y. Sun, D. J. Richardson, and others, “73.7 Tb/s (96 x 3 x 256-Gb/s) mode-division-multiplexed DP-16QAM transmission with inline MM-EDFA,” *Opt. Express*, vol. 20, no. 26, pp. B428–B438, 2012.
- [35] V. Sleiffer, H. Chen, Y. Jung, P. Leoni, M. Kuschnerov, A. Simperler, H. Fabian, H. Schuh, F. Kub, D. Richardson, and others, “Field demonstration of mode-division multiplexing upgrade scenarios on commercial networks,” *Opt. Express*, vol. 21, no. 25, pp. 31036–31046, 2013.
- [36] K. Mukasa, K. Imamura, and R. Sugizaki, “Multi-core few-mode optical fibers with large Aeff,” in *European Conference and Exhibition on Optical Communication*, 2012.
- [37] C. Xia, R. Amezcua-Correa, N. Bai, E. Antonio-Lopez, D. May-Arrijo, A. Schulzgen, M. Richardson, J. Liñares, C. Montero, E. Mateo, and others, “Hole-assisted few-mode multi-core fiber for high-density space-division multiplexing,” in *Photonics Society Summer Topical Meeting Series, 2012 IEEE*, 2012, pp. 206–207.
- [38] K. Takenaga, Y. Sasaki, Ning Guan, S. Matsuo, M. Kasahara, K. Saitoh, and M. Koshiba, “Large Effective-Area Few-Mode Multicore Fiber,” *IEEE Photonics Technol. Lett.*, vol. 24, no. 21, pp. 1941–1944, Nov. 2012.
- [39] Y. Sasaki, K. Takenaga, S. Matsuo, K. Saitoh, and M. Koshiba, “Trench-assisted low-crosstalk few-mode multicore fiber,” in *Optical Communication (ECOC 2013), 39th European Conference and Exhibition on*, 2013, pp. 1–3.
- [40] R. G. H. van Uden, R. A. Correa, E. A. Lopez, F. M. Huijskens, C. Xia, G. Li, A. Schulzgen, H. de Waardt, A. M. J. Koonen, and C. M. Okonkwo, “Ultra-high-density spatial division multiplexing with a few-mode multicore fibre,” *Nat. Photonics*, vol. advance online publication, Oct. 2014.
- [41] J. Sakaguchi, W. Klaus, J. M. Delgado Mendinueta, B. J. Puttnam, R. S. Luis, Y. Awaji, N. Wada, T. Hayashi, T. Nakanishi, T. Watanabe, and others, “Realizing a 36-core, 3-mode Fiber with 108 Spatial Channels,” in *Optical Fiber Communication Conference*, 2015, p. Th5C–2.
- [42] K. Igarashi, D. Souma, Y. Wakayama, K. Takeshima, Y. Kawaguchi, T. Tsuritani, I. Morita, and M. Suzuki, “114 Space-Division-Multiplexed Transmission over 9.8-km Weakly-Coupled-6-Mode Uncoupled-19-Core Fibers,” in *Optical Fiber Communication Conference*, 2015, p. Th5C–4.
- [43] T. Watanabe and Y. Kokubun, “Over 300 channels uncoupled few-mode multi-core fiber for space division multiplexing,” in *Optical Fiber Communication Conference*, 2014, p. Th2A–50.
- [44] J. Wang, J.-Y. Yang, I. M. Fazal, N. Ahmed, Y. Yan, H. Huang, Y. Ren, Y. Yue, S. Dolinar, M. Tur, and others, “Terabit free-space data transmission employing orbital angular momentum multiplexing,” *Nat. Photonics*, vol. 6, no. 7, pp. 488–496, 2012.
- [45] N. Bozinovic, Y. Yue, Y. Ren, M. Tur, P. Kristensen, A. Willner, and S. Ramachandran, “Orbital angular momentum (OAM) based mode division multiplexing (MDM) over a Km-length fiber,” in *European Conference and Exhibition on Optical Communication*, 2012.
- [46] J. Wang and A. Willner, “Using Orbital Angular Momentum Modes for Optical Transmission,” in *Optical Fiber Communication Conference*, 2014, p. W4J–5.
- [47] N. Bozinovic, Y. Yue, Y. Ren, M. Tur, P. Kristensen, H. Huang, A. E. Willner, and S. Ramachandran, “Terabit-Scale Orbital Angular Momentum Mode Division Multiplexing in Fibers,” *Science*, vol. 340, no. 6140, pp. 1545–1548, Jun. 2013.
- [48] X. Cai, J. Wang, M. J. Strain, B. Johnson-Morris, J. Zhu, M. Sorel, J. L. O’Brien, M. G. Thompson, and S. Yu, “Integrated compact optical vortex beam emitters,” *Science*, vol. 338, no. 6105, pp. 363–366, 2012.
- [49] H. Huang, G. Xie, Y. Yan, N. Ahmed, Y. Ren, Y. Yue, D. Rogawski, M. Tur, B. Erkmen, K. Birnbaum, and others, “100 Tbit/s free-space data link using orbital angular momentum mode division multiplexing combined with wavelength division multiplexing,” in *Optical Fiber Communication Conference*, 2013, p. OTh4G–5.
- [50] null Cregan, null Mangan, null Knight, null Birks, null Russell, null Roberts, and null Allan, “Single-Mode Photonic Band Gap Guidance of Light in Air,” *Science*, vol. 285, no. 5433, pp. 1537–1539, Sep. 1999.
- [51] V. A. J. M. Sleiffer, Y. Jung, N. K. Baddela, J. Surof, M. Kuschnerov, V. Veljanovski, J. R. Hayes, N. V. Wheeler, E. R. N. Fokoua, J. P. Wooller, D. R. Gray, N. H.-L. Wong, F. R. Parmigiani, S. Alam, M. N. Petrovich, F. Poletti, D. J. Richardson, and H. de Waardt, “High Capacity Mode-Division Multiplexed Optical Transmission in a Novel 37-cell Hollow-Core Photonic Bandgap Fiber,” *J. Light. Technol.*, vol. 32, no. 4, pp. 854–863, Feb. 2014.
- [52] P. J. Roberts, F. Couny, H. Sabert, B. J. Mangan, D. P. Williams, L. Farr, M. W. Mason, A. Tomlinson, T. A. Birks, J. C. Knight, and others, “Ultimate low loss of hollow-core photonic crystal fibres,” *Opt. Express*, vol. 13, no. 1, pp. 236–244, 2005.
- [53] V. A. J. M. Sleiffer, Y. Jung, N. K. Baddela, J. Surof, M. Kuschnerov, V. Veljanovski, J. R. Hayes, N. V. Wheeler, E. R. N. Fokoua, J. P. Wooller, D. R. Gray, N. H.-L. Wong, F. R. Parmigiani, S.-U. Alam, M. N. Petrovich, F. Poletti, D. J. Richardson, and H. de Waardt, “High Capacity Mode-Division Multiplexed Optical Transmission in a Novel 37-cell Hollow-Core Photonic Bandgap Fiber,” *J. Light. Technol.*, vol. 32, no. 4, pp. 854–863, Feb. 2014.
- [54] V. A. Sleiffer, P. Leoni, Y. Jung, H. Chen, M. Kuschnerov, S. Alam, M. Petrovich, F. Poletti, N. V. Wheeler, N. Baddela, and others, “Ultra-high capacity transmission with few-mode silica and hollow-core photonic bandgap fibers,” in *Optical Fiber Communication Conference*, 2014, p. Tu2J–3.
- [55] “NKT Photonics.” [Online]. Available: <http://www.nktphotonics.com/>.
- [56] J. Carpenter, J. Xu, C. Peucheret, and T. D. Wilkinson, “Mode multiplexing at 2x 20Gbps over 19-cell hollow-core photonic band gap fibre,” in *Optical Fiber Communication Conference and Exposition (OFC/NFOEC), 2012 and the National Fiber Optic Engineers Conference*, 2012, pp. 1–3.
- [57] R. van Uden, C. Okonkwo, H. Chen, N. V. Wheeler, F. Poletti, M. Petrovich, D. J. Richardson, H. de Waardt, and A. Koonen, “8.96 Tb/s (32x 28GBaudx 32QAM) Transmission over 0.95 km 19 cell Hollow-Core Photonic Bandgap Fiber,” in *Optical Fiber Communication Conference*, 2014, p. W4J–3.
- [58] N. Mac Suibhne, Z. Li, B. Baeuerle, J. Zhao, J. Wooller, S. Alam, F. Poletti, M. Petrovich, A. Heidt, N. Wheeler, N. Baddela, E. R. Numkam Fokoua, I. Giles, D. Giles, R. Phelan, J. O’Carroll, B. Kelly, B. Corbett, D. Murphy, A. D. Ellis, D. J. Richardson, and F. Garcia Gunning, “WDM Transmission at 2µm over Low-Loss Hollow Core Photonic Bandgap Fiber,” in *Optical Fiber Communication Conference/National Fiber Optic Engineers Conference 2013*, 2013, p. OW11.6.
- [59] V. Mikhailov, J. M. Fini, L. Meng, B. Mangan, J. W. Nicholson, R. S. Windeler, E. M. Monberg, F. V. DiMarcello,

- and P. S. Westbrook, "Low-Loss Low-Latency Transmission Over Single-Mode Hollow Core Fiber at 10 and 120 Gb/s," in *Optical Fiber Communication Conference*, 2014, p. M2F-3.
- [60] S. Jain, V. J. F. Ranaño, T. C. May-Smith, P. Petropoulos, J. K. Sahu, and D. J. Richardson, "Multi-Element Fiber Technology for Space-Division Multiplexing Applications," *Opt. Express*, vol. 22, no. 4, p. 3787, Feb. 2014.
- [61] V. J. F. Ranaño, S. Jain, T. C. May-Smith, J. K. Sahu, P. Petropoulos, and D. J. Richardson, "First demonstration of an amplified transmission line based on multi-element fibre technology," 2013.
- [62] S. Jain, T. May-Smith, A. Dhar, A. Webb, M. Belal, D. Richardson, J. Sahu, and D. Payne, "Erbium-doped multi-element fiber amplifiers for space-division multiplexing operations," *Opt. Lett.*, vol. 38, no. 4, pp. 582-584, 2013.
- [63] S. Jain, V. J. F. Ranaño, T. C. May-Smith, P. Petropoulos, J. K. Sahu, and D. J. Richardson, "Multi-element Fiber for space-division multiplexed optical communication system," in *Transparent Optical Networks (ICTON), 2014 16th International Conference on*, 2014, pp. 1-4.
- [64] P. M. Krummrich, "Optical amplifiers for multi mode/multi core transmission," in *Optical Fiber Communication Conference*, 2012, p. OW1D-1.
- [65] R. Ryf, M. A. Mestre, S. Randel, C. Schmidt, A. H. Gnauck, R.-J. Essiambre, P. J. Winzer, R. Delbue, P. Pupalaiakis, A. Sureka, Y. Sun, X. Jiang, D. W. Peckham, A. McCurdy, and R. Lingle, "Mode-Multiplexed Transmission Over a 209-km DGD-Compensated Hybrid Few-Mode Fiber Span," *IEEE Photonics Technol. Lett.*, vol. 24, no. 21, pp. 1965-1968, Nov. 2012.
- [66] H. Takara, H. Ono, Y. Abe, H. Masuda, K. Takenaga, S. Matsuo, H. Kubota, K. Shibahara, T. Kobayashi, and Y. Miaymoto, "1000-km 7-core fiber transmission of 10 x 96-Gb/s PDM-16QAM using Raman amplification with 6.5 W per fiber," *Opt. Express*, vol. 20, no. 9, pp. 10100-10105, Apr. 2012.
- [67] M. Yamada, K. Tsujikawa, L. Ma, K. Ichii, S. Matsuo, N. Hanzawa, and H. Ono, "Optical Fiber Amplifier Employing a Bundle of Reduced Cladding Erbium-Doped Fibers," *IEEE Photonics Technol. Lett.*, vol. 24, no. 21, pp. 1910-1913, Nov. 2012.
- [68] K. S. Abedin, J. M. Fini, T. F. Thierry, V. R. Supradeepa, B. Zhu, M. F. Yan, L. Bansal, E. M. Monberg, and D. J. DiGiovanni, "Multicore Erbium Doped Fiber Amplifiers for Space Division Multiplexing Systems," *J. Light. Technol.*, vol. 32, no. 16, pp. 2800-2808, Aug. 2014.
- [69] Y. Tsuchida, M. Tadakuma, and R. Sugizaki, "Multicore EDFA for space division multiplexing by utilizing cladding-pumped technology," in *Optical Fiber Communications Conference and Exhibition (OFC), 2014*, 2014, pp. 1-3.
- [70] Y. Yung, S. Alam, Z. Li, A. Dhar, D. Giles, I. Giles, J. Sahu, L. Grüner-Nielsen, F. Poletti, and D. Richardson, "First demonstration of multimode amplifier for spatial division multiplexed transmission systems," in *European Conference and Exposition on Optical Communications*, 2011.
- [71] E. E. Lim, Y. Jung, Q. Kang, T. C. May-Smith, N. H. Wong, R. Standish, F. Poletti, J. K. Sahu, S. Alam, and D. J. Richardson, "First Demonstration of Cladding Pumped Few-mode EDFA for Mode Division Multiplexed Transmission," in *Optical Fiber Communication Conference*, 2014, p. M2J-2.
- [72] G. Le Cocq, L. Bigot, A. Le Rouge, G. Bouwmans, H. El Hamzaoui, K. Delplace, M. Bouazaoui, and Y. Quiquempois, "Few mode Er³⁺-doped fiber with microstructured core enabling spectral and modal gain equalization for spatial division multiplexing," in *Optical Communication (ECOC 2013), 39th European Conference and Exhibition on*, 2013, pp. 1-3.
- [73] M. Salsi, D. Peyrot, G. Charlet, S. Bigo, R. Ryf, N. K. Fontaine, M. A. Mestre, S. Randel, X. Palou, C. Bolle, and others, "A six-mode erbium-doped fiber amplifier," in *European Conference and Exhibition on Optical Communication*, 2012, p. Th-3.
- [74] P. M. Krummrich and others, "Cost and energy efficient optical amplifiers for space division multiplexing," 2014.
- [75] W. Klaus, J. Sakaguchi, B. J. Puttnam, Y. Awaji, N. Wada, T. Kobayashi, and M. Watanabe, "Free-Space Coupling Optics for Multicore Fibers," *IEEE Photonics Technol. Lett.*, vol. 24, no. 21, pp. 1902-1905, Nov. 2012.
- [76] Y. Tottori, T. Kobayashi, and M. Watanabe, "Low Loss Optical Connection Module for Seven-Core Multicore Fiber and Seven Single-Mode Fibers," *IEEE Photonics Technol. Lett.*, vol. 24, no. 21, pp. 1926-1928, Nov. 2012.
- [77] J. Sakaguchi, Y. Awaji, N. Wada, A. Kanno, T. Kawanishi, T. Hayashi, T. Taru, T. Kobayashi, and M. Watanabe, "109-Tb/s (7 x 97 x 172-Gb/s SDM/WDM/PDM) QPSK transmission through 16.8-km homogeneous multi-core fiber," in *Optical Fiber Communication Conference and Exposition (OFC/NFOEC), 2011 and the National Fiber Optic Engineers Conference*, 2011, pp. 1-3.
- [78] "Optoquest." [Online]. Available: <http://www.optoquest.co.jp/en/>.
- [79] F. E. Doany, B. G. Lee, S. Assefa, W. M. J. Green, M. Yang, C. L. Schow, C. V. Jahnes, S. Zhang, J. Singer, V. I. Kopp, J. A. Kash, and Y. A. Vlasov, "Multichannel High-Bandwidth Coupling of Ultradense Silicon Photonic Waveguide Array to Standard-Pitch Fiber Array," *J. Light. Technol.*, vol. 29, no. 4, pp. 475-482, Feb. 2011.
- [80] P. M. Krummrich, "Spatial multiplexing for high capacity transport," *Opt. Fiber Technol.*, vol. 17, no. 5, pp. 480-489, Oct. 2011.
- [81] S. Chandrasekhar, A. H. Gnauck, X. Liu, P. J. Winzer, Y. Pan, E. C. Burrows, T. F. Taunay, B. Zhu, M. Fishteyn, M. F. Yan, J. M. Fini, E. M. Monberg, and F. V. Dimarcello, "WDM/SDM transmission of 10 x 128-Gb/s PDM-QPSK over 2688-km 7-core fiber with a per-fiber net aggregate spectral-efficiency distance product of 40,320 km-kb/s/Hz," *Opt. Express*, vol. 20, no. 2, pp. 706-711, Jan. 2012.
- [82] "Chiral Photonics." [Online]. Available: <http://www.chiralphotonics.com/>.
- [83] R. R. Thomson, H. T. Bookey, N. D. Psaila, A. Fender, S. Campbell, W. N. Macpherson, J. S. Barton, D. T. Reid, and A. K. Kar, "Ultrafast-laser inscription of a three dimensional fan-out device for multicore fiber coupling applications," *Opt. Express*, vol. 15, no. 18, pp. 11691-11697, 2007.
- [84] R. Thomson, R. Harris, T. Birks, G. Brown, J. Allington-Smith, and J. Bland-Hawthorn, "Ultrafast laser inscription of a 121-waveguide fan-out for astrophotonics," *ArXiv Prepr. ArXiv12034584*, 2012.
- [85] P. Mitchell, G. Brown, R. R. Thomson, N. Psaila, and A. Kar, "57 Channel (19x3) Spatial Multiplexer Fabricated using Direct Laser Inscription," in *Optical Fiber Communication Conference*, 2014, p. M3K-5.
- [86] "Optoscribe." [Online]. Available: <http://optoscribe.com/>.
- [87] J. D. Love and N. Riesen, "Mode-selective couplers for few-mode optical fiber networks," *Opt. Lett.*, vol. 37, no. 19, pp. 3990-3992, 2012.
- [88] R. Ryf, S. Randel, A. H. Gnauck, C. Bolle, A. Sierra, S. Mumtaz, M. Esmaelpour, E. C. Burrows, R. Essiambre, P. J. Winzer, and others, "Mode-Division Multiplexing Over 96 km of Few-Mode Fiber Using Coherent 6x6 MIMO," *Light. Technol. J. Of*, vol. 30, no. 4, pp. 521-531, 2012.
- [89] R. R. Thomson, T. A. Birks, S. G. Leon-Saval, A. K. Kar, and J. B. Bland-Hawthorn, "Ultrafast laser inscription of an integrated multimode-to-single-modes waveguide transition for astrophotonics," in *Lasers and Electro-Optics Europe (CLEO EUROPE/EQEC), 2011 Conference on and 12th European Quantum Electronics Conference*, 2011, pp. 1-1.
- [90] R. Ryf, N. K. Fontaine, M. A. Mestre, S. Randel, X. Palou, C. Bolle, A. H. Gnauck, S. Chandrasekhar, X. Liu, B. Guan, and others, "12 x 12 MIMO transmission over 130-km few-mode fiber," in *Frontiers in Optics*, 2012, p. FW6C-4.
- [91] R. Ryf, N. K. Fontaine, and R. Essiambre, "Spot-based mode coupler for mode-multiplexed transmission in few-mode

- fiber,” in *2012 IEEE Photonics Society Summer Topical Meeting Series*, 2012, pp. 199–200.
- [92] A. M. J. Koonen, Haoshuo Chen, H. P. A. van den Boom, and O. Raz, “Silicon Photonic Integrated Mode Multiplexer and Demultiplexer,” *IEEE Photonics Technol. Lett.*, vol. 24, no. 21, pp. 1961–1964, Nov. 2012.
- [93] R. Nagase, “How to connect multicore and multimode fibers,” in *Optical Fiber Communication Conference*, 2014, p. Tu3D–2.
- [94] K. Sakaime, R. Nagase, K. Watanabe, and T. Saito, “Connection characteristics of MU-type multicore fiber connector,” in *Photonics Society Summer Topical Meeting Series, 2013 IEEE*, 2013, pp. 76–77.
- [95] Fujitsu Laboratories Ltd, “Fujitsu to Exhibit World’s First 100Gps Multi-Mode QSFP28 Active Optical Cable.” [Online]. Available: http://www.fujitsu.com/us/news/pr/fcai_20140304-01.html.
- [96] P. Westbrook, K. Abedin, T. Taunay, T. Kremp, J. Porque, E. Monberg, and M. Fishteyn, “Multicore fiber distributed feedback lasers,” *Opt. Lett.*, vol. 37, no. 19, pp. 4014–4016, 2012.
- [97] C. Doerr and T. Taunay, “Silicon photonics core-, wavelength-, and polarization-diversity receiver,” *Photonics Technol. Lett. IEEE*, vol. 23, no. 9, pp. 597–599, 2011.
- [98] F. E. Doany, C. L. Schow, C. K. Tsang, N. Ruiz, R. Horton, D. M. Kuchta, G. S. Patel, J. U. Knickerbocker, and J. A. Kash, “300-Gb/s 24-channel bidirectional Si carrier transceiver optochip for board-level interconnects,” in *Electronic Components and Technology Conference, 2008. ECTC 2008. 58th*, 2008, pp. 238–243.
- [99] B. Lee, D. Kuchta, F. Doany, C. Schow, C. Baks, R. John, P. Pepeljugoski, T. Taunay, B. Zhu, M. Yan, and others, “Multimode transceiver for interfacing to multicore graded-index fiber capable of carrying 120-Gb/s over 100-m lengths,” in *IEEE Photonics Society, 2010 23rd Annual Meeting of the*, 2010, pp. 564–565.
- [100] B. G. Lee, D. M. Kuchta, F. E. Doany, C. L. Schow, P. Pepeljugoski, C. Baks, T. F. Taunay, B. Zhu, M. F. Yan, G. E. Oulundsen, and others, “End-to-end multicore multimode fiber optic link operating up to 120 Gb/s,” *J. Light. Technol.*, vol. 30, no. 6, pp. 886–892, 2012.
- [101] F. E. Doany, B. G. Lee, D. M. Kuchta, A. V. Rylyakov, C. Baks, C. Jahnes, F. Libsch, and C. L. Schow, “Terabit/Sec VCSEL-Based 48-Channel Optical Module Based on Holey CMOS Transceiver IC,” *J. Light. Technol.*, vol. 31, no. 4, pp. 672–680, Feb. 2013.
- [102] M. Smit, X. Leijtens, H. Ambrosius, E. Bente, J. van der Tol, B. Smalbrugge, T. de Vries, E.-J. Geluk, J. Bolk, R. van Veldhoven, L. Augustin, P. Thijs, D. D’Agostino, H. Rabbani, K. Lawniczuk, S. Stopinski, S. Tahvili, A. Corradi, E. Kleijn, D. Dzirbrou, M. Felicetti, E. Bitincka, V. Moskalenko, J. Zhao, R. Santos, G. Gilardi, W. Yao, K. Williams, P. Stabile, P. Kuindersma, J. Pello, S. Bhat, Y. Jiao, D. Heiss, G. Roelkens, M. Wale, P. Firth, F. Soares, N. Grote, M. Schell, H. Debregeas, M. Achouche, J.-L. Gentner, A. Bakker, T. Korthorst, D. Gallagher, A. Dabbs, A. Melloni, F. Morichetti, D. Melati, A. Wonfor, R. Penty, R. Broeke, B. Musk, and D. Robbins, “An introduction to InP-based generic integration technology,” *Semicond. Sci. Technol.*, vol. 29, no. 8, p. 083001, Jun. 2014.
- [103] F. A. Kish, D. Welch, R. Nagarajan, J. L. Pleumeekers, V. Lal, M. Ziari, A. Nilsson, M. Kato, S. Murthy, P. Evans, S. W. Corzine, M. Mitchell, P. Samra, M. Missey, S. DeMars, R. P. Schneider, M. S. Reffle, T. Butrie, J. T. Rahn, M. Van Leeuwen, J. W. Stewart, D. J. H. Lambert, R. C. Muthiah, H.-S. Tsai, J. S. Bostak, A. Dentai, K.-T. Wu, H. Sun, D. J. Pavinski, J. Zhang, J. Tang, J. McNicol, M. Kuntz, V. Dominic, B. D. Taylor, R. A. Salvatore, M. Fisher, A. Spannagel, E. Strzelecka, P. Studenkov, M. Raburn, W. Williams, D. Christini, K. K. Thomson, S. S. Agashe, R. Malendevich, G. Goldfarb, S. Melle, C. Joyner, M. Kaufman, and S. G. Grubb, “Current Status of Large-Scale InP Photonic Integrated Circuits,” *IEEE J. Sel. Top. Quantum Electron.*, vol. 17, no. 6, pp. 1470–1489, Nov. 2011.
- [104] M. J. R. Heck, J. F. Bauters, M. L. Davenport, J. K. Doylend, S. Jain, G. Kurczveil, S. Srinivasan, Y. Tang, and J. E. Bowers, “Hybrid Silicon Photonic Integrated Circuit Technology,” *IEEE J. Sel. Top. Quantum Electron.*, vol. 19, no. 4, pp. 6100117–6100117, Jul. 2013.
- [105] T. Tsuchizawa, K. Yamada, T. Watanabe, S. Park, H. Nishi, R. Kou, H. Shinojima, and S. Itabashi, “Monolithic Integration of Silicon-, Germanium-, and Silica-Based Optical Devices for Telecommunications Applications,” *IEEE J. Sel. Top. Quantum Electron.*, vol. 17, no. 3, pp. 516–525, May 2011.
- [106] A. Li, A. Al Amin, X. Chen, and W. Shieh, “Reception of mode and polarization multiplexed 107-Gb/s CO-OFDM signal over a two-mode fiber,” in *Optical Fiber Communication Conference and Exposition (OFC/NFOEC), 2011 and the National Fiber Optic Engineers Conference*, 2011, pp. 1–3.
- [107] R. Ryf, S. Randel, A. H. Gnauck, C. Bolle, R. Essiambre, P. J. Winzer, D. W. Peckham, A. McCurdy, and R. Lingle, “Space-division multiplexing over 10 km of three-mode fiber using coherent 6 x 6 MIMO processing,” in *Optical Fiber Communication Conference and Exposition (OFC/NFOEC), 2011 and the National Fiber Optic Engineers Conference*, 2011, pp. 1–3.
- [108] J. Carpenter and T. D. Wilkinson, “All Optical Mode-Multiplexing Using Holography and Multimode Fiber Couplers,” *J. Light. Technol.*, vol. 30, no. 12, pp. 1978–1984, Jun. 2012.
- [109] Y. Ding, H. Ou, J. Xu, and C. Peucheret, “Silicon Photonic Integrated Circuit Mode Multiplexer,” *IEEE Photonics Technol. Lett.*, vol. 25, no. 7, pp. 648–651, Apr. 2013.
- [110] C. R. Doerr and T. F. Taunay, “Silicon Photonics Core-, Wavelength-, and Polarization-Diversity Receiver,” *IEEE Photonics Technol. Lett.*, vol. 23, no. 9, pp. 597–599, May 2011.
- [111] N. K. Fontaine, C. R. Doerr, M. A. Mestre, R. Ryf, P. Winzer, L. Buhl, Y. Sun, X. Jiang, R. Lingle, and others, “Space-division multiplexing and all-optical MIMO demultiplexing using a photonic integrated circuit,” in *Optical Fiber Communication Conference*, 2012, p. PDP5B–1.
- [112] D. Kuchta, A. Rylyakov, C. Schow, J. Proesel, F. Doany, C. W. Baks, B. Hamel-Bissell, C. Kocot, L. Graham, R. Johnson, and others, “A 56.1 Gb/s NRZ modulated 850nm VCSEL-based optical link,” in *Optical Fiber Communication Conference*, 2013, p. OW1B–5.
- [113] N. Dupuis, D. Kuchta, F. E. Doany, A. V. Rylyakov, J. Proesel, C. Baks, C. L. Schow, S. Luong, C. Xie, L. Wang, and others, “Exploring the limits of high-speed receivers for multimode VCSEL-based optical links,” in *Optical Fiber Communication Conference*, 2014, p. M3G–5.
- [114] N. Amaya, S. Yan, M. Channegowda, B. R. Rofoe, Y. Shu, M. Rashidi, Y. Ou, G. Zervas, R. Nejabati, D. Simeonidou, and others, “First demonstration of software defined networking (SDN) over space division multiplexing (SDM) optical networks,” in *Proceedings of the 39th European Conference and Exhibition on Optical Communication (ECOC 2013), London, UK*, 2013, pp. 22–26.
- [115] L. E. Nelson, M. D. Feuer, K. Abedin, X. Zhou, T. F. Taunay, J. M. Fini, B. Zhu, R. Isaac, R. Harel, G. Cohen, and D. M. Marom, “Spatial Superchannel Routing in a Two-Span ROADM System for Space Division Multiplexing,” *J. Light. Technol.*, vol. 32, no. 4, pp. 783–789, Feb. 2014.
- [116] D. Klonidis, F. Cugini, O. Gerstel, M. Jinno, V. Lopez, E. Palkopoulou, M. Sekiya, D. Siracusa, G. Thouenon, and C. Betoule, “Spectrally and spatially flexible optical network planning and operations,” *IEEE Commun. Mag.*, vol. 53, no. 2, pp. 69–78, Feb. 2015.
- [117] D. M. Marom and M. Blau, “Switching solutions for WDM-SDM optical networks,” *IEEE Commun. Mag.*, vol. 53, no. 2, pp. 60–68, Feb. 2015.

- [118] T. J. Xia, H. Fevrier, T. Wang, and T. Morioka, "Introduction of spectrally and spatially flexible optical networks," *Commun. Mag. IEEE*, vol. 53, no. 2, pp. 24–33, 2015.
- [119] A. Muhammad, G. Zervas, G. M. Saridis, E. Hugues-Salas, D. Simeonidou, and R. Forchheimer, "Flexible and Synthetic SDM Networks with Multi-core-Fibers Implemented by Programmable ROADMs," in *ECOC*, 2014, vol. P 6.6.
- [120] J. Sakaguchi, W. Klaus, B. J. Puttnam, T. Miyazawa, Y. Awaji, J. M. Delgado Mendinueta, R. S. Luis, and N. Wada, "SDM-WDM hybrid reconfigurable add-drop nodes for self-homodyne photonic networks," in *Photonics Society Summer Topical Meeting Series, 2013 IEEE*, 2013, pp. 117–118.
- [121] J. Carpenter, S. G. Leon-Saval, J. R. Salazar Gil, J. Bland-Hawthorn, G. Baxter, L. Stewart, S. Frisken, M. A. F. Roelens, B. J. Eggleton, and J. Schroder, "1 x 11 few-mode fiber wavelength selective switch using photonic lanterns," in *Optical Fiber Communications Conference and Exhibition (OFC), 2014*, 2014, pp. 1–3.
- [122] A. Muhammad, G. Zervas, N. Amaya, D. Simeonidou, and R. Forchheimer, "Introducing Flexible and Synthetic Optical Networking: Planning and Operation Based on Network Function Programmable ROADMs," *J. Opt. Commun. Netw.*, vol. 6, no. 7, pp. 635–648, 2014.
- [123] T. Miyazaki and F. Kubota, "PSK self-homodyne detection using a pilot carrier for multibit/symbol transmission with inverse-RZ signal," *IEEE Photonics Technol. Lett.*, vol. 17, no. 6, pp. 1334–1336, Jun. 2005.
- [124] R. Luis, B. J. Puttnam, J. Mendinueta, J. Sakaguchi, W. Klaus, Y. Awaji, N. Wada, A. Kanno, and T. Kawanishi, "In-service method of path length alignment in SDM systems with self-homodyne detection," in *OptoElectronics and Communications Conference held jointly with 2013 International Conference on Photonics in Switching (OECC/PS), 2013 18th*, 2013, pp. 1–2.
- [125] R. S. Luis, B. J. Puttnam, J. M. D. Mendinueta, W. Klaus, J. Sakaguchi, Y. Awaji, T. Kawanishi, A. Kanno, and N. Wada, "OSNR Penalty of Self-Homodyne Coherent Detection in Spatial-Division-Multiplexing Systems," *IEEE Photonics Technol. Lett.*, vol. 26, no. 5, pp. 477–479, Mar. 2014.
- [126] B. J. Puttnam, J. Sakaguchi, W. Klaus, Y. Awaji, J. M. Delgado Mendinueta, N. Wada, A. Kanno, and T. Kawanishi, "Investigating self-homodyne coherent detection in a 19-core spatial-division-multiplexed transmission link," in *European Conference and Exhibition on Optical Communication*, 2012, p. Tu–3.
- [127] M. Cvijetic, I. B. Djordjevic, and N. Cvijetic, "Dynamic multidimensional optical networking based on spatial and spectral processing," *Opt. Express*, vol. 20, no. 8, pp. 9144–9150, 2012.
- [128] N. Amaya, M. Irfan, G. Zervas, R. Nejabati, D. Simeonidou, J. Sakaguchi, W. Klaus, B. J. Puttnam, T. Miyazawa, Y. Awaji, N. Wada, and I. Henning, "Fully-elastic multi-granular network with space/frequency/time switching using multi-core fibres and programmable optical nodes," *Opt. Express*, vol. 21, no. 7, p. 8865, Apr. 2013.
- [129] R. Proietti, L. Liu, R. P. Scott, B. Guan, C. Qin, T. Su, F. Giannone, and S. J. B. Yoo, "3D elastic optical networking in the temporal, spectral, and spatial domains," *IEEE Commun. Mag.*, vol. 53, no. 2, pp. 79–87, Feb. 2015.
- [130] N. Amaya, S. Yan, M. Channegowda, B. R. Rofoee, Y. Shu, M. Rashidi, Y. Ou, E. Hugues-Salas, G. Zervas, R. Nejabati, D. Simeonidou, B. J. Puttnam, W. Klaus, J. Sakaguchi, T. Miyazawa, Y. Awaji, H. Harai, and N. Wada, "Software defined networking (SDN) over space division multiplexing (SDM) optical networks: features, benefits and experimental demonstration," *Opt. Express*, vol. 22, no. 3, pp. 3638–3647, Feb. 2014.
- [131] N. Amaya, M. Irfan, G. S. Zervas, R. Nejabati, D. Simeonidou, V. Rancano, F. Parmigiani, P. Petropoulos, D. J. Richardson, J. Sakaguchi, and others, "On-Demand Spectrum and Space Defragmentation in an Elastic SDM/FDM/TDM Network with Mixed Multi-and Single-core Fiber Links," in *Optical Fiber Communication Conference*, 2013, p. OTh4B–3.
- [132] S. Fujii, Y. Hirota, H. Tode, and K. Murakami, "On-Demand Spectrum and Core Allocation for Multi-Core Fibers in Elastic Optical Network," in *Optical Fiber Communication Conference*, 2013.
- [133] A. Muhammad, G. Zervas, D. Simeonidou, and R. Forchheimer, "Routing, spectrum and core allocation in flexgrid SDM networks with multi-core fibers," in *2014 International Conference on Optical Network Design and Modeling*, 2014, pp. 192–197.
- [134] Y. Zhang, L. Yan, H. Wang, and W. Gu, "Routing, Wavelength and Mode Assignment Algorithm for Space Division Multiplexing Transmission Network," in *Instrumentation, Measurement, Computer, Communication and Control (IMCCC), 2012 Second International Conference on*, 2012, pp. 1383–1385.
- [135] S. Fujii, Y. Hirota, T. Watanabe, and H. Tode, "Dynamic spectrum and core allocation with spectrum region reducing costs of building modules in AoD nodes," in *Telecommunications Network Strategy and Planning Symposium (Networks), 2014 16th International*, 2014, pp. 1–6.
- [136] H. Tode and Y. Hirota, "Routing, spectrum and core assignment for space division multiplexing elastic optical networks," in *Telecommunications Network Strategy and Planning Symposium (Networks), 2014 16th International*, 2014, pp. 1–7.
- [137] P. Winzer, A. Gnauck, A. Konczykowska, F. Jorge, and J.-Y. Dupuy, "Penalties from in-band crosstalk for advanced optical modulation formats," in *European Conference and Exposition on Optical Communications*, 2011.
- [138] T. Hayashi, T. Taru, O. Shimakawa, T. Sasaki, and E. Sasaoka, "Uncoupled multi-core fiber enhancing signal-to-noise ratio," *Opt. Express*, vol. 20, no. 26, pp. B94–B103, 2012.
- [139] T. Hayashi, T. Taru, O. Shimakawa, T. Sasaki, and E. Sasaoka, "Characterization of crosstalk in ultra-low-crosstalk multi-core fiber," *Light. Technol. J. Of*, vol. 30, no. 4, pp. 583–589, 2012.
- [140] M. Koshiba, K. Saitoh, K. Takenaga, and S. Matsuo, "Analytical Expression of Average Power-Coupling Coefficients for Estimating Intercore Crosstalk in Multicore Fibers," *IEEE Photonics J.*, vol. 4, no. 5, pp. 1987–1995, Oct. 2012.
- [141] K. Saitoh, M. Koshiba, K. Takenaga, and S. Matsuo, "Crosstalk and Core Density in Uncoupled Multicore Fibers," *IEEE Photonics Technol. Lett.*, vol. 24, no. 21, pp. 1898–1901, Nov. 2012.
- [142] A. A. Stavdas, *Core and metro networks*. Chichester, U.K.: Wiley, 2010.
- [143] A. Vahdat, H. Liu, X. Zhao, and C. Johnson, "The emerging optical data center," in *Optical Fiber Communication Conference and Exposition (OFC/NFOEC), 2011 and the National Fiber Optic Engineers Conference*, 2011, pp. 1–3.
- [144] "Microsoft Datacenters." [Online]. Available: <http://www.microsoft.com/datacenters>.
- [145] "Google Data Centers." [Online]. Available: <http://www.google.com/about/datacenters/>.
- [146] R. Hays and H. Frasier, "40G Ethernet market potential," in *IEEE 802.3 HSSG Interim Meeting, April, 2007*, vol. 1.
- [147] S. Yan, E. Hugues-Salas, V. J. F. Rancano, Y. Shu, G. Saridis, B. Rahimzadeh Rofoee, Y. Yan, A. Peters, S. Jain, T. May-Smith, P. Petropoulos, D. J. Richardson, G. Zervas, and D. Simeonidou, "Archon: A Function Programmable Optical Interconnect Architecture for Transparent Intra and Inter Data Center SDM/TDM/WDM Networking," *J. Light. Technol.*, pp. 1–1, 2015.
- [148] P. J. Winzer, "Energy-efficient optical transport capacity scaling through spatial multiplexing," *Photonics Technol. Lett. IEEE*, vol. 23, no. 13, pp. 851–853, 2011.

- [149] K.-P. Ho and J. M. Kahn, "Linear Propagation Effects in Mode-Division Multiplexing Systems," *J. Light. Technol.*, vol. 32, no. 4, pp. 614–628, Feb. 2014.
- [150] A. Lobato, F. Ferreira, J. Rabe, B. Inan, S. Adhikari, M. Kuschnerov, A. Napoli, B. Spinnler, and B. Lankl, "On the mode-dependent loss compensation for mode-division multiplexed systems," in *2013 15th International Conference on Transparent Optical Networks (ICTON)*, 2013, pp. 1–4.
- [151] C. M. Serpa-Imbett, J. Marin-Alfonso, C. Gomez-Santamaria, L. Betancur, and F. Amaya-Fernandez, "Performance of spatially multiplexed systems based on numerical simulations of OFDM-MIMO in a two-core fiber with low coupling, and a few mode fiber with high DGD," in *Microwave Optoelectronics Conference (IMOC), 2013 SBMO/IEEE MTT-S International*, 2013, pp. 1–4.
- [152] N. J. A. Sloane, *The encyclopedia of integer sequences*. 1995.



George M. Saridis was born in Thessaloniki, Greece, in 1990. He received his Bachelor's degree from Computer Science Department, Aristotle University of Thessaloniki, where he also worked closely with photonics and optical switching for his graduation thesis. He is currently studying towards his PhD degree and is a member of the High Performance Networks group at University of Bristol, U.K. His research is

mainly focused on optical data plane architectures for flexible, low-latency, scalable & energy-efficient next generation optical intra Data-Centre Networks & High Performance Computing interconnects. Among his main interests is also space division multiplexing (SDM) in conjunction with other novel technologies for future all-optical networks. His work has been accepted for oral presentation in international optical communication conferences like OFC 2015 and ECOC 2015. George is also involved and has contributed in prominent EU and UK funded research projects.

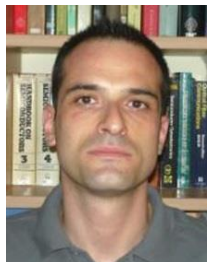

Dimitris Alexandropoulos received the B.Sc degree in physics in 1998 from the University Athens, Athens, Greece, and the M.Sc. degree in the physics of laser communications in 1999 from the University of Essex, Colchester, Essex, U.K., and the PhD degree for work on GaInNAs-based optoelectronic devices, from the same University in 2003. After one year of postdoctoral work at the University of Essex he moved in 2004 to the Optical

Communications Laboratory, Department of Informatics and Telecommunications, University of Athens. He is now a Lecturer in nanophotonics at the Department of Materials Science, University of Patras, Patras, Greece. He is also a visiting fellow of the School of Computer Science and Electronic Engineering, University of Essex, Colchester, Essex, U.K. He has co-authored more than 50 journal and conference publications. His research interests include novel photonic materials, photonic sensors, optical communications, integrated photonics and optoelectronic devices.



Georgios Zervas received the M.Eng. and Ph.D. degrees from the University of Essex. He was a Research Fellow and a Lecturer at Essex until 2012. He is currently a Senior Lecturer of Optical and High Performance Networks, and member of the HPN group at University of Bristol. He is leading the research activities in optical transport and switching, as well as

software/hardware programmable on-chip and off-chip systems for data-center/high performance computing and telecom networks. He is TPC sub-committee chair at OFC 2016 and has been serving as TPC member of leading international conferences including OFC,

ICC, ACP, OECC, PS, ONDM, GLOBECOM among others and contributor to standards. He has given numerous invited talks at international conferences, symposia, workshops and standardization fora. Dr. Zervas has organised and chaired high profile workshops at OFC 2013 and ECOC 2013 that signified the launch of space division multiplexed optical networking research. Over the last 10 years, Georgios has participated in numerous EU and UK funded research projects with the roles of principal/co investigator, work package leader and research investigator. He has published over 160 international journal and conference papers including nine post deadline OFC/ECOC papers and has received best paper awards.



Dimitra Simeonidou is Professor of High Performance Networks group at University of Bristol. Dimitra is a leading academic in Optical Networks, Future Internet Research and Experimentation (FIRE), Grid and Cloud Computing, and a founder of Transport Software Defined Networking. She has chaired a number of international conferences and committees across these technical fields. She is the author and co-author of over 400 publications of which

many have received best paper awards, 11 patents and standards.