

2-1-1991

Survey of robust control for rigid robots

Chaouki T. Abdallah

D. Dawson

Peter Dorato

M. Jamshidi

Follow this and additional works at: http://digitalrepository.unm.edu/ece_fsp

Recommended Citation

Abdallah, Chaouki T.; D. Dawson; Peter Dorato; and M. Jamshidi. "Survey of robust control for rigid robots." *Control Systems Magazine* 11, 2 (1991): 24-30. doi:10.1109/37.67672.

This Article is brought to you for free and open access by the Engineering Publications at UNM Digital Repository. It has been accepted for inclusion in Electrical & Computer Engineering Faculty Publications by an authorized administrator of UNM Digital Repository. For more information, please contact disc@unm.edu.

Survey of Robust Control for Rigid Robots

C. Abdallah, D. Dawson, P. Dorato, and M. Jamshidi

This survey discusses current approaches to the robust control of the motion of rigid robots and summarizes the available literature on the subject. The five major designs discussed are the "Linear-Multivariable" approach, the "Passivity" approach, the "Variable-Structure" approach, the "Saturation" approach and the "Robust-Adaptive" approach.

Introduction

There are basically two underlying philosophies to the control of uncertain systems: the adaptive control philosophy, and the robust control philosophy. In the adaptive approach, one designs a controller which attempts to "learn" the uncertain parameters of the particular system and, if properly designed will eventually be a "best" controller for the system in question. In the robust approach, the controller has a fixed-structure which yields "acceptable" performance for a given plant-uncertainty set. In general, the adaptive approach is applicable to a wider range of uncertainties, but robust controllers are simpler to implement and no time is required to "tune" the controller to the plant variations. More recently, researchers have attempted to "robustify" certain adaptive controllers in order to combine the advantages of both approaches.

We review here different robust control designs used in controlling the motion of robots. A discussion of adaptive controllers in robotics may be found in [1]. A comprehensive survey of robust control theory is available in [3],[18]. The techniques discussed in this survey belong to one of five categories. The first is the linear-multivariable or feedback-linearization approach [2] where the in-

verse dynamics of the robot are used in order to globally linearize and decouple the robot's equations. Since one does not have access to the exact inverse dynamics, the linearization and the decoupling will not be exact. This will be manifested by uncertain feedback terms that may be handled using multivariable linear robust control techniques [3]. The methods based on computed-torque such as those of [4]-[11] fall under this heading.

The second category contains methods that exploit the passive nature of the robot [12]. These techniques try to maintain the passivity of the closed-loop robot/controller system despite uncertain knowledge of the robot's parameters. Although not as transparent to linear control techniques as the computed-torque approach is, passivity-based methods can nonetheless guarantee the robust stability of the closed-loop robot/controller system. The works described in [13],[14],[40] fall under this category and will be discussed in this paper.

Next, we group methods that are for the most part Lyapunov-based nonlinear control schemes. These include variable-structure and saturation controllers which attempt to robustly control a rigid robot. Some of these techniques may actually rely on the feedback-linearizability or the passivity of the robot dynamics and may have been included in those approaches.

Finally, we briefly survey approaches that combine robust and adaptive techniques. It should be noted that other classifications of robust controllers in robotics are possible and that this survey reflects our own philosophy rather than a universally accepted division.

Let the rigid robot dynamics be given in joint-space by the Lagrange-Euler equations [19] where q is an n vector of generalized coordinates representing the joints positions, and τ is the generalized n torque input vector. The matrix $D(q)$ is an $n \times n$ symmetric positive-definite inertia matrix and $h(q,\dot{q})$ is an n vector containing the Coriolis, centrifugal, and gravity terms.

$$D(q)\ddot{q} + h(q,\dot{q}) = \tau. \quad (1)$$

In general, (1) arises as a solution to the Lagrange equations of motion for natural systems [20]. In this paper, we survey methods

which deal primarily with designing controllers that will make q and \dot{q} track some desired q_d and \dot{q}_d when some entries of $D(q)$ and $h(q,\dot{q})$ are uncertain. This survey is by no means exhaustive and will also exclude the important case when the robot comes in contact with the environment.

Linear-Multivariable Approach

In this section we review different designs which use linear multivariable techniques to obtain robust robot controllers. In the early days of robot control, the idea of linearizing the nonlinear robot dynamics about their desired trajectory (using a Taylor series expansion for example) was popular, and many controllers were designed that way [21],[23],[42],[43]. Later however, the physics and special structure of equation (1), coupled with the fact that the control τ provides an independent input for each degree of freedom [2],[12], led to the "global" linearization of the nonlinear robotic system. It is this later approach that is stressed in this section. For an excellent description of the exact linearization of robots see [2]. By defining the trajectory error vector, $e_1 = q - q_d$, $e_2 = \dot{e}_1$, one is able to globally linearize the nonlinear error system, to the following:

$$\begin{aligned} \dot{e} &= A e + B v \\ A &= \begin{bmatrix} 0 & I \\ 0 & 0 \end{bmatrix} \\ B &= \begin{bmatrix} 0 \\ I \end{bmatrix} \\ e &= \begin{bmatrix} e_1 \\ e_2 \end{bmatrix} \\ v &= D(q)^{-1} [\tau - h(q,\dot{q}) - \ddot{q}_d] \end{aligned} \quad (2)$$

The problem is then reduced to finding a linear control v which will achieve a desired closed-loop performance, i.e. find F, G, H and J in

$$\begin{aligned} \dot{z} &= F z + G e, \\ v &= H z + J e, \end{aligned}$$

or

Presented at the 1990 American Control Conference, San Diego, CA, May 23-25, 1990. C. Abdallah, P. Dorato, and M. Jamshidi are with the CAD Laboratory for Systems and Robotics, Electrical and Computer Engineering Department, University of New Mexico, Albuquerque, NM 87131. D. Dawson is with the Department of Electrical and Computer Engineering, Clemson University, Clemson, SC 29634-0915.

$$v(t) = [(sI - F)^{-1}G + J] e(t) \quad (3)$$

$$\equiv C(s) e(t)$$

Note that the above notation indicates that $v(t)$ is the output of a system $C(s)$ when an input $e(t)$ is applied. The following static state-feedback controller is often used:

$$\begin{aligned} F &= G = H = 0, \\ J &= -K \\ v &= -K_1 e_1 - K_2 e_2 \equiv -K e \end{aligned} \quad (4)$$

leading to the nonlinear controller

$$\tau = D(q) [\ddot{q}_d + v] + h(q, \dot{q}) \quad (5)$$

which, due to the invertibility of $D(q)$ gives the following closed-loop system:

$$\ddot{e}_1 + K_2 \dot{e}_1 + K_1 e_1 = 0. \quad (6)$$

Unfortunately, the control law (5) can not usually be implemented due to its complexity or to uncertainties present in $D(q)$ and $h(q, \dot{q})$. Instead, one applies τ in (7) where \hat{D} and \hat{h} are estimates of D and h :

$$\tau = \hat{D} [\ddot{q}_d + v] + \hat{h}. \quad (7)$$

This in turn leads to (Fig. 1):

$$\begin{aligned} \dot{e} &= A e + B (v + \eta) \\ \eta &= E (v + \ddot{q}_d) + D^{-1} \Delta h \\ E &= D^{-1} \hat{D} - I_n, \\ \Delta h &= \hat{h} - h. \end{aligned} \quad (8)$$

The vector η is a nonlinear function of both e and v and can not be treated as an external disturbance. It represents a disturbance of the globally linearized error dynamics which is caused by modeling uncertainties, parameter variations, external disturbances and maybe even noisy measurements [4]. The linear multivariable approaches then revolve around the design of linear controllers $C(s)$ (which may be dynamical), such that the complete closed-loop system (Fig. 1) is stable in some suitable sense, e.g. uniformly ultimately bounded [38], globally asymptotically stable, etc. for a given class of nonlinear perturbation η . In other words, choose $C(s)$ in (3) such that the error $e(t)$ in (9) is stable,

$$\dot{e} = A e + B (v + \eta) \quad (9)$$

$$v(t) = C(s) e(t). \quad (10)$$

The reasonable assumptions (11)-(13) below are often made for revolute-joint robots when

using this approach [24]. In the following, d_1 , d_2 , α , β_0 , β_1 , and β_2 are nonnegative finite constants which depend on the size of the uncertainties:

$$(d_2)^{-1} I_n \leq \|D^{-1}\| \leq (d_1)^{-1} I_n \quad (11)$$

$$\|E\| \leq \alpha \quad (12)$$

$$\|\Delta h\| \leq \beta_0 + \beta_1 \|e\| + \beta_2 \|e\|^2 \quad (13)$$

Note that assumption (13) must be modified for robots with prismatic joints.

In general, the small-gain theorem [25], the passivity theorem [25], or the total stability theorem [26] are invoked to find $C(s)$. The most general of these controllers have been designed using Youla parametrization and H^∞ control theory [27],[28] and will be discussed first.

Spong and Vidyasagar [4] used the factorization approach [27] to design a class of linear compensators $C(s)$, parametrized by a stable transfer matrix $R(s)$, which guarantee

Static feedback compensators such as the ones given in (4) have also been used extensively starting with the works of Freund [30], and Tarn *et al.* [6], where

$$v = C(s) e = -K e \quad (14)$$

such that

$$\begin{aligned} \dot{e} &= A e + B (v + \eta) \\ &= (A - B K) e + B \eta = A_c e + B \eta. \end{aligned} \quad (15)$$

In these papers, the authors use state feedback to either place the poles sufficiently far in the left-half-plane [9], therefore guaranteeing stability in the presence of η (by the total stability theorem for example), or an extra control loop [6] to correct for the effects of η . In [40], the state-feedback controller was used to define an appropriate output Ke such that the input-output closed-loop linear systems $K(sI - A + BK)^{-1}B$ is Strictly-Positive-Real (SPR). The closed-loop stability was then assured for all η resulting from a passive non-

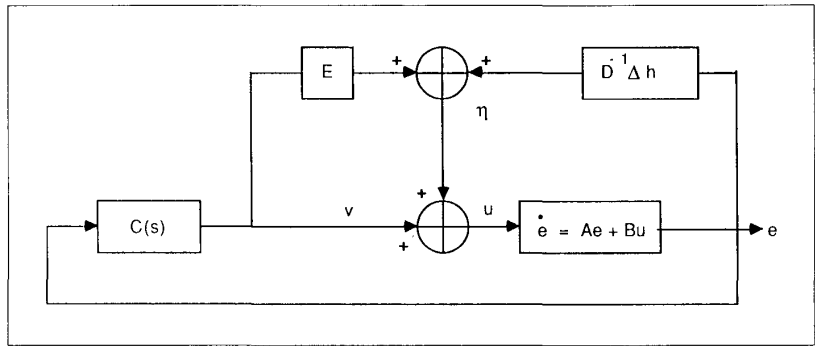

Fig. 1. Linear multivariable design.

that the solution $e(t)$ to the linear system (8) has a bounded L_∞ norm. The authors actually assumed that the bound on Δh is linear, i.e. $\beta_2=0$ in (13) and found the family of all L_∞ stabilizing compensators of the nominal plant. A particular compensator may then be obtained by choosing the parameter $R(s)$ to satisfy other design criteria such as suppressing the effects of η . As was discussed in [24], including the more reasonable quadratic bound will not destroy the L_∞ stability result, but will exclude any L_2 results unless the problem is reformulated and more assumptions are made. In particular, noisy measurements are no longer tolerated. Craig [29] discussed the L_2 problem in a similar setting, and under certain conditions, was able to show the boundedness of the error signals.

linear system by using the passivity theorem [25]. In Kuo and Wang [31], the internal model principle developed by Francis and Wonham [32] is used to design a linear controller which minimizes the effects of the disturbance term η . However, since η is a nonlinear function of e and v , minimizing its effects does not necessarily guarantee closed-loop stability. In Gilbert and Ha [10], Proportional-Integral-Derivative control is applied in order to obtain some sensitivity improvements. Cai and Goldenberg [33] use Proportional-Integral control to improve the robustness properties of the controller. Arimoto and Miyazaki [34] use Proportional-Integral-Derivative feedback control to robustly stabilize robot manipulators.

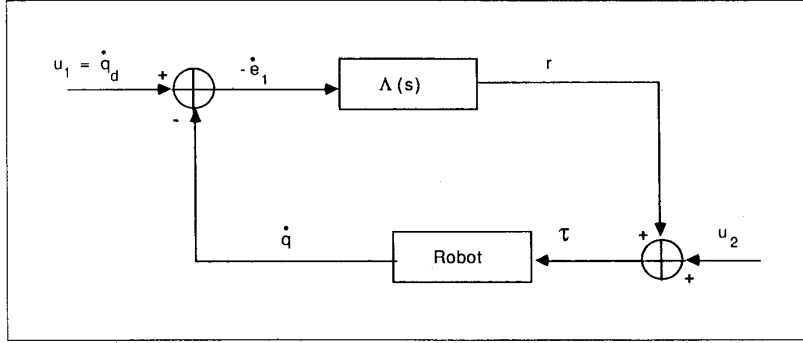

Fig. 2. Passive controller design.

The feedback-linearization approach has been popular (under different names) in the robotics field. Its main advantage is obviously the wealth of linear techniques which may be used in the linear outer loop. In the presence of contact forces however, this approach becomes much more involved as was discussed in [14]. In addition, many controllers designed using this approach are not practical because they require a large control effort.

In some cases, the previously mentioned local linearization approach was combined with other techniques in order to guarantee robust stability [21],[23],[42]. In particular, Desa and Roth [23] used the internal model principle to minimize the effects of disturbances for a robot model linearized over segments of the total operating time. Here also, closed-loop stability is not guaranteed.

Passivity-Based Approach

In this section, we review approaches which rely on the passive structure of rigid robots as described in equation (16) where $h(q, \dot{q}) = C(q, \dot{q})\dot{q} + g(q)$, and $D(q) - 2C(q, \dot{q})$ is skew-symmetric by an appropriate choice of $C(q, \dot{q})$ [12]:

$$D(q)\ddot{q} + C(q, \dot{q})\dot{q} + g(q) = \tau. \quad (16)$$

As a result of the skew-symmetry of $D - 2C$, the following theorem is obtained.

Theorem [1]: The Lagrange-Euler dynamical equations of a rigid robot (1) define a passive mapping from τ to \dot{q} , i.e. for some $\beta > 0$ and all T finite, the following inequality holds:

$$\langle \dot{q}, \tau \rangle_T \equiv \int_0^T \dot{q}^T \tau dt \geq -\beta. \quad (17)$$

Based on this theorem, if one can close the loop from \dot{q} to τ with a passive system (along with L_2 bounded inputs) as in Fig. 2, the closed-loop system will be asymptotically stable using the passivity theorem [25]. This how-

ever, will only show the asymptotic stability of \dot{e}_1 and not of e_1 . On the other hand, if one can show the passivity of the system which maps τ to a new vector r which is a filtered version of e_1 , then a controller which closes the loop between $-r$ and τ will guarantee the asymptotic stability of both e_1 and \dot{e}_1 . This indirect use of the passivity property was illustrated in [1],[55] and will be discussed next. Let the controller be given by (18)-(21) where $F(s)$ is a strictly proper, stable, rational function and K , is a positive definite matrix,

$$\tau = D(q)a + C(q, \dot{q})v + G(q) - K_r(\dot{q} - v) \quad (18)$$

$$v = \dot{q} - r \quad (19)$$

$$r = - \left[sI + \frac{K(s)}{s} \right] e_1 \quad (20)$$

$$= -F(s)^{-1}e_1 \quad (21)$$

$$a = \dot{v}.$$

Then it may be shown that both e_1 and \dot{e}_1 , are asymptotically stable. This approach was used in the adaptive control literature to design passive controllers [1] but its modification in the design of robust controllers when D , C and G are not exactly known is not obvious.

On the other hand, consider the control law (22) where $\Lambda(s)$ is an SPR transfer function,

$$\tau = -\Lambda(s)\dot{e}_1 + u_2. \quad (22)$$

The external input u_2 has to be bounded in the L_2 norm. Unfortunately, the inclusion of an integrator which reconstructs the error e_1 will destroy the SPR condition. Substituting the above control law into equation (16), one gets from Fig. 2:

$$r = -\Lambda(s)\dot{e}_1. \quad (22)$$

By an appropriate choice of $\Lambda(s)$ and u_2 , one can apply the passivity theorem and deduce that \dot{e}_1 and r are bounded in the L_2 norm, and

since $\Lambda(s)^{-1}$ is SPR (being the inverse of an SPR function), one deduces that e_1 , is asymptotically stable because

$$\dot{e}_1 = -\Lambda(s)^{-1}r. \quad (23)$$

Unfortunately, as discussed above, this will only imply that the position error e_1 is bounded but not its asymptotic stability in the case of time-varying trajectories $[q_d^T \dot{q}_d^T]^T T$. In the set-point tracking case however, and with gravity precompensation, the asymptotic stability of e_1 , may be deduced using LaSalle's theorem [19]. The robustness of the controller (22) is guaranteed as long as $\Lambda(s)$ is SPR and that u_2 is L_2 bounded, regardless of the exact values of the robot's parameters. Note that the controller (22) may be deduced from (5) by choosing the nonlinear controller

$$\begin{aligned} \tau &= D[\ddot{q} + v] + C\dot{q} + g \\ v &= -D^{-1}[\Lambda(s)\dot{e}_1 + C\dot{q} + g] \\ u_2 &= D\ddot{q}_d. \end{aligned} \quad (24)$$

The passivity approach in (22) is then a modified version of the feedback-linearization approaches. In [13],[14], however, Anderson demonstrated using network-theoretic concepts, that even in the absence of contact forces, a feedback-linearization-based controller is not passive and may therefore cause instabilities in the presence of uncertainties. His solution to the problem consisted of using Proportional-Derivative (PD) controllers with variable gains $K_1(q)$ and $K_2(q)$ which depend on the inertia matrix $D(q)$, i.e.

$$\tau = -K_1(q)e_1 - K_2(q)\dot{e}_1 + g. \quad (25)$$

Even though $D(q)$ is not exactly known, the stability of the closed-loop error is guaranteed by the passivity of the robot and the feedback law. The advantage of this approach is that contact forces and larger uncertainties may now be accommodated. Its main disadvantage is that although robust stability is guaranteed, the closed-loop performance depends on the knowledge of $D(q)$ whose singular values are needed in order to find K_1 and K_2 .

Variable-Structure Controllers

In this section, we group designs that use variable-structure controllers [15]. The VSS theory has been applied to the control of many nonlinear processes [63]. One of the main features of this approach is that one only needs to drive the error to a "switching surface," after which the system is in "sliding mode" and will not be affected by any modeling uncertainties and/or disturbances [15],[16]. The first ap-

plication of this theory to robot control seems to be in the work of Young [16] where the set point regulation problem ($\dot{q}=0$) was solved using the following controller:

$$\tau_i = \begin{cases} \tau_i^+, & \text{if } s_i(e_i, \dot{q}_i) > 0 \\ \tau_i^-, & \text{if } s_i(e_i, \dot{q}_i) < 0 \end{cases} \quad (26)$$

where $i=1, \dots, n$ for an n -link robot, and s_i are the switching planes,

$$s_i(e_i, \dot{q}_i) = c_i e_i + \dot{q}_i, \quad c_i > 0. \quad (27)$$

It is then shown using the hierarchy of the sliding surfaces s_1, s_2, \dots, s_n and given bounds on the uncertainties in the manipulators model, that one can find τ^+ and τ^- in order to drive the error signal to the intersection of the sliding surfaces after which the error will "slide" to zero. This controller eliminates the nonlinear coupling of the joints by forcing the system into the sliding mode. In [58], a modification of the Young controller was presented. Other VSS robot controllers may be found in [53],[59],[60]. Unfortunately, for most of these schemes, the control effort as seen from (26) is discontinuous along $s_i = 0$ and will therefore create "chattering" which may excite unmodeled high-frequency dynamics.

To address this problem, Slotine modified the original VSS controllers using the so-called "suction control" [17],[41]. In this approach, the sliding surface s is allowed to be time-varying and the control procedure consists of two steps. In the first, the control law forces the trajectory towards the sliding surface while in the second step, the controller is smoothed inside a possibly time-varying boundary layer. This will achieve optimal trade-off between control bandwidth and tracking precision, therefore eliminating chattering and the sensitivity of the controller to high-frequency unmodeled dynamics. The controller structure in this case is given by (28) where Λ is a diagonal matrix of positive elements λ_i (which may be time-varying) and $\phi(\cdot)$ is a nonlinear term determined by the extent of the parametric uncertainties and the suction control modifications [17],

$$\begin{aligned} \tau &= \hat{D} [\ddot{q}_d - K_2 \dot{e}_1 - K_1^2 e_1 - \phi(q, \dot{q}, t)] + \hat{h} \\ K_1 &= \Lambda^2 \\ K_2 &= 2\Lambda \end{aligned} \quad (28)$$

More recently, in [61],[62], VSS controllers which avoided the inversion of the inertia matrix were introduced. The VSS approach although theoretically appealing, does not fully exploit the physics of the robots. In addition, in practice and to avoid chattering, the asymptotic stability of the error is sacrificed.

Robust Saturation Approach

In this section, we review the research that utilizes an auxiliary saturating controller to compensate for the uncertainty present in the robot dynamics as given by (29) where $D(q)$ and $C(q, \dot{q})$ are defined in (16), and $Z(q, \dot{q})$ is an n -vector representing friction, gravity and bounded torque disturbances:

$$D(q) \ddot{q} + C(q, \dot{q}) \dot{q} + Z(q, \dot{q}) = \tau. \quad (29)$$

The controllers introduced in this section are robust due to the fact they only depend on uncertainty bounds rather than on the actual values of the parameters. The following bounds are needed and may be physically justified. The d_i 's and ζ_i 's in (30) and (31) are positive scalar constants and the trajectory error e is defined before:

$$d_1 I_n = D(q) d_2 I_n \quad (30)$$

$$\begin{aligned} \|C(q, \dot{q}) \dot{q} + Z(q, \dot{q})\| \\ \leq \zeta_0 + \zeta_1 \|e\| + \zeta_2 \|e\|^2. \end{aligned} \quad (31)$$

Note the similarity between (11)-(13) and (30) and (31).

Based on (30),(31), Spong [8] used Lyapunov stability theory to guarantee the ultimate boundedness of e , a concept defined in [38] for example. The control strategy is actually based on the works of Cvetkovic [35] and the linear high-gain theory of Barmish [36], Gutman [37] and Corless [38]. Spong's controller is representative of this class and is given as follows:

$$\begin{aligned} \tau &= (2 d_1 d_2) (d_1 + d_2)^{-1} \\ &\quad \cdot [\ddot{q}_d - K_2 \dot{e}_2 - K_1 \dot{e}_1 - v_r] \\ &\quad + \hat{C}(q, \dot{q}) + \hat{Z}(q, \dot{q}) \end{aligned} \quad (32)$$

where

$$v_r = \begin{cases} (B^T P e) (\|B^T P e\|)^{-1} \rho; & \text{if } \|B^T P e\| > \varepsilon \\ (B^T P e) \varepsilon^{-1} \rho; & \text{if } \|B^T P e\| \leq \varepsilon \end{cases} \quad (33)$$

and

$$\rho = (1 - \alpha)^{-1} [\alpha \|\ddot{q}_d\| + \|K_1\| \cdot \|e_1\| + \|K_2\| \cdot \|e_2\| + (d_1)^{-1} \phi] \quad (34)$$

$$\phi = \beta_0 + \beta_1 \|e\| + \beta_2 \|e\|^2 \quad (35)$$

$$\alpha = (d_2 - d_1) (d_2 + d_1)^{-1}. \quad (36)$$

Note that in the equations above, the matrix B is defined as in (2), the β_i 's are

defined as in (13), and the matrix P is the symmetric, positive-definite solution of the Lyapunov equation (37), where Q is symmetric and positive-definite matrix and A_c is given in (15):

$$A_c^T P + P A_c = -Q. \quad (37)$$

Upon closer examination of Spong's controller (32)-(36), it becomes clear that v_r depends on the servo gains K_1 and K_2 through ρ . This might obscure the effect of adjusting the servo gains and may be avoided as described in [45]. In fact, let the controller be given by

$$\tau = -K_2 \dot{e}_2 - K_1 \dot{e}_1 - v_r(\rho, e_1, e_2, \varepsilon) \quad (38)$$

where v_r is given as in (33) and

$$\rho = \delta_0 + \delta_1 \|e\| + \delta_2 \|e\|^2 \quad (39)$$

where δ_i 's are positive scalars. Note that ρ no longer contains the servo gains and as such, one may adjust K_1 and K_2 without tampering with the auxiliary control v_r . As was also shown in [45], if the initial error $e(0)=0$ and by choosing $K_2 = 2K_1 = k_r I_n$, the tracking error may be bounded by the following which shows the direct effect of the control parameters on the tracking error,

$$\|e\| \leq \left[4 \left(2k_v + \frac{3d_2}{2} \right) \varepsilon (k_v, d_1)^{-1} \right]^{1/2}. \quad (40)$$

In [44], Corless presented a simulation of a similar controller using a Manutec R3 robot. A similar control scheme was given by Chen in [39]. Chen's controller however, requires acceleration measurements. In [5], Gilbert and Ha used a saturating-type feedback derived from Lyapunov-stability theory in order to guarantee the ultimate boundedness of the tracking error. Similarly in [11], Samson derived a "high-gain" controller which guarantees the ultimate boundedness of the error.

Robust Adaptive Approach

In this section, we briefly review some approaches that combine adaptive and robust control concepts. Since so much work has been done in the field of adaptive control of robotic manipulators [1], we only concentrate on schemes that are robust in addition to being adaptive. Let us first review one of the most commonly used robot adaptive controllers. This scheme was derived by Slotine [46] and a simplified version is given by the following where $\hat{\phi}$ is an r vector of the estimated

parameters, and $Y(\cdot)$ is an $n \times r$ regression matrix of known time functions:

$$\tau = \tau_a = Y(\cdot) \hat{\phi} - K_2 e_2 - K_1 e_1 \quad (41)$$

$$\frac{d\hat{\phi}}{dt} = -Y^T(\cdot) [e_1 + e_2] \quad (42)$$

If there are no disturbances in the model (16), the tracking error is shown to be asymptotically stable with the above controller. However, the parameter estimate $\hat{\phi}$ in (42) may become unbounded in the presence of a bounded disturbance T_d or unmodeled dynamics [29],[54]. Robust-Adaptive controllers have attempted to robustify adaptive schemes against such uncertainties.

In [47], Slotine showed that the parameter estimates remain bounded if one uses

$$\tau = \tau_a + k_d \operatorname{sgn}(e_1 + e_2) \quad (43)$$

where τ_a is given in (41) and k_d is a positive scalar constant satisfying

$$k_d > \|T_d\| \quad (44)$$

More recently [48], Reed introduced the σ -modification method originated by Ioannou [49] in order to compensate for both unmodeled dynamics and bounded disturbances. The control law is now given by

$$\tau = \tau_a = Y(\cdot) \hat{\phi} - K_2 e_2 - K_1 e_1 \quad (45)$$

$$\frac{d\hat{\phi}}{dt} = -Y^T(\cdot) [e_1 + e_2] - \sigma \hat{\phi} \quad (46)$$

where

$$\sigma = \begin{cases} 0, & \text{if } \|\hat{\phi}\| < \phi_0 \\ \|\hat{\phi}\| (\phi_0)^{-1} - 1, & \text{if } \phi_0 < \|\hat{\phi}\| < 2\phi_0 \\ 1, & \text{if } \|\hat{\phi}\| > 2\phi_0 \end{cases} \quad (47)$$

and

$$\phi_0 > \|\hat{\phi}\| \quad (48)$$

Using this controller, Reed was able to show that the tracking error and all closed-loop signals are bounded.

Another approach in this section is that of Singh [50] which combines Spong's controller in (32) with adaptive techniques to estimate the uncertainty terms β_0 , β_1 , and β_2 in (35). Therefore, no prior knowledge about the exact size of the uncertainties is needed.

In [64], Spong and Ghorbel addressed certain instability mechanisms in the adaptive control of robots. A composite control law was used to damp out the fast dynamics, then a slow adaptive control law based on the algorithm of Slotine and Li [47] was robustified using the σ -modification [65]. Unfortunately,

asymptotic stability is then lost if tracking a time-varying trajectory is desired. The algorithm is modified again using the switching σ -modification to ensure the asymptotic stability to a class of time-varying trajectories.

Conclusions

The robust motion control of rigid robot was reviewed. Five main areas were identified and explained. All controllers were robust with respect to a range of uncertain parameters although some of them could only guarantee the boundedness of the position-tracking error rather than its asymptotic convergence. In the last section, we also included adaptive controllers that are also robust. The question of which robust control method to choose is difficult to answer analytically but the following guidelines are suggested. The linear-multi-variable approach is useful when linear performance specifications (Percent overshoot, Damping ratio, etc.) are available. This approach may however result in high-gain control laws in the attempt to achieve robustness. The passive controllers are easy to implement but do not provide easily quantifiable performance measures. The robust version of these controllers does not exploit the physics of the robot as their adaptive versions do. The variable-structure controllers should not be used when the flexibilities of the links are considerable for fear of exciting their high frequency dynamics. The saturation controllers, are most useful when a short transient error can be tolerated but ultimately, the error will have to be bounded. The robust adaptive controllers require more computing power and an adaptation time. On the other hand, they are most useful when repetitive or long duration tasks are performed. Their performance actually improves with time and they should be used when a high degree of performance is required. It is useful to note, that although the robot's dynamics are highly nonlinear, most successful controllers have exploited their physics and their very special structure [55],[56]. This observation should be useful as we try to include force control, and flexibility effects in the current and future robotics research.

References

[1] R. Ortega and M.W. Spong, "Adaptive motion control of rigid robots: A tutorial," *Proc. IEEE Conf. Dec. & Contr.*, pp. 1575-1584, Austin, TX, Dec. 1988.

[2] K. Kreutz, "On manipulator control by exact linearization," *IEEE Trans. Auto. Cont.*, Vol. 34, pp. 763-767, July 1989.

[3] P. Dorato, Ed., *Robust Control*. New York: IEEE Press, 1987.

[4] M.W. Spong and M. Vidyasagar, "Robust linear compensator design for nonlinear robotic control," *IEEE J. Rob. Autom.*, Vol. RA-3, pp. 345-351, Aug. 1987.

[5] E.G. Gilbert and I.J. Ha, "An approach to nonlinear feedback control with applications to robotics," *IEEE Trans. Sys., Man, and Cyber*, Vol. SMC-14, pp. 879-884, Nov./Dec. 1984.

[6] T.J. Tam, A.K. Bejczy, A. Isidori, and Y. Chen, "Nonlinear feedback in robot arm control," in *Proc. IEEE Conf. Dec. and Contr.*, Las Vegas, NV, Dec. 1984.

[7] E.J. Davison and A. Goldenberg, "The robust control of a general servomechanism problem: The servo compensator," *Automatica*, Vol. 11, pp. 461-471, 1975.

[8] M.W. Spong, J.S. Thorp, and J.M. Kleinwaks, "Robust microprocessor control of robot manipulators," *Automatica*, Vol. 23, pp. 373-379, 1987.

[9] M.S. Fadali, M. Zohdy, and B. Adamczyk, "Robust pole assignment for computed torque robotic manipulators control," in *Proc. IEEE Amer. Contr. Conf.*, June 1989, pp. 37-41.

[10] E.G. Gilbert and I.J. Ha, "Robust tracking in nonlinear systems," *IEEE Trans. Autom. Contr.*, Vol. AC-32, pp. 763-771, 1987.

[11] C. Samson, "Robust nonlinear control of robotic manipulators," in *Proc. 22nd IEEE Conf. Dec. Contr.*, San Antonio, TX, Dec. 1983, pp. 1211-1216.

[12] M.W. Spong, "Control of flexible joint robots: A survey," Rep. UILU-ENG-90-2203, DC-116, Coordinated Science Laboratory, University of Illinois at Urbana-Champaign, Feb. 1990.

[13] R.J. Anderson, "Passive Computed Torque Algorithms For Robots," *Proc. IEEE Conf. Dec. & Contr.*, Tampa, FL, Dec. 1989, pp. 1638-1644.

[14] R.J. Anderson, "A network approach to force control in robotics and teleoperation," Ph.D. thesis, Dept. Electrical and Computer Engineering, Univ. Illinois at Urbana-Champaign, 1989.

[15] V.I. Utkin, "Variable structure systems with sliding modes," *IEEE Trans. Auto. Contr.*, Vol. AC-22, pp. 212-222, Apr. 1977.

[16] K-K.D. Young, "Controller design for a manipulator using theory of variable structure systems," *IEEE Trans. Syst., Man, and Cyber*, Vol. SMC-8, pp. 210-218, Feb. 1978.

[17] J-J.E. Slotine, "The robust control of robot manipulators," *Int. J. Rob. Res.*, Vol. 4, pp. 49-64, Summer 1985.

[18] P. Dorato and R.K. Yedavali, *Recent Advances in Robust Control*. New York: IEEE Press, 1990.

[19] M.W. Spong and M. Vidyasagar, *Robot Dynamics and Control*. New York: Wiley, 1989.

[20] L. Meirovitch, *Methods of Analytical Dynamics*. New York: McGraw-Hill, 1970.

[21] P. Misra, R.V. Patel, and C.A. Balafoutis, "A robust servomechanism control scheme for tracking cartesian space trajectories," Preprint.

- [22] L.R. Hunt, R. Su, and G. Meyer, "Global transformations of nonlinear systems," *IEEE Trans. Autom. Contr.*, Vol. AC-28, pp. 24-31, 1983.
- [23] S. Desa and B. Roth, "Synthesis of control systems for manipulators using multivariable robust servo mechanism theory," *Int. J. Robotic Res.*, Vol. 4, pp. 18-34, Fall 1985.
- [24] N. Becker and W.M. Grimm, "On L_2 and L_∞ stability approaches for the robust control of robot manipulators," *IEEE Trans. Autom. Contr.*, Vol. 33, pp. 118-122, Jan. 1988.
- [25] C. Desoer and M. Vidyasagar, *Feedback Systems: Input-Output Properties*. New York: Academic, 1975.
- [26] B.D.O. Anderson et al., *Stability of Adaptive Systems: Passivity and Averaging Techniques*. Englewood Cliffs, NJ: Prentice-Hall, 1989.
- [27] M. Vidyasagar, *Control Systems Synthesis: A Factorization Approach*. Cambridge, MA, M.I.T. Press, 1985.
- [28] B.A. Francis, *A Course in H_∞ Control Theory*. Berlin: Springer-Verlag, 1987.
- [29] J.J. Craig, *Adaptive Control of Mechanical Manipulators*. Reading, MA: Addison-Wesley, 1988.
- [30] E. Freund, "Fast nonlinear control with arbitrary pole-placement for industrial robots and manipulators," *Int. J. Rob. Res.*, Vol. 1, pp. 65-78, Spring 1982.
- [31] C.Y. Kuo and S.P.T. Wang, "Nonlinear robust industrial robot control," *Trans. ASME J. Dyn. Syst. Meas. Control*, Vol. 111, pp. 24-30, Mar. 1989.
- [32] B.A. Francis and W.M. Wonham, "The internal model principle of control theory," *Automatica*, Vol. 12, pp. 457-465, 1976.
- [33] L. Cai and A.A. Goldenberg, "Robust control of position and force for a robot manipulator in non-contact and contact tasks," in *Proc. Amer. Contr. Conf.*, Pittsburgh, PA, June 1989, pp. 1905-1911.
- [34] S. Arimoto and F. Miyazaki, "Stability and robustness of pid feedback control for robot manipulators of sensory capability," in *Proc. 1st Int. Symp. Robotics Res.*, pp. 783-799, 1983.
- [35] V. Cvetkovic and M. Vukobratovic, "One robust, dynamic control algorithm for manipulation systems," *Int. J. Robotics Res.*, Vol. 1, pp. 15-28, 1982.
- [36] B.R. Barmish, I.R. Petersen, and A. Fever, "Linear ultimate boundedness control of uncertain dynamical systems," *Automatica*, Vol. 19, pp. 523-532, 1983.
- [37] S. Gutman, "Uncertain dynamic systems - A Lyapunov min-max approach," *IEEE Trans. Autom. Contr.*, Vol. AC-24, pp. 437-443, 1979.
- [38] M.J. Corless and G. Leitman, "Continuous state feedback guaranteeing uniform ultimate boundedness for uncertain dynamic systems," *IEEE Trans. Autom. Contr.*, Vol. AC-26, pp. 1139-1144, 1981.
- [39] Y.H. Chen, "On the deterministic performance of uncertain dynamical systems," *Int. J. Contr.*, Vol. 43, pp. 1557-1579, 1986.
- [40] C. Abdallah and R. Jordan, "A positive-real design for robotic manipulators," *Proc. IEEE Amer. Contr. Conf.*, San Diego, CA, May 1990.
- [41] J.J. Slotine and S.S. Sastry, "Tracking control of nonlinear systems using sliding surfaces with applications to robot manipulators," *Int. J. Contr.*, Vol. 38, pp. 465-492, 1983.
- [42] M. Whitehead and E.W. Kamen, "Control of serial manipulators with unknown variable loading," in *Proc. IEEE Conf. Dec. & Contr.*, Ft. Lauderdale, FL, Dec. 1985.
- [43] J.Y.S. Luh, "Conventional controller design for industrial robots: A tutorial," *IEEE Trans. Sys., Man, & Cyber.*, Vol. SMC-13, pp. 298-316, May/June 1983.
- [44] M. Corless, "Tracking controllers for uncertain systems: Application to a Manutec R3 robot," *J. Dyn. Sys., Meas., & Contr.*, Vol. 111, pp. 609-618, Dec. 1989.
- [45] D. Dawson and F. Lewis, "Robust and adaptive control of robot manipulators without acceleration measurement," in *Proc. IEEE Conf. Dec. & Contr.*, Tampa, FL, 1989.
- [46] J.J. Slotine and W. Li, "Theoretical issues in adaptive control," presented at Fifth Yale Workshop on Applic. of Adaptive Systems Theory, New Haven, CT, 1987.
- [47] J.J. Slotine and W. Li, "On the adaptive control of robot manipulators," *Int. J. Rob. Res.*, Vol. 3, 1987.
- [48] J. Reed and P. Ioannou, "Instability analysis and robust adaptive control of robot manipulators," in *Proc. IEEE Conf. Dec. & Contr.*, 1988, pp. 1607-1612.
- [49] P. Ioannou and K. Tsakalis, "A robust direct adaptive controller," *IEEE Trans. Auto. Contr.*, Vol. AC-31, pp. 1033-1043, Nov. 1986.
- [50] S.N. Singh, "Adaptive model following control of nonlinear robotic systems," *IEEE Trans. Auto. Contr.*, Vol. AC-30, pp. 1099-1100, Nov. 1985.
- [51] M. Corless and G. Leitmann, "Adaptive control of systems containing uncertain functions and unknown functions with uncertain bounds," *J. Optim. Theory Applic.*, Jan. 1983.
- [52] K.Y. Lim and M. Eslami, "Robust adaptive controller designs for robot manipulator systems," *IEEE Conf. Rob. & Auto.*, San Francisco, CA, Apr. 1986.
- [53] S. Nicosia and P. Tomei, "Model reference adaptive control algorithms for industrial robots," *Automatica*, pp. 635-644, May 1984.
- [54] S. Sastry and M. Bodson, *Adaptive Control: Stability, Convergence and Robustness*. Englewood Cliffs, NJ, Prentice-Hall, 1989.
- [55] J.-J.E. Slotine, "Putting physics in control - The example of robotics," *IEEE Contr. Syst. Mag.*, Vol. 8, pp. 12-17, Dec. 1988.
- [56] P.E. Crouch and A.J. van der Schaft, *Variational and Hamiltonian Control Systems*. Thoma and Wyner Ed. Berlin: Springer-Verlag, 1987.
- [57] B.E. Paden and S.S. Sastry, "A calculus for computing Filipov's differential inclusion with application to the variable structure control of robot manipulators," *IEEE Trans. Circ. Syst.*, Vol. CAS-34, pp. 73-82, Jan. 1987.
- [58] R.G. Morgan and U. Ozgunner, "A decentralized variable structure control algorithm for robotic manipulators," *IEEE J. Rob. & Auto.*, Vol. RA-1, pp. 57-65, Mar. 1985.
- [59] E. Bailey and A. Arapostathis, "Simple sliding mode control scheme applied to robot manipulators," *Int. J. Contr.*, Vol. 45, pp. 1197-1209, 1987.
- [60] G. Bartolini and T. Zolezzi, "Variable structure nonlinear in the control law," *IEEE Trans. Auto. Contr.*, Vol. AC-30, pp. 681-684, July 1985.
- [61] K.S. Yeung and Y.P. Chen, "A new controller design for manipulators using the theory of variable structure systems," *IEEE Trans. Auto. Contr.*, Vol. 33, pp. 200-206, Feb. 1988.
- [62] Y-F Chen, T. Mita, and S. Wakui, "A new and simple algorithm for sliding mode trajectory control of the robot arm," *IEEE Trans. Auto. Contr.*, Vol. 35, pp. 828-829, July 1990.
- [63] R.A. DeCarlo, S.H. Žak, and G.P. Matthews, "Variable structure control of nonlinear multi-variable systems," *IEEE Proc.*, Vol. 76, pp. 212-232, Mar. 1988.
- [64] M.W. Spong and F. Ghorbel, "Robustness of adaptive control of robots," in *Proc. Symp. Control of Robots and Manufacturing Systems*, Arlington, TX, Nov. 1990.
- [65] P.A. Ioannou and P.V. Kokotovic, "Instability analysis and improvement of robustness of adaptive control," *Automatica*, Vol. 20, pp. 583-594, 1984.



Peter Dorato is a native of New York, NY. He received his B.S.E.E. degree from the City College of New York in 1955, the M.S.E.E. degree from Columbia University in 1956, and the D.E.E. degree from the Polytechnic University (formerly

Polytechnic Institute of Brooklyn) in 1961. He was awarded a National Science Foundation faculty fellowship in 1960 to support his graduate studies at the Polytechnic University.

Dr. Dorato was a faculty member at the City College of New York from 1956 to 1957, and at the Polytechnic University from 1957 to 1972. He joined the University of Colorado at Colorado Springs as a professor and director of the Resource Systems Analysis program. In 1976, he joined the department of electrical engineering and computer science at the University of New Mexico as department chairman, where he served as chairman for eight years. He is currently professor of electrical and computer engineering at the University of New Mexico and an honorary professor at the Nanjing Aeronautical Institute.

Dr. Dorato was a member of the Control Systems Society board of governors for the following periods of time: 1970-73 and 1984-89. He has been a past associate editor of the *IEEE Transactions on Automatic Control* (1969-72, 1981-83), and was pro-

gram chairman of the 1983 American Control Conference in San Francisco, CA. He is also a past Secretary/Administrator of the Control Systems Society (1985-86) and past chairman of the Control Systems Society Education Committee (1987-88).

His areas of interest include robust control, optimization theory, and multivariable feedback systems. Dr. Dorato is a Fellow of the IEEE, cited for his contributions to sensitivity analysis and design in automatic control systems, and a Distinguished Member of the Control Systems Society, cited for his service to the society and the profession. He is currently an associate editor of *Automatica* and the *IEEE Transactions on Education*, editor of the IEEE Press Selected Reprint Volume Series, and editor of the IEEE Press volumes *Robust Control* and *Recent Results in Robust Control*.



Mohammad (Mo) Jamshidi received the B.S.E.E. degree (*cum laude*) from Oregon State University in Corvallis, OR, in June 1967; he received his M.S.E.E. and Ph.D. degrees from the University of Illinois at

Champaign-Urbana in June 1969 and February 1971, respectively. He has worked in various academic and industrial positions at the University of Illinois, Urbana, IL; Shiraz (formerly Pahlavi) University, Shiraz, Iran; University of Stuttgart, Stuttgart, Germany; IBM Research Division, Yorktown Heights, NY; Technical University of Denmark, Lyngby, Denmark; IBM information Products Division, Boulder, CO; General Motors Research Laboratories, Warren, MI; George Washington University, Washington, DC; National Institute of Standards and Technology (formerly NBS), Gaithersburg, MD; University of Virginia, Charlottesville, VA; University of Melbourne -

Australia, and the University of New Mexico, Albuquerque, NM. Presently, he is the AT&T Professor and Director of Computer-Aided Design Laboratory for Systems/Robotics within the Department of Electrical and Computer Engineering at the University of New Mexico. He is also a consultant with the U.S. Air Force Weapons Laboratory, Oak Ridge National Laboratory, and Los Alamos National Laboratory. He has over 230 technical publications including 14 textbooks and edited volumes. His latest books are *Robotics and Manufacturing* (ASME Press, 1990, coedited with M. Saif), and *Computer-Aided Analysis and Design of Linear Control Systems* (Prentice Hall, 1991, co-authored with M. Tarokh and B. Shafai). He is the Founding Editor of *IEEE Control Systems Magazine*. He is on the executive editorial boards of the *Encyclopedia of Physical Sciences and Technology*, Academic Press, *International Journal of Control and Computers*, *J. Intelligent and Robotic Systems* and *Electrosoft*. He is the editor of *Computers and Electrical Engineering - An International Journal*, Pergamon Press, Oxford and New York.

Dr. Jamshidi is a Fellow of the IEEE, recipient of the IEEE Centennial Medal and IEEE Control Systems Society Distinguished Member award, an honorary Chaired Professor of Automatic Control at Nanjing Aeronautical Institute, Nanjing, PR China, a member of Sigma Xi, Eta Kappa Nu, Tau Beta Pi, Sigma Tau, and Phi Kappa Phi honor societies, and is listed in a number of Who's Whos. He is an advisor to NASA's program on sampling and acquisition for Mars exploration.



Darren M. Dawson was born in 1962, in Macon, GA. He received an Associates Degree in Mathematics from Macon Junior College in 1982 and a B.S. Degree in Electrical Engineering, highest honors, from the Georgia Institute

of Technology in 1984. He then worked for Westinghouse as a control engineer from 1985 to 1987 where he designed control panels for the first U.S. submarine converted into a naval training vessel. In 1987, he returned to the Georgia Institute of Technology where he received the Ph.D. Degree in Electrical Engineering in March 1990. During this time, he served as a research and teaching assistant. In July 1990, he joined the Electrical Engineering Faculty at Clemson University as an Assistant Professor. He is also a member of the Center for Advanced Manufacturing that is jointly operated by the Electrical and Mechanical Engineering Departments. His main interest are control of constrained mechanical systems, nonlinear based robust, adaptive, and learning control with applications to the position and force control of robot manipulator systems.



Chaouki Abdallah received his B.E. degree in electrical engineering in 1981 from Youngstown State University, Youngstown, OH, his M.S. degree in 1982 and the Ph.D. in electrical engineering in 1988 from Georgia Tech, Atlanta, GA. Between 1983 and 1985 he was with SAWTEK Inc., Orlando, FL. Since September of 1988 he has been an assistant professor of electrical and computer engineering at the University of New Mexico, Albuquerque, NM. Dr. Abdallah was exhibit chairman of the 1990 International Conference on Acoustics, Speech, and Signal Processing (ICASSP), in Albuquerque, NM. His research interests are in the areas of nonlinear and robust control, digital control, RF control and robotics. Dr. Abdallah is a member of IEEE, Sigma Xi, and Tau Beta Pi.