

Kouloumpis, Viktor, Kouikoglou, Vassilis S. and Phillis, Yannis A. (2008) Sustainability assessment of nations and related decision making using fuzzy logic. IEEE Systems Journal, 2 (2). pp. 224-236.

Downloaded from: <http://insight.cumbria.ac.uk/id/eprint/1982/>

Usage of any items from the University of Cumbria's institutional repository 'Insight' must conform to the following fair usage guidelines.

Any item and its associated metadata held in the University of Cumbria's institutional repository Insight (unless stated otherwise on the metadata record) may be copied, displayed or performed, and stored in line with the JISC fair dealing guidelines (available [here](#)) for educational and not-for-profit activities

provided that

- the authors, title and full bibliographic details of the item are cited clearly when any part of the work is referred to verbally or in the written form
 - a hyperlink/URL to the original Insight record of that item is included in any citations of the work
- the content is not changed in any way
- all files required for usage of the item are kept together with the main item file.

You may not

- sell any part of an item
- refer to any part of an item without citation
- amend any item or contextualise it in a way that will impugn the creator's reputation
- remove or alter the copyright statement on an item.

The full policy can be found [here](#).

Alternatively contact the University of Cumbria Repository Editor by emailing insight@cumbria.ac.uk.

Sustainability assessment of nations and related decision making using fuzzy logic

Victor D. Kouloumpis, Vassilis S. Kouikoglou, *Senior Member, IEEE*, and Yannis A. Phillis, *Senior Member, IEEE*

Abstract—This paper refines and extends in fundamental ways an existing model for the numerical assessment of sustainability called SAFE (Sustainability Assessment by Fuzzy Evaluation). SAFE in its basic form uses fuzzy logic to combine a large suite of basic indicators and then computes numerical values of sustainability for a number of composite indicators such as air, land, economy, health, etc. At a higher hierarchy it computes the sustainability of an ecological and a human component, and finally it computes overall sustainability of a country or region. As state-of-the-art in fuzzy analysis has advanced we are prompted to modify SAFE accordingly.

The refined model uses the so called Takagi-Sugeno-Kang inference scheme (TSK) which together with a few technical requirements guarantee monotonicity, i.e., an improvement of a basic indicator leads to an improvement of sustainability. Another refinement concerns the data inputs. To include the effects of past environmental pressures and development policies on the present state of sustainability, we use exponential smoothing to take account of the past with exponentially decaying weights. Finally the model is now applied to all countries of the world for which data could be obtained and their corresponding sustainabilities are computed. Also, through sensitivity analysis, the most important indicators that affect sustainability are identified.

Index Terms—Sustainable development, fuzzy sustainability assessment, indicators of sustainability, sustainability of countries, sensitivity of sustainability.

I. INTRODUCTION

ECONOMIC growth cannot be sustained without preserving natural resources and keeping the social coherence. It is nowadays accepted that the economy should not develop asymmetrically at the expense of the. However, climate change and biodiversity destruction among others, provide strong evidence that development is currently unsustainable. For this reason politicians and decision makers speak more and more of sustainable rather than economic development. Roughly speaking sustainable development is human development that conserves the natural environment now and for the generations to come.

Manuscript submitted in December 25, 2007; revised in April 15, 2008. This work was supported by a HERACLITUS project of the Operational Programme for Education and Initial Vocational Training from the Greek Ministry of National Education and Religious Affairs, co-funded by the European Social Fund (75%) and National Resources (25%).

The authors are with the Department of Production Engineering and Management, Technical University of Crete, 73100 Chania, Greece (e-mail: victor.kouloumpis@gmail.com; kouik@dpem.tuc.gr; phillis@dpem.tuc.gr).

The problem of a rigorous definition of sustainable development and corresponding measuring schemes arises. SAFE [1], [2] presents such a scheme which also serves as a definition. Its goal is twofold:

- 1) To define and compute overall sustainability for a region or country given a number of basic indicators.
- 2) To compute gradients of overall sustainability with respect to basic indicators so as to identify those indicators that affect sustainability the most.

SAFE uses hierarchical fuzzy reasoning to derive sustainability values at each level of reasoning. Thanks to advances in fuzzy reasoning it became apparent that SAFE employed a reasoning scheme that did not guarantee monotonicity. A basic indicator would improve but overall sustainability wouldn't. To resolve this problem the TSK implication is introduced as we shall see below, which together with three technical conditions imposed on the rule bases and the membership functions guarantee monotonicity [3], [4].

SAFE uses two fundamental components to assess overall sustainability, ecosystem and human system. The ecosystem has four inputs, air, land, water, and biodiversity. The human system has another four inputs, economy, health, education, and policies.

It quickly became apparent that both fundamental components are not memoryless. Past concentrations of CO₂ emissions, for example, affect climate. Thus by considering the most recent value of CO₂ concentration is not good enough. A method of exponential smoothing is used to take account of the past. Past values are factored in via exponential weighting.

The fine-tuned SAFE model for the first time is used to assess the sustainability of all countries in the world for which we could find data. These countries, 128 in all, are ranked accordingly. Finally, gradients of overall sustainability with respect to basic indicators are computed and the most important indicators are identified for each country. Thus for each country we assign its sustainability index which ranges from 0 to 1, its worldwide rank, and the most critical basic indicators that affect sustainability. Politicians and decision-makers should focus mostly on these critical indicators if they are to make their countries more sustainable.

To our knowledge, SAFE is the most global model in use today to assess sustainability, in the sense that it uses the widest range of human and environmental indicators to compute overall sustainability. However, we compare our results with those of the Environmental Sustainability Index or ESI, which

has been jointly developed by Yale and Columbia Universities [5]. The reader obtains thus an idea about the impact of the presence or absence of various indicators on overall sustainability.

The remaining paper is organized as follows: Section 2 provides a short exposition into the structure of SAFE for reasons of self-containment. Section 3 gives all the refinements to SAFE with their technical details. Section 4 applies the model to 127 countries and provides overall sustainability, the sus-

tainability of ecosystem and human system, ranking, and critical basic indicators. Section 5 draws conclusions.

II. BRIEF PRESENTATION OF SAFE

In this section we present SAFE for the sake of self-sufficiency. The interested reader can find all the details in [1] and [2]. Pictorially SAFE is shown in Fig. 1.

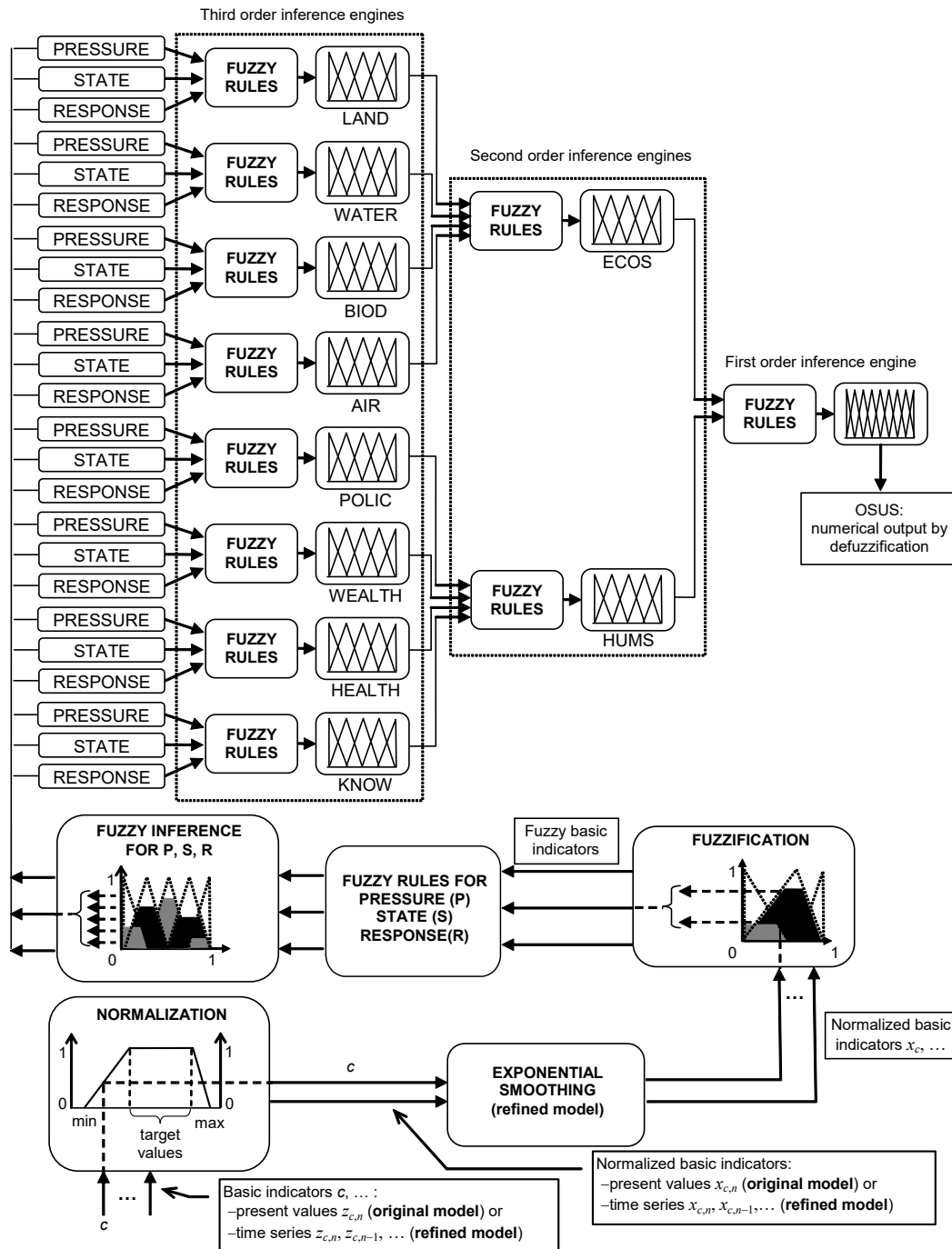

Fig. 1. Fuzzy hierarchical assessment of sustainability.

The overall sustainability (OSUS) of a system is an aggregate measure of indicators which describe various aspects and

dimensions of sustainability. OSUS has two primary components: ecological sustainability (ECOS) and human sustainability (HUMS). The ecological input comprises four secondary components: water quality (WATER), land integrity (LAND), air quality (AIR), and biodiversity (BIOD). The components of the human dimension of sustainability are political aspects (POLIC), economic welfare (WEALTH), health (HEALTH), and education (KNOW). To assess each secondary component we use the tertiary indicators PRESSURE, STATE, and RESPONSE. Each tertiary indicator is obtained by combining more specialized variables, which we call *basic* indicators. For example, the indicator STATE(AIR) which measures the state of air depends on four basic indicators of air quality: mortality from respiratory diseases and atmospheric concentrations of NO₂, SO₂ and total suspended particulates. The indicators used in the SAFE model and their definitions are given in Appendix A.

The basic indicators exhibit a variability of quality and scale that calls for normalization. Normalized values on [0, 1] are obtained by linear interpolation between the most desirable and the least desirable values, which are determined by experts. Specifically, to each basic indicator c we assign a target, a minimum, and a maximum value.

In general, the target can be any interval on the real line of the form $[\tau_c, T_c]$ representing a range of desirable values for the indicator. The maximum and minimum values, c^+ and c^- , are taken over the set of available measurements of the indicator from various countries.

Let z_c be the indicator value for the system whose sustainability we want to assess. The normalized value x_c is calculated as follows:

$$x_c = \begin{cases} \frac{z_c - c^-}{\tau_c - c^-} & c^- \leq z_c < \tau_c \\ 1 & \tau_c \leq z_c \leq T_c \\ \frac{\bar{c} - z_c}{\bar{c} - T_c} & T_c < z_c \leq \bar{c} \end{cases} \quad (1)$$

Normalized indicators are fuzzified using three fuzzy sets with linguistic values *weak* (W), *medium* (M), and *strong* (S), whose membership functions are shown in Fig. 2(a). We assign the linguistic value W to low or average values of normalized indicators. Hence, the fuzzification is somewhat pessimistic which agrees with widely accepted assessment practices. For example, according to OECD [8], water stress (PRESSURE indicator) is considered to be rather high when the intensity of use of freshwater resources per capita is greater than 40% of the total renewable resources per capita. Since the interval [40%, 100%] has a length 0.6 relative to the length of [0%, 100%] and “weak water sustainability” in the SAFE model means “high water stress,” the fuzzy set W is defined in [0, 0.6], as shown in Fig. 2(a).

The SAFE model admits any polygonal form of membership functions (triangular, trapezoidal, etc.) For composite variables and OSUS, the model uses the fuzzy sets *very bad* (VB), *bad* (B), *average* (A), *good* (G), and *very good* (VG) [see Fig. 2(b)].

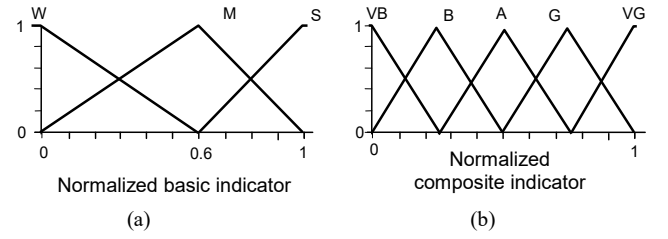

Fig. 2. Membership functions used in the original SAFE model.

Each inference engine is equipped with a collection of “if-then” linguistic rules. Examples of “if-then” rules are:

IF DOMESTICATED LAND is *medium* AND CURRENT FOREST is *weak*, THEN STATE(LAND) is *bad*;
 IF PRESSURE(LAND) is *average* AND STATE(LAND) is *good* AND RESPONSE(LAND) is *bad*, THEN LAND is *average*;
 IF LAND is *very bad* OR WATER is *very bad* OR BIOD is *very bad* OR AIR is *very bad*, THEN ECOS is *very bad*;
 IF HUMS is *good* AND ECOS is *bad*, THEN OSUS is *average*.

Consider an inference engine which combines n fuzzy inputs x_i , $i = 1, \dots, n$, to compute the composite variable x_{n+1} . A rule R_p has the form

R_p : IF (x_1 is $L_{1,p}$) AND ... AND (x_n is $L_{n,p}$), THEN (x_{n+1} is $L_{n+1,p}$)

where $L_{i,p}$ is the fuzzy set to which x_i belongs with grade $\mu_{i,p}(x_i)$. The intersection operation “and” that connects the premises of each rule is represented algebraically by the minimum of the individual truth values. Thus, the overall *firing strength* of rule R_p (degree to which R_p is applicable) is

$$\mu_{n+1,p}(x_{n+1}) = \min \{ \mu_{1,p}(x_1), \dots, \mu_{n,p}(x_n) \}. \quad (2)$$

If several rules assign the same fuzzy set L to the output variable x_{n+1} , then we must compute an overall membership grade $\mu_L(x_{n+1})$ of x_{n+1} to L . Rules having the same consequences are aggregated by the union operation, which is represented algebraically by the maximum of the individual firing strengths. So the membership grade of x_{n+1} to the fuzzy set L is

$$\mu_L(x_{n+1}) = \max_{p: L_{n+1,p}=L} \{ \mu_{n+1,p}(x_{n+1}) \} \quad (3)$$

where “ $p: L_{n+1,p}=L$ ” is an abbreviation for “all rules R_p such that their consequences assign the linguistic value L to x_{n+1} ”. Finally, a crisp value for the output is computed via the height method of defuzzification:

$$x_{n+1} = \frac{\sum_{\substack{\text{all linguistic} \\ \text{values } L \text{ of } x_{n+1}}} y_L \mu_L(x_{n+1})}{\sum_{\substack{\text{all linguistic} \\ \text{values } L \text{ of } x_{n+1}}} \mu_L(x_{n+1})} \quad (4)$$

where y_L is the *peak value* of L , that is, a value in $[0, 1]$ for which the membership function $\mu_L(x)$ is maximized. For example, from Fig. 2(b) we see that $y_{VB} = 0$, $y_B = 0.3$, and so forth.

To perform sensitivity analysis we follow the steps:

1. *Calculation of OSUS*: Compute the membership grades of composite indicators to the fuzzy sets VB, B, A, G, and VG. Start from the inference engines that use only basic indicators as inputs and proceed successively to the ones that use more composite indicators. Having computed the membership grades of OSUS, compute a crisp value for OSUS.
2. *Introduction of perturbation*: For some basic indicator $x \in [0, 1]$, increase its normalized value by some fixed amount δ (for example, 0.1 or 10%). If the result is greater than one, then truncate it to one to avoid overshooting permissible regions of indicators.
3. *Sensitivity analysis*: Assess the overall sustainability using the same set of data as in step 1 except for indicator x whose value is now $x + \delta$. Denote the new assessment by $\text{OSUS}(x + \delta)$. The gradient of OSUS with respect to x is defined by the forward difference

$$\Delta_x = \text{OSUS}(x + \delta) - \text{OSUS}.$$

Reset the basic indicator to its original value x . Repeat steps 2 and 3 for all basic indicators.

We then identify the gradients with the largest values, which correspond to the basic indicators that affect OSUS the most. By changing several indicators simultaneously in step 2 we can compute gradients of higher orders and formulate more comprehensive environmental policies. For example, the second-order gradient of OSUS with respect to indicators x and y is $\Delta_{x,y} = \text{OSUS}(x + \delta, y + \delta) - \text{OSUS}$.

III. THE REFINED MODEL

In this section we present the refinements to the original SAFE model.

A. Normalization

Apart from the target interval $[\tau_c, T_c]$ comprising the most desirable values for indicator c , it is often necessary to specify least desirable values beyond which the normalized value x_c of the indicator is zero. For example, HIV/AIDS prevalence, measured in per cent of population, has a target value $\tau_{\text{AIDS}} = T_{\text{AIDS}} = 0\%$ and a maximum value 37.3%. Even a value $z_{\text{AIDS}} = 2\%$ for this indicator is considered to be very bad. Yet, the corresponding normalized indicator is, according to (1),

$x_{\text{AIDS}} = 0.95$, that is, almost excellent.

To rectify this, we revise the meaning of the parameters $c; \bar{\quad}$ and $\underline{\quad}$ as follows. In the original model, these parameters correspond respectively to the maximum and minimum values of indicator c . In the refined model, $c; \bar{\quad}$ and $\underline{\quad}$ represent upper and lower thresholds of least desirable values. All values z_c such that $z_c \geq c; \bar{\quad}$ or $z_c \leq \underline{\quad}$ are assigned a normalized value $x_c = 0$. By setting $\text{AIDS}; \bar{\quad} = 2\%$ for example, the model returns $x_{\text{AIDS}} = 0$ for all HIV/AIDS prevalence rates $z_{\text{AIDS}} \geq 2\%$.

B. TSK inference

In the refined model the intersection and union operations are represented algebraically by products and sums. As we shall discuss later, product/sum inference ensures that, whenever an indicator is improved, the overall sustainability increases, i.e., the model is monotonic. Thus, instead of (2) and (3), we use

$$\mu_{n+1,p}(x_{n+1}) = \prod_{i=1}^n \mu_{i,p}(x_i) \quad (5)$$

$$\mu_L(x_{n+1}) = \sum_{p: L_{n+1,p}=L} \mu_{n+1,p}(x_{n+1}). \quad (6)$$

These equations together with (4) define a Takagi-Sugeno-Kang (TSK) fuzzy system [6], [7] of order zero since the peak values y_L are constants.

C. New fuzzy sets for OSUS

When the two primary components ECOS and HUMS are combined to compute OSUS, information loss is unavoidable. This happens because ECOS and HUMS, with five linguistic values each, generate $5^2 = 25$ different combinations while OSUS has only five linguistic values in the original model. Information loss can be avoided by using more linguistic values for the output. The number of linguistic values is determined as follows:

First, we assign positive weights a and b representing the relative importance respectively of ECOS and HUMS in the calculation of OSUS. We also assign integer weights $0, \dots, 4$ to the five linguistic values, such that 0 corresponds to VB, 1 corresponds to B, and so on. Each rule maps the pair (i, j) to the index of the output linguistic value k for OSUS, where $i, j \in \{0, \dots, 4\}$ and $k = ia + jb$. The minimum value of k is $0a + 0b = 0$ and the maximum value is $4a + 4b$. We choose $a = b = 1$, because we want to strike an equal balance between the environmental and the human dimensions of sustainability. Therefore k is an integer between 0 and 8. Hence the overall sustainability should have at least nine fuzzy sets, instead of five, in order to aggregate ECOS and OSUS more precisely. These fuzzy sets are: *extremely low* (EL), *very low* (VL), *low* (L), *fairly low* (FL), *intermediate* (I), *fairly high* (FH), *high* (H), *very high* (VH), and *extremely high* (EH) (see Fig. 3).

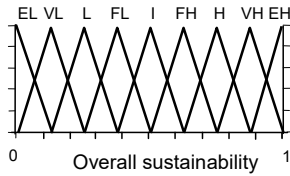

Fig. 3. Membership functions for OSUS in the refined model.

D. Why TSK is monotonic?

The fuzzy sets assigned to each basic input form a complete partition of the input domain, that is, any numerical value in $[0, 1]$ of a basic input has a positive membership grade to at least one fuzzy set. Furthermore, the collection of the fuzzy sets assigned to each variable, input or output, is an ordered set in which the binary relation $<$ is defined. For example, the fuzzy sets labeled $W = \text{weak}$, $M = \text{medium}$, $S = \text{strong}$ satisfy $W < M < S$. Moreover, for two fuzzy sets L and A , " $L \leq A$ " is used for "either $L = A$ or $L < A$."

In [3], conditions are given under which the defuzzified output of a single-stage TSK fuzzy system is a nondecreasing function of its inputs. For a system of order zero with inputs x_1, \dots, x_n and output x_{n+1} , these conditions are expressed as follows:

Condition 1: The peak values y_L of the fuzzy sets assigned to the output are nondecreasing, that is, for any two distinct fuzzy sets L and A , $L < A$ implies that $y_L \leq y_A$.

Condition 2: The rules are nondecreasing in the sense that, for any pair of rules R_p and R_q whose premises are identical except for their i th conditions being $(x_i \text{ is } L_{i,p})$ and $(x_i \text{ is } L_{i,q})$, if $L_{i,p} < L_{i,q}$, then the corresponding fuzzy sets for the output satisfy $L_{n+1,p} \leq L_{n+1,q}$.

Condition 3: The membership functions assigned to the inputs are continuous on the corresponding domains and differentiable at all but a finite number of points. Moreover, for any pair of fuzzy sets A and B , if $A < B$ then $[d\mu_A(x)/dx]/\mu_A(x) \leq [d\mu_B(x)/dx]/\mu_B(x)$, for all x where $\mu_A(x)$ and $\mu_B(x)$ are differentiable.

The peak values of the output fuzzy sets shown in Fig. 3 satisfy Condition 1. Also, the rule bases we have developed are nondecreasing. Finally, Condition 3 holds for various types of membership functions: triangular, as in Fig. 2(a), trapezoidal, Gaussian, and so on (see Lemmas 1–5 of [3]).

It should be noted that Condition 3 refers to the basic inputs; not the composite ones. Theorem 3 of [3] ensures that each inference stage that uses *only* basic inputs will produce a monotonically increasing output. For multistage TSK inference systems, however, we have discovered that the membership grades of the intermediate variables do not satisfy the inequalities of Condition 3 and, consequently, this theorem is not directly applicable to multistage inference. Nevertheless, we have been able to prove the following:

Theorem 1: In a hierarchical TSK fuzzy system, if each inference stage satisfies Conditions 1 and 2 and the basic inputs satisfy Condition 3, then the output of each stage is nondecreasing with respect to the input of the system.

Theorem 1 ensures that the model assessments agree with

intuition, that is, OSUS is an increasing function of the basic indicators of sustainability. Its proof can be found in [4].

E. Exponential Smoothing of Basic Indicators

To our knowledge existing models use the most recent indicator measurements to assess sustainability. An important problem which is partially solved in the refined SAFE model concerns the assessment of the cumulative effects of past environmental pressures, which will continue to be effective for the next years. Other problems concern the availability and accuracy of data. The values for the basic indicators in a given year are often missing or fraught with uncertainty due to measurement errors. Therefore, a systematic method is needed to improve the quality of information.

To deal with such problems we use weighted sums of present and past indicator data as inputs to the model. Let x_1, x_2, \dots, x_n be the available normalized values of indicator c in years t_1, t_2, \dots, t_n , where $t_k < t_{k+1}$. These years need not be consecutive. Then a value $x_c(n)$ of the indicator can be computed using the weighted sum $x_c(n) = w_n x_n + w_{n-1} x_{n-1} + \dots + w_1 x_1$ for some positive weights such that $w_n + w_{n-1} + \dots + w_1 = 1$. It is reasonable to assume that, although past observations play a part in $x_c(n)$, we ought to give greater weights to those that are more recent. A simple choice then is to let the weights decrease geometrically with a power equal to the difference from the most recent year t_n . This yields a single exponential smoothing model for time series (see, e.g., [9]), in which the smoothed values are given by

$$x_c(k) = \frac{x_k + x_{k-1}\beta^{t_k - t_{k-1}} + \dots + x_1\beta^{t_k - t_1}}{1 + \beta^{t_k - t_{k-1}} + \dots + \beta^{t_k - t_1}} \quad (7)$$

for $k = 1, 2, \dots, n$, where β is a number between zero and one¹.

For each country and indicator c , we compute the smoothing parameter β which minimizes the sum of squared errors (SSE), where the error $e_{k+1} = x_{k+1} - x_c(k)$ is the difference between the observation at time t_{k+1} and the estimate $x_c(k)$ from past data. We set $x_c(0) = 0$ and $x_c(1) = x_1$, so $e_1 = x_1 - 0$ and $e_2 = x_2 - x_1$ for all β . Therefore, we define $\text{SSE} = e_3^2 + \dots + e_n^2$.

To compute (7) efficiently, we observe that $x_c(k) = N(k)/D(k)$ where

$$N(k) = x_k + N(k-1)\beta^{t_k - t_{k-1}}, \quad D(k) = 1 + D(k-1)\beta^{t_k - t_{k-1}}$$

with $N(1) = x_1$ and $D(1) = 1$. The optimal value of β and the corresponding value x_c of indicator c are computed as follows:

1. *Initialization:* Let δ be a small step size for β (for example, 0.1 or 0.01). Set $\beta = 0$. For this value, (7) yields

¹ This model was proposed in [10]. In the standard exponential smoothing model, the corresponding smoothed values are $S(k) = (1 - \beta)x_k + \beta S(k-1)$ with $S(0) = 0$. When applied recursively, this yields $S(k) = x_k(1 - \beta) + x_{k-1}\beta(1 - \beta) + \dots + x_1\beta^{k-1}(1 - \beta)$. This model differs from (7) in that (i) it assumes a *complete data set*, i.e., $t_k = k$ and (ii) its weights *do not* sum up to one. However, when $n \rightarrow \infty$ the two models yield the same estimates.

$x_c(k) = x_k$ for $k = 1, \dots, n$. Initialize the optimal estimates: $\beta_c = 0$, $SSE_c = (x_3 - x_2)^2 + \dots + (x_n - x_{n-1})^2$, and $x_c = x_n$.

2. *Main loop:* Set $\beta = \beta + \delta$.
 - (i) If $\beta > 1$, then stop: the optimal smoothing parameter is β_c and the normalized indicator value is x_c ;
 - (ii) otherwise, set $SSE = 0$; initialize the numerator and denominator of (7) for $k = 2$; thus, $N = x_2 + x_1\beta^{t_2-t_1}$, $D = 1 + \beta^{t_2-t_1}$; and go to step 3.
3. *Computation of SSE:* For $k = 3, \dots, n$,
 - (i) update $SSE = SSE + (x_k - N/D)^2$;
 - (ii) update $D = 1 + D\beta^{t_k-t_{k-1}}$ and $N = x_k + N\beta^{t_k-t_{k-1}}$.
4. *Comparison:* If $SSE < SSE_c$, then update the optimal estimates, setting $x_c = N/D$, $\beta_c = \beta$, and $SSE_c = SSE$. Go to step 2.

This algorithm has minimal computational requirements as it requires less than a second on a Pentium 1.8M computer to compare 100 test values for β ($\delta=0.01$) for a total of 128 countries and 78 basic indicators each one with 16 data values (years 1990–2005).

F. Ranking of Indicators

Sensitivity analysis using gradients pinpoints those parameters that affect sustainability critically. This approach is biased towards indicators which belong to small groups. For example, the state of biodiversity, STATE(BIOD), depends only on forest area. Therefore, an increase in the latter directly affects the former. PRESSURE(BIOD), on the other hand, depends on six basic indicators, which describe the extinction rates of animal and plant species (see Appendix A). An improvement of one of these indicators will result in a small improvement of PRESSURE(BIOD).

To avoid this difficulty, a basic indicator c is ranked according to the product

$$D_c = (1 - x_c)\Delta_c, \tag{8}$$

where x_c is the normalized value of indicator c , $1 - x_c$ is its distance from the sustainable value, and $\Delta_c = OSUS(x_c + \delta) - OSUS(x_c)$ is the gradient of OSUS with respect to x_c . Thus those indicators that affect OSUS the most and are farther in the unsustainable region are pinpointed and ranked accordingly.

G. An Example

We present a numerical example to illustrate how the model assesses sustainability. Table I shows the time series $z_{c,n}$ of four basic indicators for Greece: *Mortality from respiratory diseases* and *Atmospheric concentrations of NO₂, SO₂, and total suspended particulates*. These indicators affect the composite indicator STATE(AIR) as explained in Appendix A, and are numbered $c = 26, 27, 28,$ and 29 respectively. The least desirable values for these indicators are the maxima of all countries and the target values are zero. We compute the cor-

responding normalized values $x_{c,n}$ from (1). The algorithm of Section III.E gives the optimal parameter β_c and estimate x_c for each indicator. Finally, the membership grades of x_c to the fuzzy sets *weak*, *medium*, and *strong* shown in Fig. 2(a) are displayed in the last three rows of Table I.

TABLE I
FOUR INDICATORS FOR GREECE: ORIGINAL AND NORMALIZED TIME SERIES, EXPONENTIALLY SMOOTHED ESTIMATES, AND MEMBERSHIP GRADES

Indicator c	26	27	28	29				
max, $c_i =$	132.72	109.16	209	473				
target, $t_c = T_c$	0	0	0	0				
YEAR t_n	$z_{c,n}$	$x_{c,n}$	$z_{c,n}$	$x_{c,n}$	$z_{c,n}$	$x_{c,n}$	$z_{c,n}$	$x_{c,n}$
1990	50.89	0.617	n/a	n/a	n/a	n/a	n/a	n/a
1991	52.07	0.608	n/a	n/a	n/a	n/a	n/a	n/a
1992	60.06	0.547	n/a	n/a	n/a	n/a	n/a	n/a
1993	54.22	0.591	n/a	n/a	n/a	n/a	n/a	n/a
1994	52.22	0.607	n/a	n/a	n/a	n/a	n/a	n/a
1995	55.15	0.584	64.0	0.414	34.00	0.837	178.0	0.624
1996	54.52	0.589	64.0	0.414	34.00	0.837	178.0	0.624
1997	52.33	0.606	n/a	n/a	n/a	n/a	n/a	n/a
1998	63.75	0.520	n/a	n/a	n/a	n/a	n/a	n/a
1999	66.73	0.497	n/a	n/a	n/a	n/a	n/a	n/a
2000	73.33	0.448	n/a	n/a	n/a	n/a	n/a	n/a
2001	64.14	0.517	n/a	n/a	n/a	n/a	n/a	n/a
2002	69.74	0.475	n/a	n/a	n/a	n/a	n/a	n/a
2003	n/a	n/a	n/a	n/a	n/a	n/a	n/a	n/a
2004	n/a	n/a	58.8	0.461	13.16	0.937	58.79	0.876
2005	n/a	n/a	n/a	n/a	n/a	n/a	n/a	n/a
parameter β_c	0.28		0.00		0.01		0.49	
estimate x_c	0.482		0.461		0.937		0.874	
μ_w	0.20		0.23		0.00		0.00	
μ_M	0.80		0.77		0.16		0.31	
μ_s	0.00		0.00		0.84		0.69	

TABLE II
RULES AND CORRESPONDING FIRING STRENGTHS FOR THE STATE OF AIR IN GREECE

Rule	if	and	and	and	then	with
R_p	x_{26}	x_{27}	x_{28}	x_{29}	STATE(AIR)	grade
	is	is	is	is	is	(from equation (4))
R_5	W	W	M	M	VB	$0.20 \times 0.23 \times 0.16 \times 0.31 = 0.002$
R_6	W	W	M	S	B	$0.20 \times 0.23 \times 0.16 \times 0.69 = 0.005$
R_8	W	W	S	M	B	$0.20 \times 0.23 \times 0.84 \times 0.31 = 0.012$
R_9	W	W	S	S	A	$0.20 \times 0.23 \times 0.84 \times 0.69 = 0.027$
R_{14}	W	M	M	M	B	$0.20 \times 0.77 \times 0.16 \times 0.31 = 0.008$
R_{15}	W	M	M	S	A	$0.20 \times 0.77 \times 0.16 \times 0.69 = 0.017$
R_{17}	W	M	S	M	A	$0.20 \times 0.77 \times 0.84 \times 0.31 = 0.040$
R_{18}	W	M	S	S	G	$0.20 \times 0.77 \times 0.84 \times 0.69 = 0.089$
R_{32}	M	W	M	M	B	$0.80 \times 0.23 \times 0.16 \times 0.31 = 0.009$
R_{33}	M	W	M	S	A	$0.80 \times 0.23 \times 0.16 \times 0.69 = 0.020$
R_{35}	M	W	S	M	A	$0.80 \times 0.23 \times 0.84 \times 0.31 = 0.048$
R_{36}	M	W	S	S	G	$0.80 \times 0.23 \times 0.84 \times 0.69 = 0.107$
R_{41}	M	M	M	M	A	$0.80 \times 0.77 \times 0.16 \times 0.31 = 0.031$
R_{42}	M	M	M	S	G	$0.80 \times 0.77 \times 0.16 \times 0.69 = 0.068$
R_{44}	M	M	S	M	G	$0.80 \times 0.77 \times 0.84 \times 0.31 = 0.160$
R_{45}	M	M	S	S	VG	$0.80 \times 0.77 \times 0.84 \times 0.69 = 0.357$

The rule base for STATE(AIR) is shown in Table VII, Appendix B. Since each of the four inputs belongs to two fuzzy sets, only $2^4 = 16$ rules of the rule base fire, as shown in Table II.

By summing the firing strengths of the rules that assign the

same fuzzy set to the output, we obtain the membership grades of STATE(AIR) to the fuzzy sets VB, B, A, G, and VG. Thus, we have $\mu_{VB} = 0.002$, $\mu_B = 0.034$, $\mu_A = 0.183$, $\mu_G = 0.424$, $\mu_{VG} = 0.357$.

By a similar procedure we compute the membership grades of all composite indicators for Greece to the corresponding fuzzy sets. The membership grades of the overall sustainability to the nine fuzzy sets of Fig. 3 are $\mu_{EL} = \mu_{VL} = \mu_L = 0$, $\mu_{FL} = 0.006$, $\mu_I = 0.454$, $\mu_{FH} = 0.540$, and $\mu_H \approx \mu_{VH} = \mu_{EH} = 0$.

Finally, by applying (4), we obtain a crisp value for OSUS as follows:

$$OSUS = \frac{0.375 \times 0.006 + 0.5 \times 0.454 + 0.625 \times 0.540}{0.006 + 0.454 + 0.540} = 0.567.$$

IV. RESULTS

A. Sustainability of Countries

Table III shows the overall, ecological, and human sustainability assessments for 128 countries. An inclusion of all 192 member states of the United Nations in the study was not possible due to unavailability of data. Many countries have not developed suitable data collection mechanisms. Countries with small area and population as well as countries suffering from

natural disasters or war over the last decade are typical cases. Also it is impossible to obtain data for countries that became independent recently while previously they belonged to larger states. Data are available for these larger states, e.g., the Soviet Union, but not for the newly formed countries.

The ten highest-ranking countries are Sweden, Finland, Switzerland, Austria, Lithuania, Latvia, Slovakia, Germany, Norway, and Netherlands.

B. Sensitivity Analysis

Table IV shows the two most important indicators obtained by means of a first-order sensitivity analysis of OSUS and (8) for selected countries. The critical factors for most developed countries are ecological (renewable energy production, greenhouse gas emissions, and forest change). For less developed countries the most important factors are ecological as well as human (economical, political, and educational).

C. Comparison with ESI

The rankings of countries from most sustainable to less sustainable according to SAFE and the ESI are shown in Table V. It is noted that half of the countries in the top ten positions are the same for both models. However, for other countries, the ESI rankings differ significantly from those of SAFE.

TABLE III
SUSTAINABILITY RANKING OF 128 COUNTRIES (DATA FOR 1990–2005)

COUNTRY	OSUS	ECOS	HUMS	COUNTRY	OSUS	ECOS	HUMS	COUNTRY	OSUSECOS	HUMS	COUNTRY	OSUS	ECOS	HUMS	
1. Finland	0.836	0.694	0.977	33. Bulgaria	0.551	0.485	0.638	65. Jordan	0.472	0.441	0.504	97. Ecuador	0.390	0.522	0.259
2. Austria	0.776	0.736	0.817	34. Uruguay	0.550	0.573	0.526	66. Benin	0.469	0.722	0.215	98. Turkey	0.389	0.500	0.278
3. Sweden	0.761	0.748	0.773	35. Croatia	0.550	0.500	0.599	67. C. African Rep.	0.468	0.733	0.204	99. Angola	0.388	0.695	0.080
4. Switzerland	0.752	0.737	0.766	36. Panama	0.542	0.703	0.382	68. Colombia	0.465	0.527	0.404	100. Kuwait	0.388	0.367	0.416
5. Latvia	0.745	0.745	0.744	37. Thailand	0.541	0.586	0.496	69. Gambia	0.463	0.676	0.250	101. Syria	0.382	0.495	0.269
6. Norway	0.741	0.633	0.849	38. Romania	0.539	0.582	0.497	70. Cote d' Ivoire	0.458	0.679	0.238	102. Indonesia	0.376	0.499	0.253
7. Netherlands	0.710	0.500	0.920	39. Kyrgyzstan	0.533	0.582	0.485	71. Tajikistan	0.457	0.648	0.266	103. Uzbekistan	0.375	0.430	0.320
8. Lithuania	0.709	0.668	0.749	40. FYROM (Former Yugoslav Rep. of Macedonia)	0.524	0.556	0.491	72. Namibia	0.457	0.596	0.317	104. Mozambique	0.374	0.700	0.048
9. Slovakia	0.705	0.659	0.750	41. Albania	0.521	0.655	0.386	73. Senegal	0.456	0.700	0.211	105. Togo	0.374	0.519	0.229
10. Germany	0.674	0.577	0.772	42. Kazakhstan	0.519	0.542	0.495	74. Zimbabwe	0.454	0.661	0.249	106. Guatemala	0.374	0.528	0.219
11. Denmark	0.673	0.595	0.750	43. Botswana	0.516	0.742	0.290	75. Georgia	0.452	0.554	0.349	107. Cambodia	0.370	0.585	0.156
12. Czech Rep.	0.665	0.581	0.750	44. Chile	0.511	0.507	0.516	76. Morocco	0.441	0.485	0.398	108. Burkina Faso	0.366	0.636	0.097
13. France	0.661	0.510	0.811	45. Peru	0.507	0.584	0.431	77. Papua N. Guinea	0.437	0.624	0.250	109. Laos	0.362	0.551	0.174
14. Canada	0.658	0.551	0.765	46. Moldova	0.507	0.513	0.500	78. El Salvador	0.437	0.504	0.370	110. Egypt	0.362	0.338	0.386
15. New Zealand	0.648	0.500	0.796	47. Belarus	0.507	0.504	0.509	79. Sri Lanka	0.435	0.500	0.371	111. India	0.362	0.506	0.221
16. Estonia	0.640	0.672	0.607	48. Tunisia	0.504	0.500	0.509	80. Paraguay	0.434	0.598	0.270	112. Sierra Leone	0.354	0.589	0.119
17. Portugal	0.634	0.518	0.750	49. Ukraine	0.504	0.503	0.504	81. D. R. Congo	0.433	0.616	0.250	113. Sudan	0.345	0.516	0.175
18. Hungary	0.629	0.509	0.750	50. Armenia	0.501	0.528	0.474	82. Saudi Arabia	0.432	0.431	0.440	114. Oman	0.345	0.260	0.430
19. UK	0.628	0.500	0.756	51. Gabon	0.500	0.749	0.250	83. Ghana	0.430	0.610	0.250	115. Madagascar	0.344	0.506	0.182
20. Ireland	0.627	0.483	0.772	52. Russia	0.499	0.500	0.498	84. Zambia	0.428	0.749	0.107	116. Algeria	0.341	0.398	0.285
21. Italy	0.626	0.502	0.750	53. Mongolia	0.498	0.506	0.491	85. Rwanda	0.421	0.736	0.106	117. Bangladesh	0.336	0.500	0.172
22. Australia	0.626	0.490	0.762	54. Venezuela	0.494	0.561	0.427	86. Azerbaijan	0.419	0.505	0.334	118. Guinea	0.331	0.553	0.108
23. USA	0.625	0.500	0.750	55. Argentina	0.493	0.504	0.483	87. Un. Arab Emirates	0.419	0.250	0.588	119. Pakistan	0.322	0.471	0.172
24. Slovenia	0.623	0.496	0.750	56. Mexico	0.492	0.500	0.486	88. Vietnam	0.414	0.502	0.325	120. Ethiopia	0.304	0.607	0.002
25. Japan	0.623	0.496	0.750	57. China	0.491	0.495	0.488	89. Guinea Bissau	0.413	0.624	0.202	121. Nigeria	0.296	0.509	0.083
26. Spain	0.621	0.486	0.755	58. Bolivia	0.485	0.715	0.255	90. Uganda	0.409	0.577	0.241	122. Mali	0.288	0.502	0.074
27. Belgium	0.615	0.480	0.750	59. S. Africa	0.484	0.491	0.477	91. Honduras	0.407	0.519	0.298	123. Iran	0.283	0.282	0.288
28. Israel	0.607	0.476	0.738	60. Lebanon	0.481	0.468	0.494	92. Kenya	0.406	0.647	0.166	124. Niger	0.282	0.517	0.046
29. Poland	0.595	0.632	0.558	61. Brazil	0.480	0.522	0.438	93. Philippines	0.401	0.497	0.305	125. Mauritania	0.278	0.487	0.070
30. South Korea	0.585	0.486	0.684	62. Congo	0.477	0.703	0.250	94. Cameroon	0.398	0.595	0.202	126. Chad	0.277	0.539	0.015
31. Greece	0.567	0.497	0.647	63. Nicaragua	0.475	0.696	0.253	95. Nepal	0.397	0.614	0.181	127. Burundi	0.257	0.500	0.015
32. Malaysia	0.552	0.500	0.605	64. Tanzania	0.474	0.721	0.226	96. Malawi	0.397	0.660	0.135	128. Yemen	0.229	0.433	0.025

TABLE IV
TWO MOST IMPORTANT BASIC INDICATORS FOR SELECTED COUNTRIES (FIRST-ORDER SENSITIVITY ANALYSIS)

COUNTRY: Indicators	COUNTRY: Indicators	COUNTRY: Indicators
USA: Renewable energy production, Greenhouse gas emissions.	POLAND: Forest change, GNI per capita.	VENEZUELA: Fertilizer consumption, Forest change.
SPAIN: Forest change, Protected area	GREECE: Public expenditure on R&D, Foreign direct investment.	ECUADOR: Fertilizer consumption, Renewable energy production.
BELGIUM: Renewable energy production, Forest change.	ROMANIA: Protected area, Renewable energy production.	CAMBODIA: Environmental laws and enforcement, Ratio of refugees.
IRELAND: Renewable energy production, Forest change.	BOTSWANA: Unemployment, GNI per capita.	

TABLE V
SAFE-ESI SUSTAINABILITY RANKINGS OF COUNTRIES.

Rank	SAFE	ESI	Rank	SAFE	ESI	Rank	SAFE	ESI
1	Finland	Finland	50	Armenia	Cameroon	99	Angola	Azerbaijan
2	Austria	Norway	51	Gabon	Ecuador	100	Kuwait	Kenya
3	Sweden	Uruguay	52	Russia	Laos	101	Syria	India
4	Switzerland	Sweden	53	Mongolia	Cuba	102	Indonesia	Poland
5	Latvia	Iceland	54	Venezuela	Hungary	103	Uzbekistan	Niger
6	Norway	Canada	55	Argentina	Tunisia	104	Mozambique	Chad
7	Netherlands	Switzerland	56	Mexico	Georgia	105	Togo	Morocco
8	Lithuania	Guyana	57	China	Uganda	106	Guatemala	Rwanda
9	Slovakia	Argentina	58	Bolivia	Moldova	107	Cambodia	Mozambique
10	Germany	Austria	59	South Africa	Senegal	108	Burkina Faso	Ukraine
11	Denmark	Brazil	60	Lebanon	Zambia	109	Laos	Jamaica
12	Czech Rep.	Gabon	61	Brazil	Bosnia Herzegovina	110	Egypt	United Arab Emirates
13	France	Australia	62	Congo	Israel	111	India	Togo
14	Canada	New Zealand	63	Nicaragua	Tanzania	112	Sierra Leone	Belgium
15	New Zealand	Latvia	64	Tanzania	Madagascar	113	Sudan	D. Rep. of Congo
16	Estonia	Peru	65	Jordan	UK	114	Oman	Bangladesh
17	Portugal	Paraguay	66	Benin	Nicaragua	115	Madagascar	Egypt
18	Hungary	Costa Rica	67	Central African Rep.	Greece	116	Algeria	Guatemala
19	UK	Croatia	68	Colombia	Cambodia	117	Bangladesh	Syria
20	Ireland	Bolivia	69	Gambia	Italy	118	Guinea	El Salvador
21	Italy	Ireland	70	Cote d' Ivoire	Bulgaria	119	Pakistan	Dominican Republic
22	Australia	Lithuania	71	Tajikistan	Mongolia	120	Ethiopia	Sierra Leone
23	USA	Colombia	72	Namibia	Gambia	121	Nigeria	Liberia
24	Slovenia	Albania	73	Senegal	Thailand	122	Mali	South Korea
25	Japan	Central African Rep.	74	Zimbabwe	Malawi	123	Iran	Angola
26	Spain	Denmark	75	Georgia	Indonesia	124	Niger	Mauritania
27	Belgium	Estonia	76	Morocco	Spain	125	Mauritania	Philippines
28	Israel	Panama	77	Papua New Guinea	Guinea Bissau	126	Chad	Libya
29	Poland	Slovenia	78	El Salvador	Kazakhstan	127	Burundi	Vietnam
30	South Korea	Japan	79	Sri Lanka	Sri Lanka	128	Yemen	Zimbabwe
31	Greece	Germany	80	Paraguay	Kyrgyzstan	129		Lebanon
32	Malaysia	Namibia	81	D. Rep. of Congo	Guinea	130		Burundi
33	Bulgaria	Russia	82	Saudi Arabia	Venezuela	131		Pakistan
34	Uruguay	Botswana	83	Ghana	Oman	132		Iran
35	Croatia	Papua New Guinea	84	Zambia	Jordan	133		China
36	Panama	France	85	Rwanda	Nepal	134		Tajikistan
37	Thailand	Portugal	86	Azerbaijan	Benin	135		Ethiopia
38	Romania	Malaysia	87	United Arab Emirates	Honduras	136		Saudi Arabia
39	Kyrgyzstan	Congo	88	Vietnam	Cote d' Ivoire	137		Yemen
40	FYROM	Netherlands	89	Guinea Bissau	Serbia and Montenegro	138		Kuwait
41	Albania	Mali	90	Uganda	FYROM	139		Trinidad and Tobago
42	Kazakhstan	Chile	91	Honduras	Turkey	140		Sudan
43	Botswana	Bhutan	92	Kenya	Czech Rep.	141		Haiti
44	Chile	Armenia	93	Philippines	South Africa	142		Uzbekistan
45	Peru	USA	94	Cameroon	Romania	143		Iraq
46	Moldova	Myanmar	95	Nepal	Mexico	144		Turkmenistan
47	Belarus	Belarus	96	Malawi	Algeria	145		Taiwan
48	Tunisia	Slovakia	97	Ecuador	Burkina Faso	146		North Korea
49	Ukraine	Ghana	98	Turkey	Nigeria			

In general, developed countries seem to enjoy higher ranking in SAFE because of their good human sustainability scores, while the opposite holds for most African, Latin American and Asian countries. This is so because the two approach-

es use different methods for aggregating indicator values and also because ESI focuses mainly on the environmental dimension of sustainability. As Fig. 1 shows, half of the main components of sustainability (Policy, Wealth, Health and

Knowledge) and more than half of the basic indicators used in the SAFE model concern human sustainability. This is why countries with a low human index as, for example, Uruguay, Gabon or Peru which have high ESI scores do not rank well enough in SAFE. Although ESI includes components such as “private sector responsiveness” and “science and technology,” it focuses mainly on the environmental part of sustainability. Indicators that affect human sustainability are aggregated into a single component called “social and institutional capacity”. This component is based on the assumption that a country is more likely to be environmentally sustainable if it has in place institutions and underlying social patterns of skills, attitudes, and networks that foster effective responses to environmental challenges. SAFE on the other hand uses indicators which capture both dimensions of sustainability, the ecological and the human, and provides a broader picture of sustainability and sustainable development.

V. CONCLUSIONS

A model called SAFE is presented for the assessment of sustainability of countries which uses fuzzy logic to aggregate indicators of human welfare and environmental degradation. To our knowledge SAFE is the only model that can identify, through sensitivity analysis, the most important indicators that affect sustainability.

The SAFE approach provides new insights of sustainable development and it may serve as a practical tool for decision-making and policy design at the local or regional levels. Such approaches are urgently needed nowadays if we want to attack the problem of sustainable development systematically.

APPENDIX A INDICATORS OF SUSTAINABILITY

We summarize the basic indicators used to assess the tertiary components of sustainability, PRESSURE, STATE, and RESPONSE. Definitions of indicators are taken from [11]–[24] and [5].

A. LAND Indicators

PRESSURE(LAND)

⁽¹⁾ *Municipal waste generation* (kg per capita per year): Waste collected and treated by or for municipalities. It covers waste from households, including bulky waste, similar waste from commerce and trade, office buildings, institutions and small businesses, yard and garden waste, street sweepings, the contents of litter containers, and market cleaning waste. The definition excludes waste from municipal sewage networks and treatment, as well as municipal construction and demolition waste. Reducing waste generation improves land sustainability.

⁽²⁾ *Nuclear waste* (tons of heavy metals per capita per year): Nuclear waste presents annual spent fuel arising in nuclear power plants of OECD countries. It is assumed that nuclear

energy production influences land sustainability negatively due mainly to generation of heavy metals.

⁽³⁾ *Hazardous waste* (tons of waste per capita per year): Definitions used in these data refer to the waste streams to be controlled according to the Basel Convention on the Control of Transboundary Movements of Hazardous Wastes and their Disposal. Reducing waste generation improves land sustainability.

⁽⁴⁾ *Population growth rate* (percentage): Average annual exponential rate of population change for given periods of years. Small or zero population growth rate is perceived as influencing positively land sustainability.

⁽⁵⁾ *Pesticide consumption* (kg pesticide consumption per hectares of arable land): Pesticide use intensity refers to the amount of pesticide used per hectare of arable and permanent cropland. Excessive use of pesticides in agricultural activities has negative impacts on soil, water, humans and wildlife.

⁽⁶⁾ *Fertilizer consumption* (100 grams fertilizer per hectare of arable land): Fertilizer consumption measures the quantity of plant nutrients used per unit of arable land and these products cover nitrogenous, potash, and phosphate fertilizers (including ground rock phosphate). Excessive use of fertilizers from agricultural activities has a negative impact on soil and water, altering chemistry and levels of nutrients and leading to eutrophication of water bodies.

STATE(LAND)

⁽⁷⁾ *Desertification of land* (percent of dryland area): Areas with a potential hazard of desertification. All the major continents face problems of land degradation in dryland areas, commonly known as desertification. Dryland areas are ‘fragile’ in that they are extremely vulnerable to land degradation resulting from over-grazing and other forms of inappropriate land use.

⁽⁸⁾ *Forest area* (percent of what existed in the year 2000): Forest area is land under natural or planted stands of trees, whether productive or not. Forests maintain land sustainability.

RESPONSE(LAND)

⁽⁹⁾ *Forest change* (annual rate of change): Forest area change is the net change in forests and includes expansion of forest plantations and losses and gains in the area of natural forests. A positive forest change improves land sustainability.

⁽¹⁰⁾ *Protected area* (ratio to surface area): An area of land and/or sea especially dedicated to the protection and maintenance of biological diversity, and of natural and associated cultural resources, and managed through legal or other effective means [23]. Protected area ensures land sustainability.

^(11, 12) *Recycling rates: glass¹¹, paper¹²* (percent of apparent consumption): Recycling rates are the ratios of the quantity collected for recycling to the apparent consumption. Reducing uncontrolled waste improves land sustainability.

B. WATER Indicators

PRESSURE(WATER)

⁽¹³⁾ *Total water withdrawals* (percent of total renewable resources): Total annual amount of water withdrawn per amount of renewable water resources. Excessive use of water reduces water sustainability.

⁽⁵⁾ *Pesticide consumption*

⁽⁶⁾ *Fertilizer consumption*

STATE(WATER)

⁽¹⁴⁾ *Organic water pollutant (BOD, biological oxygen demand) emissions* (kg per capita per day): Emissions of organic water pollutants are measured by biochemical oxygen demand, which refers to the amount of oxygen that bacteria in water will consume in breaking down waste. This is a standard water-treatment test for the presence of organic pollutants.

⁽¹⁵⁾ *Phosphorus concentration* (mg phosphorus per liter of water). It is a measure of eutrophication, which affects the health of aquatic resources. High levels correspond to high levels of eutrophication.

⁽¹⁶⁾ *Metals concentration* (micro-Siemens per centimeter): It is a widely used bulk measure of metals concentration and salinity. High levels of conductivity correspond to high concentrations of metals.

RESPONSE(WATER)

⁽¹⁷⁾ *Public wastewater treatment plants* (percent of population connected): Connected means actually connected to a waste water treatment plant through a public sewage network. Non-public treatment plants, i. e. industrial waste water plants, or individual private treatment facilities such as septic tanks are not covered here. High connectivity improves water sustainability.

C. BIODIVERSITY Indicators

PRESSURE(BIOD)

⁽¹⁸⁻²³⁾ *Threatened bird*¹⁸, *mammal*¹⁹, *plant*²⁰, *fish*²¹, *amphibian*²², and *reptile*²³ species (percentage): Includes all species that are critically endangered, endangered, or vulnerable, but excludes introduced species, species whose status is insufficiently known, those known to be extinct, and those for which a status has not been assessed.

STATE(BIOD)

⁽⁷⁾ *Forest area*

RESPONSE(BIOD)

⁽⁹⁾ *Forest change*

⁽¹⁰⁾ *Protected area*

D. AIR Indicators

PRESSURE(AIR)

⁽²⁴⁾ *Ozone depleting substances per capita* (consumption in Ozone Depleting Potential metric tons): Ozone depleting substance is any substance containing chloride or bromine, which destroys the atmospheric ozone layer that absorbs most of the biologically damaging ultraviolet radiation. Ozone depletion potential refers to the amount of ozone depletion caused by a substance.

⁽²⁵⁾ *Greenhouse gas emissions per capita* (tons of CO₂ equivalent). Emissions of total GHG (CO₂, CH₄, N₂O, HFCs, PFCs and SF₆), excluding land-use change and forestry. The Global Warming Potential (GWP) is an index used to translate the level of emissions of various gases into a common measure in order to compare the relative radiative forcing of different gases without directly calculating the changes in atmospheric concentrations.

STATE(AIR)

⁽²⁶⁾ *Mortality from respiratory diseases* (number of deaths per 100,000 persons). Diseases of the respiratory system generally cause irritation and reduced lung function with increased incidence of respiratory disease, especially in more susceptible members of the population such as young children, the elderly and asthmatics.

⁽²⁷⁻²⁹⁾ *Atmospheric concentrations of NO₂*²⁷, *SO₂*²⁸ and *total suspended particulates*²⁹ (µg/m³): The values were originally collected at the city level. The number of cities with data provided by each country varies. Within each country the values have been normalized by city population for the year 1995, and then summed to give the total concentration for the given country. High concentrations decrease air sustainability.

RESPONSE(AIR)

⁽³⁰⁾ *Renewable resources production as a percentage of total primary energy supply*: The higher the proportion of hydroelectric and renewable energy sources, the less reliance on more environmentally damaging sources such as fossil fuel and nuclear energy.

E. POLICY Indicators

PRESSURE(POLICY)

⁽³¹⁾ *Military spending* (percent of GDP): For members of the North Atlantic Treaty Organization (NATO) it is based on the NATO definition, which covers military-related expenditures of the defense ministry and other ministries. Civilian-type expenditures of the defense ministry are excluded. Military assistance is included in the expenditure of the donor country. Purchases of military equipment on credit are recorded at the time the debt is incurred, not at the time of payment. Data for non-NATO countries generally cover expenditure of the ministry of defense; excluded are expenditures on public order and safety, which are classified separately.

⁽³²⁾ *Ratio of refugees from a country to total population of that country*: Refugees are people who are recognized as refugees under the 1951 Convention Relating to the Status of Refugees or its 1967 Protocol, the 1969 Organization of African Unity Convention Governing the Specific Aspects of Refugee Problems in Africa, people recognized as refugees in accordance with the UNHCR statute, people granted a refugee-like humanitarian status, and people provided with temporary protection.

⁽³³⁾ *Urban population under poverty line* (percent): Urban poverty rate is the percentage of the urban population living below the national urban poverty line based on the World Bank's country poverty assessments.

STATE(POLICY)

⁽³⁴⁾ *Political Rights*: The Freedom House Annual Survey employs the Political Rights checklist to help determine the degree to which people can participate in the political process of their country. Each country is then rated on a seven-category scale, 1 representing the most free and 7 the least free.

⁽³⁵⁾ *Civil Liberties*: The Freedom House Annual Survey employs a Civil Liberties checklist to help monitor the progress and decline of human rights worldwide. Each country is rated on a seven-category scale, 1 representing the most free and 7 the least free.

⁽³⁶⁾ *Gini index*: Measures the extent to which the distribution of income among individuals or households within an economy deviates from a perfectly equal distribution. A Gini index of zero would represent perfect equality and an index of 100 would imply perfect inequality—a single person or household accounting for all income or consumption.

⁽³⁷⁾ *Transparency International Corruption Perception Index*

RESPONSE(POLICY)

⁽³⁸⁾ *Environmental laws and enforcement*: Measurement ranging from zero to one that is obtained by a subjective assessment on the basis of various world reports and authors' knowledge. Convention on biological diversity; Ramsar convention on wetlands of international importance; Convention on International Trade of Endangered Species (CITES) of Wild Fauna and Flora; national environmental laws; etc.

⁽³⁹⁾ *Tax revenue* (percent of GDP): Tax revenue refers to compulsory transfers (payments) to the central government for public purposes. Certain compulsory transfers such as fines, penalties, and most social security contributions are excluded. Refunds and corrections of erroneously collected tax revenue are treated as negative revenue.

F. WEALTH Indicators

PRESSURE(WEALTH)

⁽⁴⁰⁾ *GDP implicit deflator* (average annual percent growth rates): Reflects changes in prices for all final demand categories, such as government consumption, capital formation, and international rate, as well as the main component, private final consumption. It is derived as the ratio of current to constant-price GDP. It is known as inflation indicator affecting the sustainability of a national economy.

⁽⁴¹⁾ *Imports* (million dollars per capita): Shows the cost plus insurance and freight value in U.S. dollars of goods purchased from the rest of the world.

⁽⁴²⁾ *Unemployment*: Unemployment refers to the share of the labor force that is without work but available for and seeking employment. Definitions of labor force and unemployment differ by country.

⁽⁴³⁾ *Unemployment equality gap between genders*: This variable shows the absolute difference between unemployment rate for female and male labor force.

STATE(WEALTH)

⁽⁴⁴⁾ *Central governmental debt* (percent of GDP): Debt is the entire stock of direct government fixed-term contractual obli-

gations to others outstanding on a particular date. It includes domestic and foreign liabilities such as currency and money deposits, securities other than shares, and loans. It is the gross amount of government liabilities reduced by the amount of equity and financial derivatives held by the government. Because debt is a stock rather than a flow, it is measured as of a given date, usually the last day of the fiscal year.

⁽⁴⁵⁾ *GNI per capita* (based on purchasing power parity (PPP)). PPP GNI is gross national income (GNI) converted to international dollars using purchasing power parity rates. An international dollar has the same purchasing power over GNI as a U.S. dollar has in the United States. GNI is the sum of value added by all resident producers plus any product taxes (less subsidies) not included in the valuation of output plus net receipts of primary income (compensation of employees and property income) from abroad. Data are in current international dollars. This indicator is commonly used to evaluate the status of wealth sustainability on national level.

⁽⁴⁶⁾ *Poverty* (percent of population headcount ratio at or below national poverty line): National poverty rate is the percentage of the population living below the national poverty line. National estimates are based on population-weighted subgroup estimates from household surveys.

RESPONSE(WEALTH)

⁽⁴⁷⁾ *Exports of goods and services* (percent of GDP): Exports of goods and services represent the value of all goods and other market services provided to the rest of the world. Exports create wealth.

⁽⁴⁸⁾ *Foreign direct investment, net inflows* (percent of GDP): Foreign direct investment is net inflows of investment to acquire a lasting management interest (10 percent or more of voting stock) in an enterprise operating in an economy other than that of the investor.

G. HEALTH Indicators

PRESSURE(HEALTH)

⁽⁴⁹⁾ *Infant mortality rate*: Number of infants who die before reaching one year of age, expressed per thousand live births in a given year.

⁽⁵⁰⁾ *Maternal mortality rate*: Annual number of deaths from pregnancy or childbirth related causes per 100,000 live births. A maternal death is defined by WHO as the death of woman while pregnant or within 42 days of the termination of pregnancy from any cause related to or aggravated by the pregnancy, including abortion.

⁽⁵¹⁾ *HIV/AIDS prevalence* (percent of population aged 15–49): Prevalence of HIV refers to the percentage of people ages 15–49 who are infected with HIV.

⁽⁵²⁾ *Tuberculosis (TB) prevalence* (per 100,000 population). It refers to people with all forms of TB, including TB in people with HIV infection.

⁽⁵³⁾ *Number of confirmed polio cases*: Suspected polio cases that are confirmed by laboratory examination or are consistent with polio infection.

⁽⁵⁴⁾ *Standardized reported malaria cases per 1000*: Standardized cases are derived from the total reported number of cases

and an appreciation of the proportion of these cases that were laboratory-confirmed. Reported cases per country for the most recent year for which WHO/RBM received data. The standardized case reporting rate (per 1000 per year) is calculated by dividing the standardized cases by the national population size estimated by the United Nations Population Division for the middle of the year under consideration.

⁽⁵⁵⁾ *Solid fuel household use*: The use of solid fuels in households is associated with increased mortality from pneumonia and other acute lower respiratory diseases among children as well as increased mortality from chronic obstructive pulmonary disease and lung cancer (where coal is used) among adults. It is also a Millennium Development Goal indicator. National energy statistics on the proportion of population using solid fuels are based either on data from surveys or censuses, or on modeling where no survey or census data are available.

STATE(HEALTH)

⁽⁵⁶⁾ *Life expectancy*: Number of years a newborn infant would live if patterns of mortality prevailing at the time of its birth were to stay the same throughout its life. Life expectancy reflects the sustainability of a health system.

^(57, 58) *Infants immunized against severe diseases*: Percent of one-year-old infants immunized against measles⁵⁷ and diphtheria-pertussis-tetanus (DPT)⁵⁸.

⁽⁵⁹⁾ *Daily per capita calorie supply* (percent of total requirements): Data taken from the Food and Agricultural Organization (FAO) food balance sheets. The calories and protein actually consumed may be lower than the figure shown, depending on how much is lost during home storage, preparation, and cooking, and how much is fed to pets and domestic animals or discarded.

RESPONSE(HEALTH)

⁽⁶⁰⁾ *Number of doctors* (per thousand people): The term doctors includes physicians that are defined as graduates of any faculty or school of medicine who are working in the country in any medical field (practice, teaching, research).

⁽⁶¹⁾ *Hospital beds* (per thousand people): Hospital beds include inpatient beds available in public, private, general, and specialized hospitals and rehabilitation centers. In most cases beds for both acute and chronic care are included.

⁽⁶²⁾ *Public health expenditure* (percent of GDP): Consists of recurrent and capital spending from government budgets, external borrowings and grants, and social health insurance funds.

^(63, 64) *Access to improved water sources*⁶³ and to *improved sanitation*⁶⁴ (percent of population): The percentage of population with access to the facilities that can provide them safe water and sanitation. Access to the above is a fundamental need and a human right vital for the dignity and health of all people.

H. KNOWLEDGE indicators

PRESSURE(KNOW)

⁽⁶⁵⁻⁶⁷⁾ *Ratio of students to teaching staff* (primary⁶⁵, secondary⁶⁶, and tertiary⁶⁷ education): Teaching staff includes [16] professional personnel involved in direct student instruction: classroom teachers, special education teachers, other teachers who work with students as a whole class, chairpersons of departments; it does not include nonprofessional personnel who support teachers.

STATE(KNOW)

^(68, 69) *Expected years of schooling*; male⁶⁸ and female⁶⁹: Average number of years of formal schooling that a child is expected to receive, including university education and years spent in repetition. It may also be interpreted as an indicator of the total educational resources, measured in school years, a child will require over the course of schooling.

^(70, 71) *Net school enrollment ratio*; primary⁷⁰ and secondary⁷¹: Number of children of official school age, as defined by the education system, enrolled in primary or secondary school, expressed as percentage of the total number of children of that age.

⁽⁷²⁾ *Literacy rate*, adult total (percent of people with ages 15 and above): Adult literacy rate is the percentage of people ages 15 and above who can, with understanding, read and write a short, simple statement on their everyday life.

⁽⁷³⁾ *World Bank's Knowledge Economy Index (KEI)* [24]: KEI takes into account whether the environment is conducive for knowledge to be used effectively for economic development. It is an aggregate index that represents the overall level of development of a country or region towards the Knowledge Economy.

RESPONSE(KNOW)

⁽⁷⁴⁾ *Public expenditure on R&D* (percent of GDP): Expenditures for research and development are current and capital expenditures (both public and private) on creative, systematic activity that increases the stock of knowledge. Included are fundamental and applied research and experimental development work leading to new devices, products, or processes.

⁽⁷⁵⁾ *Public expenditure on education*: Percentage of GNP accounted for by public spending on public education plus subsidies to private education at the primary, secondary, and tertiary levels. It may exclude spending by religious schools, which play a significant role in many developing countries. Data for some countries and for some years refer to spending by the ministry of education of the central government only, and thus exclude education expenditures by other central government ministries and departments, local authorities, and others.

⁽⁷⁶⁾ *Personal computers* (per thousand people): Estimated numbers of self-contained computers used by a single person. Access to personal computers promotes knowledge development and educational sustainability.

⁽⁷⁷⁾ *Internet users* (per thousand people): Number of computers directly connected to the worldwide network of interconnected computer systems, per 10,000 people. Access to the Internet facilitates knowledge acquisition.

(78) *Information and communication technology expenditure* (percent of GDP): Information and communications technology expenditures include computer hardware (computers, storage devices, printers, and other peripherals); computer software (operating systems, programming tools, utilities, applications, and internal software development); computer services (information technology consulting, computer and network systems integration, web hosting, data processing services, and other services); and communications services (voice and data communications services) and wired and wireless communications equipment.

APPENDIX B
SELECTED RULE BASES

Tables VI and VII describe some typical rule bases of the model.

TABLE VI
RULES FOR COMPUTING THE OVERALL SUSTAINABILITY

Rule R_p	if ECOS is	and HUMS is	then OSUS is	Rule R_p	if ECOS is	and HUMS is	then OSUS is
R_1	VB	VB	EL	R_{14}	A	G	FH
R_2	VB	B	VL	R_{15}	A	VG	H
R_3	VB	A	L	R_{16}	G	VB	FL
R_4	VB	G	FL	R_{17}	G	B	I
R_5	VB	VG	I	R_{18}	G	A	FH
R_6	B	VB	VL	R_{19}	G	G	H
R_7	B	B	L	R_{20}	G	VG	VH
R_8	B	A	FL	R_{21}	VG	VB	I
R_9	B	G	I	R_{22}	VG	B	FH
R_{10}	B	VG	FH	R_{23}	VG	A	H
R_{11}	A	VB	L	R_{24}	VG	G	VH
R_{12}	A	B	FL	R_{25}	VG	VG	EH
R_{13}	A	A	I				

TABLE VII
RULES WITH FOUR BASIC INPUTS

Rule R_p	if x_{26} is	and x_{27} is	and x_{28} is	and x_{29} is	then STATE(AIR) is	Rule R_p	if x_{26} is	and x_{27} is	and x_{28} is	and x_{29} is	then STATE(AIR) is
R_1	W	W	W	W	VB	R_{42}	M	M	M	S	G
R_2	W	W	W	M	VB	R_{43}	M	M	S	W	A
R_3	W	W	W	S	VB	R_{44}	M	M	S	M	G
R_4	W	W	M	W	VB	R_{45}	M	M	S	S	VG
R_5	W	W	M	M	VB	R_{46}	M	S	W	W	B
R_6	W	W	M	S	B	R_{47}	M	S	W	M	A
R_7	W	W	S	W	VB	R_{48}	M	S	W	S	G
R_8	W	W	S	M	B	R_{49}	M	S	M	W	A
R_9	W	W	S	S	A	R_{50}	M	S	M	M	G
R_{10}	W	M	W	W	VB	R_{51}	M	S	M	S	VG
R_{11}	W	M	W	M	VB	R_{52}	M	S	S	W	G
R_{12}	W	M	W	S	B	R_{53}	M	S	S	M	VG
R_{13}	W	M	M	W	VB	R_{54}	M	S	S	S	VG
R_{14}	W	M	M	M	B	R_{55}	S	W	W	W	VB
R_{15}	W	M	M	S	A	R_{56}	S	W	W	M	B
R_{16}	W	M	S	W	B	R_{57}	S	W	W	S	A
R_{17}	W	M	S	M	A	R_{58}	S	W	M	W	B
R_{18}	W	M	S	S	G	R_{59}	S	W	M	M	A
R_{19}	W	S	W	W	VB	R_{60}	S	W	M	S	G
R_{20}	W	S	W	M	B	R_{61}	S	W	S	W	A
R_{21}	W	S	W	S	A	R_{62}	S	W	S	M	G
R_{22}	W	S	M	W	B	R_{63}	S	W	S	S	VG
R_{23}	W	S	M	M	A	R_{64}	S	M	W	W	B
R_{24}	W	S	M	S	G	R_{65}	S	M	W	M	A
R_{25}	W	S	S	W	A	R_{66}	S	M	W	S	G
R_{26}	W	S	S	M	G	R_{67}	S	M	M	W	A
R_{27}	W	S	S	S	VG	R_{68}	S	M	M	M	G
R_{28}	M	W	W	W	VB	R_{69}	S	M	M	S	VG
R_{29}	M	W	W	M	VB	R_{70}	S	M	S	W	G
R_{30}	M	W	W	S	B	R_{71}	S	M	S	M	VG
R_{31}	M	W	M	W	VB	R_{72}	S	M	S	S	VG
R_{32}	M	W	M	M	B	R_{73}	S	S	W	W	A
R_{33}	M	W	M	S	A	R_{74}	S	S	W	M	G
R_{34}	M	W	S	W	B	R_{75}	S	S	W	S	VG
R_{35}	M	W	S	M	A	R_{76}	S	S	M	W	G
R_{36}	M	W	S	S	G	R_{77}	S	S	M	M	VG
R_{37}	M	M	W	W	VB	R_{78}	S	S	M	S	VG
R_{38}	M	M	W	M	B	R_{79}	S	S	S	W	VG
R_{39}	M	M	W	S	A	R_{80}	S	S	S	M	VG
R_{40}	M	M	M	W	B	R_{81}	S	S	S	S	VG
R_{41}	M	M	M	M	A						

REFERENCES

- [1] Y. A. Phillis and L. A. Andriantiatsaholiniaina, "Sustainability: an ill-defined concept and its assessment using fuzzy logic," *Ecol. Econ.*, vol. 37, no. 3, pp. 435–456, 2001.
- [2] L.A. Andriantiatsaholiniaina, V.S. Kouikoglou, and Y.A. Phillis, "Evaluating strategies for sustainable development: Fuzzy logic reasoning and sensitivity analysis," *Ecol. Econ.*, vol. 48, no. 2, pp. 149–172, 2004.
- [3] J. M. Won, S. Y. Park, and J. S. Lee, "Parameter conditions for monotonic Takagi-Sugeno-Kang fuzzy system," *Fuzzy Set. Syst.*, vol. 132, no. 2, pp. 135–146, 2002.

- [4] V. S. Kouikoglou and Y. A. Phillis, "A monotonic hierarchical fuzzy system with sum-product logic," working paper.
- [5] D. C. Esty, M. Levy, T. Srebotnjak, and A. Sherbinin, *2005 Environmental Sustainability Index: Benchmarking National Environmental Stewardship*, New Haven, CT, Yale Center for Environmental Law & Policy, 2005. Available: <http://www.yale.edu/esi>.
- [6] T. Takagi and M. Sugeno, "Fuzzy identification of systems and its applications," *IEEE Trans. Systems Man Cybernet.*, vol. 15, no. 1, pp. 116–132, 1985.
- [7] M. Sugeno and G. T. Kang, "Structure identification of fuzzy model," *Fuzzy Set. Syst.*, vol. 28, pp. 15–33, 1988.
- [8] OECD (Organization of Economic Cooperation and Development), *Key Environmental Indicators 2004*, OECD, Paris, 2004. Available: <http://www.oecd.org/dataoecd/32/20/31558547.pdf>.
- [9] J. D. Hamilton, *Time Series Analysis*, Princeton Univ. Press, Princeton, NJ, 1994, pp. 440–443.
- [10] W. G. Gilchrist, "Methods of estimation using discounting," *J. Royal Stat. Soc. (B)*, vol. 29, 355–369, 1967.
- [11] S. M. H. Ordoubadi, *World Development Indicators*, The World Bank Development Data Center, 2005.
- [12] FAO (Food and Agricultural Organization). Available: <http://www.fao.org>.
- [13] United Nations Development Program (UNDP), *Human Development Report 2003*, Oxford University Press, New York 2003.
- [14] World Bank, "Monitoring environmental progress: A report on work in progress," World Bank Environmentally Sustainable Development International Bank for Reconstruction and Development, Washington, DC, 1995.
- [15] OECD (Organization of Economic Cooperation and Development). Available: <http://www.oecd.org>.
- [16] OECD, *Education at a Glance*, OECD Publications, Paris, 2000.
- [17] The World Conservation Union. Available: <http://www.iucn.org>
- [18] UNEP (United Nations Environmental Program).
- [19] United Nations Statistics Division, "Population and vital statistics report." Available: <http://unstats.un.org/unsd/seriesa/354.asp>.
- [20] UNESCO (United Nations Educational, Scientific, and Cultural Organization), Institute for Statistics.
- [21] WHO (World Health Organization). Available: <http://www.who.int/en>
- [22] The Freedom House Annual Survey. Available: <http://www.worldaudit.org>.
- [23] IUCN (International Union for Conservation of Nature), *Guidelines for Protected Areas Management Categories*, IUCN, Cambridge, UK and Gland, Switzerland, 1994.
- [24] World Bank. KI and KEI Indexes. [Online]. Available: <http://www.worldbank.org/wbi/>.



Yannis A. Phillis (S'78–M'80–SM'83) received the Diploma in Electrical and Mechanical engineering from the National Technical University of Athens, Greece, in 1973 and M.S. and Ph.D. degrees from the University of California, Los Angeles, in 1978 and 1980, respectively.

From 1980 to 1986, he was a faculty member at Boston University, Boston, MA. Since 1986, he has been with the Department of Production Engineering and Management, Technical University of Crete, Chania, Greece where he is Professor and Director of the CAM Laboratory. He was Rector of the Technical University of Crete for ten years. His research interests are in stochastic control, discrete-event systems, and applications in manufacturing networks and environmental systems.

Dr. Phillis is a Fellow of the AAAS. He received the Professor of the Year Award at Boston University in 1986 and an award by the Academy of Athens, Greece, in 2007 for creating the Park for the Preservation of Flora and Fauna at the Technical University of Crete. He was Chairman of the Fifth International Conference on Advances in Communication and Control (1995) and the International Conference on Management of Technological Change (2003, 2005). He is an award winning writer in Greece. He was on the Editorial Board of the *Encyclopedia of Life Support Systems* and the *IEEE Robotics and Automation Magazine*. Currently he is an Editor of the *Journal of Intelligent and Robotic Systems* and the *Environmental Engineering and Management Journal*, an Associate Editor of the *International Journal of Engineering Management*, and a member of the Editorial Board of *IEEE Systems Journal*.



Victor Kouloumpis received the diploma and the Ph.D. degree in production engineering and management and the M.S. degree in quality control and environmental management from the Technical University of Crete, Chania, Greece, in 2002, 2007, and 2004, respectively.

Currently, he is a research scientist with the Laboratory of Renewable and Sustainable Energy, Department of Environmental Engineering, Technical University of Crete. His research interests are in sustainable development and renewable energy sources.



Vassilis S. Kouikoglou (S'88–M'91–SM'99) received the diploma in electrical engineering from the National Technical University of Athens, Athens, Greece, in 1985 and the Ph.D. degree in production engineering and management from the Technical University of Crete, Chania, Greece, in 1989.

Since 1991, he has been with the Department of Production Engineering and Management, Technical University of Crete, Chania, Crete, where he is a professor and has served as chairman. His research interests are in modeling and optimization of production networks.