



AALBORG UNIVERSITY
DENMARK

Aalborg Universitet

SVD-based vs. Release 8 codebooks for Single User MIMO LTE-A Uplink

Berardinelli, Gilberto; Sørensen, Troels Bundgaard; Mogensen, Preben; Pajukoski, Kari

Published in:
I E E E V T S Vehicular Technology Conference. Proceedings

DOI (link to publication from Publisher):
[10.1109/VETECS.2010.5493709](https://doi.org/10.1109/VETECS.2010.5493709)

Publication date:
2010

Document Version
Early version, also known as pre-print

[Link to publication from Aalborg University](#)

Citation for published version (APA):
Berardinelli, G., Sørensen, T. B., Mogensen, P., & Pajukoski, K. (2010). SVD-based vs. Release 8 codebooks for Single User MIMO LTE-A Uplink. *I E E E V T S Vehicular Technology Conference. Proceedings*.
<https://doi.org/10.1109/VETECS.2010.5493709>

General rights

Copyright and moral rights for the publications made accessible in the public portal are retained by the authors and/or other copyright owners and it is a condition of accessing publications that users recognise and abide by the legal requirements associated with these rights.

- Users may download and print one copy of any publication from the public portal for the purpose of private study or research.
- You may not further distribute the material or use it for any profit-making activity or commercial gain
- You may freely distribute the URL identifying the publication in the public portal -

Take down policy

If you believe that this document breaches copyright please contact us at vbn@aub.aau.dk providing details, and we will remove access to the work immediately and investigate your claim.

SVD-based vs. Release 8 codebooks for Single User MIMO LTE-A Uplink

Gilberto Berardinelli ⁽¹⁾, Troels B.Sørensen ⁽¹⁾, Preben Mogensen ⁽¹⁾, Kari Pajukoski ⁽²⁾

⁽¹⁾ Department of Electronic Systems, Aalborg University, Denmark
Email: gb@es.aau.dk

⁽²⁾ Nokia-Siemens Networks, Oulu, Finland

Abstract—The ambitious data rate target of the Long Term Evolution - Advanced (LTE-A) systems, which are currently being standardized by the 3rd Generation Partnership Project (3GPP), can only be achieved by using advanced Multiple Input Multiple Output (MIMO) antenna techniques on both uplink and downlink. In this paper, the focus is on LTE-A uplink and we discuss the suitability of two options for the closed loop precoded MIMO transmission. The first option is to use the same codebook of precoding matrices defined for LTE downlink, while the second option exploits the Singular Value Decomposition (SVD) of the channel matrix, which could theoretically achieve the MIMO capacity. Qualitative benefits of both solutions are discussed. Link level simulation results show that, the SVD-based approach only lead to a poor performance gain in terms of spectral efficiency over the LTE downlink codebook because of the losses due to the quantization of the right singular vectors of the channel matrix. Since SVD-based solution does not even exploit some useful properties (e.g., power balance over the antennas) which LTE Release 8 codebook offers, the latter results to be a more suitable candidate for the closed loop MIMO transmission in LTE-A uplink.

Index Terms—LTE-A, MIMO, precoding, SC-FDM, MMSE, Release 8, SVD

I. INTRODUCTION

The system requirements of the Long-Term Evolution Advanced (LTE-A) systems are currently being specified by the 3rd Generation Partnership Project (3GPP) [1]. LTE-A aims at peak data rates of 1 Gbit/s for the downlink and 500 Mbit/s for the uplink, which can be accomplished only by using wide spectrum allocation of 100 MHz and more as well as advanced Multiple Input Multiple Output (MIMO) antenna techniques. Further features as channel dependent scheduling, link adaptation and adaptive transmission bandwidth are also required to boost the system performance.

In the previous LTE Release 8 [2], Orthogonal Frequency Division Multiplexing (OFDM) was selected as modulation scheme for the downlink due to its flexibility as well as its robustness to the multipath [3], and Single Carrier Frequency Division Multiplexing (SC-FDM) for the uplink because of its advantageous low Peak-To-Average Power Ratio (PAPR) property [4]. This choice has been recently confirmed also for LTE-A [5].

While in LTE Release 8 MIMO solutions have been standardized only for the downlink, in LTE-A they are expected

to take place even for the uplink to achieve the ambitious data rate target. In most of the MIMO applications the channel state information (CSI) at the receiver is needed to perform the equalization task; furthermore, it is known that some degrees of channel knowledge on the transmitter side can further boost the system performance through a channel-aware precoding operation of the data streams. For this purpose, LTE Release 8 defined for the MIMO downlink transmission a codebook of precoding matrices [2] to be selected using criteria related to the instantaneous state of the channel. The LTE codebook was designed by selecting matrices having 8PSK entries and coping with a large range of propagation conditions, at the same time keeping large chordal distance [6]. On the other side, it is well known from literature (e.g., [7]) that the MIMO capacity with full channel knowledge at the transmitter can be achieved by exploiting the Singular Value Decomposition (SVD) of the channel matrix, which allows to send data over the strongest eigenmodes of the channel. However, in a system where the channel knowledge at the transmitter side is obtained through feedback messages, a codebook has to be designed to quantize the right singular vectors obtained with SVD operation (e.g., [8], [9]).

In this paper, both the Release 8 and the SVD-based codebook are evaluated in a Single User MIMO Uplink LTE-A system, and their performance is compared. Advantages and disadvantages of both solutions are widely discussed. Our aim is obtaining useful insights on the feasibility of the precoding solutions for the upcoming standard.

The remainder of the paper is structured as follows. In Section II the system model is presented. Section III discusses both LTE and SVD-based codebook as well as the criteria for the selection of the precoding matrix. In Section IV the simulation results are presented and discussed. Finally, Section V resumes the conclusions and states the future work.

II. SYSTEM MODEL

A simplified baseband model of a MIMO SC-FDM transceiver chain with 2 codewords (CWs), N_T transmit antennas and N_R receive antennas is depicted in Fig.1. Note that a system with 2 CWs for the uplink is commonly assumed within 3GPP [2]. For each CW, the information bits are independently encoded, interleaved, and finally mapped to

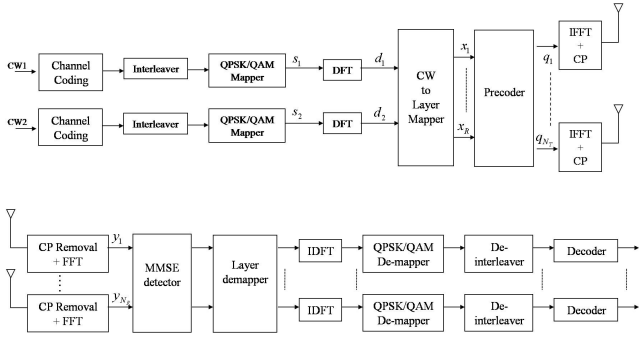

Fig. 1. Simplified SC-FDM block diagram.

QPSK/M-QAM symbols, yielding the vectors \mathbf{s}_i , $i=1,2$. The amount of data to be encoded for each CW depends on the transmission rank and the selected modulation and coding scheme (MCS). Then, a Discrete Fourier Transform (DFT) is performed, spreading each data symbol over all the subcarriers, obtaining the vectors \mathbf{d}_i . The complex symbols \mathbf{d}_i are fed to the CW-to-layer mapper, which splits the data over R layers, where R is the rank of the transmission, and afterwards to the precoder block. The output of the precoder for each subcarrier k can be expressed as:

$$\mathbf{q}[k] = \mathbf{F}[k]\mathbf{x}[k] \quad (1)$$

where $\mathbf{x}[k] = [x_1(k), x_2(k), \dots, x_R(k)]^T$ is a vector containing the encoded MIMO complex transmit symbols at subcarrier k , and $\mathbf{F}[k]$ is a $N_T \times R$ complex precoding matrix.

Finally, an Inverse Fast Fourier Transform (IFFT) is applied and a Cyclic Prefix (CP) is appended. Assuming that the channel response is static over the duration of a SC-FDM symbol, and the CP is long enough to cope with the maximum excess delay of the channel [3], the received signal after CP removal and fast Fourier transform (FFT) can be written as follows:

$$\mathbf{y}[k] = \mathbf{H}[k]\mathbf{q}[k] + \mathbf{w}[k] \quad (2)$$

where $\mathbf{w}[k] = [w_1(k), w_2(k), \dots, w_{N_R}(k)]^T$ is the additive white Gaussian noise (AWGN) vector with $E[w_i(k)w_i(k)^*] = \sigma_w^2$ and

$$\mathbf{H}[k] = \begin{bmatrix} h_{11}(k) & \dots & h_{1N_T}(k) \\ \vdots & \ddots & \vdots \\ h_{N_R1}(k) & \dots & h_{N_RN_T}(k) \end{bmatrix} \quad (3)$$

is the channel transfer function matrix at subcarrier k . $h_{ij}(k)$ denotes the complex channel gain from the transmit antenna j to the receive antenna i . In this study, it is assumed that $E[s_i(k)s_i(k)^*] = 1$ and that the transmitted power is equally distributed among the transmit antennas.

The signal \mathbf{y} is then fed to the Minimum Mean Square Error (MMSE) detector [10], which compensates the amplitude and phase distortion introduced by the channel and reduces the interstream interference. Assuming perfect channel knowledge, the output of the MMSE detector in subcarrier k can be written as follows:

$$\mathbf{y}_{\text{eq}}[k] = (\mathbf{F}[k]^H \mathbf{H}[k]^H \mathbf{H}[k] \mathbf{F}[k] + \sigma_w^2 \mathbf{I}_R)^{-1} \mathbf{F}[k]^H \mathbf{H}[k]^H \mathbf{y}[k] \quad (4)$$

where \mathbf{I}_R is the $R \times R$ identity matrix. The rest of the receiver chain performs the reverse operations of the transmitter side. Note that, in a SC-FDM system, an estimate of the data symbol is obtained after the Inverse Discrete Fourier Transform (IDFT) operation.

III. RELEASE 8 VS. SVD-BASED CODEBOOKS

As mentioned above, the aim of the precoding is to enhance the link reliability by exploiting the channel knowledge at the transmitter. In a Frequency Division Duplex (FDD) system, where Base Station (BS) and User Equipment (UE) operate over different bands, the channel knowledge is however limited and can only be achieved through feedback signaling: in our UL model, a precoding matrix belonging to a predefined codebook should be selected in the BS and its index fed back to the UE. In this section, the principles of the Release 8 codebook and the SVD-based codebook are presented. A qualitative discussion on the benefits and the drawbacks of both solutions is also included.

A. Release 8 codebooks

For the OFDM MIMO downlink transmission, Release 8 defined codebooks for 2 and 4 transmit antennas (2Tx, 4Tx) [2].

For 2Tx case, a set of 6 vectors with dimension 2×1 and large chordal distance (1.4142) has been defined for rank 1 transmission. The codebook for rank 2 transmission is obtained by permuting the couples of vectors of the codebook for rank 1 transmission which keep the unitary property of the precoding matrix. However, in the work item (WI) for LTE-A it has been recently agreed to remove the codebook for rank 2 transmission and replace it with the identity matrix \mathbf{I}_2 . This is because closed loop transmission with full rank has been shown not to provide significant gain over the open loop (OL) one.

The codebooks for 4Tx transmission are obtained by permuting the columns of the 4×4 Householder matrix. The codebook for each rank R , with $R = 1, 2, 3, 4$ consists of 16 $4 \times R$ precoding matrices. The bigger size of 4Tx codebook compared to the 2Tx one allows to cope with a wider range of propagation conditions (e.g., single and double polarized antenna pattern) which the 4Tx transmission offers. This codebook has also been shown to fulfill the requirements of large chordal distance (0.7071, 1 and 0.7071 for rank 1, 2 and 3, respectively). Again, it has been recently decided to replace the rank 4 codebook with the identity matrix \mathbf{I}_4 .

The selection of the precoding matrix is usually based on a post-detection criterion. Defining the following post-MMSE channel power matrix in subcarrier k :

$$\mathbf{M}_{\mathbf{F}_i}[k] = (\mathbf{H}_{\text{eq}}^H[k] \mathbf{H}_{\text{eq}}[k] + \sigma_n^2 \mathbf{I}_R)^{-1} \mathbf{H}_{\text{eq}}^H[k] \mathbf{H}_{\text{eq}}[k] \quad (5)$$

where $\mathbf{H}_{\text{eq}}[k] = \mathbf{F}_i[k]\mathbf{H}[k]$, the selection criterion can be expressed as follows:

Select

$$\mathbf{F}_s = \arg \max_{\mathbf{F}_i \in C} \sum_{j=1}^R \frac{m_{F_i[k]}(j)}{1 - m_{F_i[k]}(j)} \cdot \sigma_n^2 \quad (6)$$

where $m_{F_i[k]} = \text{diag}(\mathbf{M}_{F_i}[k])$, and C is the Release 8 codebook for rank R . It can be easily shown that the expression in Eq.(6) corresponds to the sum of the equivalent channel gains for the R layers.

Since it may be impractical sending a feedback message for each subcarrier, the selection of the codebook element is generally done over a group of N_s subcarriers, i.e.

Select

$$\mathbf{F}_s = \arg \max_{\mathbf{F}_i \in C} \frac{1}{N_s} \sum_{k=1}^{N_s} \sum_{j=1}^R \frac{m_{F_i[k]}(j)}{1 - m_{F_i[k]}(j)} \cdot \sigma_n^2 \quad (7)$$

In the following, we will refer to wideband (WB) precoding when the precoding matrix is selected over the whole transmission bandwidth.

The main advantages of the Release 8 codebooks can be summarized as follows:

- *Complexity reduction.* All the elements in the matrices belong to the set $\{\pm 1, \pm j, \frac{\pm 1 \pm j}{2}\}$. It can be shown [11] that this property reduces the number of matrix-vector operations for the MMSE metric computation.
- *Nested property.* The lower rank precoder is part of the precoder used for larger rank. This allows to re-use the calculation of the lower rank precoder for the larger rank in case of rank overriding.
- *Constant modulus property.* Release 8 codebooks preserve the same average power over all the antennas. This avoids the power imbalance which is undesirable in the transmitter [6]. Note that this property is only broken by two vectors in the 2Tx rank 1 codebook.

B. SVD-based codebooks

The well-known solution in literature for exploiting the channel knowledge at the transmitter is to send data over the strongest eigenmodes of the channel. A common way to express the channel matrix in subcarrier k is through its Singular Value Decomposition (SVD) [12], as follows:

$$\mathbf{H}[k] = \mathbf{U}[k]\mathbf{\Sigma}[k]\mathbf{V}[k]^H \quad (8)$$

where $\mathbf{\Sigma}[k]$ is a $N_R \times N_T$ matrix having in its diagonal the eigenvalues of $\mathbf{H}[k]^H\mathbf{H}[k]$ (i.e., $\mathbf{\Sigma}[k] = \text{diag}(\lambda_1, \dots, \lambda_{N_R})$), $\mathbf{U}[k]$ is the $N_R \times N_R$ unitary matrix having as columns the eigenvectors of $\mathbf{H}[k]^H\mathbf{H}[k]$, $\mathbf{V}[k]$ is the $N_T \times N_T$ unitary matrix having as columns the eigenvectors of $\mathbf{H}[k]\mathbf{H}[k]^H$. Let us define now the following precoding matrix:

$$\mathbf{F}[k] = \mathbf{V}[k] \quad (9)$$

It can be easily shown that, if the $\mathbf{U}[k]^H$ matrix is used as a matched filter at the receiver, the MIMO channel can

be decomposed in N_T Single-Input-Single-Output (SISO) channels, even called eigenmodes, whose gains are given by $\lambda_1^2, \dots, \lambda_{N_T}^2$. This allows to increase the capacity of the MIMO system, since the interstream interference is *a priori* removed. The MIMO capacity can be achieved by dividing the power among the antennas according to the waterfilling algorithm [7]; however, this solution is not advantageous in a practical system because of the limited MCS set [13].

The SVD-based codebook is obtained from the quantization of the $\mathbf{V}[k]$ matrix. In [14], an efficient method for the derivation of a codebook of unitary matrices based on the iterative Lloyd Algorithm [15] is proposed. In this way, it is possible to select as a precoder the unitary matrix belonging to the codebook which is closer to the $\mathbf{V}[k]$ matrix. The following selection criterion is adopted:

Select

$$\mathbf{F}_s = \arg \min_{\hat{\mathbf{F}}_i \in C} \left\| \mathbf{V}[k]\mathbf{D}[k] - \hat{\mathbf{F}}_i \right\|_F \quad (10)$$

where C is the codebook of unitary matrices, $\|\cdot\|$ denotes the Frobenius norm, and \mathbf{D} is defined as:

$$\mathbf{D}[k] = \text{diag}(-\phi) \quad (11)$$

where ϕ is the phase vector of $\hat{\mathbf{F}}_{i,j}[k]\mathbf{V}_j[k]$, with $\hat{\mathbf{F}}_{i,j}$ and \mathbf{V}_j denoting the j -th column of the $\hat{\mathbf{F}}_i$ and the \mathbf{V} matrices. The matrix $\mathbf{D}[k]$ resolves the ambiguity of the non-univocity of the SVD decomposition [12].

Again, to reduce the feedback overhead the selection of the precoding matrix is generally done over a set of N_s subcarriers, i.e.

Select

$$\mathbf{F}_s = \arg \min_{\hat{\mathbf{F}}_i \in C} \frac{1}{N_s} \sum_{k=1}^{N_s} \left\| \mathbf{V}[k]\mathbf{D}[k] - \hat{\mathbf{F}}_i \right\|_F \quad (12)$$

In the SVD-based codebook, the entries of the matrices are random-like, and this would lead to an increase of the computational complexity for the selection of the precoding matrix. Furthermore, the nested property is not exploited, since an independent codebook should be derived for each of the ranks. It can be even shown that a codebook based on SVD introduces power imbalance among the antennas for rank $R < N_T$. The main advantage of the SVD-based approach for the codebook generation is its simple scalability; codebooks of larger size can be easily obtained with the Lloyd Algorithm by performing a more accurate quantization of the \mathbf{V} matrix.

IV. PERFORMANCE EVALUATION

The performance of the discussed codebooks are evaluated by using an LTE-compliant link level simulator. We use as a reference 10 MHz LTE configuration parameters [2], which are gathered in Table I. An urban micro channel model (SCM-D) [1] with a coherence bandwidth of around 1 MHz is used in the simulations, and low mobility (3 kmph) is assumed. Results are obtained by using Fast Link adaptation (i.e., adaptive modulation and coding scheme) [16]: the selected MCS for each of the CW is the one leading to higher expected

TABLE I
SIMULATION PARAMETERS

Carrier frequency	2 GHz
Sampling frequency	15.36 MHz
Subcarrier spacing	15 KHz
FFT size	1024
Used subcarriers	600
CP length	$5.2^a/4.68^b \mu s$
Slot duration	0.5 ms
Symbols per slot	7
Antenna configurations	1x2, 2x2, 1x4, 2x4, 3x4, 4x4
Pilot Overhead (Op)	0
Transmission ranks	1,2,3
User speed	3 kmph
MCS settings	QPSK: 1/6, 1/3, 1/2, 2/3 16QAM: 1/2, 2/3, 3/4 64QAM: 2/3, 4/5
Channel code	3GPP Rel.8 compliant Turbo code
Turbo decoder iterations	8
BLER target for Fast LA	10%

^aFirst OFDM/SC-FDM symbol in a slot.

^b $2^{th} - 7^{th}$ OFDM/SC-FDM symbol in a slot.

throughput given a certain Block Error Rate (BLER) target (typically, 10 per cent in LTE), and its index is fed back to the UE through signalling. Furthermore, we consider perfect channel knowledge at the receiver and error-free feedback transmission for the indexes of the MCSs and the precoding matrix. A 5 ms delay, corresponding to 10 transmission slots, is assumed between the selection of the precoding matrix and the MCS in the receiver, and their application in the transmitter.

In the simulations WB precoding is assumed since it has been shown to preserve the low PAPR property of the SC-FDM signal [16]. Furthermore, WB precoding allows to keep a reasonably low feedback overhead.

In Fig.2, the performance of SVD-based and Release 8 codebooks is shown in terms of spectral efficiency assuming a 2x2 antenna system and rank 1 transmission. Unquantized SVD as well as OL 1x2 curves are also included. In order to ensure a fair comparison, an SVD codebook requiring the same feedback overhead (FO) of the Rel.8 codebook (in this case, 3 bits per time slot) is generated. Note that unquantized SVD approach leads to a gain up to 5 dB over OL 1x2. This is because unquantized SVD approach allows to transmit over the strongest eigenmode of the channel. However, no spectral efficiency gain is noticeable over Rel.8 codebook for the quantized SVD approach requiring the same feedback overhead. Furthermore, a codebook of 256 matrices (i.e., 8 bits of feedback overhead) shows only a small gain with respect to the codebook containing 2^3 matrices. Even though the SVD decomposition would lead to an impressive gain over OL transmission, the necessity of quantizing the right singular vector of the channel to send it as a feedback message leads

to a consistent loss which makes its performance similar to the one of Rel.8 codebook.

In Fig.3, the performance of the codebooks is evaluated in a 4x4 antenna system assuming rank 1 transmission. The Rel.8 result for 2x2 antenna configuration is also included at the purpose of comparison. The behaviour of the codebooks is similar to the 2x2 case: Rel.8 codebook performs as good as SVD codebook when the same feedback overhead is assumed (4 bits per time slot), and an extended codebook of 256 matrices only leads to a small improvement. Note that 4x4 allows to leverage the performance with respect to 2x2 because of the increase of the diversity branches.

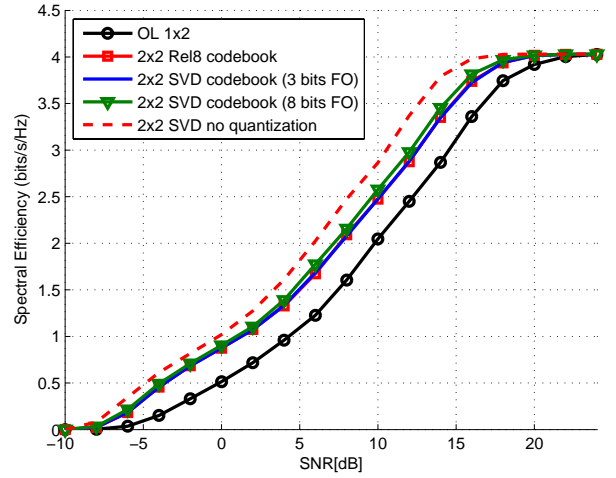

Fig. 2. Spectral efficiency performance for rank 1 transmission and 2x2 antenna configuration.

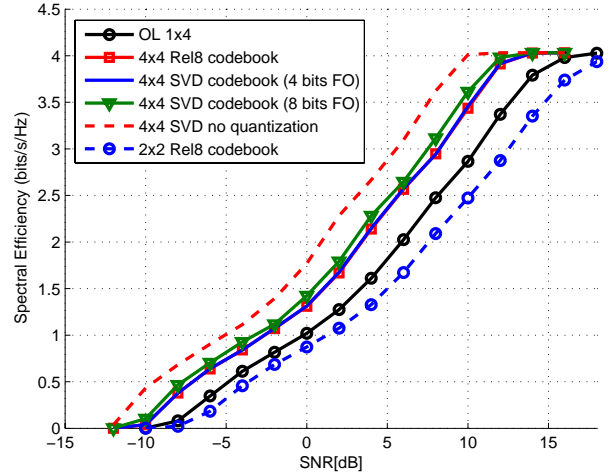

Fig. 3. Spectral efficiency performance for rank 1 transmission and 4x4 antenna configuration.

Results for 4x4 and rank 2 transmission are shown in Fig.4. In this case closed loop transmission with Rel.8 codebook only leads to a gain of around 1 dB over OL 2x4. This

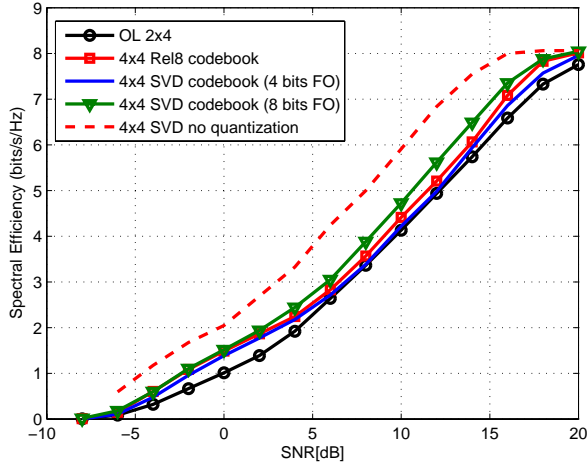

Fig. 4. Spectral efficiency performance for rank 2 transmission and 4x4 antenna configuration.

is because the diversity gain obtained with transmission of 2 streams over 4 antennas is lower than in single stream case. Higher gain would be achievable by exploiting a more frequency selective precoding [16], but as mentioned above this solution would increase both the feedback overhead and the PAPR of the transmit signals. SVD codebook with 4 bits of feedback overhead here performs worse than Rel.8 codebook; this behaviour can be explained by an increase of the losses due to the quantization of the 4×2 V matrix with respect to the 4×1 V matrix used for rank 1 transmission. Note that the improvement obtained with a codebook requiring 8 bits of FO is again small.

Table 2 and Table 3 summarize the approximate average gain of the discussed options for the precoded transmission over the OL for 2x2 and 4x4 cases, respectively. The SVD codebook results therefore to be slightly more advantageous than Rel.8 one only when a larger feedback overhead can be tolerated.

V. CONCLUSIONS AND FUTURE WORK

In this paper, the Release 8 downlink codebooks are compared with codebooks based on SVD of the channel matrix in a closed loop single user MIMO system for the uplink of the upcoming LTE-A systems. Results show that, the SVD codebooks lead to the same performance gain of Rel.8 codebooks over OL for single stream transmission; extending the codebook size only gives a small improvement in terms of spectral efficiency. In case of multistream transmission, Rel.8 codebooks still behave better than the SVD-based. Considering that an SVD based codebook doesn't even exploit several advantages of the Rel.8 codebook (specifically the equal power allocation among the streams), we conclude that codebooks following the structure of the Rel.8 downlink ones are a more valid option for the precoded Single User MIMO transmission of LTE-A UL. As a future work, further improvements of the Rel.8 codebook allowing to keep the low PAPR constraint of

TABLE II
GAINS OF PRECODING OVER OL TRANSMISSION FOR 2TX

R	Gain over OL $R \times 2$			
	Rel.8	SVD 4 bits	SVD 8bits	SVD no quant
1	2 dB	2 dB	2.55 dB	4 dB

TABLE III
GAINS OF PRECODING OVER OL TRANSMISSION FOR 4TX

R	Gain over OL $R \times 4$			
	Rel.8	SVD 4 bits	SVD 8bits	SVD no quant
1	2.4 dB	2.4 dB	2.9 dB	5 dB
2	1 dB	0.5 dB	1.6 dB	4.5 dB
3	1 dB	0.3 dB	1.1 dB	3.9 dB

SC-FDM signals even with a more frequency selective precoding strategy will be analyzed. This comes at the expenses, of course, of a larger feedback overhead.

REFERENCES

- [1] "Requirements for further advancements for E-UTRA (LTE-Advanced)," 3rd Generation Partnership Project, Tech. Rep. TR 36.913, V8.0.0, 2008.
- [2] "LTE Physical Layer - General Description (Release 8)," 3rd Generation Partnership Project, Tech. Rep. TS 36.201, V8.1.0, Nov. 2007.
- [3] L. Hanzo, M. Munster, B. Choi, and T. Keller, *OFDM and MC-CDMA for Broadband MultiUser Communications, WLANs and Broadcasting*. John Wiley - IEEE Press, 2003.
- [4] H. Myung, J. Lim, and D. Goodman, "Single carrier FDMA for uplink wireless transmission," *Vehicular Technology Magazine, IEEE*, vol. 2, no. 3, pp. 30–38, September 2006.
- [5] "Text proposal for TR36.814 on uplink transmission scheme," 3GPP TSG-RAN WG1 Meeting 55bis, R1-090532, Tech. Rep.
- [6] B. Clerckx, Y. Zhou, and S. Kim, "Practical Codebook Design for Limited Feedback Spatial Multiplexing," *IEEE International Conference on Communications, 2008. ICC '08*, pp. 3982–3987, May 2008.
- [7] "Capacity of multi-antenna gaussian channels," ATT Bell Labs, Tech. Rep. Technical Memorandum, 1995.
- [8] P. Sampath, H. Stoica and A. Paulraj, "Generalized linear precoder and decoder design for MIMO channels using the weighted MMSE criterion," *IEEE Transaction on Communications*, vol. 49, no. 12, pp. 2198–2206, Dec. 2001.
- [9] A. Scaglione, P. Stoica, S. Barbarossa, G. Giannakis, and H. Sampath, "Optimal designs for space-time linear precoders and decoders," *IEEE Transaction on Signal Processing*, vol. 5, no. 5, pp. 1051–1064, May 2002.
- [10] D. Falconer, S. Ariyavisitakul, A. Benyamin-Seeyar, and B. Eidson, "Frequency domain equalization for single-carrier broadband wireless systems," *IEEE Communications Magazine*, vol. 40, no. 4, pp. 58–66, Apr 2002.
- [11] "Codebook Design for E-UTRA MIMO Pre-coding," 3GPP TSG-RAN WG1 Meeting 46 R1-062016, Tech. Rep., September 2006.
- [12] G. Golub and C. Loan, *Matrix Computation (3rd ed.)*. Johns Hopkins University Press, Baltimore, MD, USA, 1996.
- [13] G. Berardinelli, L. Maestro Ruiz de Temiño, S. Frattasi, T. Sørensen, P. Mogensen, and K. Pajukoski, "On the Feasibility of Precoded Single User MIMO for LTE-A Uplink," *Journal of Communications, Special Issue on Wireless Gigabit Technologies*, pp. 155–163, Apr. 2009.
- [14] E. Sengul, H. Park, and E. Ayanoglu, "Bit-Interleaved Coded Multiple Beamforming with Imperfect CSIT," *IEEE Transactions on Communications*, pp. 1505–1513, May 2009.
- [15] A. Gersho and R. Gray, *Vector Quantization and Signal Compression*. Norwell, MA: Kluwer Academic, 1992.
- [16] G. Berardinelli, T. Sørensen, P. Mogensen, and K. Pajukoski, "Precoded multitransmission with linear receivers for LTE-A Uplink," in *the Proceeding of IEEE 70th Vehicular Technology Conference, VTC2009-Fall*, Sept. 2009.