



# System Concepts for Affordable Fission Surface Power

*Lee Mason  
Glenn Research Center, Cleveland, Ohio*

*David Poston  
Los Alamos National Laboratory, Los Alamos, New Mexico*

*Louis Qualls  
Oak Ridge National Laboratory, Oak Ridge, Tennessee*

## NASA STI Program . . . in Profile

Since its founding, NASA has been dedicated to the advancement of aeronautics and space science. The NASA Scientific and Technical Information (STI) program plays a key part in helping NASA maintain this important role.

The NASA STI Program operates under the auspices of the Agency Chief Information Officer. It collects, organizes, provides for archiving, and disseminates NASA's STI. The NASA STI program provides access to the NASA Aeronautics and Space Database and its public interface, the NASA Technical Reports Server, thus providing one of the largest collections of aeronautical and space science STI in the world. Results are published in both non-NASA channels and by NASA in the NASA STI Report Series, which includes the following report types:

- **TECHNICAL PUBLICATION.** Reports of completed research or a major significant phase of research that present the results of NASA programs and include extensive data or theoretical analysis. Includes compilations of significant scientific and technical data and information deemed to be of continuing reference value. NASA counterpart of peer-reviewed formal professional papers but has less stringent limitations on manuscript length and extent of graphic presentations.
- **TECHNICAL MEMORANDUM.** Scientific and technical findings that are preliminary or of specialized interest, e.g., quick release reports, working papers, and bibliographies that contain minimal annotation. Does not contain extensive analysis.
- **CONTRACTOR REPORT.** Scientific and technical findings by NASA-sponsored contractors and grantees.
- **CONFERENCE PUBLICATION.** Collected

papers from scientific and technical conferences, symposia, seminars, or other meetings sponsored or cosponsored by NASA.

- **SPECIAL PUBLICATION.** Scientific, technical, or historical information from NASA programs, projects, and missions, often concerned with subjects having substantial public interest.
- **TECHNICAL TRANSLATION.** English-language translations of foreign scientific and technical material pertinent to NASA's mission.

Specialized services also include creating custom thesauri, building customized databases, organizing and publishing research results.

For more information about the NASA STI program, see the following:

- Access the NASA STI program home page at <http://www.sti.nasa.gov>
- E-mail your question via the Internet to [help@sti.nasa.gov](mailto:help@sti.nasa.gov)
- Fax your question to the NASA STI Help Desk at 301-621-0134
- Telephone the NASA STI Help Desk at 301-621-0390
- Write to:  
NASA Center for AeroSpace Information (CASI)  
7115 Standard Drive  
Hanover, MD 21076-1320



# System Concepts for Affordable Fission Surface Power

*Lee Mason*

*Glenn Research Center, Cleveland, Ohio*

*David Poston*

*Los Alamos National Laboratory, Los Alamos, New Mexico*

*Louis Qualls*

*Oak Ridge National Laboratory, Oak Ridge, Tennessee*

Prepared for the  
Space Technology and Applications International Forum (STAIF-2008)  
sponsored by the Institute for Space and Nuclear Power Studies at the University of New Mexico  
Albuquerque, New Mexico, February 10-14, 2008

National Aeronautics and  
Space Administration

Glenn Research Center  
Cleveland, Ohio 44135

## Acknowledgments

This concept definition resulted from a 12 month joint NASA/DOE study. In addition to the authors, the main study team consisted of Joe Nainiger, Dick Shaltens, and Bob Sefcik from GRC, Mike Houts from MSFC, Shawn Quinn from KSC, Paul Van Damme from JPL, Ray Holdaway, Dwight Clayton, and Becky Moses from ORNL, Jim Werner from INL, and Steve Wright from SNL. Abe Weitzberg, Sterling Bailey, and Sam Bhattacharyya served as consultants. John Warren was the NASA Headquarters sponsor, and Scott Harlow was the DOE Headquarters representative. This work was performed for the NASA Exploration Systems Mission Directorate, Advanced Capabilities Division.

This report contains preliminary findings,  
subject to revision as analysis proceeds.

This report is a preprint of a paper intended for presentation at a conference.  
Because changes may be made before formal publication, this preprint is made available  
with the understanding that it will not be cited or reproduced without  
the permission of the author.

*Level of Review:* This material has been technically reviewed by technical management.

Available from

NASA Center for Aerospace Information  
7115 Standard Drive  
Hanover, MD 21076-1320

National Technical Information Service  
5285 Port Royal Road  
Springfield, VA 22161

Available electronically at <http://gltrs.grc.nasa.gov>

# **System Concepts for Affordable Fission Surface Power**

Lee Mason  
National Aeronautics and Space Administration  
Glenn Research Center  
Cleveland, Ohio 44135

David Poston  
Los Alamos National Laboratory  
Los Alamos, New Mexico 87545

Louis Qualls  
Oak Ridge National Laboratory  
Oak Ridge, Tennessee 37831

## **Abstract**

This paper presents an overview of an affordable Fission Surface Power (FSP) system that could be used for NASA applications on the Moon and Mars. The proposed FSP system uses a low temperature, uranium dioxide-fueled, liquid metal-cooled fission reactor coupled to free-piston Stirling converters. The concept was determined by a 12 month NASA/DOE study that examined design options and development strategies based on affordability and risk. The system is considered a low development risk based on the use of terrestrial-derived reactor technology, high efficiency power conversion, and conventional materials. The low-risk approach was selected over other options that could offer higher performance and/or lower mass.

## **Introduction**

Under the Vision for Exploration, NASA is evaluating options for human missions to the Moon and Mars. New and more capable power systems will be required to supply energy for sustained surface outposts. Lunar missions are expected to begin in the early 2020s. Mars missions may occur later, possibly in the 2030s. Some potential surface power electrical loads include landers, habitats, in-situ resource utilization plants, mobility and construction equipment, and science experiments. Total power requirements could range from 10 kWe to more than 100 kWe. The unique environments of the Moon and Mars pose many challenges for power systems. The 29.5-day lunar rotational period requires that extended surface missions include the capability for at least 354 hr of nighttime energy storage. Other lunar mission challenges include tenacious dust adhesion and extreme surface temperatures ranging from 375 K at lunar noon to 100 K during lunar night. The typical Mars equatorial day is 24.6 hr long with about 12 hr of night, so energy storage requirements are significantly less than the Moon. However, because of the greater distance from the Sun and the attenuation through the atmosphere, insolation at the Martian surface is reduced to about 20 percent of that on the Moon, and that value decreases significantly with dust storms. The potentially corrosive, carbon-dioxide atmosphere at Mars may also present problems for the power system. For either the Moon or Mars, power systems must be highly reliable to assure steady and continuous power for crew safety. The combination of high power, difficult environmental conditions, and assured reliability make fission-based power systems an advantageous option among the various power system choices.

One of the major challenges to the implementation of space fission power systems is development cost. In April 2006, NASA and DOE initiated the Affordable Fission Surface Power System Study (AFSPSS) to determine the design features and expected costs of a representative Fission Surface Power (FSP) system. A government study team with members from several NASA field centers and Department

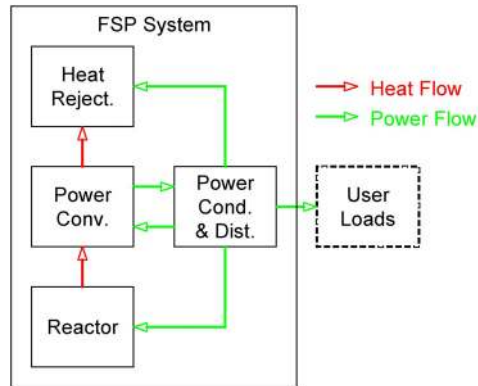

Figure 1.—Simplified FSP system block diagram.

of Energy (DOE) laboratories evaluated technology options and design variables and selected a reference concept based on affordability and risk. A low-risk approach was selected over other options that could offer higher performance and/or lower mass. The reference concept does not reflect a decision or down-selection for system development, but merely a strawman for the purposes of estimating system cost. The reference concept is considered representative of a number of potential affordable designs. This paper describes the reference concept and reviews the top-level screening studies conducted by the government team as a basis for the selection.

The FSP system block diagram, shown in figure 1, is defined by four major subsystems: (1) Reactor, (2) Power Conversion, (3) Heat Rejection, and (4) Power Conditioning and Distribution (PCAD). Heat is transferred from the Reactor to the Power Conversion and from the Power Conversion to the Heat Rejection. Electrical power generated by the Power Conversion is processed through the PCAD to the User Loads. The PCAD provides power for Power Conversion startup and for auxiliary loads associated with the Reactor and Heat Rejection. The PCAD also provides the primary communications link for command, telemetry, and health monitoring of the FSP system.

## Screening Studies

The sections below describe some of the key trades performed by the government team in arriving at the reference concept selection. The primary design variables considered in arriving at the reference concept were: (1) Power Level and Life, (2) Reactor-Converter Combination, and (3) System Configuration. Power level and design life have a major influence on cost. Higher power increases design complexity. Longer life expands test qualification requirements. The decision on reactor and power conversion type affects system performance and complexity. The use of mature technology minimizes development risk and cost. System configuration relates to the packaging options and installation requirements of the system. Two options were considered. The “emplaced” option uses regolith shielding to reduce mass and permit near outpost siting. The “landed” option reduces the reliance on crew and equipment for installation.

### Power Level and Life

A notional lunar outpost power profile was assumed at 30 kWe for the first 5 years and 80 kWe for 15 years thereafter, as shown in figure 2, with power levels specified at the user load interface. Five FSP architectures were considered by the government team:

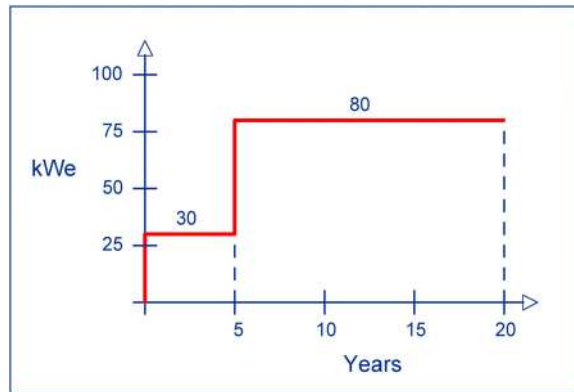

Figure 2.—Assumed mission power profile.

- (1) 80 kW<sub>e</sub>/20-yr design operated at a de-rated power level of 30 kW<sub>e</sub> for the first 5 years,
- (2) 80 kW<sub>e</sub>/15-yr design with the first system de-rated to 30 kW<sub>e</sub>/5-yr and the second system delivered in year five,
- (3) 80 kW<sub>e</sub>/8-yr design with the first system de-rated to 30 kW<sub>e</sub>/5-yr and subsequent systems delivered in year five and year twelve,
- (4) 40 kW<sub>e</sub>/8-yr design with the first system de-rated to 30 kW<sub>e</sub>/5-yr and subsequent systems delivered in pairs in year five and year twelve, and
- (5) 40 kW<sub>e</sub>/5-yr design with the first system de-rated to 30 kW<sub>e</sub> and subsequent systems delivered in pairs in year five, year ten, and year fifteen.

In all cases, the design rating forms the basis for the system design and development effort. In cases where the initial system is de-rated, the qualification effort could be reduced in scope commensurate with the de-rating.

Based on a qualitative assessment of the options, the government team selected the 40 kW<sub>e</sub>/8-yr design option for the AFSPSS costing exercise. This results in a requirement for five systems and three launches to meet the 20 yr mission profile. The lower power and shorter life were considered major benefits in achieving an affordable system. The use of two independent systems to meet the out-year power requirements was considered advantageous.

### Reactor-Converter Combination

A matrix of system concepts, as shown in table I, was generated by selecting reactor fuel, primary coolant, power conversion type, and radiator coolant. These combinations were considered as practical options for this study given the assumed power requirements and affordability goal. The affordability goal led to a decision by the government team to limit reactor fuel-clad temperature to 900 K to minimize fuel and material development costs and maximize the use of existing technology. Fuel options were UO<sub>2</sub>, UN, U10Zr (all fast-spectrum), and UZrH (moderated). The coolant options included pumped liquid metal (either sodium-potassium (NaK) or sodium (Na)), potassium heat pipes, and inert gas (HeXe). The power conversion options included Free-Piston Stirling (FPS), Closed Brayton Cycle (CBC), PbTe/TAGS Thermoelectrics (TE), and Organic Rankine Cycle (ORC). All of the options, with the exception of the TE concept, use a water-based radiator cooling system. The higher rejection temperature for TE required the use of NaK as the radiator coolant.

TABLE I.—REACTOR-CONVERTER COMBINATIONS AND TRADE SPACE

Concept	A	B	C	D	E	F	G	H	I	J
Reactor Fuel	UO <sub>2</sub>	UO <sub>2</sub>	UO <sub>2</sub>	UN	U10Zr	UZrH (Mod.)	UO <sub>2</sub>	UO <sub>2</sub>	UO <sub>2</sub>	UO <sub>2</sub>
Primary Coolant	NaK	Na	K HP	NaK	NaK	NaK	HeXe	NaK	NaK	NaK
Power Conversion	FPS	FPS	FPS	FPS	FPS	FPS	CBC	CBC	TE	ORC
Radiator Coolant	H <sub>2</sub> O	H <sub>2</sub> O	H <sub>2</sub> O	H <sub>2</sub> O	H <sub>2</sub> O	H <sub>2</sub> O	H <sub>2</sub> O	H <sub>2</sub> O	NaK	H <sub>2</sub> O

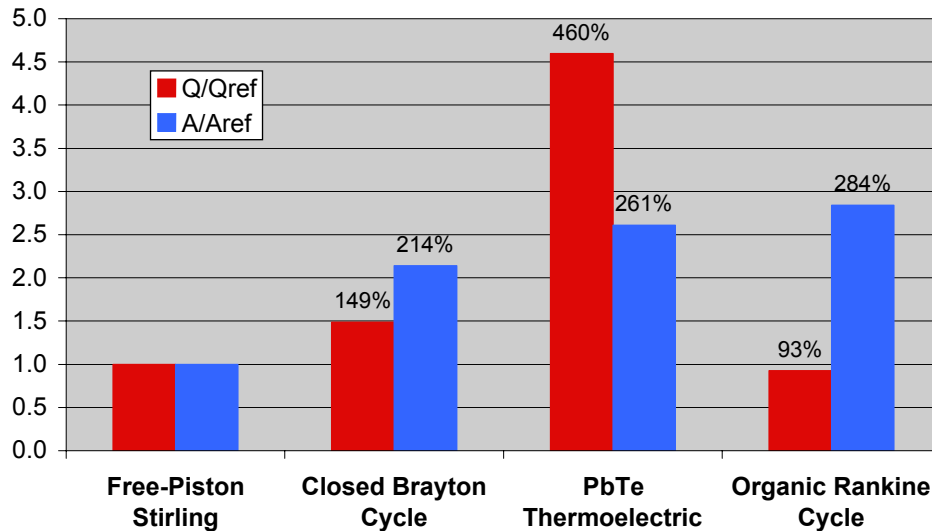

Figure 3.—Screening study sample results.

An initial screening of these concepts by the government team resulted in estimates for reactor thermal power, radiator area, and system mass. A sample of the screening study results is provided in figure 3 showing a comparison of reactor thermal power and radiator area for the various power conversion options assuming a 900 K pumped-NaK reactor heat source. Based on these and other screening study results and a qualitative assessment of technology readiness, the government team selected Concept A (UO<sub>2</sub>, NaK, FPS) as the reference for the AFSPSS costing exercise. This concept uses relatively low-risk reactor technology combined with a power conversion approach that provides high conversion efficiency and low radiator area.

### System Configuration

There were two system configurations studied by the government team: landed and emplaced. The landed configuration, shown in figure 4, assumes the FSP system remains on a dedicated lander with integral, Earth-delivered shielding. The primary advantage of this configuration is ease of deployment because no regolith moving equipment is needed for the installation and it is possible that it could be deployed without crew assistance. The system is located approximately 1 km from the outpost in order to reduce shield mass. The integral, shaped 4-pi shield reduces radiation levels to less than 5 rem/yr at 1 km in the direction of the outpost and less than 50 rem/yr elsewhere. The PCAD subsystem converts the 400 V power conversion output to 2000 V for transmission and 120 Vdc for distribution to the loads. The installation of the power transmission cable would require crew assistance or a tele-operated rover. An autonomously deployed, vertical radiator is extended from the lander via a truss structure.



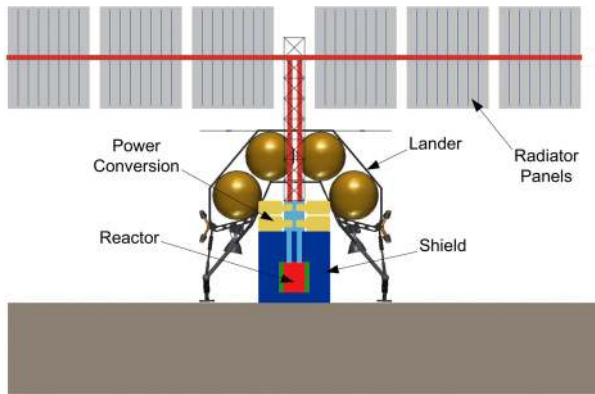

Figure 4.—Landed configuration.

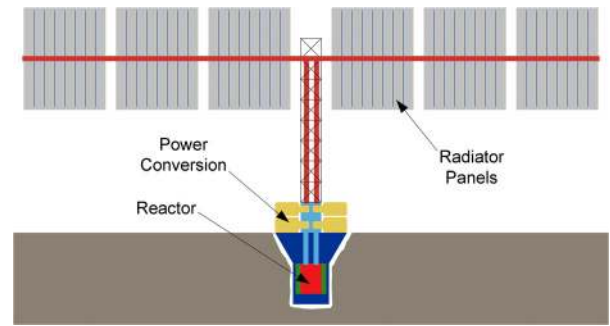

Figure 5.—Emplaced configuration.

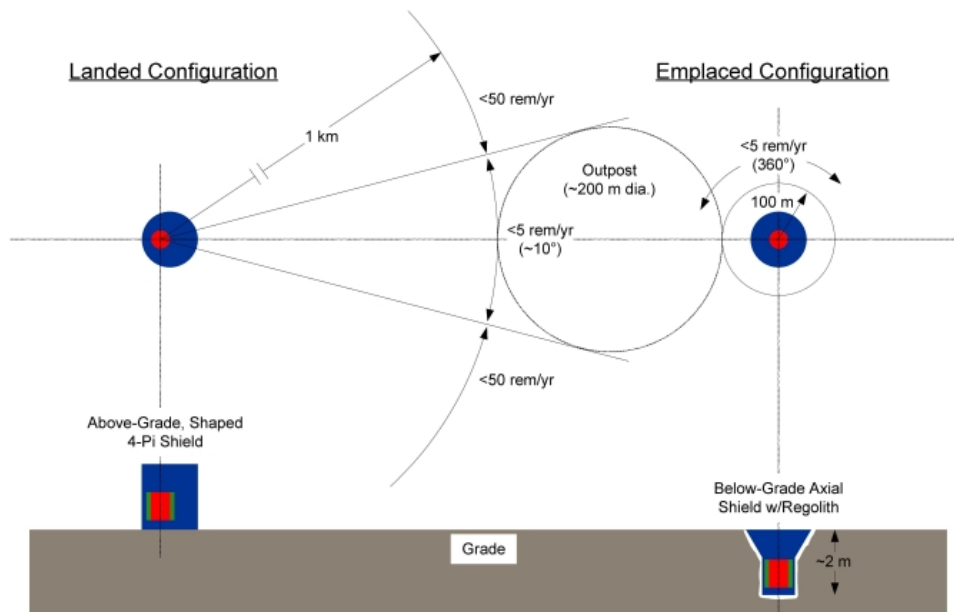

Figure 6.—Shield geometry assumptions.

The emplaced configuration, shown in figure 5, assumes the FSP system is off-loaded from a cargo lander and installed with the assistance of crew and construction equipment. The line-of-sight reactor shielding to the habitat is provided by regolith, either by burying the reactor or moving regolith to form a berm. Additional Earth-delivered shielding would be provided to protect power conversion and heat rejection equipment mounted above the reactor. The FSP system is located approximately 100 m from the outpost. The combination of regolith and integral shielding reduces radiation levels to less than 5 rem/yr at 100 m in all directions (360°). The improved shielding allows the potential for simple, short-term maintenance tasks such as electrical part replacements or radiator surface cleaning during temporary zero-power shutdowns. The PCAD subsystem directly transmits the 400 V power conversion output to the load distribution node where it is converted to 120 Vdc. An autonomously deployed, vertical radiator is extended above the reactor and power conversion equipment. The availability of crew to oversee the deployment could potential simplify design and qualification requirements. The shielding geometry assumptions for the two configurations are shown in figure 6.

The landed configuration is considered an excellent choice if the first system must be delivered before suitable construction infrastructure is available for the emplaced configuration. However, the FSP system mass for the landed configuration was estimated to be approximately twice that of the emplaced configuration. The landed configuration would also impose some potential constraints on crew operations and outpost expansion. Based on the lower mass and reduced operational constraints, the government study team selected the emplaced configuration as the reference approach for the costing exercise. However, the self-shielded, landed configuration with high voltage transmission was retained as a potential design option.

## Preliminary Reference Concept

The reference FSP system for the AFSPSS costing effort is a stainless-steel, UO<sub>2</sub> fueled, pumped-NaK cooled reactor with Stirling power conversion and pumped-water heat rejection. Figure 7 presents a notional layout for the concept. The deployed span is approximately 34 m tip-to-tip and 5 m above grade. The bottom edge of the radiators is approximately 1 m above the surface to minimize the potential for dust on the radiator surfaces. The reactor is located at the bottom of a 2 m excavation with an upper plug shield protecting the equipment above from direct radiation. Figure 8 shows the concept in a stowed configuration for delivery to the lunar site. The stowed envelope is approximately 3 by 3 by 7 m tall. The NaK pumps, Stirling power converters, and radiator pumps are mounted on a 5 m tall truss structure that attaches to the top face of the plug shield. The two symmetric radiator wings are deployed via a scissor mechanism from the truss, similar in concept to the International Space Station (ISS) radiators. The vertical orientation permits two-sided radiation, providing a much smaller footprint than one-sided horizontal radiators that view only deep space. A pair of cavity radiators remove waste heat from components within the excavated hole, with deployment linkages that are connected to the main radiator's mechanism.

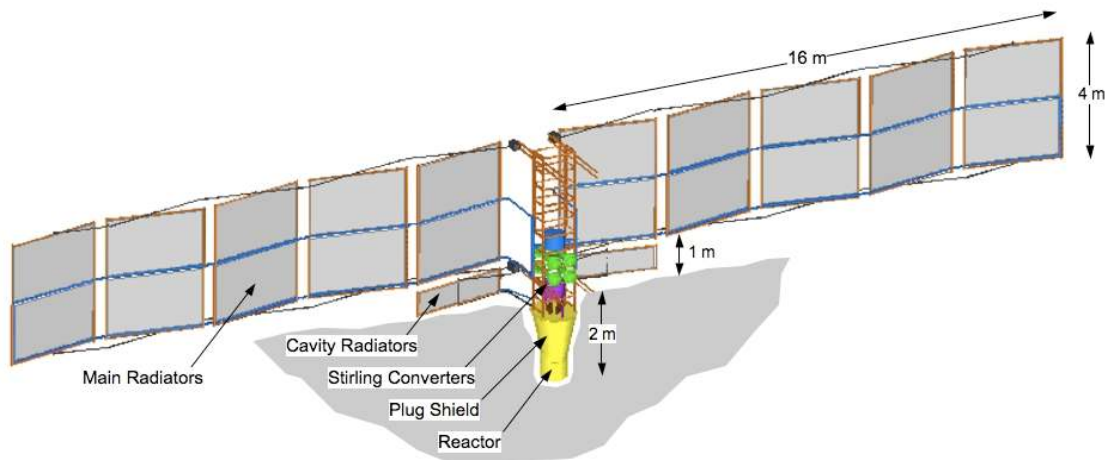

Figure 7.—Reference concept layout.

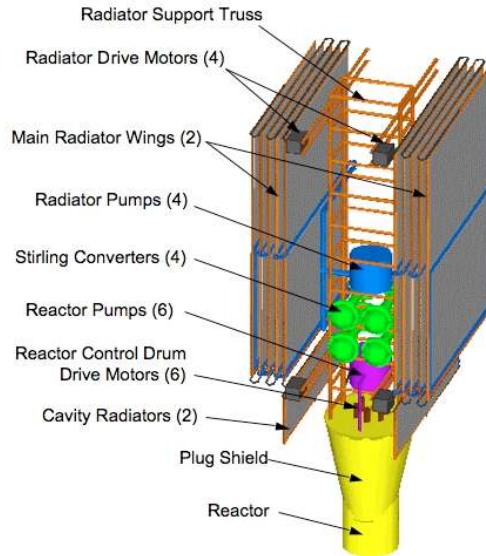

Figure 8.—Reference concept in stowed configuration.

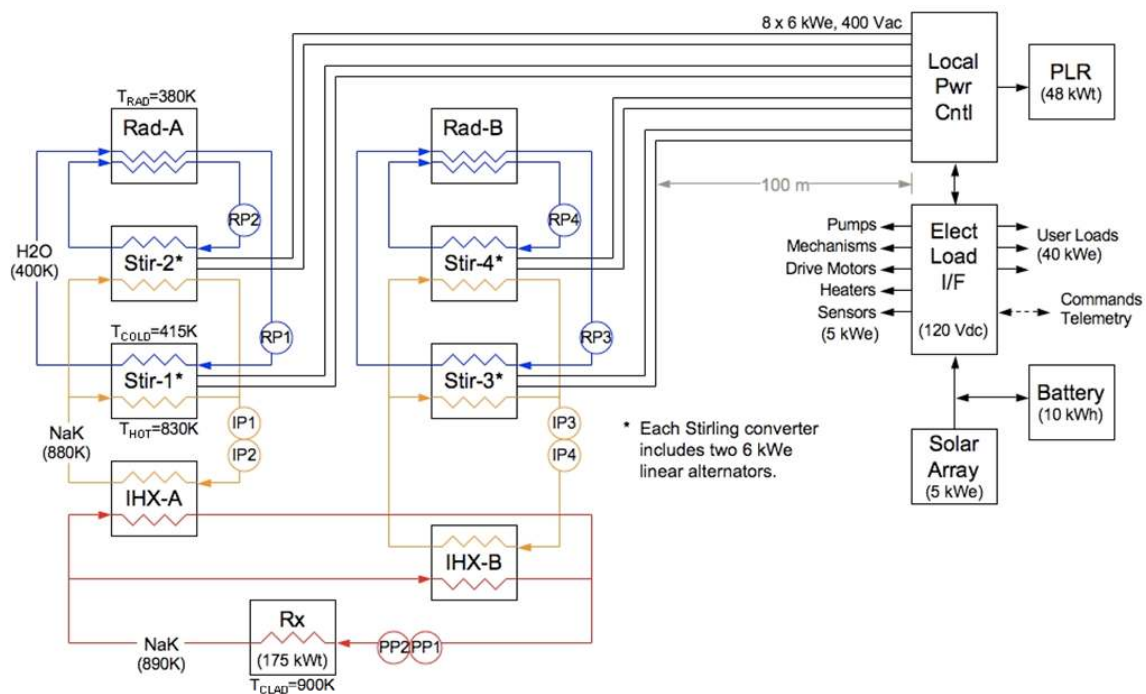

Figure 9.—Reference concept system schematic.

## System Schematic

The preliminary system schematic for the emplaced FSP configuration is shown in figure 9. The schematic indicates the reference fluid selections, operating temperatures, component redundancy levels, and overall PCAD architecture. The reactor (Rx) produces approximately 175 kWt with a peak clad temperature of 900 K and delivers heated NaK at 890 K to a pair of intermediate heat exchangers (IHX) via two, redundant primary pumps. The IHX is a NaK-to-NaK heat exchanger that isolates the primary NaK from the Stirling converters and permits the NaK interface temperatures to be optimized for the

Stirling, while the primary NaK conditions can be tailored for the reactor. Each intermediate NaK loop includes redundant pumps and services two Stirling converters at a supply temperature of 880 K. The average Stirling hot-end temperature is 830 K. Each Stirling converter has a dedicated cooling loop with a 400 K water exit temperature. The effective radiator temperature is 380 K. The use of redundant components and parallel fluid loops permit the system to produce partial power in the event of failures.

Each Stirling converter is comprised of two, axially opposed Stirling heat engines and two linear alternators. The alternators deliver 6 kWe each at 400 Vac and 100 hz to a Local Power Controller, located 100 m from the reactor. The power controller converts the 400 Vac to 120 Vdc for distribution to the Electrical Load Interface. The 48 kWe gross output power provides sufficient margin for electrical losses (~3 kWe) and system parasitic loads (~5 kWe) in meeting the 40 kWe of user loads. A full power Parasitic Load Radiator (PLR) dissipates power that is not required by the user loads, and allows the system to be operated in a near-steady thermal mode by isolating it from electrical load fluctuations. The Load Interface serves as the primary power bus and system interface for commands and telemetry. A 5 kWe solar array and 10 kWh battery are included for startup and backup power.

### Reactor and Shield

The reactor and shield concepts developed for this cost study are described in detail in a companion paper by Poston, et al. (2008). The reactor core is shown in figure 10 and the overall reactor assembly is depicted in figure 11. The core consists of 85 UO<sub>2</sub> fuel pins (93 percent enrichment) in stainless steel cladding, and is approximately 20 cm in diameter. The peak fuel burn-up is estimated at 1.3 at.% for the 8 yr design life. Reactivity control is provided by six radial beryllium (Be) reflector drums. The outer stainless steel vessel is dodecagon-shaped for tight packaging with the radial reflectors. The reactor coolant is a 78 percent Na, 22 percent K mixture that can more easily be maintained as a liquid prior to startup because of its relatively low 262 K freezing temperature. Both the primary and intermediate loops use electromagnetic pumps with an assumed pumping efficiency of 10 percent. A water heat pipe cooling shroud surrounds the buried portion of reactor module and removes about 5 kWt of fission power that is deposited in the reflectors and shield. The heat pipes transfer the heat to the cavity cooling radiator panels located above the surface. The shield consists of boron-carbide (B<sub>4</sub>C) in a stainless steel container providing both neutron and gamma attenuation. The axial plug shield is approximately 1.2 m thick and has an elliptical top face of 1.2 by 1.5 m to accommodate the Stirling assembly footprint. A thinner radial shield, as shown in figure 11, may also be needed to reduce neutron leakage through the regolith. In the buried/emplaced configuration, the need for shielding is largely driven by the dose limits of the power conversion components. The baseline shield is designed to limit dose to 2 Mrad and  $1 \times 10^{14}$  n/cm<sup>2</sup> fast fluence to the Stirling alternator region, and the human dose limit of 5 rem/yr at the outpost location. A key safety feature of the FSP system is that the reactor remains subcritical during all planned and credible unplanned mission events prior to startup.

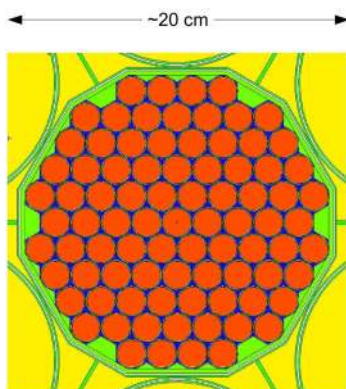

Figure 10.—Core cross-section.

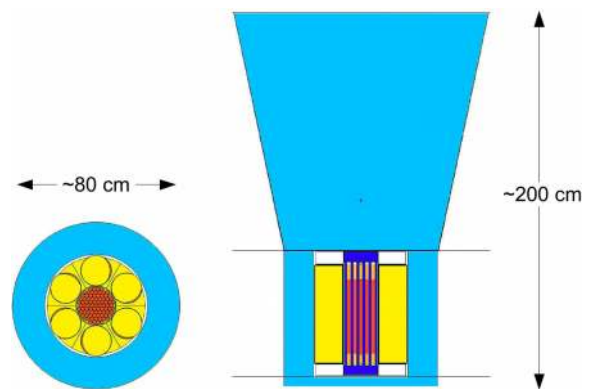

Figure 11.—Reactor and shield layout.

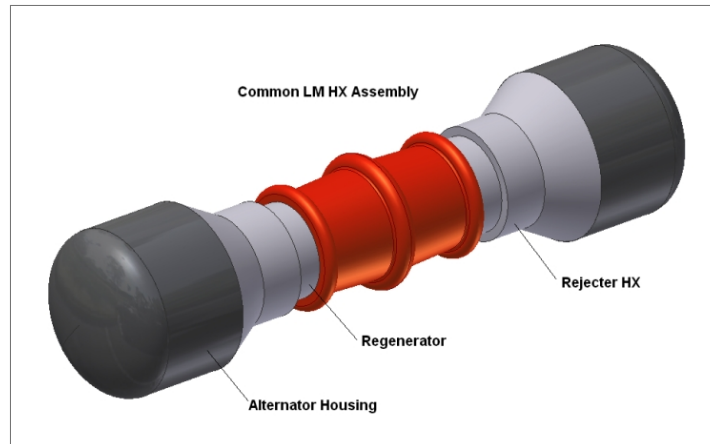

Figure 12.—12 kWe dual-opposed Stirling converter concept.

### Power Conversion and PCAD

The FSP system uses four Stirling converters that produce approximately 12 kWe each. A notional Stirling converter is shown in figure 12. The converter is comprised of two, axially opposed free-piston engines coupled to linear alternators and is approximately 1.2 m in length. The engines are connected via a common expansion space similar to the Space Power Demonstration Engine (SPDE) from the early 1980s. The Stirling engine is heated by pumped, single-phase NaK from the intermediate heat exchangers. A common liquid metal (LM) heat exchanger (HX) assembly transfers heat from the NaK into the Stirling heater heads. The HX assembly includes a single centered inlet manifold, flow annulus, and two exit manifolds that form a jacket over the monolithic heater heads. The HX provides uniform heating with reasonable fluid velocity and negligible pressure drop. The Stirling converter uses an IN718 heater head and operates at 830 K hot-end and 415 K cold-end, which is well within the experience base for free-piston Stirling technology. Under these conditions, the Stirling converter is approximately 28 percent efficient. The linear alternators deliver 6 kWe each at 400 Vac, 100 hz single-phase directly to the Local Power Controller, where the power is converted to 120 Vdc for the loads. A PLR provides a full power electrical shunt to compensate for user load variations, and allows the Stirling converters to operate in a constant power mode.

### Heat Rejection

The heat rejection subsystem includes pumped water heat transport and two-sided composite radiator panels with titanium-water heat pipes. The heat rejection subsystem is comprised of four water heat transport loops and two radiator wings (two loops per wing). Figure 13 shows a fluid schematic for one wing, which services two Stirling converters. Each heat rejection loop has a dedicated pump and volume accumulator. The radiator assembly receives heated water at 400 K from the Stirling converters and returns the water at 370 K, while rejecting approximately 30 kWt per loop. The radiator wings include individual radiator panels with flexible interconnects that can be stowed in an “accordion” arrangement prior to deployment. The radiator panels use a sandwich construction with aluminum honeycomb filler and regularly spaced titanium-water heat pipes between two polymer-matrix composite facesheets. The circular heat pipes are supported in graphite saddles that provide the thermal interface to the facesheets. Heat is transferred from the pumped water heat transport loops to the water heat pipes via a manifold with bumper shielding for protection from micrometeoroids. The heat pipes include a bent evaporator section to maximize heat transfer area and provide efficient packaging with the two coolant channels. The total heat rejected is approximately 120 kWt and the total two-sided FSP system radiator area is 175 m<sup>2</sup>, including a 10 percent area margin. Radiator sizing is based on worst-case, equatorial sun angles and the



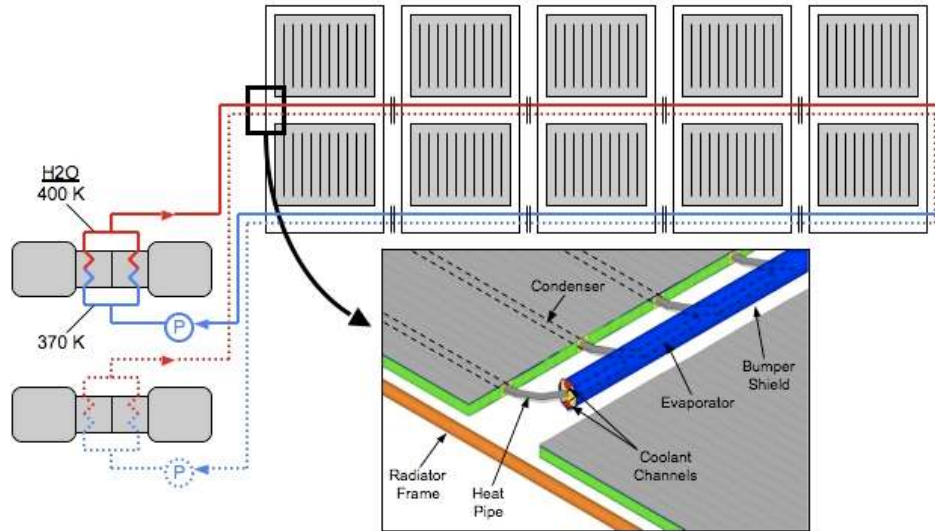

Figure 13.—Heat rejection and radiator panel concepts.

TABLE II.—REFERENCE CONCEPT MASS SUMMARY

	Mass, kg	Comment
Reactor	913	93 percent enriched UO <sub>2</sub> , NaK coolant, SS-316 cladding/structure, Be drum reflectors, 1 primary and 2 intermediate loops, 6 EM pumps, 175 kWt, 900K peak clad temp, cavity radiators
Shield	1676	B4C and SS-316, 1.2-m-thick axial plug, 1.2 by 1.5 m elliptical face, <2 Mrad and $1 \times 10^{14}$ n/cm <sup>2</sup> at Stirling converters, lunar regolith augmentation, <5 rem/yr at 100 m radial distance
Power conversion	344	Free-piston Stirling, 4 dual-opposed converters, 8 linear alternators $\times$ 6 kWe, 100 Hz, T <sub>H</sub> = 830 K, T <sub>C</sub> = 415 K
Heat rejection	615	Pumped H <sub>2</sub> O coolant, 4 independent loops, 400 K inlet temp, composite radiator panels with Ti/H <sub>2</sub> O heat pipes, scissor deployment, mylar surface apron, 175 m <sup>2</sup> total area
Power conditioning and distribution	559	400 Vac distribution, 100 m cabling, 120 Vdc user bus, parasitic load control, comm/telemetry link, 5 kWe solar array, 10 kWh battery
Subtotal	4107	
Margin	821	20 percent
Total	4928	

use of a low-absorptivity, low-emissivity mylar surface apron to reduce the thermal contribution from the surface, resulting in an effective radiator sink temperature of about 250 K. A radiator wing includes 10 sub-panels, each measuring approximately 2.5 m wide by 1.75 m tall.

### System Mass

The FSP system mass summary is presented in table II. The total system mass is approximately 4100 kg, and less than 5000 kg with 20 percent mass margin. The reactor, including the fuel pins, vessel, control drums, heat transport, and cavity cooling, is 913 kg, or 22 percent of the total mass. The shield is the heaviest subsystem comprising over 41 percent of the total mass. The shield also has the greatest potential for mass reduction, should the radiation limits at the Stirling converters be relaxed or alternative shield materials such as water or lithium-hydride be considered. The power conversion mass is the smallest at 344 kg, or 8 percent of the total mass. The Stirling converters account for the majority of the power conversion subtotal having a specific mass of approximately 6 kg/kWe. The heat rejection subsystem is about 15 percent of the total mass at 615 kg. The radiator panels are about 4.3 kg/m<sup>2</sup> (based

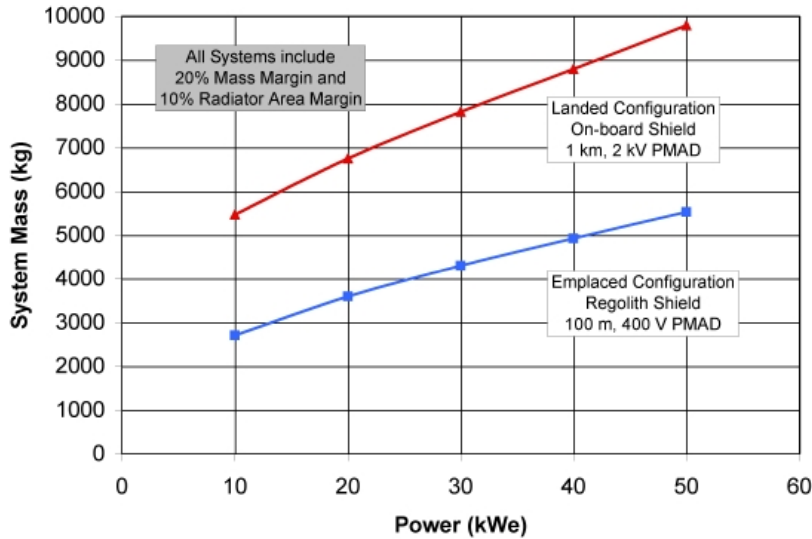

Figure 14.—System mass scaling for emplaced and landed configurations.

on 1-sided area), while the overall heat rejection subsystem is about  $7 \text{ kg/m}^2$ . The PCAD mass is estimated at 559 kg or 14 percent of the total mass. This mass includes the 5 kWe solar array (based on 100 W/kg array technology) and the 10 kWh battery (based on 100 Whr/kg battery technology).

Figure 14 shows the estimated system mass scaling over the power range from 10 to 50 kWe, including the 20 percent margin. Both the emplaced (reference) and landed configurations masses are shown, with the landed configuration based on the assumptions stated previously (full earth-delivered on-board shielding, 1 km separation, and 2000 V power transmission). At 40 kWe, the landed system is estimated to be 8800 kg, an 80 percent increase over the emplaced configuration. The two curves exhibit a relatively shallow slope which is typical of space reactors. While there is modest mass savings by reducing power level, there is also modest mass increase for higher power systems.

## Conclusion

NASA and DOE conducted a 12 month study to estimate the cost of a FSP system for lunar and Mars missions. Screening studies were performed to evaluate technology options and design variables before selecting a preliminary reference concept for costing. The screening studies led to a UO<sub>2</sub>-fueled, NaK-cooled reactor with Stirling power conversion and water-based heat rejection capable of providing 40 kWe with an 8 yr design life. The reference system is emplaced in a pre-excavated hole to allow near-outpost siting and reduce radiation levels to less than 5 rem/yr at 100 m separation distance. The reactor uses stainless steel construction, limiting nominal coolant temperatures to less than 900 K, in order to minimize development cost and leverage terrestrial technology. Stirling power conversion is well suited to the operating temperature, providing high efficiency at relatively high heat rejection temperature. The use of water heat transport and water heat pipe radiator panels provides efficient waste heat removal, using a deployment approach that is derived from the ISS radiators. The FSP system concept is extensible to Mars, with materials and design strategies that are fully compatible with the Martian environment. The total system mass with 20 percent margin is less than 5000 kg.

## Reference

Poston, D.I., Kapernick, R.J., Dixon, D.D., Amiri, B.W., and Marcille, T.F., “Reference Reactor Module for the Affordable Fission Surface Power System,” in the Proceedings of the *Space Technology and Applications International Forum (STAIF-2008)*, edited by M.S. El-Genk, AIP Conference Proceedings, Melville, New York, 2008.

**REPORT DOCUMENTATION PAGE**

*Form Approved*  
OMB No. 0704-0188

The public reporting burden for this collection of information is estimated to average 1 hour per response, including the time for reviewing instructions, searching existing data sources, gathering and maintaining the data needed, and completing and reviewing the collection of information. Send comments regarding this burden estimate or any other aspect of this collection of information, including suggestions for reducing this burden, to Department of Defense, Washington Headquarters Services, Directorate for Information Operations and Reports (0704-0188), 1215 Jefferson Davis Highway, Suite 1204, Arlington, VA 22202-4302. Respondents should be aware that notwithstanding any other provision of law, no person shall be subject to any penalty for failing to comply with a collection of information if it does not display a currently valid OMB control number.

PLEASE DO NOT RETURN YOUR FORM TO THE ABOVE ADDRESS.

<b>1. REPORT DATE (DD-MM-YYYY)</b> 01-01-2008		<b>2. REPORT TYPE</b> Technical Memorandum		<b>3. DATES COVERED (From - To)</b>	
<b>4. TITLE AND SUBTITLE</b> System Concepts for Affordable Fission Surface Power				<b>5a. CONTRACT NUMBER</b>	
				<b>5b. GRANT NUMBER</b>	
				<b>5c. PROGRAM ELEMENT NUMBER</b>	
<b>6. AUTHOR(S)</b> Mason, Lee; Poston, David; Qualls, Louis				<b>5d. PROJECT NUMBER</b>	
				<b>5e. TASK NUMBER</b>	
				<b>5f. WORK UNIT NUMBER</b> WBS 463169.02.03.01.01	
<b>7. PERFORMING ORGANIZATION NAME(S) AND ADDRESS(ES)</b> National Aeronautics and Space Administration John H. Glenn Research Center at Lewis Field Cleveland, Ohio 44135-3191				<b>8. PERFORMING ORGANIZATION REPORT NUMBER</b> E-16409	
<b>9. SPONSORING/MONITORING AGENCY NAME(S) AND ADDRESS(ES)</b> National Aeronautics and Space Administration Washington, DC 20546-0001				<b>10. SPONSORING/MONITORS ACRONYM(S)</b> NASA	
				<b>11. SPONSORING/MONITORING REPORT NUMBER</b> NASA/TM-2008-215166	
<b>12. DISTRIBUTION/AVAILABILITY STATEMENT</b> Unclassified-Unlimited Subject Category: 20 Available electronically at <a href="http://gltrs.grc.nasa.gov">http://gltrs.grc.nasa.gov</a> This publication is available from the NASA Center for AeroSpace Information, 301-621-0390					
<b>13. SUPPLEMENTARY NOTES</b>					
<b>14. ABSTRACT</b> This paper presents an overview of an affordable Fission Surface Power (FSP) system that could be used for NASA applications on the Moon and Mars. The proposed FSP system uses a low temperature, uranium dioxide-fueled, liquid metal-cooled fission reactor coupled to free-piston Stirling converters. The concept was determined by a 12 month NASA/DOE study that examined design options and development strategies based on affordability and risk. The system is considered a low development risk based on the use of terrestrial-derived reactor technology, high efficiency power conversion, and conventional materials. The low-risk approach was selected over other options that could offer higher performance and/or lower mass.					
<b>15. SUBJECT TERMS</b> Nuclear electric power generation					
<b>16. SECURITY CLASSIFICATION OF:</b>			<b>17. LIMITATION OF ABSTRACT</b>	<b>18. NUMBER OF PAGES</b>	<b>19a. NAME OF RESPONSIBLE PERSON</b>
<b>a. REPORT</b>	<b>b. ABSTRACT</b>	<b>c. THIS PAGE</b>			<b>19b. TELEPHONE NUMBER (include area code)</b>
U	U	U	UU	17	STI Help Desk (email:help@sti.nasa.gov) 301-621-0390





