

## **T1/ST2-deficient Mice Demonstrate the Importance of T1/ST2 in Developing Primary T Helper Cell Type 2 Responses**

By Michael J. Townsend,\* Padraic G. Fallon,<sup>‡</sup> David J. Matthews,\* Helen E. Jolin,\* and Andrew N.J. McKenzie\*

---

From the \*Medical Research Council Laboratory of Molecular Biology, Cambridge CB2 2QH, United Kingdom; and the <sup>‡</sup>Department of Pathology, University of Cambridge, Cambridge CB2 1QP, United Kingdom

### **Abstract**

We have generated mice with a deficiency in T1/ST2 expression to clarify the roles of T1/ST2 in T helper cell type 2 (Th2) responses. Using immunological challenges normally characterized by a Th2-like response, we have compared the responses of T1/ST2-deficient mice with those generated by wild-type mice. Using a primary pulmonary granuloma model, induced with *Schistosoma mansoni* eggs, we demonstrate that granuloma formation, characterized by eosinophil infiltration, is abrogated in T1/ST2-deficient mice. Furthermore, we clearly demonstrate that in the absence of T1/ST2 expression, the levels of Th2 cytokine production are severely impaired after immunization. Thus, in a secondary pulmonary granuloma model, draining lymph node cells from the T1/ST2-deficient animals produced significantly reduced levels of IL-4 and IL-5, despite developing granulomas of a magnitude similar to those of wild-type mice and comparable antigen-specific immunoglobulin isotype production. These data clearly demonstrate that T1/ST2 expression plays a role in the development of Th2-like cytokine responses and indicate that effector functions are inhibited in its absence.

Key words: T1/ST2 • T helper type 2 cells • immunoglobulin • pulmonary inflammation • mast cells

### **Introduction**

Although Th2 cells (characterized by their expression of cytokines such as IL-4, IL-5, IL-6, IL-9, IL-10, and IL-13) mediate beneficial responses to infection with parasitic gastrointestinal nematodes (1, 2), they have been shown to be detrimental in the development of asthma and allergy (3, 4). These effects are due to Th2 cells initiating responses including increased production of IgE and eosinophilia (5, 6). Recently, the IL-1 receptor-related molecule T1/ST2 has been reported to distinguish a subset of CD4<sup>+</sup> T helper cells of the Th2 subtype, characterized by their elevated expression of the cytokines IL-4, IL-5, and IL-13 (7–9). However, the T1/ST2 receptor is also expressed on mast cells (10, 11) and was described originally as a serum-induced gene in fibroblasts (12–15). Alternative transcriptional regulation results in the production of soluble and transmembrane forms of the T1/ST2 protein due to the use of different polyadenylation signals (16, 17). The

mRNA encoding the soluble form is induced upon stimulation of fibroblasts (12–15), whereas mRNA encoding the membrane-anchored form is expressed in the hematopoietic tissues and lung (16, 18). The T1/ST2 gene is tightly linked to the genes encoding the type I and type II IL-1 receptor on mouse chromosome 1 (19) and human chromosome 2 (20, 21). The biological function of the T1/ST2 receptor remains unclear, but its homology with Toll receptors and other IL-1 family members (22) suggests that it may play a central role in innate and adaptive immune responses.

Indeed, recent studies have suggested that administration of a neutralizing antibody against T1/ST2 or a T1/ST2-Ig fusion protein is capable of partially inhibiting Th2 cell differentiation and the development of Th2 effector functions in vivo, including allergic airway inflammation (7, 8, 23). However, a further study using a line of T1/ST2-deficient animals has suggested that T1/ST2 is not necessary for Th2 cell differentiation or effector function (24). Using parasitic infection with the helminth *Nippostrongylus braziliensis*, these investigators failed to show differences in IL-4 pro-

---

Address correspondence to Andrew N.J. McKenzie, MRC Laboratory of Molecular Biology, Hills Rd., Cambridge, CB2 2QH, UK. Phone: 44-1223-402350; Fax: 44-1223-412178; E-mail: anm@mrc-lmb.cam.ac.uk

duction from polyclonally activated splenocytes or changes in total serum IgE or IgG1 (24). Similarly, they also found that total serum IgE and IgG1 and immune cell phenotypes were normal in a model of airway inflammation (24). Thus, there appears to be a contradiction between the results obtained using T1/ST2 blocking reagents and those generated using T1/ST2-deficient animals.

We now demonstrate using a novel line of T1/ST2-deficient mice that although T1/ST2 does not appear to play an observable role in the generation of Th2 cytokines or Igs in naive animals, its presence can significantly affect the onset of Th2 cytokine responses to antigenic challenge. Using a model of pulmonary granuloma formation, we show that the onset of primary lung granuloma formation is severely inhibited in T1/ST2-deficient mice. In addition, Th2 cytokine production by the draining lymph nodes during secondary granuloma development is dramatically reduced, although after presensitization, granuloma morphology is normal, as is the induction of antigen-specific Ig isotype responses.

## Materials and Methods

**Targeted Disruption of the Mouse T1/ST2 Gene in Embryonic Stem Cells.** The replacement vector was constructed to insert the neomycin resistance gene between an engineered XbaI site in exon 4 and an engineered BamHI site in exon 5 of the T1/ST2 gene, thereby deleting the majority of exons 4 and 5. The targeting vector consisted of 5.1 kb of the T1/ST2 gene, providing the 5' arm of homology, and 2 kb comprising the 3' arm of homology. The arms of homology were generated by long-range PCR, using Pfu turbo polymerase (Stratagene) to prime from a lambda phage containing the 5' end of the T1/ST2 gene ( $\lambda$ ST2 including exons 1–7). The 5' arm of homology was generated using the oligonucleotides 5'-AGTGCATCTAGAGATACTGATGAGGC-ACC and 5'-CTTCTTTCTAGATTATTCAAGTTGGGGC-TATTTAAAGAAGCC, and the 3' arm of homology was created using the oligonucleotides 5'-CCACCGATCCTTCACAGT-TGAAGGTAAGCTCTTGGCTTCAACAAGGG and 5'-GGA-AGGAAAAAGCGGCCGCGATCTCGCTCCACAGAGATG-AGGAACGGCC. The targeting vector was linearized and electroporated into E14.1 embryonic stem (ES) cells (25). Of 1,600 G418-resistant clones screened by Southern analysis using probe A, 5 were targeted correctly. Probe A (184 bp) was generated using the PCR primers 5'-TACGTAACCTCCCATGTG-CAGTCCTTGCTGCC and 5'-GTCACATCACAGGCATGAGGG. Hybridization with a probe to the neomycin sequence confirmed the predicted size of the targeted fragment and that only a single integration had occurred. Two of the targeted ES cell clones were microinjected into 3.5-d C57BL/6 blastocysts to generate chimaeras. These mice were mated with C57BL/6 mice and transmitted the ES cell genotype through the germline. Mice homozygous for the disrupted T1/ST2 gene were obtained by interbreeding the heterozygotes. The T1/ST2 gene-targeted and wild-type animals used in the experiments reported below were maintained on a 129  $\times$  C57BL/6 (F<sub>2</sub>) background in a specific pathogen-free environment.

**In Vitro Th Cell Differentiation Assays.** Splenocytes or mesenteric lymph node cells were cultured on anti-CD3 $\epsilon$  antibody-coated plates (1  $\mu$ g/ml of clone 2C11; Becton Dickinson) in the presence of exogenous cytokines or anticytokine antibody as indi-

cated. IL-2 (10 ng/ml; R & D Systems, Inc.) was added to all cultures. Th2 cell differentiation was promoted in the presence of 100 ng/ml of IL-4 (R & D Systems, Inc.) and anti-IFN- $\gamma$  antibody (10  $\mu$ g/ml of clone XMG1.2; Becton Dickinson), and Th1 differentiation was promoted by anti-IL-4 antibody at 10  $\mu$ g/ml (clone 11B11; DNAX Research Institute) and IL-12 (1 ng/ml; Genzyme Corp.). Cells were cultured for 5 d, washed, and resuspended at 10<sup>6</sup> cells per milliliter for 24 h in the presence of plate-bound anti-CD3. Supernatants were analyzed by cytokine ELISA.

**Pulmonary Granuloma Formation.** Primary synchronous pulmonary granulomas were induced by intravenous injection of mice with *Schistosoma mansoni* eggs (26). *S. mansoni* eggs were isolated from the livers of infected mice as described (27). 11 d after intravenous egg injection, mice were killed, and the lungs were inflated with formal saline and processed for histology. The horizontal and perpendicular diameters of the granulomas surrounding individual eggs were measured with an ocular micrometer. All sections were measured by the same individual using a blind protocol. The volume of the egg granuloma was calculated assuming a spherical shape. Greater than 100 individual granulomas were analyzed per group.

Secondary synchronous pulmonary granulomas were induced as follows. Mice were sensitized to schistosome eggs by intraperitoneal injection of 5,000 eggs. 11 d later, sensitized mice, four to five mice per group, were injected intravenously with 5,000 eggs to induce synchronous pulmonary granulomas. 11 d after intravenous egg injection, mice were killed, and the draining mediastinal lymph nodes were removed. The lungs were processed for histology as described above. Cells were prepared from pooled mediastinal lymph nodes from each group and processed for cell culture as described (27). 3  $\times$  10<sup>6</sup> cells per milliliter were cultured and restimulated with 10  $\mu$ g/ml of soluble egg antigen or anti-CD3 mAb for 72 h. Cytokines were assayed in supernatants using ELISA. Serum samples were assayed for schistosome antigen-specific Ig isotypes as detailed below. Statistical analysis was performed using ANOVA (analysis of variance) and a Dunnett test.  $P < 0.05$  was considered significant.

**Total Serum Antibody ELISA.** Serum Igs were assayed using sandwich ELISA. 96-well plates were coated with monoclonal anti-Ig isotype capture antibodies, and bound Ig of diluted serum samples was detected using biotinylated monoclonal anti-Ig isotype detection antibodies (Becton Dickinson). Concentrations were calculated using purified Ig isotypes as standards (Becton Dickinson).

**Antigen-specific Antibody ELISA.** With the exception of antigen-specific IgE, schistosome egg antigen-specific isotype responses were measured using ELISA by coating 96-well plates with soluble egg antigen at 5  $\mu$ g/ml; bound Ig of diluted serum samples was detected using biotinylated monoclonal anti-Ig isotype detection antibodies (Becton Dickinson). Schistosome egg antigen specific serum IgE was determined using a two-step sandwich ELISA based on the method of van Halteren et al. (28). ELISA plates were coated at 2  $\mu$ g/ml with an anti-mouse IgE mAb (clone R35-72; PharMingen). Serum samples were added and the plates incubated for 1 h at room temperature. After washing, digoxigenin (DIG)-coupled soluble egg antigen, prepared from a kit containing DIG-3-O-methylcarbonyl- $\epsilon$ -amino caproic acid *N*-hydroxy-succinimide ester (Boehringer Mannheim) was added and incubated for 1 h at room temperature. After washing, anti-DIG-Fab fragments coupled to peroxidase (Boehringer Mannheim) were used to detect bound antibody.

**Cytokine ELISA.** Cytokine ELISA also used the sandwich format with capture and detection antibodies purchased from

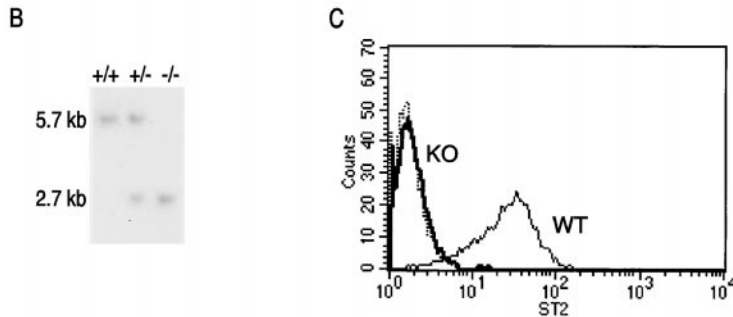
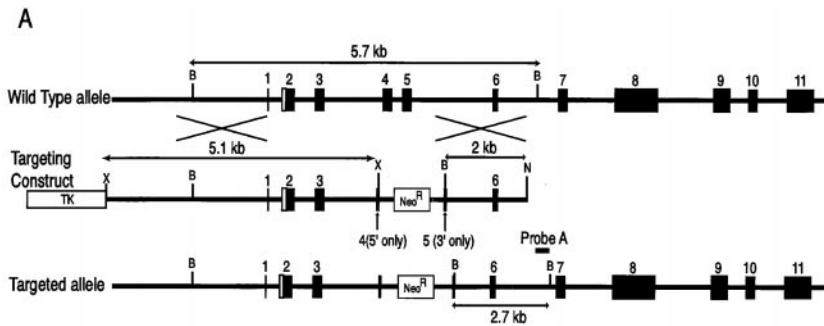

**Figure 1.** Inactivation of the T1/ST2 gene by homologous recombination. (A) The structure of the T1/ST2 locus, the targeting vector, and the predicted homologous recombination event are shown. Targeted disruption results in the deletion of the majority of exons 4 and 5. Neo<sup>R</sup>, neomycin resistance cassette; TK, thymidine kinase cassette; B, BamHI; X, XbaI; N, NotI. Intron-exon boundaries are inferred from the rat gene sequence (16). (B) Southern blot of F<sub>2</sub> tail genomic DNA. The indicated probe detects a 5.7-kb BamHI fragment in the wild-type T1/ST2 gene and a 2.7-kb fragment as a result of the correct homologous recombination event. (C) Analysis of T1/ST2 expression by mast cells. Mast cells were cultured from bone marrow in the presence of IL-3 and stem cell factor. Biotinylated anti-T1/ST2 (DJ8) was used to stain for T1/ST2 expression.

Becton Dickinson. ELISAs were performed according to Becton Dickinson ELISA protocol.

**Mast Cell Preparation.** Bone marrow was aseptically flushed from femora and tibiae of 8-wk-old mice. The cell suspension was cultured at  $4 \times 10^5$  cells per milliliter in the presence of 5 ng/ml of IL-3 and 10% WEHI-3B conditioned supernatant for 3–4 wk, with media changes every 7 d. The resultant cell populations were 95% c-kit<sup>+</sup> and Gr-1<sup>+</sup> when analyzed by flow cytometry (PharMingen). Mast cells were stained using the biotinylated anti-T1/ST2 mAb DJ8 (11).

**Eosinophil Peroxidase Assay for Lung Tissue Eosinophilia.** Tissue eosinophilia was determined using the eosinophil peroxidase assay (29). The numbers of eosinophils (expressed as  $10^6$  per gram of tissue) were interpolated from a standard curve prepared from eosinophils purified from the blood of *N. braziliensis*-infected mice.

## Results and Discussion

**Generation of T1/ST2-deficient Mice.** The targeting vector was designed to delete the majority of exons 4 and 5 and replace them with the neomycin resistance cassette after homologous recombination (Fig. 1 A). These exons constitute part of the extracellular portion of the T1/ST2 receptor and are common to both the membrane-bound and soluble forms of the protein (15). Genotyping of wild-type (T1/ST2<sup>+/+</sup>), heterozygous (T1/ST2<sup>+/-</sup>), and homozygous null (T1/ST2<sup>-/-</sup>) mice is shown in Fig. 1 B. The T1/ST2<sup>-/-</sup> mice were healthy and displayed no overt phenotypic abnormalities. Analysis of the T1/ST2<sup>-/-</sup> mice failed to detect T1/ST2 RNA transcripts from activated lymphocytes using reverse transcriptase-PCR assays (data not shown), and flow cytometry also failed to identify T1/ST2 protein on the surfaces of cultured mast cells (Fig. 1 C)

or CD4<sup>+</sup> T cells from spleen or lymph node (data not shown). Naive animals were examined to determine the effects of T1/ST2 disruption on the immune system. Furthermore, we also assessed the immune responses of the T1/ST2<sup>-/-</sup> animals to immunological challenges that normally provoke a Th2 phenotype.

**Naive Immune Cell Populations, Cytokine Levels, Th1 and Th2 Cell Development, and Total Ig Isotype Production Are Normal in T1/ST2<sup>-/-</sup> Mice.** Flow cytometric analysis of cells derived from naive T1/ST2-deficient and wild-type animals failed to show differences in the cell surface expression of CD4, CD8, TCR, CD3, CD5, CD25, CD45, and

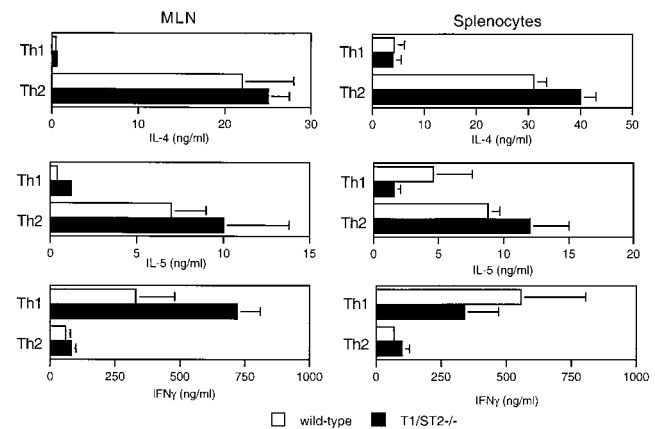

**Figure 2.** Analysis of naive T helper cell differentiation. Cytokine production after *in vitro* Th cell differentiation. Mesenteric lymph node cells or splenocytes from three wild-type or three IL-13<sup>-/-</sup> mice were stimulated under Th1 or Th2 culture conditions for 5 d, washed, and restimulated on anti-CD3 antibody-coated plates for 24 h. Supernatants were analyzed by ELISA. Data are representative of three repeat experiments.

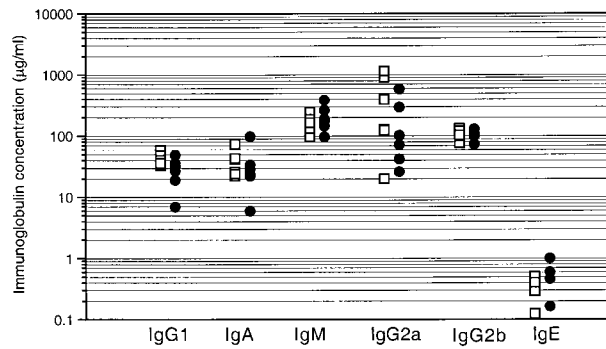

**Figure 3.** Total serum Ig isotype production from naive wild-type (□) and T1/ST2<sup>-/-</sup> (●) mice. Represented data points indicate individual animals.

Gr-1 on thymocytes; CD4, CD8, TCR, CD3, CD5, CD14, CD23, CD45, Gr-1, CD11b, and TER119 on mesenteric lymph node cells or splenocytes; CD3, CD5, CD14, CD23, CD24, CD43, CD45, Gr-1, CD11b, TER119, BP1, and c-kit on bone marrow; and CD5, CD45, CD11b, c-kit, and Gr-1 on peritoneal lavage (data not shown).

Stimulation of mesenteric lymph node cells or splenocytes from naive animals with polyclonal activators of T

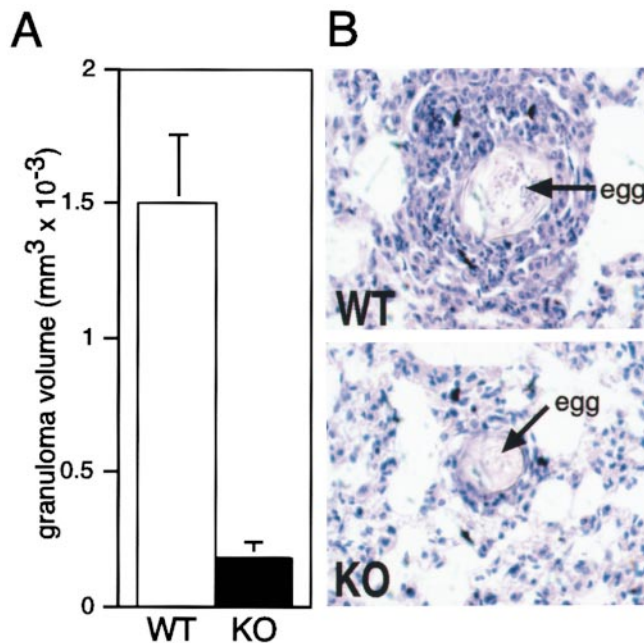

**Figure 4.** Analysis of primary pulmonary inflammatory response. (A) Determination of granuloma volumes in immunized mice. Cohorts of four to five mice were injected intravenously with 5,000 schistosoma eggs to induce synchronous pulmonary granuloma. Mice were killed 11 d later. Lung sections were stained with hematoxylin and eosin, and at least 100 individual granulomas were measured per group. Data are presented as means less egg volumes plus SD. (B) Morphological analysis of granuloma formation in wild-type (WT) and T1/ST2<sup>-/-</sup> (KO) mice. Lung sections were stained with hematoxylin and eosin. Magnification, 63. Data are representative of two repeat experiments.

cells demonstrated that IL-4, IL-5, IL-10, and IFN- $\gamma$  production from these cellular pools was not altered by the absence of the T1/ST2 receptor (data not shown). Furthermore, when lymph node cells or splenocytes were cultured in vitro under conditions that promote the differentiation of Th1 or Th2 cells, no significant differences were observed in these lineages from cultures derived from T1/ST2-deficient or wild-type animals (Fig. 2). Polyclonal activation of cultured mast cell populations from wild-type and T1/ST2-deficient animals also failed to identify a difference in cytokine production (data not shown). In addition, total serum Ig isotype responses from naive T1/ST2<sup>-/-</sup> mice were also comparable to those detected in wild-type animals (Fig. 3). Thus, the absence of T1/ST2 expression does not appear to have compromised the basal immune functions of the T1/ST2<sup>-/-</sup> mice. These results imply that the cell surface expression of T1/ST2 is not necessary for immune competence in naive animals that are not undergoing immune challenge. Our in vitro T cell differentiation data also demonstrate that expression of T1/ST2 is not critical for the development of naive T cells toward a Th2

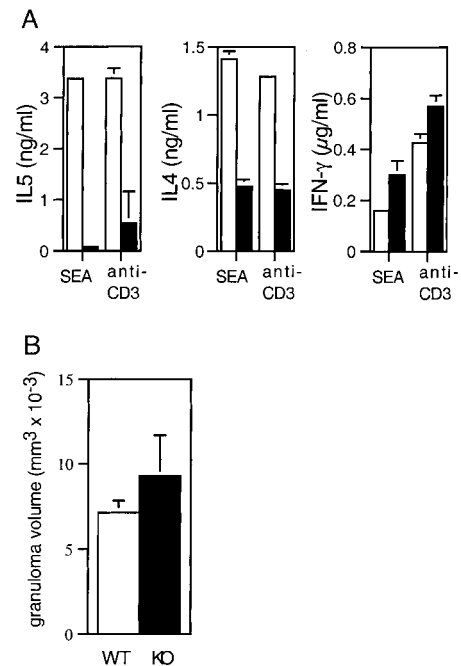

**Figure 5.** Analysis of presensitized pulmonary inflammatory response. Cohorts of four to five mice were sensitized by intraperitoneal injection of 5,000 *S. mansoni* eggs. After 11 d, these mice were injected intravenously with 5,000 eggs to induce synchronous pulmonary granuloma. Mice were killed 11 d later. (A) Cytokine responses to pulmonary challenge. Cytokine responses from activated lymph node cells. Draining mediastinal lymph node cells were stimulated with soluble egg antigen or anti-CD3 antibody, and supernatants were assayed for cytokines by ELISA. Data are presented as means plus SD. Open bars, wild-types; filled bars, ST2<sup>-/-</sup>. (B) Determination of granuloma volumes in sensitized mice. Lung sections were stained with hematoxylin and eosin, and at least 100 individual granulomas were measured per group. Data are presented as means less egg volumes plus SD and are representative of two repeat experiments. WT, wild-type; KO, knockout.

phenotype. However, to address whether the T1/ST2 molecule mediates demonstrable effects during Th2 immune responses, we challenged the T1/ST2-deficient mice with antigens known to induce Th2 responses.

**Induction of Primary Synchronous Pulmonary Granuloma Formation using *S. mansoni* Eggs Is Severely Impaired in T1/ST2-deficient Animals.** To determine the *in vivo* contribution of T1/ST2 in a Th2 cytokine-mediated inflammatory response, we employed a model system in which synchronous pulmonary granuloma formation is induced around *S. mansoni* eggs (30). In this model, a cellular granulomatous response develops around parasite eggs that lodge in the lungs after their intravenous injection into mice. This inflammatory response is characterized by the high-level expression of Th2 cytokines (31) and the infiltration of eosinophils (30). This model has proven extremely valuable in defining the respective effector functions of cytokines involved in this Th2 response (30) and has the advantage of generating a quantifiable inflammatory cell infiltrate even during the primary response to antigen.

After intravenous injection of naive wild-type mice with schistosome eggs, granuloma formation was detected as expected (Fig. 4 A) and consisted of eosinophil infiltration around the immobilized eggs (Fig. 4 B). In sharp contrast, naive T1/ST2-deficient mice failed to develop significant pulmonary granuloma formation in response to intravenous administration of schistosome eggs (Fig. 4 A), and eosinophilic infiltration was not detected (Fig. 4 B). Quantification of eosinophil numbers in the lungs using the eosinophil peroxidase assay clearly demonstrated a 10-fold reduction in this cell type in the T1/ST2-deficient animals (wild-type  $38.4 \pm \text{SE } 5.6$  versus T1/ST2<sup>-/-</sup>  $3.4 \pm \text{SE } 0.7$  [ $P = 0.0035$ ], defined as eosinophils  $\times 10^6$  per gram). Thus, the primary pulmonary granulomatous model demonstrates that mice deficient in T1/ST2 expres-

sion have a severe impairment in their ability to generate this stereotypical Th2-like inflammatory response.

**Th2 Cytokine Production in Response to Secondary Pulmonary Granuloma Formation Is Impaired in T1/ST2-deficient Mice, but Secondary Granulomas Are Normal.** We have also assessed the effect of presensitizing T1/ST2<sup>-/-</sup> and wild-type animals to egg antigens before the intravenous administration of eggs. These animals were given a primary administration of schistosome eggs intraperitoneally before being challenged with an intravenous inoculation of schistosome eggs. The lungs were then examined for the development of granulomas, and the mediastinal lymph nodes draining the lungs were analyzed for cytokine expression. Significantly, the egg antigen-specific and polyclonally induced cytokine responses generated from the draining mediastinal lymph nodes demonstrate that T1/ST2<sup>-/-</sup> mice are significantly impaired in their ability to generate the Th2 cytokines IL-4 and IL-5 but not IFN- $\gamma$  (Fig. 5 A). However, after presensitization, both the wild-type and T1/ST2-deficient mice generated secondary pulmonary granulomas of comparable magnitude (Fig. 5 B) and cell composition (data not shown). Furthermore, both wild-type and T1/ST2<sup>-/-</sup> mice developed similar egg antigen-specific Ig isotype responses to immunization after secondary priming despite the differences in cytokine expression (Fig. 6). In contrast to the effects observed in naive T1/ST2-deficient animals, these results demonstrate that T1/ST2 expression is critically required for the unimpaired development of a Th2 cytokine response. However, it is also clear that after sensitization, T1/ST2<sup>-/-</sup> animals can still generate a normal granuloma response despite producing significantly reduced levels of Th2 cytokines. These data contrast with the results obtained using the primary granuloma model and imply that the effects of ablating T1/ST2 expression can be circumvented by alternative pathways after priming of the immune response.

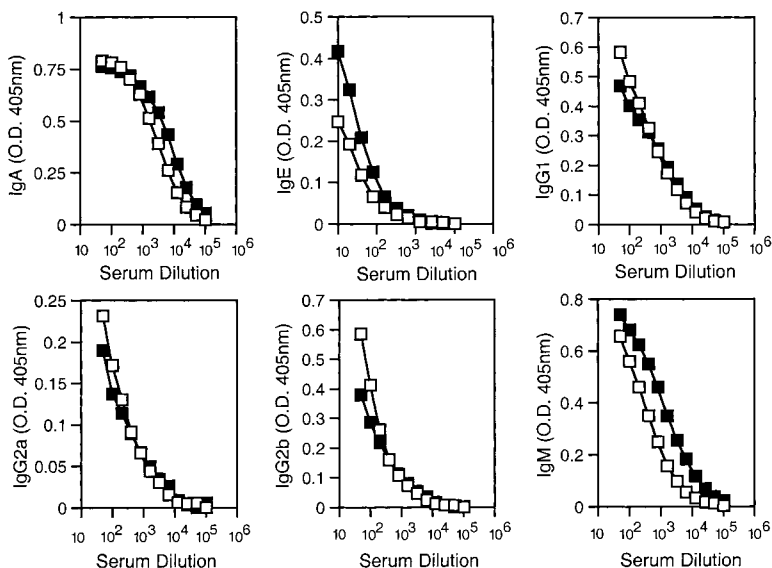

**Figure 6.** Antigen-specific Ig response to immunization. Cohorts of four to five animals were immunized intraperitoneally with schistosome eggs, followed by secondary administration of eggs intravenously. □, wild-type; ■, T1/ST2<sup>-/-</sup>. Serum samples were assayed 11 d after the secondary antigen challenge by ELISA for Ig isotypes. Representative data from two repeat experiments are shown.

Using T1/ST2-deficient mice, we clearly demonstrate a significant role for this molecule in the generation of Th2 cytokine responses to antigen challenge in the lung. Particularly striking was the reduction in lung tissue eosinophilia in T1/ST2<sup>-/-</sup> mice after primary granuloma formation. It is noteworthy that although a reduction in Th2 cytokine production was observed after secondary antigen challenges, only primary granuloma formation was significantly impaired. These data suggest that although T1/ST2 plays a key role in the early events involved in the generation of Th2 immune reactions, its presence is not essential for the generation of downstream effector functions and may be bypassed by alternative mechanisms. However, it is also apparent that in the absence of T1/ST2, the immune response to lung damage is significantly delayed and might constitute a selective disadvantage in a less protective environment.

It is interesting that certain of our results appear to contradict those of Hoshino et al. (24), who have also studied T1/ST2-deficient mice. Although we agree that the presence of T1/ST2 is not necessary for the differentiation of Th2 cells under in vitro culture conditions, we find antigen-specific Th2 cytokine responses and effector function are impaired in our T1/ST2<sup>-/-</sup> mice. It is noteworthy that our results are supported by data from studies using reagents that inhibit T1/ST2 function (7, 8, 23). It is possible that our use of short-term antigen challenge, route of administration, and antigen-specific restimulation has unmasked phenotypic differences that are obscured by the multiple immunization protocol and polyclonal activation used by Hoshino et al. (24). Although molecules that interact with the T1/ST2 receptor have been reported (9, 32), the cognate ligand has yet to be identified but would appear to be an important molecule in the initiation of Th2 immune responses. In conclusion, our study demonstrates that T1/ST2 does play a functional role in the generation of Th2 cytokine responses in vivo and that inhibiting its function, in combination with inhibiting molecules such as IL-4, IL-5, and IL-13, may offer a route for controlling the development of atopy.

The authors would like to thank Sarah Bell for critical reading of this manuscript and Emma Richardson, Philip Smith, and the MRC SABU staff for technical assistance. We acknowledge Roman Klemenz (Zurich) for providing the anti-T1/ST2 antibody DJ8 and Fiona Culley for assistance with the eosinophil peroxidase assay.

P.G. Fallon is supported by a Wellcome Trust Career Development Award.

Submitted: 2 December 1999

Accepted: 7 January 2000

Released online: 20 March 2000

## References

- Finkelman, F., T. Shea-Donohue, J. Goldhill, C. Sullivan, S. Morris, K. Madden, W. Gause, and J. Urban. 1997. Cytokine regulation of host defence against parasitic gastrointestinal nematodes: lessons from studies with rodent models. *Annu. Rev. Immunol.* 15:505–533.
- McKenzie, G., A. Bancroft, R. Grencis, and A. McKenzie. 1998. A distinct role for interleukin-13 in Th2-cell-mediated immune responses. *Curr. Biol.* 8:339–342.
- Foster, P., S. Hogan, A. Ramsay, K. Matthei, and I. Young. 1996. Interleukin-5 deficiency abolishes eosinophilia, airways hyperreactivity and lung damage in a mouse asthma model. *J. Exp. Med.* 183:195–201.
- Wills-Karp, M., J. Luyimbazi, X. Xu, B. Schofield, T.Y. Neben, C.L. Karp, and D.D. Donaldson. 1998. Interleukin-13: central mediator of allergic asthma. *Science.* 282:2258–2261.
- Finkelman, F., J. Urban, P. Beckmann, K. Schooley, J. Holmes, and I. Katona. 1991. Regulation of murine in vivo IgG and IgE responses by a monoclonal anti-IL-4 receptor antibody. *Int. Immunol.* 3:599–607.
- Sanderson, C.J. 1992. IL-5, eosinophils, and disease. *Blood.* 79:3101–3109.
- Xu, D., W.L. Chan, B.P. Leung, F.P. Huang, R. Wheeler, D. Piedrafita, J.H. Robinson, and F.Y. Liew. 1998. Selective expression of stable surface molecule on type 2 but not type 1 helper T cells. *J. Exp. Med.* 187:787–794.
- Lohning, M., A. Stroehmann, A.J. Coyle, J.L. Grogan, S. Lin, J.C. Gutierrez-Ramos, D. Levinson, A. Radbruch, and T. Kamradt. 1998. T1/ST2 is preferentially expressed on murine Th2 cells, independent of interleukin 4, interleukin 5, and interleukin 10, and important for Th2 effector function. *Proc. Natl. Acad. Sci. USA.* 95:6930–6935.
- Yanagisawa, K., Y. Naito, K. Kuroiwa, T. Arai, Y. Furukawa, H. Tomizuka, Y. Miura, T. Kasahara, T. Tetsuka, and S. Tominaga. 1997. The expression of ST2 gene in helper T cells and the binding of ST2 protein to myeloma-derived RPMI8226 cells. *J. Biochem.* 121:95–103.
- Moritz, D.R., H.R. Rodewald, J. Gheyselinck, and R. Klemenz. 1998. The IL-1 receptor-related T1 antigen is expressed on immature and mature mast cells and on fetal blood mast cell progenitors. *J. Immunol.* 161:4866–4874.
- Moritz, D.R., J. Gheyselinck, and R. Klemenz. 1998. Expression analysis of the soluble and membrane-associated forms of the interleukin-1 receptor-related T1 protein in primary mast cells and fibroblasts. *Hybridoma.* 17:107–116.
- Tominaga, S. 1989. A putative protein of a growth specific cDNA from BALB/c-3T3 cells is highly similar to the extracellular portion of mouse interleukin-1 receptor. *FEBS Lett.* 258:301–304.
- Klemenz, R., S. Hoffmann, and A.-E. Werenskiold. 1989. Serum- and oncoprotein-mediated induction of a gene with sequence similarity to the gene encoding carcinoembryonic antigen. *Proc. Natl. Acad. Sci. USA.* 86:5708–5712.
- Yanagisawa, K., T. Tsukamoto, T. Takagi, and S. Tominaga. 1992. Murine ST2 gene is a member of the primary response gene family induced by growth factors. *FEBS Lett.* 302:51–53.
- Yanagisawa, K., T. Takagi, T. Tsukamoto, T. Tetsuka, and S. Tominaga. 1993. Presence of a novel primary response gene ST2L, encoding a product highly similar to the interleukin 1 receptor type 1. *FEBS Lett.* 318:83–87.
- Bergers, G., A. Reikerstorfer, S. Braselmann, P. Graninger, and M. Busslinger. 1994. Alternative promoter usage of the Fos-responsive gene Fit-1 generates mRNA isoforms coding for either secreted or membrane-bound proteins related to the IL-1 receptor. *EMBO (Eur. Mol. Biol. Organ.) J.* 13:

- 1176–1188.
17. Gachter, T., D.R. Moritz, J. Gheyselinck, and R. Klemenz. 1998. GATA-dependent expression of the interleukin-1 receptor-related T1 gene in mast cells. *Mol. Cell. Biol.* 18: 5320–5331.
  18. Rossler, U., E. Thomassen, L. Hultner, S. Baier, J. Danescu, and A.K. Werenskiold. 1995. Secreted and membrane-bound isoforms of T1, an orphan receptor related to IL-1-binding proteins, are differently expressed in vivo. *Dev. Biol.* 168:86–97.
  19. Tominaga, S., N.A. Jenkins, D.J. Gilbert, N.G. Copeland, and T. Tetsuka. 1991. Molecular cloning of the murine ST2 gene. Characterization and chromosomal mapping. *Biochim. Biophys. Acta.* 1090:1–8.
  20. Tominaga, S., J. Inazawa, and S. Tsuji. 1996. Assignment of the human ST2 gene to chromosome 2 at q11.2. *Hum. Genet.* 97:561–563.
  21. Dale, M., and M.J. Nicklin. 1999. Interleukin-1 receptor cluster: gene organization of IL1R2, IL1R1, IL1RL2 (IL-1Rrp2), IL1RL1 (T1/ST2), and IL18R1 (IL-1Rrp) on human chromosome 2q. *Genomics.* 57:177–179.
  22. Mitcham, J.L., P. Parnet, T.P. Bonnert, K.E. Garka, M.J. Gerhart, J.L. Slack, M.A. Gayle, S.K. Dower, and J.E. Sims. 1996. T1/ST2 signaling establishes it as a member of an expanding interleukin-1 receptor family. *J. Biol. Chem.* 271: 5777–5783.
  23. Coyle, A.J., C. Lloyd, J. Tian, T. Nguyen, C. Eriksson, L. Wang, P. Ottoson, P. Persson, T. Delaney, S. Lehar, et al. 1999. Crucial role of the interleukin 1 receptor family member T1/ST2 in T helper cell type 2-mediated lung mucosal immune responses. *J. Exp. Med.* 190:895–902.
  24. Hoshino, K., S. Kashiwamura, K. Kuribayashi, T. Kodama, T. Tsujimura, K. Nakanishi, T. Matsuyama, K. Takeda, and S. Akira. 1999. The absence of interleukin 1 receptor-related T1/ST2 does not affect T helper cell type 2 development and its effector function. *J. Exp. Med.* 190:1541–1547.
  25. McKenzie, G.J., C.L. Emson, S.E. Bell, S. Anderson, P. Fallon, G. Zurawski, R. Murray, and A.N.J. McKenzie. 1998. Impaired development of Th2 cells in IL-13-deficient mice. *Immunity.* 9:423–432.
  26. Warren, K.S., and E.O. Domingo. 1970. Granuloma formation around *Schistosoma mansoni*, *S. haematobium*, and *S. japonicum* eggs. *Am. J. Trop. Med. Hyg.* 19:291–304.
  27. Fallon, P.G., P. Smith, and D.W. Dunne. 1998. Type 1 and type 2 cytokine-producing mouse CD4+ and CD8+ T cells in acute *Schistosoma mansoni* infection. *Eur. J. Immunol.* 28: 1408–1416.
  28. van Halteren, A.G.S., M.J.F. van der Cammen, J. Biewenga, H.F.J. Savelkoul, and G. Krall. 1997. IgE and mast cell responses on intestinal allergen exposure: a murine model to study the onset of food allergy. *J. Allergy Clin. Immunol.* 99: 94–99.
  29. Strath, M., D.J. Warren, and C.J. Sanderson. 1985. Detection of eosinophils using an eosinophil peroxidase assay. Its use as an assay for eosinophil differentiation factors. *J. Immunol. Methods.* 83:209–215.
  30. McKenzie, G.J., P.G. Fallon, C.L. Emson, R.K. Grencis, and A.N.J. McKenzie. 1999. Simultaneous disruption of interleukin (IL)-4 and IL-13 defines individual roles in T helper cell type 2-mediated responses. *J. Exp. Med.* 189:1565–1572.
  31. Wynn, T.A., I. Eltoun, A.W. Cheever, F.A. Lewis, W.C. Gause, and A. Sher. 1993. Analysis of cytokine mRNA expression during primary granuloma formation induced by eggs of *Schistosoma mansoni*. *J. Immunol.* 151:1430–1440.
  32. Gayle, M.A., J.L. Slack, T.P. Bonnert, B.R. Renshaw, G. Sonoda, T. Taguchi, J.R. Testa, S.K. Dower, and J.E. Sims. 1996. Cloning of a putative ligand for the T1/ST2 receptor. *J. Biol. Chem.* 271:5784–5789.