

## REVIEW ARTICLE

---

### Table-top soft x-ray lasers

J. J. Rocca

*Electrical and Computer Engineering Department, Colorado State University, Fort Collins, Colorado 80523*

(Received 29 October 1998; accepted for publication 19 January 1999)

This article reviews the progress in the development of practical table-top sources of soft x-ray laser radiation. The field is rapidly approaching the stage at which soft x-ray lasers sufficiently compact to fit onto a normal optical table will be routinely utilized in science and technology. This is the result of recent advances in the amplification of soft x-ray radiation in both compact laser-pumped and discharge-pumped devices. The use of excitation mechanisms that take full advantage of new ultrafast high power optical laser drivers and multiple pulse excitation schemes has resulted in the demonstration of saturated soft x-ray amplification at wavelengths as short as 14 nm using several Joule of laser-pump energy. Moreover, several schemes have demonstrated significant gain with only a fraction of a Joule of laser-pump energy. In addition, the demonstration of saturated table-top soft x-ray lasers pumped by very compact capillary discharges has shattered the notion that discharge-created plasmas are insufficiently uniform to allow for soft x-ray amplification, opening a route for the development of efficient, high average power soft x-ray lasers. Recently, a table-top capillary discharge laser operating at 46.9 nm has produced millijoule-level laser pulses at a repetition rate of several Hz, with a corresponding spatially coherent average power per unit bandwidth comparable to that of a beam line at a third generation synchrotron facility. This review summarizes fundamental and technical aspects of table-top soft x-ray lasers based on the generation of population inversions in plasmas, and discusses the present status of development of specific laser systems. © 1999 American Institute of Physics. [S0034-6748(99)00110-0]

#### I. INTRODUCTION

Great progress has been achieved in the last several years in the development of very compact and practical soft x-ray lasers.<sup>1-4</sup> The field is rapidly approaching the stage at which soft x-ray lasers sufficiently compact to fit onto a normal optical table (frequently described as “table-top” lasers) will be routinely utilized in science and technology. The motivations for the development of table-top soft x-ray lasers are numerous. They include the characterization and processing of materials, very high resolution metrology, studies in atomic physics, photochemistry and photophysics, biological imaging, and the diagnostics of very high density plasmas. Practical table-top x-ray lasers will also open up exploration of completely new fields, such as nonlinear optics at ultrashort wavelengths. In the not very distant future, when their wavelength will drop below 1 nm, applications such as time-resolved x-ray diffractometry of biological and inorganic materials, and medical diagnostics with coherent x rays will also be realized. Moreover, several of the most important applications may yet be unforecasted. When novel practical sources of intense electromagnetic radiation were developed in the past, new regimes of physical parameters became accessible, often resulting in the observation of unexpected phenomena that led to important scientific and technologic breakthroughs. Based on such historical considerations, many researchers believe that the benefits of the widespread

availability of practical and affordable table-top x-ray lasers will impact numerous scientific disciplines and industries, even exceeding current predictions.

This review summarizes fundamental and technical aspects of the development of table-top soft x-ray lasers based on the generation of population inversions in plasmas. However, the direct amplification of radiation in plasmas is not the only means by which coherent soft x-ray radiation can be generated. Alternative methods include harmonic up-conversion of high power optical lasers,<sup>5-8</sup> synchrotron sources,<sup>9-11</sup> and free electron lasers (FELs).<sup>12,13</sup> Synchrotron sources have the very important advantages of broad tunability and high average power. In contrast, they fall short of the high peak brightness needed in applications such as the study of nonlinear phenomena at ultrashort wavelengths<sup>14</sup> and the diagnostics of dense plasmas.<sup>15,16</sup> Also, they are very large and expensive to construct. An alternative also based on accelerator technology is the use of self-amplified spontaneous emission in a FEL.<sup>12,13</sup> In a soft x-ray FEL, an electron beam would radiate at higher powers and with better coherence than it does due to spontaneous synchrotron radiation. Several single-pass ultrashort wavelength FELs have been proposed or are under construction.<sup>12</sup> Nevertheless, these lasers will not be table-top devices in the near future. Alternatively, soft x-ray coherent radiation can also be generated using either nonlinear optical techniques for frequency up-conversion of optical laser radiation, or by direct amplifica-

tion of spontaneous emission in a plasma. Very important progress has been achieved in the past several years in the generation of high order harmonics of intense ultrashort pulse optical lasers. Harmonic up-conversion in table-top laser systems has been reported to generate radiation at wavelengths as short as 2.7 nm.<sup>6</sup> Presently, fairly optimized conditions in nonphase matched configurations yield typically a conversion efficiency of about  $10^{-6}$  in the range of 10–40 eV (on the order of  $10^9$  photons per pulse) and  $10^{-8}$  in the 40–150 eV range ( $10^6$ – $10^7$  photons per pulse).<sup>5</sup> The highest energy reported for a high order harmonic pulse, 60 nJ at about 50 eV, was obtained using the second harmonic of a powerful glass laser.<sup>8</sup> Recently, the demonstration of phase-matched harmonic conversion of visible light into soft x rays with a generation efficiency of  $10^{-5}$ – $10^{-6}$  in the 40–70 eV spectral region<sup>7</sup> was reported. Soft x-ray pulses with an energy of  $>0.2$  nJ/pulse per harmonic order were produced at a repetition frequency of 1 kHz utilizing 20 fs optical pulses.<sup>7</sup> This recent development promises to result in soft x-ray pulses with a high peak brightness and high average power. Alternatively, table-top x-ray lasers have the advantage of a much higher energy per pulse, and the potential to produce x-ray beams with very high average power.<sup>17</sup> For example, at a photon energy of 26.5 eV, a very compact discharge pumped table-top soft x-ray laser has already produced output pulses with an average energy of 0.88 mJ ( $\approx 2 \times 10^{14}$  photons/pulse) at a repetition rate of 4 Hz, corresponding to an average output power of  $\approx 3.5$  mW.<sup>18</sup> Nevertheless, as different applications will require soft x-ray radiation with specific characteristics, in many cases the use of these various sources will be complementary. The focus of this article is table-top soft x-ray lasers. For a description of the characteristics and status of alternative methods for the generation of coherent soft x-ray radiation, the reader is referred to the literature.<sup>5–13</sup>

The quest for practical x-ray lasers started shortly after the demonstration of the first lasers in 1960.<sup>19</sup> Proposals of excitation schemes for x-ray lasers date back to 1965, when the possibility of achieving soft x-ray amplification by collisional recombination was first suggested by Gudzenko and Shelepin.<sup>20</sup> This was followed by proposals of photoionization pumping of x-ray lasers in 1967<sup>21</sup> and of electron impact excitation schemes.<sup>22–27</sup> The latter were inspired in part by the earlier success in the development of visible and ultraviolet ion lasers excited by electron collisions.<sup>28,29</sup> However, the dramatic scaling of the pump power requirements with decreasing wavelength and the low normal incidence reflectivity of bulk materials at soft x-ray wavelengths, combined with the short lifetime of the excited levels involved in the lasing process, made the realization of soft x-ray lasers a very challenging task. Several experiments realized during the 1970s and early 1980s yielded the observation of population inversions and gain.<sup>30–37</sup> Nevertheless, the experimental demonstration of large amplification at soft x-ray wavelengths was not realized until 1984, when Matthews *et al.*<sup>38</sup> and Suckewer *et al.*<sup>39</sup> observed amplification from the generation of population inversions in plasmas by collisional electron excitation and collisional electron–ion recombination, respectively. These pioneering demonstrations were

soon followed by numerous successful soft x-ray amplification experiments conducted using some of the world's most powerful lasers as pump sources.<sup>41–43</sup> Subsequent experiments achieved for the first time soft x-ray laser operation in the saturated regime,<sup>44–47</sup> and realized proof-of-principle demonstrations in several applications. These applications include microscopy,<sup>48,49</sup> holography,<sup>50</sup> diagnostics of dense plasmas,<sup>15,16</sup> and the excitation of nonlinear photoluminescence in crystals.<sup>51</sup> However, the large complexity, cost, and size of these lasers, and their low repetition rate, are barriers that limit their widespread utilization. It became clear that for soft x-ray lasers to be nearly as commonly used as optical lasers, the development of compact, low cost table-top soft x-ray amplifiers was required. Several articles have reviewed the progress in the development of x-ray lasers,<sup>52–57</sup> starting with Waynant and Elton in 1976.<sup>52</sup> The book by Elton discusses the developments up to 1990.<sup>58</sup> A detailed account of the progress realized since that time can be found in the proceedings of two biannual conferences that focus on the development and application of soft x-ray lasers.<sup>1–4,59–61</sup>

The next few years are likely to witness a dramatic increase in the use of soft x-ray lasers in applications as a result of the very rapid progress recently achieved in the development of compact pump sources, and the recent demonstration of large soft x-ray amplification in table-top systems. The advances in pump sources include the development of multiterawatt table-top optical laser systems based on chirped pulse amplification<sup>62–65</sup> and fast capillary discharges capable of generating highly ionized plasma columns with very high uniformity and length-to-diameter aspect ratios approaching 1000 to 1.<sup>66–70</sup> Also contributing to the progress towards practical table-top x-ray lasers is the achievement of very important reductions in the laser pump energy required for lasing,<sup>72–80</sup> to less than 1 J.<sup>72–75,80</sup> This is in part the result of the implementation of excitation mechanisms that take full advantage of the high intensity and short pulse width of new ultrashort pulse optical laser systems. Alternatively, the observation of large soft x-ray amplification in fast capillary discharge plasmas<sup>81–83</sup> has shattered the notion that discharge created plasmas are insufficiently uniform to allow for soft x-ray amplification, and has opened a new route for the development of very efficient high average power soft x-ray lasers. These recent developments, coupled to advances in soft x-ray optics<sup>84,85</sup> create the grounds for a promising future for table-top soft x-ray laser sources.

## II. REQUIREMENTS FOR SOFT X-RAY AMPLIFICATION IN PLASMAS

### A. Pump power requirements and scaling laws

For most efficient energy extraction from a laser media it is necessary to operate in a regime where gain saturation is achieved.<sup>86</sup> In most optical lasers the feedback provided by the optical cavity allows us to easily reach the light intensities at which the media is saturated. In contrast, the duration of the gain in soft x-ray lasers is usually shorter than the time required for the effective use of an optical cavity. This is the result of either the rapid self-terminated nature of the population inversion in transient schemes,<sup>74–78</sup> or the difficulty of

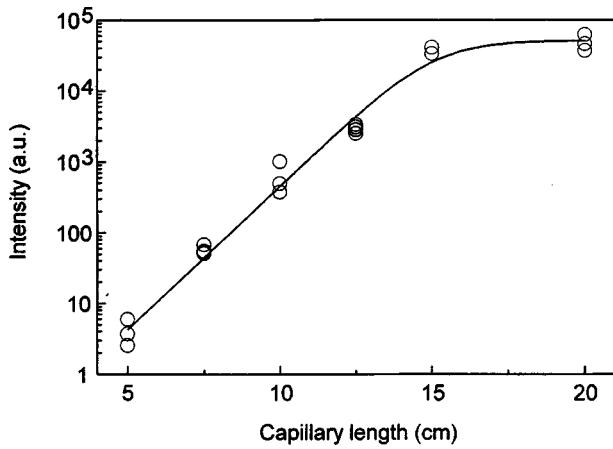

FIG. 1. Integrated intensity of the 46.9 nm line of Ne-like Ar as a function of plasma column length in a capillary discharge amplifier. The exponential increase of the intensity ceases at  $l=15$  cm, where the saturation intensity is reached (from Rocca *et al.*, Ref. 70).

maintaining for a sufficient period of time the stringent plasma conditions necessary for amplification in quasi-cw schemes.<sup>38–47,83</sup> Consequently, soft x-ray lasers normally operate with a single-pass or double-pass amplification of the spontaneous emission through the gain medium. In such amplified spontaneous emission amplifiers the spectrally integrated intensity of the laser line increases as a function of plasma length,  $l$ , as

$$I = \left(\frac{E}{g}\right) (e^{gl} - 1)^{3/2} (gl e^{gl})^{-1/2}, \tag{1}$$

where  $g$  is the small signal gain coefficient, and  $E$  is a constant proportional to the emissivity.<sup>87</sup> Ideally, this nearly exponential amplification continues until the intensity approaches the saturation intensity. For example, in collisionally excited laser systems, gain saturation is typically reached when  $gl \approx 14-20$ .<sup>44–47,83</sup> In the example illustrated in Fig. 1, corresponding to the amplification of the 46.9 nm line of Ne-like Ar in a discharge-created plasma, the laser line intensity increases with a gain coefficient  $g \approx 0.92 \text{ cm}^{-1}$  until saturation is reached at  $l \approx 15 \text{ cm}$ .<sup>70,83</sup> In conclusion, to achieve saturated soft x-ray amplification in a single- or double-pass amplifier the gain coefficient must be, depending on the length of the plasma, 1–3 orders of magnitude larger than that typically encountered in most visible gas lasers.<sup>88</sup> Moreover, the fundamental physics of the generation of amplification by stimulated emission determines a dramatic upward scaling of the power density deposition required to obtain substantial gain at ultrashort wavelengths. The small signal gain coefficient is the product of the stimulated emission cross section  $\sigma$  and the population inversion density  $\Delta N$ .<sup>23,86</sup>

$$\Delta N = \left(N_2 - N_1 \frac{g_2}{g_1}\right), \tag{2}$$

$$g = \sigma \Delta N \cong \frac{A_{21} \lambda^2}{8 \pi \Delta \nu} \left(N_2 - N_1 \frac{g_2}{g_1}\right),$$

where the Einstein coefficient for spontaneous emission scales along an isoelectronic sequence as  $A_{21} \propto \lambda^{-2}$ . Considering as an example the case of a naturally broadened transition with  $\Delta \nu \propto A_{21}$  we obtain

$$g \propto \Delta N \lambda^2 \cong N_2 \lambda^2. \tag{3}$$

In turn, the minimum pump power density required to maintain a certain upper laser level population density  $N_2$  scales as

$$P = N_2 A_{21} \frac{hc}{\lambda} \propto N_2 \lambda^{-3}. \tag{4}$$

It results from Eqs. (3) and (4) that the power density required to obtain a certain gain coefficient in a naturally broadened transition scales as

$$P \propto g \lambda^{-5}. \tag{5}$$

In consideration of the case of Doppler broadening, the line-broadening mechanism most frequently dominant under soft x-ray laser operating conditions leads to a different but also dramatic scaling of the power requirement,  $P \propto g \sqrt{(kT_i / \mu)} \lambda^{-4}$ . Nevertheless, assuming for illustration purposes the natural broadening case, the operation of saturated, mirrorless lasers at 50 and 5 nm can be estimated to require a pump power density  $10^7$  and  $10^{12}$  times larger than a 500 nm blue–green laser, respectively, where it is assumed that the use of the cavity reduces the gain requirement for lasing in the visible by a factor of 100. In addition, the pump power required for lasing at soft x-ray wavelengths is often further increased by refraction losses that reduce the effective gain coefficient.

Another way to illustrate the large increase in excitation required for lasing at ultrashort wavelengths is to consider the plasma conditions necessary to sustain a significant population inversion. As an example, let us consider lasing by collisional electron impact excitation in the singly ionized (Ar II) and Ne-like (Ar IX) stages of argon at 488 and 46.9 nm, respectively. While for lasing in the blue in Ar II the necessary plasma density and temperature are typically  $N_e \approx 5 \times 10^{13} \text{ cm}^{-3}$  and  $T_e \approx 5 \text{ eV}$ ,<sup>29</sup> lasing at 46.9 nm in Ne-like Ar requires  $N_e \approx 5 \times 10^{18}$ ,  $T_e = 60-80 \text{ eV}$ .<sup>83</sup> This is more than a six-order magnitude increase in the  $N_e^* T_e$  product, which account for most of the large power density increase needed for lasing in the Ne-like ion. A further reduction of the laser wavelength to 8 nm, which can be achieved, for example, by collisional excitation of Ni-like Nd, requires an electron temperature of  $\approx 800 \text{ eV}$  and an electron density of about  $3 \times 10^{20} \text{ cm}^{-3}$ .<sup>89</sup> The very large pump power densities required to achieve these plasma conditions, and the often present requirement of a small optical thickness in the transverse direction,<sup>58</sup> define gain volumes that are small compared to those of longer wavelength plasma lasers. Typical dimensions of gain media for soft x-ray lasers range from 10 to 100  $\mu\text{m}$  in diameter and 0.1 to 5 cm in length. An exception are capillary discharge pumped lasers, which make use of plasma columns  $\approx 300 \mu\text{m}$  in diameter and up to 34 cm in length.<sup>17,18,70</sup>

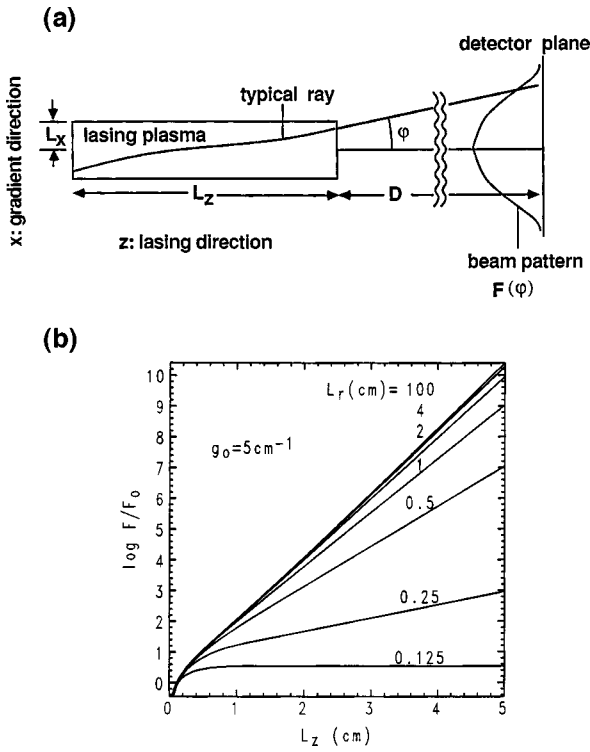

FIG. 2. (a) Schematic of ray propagating along a plasma column of dimensions  $2L_x, L_z$  having a density gradient in the  $x$  direction. Refraction deflects the ray. Constant properties are assumed in the  $y$  direction, which is perpendicular to the plane of the figure. (b) On-axis laser flux as a function of plasma length for several values of the refraction length  $L_r$ , as specified, assuming a gain coefficient  $g = 5 \text{ cm}^{-1}$ . For  $L_r < 0.2$  the exponential growth is not maintained (from R. A. London, Ref. 92).

**B. Refraction losses**

In the most commonly utilized soft x-ray laser excitation schemes the gain increases as a function of the plasma density. However, an upper limit is set by electron collisions that at sufficiently high electron density thermalize the populations of the laser levels, destroying the population inversion.<sup>58</sup> Another limit to the maximum usable plasma density is often imposed by refraction, that bends the x-ray beam out of the gain volume as a result of the variation of the index of refraction due to electron density gradients in the transverse direction. The index of refraction in a plasma is given by

$$\eta = \sqrt{1 - \frac{n_e}{n_{ec}}} \tag{6}$$

where  $n_{ec}$  is the critical density

$$n_{ec} = \frac{\pi m_e c^2}{e^2 \lambda^2} \tag{7}$$

Therefore, for a plasma column in which the electron density decreases as a function of distance away from an axis [Fig. 2(a)], the refractive index increases in that direction. In such a plasma, commonly encountered in many x-ray laser amplifiers, a ray propagating from a region of lower index of refraction to one of higher index of refraction is bent away from the axis and from the region of maximum gain. The problem caused by refraction on x-ray amplifiers was early

recognized by Chirkov,<sup>90</sup> and later analyzed by many others.<sup>91-96</sup> Refraction causes a loss that decreases the effective gain and, in the most severe cases limits the maximum amplification length. It also affects the direction and the spatial distribution of the amplified soft x-ray beam, increasing the beam divergence, deviating the beam, and causing (depending on the symmetry of the plasma) sidelobes in the beam profile<sup>44,92</sup> or annular beam patterns.<sup>17,97</sup> Measurements of the near-field and far-field intensity distributions that show the effects of refraction have been performed in several soft x-ray lasers.<sup>97-99</sup>

London<sup>92</sup> has analyzed the effect of refraction on the amplification for the case of a plasma with a density gradient in one dimension, as encountered when irradiating a foil target with a line-focused laser. Treating the density profile as parabolic, he showed that the typical distance in the direction of propagation  $z$ , in which a ray stays within the lasing medium before bending out, defined as the characteristic refraction length  $L_r$ , is

$$L_r = L_x \sqrt{\frac{n_{ec}}{n_{e0}}} \tag{8}$$

where  $n_{e0}$  is the maximum electron density. The corresponding refraction angle  $\phi_r$  can be expressed as

$$\phi_r = \sqrt{\frac{n_{e0}}{n_{ec}}} \tag{9}$$

In the one-dimensional case, refraction reduces the gain by  $1/L_r$  and determines for large plasma lengths  $L_z > L_r$  an effective gain coefficient

$$g_{\text{eff}} = g - \frac{1}{L_r} \tag{10}$$

London expressed the dependence of the on-axis radiation flux on plasma length as a function of a parameter, the refraction gain-length defined as

$$G_r = gL_r \tag{11}$$

From the above expression, Eq. (10), for the effective gain it follows that the length dependence of the laser intensity corresponds to one of two distinct cases determined by whether the refraction gain length is larger or smaller than 1. When  $G_r > 1$ , exponential growth of the laser power is maintained until the laser intensity reaches the saturation intensity. In contrast, when  $G_r < 1$ , refraction sets a limit to the exponential growth and the laser power reaches a constant value for large lengths, never achieving the saturation intensity [the case of the curve corresponding to  $L_r = 0.125$  in Fig. 2(b)]. Chilla and Rocca<sup>95</sup> extended the analysis to the case of cylindrical geometry, which is of interest for discharge-pumped lasers and axially pumped laser-created plasmas. In this case, in which the index has a gradient in two directions, refraction introduces a loss term  $1/L_r$  for each dimension and the effective gain is

$$g_{\text{eff}} = g - \frac{2}{L_r} \tag{12}$$



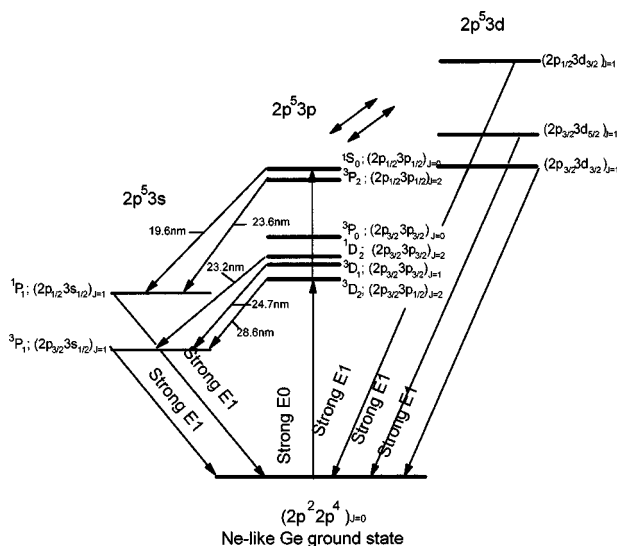

FIG. 3. Simplified Grotrian diagram of Ne-like Ge showing the laser transitions of interest and the dominant excitation and deexcitation processes responsible for the creation of population inversions between the  $3p$  and  $3s$  levels. The laser levels are labeled in both  $LS$  and  $jj$  notations. (See C. Keane, Ref. 54.)

Therefore, in this two-dimensional case, exponential growth of the intensity continues until saturation of the gain is achieved only if  $G_r > 2$ .

Several techniques have been successfully developed to reduce the detrimental effects of refraction. They include the use of curved laser targets, the reduction of sharp density gradients by the use of a prepulse in laser-pumped systems,<sup>100–117</sup> and the use of a magnetic field in discharge-pumped lasers.<sup>118</sup> Plasma waveguides having a density minimum on axis have also been developed<sup>74,119–123</sup> and successfully used in soft x-ray amplification experiments.<sup>74</sup> Plasma waveguides can be expected to have an important impact on the development of efficient table-top x-ray lasers.

### III. POPULATION INVERSION MECHANISMS

#### A. Collisional electron excitation

The collisional electron excitation scheme was one of the first explored theoretically in detail.<sup>22–27</sup> Several compact, high gain, laser-pumped<sup>75–79</sup> and discharge-pumped<sup>81–83,124</sup> soft x-ray amplifiers have been successfully developed based on this scheme. This x-ray laser excitation mechanism resembles that of some of the most widely utilized visible and ultraviolet ion lasers, the cw argon ion and krypton ion lasers,<sup>28,29</sup> in which the laser upper levels are predominantly excited by direct electron impact collision from the ground state of the ion stage of interest. In the most common implementation of these lasers, the generation of a population inversion occurs in a quasi-cw regime, aided by the very favorable radiative lifetime ratio between the laser upper and lower levels. The upper levels are metastable with respect to radiative decay to the ground state, and the laser lower levels are depopulated by strong dipole-allowed transitions. The first successful demonstration of lasing at soft x-ray wavelengths utilizing this approach was realized at Lawrence Livermore National Laboratory involved the

$3p-3s$  transitions in Ne-like Se and Ne-like Y.<sup>38</sup> Ne-like ions have a fully occupied outer shell and are hard to ionize. This is a significant advantage because it results in a high relative abundance of the lasing ions over a wide range of plasma parameters. To date, amplification has been demonstrated in the majority of the Ne-like ions having atomic number between Si (Ref. 125) and Ag.<sup>126</sup>

Figure 3 shows a simplified energy level diagram for a typical Ne-like system that illustrates the laser transitions and the dominant processes involved in the generation of amplification. It corresponds to the Ge XXIII laser first demonstrated at the Naval Research Laboratory by Lee *et al.*<sup>40</sup> The  $3p$  laser upper levels are populated by electron monopole collisional excitation  $E_0$  from the Ne-like ion ground state and also through recombination from the F-like ion, and by cascades from higher energy levels. A small contribution might also come from inner shell ionization of the Na-like state. The population inversions are maintained by the very rapid radiative decay of the  $3s$  laser lower levels to the ground state of the ion through strong dipole-allowed transitions  $E_1$ . Therefore, operation of these lasers in a quasi-cw regime requires the plasma to be optically thin for the transitions originating from the laser lower level. This imposes a restriction in the maximum plasma column diameter, that is often significantly relaxed by a Doppler shift in the lines caused by radial velocity gradients in the plasma.<sup>127–129</sup> The pumping rate and the population inversion increase with the electron density. However, as mentioned before, the maximum electron density at which an inversion can be maintained is limited by collisional mixing between the upper and lower laser levels.<sup>58</sup>

From the beginning of the study of soft x-ray lasing in Ne-like ions, models have predicted the largest gain to occur in the transition linking the  $(2p^5 3p^1 S_0)$  and  $(2p^5 3s^1 P_1)$  upper and lower levels, respectively ( $J=0-1$  line). This is because the highest monopole excitation rate into the  $3p$  manifold is to the  $J=0$  level. However, the first observation of amplification occurred instead in the  $J=2-1$  lines of Ne-like Se, in 1984.<sup>38</sup> Subsequent experiments conducted in the following few years confirmed the observation of larger gain in the  $J=2-1$  lines,<sup>44</sup> with the exception of experiments conducted in lower- $Z$  elements that showed slightly higher gain in the  $J=0-1$  line.<sup>40</sup> This apparent contradiction between theory and experiment in the distribution of the gain in high  $Z$  elements attracted significant attention, and gave origin to a number of suggested explanations.<sup>130–132</sup> Increased understanding of the cause of this anomaly resulted from recent experiments in laser-created plasmas that made use of a prepulse in the excitation. The prepulse significantly changes the spectral composition of the x-ray laser output, resulting in a great increase in the intensity of the  $J=0-1$  line.<sup>103–108</sup> An important characteristic of plasmas created following a prepulse is the reduced density gradients, and consequently reduced refraction. It was concluded that lasing in the  $J=0-1$  line takes place in regions of higher plasma density, where without a prepulse refraction losses significantly decrease the effective amplification of this line relative to the  $J=2-1$  line. The  $J=0-1$  line has been observed to be clearly dominant in low- $Z$  Ne-like ions generated by

either laser excitation of a solid target using a prepulse,<sup>103,104,108</sup> laser excitation of a gas-puff target,<sup>133</sup> or fast capillary discharges.<sup>81–83,124</sup>

The collisional electron excitation of Ne-like ions is one of the most studied and proven excitation mechanisms. It has originated some of the most robust soft x-ray lasers demonstrated to date, including several table-top soft x-ray lasers.<sup>17,76,78,83,124</sup> Nevertheless, it also has a significant disadvantage: the high degree of ionization and consequently the large pump power that is required to obtain lasing at a given wavelength. Alternatively, the Ni-like sequence has been proposed and successfully utilized to extend collisionally excited lasers to shorter wavelengths.<sup>43,44,77,115,116,134–144</sup> Lasers in the  $3d^94d-3d^94p$  transitions of Ni-like ions are direct analogs to lasers in  $2p^53p-2p^53s$  transitions in closed shell Ne-like ions, but have the advantage of producing amplification at a shorter wavelength for a given state of ionization. This higher quantum efficiency significantly reduces the pumping energy required to achieve lasing by collisional excitation at a selected wavelength. The  $4d$  levels are populated through a combination of direct electron monopole collisional excitation from the  $3d^{10}$  ground state of the ion and from cascading from upper levels. As in the case of Ne-like lasers, the laser lower level is rapidly depopulated by dipole-allowed radiative decay to the ground state. The highest gain is observed in the  $J=0-1$  line. Ni-like soft x-ray lasers were first demonstrated in 1987 in an Eu laser-created plasma, producing an amplification of  $gl \approx 4$  at 7.1 nm.<sup>43</sup> Subsequently, the scheme was isoelectronically extrapolated to other ions with laser wavelengths as short as 3.56 nm in Ni-like Au.<sup>126</sup> Hagelstein first proposed the use of low  $Z$  Ni-like ions to develop table-top collisional lasers at wavelengths near 20 nm and computed significant gain for overheated plasma conditions.<sup>138</sup> For several years the maximum amplification obtained in Ni-like ions remained smaller than that obtained in Ne-like systems, and below the values required for gain saturation. Nevertheless, the use of multiple-laser-pulse excitation techniques and the optimization of target geometries has greatly increased the gain in Ni-like ions.<sup>141–143,144</sup> Recently, gain saturated operation has been obtained at wavelengths as short as 7.3 nm.<sup>114,115,143</sup> The amplification of soft x-ray radiation by collisional excitation is not limited to Ne-like and Ni-like ions. Gain has also been observed in Co-like ions,<sup>140</sup> and the use of the Nd-like sequence has also been proposed.<sup>138,145</sup>

### 1. Transient electron collisional excitation

The collisional electron excitation scheme described above is intrinsically a quasisteady state scheme in which lasing can occur for as long as the plasma conditions necessary for the generation of a population inversion can be maintained. A recently demonstrated variation of the collisional electron excitation scheme takes advantage of the much larger population inversions that can be obtained under rapid transient excitation.<sup>76–78</sup> It was first recognized by Afanasiev and Shlyaptsev<sup>146</sup> that gain coefficients that are 1–2 orders of magnitude larger than those obtained for the same transition in the quasisteady state regime can be produced for a short period of time (typically subpicosecond to tens of

picoseconds) by heating the plasma at a rate faster than the relaxation rate of the excited states. The larger gain coefficients are a consequence of several phenomena that, for a short period following rapid transient heating, contribute to generate a much higher population inversion. These include the fact that immediately following rapid collisional excitation, and before collisions have the time to redistribute the populations, the upper laser level population is larger as a result of its larger rate of excitation. The other phenomena that contribute to an increased gain are the increased rate of electron excitation in an overheated plasma (recall that the excitation rate depends exponentially on the electron temperature), and a reduction in the rate of collisional mixing between the closely spaced active levels. The latter allows operation at significantly higher electron density, and therefore at increased pumping rates. Transient gains in excess of  $100 \text{ cm}^{-1}$  have been predicted theoretically.<sup>146–150</sup> The short-lived transient population inversions, which are pumped directly from the ground state by electron collisional excitation, last until collisions redistribute the populations among levels. Following this short transient period of high population inversion the gain decreases until the laser level populations finally reach the quasisteady state value. In summary, in the transient electron collisional excitation scheme a population inversion is created because the transient collisional processes of excitation of the laser upper and lower level occur at different rates, and not because of the faster rate of radiative relaxation of the laser lower level. Therefore, in the transient regime there is no need to limit the transverse dimension of the plasma in order to ensure optical transparency of the lower level radiation. The main advantage of the transient excitation scheme for the realization of table-top x-ray lasers is the greatly reduced laser pump energy required for excitation. For example, a few J/cm deposited in  $\sim 1$  ps in a line-focused plasma have produced gains of up to  $35 \text{ cm}^{-1}$  in the  $3p-3s$   $J=0-1$  line of Ne-like Ti at 32.6 nm.<sup>76,78</sup> The transient excitation scheme has been also extended to the Ni-like sequence, where a gain of  $35 \text{ cm}^{-1}$  was reported in the  $4d-4p$   $J=0-1$  line of Ni-like Pd at 14.7 nm utilizing  $\approx 5$  J of excitation energy.<sup>77,78</sup>

### B. Collisional recombination

This population inversion mechanism was first proposed by Gudzenko and Shelepin in 1965.<sup>20</sup> The first report of large amplification at soft x-ray wavelengths by plasma recombination ( $gl \approx 6$ ), corresponds to an experiment realized by Suckewer *et al.* in 1984.<sup>39</sup> More recently, recombining plasmas pumped by table-top lasers has produced amplification in transitions to the ground state<sup>72,74</sup> with gains up to  $gl \approx 6.5$  at wavelengths as short as 13.5 nm. Evidence of amplification by plasma recombination has also been reported in plasmas created by compact electrical discharges.<sup>66,151–155</sup> In this scheme, the laser upper level is populated following the recombination of ions with a charge  $Z+1$  with an electron, through a three-body interaction described as collisional or three-body recombination:



This type of process is the inverse of collisional electron ionization. It preferentially populates highly excited bound levels  $A^{Z*}$  of the ion of charge  $Z$ , favoring the generation of population inversion (the recombination rate scales with  $n$ , the principal quantum number of the level, as  $n^4$ ).<sup>156</sup> As the reaction above suggests, the collisional recombination rate  $R_{3br}$  is proportional to the square of the electron density. The recombination rate is also extremely sensitive to the electron temperature  $R_{3br} \propto T_e^{-4.5}$ .<sup>157</sup> Therefore, the generation of large population inversion by recombination requires a dense and relatively cold plasma.

Hydrogen-like ions, as originally suggested by Gudzenko and Shelepin,<sup>20</sup> have a very favorable energy level structure for the generation of population inversions by collisional recombination. In principle several transitions can be inverted, but initially much of the attention focused in the very favorable 3–2 transition of these ions. As an example, Fig. 4 shows the atomic processes involved in the generation of population inversion in the 3–2 transition of H-like C at 18.2 nm by collisional recombination. When the plasma cools, collisional recombination populates highly excited states, and electron collisions rapidly transfers the population to levels of lower energy. Since collisional electron de-excitation is inversely proportional to the square root of the energy difference between the levels,<sup>158</sup> this electronic cascade reaches a level at which electron de-excitation is no longer dominant over radiative decay. At this level the bottleneck that is produced in the cascade creates a population inversion respect to a lower level, that is most commonly de-excited by very rapid radiative decay to the ground state of the ion.

The amplification of soft x rays by plasma recombination would seem to require conflicting plasma conditions: a very highly ionized plasma and a very cold electron temperature. In practice, the problem has been traditionally solved utilizing a two-step process. First, a highly ionized and dense plasma is generated by a heating pulse. Second, the plasma is rapidly cooled following the termination of the excitation pulse. By this method the plasma is hot during the excitation pulse, allowing for the generation of the required high population density of ions  $A^{Z+1}$ , and cold during the recombination phase. The required cooling rate is determined by the recombination rate. The plasma can be rapidly cooled by an adiabatic expansion,<sup>30,31,37,127,159–166</sup> by electron heat conduction to a nearby wall or colder neighboring plasma,<sup>167</sup> or by radiation from high- $Z$  ions introduced as impurities into the plasma.<sup>168,169</sup> All three cooling mechanisms, or combinations of them, have been utilized experimentally to generate gain at soft x-ray wavelengths by collisional electron–ion recombination. In particular, important efforts have been devoted to the demonstration and study of amplification in the 18.2 nm 3–2 line of H-like C. Initial experiments observed population inversions in plasmas that were generated by ablating solid carbon targets or carbon fibers with high power laser pulses, and cooled by adiabatic expansion.<sup>30,31,35–37</sup> Large amplification was first observed in an experiment in which a 300 J pulse from a CO<sub>2</sub> laser with about 75 ns pulse width was used to generate a nearly totally ionized carbon plasma column by bombarding a carbon solid target im-

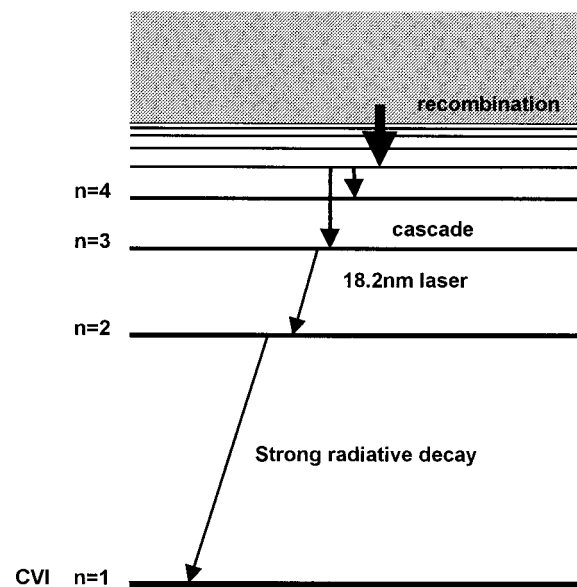

FIG. 4. Simplified Grotrian diagram of H-like C showing the processes responsible for the generation of population inversion between the  $n=3$  and  $n=2$  levels in the 18.2 nm C VI recombination laser.

mersed in a strong solenoidal magnetic field.<sup>39</sup> The magnetic confinement was allowed to maintain a high electron density while the plasma was cooled by radiation and electron heat conduction to adjacent cooling blades. Laser pulses of about 3 mJ were generated at an efficiency of  $10^{-5}$ . Amplification has also been demonstrated in numerous experiments in which line focus plasmas were cooled by free adiabatic expansion.<sup>41,160–165</sup> Gain has been reported in H-like Na ions,<sup>163</sup> in the  $4f-3d$  and  $5f-3d$  lines of Li-like ions,<sup>164–166</sup> and in Be-like and Na-like ions.<sup>170</sup>

An important advantage of the recombination scheme with respect to the collisional excitation scheme involving  $\Delta n=0$  transitions is its more rapid scaling to shorter wavelengths with nuclear charge  $Z$ . However, recombination lasers have suffered the problem of not scaling adequately with plasma column length. The largest gain length product achieved to date is  $gl \approx 8$ .<sup>39</sup> It is possible that the problem is related to the very high sensitivity of the gain in recombination schemes to the variation of the plasma parameters that can be more pronounced for longer plasma columns. Nevertheless, the causes of this limitation are not well understood<sup>171</sup> and are a topic of current discussion that must be resolved for x-ray recombination lasers to achieve their full potential.

### 1. Recombination lasing in transitions to the ground state

Jones and Ali<sup>172</sup> demonstrated theoretically that large transient gains could be generated in the 2–1 transitions of H-like ions following recombination of a totally ionized plasma of arbitrarily low temperature. This kind of laser scheme using a transition to the ground state is very attractive to rapidly scale recombination lasers to very short wavelengths. It provides a method to amplify with a high quantum efficiency very short wavelength lines in species which are only moderately ionized. For example, in this scheme lasing at 13.5 nm requires an initial plasma of totally stripped Li



ions (three times ionized atoms), while lasing at 3.37 nm can be attempted in C VI in a plasma that initially is only six times ionized. In the first case the quantum efficiency (QE), computed as the ratio of the laser photon energy and the energy required to totally strip the atom, is  $QE=0.45$ . This is a large improvement with respect to a recombination laser based on the 3–2 transition of H-like ions, that for lasing at a similar wavelength would require an inversion in H-like N ( $\lambda=13.4$  nm) with a  $QE=0.06$ . The high QE of laser transitions to the ground state offers a possible route for the development of very short wavelength lasers with small excitation energy, potentially resulting in very short wavelength table-top recombination lasers. However, for lasing to occur in a transition to the ground state, recombination has to be very rapid to allow for the generation of large upper laser level populations before the ground state ion level is significantly populated. The recombination time must then be shorter than the radiative lifetime of the laser upper level which is, for example, 26 and 1.6 ps for the  $n=2$  level of H-like Li and H-like C, respectively. These time scales are often shorter than the time required by any plasma cooling mechanism to cool a hot plasma before the ground state is significantly populated. Therefore, amplification in transitions to the ground state requires the generation of highly stripped ions in a plasma with a low electron temperature. Peyraud and Peyraud<sup>173</sup> proposed the use of multiphoton ionization to produce a plasma of fully stripped ions and cold electrons on a time scale that is short compared to the recombination time. However, means for the generation of initial plasma conditions for lasing in a transition to the ground state did not exist in 1975, the time of the analysis of Jones and Ali. The advent of very powerful subpicosecond lasers<sup>62–65</sup> and the understanding of above-threshold ionization<sup>174</sup> have made possible the relatively recent observation of soft x-ray amplification in transitions to the ground state.<sup>72,74,175</sup>

Burnett and Corkum<sup>176</sup> recognized that a cold plasma of highly stripped ions in which recombination can occur in the subpicosecond time scale can be created by optical-field-induced (OFI) ionization using linearly polarized light, and proposed the realization of ultrashort wavelength lasers utilizing this approach. For a linearly polarized laser pulse, the electrons are compelled to return their quiver energy to the laser field. This method can therefore create plasmas that are simultaneously highly ionized and cold in a time scale much shorter than their recombination time. Amendt and Eder and Eder *et al.*<sup>177,178</sup> analyzed different aspects of the implementation of soft x-ray recombination lasers based on OFI. The first observation of gain in an OFI plasma was reported by Nagata *et al.* in the 2–1 transition of H-like Li at 13.5 nm.<sup>72</sup> Experiments subsequently conducted at Princeton<sup>179</sup> and at Berkeley<sup>178</sup> observed similar results. Heating associated with Raman backscattering was recognized as a possible obstacle for extending this scheme to much shorter wavelengths. For schemes requiring pump laser intensities on the order of  $10^{17}$  W cm<sup>-2</sup>, e.g., Li-like Ne at 9.8 nm, it has been suggested that the use of short driving pulses (<100 fs) can provide a solution.<sup>178</sup> However, the same theoretical analysis concluded that it will be difficult to keep heating associated

to Raman scattering at acceptable levels in shorter wavelength schemes that require intensities on the order of  $1 \times 10^{18}$  W cm<sup>-2</sup>.<sup>170</sup> Experiments are needed to evaluate the implications of these potential limitations to the scaling of OFI recombination lasers. The progress in the development of OFI recombination lasers is summarized in a later section.

### C. Photoionization and resonant photopumping

These two population inversion mechanisms for x-ray amplification have in common that the excitation of the laser upper level population involves the use of high energy photons. The generation of large population inversions following the selective x-ray photoionization of inner shell electrons was originally proposed by Duguay and Rentzepis in 1967.<sup>21</sup> The generation of population inversions by this mechanism is possible because at photon energies just above the threshold for inner shell photoionization the cross section is an order of magnitude larger for inner-shell electrons as compared to outer-shell electrons. This scheme has the potential advantage of leading to relatively compact lasers with wavelengths shorter than 1.5 nm.<sup>180,181</sup> In principle, it can allow for operation at a low plasma temperature of less than 1 eV with consequently small Doppler broadenings and large gain coefficients. The incoherent x-ray photons that pump the laser media would be normally produced by a nearby plasma created by heating a target made of a high-Z material such as gold with an intense ultrashort laser pulse. Experiments have demonstrated total laser energy to incoherent x-ray energy conversion efficiencies of ~20% (>1% into x rays with energy above 1 keV). Photons at energy below the inner-shell binding energy are removed with an appropriate filter to avoid pumping of the laser lower level.

The first proposal for inner-shell photoionization lasers at x-ray wavelengths<sup>21</sup> has preceded by decades the development of sufficiently powerful ultrashort pulse laser drivers.<sup>62–65</sup> The photoionization scheme was first demonstrated in the visible region of the spectrum by Silfvast *et al.* in 1983.<sup>183</sup> McGuire proposed the production of population inversions by selective Auger decay following inner-shell photoionization.<sup>184</sup> In 1986 Kapteyn, Lee, and Falcone demonstrated lasing at 108.9 nm in doubly ionized Xe by Auger decay following the photoionization of neutral Xe.<sup>185</sup> Output energies of several  $\mu$ J in this transition were subsequently obtained at a 2 Hz repetition rate by Sher *et al.* utilizing traveling wave excitation.<sup>186</sup> Amplification in the equivalent transition in Kr at 90.7 nm was also observed.<sup>187</sup> However, no demonstration of a photoionization laser at x-ray wavelengths has yet been realized. Nevertheless, the recent development of relatively compact lasers capable of producing peak powers of up to 100 TW greatly increases the likelihood that this type of x-ray laser will be realized in the near future.

Kapteyn has analyzed the possibility of obtaining lasing by preferentially photoionizing the K-shell electrons of low-Z elements,<sup>180</sup> focusing in particular on the  $K_{\alpha}$  line of Ne ( $\lambda=1.5$  nm). Previously, Elton had discussed the possibility of obtaining quasistationary population inversion  $K_{\alpha}$  transitions,<sup>182</sup> and Hagelstein had analyzed the possibility of



producing a 27 eV laser by photoionizing the  $2s$  shell of neutral Ne to create a  $2p-2s$  inversion in Ne II.<sup>53</sup> A main advantage of the  $K_\alpha$  scheme is its scalability to very short wavelengths. The energy level diagram of the  $K_\alpha$  Ne laser is illustrated in Fig. 5. The filtered x rays primarily photoionize the inner-shell electrons, producing population inversion and gain in the allowed radiative transition between the  $(1s)^{-1}2S$  and  $(2p)^{-1}2P$  levels of the singly charged ion. Rapid Auger decay with a rate of  $(2.7 \text{ fs})^{-1}$  is the dominant mechanism of depopulation of the  $(1s)^{-1}$  laser upper level. However, the self-terminating lifetime is not the dominant process that limits the duration of the gain. Instead, the magnitude and duration of the gain is limited by electron collisional ionization of neutral neon atoms. The energetic electrons created in the lasing material by photoionization and Auger decay create predominantly ground-state Ne ions that are the laser lower level. Therefore, this is intrinsically an ultrashort pulse x-ray laser. Kapteyn has concluded that lasing in the  $K_\alpha$  transition of Ne at 1.5 nm could be produced by traveling-wave excitation using a pump laser generating  $\approx 10 \text{ J}$  pulses of approximately  $\approx 50 \text{ fs}$  duration.<sup>180</sup> In this scheme, the target would be a thin beryllium foil, which is coated on one side with a structured x-ray emitting material and supports a frozen mix of Ne-H on the other side. The beryllium acts as an absorber for low energy x rays that are capable of producing outer-shell ionization, and also separates the hot x-ray emitting region from the laser region so that thermal ionization of Ne does not take place. Hydrogen acts as an electron moderator in the lasing material to mitigate electron collisional ionization. The theoretical study of the  $K_\alpha$  photoionization lasers was extended by Eder and co-workers<sup>178,181,188</sup> who calculated a scaling law relating the necessary laser pump energy  $E_L$  to the wavelength that can be achieved. Assuming 20 fs x-ray pump pulses, they obtained  $E_L = (4.5/\lambda)^2$ , where the laser wavelength  $\lambda$  is in nm and  $E_L$  is in J.<sup>189</sup> Calculations for inner-shell photoionized lasing in C at 4.5 nm suggest that a driving laser energy on the order of 1 J should be sufficient to produce a gain coefficient of  $10 \text{ cm}^{-1}$  and a large gain-length product.<sup>188</sup> Barty *et al.* have proposed another approach to the pumping of inner-shell x-ray lasers, in which the pumping is not based on x-ray photons but rather on a burst of fast electrons produced by an ultrashort pulse laser.<sup>63</sup> A major motivation for this scheme is the nearly 100% efficiency with which a circularly polarized high-intensity optical laser can produce a burst of electrons with a pulse width and energy roughly corresponding to the duration and ponderomotive energy of the irradiating laser, respectively. Nevertheless, atomic electron impact ionization cross sections favor outer-shell ionization over inner-shell ionization, and thus the automatic population inversion that is possible with x-ray pumping no longer takes place in this scheme. However, the scheme proposed by Barty *et al.* relies instead on the Coster-Kronig mediated decay of the laser lower level to create the inversion.<sup>63</sup>

A different pumping mechanism also based on the excitation by energetic photons involves resonant photoabsorption.<sup>190,191</sup> In contrast with the photoionization scheme discussed above, which can make use of a broadband x-ray

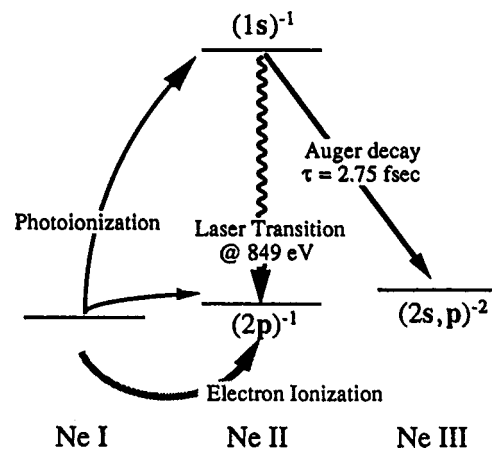

FIG. 5. Simplified energy level diagram of a proposed inner-shell photoionization laser in the  $K_\alpha$  transition of Ne at 1.5 nm. X rays photoionize the  $1s$  electrons of the Ne atoms creating a population inversion and gain in the  $(1s)^{-1} \rightarrow (2p)^{-1}$  transition of singly ionized Ne. Rapid Auger decay depletes the  $(1s)^{-1}$  laser upper level. Electron impact ionization populates the  $(2p)^{-1}$  laser lower level limiting the duration of the gain (from H. C. Kapteyn, Ref. 180).

pump source, resonant photopumping relies on very intense line emission to pump the laser upper level. Therefore, this mechanism requires a precise wavelength coincidence between powerful pump lines and lines that can populate a laser upper level by resonant photoabsorption from a highly populated state, typically a ground state. It was recently shown by Nilsen *et al.* that the amplification observed in the  $3d^1P_1-3p^1P_1$  line of Ne-like Ar at 45.1 nm in a laser-created plasma was assisted by photopumping due to reabsorption of the  $3d^1P_1-2p^1S_0$  resonance line.<sup>192</sup> This mechanism of self-pumping of a strong emission line in an optically thick plasma has also been proposed as a mechanism for driving the population into the laser upper levels of other Ne-like and Ni-like ions.<sup>193</sup> However, a directly photopumped x-ray laser has not yet been realized. This excitation mechanism has nevertheless produced amplification at ultraviolet wavelengths,<sup>194-196</sup> and a large number of laser proposals based on x-ray line-coincidence studies are awaiting realization.<sup>53,58,197-202</sup> Significant efforts have been dedicated to attempt the demonstration of amplification at 23.1 nm in He-like Ne by resonant photoexcitation of the  $1s^2-1s4p^1P_1$  transition in that ion with 1.1 nm radiation from He-like Na plasmas generated by very large pulsed-power generators.<sup>203-205</sup> An experiment conducted in 1992 at Sandia National Laboratory using the Saturn generator, at the time the world's most powerful pulsed-power machine, produced 200 GW in the 1.1 nm Na pump line and obtained evidence of a population inversion in He-like Ne.<sup>205</sup> However, no gain was reported. Of greater interest for the development of table-top lasers are experiments that have been conducted with more compact drivers.<sup>206-208</sup> Gain on the order of  $1 \text{ cm}^{-1}$  and a  $gl \approx 2$  was reported in the  $3d-4f$  and  $3d-5f$  lines of Li-like Mg ions, pumped by a Si plasma created by a laser pulse of 120 J energy and 400 ps duration.<sup>206</sup> Another experiment observed an enhancement of the population of the upper level of a Mo VII transition near 60 nm when photopumped by a line in Mo XII from an adja-

cent laser-created plasma.<sup>207</sup> Also, a resonant photopumping study of Be-like Mg IX ions by Li-like Al XI line radiation has been performed driving an Al pinch with a 0.5 TW pulsed power generator.<sup>208</sup> The objective of this experiment was to obtain amplification on the Mg IX  $2s4p-2s3d$  transition at 2.28 nm. Evidence of fluorescence from the  $4p$  level of Mg IX due to photopumping by the 4.83 nm line of Al XI was reported.

The population inversion mechanisms discussed above are by far the most studied, and include all the soft x-ray lasers demonstrated to date. However, other x-ray population inversion schemes based on different atomic processes such as charge transfer, have also been proposed.<sup>58,209-211</sup> Recently, Hagelstein analyzed the possibility of extending the concept of lasing without inversion to soft x-ray wavelengths.<sup>212</sup>

#### IV. PRESENT STATUS OF TABLE-TOP DRIVERS

Many of the recent advances in table-top soft x-ray lasers have been made possible by the development of new compact high power drives. Up to the late 1980s practically all soft x-ray amplification experiments made use of high-energy optical laser drivers that generated pulses of nanosecond duration. Large pulsed-power generators were also used in attempts to obtain soft x-ray amplification, but did not succeed in observing gain. While research towards the development of table-top x-ray lasers based on nanosecond pulse laser drivers continues to date,<sup>80</sup> much of the recent effort has shifted towards the use of small-scale high power ultrafast laser drivers<sup>74-78,216</sup> and compact high power discharges.<sup>17,68-70,81-83,124,152-155</sup> New opportunities for the efficient pumping of table-top soft x-ray lasers have arisen from the development of compact, very high power ultrafast optical lasers based on the technique of chirped-pulse amplification (CPA), and from the demonstration of highly ionized capillary discharge plasma columns of unprecedented axial uniformity. CPA of ultrashort laser pulses presently allows for the generation of multiterawatt peak powers from table-top systems operating at repetition rates of typically 10 Hz.<sup>62-65</sup> Compact fast capillary discharges have been shown to successfully concentrate large amounts of electrically stored energy in needle-shaped plasma columns with length to diameter ratios approaching 1000:1 and excellent axial uniformity.<sup>68-70,81-83</sup> The characteristics of these drivers for table-top lasers are summarized in the following sections.

##### A. High power ultrashort-pulse lasers

The high power ultrashort pulse drivers used in table-top x-ray laser research are based on either excimer-based or solid-state amplifier media. Ultrashort pulse excimer based systems have been available since the 1980s and typically produce pulses of 0.3-0.5 ps duration and energy up to a few hundred mJ.<sup>213-215</sup> However, the output energy of relatively compact high power excimer amplifiers is limited to these values by the low saturation fluence ( $\approx$ mJ/cm<sup>2</sup>). Presently, the majority of compact high-peak power laser systems use CPA in solid-state amplifiers, a scheme first demonstrated by Mourou and co-workers<sup>217</sup> based on the concepts of optical

pulse compression developed by Treacy<sup>218</sup> and Martinez.<sup>219</sup> This approach allows us to take full advantage of the high saturation fluences ( $\sim$ 1 J cm<sup>2</sup>), broad gain bandwidth, and relatively long upper laser level lifetime of solid-state amplifier media such as Ti:sapphire, Nd-glass, and Cr:LiSAF. The result has been the development of terawatt peak-power optical lasers operating at pulse repetition rates of 10 Hz that can fit on a single optical table, and larger systems producing several tens of terawatts that fit in a few optical tables.<sup>62-65</sup> The characteristics and design issues of high power ultrafast laser systems have been recently reviewed in detail by Backus *et al.* in a previous issue of this journal.<sup>62</sup> Nevertheless, for completeness the basic concept and status of CPA high power ultrashort-pulse laser drivers for table-top soft x-ray laser research are briefly summarized below.

In the CPA technique, a short seed pulse is first stretched in duration, then amplified, and finally recompressed to ideally its initial duration.<sup>217</sup> The process allows us to obtain extremely high peak powers by the amplification of ultrashort pulses, while avoiding very high intensities in the amplification pulse that would damage the amplifiers.<sup>62,64,217</sup> A schematic description of a CPA amplifier system is illustrated in Fig. 6. Low-energy seed pulses ( $1-10 \times 10^{-9}$  J) are typically produced by a mode-locked oscillator, most commonly a Ti:sapphire laser pumped by a cw Ar ion laser or a diode-pumped frequency-doubled Nd:YAG laser. The discovery of Kerr lens mode locking<sup>220,221</sup> and its subsequent refinements,<sup>222</sup> have produced pulses as short as  $\approx$ 4 fs and have made the generation of sub-20 fs seed pulses a routine. Prior to amplification, the seed pulse is stretched in duration by a factor  $10^3-10^4$  by introducing a frequency chirp, with a corresponding reduction in intensity. The concepts of dispersion control developed by Martinez<sup>219</sup> allow for the construction of a perfectly matched stretcher-compressor pair. The stretcher, that in its original design consisted of a pair of diffraction gratings in an antiparallel configuration containing a telescope composed by two identical lenses, generates large positive dispersion factors. For the amplification of very short seed pulses it is necessary to implement a stretcher that matches the dispersion of the compressor and of all other dispersive elements in the system, including the gain medium, Pockel cells, polarizers, isolators, etc. This has been accomplished with all-reflective stretchers, which present several advantages.<sup>62,223</sup> The stretched seed pulses are first amplified to 1-10 mJ by either a regenerative or a multipass amplifier, and are subsequently injected into one or more amplifiers. The design of ultrashort-pulse laser amplifiers must take into account the gain narrowing that results from the reduction of the bandwidth of the amplified pulse caused by the larger amplifications of the frequency components, which are closer to the central frequency of the gain medium.<sup>62</sup> However, gain narrowing has not precluded the amplification of sub-20 fs pulses to peak powers up to 100 TW.<sup>62,65,224</sup> Following amplification, the pulse is finally recompressed close to its original pulse width by a pair of identical parallel gratings that provide a negative group delay dispersion. In very high power systems, at least the final grating compressor is enclosed in a vacuum chamber to avoid wave front distortion and filamentation.

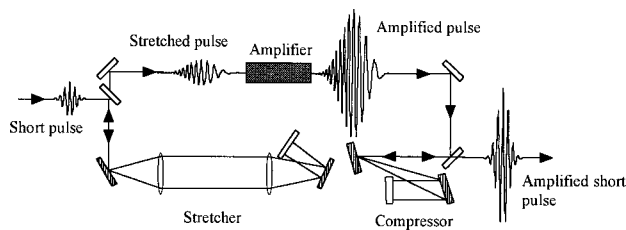

FIG. 6. Schematic diagram of a high-power ultrashort-pulse laser system based on chirped pulse amplification. The shaded rectangles in the expander and compressor setups represent diffraction gratings (from Backus *et al.*, Ref. 62).

Relatively compact ultrashort pulse optical laser systems with peak powers in the 5–100 TW range have been recently demonstrated based on the CPA technique.<sup>62–65</sup> A schematic of a multi-TW laser system developed at the Max Born Institute is illustrated in Fig. 7. It consists of a hybrid CPA system utilizing a Ti:sapphire oscillator and regenerative amplifier and a Nd:glass amplifier chain designed to produce a synchronized sequence of a long pulse (1.2 ns of up to 7 J) and a short pulse (0.7 ps of up to 4 J).<sup>76,225</sup> In this system, a seed pulse produced by a Ti:sapphire oscillator is chirped to  $\approx 1$  ns in a double pass grating stretcher. A single pulse is switched out of the oscillator and is amplified in a regenerative amplifier. The output pulse is further amplified in a chain of five Nd:phosphate glass amplifiers before being split to form two beams that are amplified in two final amplifier arms. The pulse from one arm is compressed in a grating compressor that is enclosed in an evacuated box to produce a short pulse of 0.7 ps duration. The two pulses have orthogo-

nal polarization in order to recombine them with a polarizer prior to focusing them onto the solid target. This implementation allows a jitter-free synchronization of the two pulses. As discussed later, this type of laser system has been successfully used to generate very large transient population inversions in Ne-like and Ni-like ions.<sup>76–78,225,226</sup> Great progress has also been recently achieved in the development of sub-20 fs systems that are likely to lead to the demonstration of gain in inner-shell transitions in the near future. A 50 TW, sub-20 fs Ti:sapphire system capable of operating at 10 Hz has been demonstrated at the University of California at San Diego<sup>63</sup> and a 100 TW, 19 fs, 10 Hz system has been recently completed at JAERI (Japan).<sup>224</sup> Systems with similar characteristics and peak powers up to 30 TW have also been built at several other institutions.<sup>64</sup> For more details on high power ultrafast lasers, the reader can refer to the review paper by Backus and references therein.<sup>62</sup> While some of the above lasers represent the state of the art in terms of output powers for relatively compact systems, smaller ultrashort-pulse lasers with lower output powers have also made significant contributions towards the development of table-top soft x-ray lasers,<sup>72–75</sup> and are likely to continue playing a role in the future.

**B. Fast capillary discharges**

Direct excitation of plasma columns with an electrical discharge has the potential advantage of generating soft x-ray lasers that are very efficient and compact. However, axial inhomogeneities in the plasmas of high power dis-

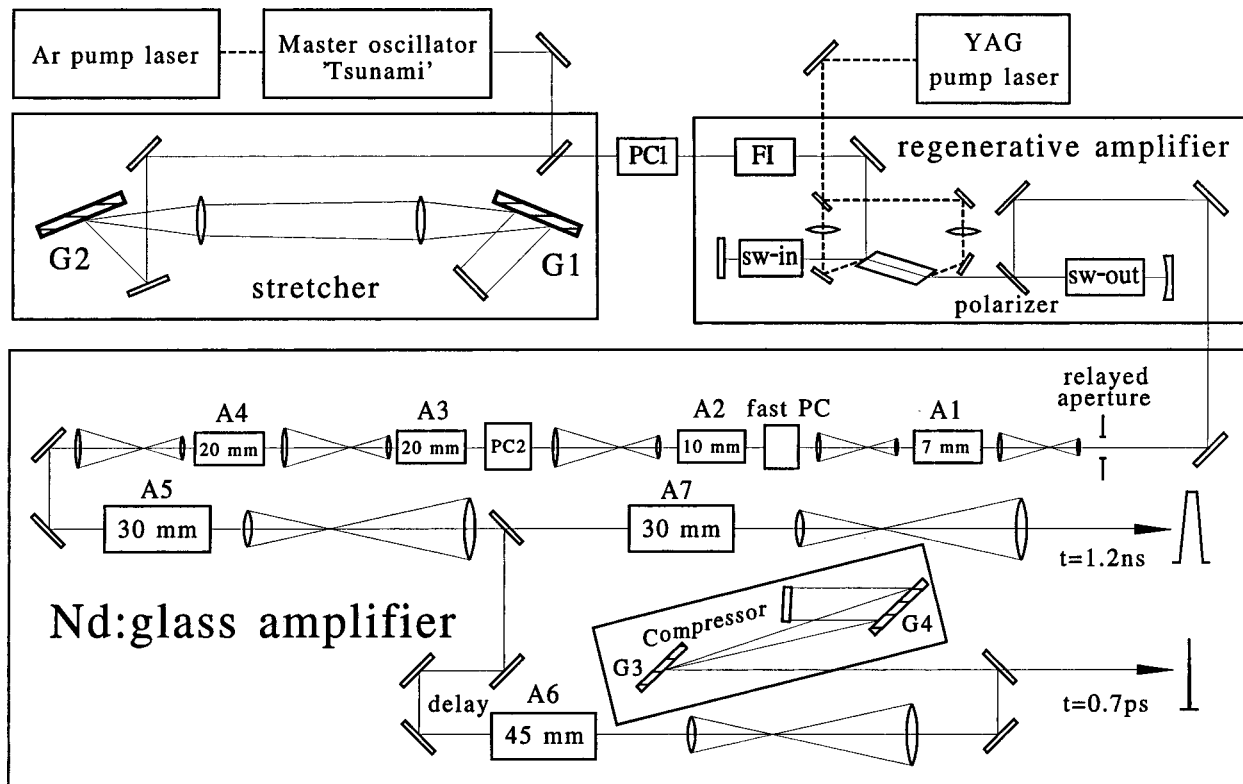

FIG. 7. Schematic diagram of the high power CPM hybrid laser system developed at the Max Born Institute to pump transient inversion soft x-ray lasers by a sequence of a long and a short pulse. This laser was successfully used to pump transient-inversion collisional lasers in Ne-like Ti and Ne-like V (Ref. 76). (Diagram courtesy of P. V. Nickles, MBI).



charges, produced by nonsymmetric compressions and instabilities, have impeded for many years the development of discharge driven soft x-ray lasers. Recently, this situation has dramatically changed with the demonstration of saturated table-top lasers driven by capillary discharges.<sup>83</sup> Fast discharge excitation of capillary channels 1.5–4 mm in diameter filled with preionized material has resulted in the successful compression of a significant fraction of the discharge power into plasma columns of  $\sim 300\ \mu\text{m}$  diameter, achieving the high power density deposition and the good axial uniformity necessary for soft x-ray lasing.<sup>68,69,82</sup> Fast compression of larger diameter plasmas in Z-pinch discharges has also generated axially uniform columns<sup>227</sup> in which soft x-ray amplification by collisional recombination has been investigated.<sup>153</sup>

Rocca *et al.* first proposed the development of soft x-ray lasers based on fast capillary discharges in 1988.<sup>228</sup> Prior to their use in soft x-ray laser research, discharges in evacuated plastic capillaries had been investigated for applications in spectroscopy, microscopy, and lithography.<sup>229–232</sup> However, with the exception of an experiment in an evacuated teflon capillary excited with a  $\approx 10\ \text{ns}$  rise time pulse,<sup>232</sup> most of these plasmas had been excited with relatively slow current pulses with rise times  $\geq 50\ \text{ns}$ . In these slow discharges, the large mass of wall-ablated material typically limited the electron temperature to values  $< 60\ \text{eV}$ . These plasmas were typically generated by discharging a low inductance capacitor (5–100 nF) through a circuit in which the capillary channel also acts as the main discharge switch with the purpose of minimizing the inductance. Capillary discharges of this kind have been employed to investigate gain by collisional recombination.<sup>66,151,152,233–236</sup> The capillary discharges that to date have proven to be most successful for soft x-ray laser excitation have a rapid current rise time, typically 10–40 ns. The fast current rise time minimizes the amount of material that is ablated from the capillary walls before the magnetic field compresses the plasma, detaching it from the walls.<sup>68,82,83</sup> Diagnostics<sup>68,82,237,238</sup> and modeling<sup>82,83,129,240,241</sup> confirmed that the plasma of these fast capillary discharges is not a stationary homogeneous column, but that it rapidly contracts, heats up, and expands, constituting a kind of wall-influenced Z pinch. These fast compressional capillary discharges have several demonstrated advantages to pump compact and efficient soft x-ray lasers: first, the very high efficiency with which they can create plasmas with high densities of multiply ionized species;<sup>68,69,239</sup> second, the possibility to generate plasma columns with very large aspect ratios (up to  $\approx 1000:1$ );<sup>70,83</sup> third, the very high axial uniformity that results from highly uniform initial conditions, a very rapid compression, and possible wall-stabilizing effects,<sup>129</sup> and fourth, the rapid motion of the plasma at the time of lasing, that causes a strong dynamic Doppler shift that helps to radiatively depopulate the laser lower level as a result of a reduction of the radial opacity.<sup>129</sup>

Figure 8 is an schematic representation of the pulsed-power generator and capillary discharge setup that was successfully used to amplify the 46.9 nm line of Ne-like Ar to intensities exceeding the saturation intensity.<sup>68,82,83</sup> The capillary was placed in the axis of a 3 nF liquid dielectric ca-

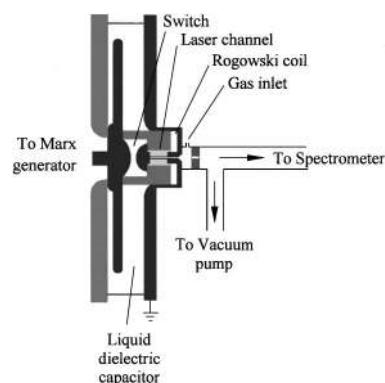

FIG. 8. Schematic diagram of the capillary discharge setup used to obtain saturated amplification of the 46.9 nm line of Ne-like Ar (from Rocca *et al.*, Refs. 68 and 82).

pacitor that was pulse charged by a Marx generator. The capillary loads were excited by discharging the capacitor through a spark-gap switch pressurized with SF<sub>6</sub>. The generator was used to excite Ar plasma columns up to 20 cm in length with current pulses of  $\approx 39\ \text{kA}$  peak amplitude and 75 ns first half cycle duration.<sup>70</sup> The same generator was also used to excite capillary channels of 1 mm diameter and 1 cm length with current pulses of  $> 100\ \text{kA}$  peak amplitude and 11 ns 10%–90% current rise time.<sup>66</sup> A more compact discharge setup based on a Blumlein transmission line that occupies a space of only  $0.4 \times 1\ \text{m}^2$  in an optical table was used to produce laser output pulses with energy up to 25  $\mu\text{J}$  in the 46.9 nm line of Ne-like Ar.<sup>245</sup> A photograph of this discharge is shown in Fig. 14 in Sec. V. More recently, a capillary discharge laser of similar size produced an average output pulse energy of 0.88 mJ at a repetition rate of 4 Hz at this wavelength.<sup>18</sup> A higher power capillary discharge that generates current pulses of up to 200 kA with a 10%–90% rise time of  $\approx 10\ \text{ns}$  was recently developed to explore the generation of the plasma conditions that are necessary for amplification at shorter wavelengths.<sup>242</sup> The final stage of the pulse generator consists of a radial water-dielectric Blumlein transmission line. The very rapid current rise time is obtained by switching the transmission line through an array of seven synchronized spark-gap switches.

The high efficiency with which these fast capillary discharges can generate highly ionized plasma columns is illustrated by the remarkable similarity of the two Ar spectra shown in Fig. 9.<sup>239</sup> The spectrum in Fig. 9(a) corresponds to a 43 kA, 13 ns rise time, 28 ns full width at half maximum (FWHM) discharge through a 2.5-mm-diam Ar-filled capillary channel,<sup>239</sup> while the spectrum in Fig. 9(b) is from a 1 MA current implosion in a large multiterawatt pulsed power machine (Gamble II, see Ref. 243). Argon plasmas driven by a 51 kA current pulse of similar characteristics in 1.5 mm diam capillaries were reported to reach an electron temperature of  $> 150\ \text{eV}$ .<sup>68</sup> Moreover, spectra of similar discharges in CaH<sub>2</sub> and TiH<sub>2</sub> capillaries showed that the electron temperature is sufficient to excite the upper laser levels in Ne-like Ca and Ti.<sup>69,239</sup>

The dynamics of the plasma column of a fast capillary discharge is illustrated in Fig. 10 by a sequence of time-resolved end-on soft x-ray pinhole camera images.<sup>237</sup> The

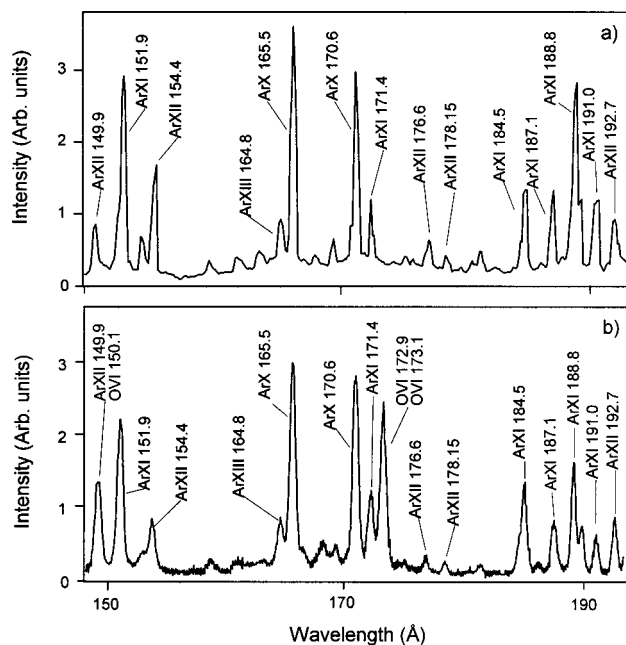

FIG. 9. Argon spectra corresponding to: (a) 1 MA current implosion in the Gamble II generator (Ref. 243) and (b) 43 kA, 30 ns FWHM discharge current pulse through a 2.5 mm diam capillary (Ref. 239). Transition wavelengths are in Å.

images correspond to a plasma generated in a 4 mm diam polyacetal capillary filled with 700 mTorr of Ar by a current pulse of 62 ns first half-cycle duration and 39 kA peak amplitude. During the first part of the current rise time, the distribution of the current density and the soft x-ray incoherent plasma emission are localized near the capillary wall [Fig. 10(a)]. Subsequently, the electromagnetic forces of the rising current pulse create a shock wave and rapidly compress the plasma to a size of about 300  $\mu\text{m}$  diameter [Figs. 10(a)–10(d)]. A significant part of the current (20%–50%) is computed to flow through material ablated from the capillary walls by plasma radiation and heat conduction.<sup>83</sup> The optimum conditions for lasing by collisional electron excitation occur several ns before stagnation, when the first compression shock wave reaches the axis. Finally, the plasma column expands and cools [Figs. 10(e)–10(g)]. A second less significant compression, that is of no interest for lasing, occurs later in time [Fig. 10(h)]. Figure 11 illustrates the calculated evolution of the electron temperature and density in the vicinity of the axis of a similar Ar capillary discharge plasma excited by a current pulse having a half-cycle duration of about 70 ns. Lasing by collisional electron excitation of Ne-like Ar ions takes place at a time when the electron density is rapidly increasing and reaches  $(0.3\text{--}1 \times 10^{19} \text{ cm}^{-3})$ , when the electron temperature is 60–80 eV.<sup>83,241</sup> Subsequently, the electron density continues to increase as the plasma stagnates, and laser action ceases due to increased refraction and collisional thermalization. The electron density and the spontaneous emission reach their peak values at stagnation 5–8 ns after the laser pulse.

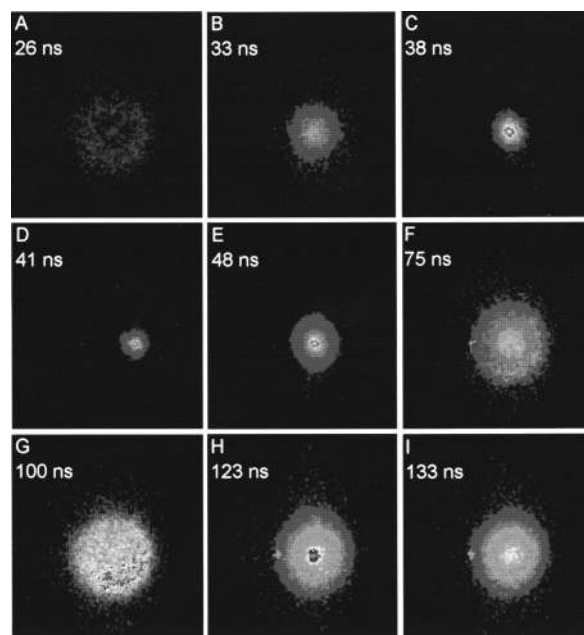

FIG. 10. Sequence of time-resolved pinhole images of an Ar capillary discharge plasma viewed end-on. The capillary diameter is 4 mm and its length 12 cm, and the Ar pressure is 700 mTorr. The current pulse has an amplitude of  $\approx 39$  kA and a half period duration of 62 ns. The timing with respect to the origin of the current pulse is indicated. The images corresponding to times near maximum compression [(9D), (E)] were acquired with reduced detector sensitivity to avoid saturation (from Tomasel *et al.*, Ref. 237).

## V. SPECIFIC LASER SYSTEMS

### A. Capillary discharge lasers

#### 1. Ne-like Ar laser

The first observation of large soft x-ray amplification in a discharge-created plasma was realized in 1994 by Rocca *et al.* in the  $3p\text{--}3s$   $J=0\text{--}1$  line of Ne-like Ar at 46.9 nm using the fast capillary discharge setup illustrated in Fig. 8.<sup>81,82</sup> In that initial experiment, a discharge current pulse of 60 ns half-cycle duration and  $\approx 40$  kA peak current was used to excite Ar plasma columns in 4 mm diam capillary channels up to 12 cm in length. Figure 12 shows the measured increase of the intensity of the 46.9 nm line as a function of plasma column length, that corresponds to a gain-length product of  $gl=7.2$  for the 12 cm long plasma columns. A small gain was also observed in the  $J=2\text{--}1$  line of Ne-like Ar at 69.8 nm.<sup>82</sup> The existence of small amplification in the  $J=2\text{--}1$  line was later also reported by Hildebrand *et al.*<sup>244</sup> Subsequent experiments employed longer plasma columns, up to 20 cm in length, under better optimized discharge conditions. Double-pass amplification experiments were also conducted using an Ir mirror.<sup>83</sup> The latter experiments yielded an effective gain-length product of  $gl=27$ . These experiments resulted in the first observation of gain saturation in a table-top soft x-ray amplifier. The results of single-pass amplification measurements for capillary plasma columns up to 15.8 cm in length are shown as open circles in Fig. 13. The energy of the laser pulse is observed to increase exponentially for lengths up to about 12 cm, where it begins to saturate. A fit of the data corresponding to plasma columns up to 11.5 cm with the Linford formula<sup>87</sup> yields a gain

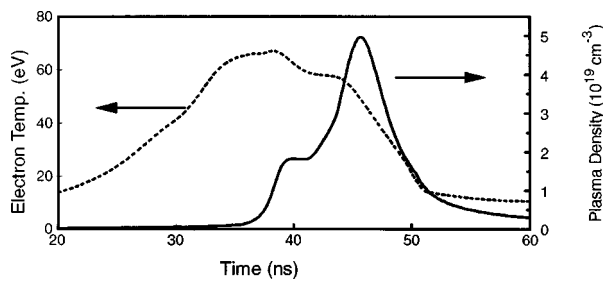

FIG. 11. Computed variation of the electron density and temperature on the axis of an Ar capillary discharge amplifier. The capillary diameter is 4 mm, the Ar pressure 700 mTorr, and the current pulse has a half-cycle duration of 70 ns and a peak amplitude of 39 kA (from Shlyaptsev *et al.*, Ref. 241).

coefficient of  $1.16 \text{ cm}^{-1}$ . Saturation of the laser intensity was observed at gain-length products of about 14. The measured saturation behavior was found to be in good agreement with the result of two independent radiation transport models for the capillary plasma columns. The solid line in Fig. 13 is the result of calculations performed assuming parabolic gain and density profiles, while the dashed line correspond to computations conducted for the time-dependent electron density and gain profiles obtained from magnetohydrodynamic and atomic physics calculations.<sup>83</sup> It should be noted that in these calculations consideration of refraction losses was found to be essential to adequately describe the measured energy dependence on plasma column length. The laser pulse width was measured to be about 0.8 ns.<sup>83</sup>

Based on the results summarized above, very compact saturated 46.9 nm lasers of size comparable to that of many widely utilized visible and ultraviolet gas lasers were developed.<sup>17,18,245</sup> Figure 14 illustrates the size of one of these capillary discharge soft x-ray lasers in comparison to a 5 mW He-Ne laser. The soft x-ray laser occupies a surface space of about 1 m by 0.4 m in an optical table.<sup>245</sup> This capillary discharge pumped table-top laser was successfully used to perform high resolution soft x-ray laser interferometry and shadowgraphy of plasmas.<sup>246,274</sup> Recently, a capillary discharge soft x-ray laser of similar size was operated at a repetition rate of 7 Hz to produce an average output pulse energy of 135  $\mu\text{J}$ , corresponding to an average laser power of  $\approx 1 \text{ mW}$ .<sup>17</sup> The latest results include the generation of laser pulses with an average energy of 0.88 mJ at a repetition rate of 4 Hz in a highly saturated amplifier.<sup>18</sup> Figure 15 illustrates the laser output energy and average output power characteristics of this laser that used a ceramic capillary 34.5 cm in length. The spatially coherent average output power per unit bandwidth emitted by this compact table-top laser at 26.5 eV is comparable to that generated by a beam line at a third generation synchrotron facility.<sup>17</sup> Its peak coherent power per unit bandwidth exceeds that of the synchrotron by nearly 6 orders of magnitude. With a peak spectral brightness of  $\approx 1 \times 10^{23}$  photons/(see  $\text{mm}^2 \text{ mrad}^2 0.01\% \text{ BW}$ ) this table-top laser is among the brightest soft x-ray sources available.

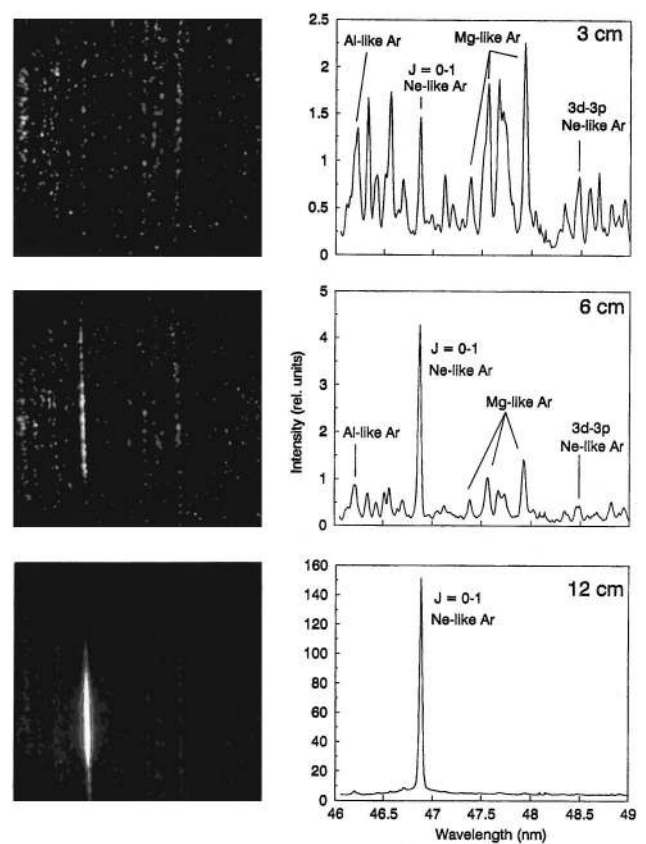

FIG. 12. Axial spectra of Ar capillary discharge for three different plasma column lengths showing lasing in the 46.9 nm line of Ne-like Ar. A strong increase of the laser line intensity is observed (from Rocca *et al.*, Ref. 81).

## 2. Ne-like Ar capillary discharge laser beam characteristics: Near-field and far-field patterns, and spatial coherence

The beam divergence and intensity distribution patterns from the Ne-like Ar capillary discharge laser were systematically measured over a wide range of discharge parameters.<sup>97</sup> Figure 16 shows the variation of the two-

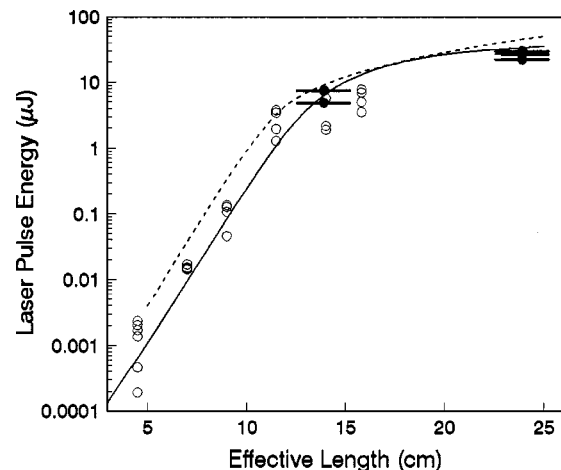

FIG. 13. Measured and computed 46.9 nm laser output energy as a function of capillary discharge plasma column length. Single and double-pass measurements are indicated by open and full circles, respectively. The lines are the result of two different radiation transport calculations (from Rocca *et al.*, Ref. 83).



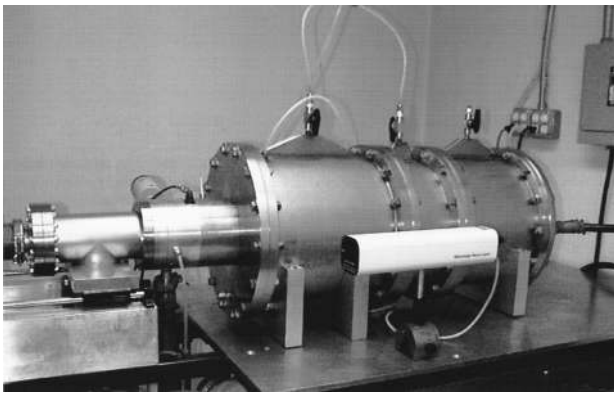

FIG. 14. Photograph comparing the size of a saturated table-top 46.9 nm capillary discharge laser (back) to a 5 mW He-Ne laser (front) (from Colorado State University).

dimensional near-field and far-field intensity distribution of the laser output as a function of discharge pressure for discharges in a 4 mm diam polyacetal capillary. The size of the beam at the exit of the amplifier and its divergence were observed to increase from about 150 to 300  $\mu\text{m}$  and from 2 to 5 mrad, respectively, as the pressure was decreased from 750 to 500 mTorr. Simultaneously, the beam intensity distribution changed from a single-peaked pattern to an annular profile. These effects were shown to be the result of increased refraction in the lower pressure discharges caused by larger electron density gradients.<sup>97</sup> The larger gradients are mostly the result of a stronger compression and a reduced plasma column size in the lower pressure discharges. The spatial images of the beam intensity distribution corresponding to the higher pressure discharges are seen to have a very good cylindrical symmetry, and significantly less structure than those that have been reported for laboratory-size laser-driven soft x-ray lasers.<sup>102</sup>

Another important laser beam characteristic is its degree of spatial coherence. Measurements in a capillary discharge pumped Ne-like Ar 46.9 nm laser observed for the first time a monotonic increase of the spatial coherence as a function of plasma column length in a soft x-ray amplifier,<sup>247</sup> a result that is important for achieving a very good spatial coherence in cavity-less soft x-ray lasers. Several theoretical studies had predicted such improvement of the spatial coherence with amplifier length as a result of gain guiding and refractive antiguiding that decrease the number of modes guided along an amplifier column.<sup>248,249</sup> In the capillary discharge pumped Ne-like Ar laser, the spatial coherence was measured recording the diffraction produced when the soft x-ray laser beam intersects a knife edge (Fig. 17, top), a technique developed by Rus and first utilized by Albert *et al.*<sup>250</sup> to measure the coherence of a laser pumped Ne-like Zn laser. Figure 17 (bottom) shows the measured diffraction patterns corresponding to capillary plasma lengths between 8 and 16.4 cm, and compares them to the results of a wave optics model. The improvement of the coherence with amplifier length is evident in the increased fringe visibility observed in the diffraction patterns corresponding to the longer plasma columns. Figure 18 shows results of a quantitative analysis of these data. The coherence is observed to increase mono-

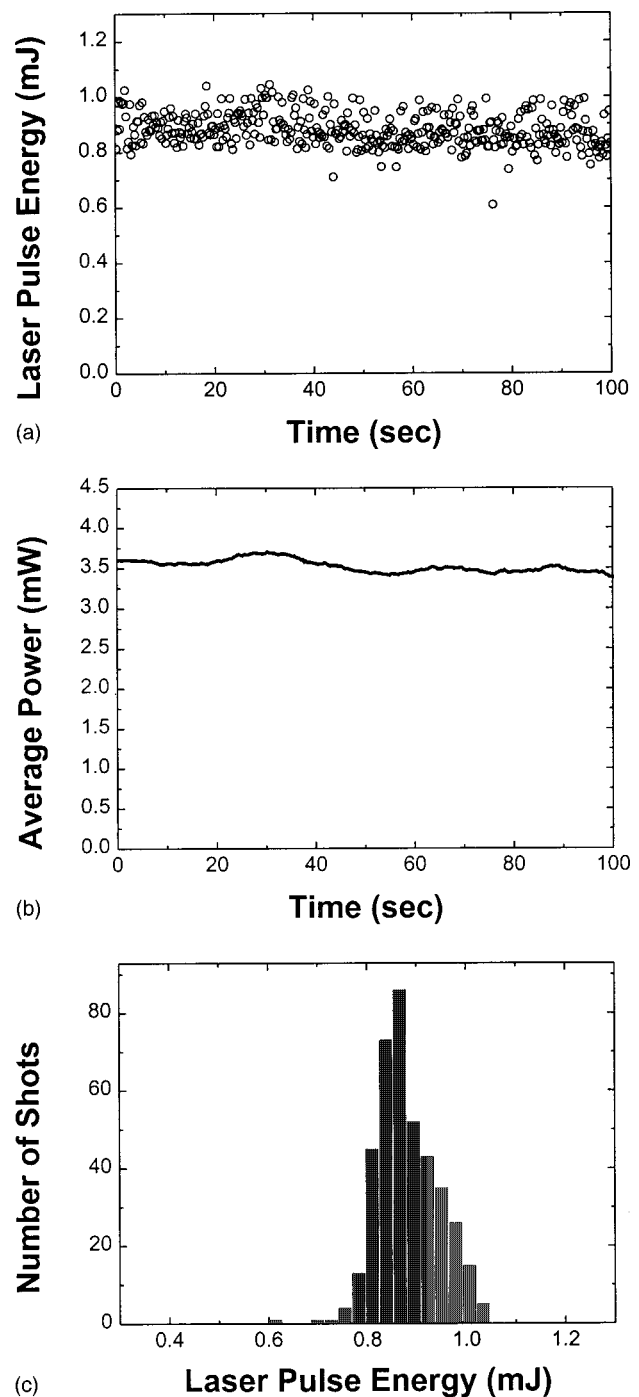

FIG. 15. Measured output pulse energy and average output power of a table-top capillary discharge 46.9 nm laser operating at a repetition frequency of 4 Hz. (a) Shot-to-shot laser output pulse energy. (b) Average output power computed as a walking average of 60 contiguous laser pulses. (c) Distribution of the output pulse energy. The average pulse energy is 0.88 mJ and the standard deviation is  $\pm 0.06$  mJ (from Macchietto *et al.*, Ref. 18).

tonically with capillary length, in good agreement with the result of the wave-optics calculations. For the longest capillaries studied, 16.4 cm, the coherence length in the tangential direction was determined to be about 4.5 mm in a plane situated at 5.9 m from the exit of the amplifier. This corresponds to an effective coherence angle of  $\approx 0.8$  mrad, and to a beam that is approximately six times diffraction limited in the tangential direction. Off-axis measurements showed that

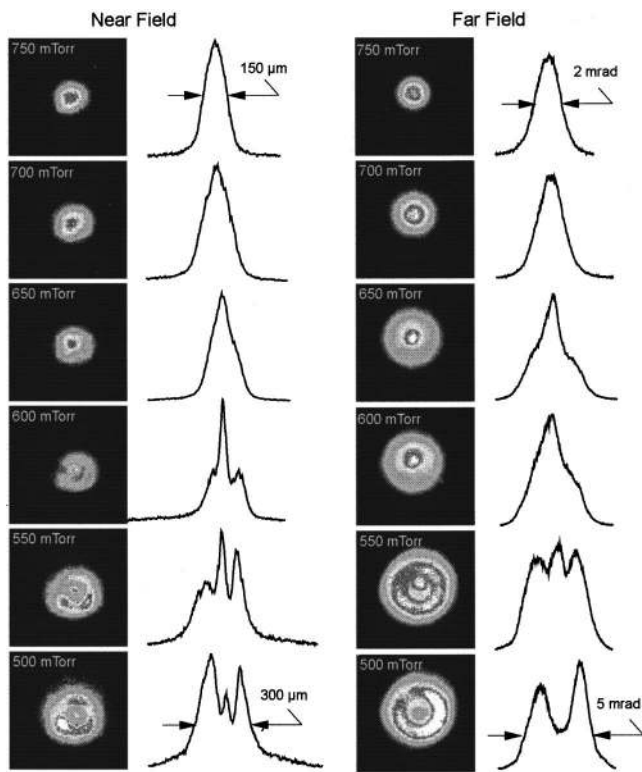

FIG. 16. Near-field and far-field patterns of a capillary discharge Ne-like Ar laser beam as a function of capillary discharge pressure. Diametral cuts with normalized intensities are shown at the left of each image. The measurements correspond to discharges in a 16.4 cm long, 4 mm diam polyacetal capillary excited by a 37 kA current pulse (from Moreno *et al.*, Ref. 97).

the coherence length in the radial direction is 30%–50% shorter than in the tangential direction.<sup>247</sup> Wave-model computations suggest that a likely cause of the observed anisotropy of the spatial coherence is the change of the electron density during the laser pulse. The observed monotonic increase of the spatial coherence with plasma column length is an additional corroboration of the very high axial plasma uniformity that is obtained in fast capillary discharges.

### 3. Lasing in Ne-like S in vapor created by discharge ablation and scaling to shorter wavelengths

The capillary discharge Ne-like Ar amplification results were extended to Ne-like S by Tomasel *et al.*, with the demonstration of a gain-length product of 7.5 in the  $3s^1P_1^0-3p^1S_0$  line at 60.84 nm.<sup>124</sup> This experiment demonstrated that large amplification in discharge created plasmas can be also obtained in elements that are solid at room temperature, a situation that will be frequently encountered in attempts to extend this scheme to shorter wavelengths. To obtain amplification in Ne-like S, the discharge setup illustrated in Fig. 8 was modified to allow for the injection of the sulfur vapor into the capillary channel through a hole in the ground electrode. The sulfur vapor was produced ablating the wall of an auxiliary capillary channel, drilled in a sulfur rod, with a slow current pulse delivering 200 J in about 50  $\mu$ s. The vapor generated by this capillary discharge was injected into the main capillary channel where it was subsequently excited by a fast current pulse having a first half-cycle duration of  $\sim 72$  ns. Strong amplification was observed

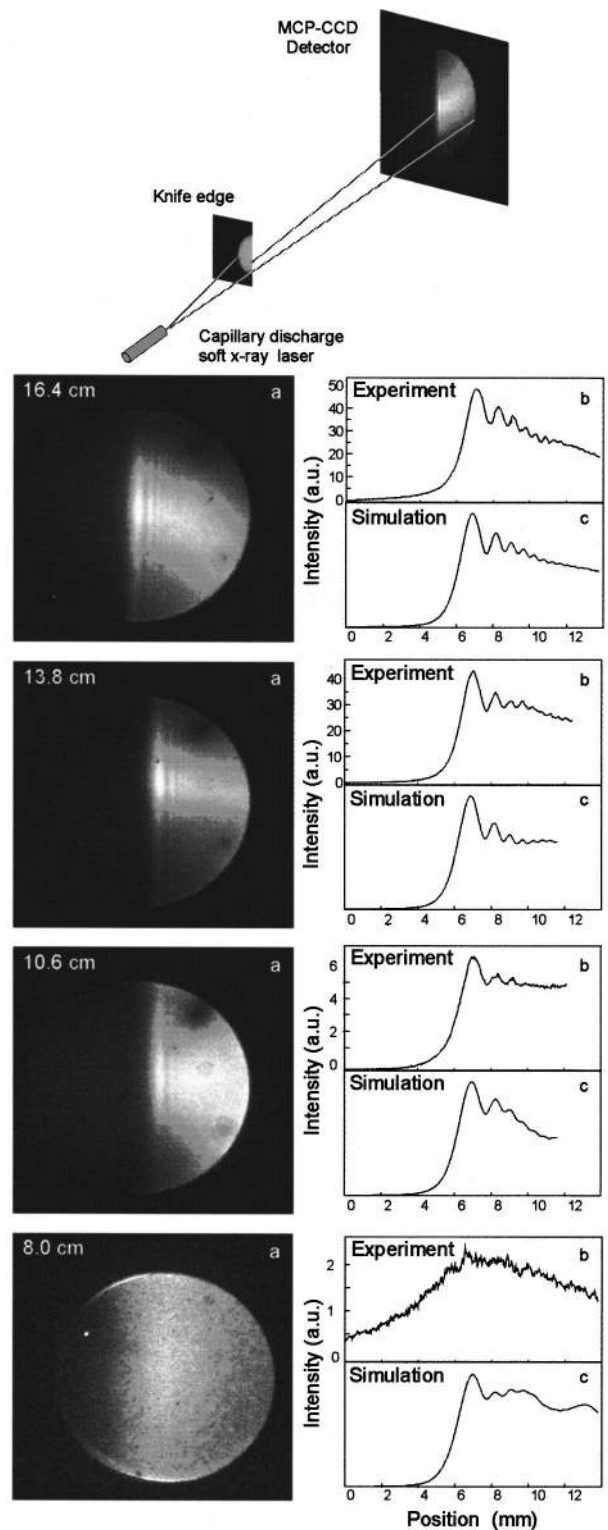

FIG. 17. (Top) Schematic representation of the setup used to measure the spatial coherence of a Ne-like Ar capillary discharge laser. (Bottom) (a) Measured diffraction patterns corresponding to different plasma column lengths. (b) Cross sections of (a). (c) Corresponding diffraction patterns computed using a wave-optics model (from Marconi *et al.*, Ref. 247).

for a broad range of pressures, from 300 to 700 mTorr, and for currents between 33 and 38 kA. Figure 19(a) shows a spectrum obtained under optimized conditions for amplification. The spectrum is completely dominated by the  $J=0-1$  line transition of Ne-like S, which appears at 60.84

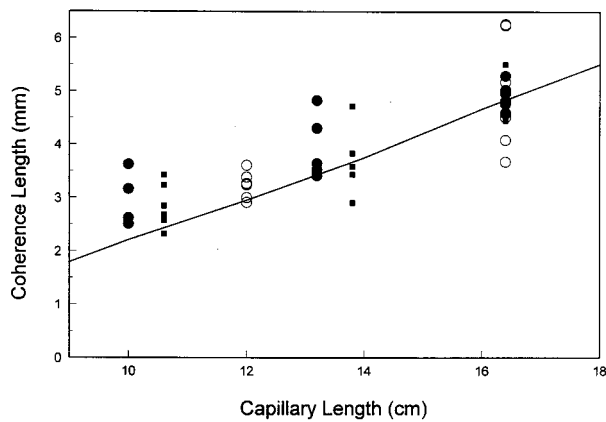

FIG. 18. Variation of the spatial coherent length of a 46.9 nm capillary discharge Ne-like Ar laser as a function of plasma column length. The line is the result of a wave-optics model calculation (from Marconi *et al.*, Ref. 247).

$\pm 0.015$  nm. Another line of Ne-like S, the  $3p^1P_1-3d^1P_1^0$  transition at 60.12 nm that in the absence of amplification should have similar intensity, also falls in the spectral range of Fig. 19(a). The fact that the intensity ratio of these two lines is observed to be at least 100 is clear evidence of amplification of the  $J=0-1$  line. Figure 19(b) shows the measured increase of the laser line intensity as a function of plasma column length. It corresponds to a gain coefficient of  $0.45 \text{ cm}^{-1}$ , and to a gain-length product of 7.5 for 16.8 cm long capillaries. Lasing occurs shortly before stagnation of the plasma column, in a gain region of about  $300 \mu\text{m}$  in diameter as in the case of Ne-like Ar. The deceleration of the plasma column near the axis prior to stagnation results in a velocity gradient that, due to motional Doppler broadening, considerably facilitates the radial escape of the lower laser level radiation. At the time of lasing, the electron density and temperature in the gain region are computed to be about  $(2-3) \times 10^{18} \text{ cm}^{-3}$  and 60–80 eV, respectively. This temperature corresponds to a plasma that is overheated with respect to the temperature range of  $T_e = 20-40$  eV for maximum Ne-like S abundance in a steady-state plasma. Due to the exponential dependence of the excitation rates on the electron temperature, the overheating causes a larger population inversion and, consequently, a larger gain than that attainable in steady state. Such overheating of the plasma with respect to steady-state ionization conditions can be more easily achieved in low- $Z$  elements like S, due to a large decrease of the ionization time with ion charge. In addition, in this sulfur laser transient population effects are found to play a more important role than in the argon laser. While in these relatively long-lived discharge plasmas transient effects are not nearly as dramatic as in plasmas produced by picosecond lasers, the computations indicate that in the case of the discharge-pumped sulfur laser experiment transient population effects can increase the gain by 20%–40%.<sup>124</sup>

Scaling of collisionally excited capillary discharge lasers to wavelengths shorter than 46.9 nm will require the use of elements heavier than Ar and higher excitation power densities. The scaling of plasma conditions and pump requirements for lasing at wavelengths as short as 10 nm have been

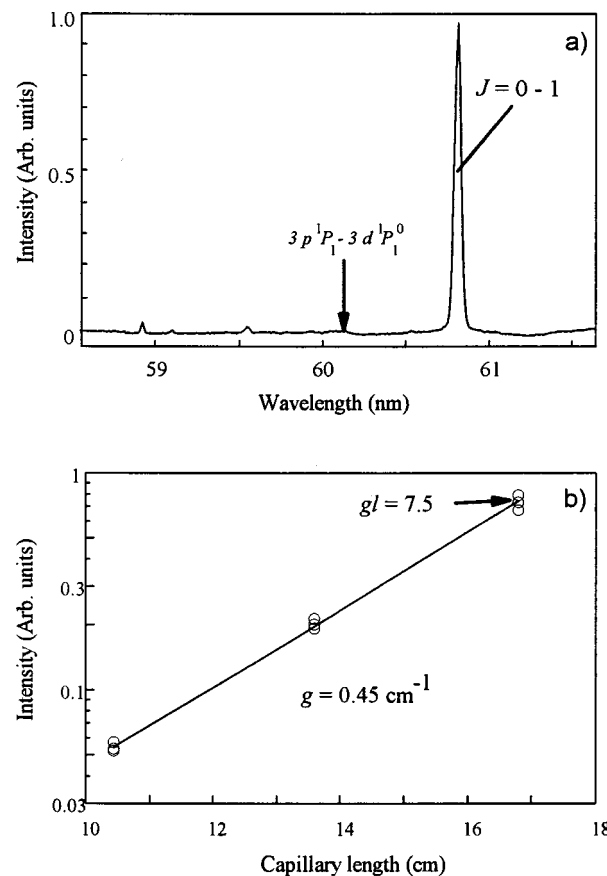

FIG. 19. (a) Spectrum of the axial emission of a capillary discharge in S. The amplified 60.8 nm  $3s^1P_1^0-3p^1S_0$  line of Ne-like S completely dominates the spectrum, while the 60.12 nm  $3p^1P_1-3d^1P_1^0$  line of the same ion (that in the absence of amplification should have similar intensity) is not observed. (b) Measured variation of the integrated line intensity of the 60.8 nm  $J=0-1$  line of Ne-like S as a function of plasma column length (from Tomasel *et al.*, Ref. 124).

estimated.<sup>82</sup> In most cases, this will require the use of elements that are solid at room temperature. The necessary vapor density can be produced using discharge ablation or vaporization methods.<sup>69,124,239,251-253</sup> The same pulse generator used to saturate the  $J=0-1$  line of Ne-like Ar was employed to conduct preliminary experiments in capillaries containing Ca and Ti. The spectra obtained yielded a clear identification of emission from the laser lines in Ne-Like Ca and a possible identification of the  $J=0-1$  laser line in Ne-like Ti.<sup>69</sup> Recently, current pulses of up to 200 kA peak amplitude and  $\approx 10$  ns rise time were used to explore the generation of capillary plasma columns with the conditions necessary for amplification at shorter wavelengths.<sup>242</sup>

#### 4. Gain in discharge-pumped recombination systems

The recombination scheme has the potential advantage of allowing for a more rapid scaling of discharge-pumped amplifiers to shorter wavelengths. Evidence of gain has been reported in several discharge-pumped recombination laser experiments.<sup>151-155,66</sup> However, in all cases only small exponentiation ( $gl < 4$ ) has been observed to date, with the laser line intensity remaining of the same order as that of sur-



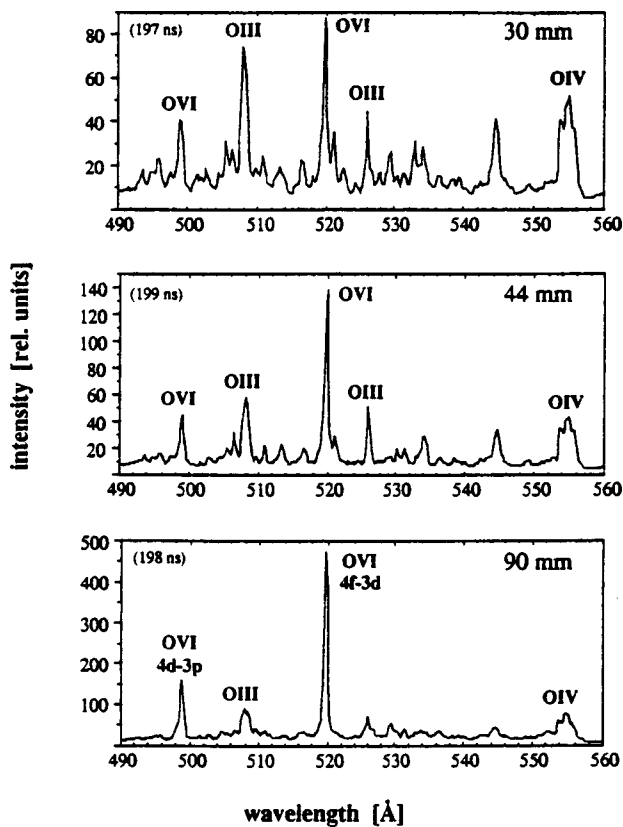

FIG. 20. Spectra of the axial emission of an oxygen Z-pinch plasma as a function of plasma column length. A nonlinear increase of the intensity in the 52 nm  $4f-3d$  line of Li-like O line is observed during plasma recombination (from Wagner *et al.*, Ref. 153).

rounding nonlasing lines emitted by the plasma. Such a small increase in the line intensity complicates the interpretation of the results and the verification of gain in recombination laser experiments. This is because in recombination systems the laser lines can be intense even when no amplification is present, and phenomena such as end effects that affect the axial homogeneity of the plasma parameters can influence the intensity dependence with plasma column length.

The possibility of obtaining amplification by collisional recombination in capillary discharge plasmas was proposed by Rocca *et al.* in 1988, who analyzed the case of amplification at 18.2 nm in the 3-2 line of H-like C.<sup>228</sup> Early experiments by Marconi and Rocca conducted in a LiH capillary observed an increase in the intensity of the 3-2 line of H-like Li in the recombination phase of a plasma.<sup>233</sup> Similar results in H-like Li were later obtained by Pöckl *et al.*, who also conducted gain experiments in Li-like O.<sup>254</sup> Several subsequent experiments were conducted in capillary discharges with the goal of obtaining amplification in the 18.2 nm line of C VI.<sup>66,151,152,234</sup> Steden and Kunze reported as evidence of gain the observation of short spikes in the intensity of the 18.2 nm line of H-like C, occurring at the time of maximum current during the second half-cycle of the current.<sup>151,255</sup> The experiments were conducted using polyacetal capillaries excited by a low-energy discharge pulse of 240 ns period. The intensity of the spikes increased with the capillary length, although not exponentially as it would be expected for the case of a constant gain coefficient.<sup>151</sup> Attempts to observe

these spikes in similar setups at other institutions were unsuccessful,<sup>234-236</sup> and spectroscopic studies suggested that the plasma conditions do not satisfy those required for the observation of amplification by collisional recombination in H-like C.<sup>235,236</sup> Kunze *et al.* later suggested that the spikes could be amplified spontaneous emission due to charge exchange between C VII ion streams created in the neck region of an  $m=0$  instability and C III and C V ions present in the colder surrounding regions.<sup>255</sup> Experiments conducted at Colorado State University showed that a much stronger 18.2 nm C VI emission can be obtained in polyethylene capillaries.<sup>66,234</sup> Polyethylene capillaries excited by fast current pulses (11 ns rise time, 40 ns half-cycle duration) yielded time-resolved spectra in which anomalously large intensity ratios between the 18.2 nm (3-2) and 13.5 nm (4-2) lines of H-like C are indicative of amplification.<sup>66</sup> However, these experiments did not show a reproducible supralinear increase of the laser line intensity with capillary length. Shin *et al.*<sup>152</sup> subsequently reported evidence of amplification of the 18.2 nm H-like C line in polyethylene capillaries 1.2 mm in diameter excited by a current pulse of 220 ns half-cycle duration, generated discharging a 120 nF capacitor charged to 17-27 kV. Time-integrated spectra showed an exponential growth of the laser line intensity for capillary lengths between 0.8 and 1.6 cm, corresponding to a gain coefficient of  $2.8 \text{ cm}^{-1}$ . The supralinear increase of the line intensity was observed to level off for plasma lengths longer than 1.6 cm, and to be present only in the first few discharges of newly prepared capillaries. Recently, Dussart *et al.* conducted experiments in a similar ablated polyethylene capillary discharge and reported the observation of a small superlinear increase in the C VI Balmer- $\alpha$  and - $\beta$  lines.<sup>152</sup>

Gain following plasma recombination has also been reported in several Z-pinch plasmas. Experiments performed by Glenzer and Kunze utilizing a gas-liner plasma pinch yielded evidence of gain in the  $4f-3d$  lines of O VI and F VII at 52.0 and 38.2 nm, respectively.<sup>154</sup> Measurements of amplification as a function of plasma length are difficult to perform in this device, and were not reported. Instead, the gain was inferred from the ratio of axial and radial line intensities. For O VI this ratio was observed to be indicative of a gain-length product of 4.5. In the case of F VII measurements were only conducted in the radial direction, and the existence of line enhancement was inferred from the ratio of the intensities of the  $4f-3d$  and  $4d-3p$  lines. The strongest amplification was reported to occur always at times shortly before maximum pinch compression. Pinhole pictures of the plasma revealed the existence of Rayleigh-Taylor instabilities. Collisional recombination was suggested as the mechanism most probably responsible for the observed line enhancements, but a possible influence of instabilities was not ruled out.<sup>154</sup> Wagner *et al.* obtained axial emission spectra of an oxygen Z pinch that show a small supralinear increase of the intensity of the  $4f-3d$  and  $4d-3p$  lines of Li-like O at 52.0 and 49.8 nm as a function of plasma length up to 9 cm.<sup>153</sup> From these data, shown in Fig. 20, gain-length products of about 2.5 and 2.2 were reported for each of these two lines, respectively. The supralinear increase of the intensity of these lines occurred about 45 ns after the maximum compression, during

the expansion of the plasma. This time delay is consistent with the interpretation of amplification by collisional recombination. Amplification experiments in the isoelectronic equivalent of these lines in Li-like Ne at 29.2 nm and 28.2 nm were performed by Böss *et al.*<sup>155</sup> Discharges in 6 mm diam tubes yielded two fluorescence maxima in these lines, the second corresponding to excitation by recombination of He-like Ne ions. The observation of a relative increase of the second intensity maxima with respect to the first in longer plasma columns, and the narrowing of its temporal profile were reported as evidence of gain. However, a measurement of exponential growth of the intensity of these laser lines with plasma column length has not yet been reported.

In summary, several recombination laser experiments in discharge-created plasmas have yielded indications of amplification. However, in all the experiments the maximum amplification obtained to date has been small. Additional efforts are required to increase the amplification to the level necessary for the development of a practical laser.

## B. Laser pumped by ultrashort pulse lasers

### 1. Collisionally excited Pd-like Xe laser in an optical-field-ionized plasma

Lemoff *et al.* realized in 1994 the first demonstration of a collisionally excited laser in an OFI plasma, obtaining a gain of  $gl \approx 11$ –12 in the 41.8 nm line of Pd-like Xe.<sup>75</sup> In this experiment, an intense circularly polarized femtosecond optical laser pulse was used to simultaneously create the highly ionized lasing ions and the hot pumping electrons. In this excitation method, originally suggested by Burnett and Corkum,<sup>256</sup> tunneling ionization strips the atoms to create the ground-state ions in the ionization stage of interest, and produces electrons with sufficient energy to collisionally excite these ions to the upper laser level. Lemoff, Barty, and Harris proposed the implementation of this scheme in eight time ionized gases to obtain amplification in lines in the 30–50 nm wavelength region.<sup>257</sup> In the successful Pd-like Xe experiment the excitation was provided by circularly polarized laser pulses with an energy of 70 mJ and a duration of 40 fs generated by a CPA Ti: sapphire laser operating at 10 Hz. The radiation of the pump laser was longitudinally focused onto a Xe gas target to tunnel ionize the atoms to the Pd-like ionization stage and to simultaneously produce the hot electrons necessary to collisionally excite the laser upper level. Figure 21 illustrates the differentially pumped gas target used in the experiment. The gas target was implemented by continuously admitting Xe gas into a cell provided with  $<500 \mu\text{m}$  diam pinholes for the entrance and exit of the pump laser beam and for the exit of the amplified soft x-ray radiation. The gas cell was placed inside a main vacuum chamber that was continuously pumped to maintain a pressure of less than  $2 \times 10^{-3}$  Torr. In this way, the femtosecond laser pulses were allowed to propagate in a nearly gas-free region until immediately before entering the gas cell that contained up to 12 Torr of Xe. The pinholes were placed on translation stages to conveniently change the gas target length, allowing for the measurement of the amplification as

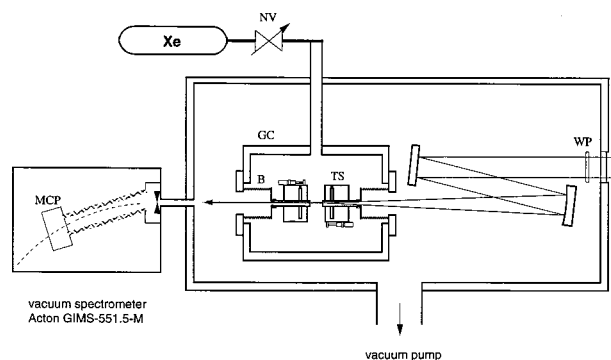

FIG. 21. Schematic illustration of the gas target setup used to obtain lasing in Pd-like Xe at 41.8 nm in a plasma created by optical field induced ionization. Excitation was provided by circularly polarized laser pulses with an energy of 70 mJ and a duration of 40 fs from a CPA Ti:sapphire laser operating at 10 Hz (from Lemoff *et al.*, Ref. 75).

a function of plasma length. The pump laser was circularly polarized by a mica quarter waveplate and was focused by a 50 cm focal length mirror to an intensity  $>3 \times 10^{16} \text{ W/cm}^2$  over a length of at least 7.4 mm.

Figures 22(a) and 22(b) show spectra corresponding to Xe target pressures of 3 and 12 Torr respectively. The 12 Torr spectrum shows an increase of more than 2 orders of magnitude in the recorded integrated intensity of the 41.8 nm laser line with respect to the 3 Torr spectra, a clear indication of amplification. A more direct measurement of the gain was obtained from the variation of the intensity of the laser line as a function of gas target length. The result of this measurement is shown in Fig. 23. The gain coefficient was estimated at  $13.3 \text{ cm}^{-1}$  using the Linford formula,<sup>87</sup> corresponding to a gain-length product  $gl = 11.2$  for an estimated target length of 8.4 mm. When the range was limited to the data from 3.9 to 7.4 mm (dashed line), a better fit was obtained with a gain coefficient of  $16.8 \text{ cm}^{-1}$  and  $gl = 12.4$  for a 7.4 mm target. Subsequent experiments determined that to achieve a high gain it is critical to avoid a significant prepulse in the femtosecond laser pulse.<sup>258</sup> The laser pulse width was not measured. However, at the operating pressure of 12 Torr, the 16.5 nm line radiation that links the laser lower level to the ground state is trapped, with an estimated absorption length of less than  $0.1 \mu\text{m}$ . This forces the stimulated emission to self-terminate after a time interval on the order of the upper-state lifetime, estimated at about 3.4 ps at 12 Torr.<sup>75</sup>

This collisionally excited OFI laser has the advantage of requiring a low excitation energy, allowing for high repetition rate operation. Amplification at a repetition rate of 10 Hz was already demonstrated in the successful proof-of-principle experiment conducted at Stanford.<sup>75</sup> A remaining challenge in the development of this laser scheme is the further increase of the amplification required to generate the practical output pulse energies that will enable its use in applications. This will most likely require a method to channel the tightly focused pump laser beam over longer distances using a waveguide. Scaling of this scheme to shorter wavelengths will require higher intensities of the pump pulse. For example, lasing in Ni-like Xe at  $\approx 10 \text{ nm}$  will require a laser intensity of about  $5 \times 10^{18} \text{ W cm}^{-2}$ . Alternatively, it has been proposed that this scheme could be scaled

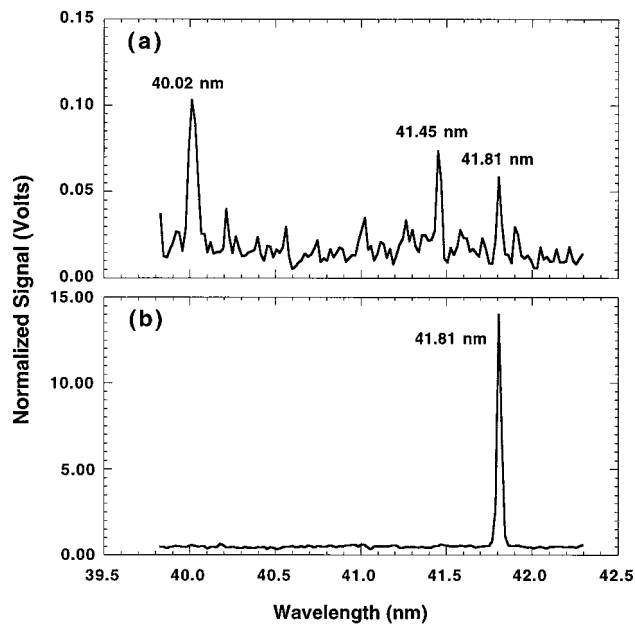

FIG. 22. Data showing the amplification of the 41.8 nm line of Pd-like Xe in a plasma created by optical field induced ionization; (a) and (b) are spectra corresponding to Xe target pressures of 3 and 12 Torr, respectively. (c) Variation of the integrated intensity of the 41.8 nm line of Pd-like Xe as a function of gas target length (from Lemoff *et al.*, Ref. 75).

to shorter wavelengths utilizing Be-like ions.<sup>259</sup>

## 2. Amplifiers based on recombination of an optical-field-ionized plasma

Amplification has been observed at 13.5 nm in the 2–1 transition of H-like Li in recombining plasmas ionized by a strong optical field.<sup>72,74,260,261</sup> The gain obtained in different experiments ranges from  $gl \approx 4$  (Ref. 72) to  $gl \approx 6.5$ .<sup>260</sup> The first observation of amplification in an OFI plasma was reported in this transition by Nagata *et al.*<sup>72</sup> The setup of the initial OFI recombination laser experiment conducted at the RIKEN (Japan) in 1993 is schematically illustrated in Fig. 24. A cold plasma of totally ionized Li ions was generated in two steps. First, a plasma of singly ionized Li ions was produced by line focusing a 20 ns KrF laser pulse with an energy of 200 mJ onto a rotating lithium target located in an evacuated chamber. Second, after a selected time delay, the plasma was optical-field ionized with a pulse of 50 mJ en-

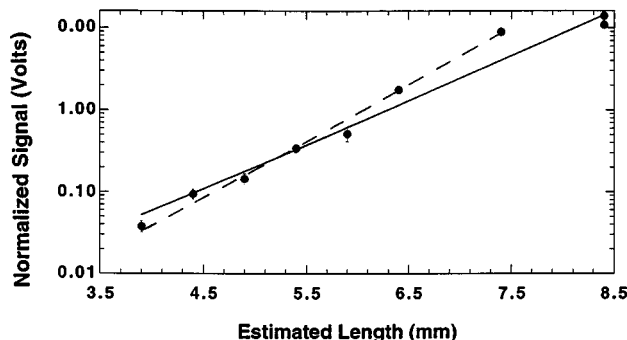

FIG. 23. Variation of the integrated intensity of the 41.8 nm line of Ni-like Pd as a function of Xe gas target length in a plasma created by optical field induced ionization (from Lemoff *et al.*, Ref. 75).

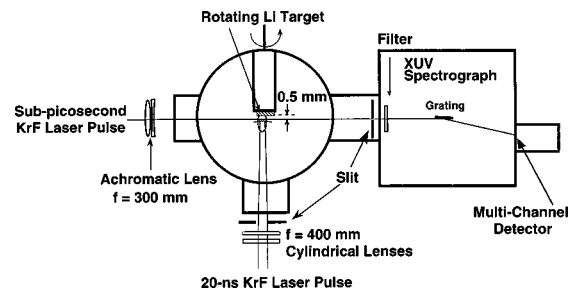

FIG. 24. (a) Schematic illustration of the experimental setup used at RIKEN in the observation of amplification in the 13.5 nm line of H-like Li in a plasma created by optical field induced ionization (from Nagata *et al.*, Ref. 72).

ergy from a linearly polarized subpicosecond (0.5 ps) KrF laser pulse. The subpicosecond laser pulse was longitudinally focused to an intensity of  $1 \times 10^{17} \text{ cm}^{-2}$ , at a distance of 0.5 mm from the target surface. The Lyman series emission from the H-like Li ions was detected with a flat field grazing incidence spectrograph. Figure 25 shows the measured variation of the 13.5 nm laser line intensity with plasma length, from which a gain coefficient of  $20 \text{ cm}^{-1}$  was deduced. The 13.5 nm radiation pulse was measured to have a FWHM duration of less than 20 ps, with the peak intensity occurring about 20 ns after the pump laser pulse.<sup>261</sup> This delay suggests that the laser upper level is not directly populated by the pump laser, but by collisional relaxation processes following collisional recombination. However, since the maximum plasma length was only 2 mm, the resulting gain-length product was limited to  $gl \approx 4$ . Similar experiments conducted at Princeton also using a KrF laser pump,<sup>179</sup> and at Berkeley using the second harmonic of a Ti:sapphire laser<sup>178</sup> confirmed the nonlinear growth of the intensity of the Lyman- $\alpha$  transition of H-like Li observed at RIKEN. Nevertheless, in all three experiments the maximum amplification length was limited to about 2 mm by the difficulty of propagating the radiation in the plasma, due to ionization-induced refraction. This is a limitation of the confocal geometry that, as a result of maximum intensity on axis, induces the highest degree of ionization and electron density on-axis. Approaches to overcome this problem have been suggested, and include the generation of very flat transverse intensity profiles,<sup>178</sup> and the generation of plasma waveguides with a minimum density on axis.<sup>74,119–121</sup> Progress in the implementation of the latter approach was reported by Korobkin *et al.*,<sup>74</sup> who used the setup illustrated in Fig. 26 to increase the amplification length to 5 mm by performing a plasma waveguide in a LiF microcapillary tube. A plasma with a minimum electron density on-axis was generated by ablation of the capillary walls with a 100 mJ, 5 ns pulse of 1.06  $\mu\text{m}$  wavelength radiation from a Nd/YAG laser loosely focused on the entrance of the microcapillary. Following a time delay of several hundred nanoseconds, the plasma was further ionized with a laser pulse of  $\approx 50$  mJ energy and 250 fs duration from a KrF excimer laser that was tightly focused at the entrance of the microcapillary. The observed increase of the intensity of the 13.5 nm line of H-like Li as a function of length is shown in Fig. 27, and corresponds to  $gl \approx 5.5$ .<sup>74</sup> These results were obtained at a repetition rate of 2 Hz.



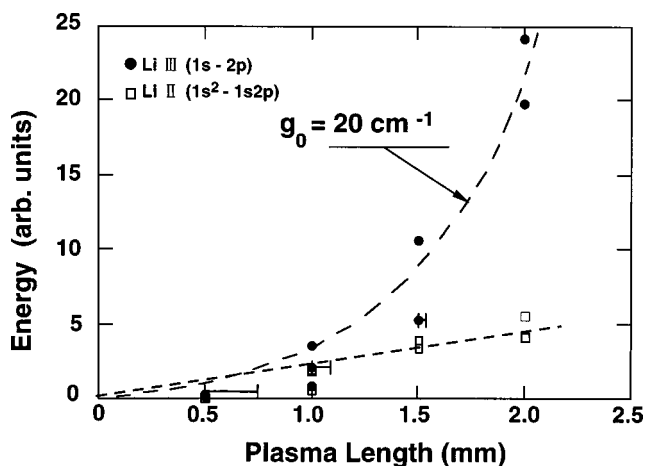

FIG. 25. Results of amplification experiment in the 2-1 line of H-like Li in a plasma created by optical field induced ionization. Intensities of the 13.5 nm line of H-like Li and 19.9 nm line of He-like Li as a function of plasma column length. The dashed curve is a calculated increase corresponding to a small-signal gain coefficient of  $20 \text{ cm}^{-1}$  (from Nagata *et al.*, Ref. 72).

Gain by recombination in an OFI plasma has also been reported in other ions. Chichkov *et al.* investigated amplification in transitions to the ground states in low-charge ions: O II, O III, C III, and N III.<sup>262</sup> A motivation for the study of amplification in these ions was their larger ratio of statistical weights between the lower and upper laser levels ( $g_1/g_2 \approx 1$ ), which is more favorable for the generation of population inversion. The ions of interest were produced by OFI of O<sub>2</sub>, CO<sub>2</sub>, and N<sub>2</sub> gases in gas jets using 80 mJ pulses from a 150 fs Ti:sapphire laser. Evidence of amplification was observed in the  $2p2s^3P-2p^2^3P$  transition of O III ( $\lambda = 37.4 \text{ nm}$ ) and in the  $2p^23s^2P-2p^3^2D$  line of O II ( $\lambda = 61.7 \text{ nm}$ ). The data suggest gain coefficients as high as  $25 \text{ cm}^{-1}$ , but again the overall amplification was small due to the small length of the gas targets. Recently, Chichkov *et al.* have questioned the interpretation of the H-like Li OFI amplification experiments based on the possible existence of Li clusters.<sup>175</sup> However, additional experiments are needed to confirm this hypothesis.

In summary, the OFI laser recombination scheme in transitions to the ground state has been reported to generate amplification at wavelengths as short as 13.5 nm with laser excitation energies of only 50 mJ. The small excitation energies are compatible with the requirement for the generation of high repetition rate table-top soft x-ray lasers. However, the remaining challenge in realizing a practical OFI laser is the increase of the gain-length product from the reported values of  $\leq 6.5$  to the larger values necessary to achieve practical output energies. Predictions of the output pulse energies that can be expected of OFI lasers range from  $1 \mu\text{J}$  (Ref. 178) to  $10\text{--}20 \mu\text{J}$ .<sup>260</sup> The OFI recombination scheme can in principle also be scaled to shorter wavelengths by using ions with higher ionization potentials. This could be implemented using more intense optical fields, provided that parametric electron heating effects (mainly stimulated Raman backscattering) are not found to be a limitation.

**3. Transient inversion collisional lasers**

The recent availability of relatively compact multiterawatt ultrashort-pulse optical laser systems with output ener-

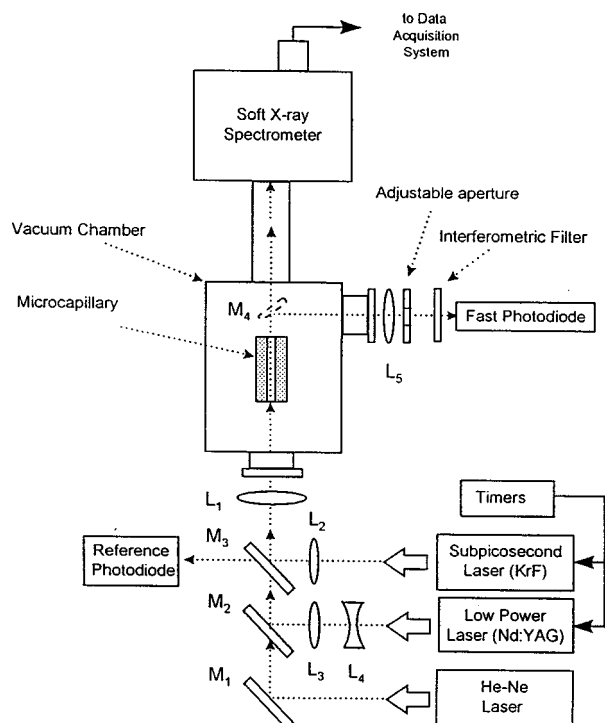

FIG. 26. Schematic illustration of the experimental setup used at Princeton in the creation of an OFI plasma in LiF microcapillaries for the observation of amplification in the 13.5 nm line of H-like Li (from Korobkin *et al.*, Ref. 74).

gies of several Joules has opened the opportunity to demonstrate soft x-ray lasing by transient electron collisional excitation.<sup>76-78,263</sup> This approach has allowed researchers to reduce the size of high gain laser-pumped soft x-ray collisional lasers from that of fusion-type laser facilities to the space occupied by a few optical tables. The implementation of transient inversion lasers is based on a two-step excitation

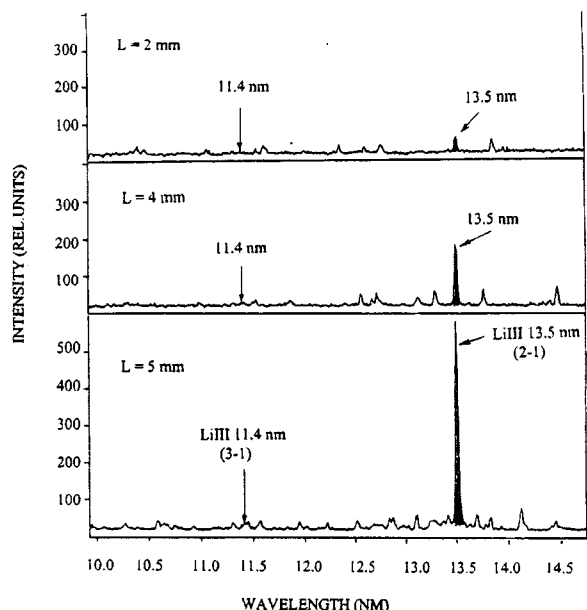

FIG. 27. (a) Axial spectra of an OFI plasma created in a LiF microcapillary using the setup shown in Fig. 26. The  $n=2-1$  transition of H-like Li at 13.5 nm is observed to increase as a function of plasma length with a gain coefficient of  $11 \text{ cm}^{-1}$  (from Korobkin *et al.*, Ref. 74).

sequence. First, a long scale length plasma containing the active ions must be prepared, since the inversion lifetime is usually shorter than the ionization time. This also allows for the elimination of the micron-scale plasma density gradients that are created when a solid target is irradiated with a single ps pulse. The experiments reported to date have used a first laser pulse with a duration on the order of 1 ns and energy of several Joules.<sup>76–78</sup> Second, after a time delay selected to optimize the degree of ionization, electron density, and density gradients, the plasma is rapidly heated with a picosecond or subpicosecond laser pulse. The ultrashort pulse rapidly increases the electron temperature to match or exceed that corresponding to the excitation energy of the laser upper level, generating the transient inversion.

The first demonstration of amplification by transient inversion was realized by Nickles *et al.* in the 32.6 nm  $3p-3s$   $J=0-1$  line of Ne-like Ti.<sup>76</sup> The experiment was performed at the Max Born Institute using the hybrid CPA Ti-sapphire/Nd:glass pump laser diagrammatically illustrated in Fig. 7. This laser system delivers synchronized long and short laser pulses of  $\approx 1.2$  ns and 0.7 ps duration, respectively. A dual cylindrical lens optics system was used to line focus the two beams onto the target with a width of 30  $\mu\text{m}$  over lengths of 1–5 mm. The diagnostics system consisted of a transmission grating and a streak camera. No laser pulse was observed as long as only one of both laser pulses was used. The first observation of gain was realized with short pulses of more than 2 J and long pulses of more than 3 J. Figure 28(a) shows a streak camera record of the spectrally and temporally resolved plasma emission in the 10–50 nm spectral region for a 5 mm long plasma created with pump intensities of  $10^{12}$  and  $10^{15}$  W/cm<sup>2</sup> for the long and short pulse, respectively. The bright and short spot at the top corresponds to strong amplification of the 32.6 nm of Ne-like Ti. The soft x-ray laser pulse was measured to have a duration of less than 20 ps. Weaker lasing was also observed in a line near 30 nm. This second laser line was identified as the  $3d-3p$   $J=1-1$  transition of Ne-like Ti. The inversion in this line is made possible by the reabsorption of the  $3d^1P_1-2p^1S_0$  transition.<sup>192,193</sup> Figure 28(b) illustrates the measured growth of the intensity of the 32.6 nm laser line as a function of plasma column length, for plasmas as long as 5 mm. Despite the large statistical fluctuations a nonlinear increase is clearly observed. It was analyzed to correspond to an average gain of 19 cm<sup>-1</sup> and to a gain-length product of  $\approx 9.5$ .<sup>76</sup> This gain coefficient is about seven times larger than that previously reported for the same line in the quasisteady state regime when pumped by a 0.6 ns duration pulse with an energy of 200–500 J.<sup>103</sup> These transient inversion Ne-like Ti results were reproduced and further improved by Dunn *et al.* at Lawrence Livermore National Laboratory (LLNL), who reported a gain-length product of 14 in this laser line and also obtained amplification at 25.5 nm using Ne-like Fe.<sup>78</sup> The size of the system utilized by Dunn *et al.* is that illustrated in Fig. 29, which depicts the layout of the Compact Multipulse Terawatt laser facility (COMET) at LLNL. The pump laser occupies two 1.2 m  $\times$  3.6 m optical tables with a total area of less than 10 m<sup>2</sup>. It is a 15 TW hybrid laser system consisting of a Ti:sapphire oscillator tuned to 1050 nm wavelength and

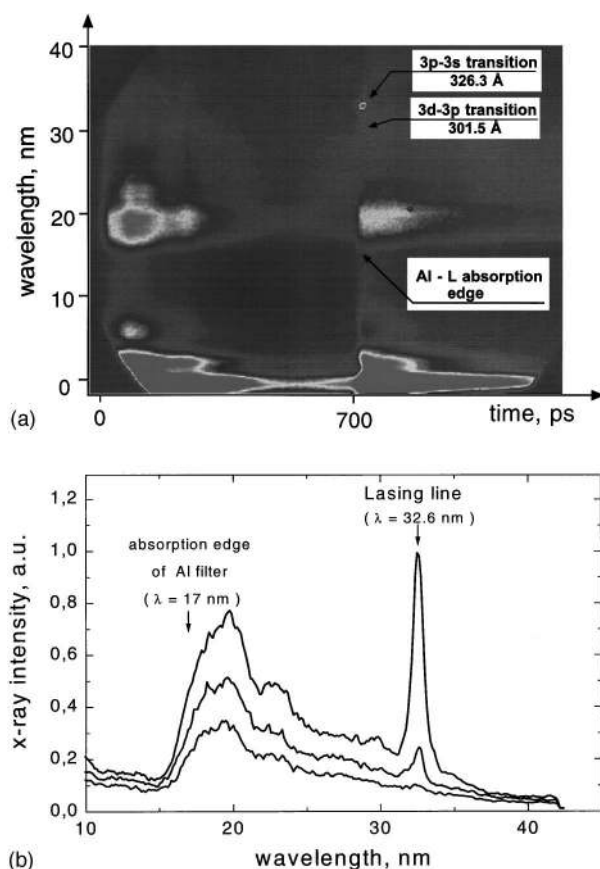

FIG. 28. (a) Results of transient inversion soft x-ray amplification experiment in Ne-like Ti. Spectrally resolved streak from a 5 mm long Ti plasma produced as the result of a sequence of a long (1.5 ns, 5 J) and short (0.7 ps, 2.6 J) laser pulses. The intense, short duration emission at 32.6 nm corresponds to the  $3p-3s$   $J=0-1$  line of Ne-like Ti and is the result of strong amplification. (b) Nonlinear growth of the 32.6 nm laser line intensity with plasma lengths of 2, 3, and 5 mm (from Nickles *et al.*, Ref. 76).

four-stage Nd-phosphate glass amplifiers. It generates two synchronized laser pulses of 7.5 J in 500 fs and 15 J in 600 ps at a repetition rate of one shot every 4 min. In some of the experiments the compressor gratings were detuned to produce 1 ps pulses. Typically 50 shots on target are achieved in a day.

Transient collisional excitation experiments conducted at Rutherford Laboratories with  $\approx 15$  J of short-pulse excitation energy from the Vulcan laser facility saturated the 32.6 nm line of Ne-like Ti and the 19.6 nm of Ne-like Ge.<sup>263</sup> While this pump laser is not a table-top system, a measurement of the laser output intensity versus pump energy suggested that saturation of the Ne-like Ti line could also be achieved with a short-pulse excitation energy of  $\approx 5$  J. The soft x-ray laser output energy was measured to be  $\approx 20$   $\mu\text{J}$ , corresponding to an efficiency of  $2 \times 10^{-6}$ .

The transient collisional scheme was also extended to shorter wavelengths utilizing the Ni-like sequence.<sup>77,78</sup> Dunn *et al.* reported a gain of up to 35 cm<sup>-1</sup> and a gain-length product of 12.5 in the  $4d^1S_0-4p^1P_1$  line of Ni-like Pd at 14.7 nm. In this experiment, the plasma was formed irradiating a slab target with a sequence of two laser pulses: a 5 J pulse of 800 ps duration followed by a 5 J pulse of 1.1 ps duration. The spectrum in Fig. 30(a) shows the increase of

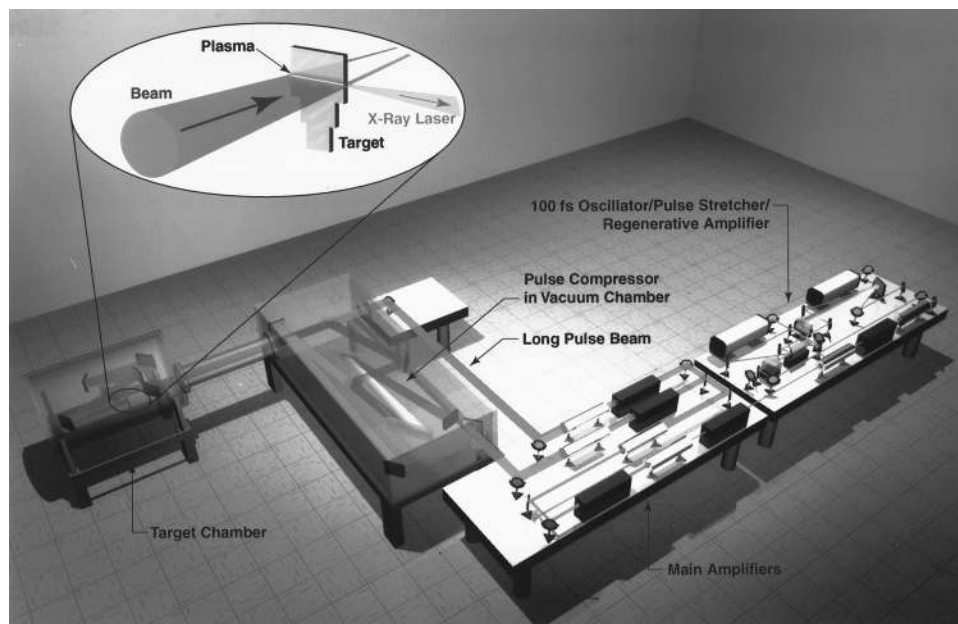

FIG. 29. Schematic illustration of the CPM pump laser system and target chamber used to produce transient inversion collisional soft x-ray lasers at Lawrence Livermore National Laboratory. The pump laser occupies two standard optical tables of dimensions  $1.2 \text{ m} \times 3.6 \text{ m}$  with total area less than  $10 \text{ m}^2$ . The system can be fired once every 4 min (Courtesy of J. Dunn, LLNL).

the 14.7 nm line intensity observed when the target length was increased from 1 to 3 mm. The measured increase of the integrated laser line intensity for target lengths up to 8 mm is shown in Fig. 30(b). The gain coefficient for lengths between 1 and 2 mm is about  $35 \text{ cm}^{-1}$ . The gain coefficient continuously decreases to reach a value of  $3.9 \text{ cm}^{-1}$  for target lengths above 7 mm. The overall gain-length product was estimated at 12.5 by continuously calculating the gain and integrating it over the full 8 mm target length. This smooth decrease of the gain with target length has been observed in all transient collisional excitation experiments and resembles gain saturation. However, it is mainly a consequence of transient time effects that cause a gradual decrease of the gain as the x-ray laser beam propagates through the plasma. Model computations suggest the transient gain is very inhomogeneous in space and time, reaching values of  $200 \text{ cm}^{-1}$  during the first 2 ps and rapidly decreasing to  $28 \text{ cm}^{-1}$  by 10 ps [Fig. 30(c)].<sup>77</sup> The highest gain occurs in a thin layer near the critical density region while the lower gain is computed to occur in areas with a relatively flat, lower density profile at  $100\text{--}300 \mu\text{m}$  from the target surface. The short inversion lifetime decreases the photon effective amplification path in the high gain region to an axial length of only  $\sim 500 \text{ nm}$ . The model computations also suggest that refraction effects caused by density gradients normal to the target surface shift the x-ray laser beam out of the high density and high gain region for longer target lengths, contributing to the gradual decrease of the gain.<sup>77</sup> As a consequence of these effects, the lower density regions are more adequate for amplification, in spite of the smaller local gain. Most recently the transient inversion scheme was extended to several Ni-like ions ranging from Y ( $\lambda = 24.01 \text{ nm}$ ) to Mo ( $\lambda = 18.89 \text{ nm}$ ) producing strong lasing on the  $4d^1S_0\text{--}4p^1P_1$  lines.<sup>216</sup> It can be expected that a large number of collisionally excited laser tran-

sitions will be demonstrated to lase in similar systems in the near future.

In summary, the transient excitation of preformed plasmas with high power ultrashort-pulse lasers has reduced by nearly 2 orders of magnitude the pump energy required to excite high-gain laser-pumped collisional soft x-ray lasers in Ne-like and Ni-like ions. This has greatly reduced the size of these lasers and has increased their repetition rate up to one shot every few minutes. It has been suggested that transient inversions driven with ultrashort-laser pulses with energies on the order of 10–20 J will lead to the realization of high gain x-ray lasers well below 10 nm, possibly reaching wavelengths within the “water window” (2.3–4.4 nm) region of the spectrum.<sup>76</sup> Future improvements in pumping efficiency resulting from optimized target configurations and traveling wave excitation can be expected to lead to saturated transient inversion soft x-ray lasers occupying a single optical table. (See notes added in proof, Dunn *et al.*)

### C. Lasers pump with long pulse lasers (50 ps–10 ns)

While in the last few years the majority of the efforts toward the development of laser-pumped table-top soft x-ray lasers has shifted to the use of ultrashort-pulse pump lasers,<sup>72,74–78,216</sup> significant gain has also been reported from experiments that used longer pump pulses, in the range of 50 ps–5 ns.<sup>73,79,80,264–272</sup> Recombination,<sup>73,80,264–269</sup> and collisional excitation schemes<sup>79,144,270–272</sup> excited by single or multiple laser pulses with pulse width ranging from 50 ps to 10 ns have been studied.

A series of experiments were conducted during the last 10 years at Princeton University toward the development of a small-scale recombination laser in the 18.2 nm line of C VI utilizing compact Nd-YAG lasers as the pump source.<sup>264–267</sup>



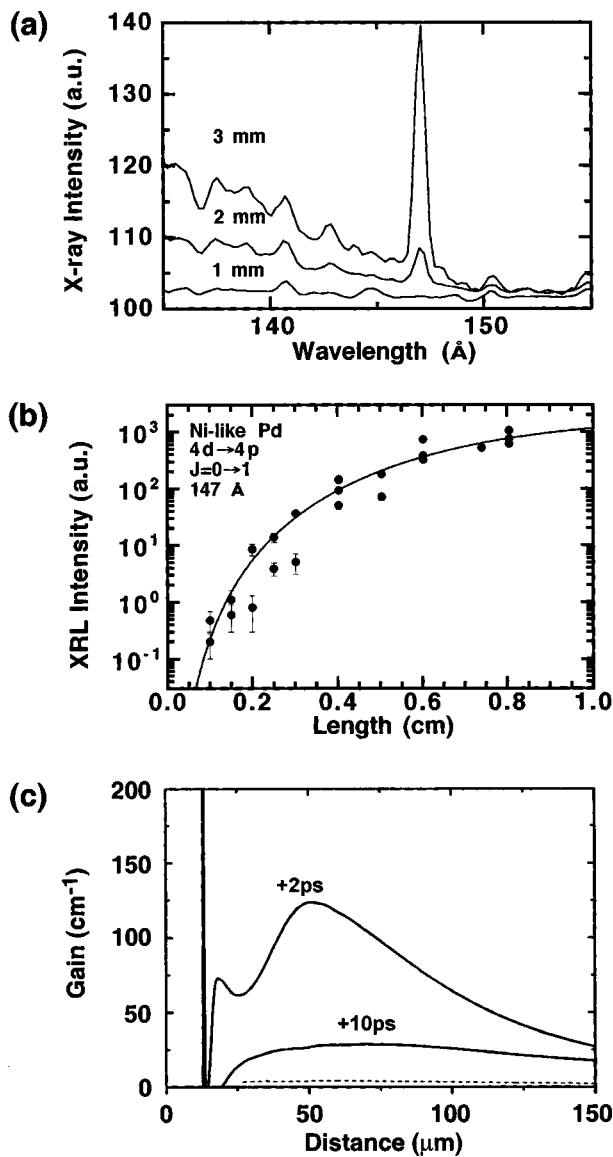

FIG. 30. Results of transient inversion soft x-ray amplification experiment in the  $4d-4p$   $J=0-1$  line of Ni-like Pd at 14.7 nm. (a) Spectra showing the increase of the intensity of the laser line as a function of target length. The intensity increases by more than 3 orders of magnitude when the target length is increased from 1 to 3 mm. (b) Measured intensity of the laser line as a function of target length. The continuous line is a guide through the experimental points. The data show the decrease of the transient gain as the x-ray laser propagates along the plasma column. (c) Computed transient gain profiles as a function of time measured from the arrival of a 1 ps excitation pulse (from Dunn *et al.*, Ref. 77).

In 1989 Kim *et al.* reported a gain of about  $8\text{ cm}^{-1}$  in that line as a result of an experiment that used a 25 J pump pulse of 3 ns duration, line focused into a 5 mm long solid carbon target.<sup>264</sup> In this experiment, a stainless steel blade was placed in proximity with the target to provide additional cooling by thermal conduction and by radiation from iron impurities. Later experiments obtained similar gain coefficients in 6 mm long targets with only 4 J of laser excitation energy using a multifin carbon target.<sup>266</sup> However, difficulties were found in increasing the amplification beyond a gain-length products  $\approx 5$ . The latest attempt in increasing the gain-length product in this line utilized a polyethylene microcapillary as target.<sup>267</sup> The Nd-YAG laser (2.5 J, 1.5 ns

pulse width in this experiment) was focused at the entrance of the microcapillary with the motivation of achieving guiding of the pump beam, plasma confinement, and plasma cooling by heat conduction to the walls. A gain-length product of about 5 was inferred from the intensity ratio of lines in the axial and perpendicular direction (the latter through small holes in the microcapillary walls). However, shot-to-shot intensity fluctuations prevented the verification of this result by the measurement of the increase in the laser line intensity with plasma column length.<sup>267</sup> In contrast, a similar experiment recently conducted in a  $\text{B}_2\text{O}_3$  microcapillary succeeded in observing amplification up to  $gl \approx 5$  in the 3-2 transition of H-like B at 26.2 nm.<sup>80</sup> The most remarkable aspect of this experiment is that pumping was done at 1 Hz with two low power lasers occupying a space of  $\approx 1.2 \times 3$  m in an optical table. The setup resembled that of the OFI H-like Li recombination laser experiment illustrated in Fig. 26, with the main difference that a 0.4 J, 8 ns Nd/YAG laser replaced the ultrashort-pulse KrF laser, making the arrangement considerably more compact. The preplasma was created by a 20 ns, 0.2 J KrF laser. The measured growth of the H-like B 26.2 nm line as a function of plasma length is shown in Fig. 31. Gain in this transition had been previously reported by Goodberlet *et al.*<sup>73</sup> who conducted table-top recombination laser experiments utilizing a shorter excitation pulse of 60 ps duration with an energy of about 0.7 J. A gain-length product of about 4 was reported in the 26.2 nm line of H-like B utilizing a target configuration with a cooling blade, similar to that used in some of the C VI experiments at Princeton. However, the authors later realized that the streak camera used in the experiments had a nonlinear intensity response, a fact that creates an uncertainty in the results.<sup>273</sup> Hara *et al.* realized the first experiments that utilized multiple pulse excitation from a pulse train to excite a recombination laser.<sup>268</sup> They have conducted a lengthy series of studies with the objective of developing a compact soft x-ray recombination laser based on a train of 100 ps pulses produced by a table-top Nd-YAG laser system.<sup>71,268,269</sup> In this case, the motivation for the use of a pulse train is a more efficient production of highly ionized ions and a faster termination of the excitation, determined by the dropoff of the last pulse. Experiments conducted utilizing 1.5–2 J of laser pulse energy to excite an 11 mm long Al slab target were reported to produce a gain coefficient of  $3.2\text{ cm}^{-1}$  in the 15.5 nm line of Li-like Al.<sup>71</sup> The latest results include double-pass experiments and multipass experiments that made use of unstable laser resonators constructed using Mo/Si multilayer mirrors. Evidence of cavity enhancement in the 15.5 and 15.1 nm lines of Li-like Al was observed.<sup>269</sup>

Significant efforts have also been devoted to reduce the size of collisional lasers using laser-pumped pulses of 50–500 ps duration. In 1988 Hagelstein<sup>138</sup> proposed to scale down the size of collisionally excited lasers by exciting low-Z Ni-like ions with 1–2 J pump pulses and predicted substantial transient gains. An experiment was implemented to demonstrate gain near 20 nm using a series of 60 ps laser pump pulses.<sup>270,271</sup> This initial attempt to scale down the size of laser-pumped collisionally excited soft x-ray lasers to a single optical table was also one of the first experiments to

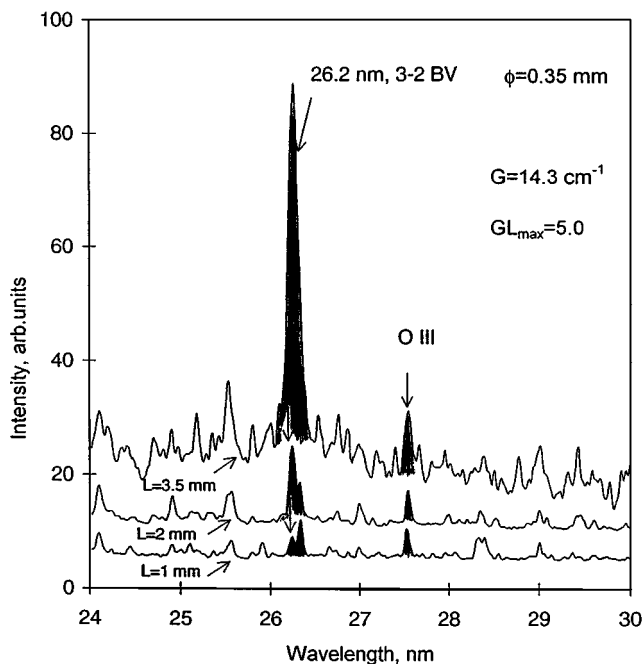

FIG. 31. Result of amplification experiment in the 3-2 line of H-like B ( $\lambda = 26.2$  nm) using a plasma created by a sequence of two low power laser pulses in a  $B_2O_3$  microcapillary plasma. The on-axis spectra for plasma lengths of 1, 2, and 3.5 mm show the nonlinear increase of the 26.2 nm laser line (from Korobkin *et al.*, Ref. 80).

use multiple-pulse excitation. The pump pulses were generated by a laser consisting of a mode-locked  $Q$ -switched Nd:YLF laser, followed by a preamplifier and a slab amplifier. Line-focus excitation of a Nb target was reported to result in gains of about  $3\text{ cm}^{-1}$  and  $gl \approx 3$  in the 20.4 nm line of Ni-like Nb. Similar experiments using the neighboring elements identified emission from the candidate laser line in Ni-like Mo (18.9 nm) and Ni-like Zr (22.1 nm).<sup>271</sup> More recently, Balmer *et al.* have reported the observation of large amplification in Ne-like ions irradiating slab targets with  $\sim 100$  J pulses of 500 ps duration produced by a Nd:glass laser that occupies a laboratory area of about  $9 \times 4$  m.<sup>79,272</sup> These experiments made use of the prepulse technique that had been successfully used to increase the efficiency of collisional lasers excited by laboratory-size laser pumps.<sup>103-117</sup> The  $3p-3s$   $J=0-1$  lines of Ti, Cr, Fe, Ni, and Zn were amplified to reach an intensity at least an order of magnitude larger than the background radiation using a prepulse with 0.7% of the total laser pump energy that preceded the main pulse by 5 ns. For the 32.6 nm line of Ti, the 25.5 nm line of Fe, and the 23.1 nm line of Ni gain coefficients between 4.2 and  $3.6\text{ cm}^{-1}$  were obtained for 2.4 cm long curved targets, resulting in gain length products of about 10.<sup>79</sup> Angle-resolved spectra indicated a typical beam divergence of about 3 mrad FWHM. At a recent conference, the same group has reported saturation of the 25.5 nm line of Ne-like Fe and also saturation of the 14.0 and 14.7 nm lines of Ni-like Ag and Ni-like Pd, respectively.<sup>144</sup> These latest results in Ni-like ions were obtained using a sequence of a single 8% prepulse followed after 1 ns by a main excitation pulse of  $\approx 30$  J, 100 ps. Gain-length products of 15.5 and 15.6 were obtained on flat Ag and Pd targets, respectively. A compar-

ative study of the influence of the Pd target surface roughness on the laser output performance indicated a substantial increase in laser output intensity for reduced roughness. Presently, the repetition rate of these soft x-ray lasers is about one shot every 30 min limited by the frequency of firing of the pump laser.

## VI. DISCUSSION AND FUTURE PROSPECTS

Remarkable progress has been achieved in the last few years in several critical aspects of the development of practical table-top soft x-ray lasers. It includes advances in both table-top laser-pumped and discharge-pumped devices. Laser-pumped soft x-ray lasers have reached saturation at wavelengths as short as 14 nm using only several Joule of excitation energy. Significant soft x-ray amplification has also been observed in several systems utilizing only a fraction of a Joule of laser excitation energy. A very compact 26.5 eV discharge-pumped laser has been operated at a repetition of several Hz producing millijoule-level laser pulses and an average power of 3.5 mW. This table-top laser produces a spatially coherent laser average power per unit bandwidth that is comparable to that generated by a third-generation synchrotron beam line, and a peak coherent power that is several orders of magnitude larger. The reduction in the size, cost, and complexity of soft x-ray lasers resulting from these developments will soon lead to the widespread use of these sources in numerous scientific and technological applications. Some table-top soft x-ray lasers have already emerged from their development stage to be used in applications. For example, a capillary discharge-pumped laser has been successfully utilized to perform soft x-ray plasma shadowgraphy and interferometry.<sup>246,274</sup> These experiments will soon be followed by an explosion in the number of applications of table-top soft x-ray lasers. Significant progress can also be expected in the next few years in the demonstration of compact practical lasers at increasingly shorter wavelengths as a result of the combination of compact high power ultrashort-pulse laser systems with transient inversion collisional schemes, or recombination lasing in transitions to the ground state. Moreover, the advent of relatively compact optical laser systems with output powers of up to 100 TW can be expected to result in the long awaited realization of  $K$ -shell photoionization lasers operating at extremely short wavelengths.

*Notes added in proof.* Since the submission of this Review Article, the proceedings of the latest International Conference on X-Ray Lasers have been published. "X-Ray Lasers 1998" *Proceedings of the 6th International Conference on X-Ray Lasers*, edited by Y. Kato, H. Takuma, and H. Daido (Institute of Physics, University of Berkshire, Reading, 1999). The proceedings of another recent conference "Soft X-Ray Lasers and Applications III," edited by J. J. Rocca and L. B. Da Silva, SPIE (Society of Photo-optical Engineers, Bellingham, WA, 1999), Vol. 3776, are in press.

At the recent conference "Soft X-Ray Lasers and Applications III," Denver, CO, 18-23 July 1999, Dunn *et al.* reported saturation of the 14.7 nm Ni-like Pd and 14.0 nm Ni-like Ag transient inversion collisional excitation lasers

using traveling wave excitation. The laser output pulse energy of the line of Ni-like Pd was reported to be approximately 10  $\mu\text{J}$  for 7 J of laser pump energy.

## ACKNOWLEDGMENTS

The author thanks J. Dunn, K. Frank, S. Harris, H. Kapteyn, R. London, K. Midorikawa, M. Murnane, P. Nickles, A. Osterheld, V. Shlyaptsev, and S. Suckewer for supplying the figures that illustrate their work. The useful comments of J. Chilla, R. Elton, C. S. Menoni, S. Suckewer, V. Shlyaptsev, and F. Tomasel are appreciated. In his own work in soft x-ray lasers the author acknowledges the collaboration of B. Benware, D. Beethe, D. Burt, J. Chilla, D. Clark, O. Cortázar, K. Floyd, M. Frati, J. Filevich, J. Gonzalez, D. Hartshorn, K. Kanizay, C. Macchietto, H. Mancini, M. Marconi, O. Martinez, C. Moreno, K. Richardson, V. Shlyaptsev, B. Szapiro, F. Tomasel, and A. Vinogradov. The assistance of B. Hutchenson with the mechanics of the manuscript is appreciated. The author also acknowledges the support of the National Science Foundation and the Department of Energy.

- <sup>1</sup> *Soft X-ray Lasers and Applications II*, edited by J. J. Rocca and L. B. Da Silva, Proc. SPIE (Society of Photooptical Engineers, Bellingham, WA, 1997), Vol. **3156**.
- <sup>2</sup> *X-Ray Lasers*, edited by S. Svanberg and C. G. Wahlstrom (Institute of Physics, University of Reading, Berkshire 1996), Vol. 1511.
- <sup>3</sup> *Soft X-Ray Lasers and Applications*, edited by J. J. Rocca and P. L. Hagelstein, Proc. SPIE (Society of Photooptical Engineers, Bellingham, WA, 1995), Vol. **2520**.
- <sup>4</sup> *X-Ray Lasers*, edited by D. C. Eder and D. L. Matthews (AIP, New York, 1994).
- <sup>5</sup> A. L'Huillier, in Ref. 2, p. 444 and references therein.
- <sup>6</sup> Z. Chang, A. Rundquist, H. Wang, M. M. Murnane, and H. C. Kapteyn, Phys. Rev. Lett. **79**, 2967 (1997).
- <sup>7</sup> A. Rundquist, C. G. Durfee III, Z. Chang, C. Herne, S. Backus, M. Murnane, and H. C. Kapteyn, Science **280**, 1412 (1998).
- <sup>8</sup> T. Ditmire, J. K. Crane, H. Nyugen, L. B. Da Silva, and M. D. Perry, Phys. Rev. A **51**, R902 (1995).
- <sup>9</sup> D. T. Attwood, K. Halbach, and N. J. Kim, Science **228**, 1264 (1985).
- <sup>10</sup> D. T. Attwood, G. Sommargren, R. Beguiristain, K. Nguyen, J. Boker, N. Ceglie, K. Jackson, M. Koike, and J. Underwood, Appl. Opt. **32**, 7022 (1993).
- <sup>11</sup> R. Coisson, Appl. Opt. **34**, 904 (1995).
- <sup>12</sup> J. Rossback, in Ref. 2, p. 436.
- <sup>13</sup> *Free-Electron Laser Challenges*, edited by P. G. O'Shea and H. E. Bennett, Proc. SPIE (Society of Photooptical Engineers, Bellingham, WA, 1997), Vol. **2988**.
- <sup>14</sup> P. L. Shkolnikov and A. E. Kaplan, in Ref. 2, p. 512 and references therein.
- <sup>15</sup> L. B. Da Silva *et al.*, Phys. Rev. Lett. **74**, 3991 (1995); A. S. Wan, T. W. Barbee Jr., R. Cauble, P. Celliers, L. B. Da Silva, J. C. Moreno, P. W. Rambo, G. F. Stone, J. E. Trebes, and F. Weber, Phys. Rev. E **55**, 6293 (1997).
- <sup>16</sup> R. Cauble, L. B. Da Silva, T. W. Barbee Jr., P. Celliers, J. C. Moreno, and A. S. Wan, Phys. Rev. Lett. **74**, 3816 (1995).
- <sup>17</sup> B. R. Benware, C. D. Macchietto, C. H. Moreno, and J. J. Rocca, Phys. Rev. Lett. **81**, 5804 (1998).
- <sup>18</sup> C. D. Macchietto, B. R. Benware, and J. J. Rocca, Opt. Lett. **24**, 1115 (1999).
- <sup>19</sup> T. H. Maiman, Nature (London) **187**, 493 (1960); A. Javan, W. R. Bennett, Jr., and D. R. Herriot, Phys. Rev. **6**, 106 (1961).
- <sup>20</sup> G. A. Gudzenko and L. A. Shelepin, Zh. Eksp. Teor. Fiz. **45**, 1445 (1963) [Sov. Phys. JETP **18**, 998 (1964)].
- <sup>21</sup> M. A. Duguay and P. M. Rentzepis, Appl. Phys. Lett. **10**, 350 (1967).
- <sup>22</sup> A. G. Molchanov, Sov. Phys. Usp. **15**, 124 (1972).
- <sup>23</sup> R. C. Elton, Appl. Opt. **14**, 97 (1975).
- <sup>24</sup> A. N. Zherikin, K. N. Koshelev, and V. S. Letokhov, Sov. J. Quantum Electron. **6**, 82 (1976).
- <sup>25</sup> A. V. Vinogradov, I. I. Sobel'man, and E. A. Yukov, Sov. J. Quantum Electron. **7**, 32 (1977).
- <sup>26</sup> L. A. Vainshtein, A. V. Vinogradov, V. I. Safranova, and I. Vu. Skolev, Sov. J. Quantum Electron. **8**, 239 (1978).
- <sup>27</sup> A. V. Vinogradov and V. N. Shlyaptsev, Sov. J. Quantum Electron. **10**, 754 (1980), and **13**, 303 (1980).
- <sup>28</sup> W. B. Bridges, "Ionized gas lasers," in *Handbook of Laser Science and Technol. Sec. 2*, Vol. II, edited by M. J. Weber (Chemical Rubber Corp., Boca Raton, 1982).
- <sup>29</sup> M. A. Dunn and J. N. Ross, Prog. Quantum Electron. **4**, 233 (1976).
- <sup>30</sup> F. Irons and N. J. Peacock, J. Phys. B **7**, 1109 (1974).
- <sup>31</sup> R. J. Dewhurst, D. Jacoby, G. J. Pert, and S. A. Ramsden, Phys. Rev. Lett. **37**, 1265 (1976).
- <sup>32</sup> Y. A. Kononov, K. N. Koshelev, Yu. A. Levykin, Yu. V. Sidel'nikov, and S. S. Churilov, Sov. J. Quantum Electron. **6**, 308 (1976).
- <sup>33</sup> V. A. Bhagavatula and B. Yarkobi, Opt. Commun. **24**, 331 (1978).
- <sup>34</sup> R. H. Dixon and R. C. Elton, Phys. Rev. Lett. **38**, 1072 (1977).
- <sup>35</sup> M. H. Key, C. L. S. Lewis, and M. J. Lamb, Opt. Commun. **28**, 331 (1979).
- <sup>36</sup> P. Jaeglé, G. Jamelot, A. Carillon, and C. Wehenkel, Jpn. J. Appl. Phys., Part 1 **17**, 483 (1978).
- <sup>37</sup> D. Jacoby, G. J. Pert, S. A. Ramsden, L. D. Shorrock, and G. J. Tallents, Opt. Commun. **37**, 193 (1981); D. Jacoby, G. J. Pert, L. D. Shorrock, and G. J. Tallents, J. Phys. B **15**, 3557 (1982).
- <sup>38</sup> D. L. Matthews *et al.*, Phys. Rev. Lett. **54**, 110 (1985); M. D. Rosen, P. L. Hagelstein, D. L. Matthews, E. M. Campbell, A. U. Hazi, B. L. Whitten, B. MacGowan, R. E. Turner, and R. W. Lee, *ibid.* **54**, 106 (1985).
- <sup>39</sup> S. Suckewer, C. H. Skinner, H. Milchberg, C. Keane, and D. Voorhees, Phys. Rev. Lett. **55**, 1753 (1985); S. Suckewer, C. H. Skinner, D. Kim, E. Valeo, D. Voorhees, and A. Wouters, *ibid.* **57**, 1004 (1986).
- <sup>40</sup> T. N. Lee, E. A. McLean, and R. C. Elton, Phys. Rev. Lett. **59**, 1185 (1987).
- <sup>41</sup> C. Chenais-Popovics *et al.*, Phys. Rev. Lett. **59**, 2161 (1987).
- <sup>42</sup> B. J. MacGowan *et al.*, J. Appl. Phys. **61**, 5243 (1987).
- <sup>43</sup> B. J. MacGowan, S. Maxon, P. L. Hagelstein, C. J. Keane, R. A. London, D. L. Matthews, M. D. Rosen, J. H. Scofield, and D. A. Whelan, Phys. Rev. Lett. **59**, 2157 (1987).
- <sup>44</sup> B. J. MacGowan *et al.*, Phys. Fluids B **4**, 2326 (1992).
- <sup>45</sup> A. Carillon *et al.*, Phys. Rev. Lett. **68**, 2917 (1992).
- <sup>46</sup> J. A. Koch *et al.*, Phys. Rev. Lett. **68**, 3291 (1992).
- <sup>47</sup> B. Rus *et al.*, in Ref. 4, p. 293.
- <sup>48</sup> C. H. Skinner, D. S. Diccio, D. Kim, R. J. Rosser, S. Suckewer, A. P. Gupta, and J. G. Hirshberg, J. Microsc. **159**, 51 (1990).
- <sup>49</sup> L. B. DaSilva *et al.*, Science **258**, 269 (1992).
- <sup>50</sup> J. E. Trebes *et al.*, Science **238**, 517 (1987).
- <sup>51</sup> P. Jaeglé *et al.*, J. Appl. Phys. **81**, 2406 (1997); G. Jamelot *et al.*, in Ref. 1, p. 124.
- <sup>52</sup> R. W. Waynant and R. C. Elton, Proc. IEEE **64**, 1059 (1976).
- <sup>53</sup> P. L. Hagelstein, Plasma Phys. **25**, 1345 (1983); *Atomic Physics 9*, edited by R. S. Van Dyck, Jr. and E. N. Fortson (World Scientific, Singapore, 1984), p. 382.
- <sup>54</sup> C. J. Keane, Proc. SPIE **1551**, 2 (1991).
- <sup>55</sup> H. C. Kapteyn, L. B. Da Silva and R. W. Falcone, Proc. IEEE **80**, 342 (1992).
- <sup>56</sup> D. L. Matthews, Nucl. Instrum. Methods Phys. Res. B **98**, 91 (1995).
- <sup>57</sup> C. H. Skinner, Phys. Fluids B **3**, 2420 (1991).
- <sup>58</sup> R. C. Elton, *X-Ray Lasers* (Academic, Boston, 1990).
- <sup>59</sup> *Ultrashort Wavelength Lasers*, edited by S. Suckewer, Proc. SPIE (Society Photo-optical Engineers, Bellingham, WA, 1991), Vol. **1551**.
- <sup>60</sup> *X-Ray Lasers*, edited by E. E. Fill (Institute of Physics Press, Bristol, 1992).
- <sup>61</sup> *Ultrashort Wavelength Lasers II*, edited by S. Suckewer, Proc. SPIE (Society Photo-optical Engineers, Bellingham, WA, 1993), Vol. **2012**.
- <sup>62</sup> S. Backus, C. G. Durfee III, M. Murnane, and H. C. Kapteyn, Rev. Sci. Instrum. **69**, 1207 (1998).
- <sup>63</sup> C. P. J. Barty *et al.*, in Ref. 2, p. 282.
- <sup>64</sup> D. P. Umstadter, C. Barty, M. Perry, and G. A. Mourou, Opt. Photonic News **9**, 41 (1998).
- <sup>65</sup> Y. Kato, in Ref. 2, p. 274.
- <sup>66</sup> J. J. Rocca, M. C. Marconi, B. T. Szapiro, and J. Meyer, Proc. SPIE **1551**, 275 (1991).
- <sup>67</sup> R. C. Elton, J. D. Shipman, Jr., and F. C. Young, Conference Record Abstracts 1990 IEEE International Conference on Plasma Science 1990, p. 108.



- <sup>68</sup>J. J. Rocca, O. D. Cortázar, B. Szapiro, K. Floyd, and F. G. Tomasel, *Phys. Rev. E* **47**, 1299 (1993).
- <sup>69</sup>J. J. Rocca, O. D. Cortázar, F. G. Tomasel, and B. T. Szapiro, *Phys. Rev. E* **48**, R2378 (1993).
- <sup>70</sup>J. J. Rocca, M. C. Marconi, J. L. A. Chilla, D. P. Clark, F. G. Tomasel, and V. N. Shlyaptsev, *IEEE J. Sel. Top. Quantum Electron.* **1**, 945 (1995).
- <sup>71</sup>H. Hirose, T. Hara, K. Ando, F. Negishi, and Y. Aoyagi, *Jpn. J. Appl. Phys., Part 2* **32**, L1538 (1993); T. Hara, K. Ando, F. Negishi-Tsuboi, Y. Aoyagi, H. Hirose, and Y. Yashiro, *Proc. SPIE* **1627**, 377 (1992).
- <sup>72</sup>Y. Nagata, K. Midorikawa, S. Kubodera, M. Obara, H. Tashiro, and K. Tokoda, *Phys. Rev. Lett.* **71**, 3774 (1993).
- <sup>73</sup>J. Goodberlet, S. Basu, M. H. Nuendel, S. Kaushik, T. Savas, M. Fleury, and P. L. Hagelstein, *J. Opt. Soc. Am. B* **12**, 980 (1995).
- <sup>74</sup>D. Korobkin, C. H. Nam, S. Suckewer, and A. Golstov, *Phys. Rev. Lett.* **77**, 5206 (1996).
- <sup>75</sup>B. E. Lemoff, G. Y. Yin, C. L. Gordon III, C. P. J. Barty, and S. E. Harris, *Phys. Rev. Lett.* **74**, 1574 (1995); *J. Opt. Soc. Am. B* **13**, 180 (1996).
- <sup>76</sup>P. V. Nickles, V. N. Shlyaptsev, M. Kalashnikov, M. Schnurer, I. Will, and W. Sandner, *Phys. Rev. Lett.* **78**, 2748 (1997).
- <sup>77</sup>J. Dunn, A. L. Osterheld, R. Shepherd, W. E. White, V. N. Shlyaptsev, and R. E. Stewards, *Phys. Rev. Lett.* **80**, 2825 (1998).
- <sup>78</sup>J. Dunn, A. L. Osterheld, R. Shepherd, W. E. White, V. N. Shlyaptsev, A. Bullock, and R. E. Stewart, in *Ref. 1*, p. 114.
- <sup>79</sup>A. R. Parág, F. Löwenthal, R. Tommasini, and J. E. Balmer, *Appl. Phys. B: Lasers Opt.* **66**, 561 (1998).
- <sup>80</sup>D. Korobkin, A. Goltsov, A. Morozov, and S. Suckewer, *Phys. Rev. Lett.* **81**, 1607 (1998).
- <sup>81</sup>J. J. Rocca, V. Shlyaptsev, F. G. Tomasel, O. D. Cortázar, D. Hartshorn, and J. L. A. Chilla, *Phys. Rev. Lett.* **73**, 2192 (1994).
- <sup>82</sup>J. J. Rocca, F. G. Tomasel, M. C. Marconi, V. N. Shlyaptsev, J. L. A. Chilla, B. T. Szapiro, and G. Guidice, *Phys. Plasmas* **2**, 2547 (1995).
- <sup>83</sup>J. J. Rocca, D. P. Clark, J. L. A. Chilla, and V. N. Shlyaptsev, *Phys. Rev. Lett.* **77**, 1476 (1996).
- <sup>84</sup>Yu. A. Uspenskii *et al.*, *Opt. Lett.* **23**, 771 (1998).
- <sup>85</sup>T. W. Barbee, Jr., J. C. Rife, W. R. Hunter, M. P. Kowalski, R. G. Cruddace, and J. F. Seely, *Appl. Opt.* **32**, 4852 (1993).
- <sup>86</sup>A. D. Siegman, *Lasers* (University Science Books, Mill Valley, CA, 1986), p. 301.
- <sup>87</sup>G. J. Linfood, E. R. Peresini, W. R. Soor, and M. L. Spaeth, *Appl. Opt.* **13**, 379 (1974).
- <sup>88</sup>For typical gains in visible gas lasers, see for example, W. T. Silfvast, *Laser Fundamentals* (Cambridge University Press, Cambridge, 1996).
- <sup>89</sup>K. Kato *et al.*, *Proc. SPIE* **3156**, 2 (1997).
- <sup>90</sup>V. A. Chirkov, *Sov. J. Quantum Electron.* **14**, 1497 (1984).
- <sup>91</sup>R. A. London and M. D. Rosen, *Phys. Fluids* **29**, 3813 (1986).
- <sup>92</sup>R. A. London, *Phys. Fluids* **31**, 184 (1988).
- <sup>93</sup>E. E. Fill, *Opt. Commun.* **67**, 441 (1988).
- <sup>94</sup>P. B. Holden and B. Rus, *Opt. Commun.* **119**, 424 (1995).
- <sup>95</sup>J. L. A. Chilla and J. J. Rocca, *J. Opt. Soc. Am. B* **13**, 2841 (1996).
- <sup>96</sup>E. E. Fill, *J. Opt. Soc. Am. B* **14**, 1505 (1997).
- <sup>97</sup>C. H. Moreno, M. C. Marconi, V. N. Shlyaptsev, B. R. Benware, C. D. Macchietto, J. L. A. Chilla, J. J. Rocca, and A. Osterheld, *Phys. Rev. A* **58**, 1509 (1998).
- <sup>98</sup>J. C. Moreno, J. Nilsen, Y. Li, P. Lu, and E. E. Fill, *Opt. Lett.* **21**, 585 (1996).
- <sup>99</sup>J. Nilsen, J. C. Moreno, L. B. DaSilva, and T. W. Barbee, Jr., *Phys. Rev. A* **55**, 827 (1997).
- <sup>100</sup>J. Zhang *et al.*, *Phys. Rev. A* **54**, R4653 (1996).
- <sup>101</sup>J. C. Moreno, J. Nilsen, Y. L. Li, and E. E. Fill, *Opt. Lett.* **21**, 866 (1996).
- <sup>102</sup>J. Nilsen, J. C. Moreno, L. B. DaSilva, and T. W. Barbee, Jr., *Phys. Rev. A* **55**, 827 (1997).
- <sup>103</sup>I. T. Boehly *et al.*, *Phys. Rev. A* **42**, 6962 (1990).
- <sup>104</sup>J. Nilsen, B. J. MacGowan, L. B. Da Silva, and J. C. Moreno, *Phys. Rev. A* **48**, 4682 (1993).
- <sup>105</sup>J. Nilsen and J. C. Moreno, *Phys. Rev. Lett.* **74**, 3376 (1995).
- <sup>106</sup>G. Jamelot *et al.*, *Proc. SPIE* **2520**, 2 (1995).
- <sup>107</sup>G. F. Cairns, *et al.*, *Opt. Commun.* **124**, 777 (1996).
- <sup>108</sup>Y. Li, G. Pretzler, and E. E. Fill, *Phys. Rev. A* **52**, R3433 (1995); E. F. Fill, Y. Li, D. Schlögl, J. Steingruber, and J. Nilsen, *Proc. SPIE* **2520**, 134 (1995).
- <sup>109</sup>H. Daido, R. Kodama, K. Murai, G. Yuan, M. Takagi, Y. Kato, I. W. Choi, and C. H. Nam, *Opt. Lett.* **20**, 61 (1995).
- <sup>110</sup>B. Rus, A. Carillon, P. Dhez, P. Jaeglé, G. Jamelot, A. Klisnick, M. Nantel, and P. Zeitoun, *Phys. Rev. A* **55**, 3858 (1997).
- <sup>111</sup>H. Daido, S. Ninomiya, T. Imani, B. Kodama, M. Takagi, Y. Kato, K. Murai, J. Zhang, Y. You, and Y. Gu, *Opt. Lett.* **21**, 958 (1996).
- <sup>112</sup>E. E. Fill, Y. Li, D. Schlögl, J. Steingruber, and J. Nilsen, *Opt. Lett.* **20**, 374 (1995).
- <sup>113</sup>G. J. Tallents, *Proc. SPIE* **3156**, 30 (1997).
- <sup>114</sup>J. Zhang *et al.*, *Phys. Rev. Lett.* **78**, 3856 (1997).
- <sup>115</sup>J. Zhang *et al.*, *Science* **276**, 1097 (1997).
- <sup>116</sup>J. Zhang *et al.*, *Phys. Rev. A* **54**, R4653 (1996).
- <sup>117</sup>Y. L. Li, G. Pretzler, P. X. Lu, E. E. Fill, and J. Nilsen, *Phys. Plasmas* **4**, 479 (1997).
- <sup>118</sup>F. G. Tomasel, V. N. Shlyaptsev, and J. J. Rocca, *Phys. Rev. A* **54**, 2474 (1996).
- <sup>119</sup>C. G. Durfee III, J. Lynch, and H. M. Milchberg, *Phys. Rev. E* **51**, 2368 (1995).
- <sup>120</sup>H. M. Milchberg, C. G. Durfee III, and J. Lynch, *J. Opt. Soc. Am. B* **12**, 731 (1995).
- <sup>121</sup>C. G. Durfee III, J. Lynch, and H. M. Milchberg, *Opt. Lett.* **19**, 1937 (1994).
- <sup>122</sup>Y. Ehrlich, C. Cohen, A. Zigler, J. Krall, P. Sprangle, and E. Erasay, *Phys. Rev. Lett.* **77**, 4186 (1996).
- <sup>123</sup>J. J. Rocca, F. G. Tomasel, M. C. Marconi, J. L. A. Chilla, C. H. Moreno, B. R. Benware, V. N. Shlyaptsev, J. J. Gonzales, and C. D. Macchietto, *Proc. SPIE* **3156**, 164 (1997).
- <sup>124</sup>F. G. Tomasel, J. J. Rocca, V. N. Shlyaptsev, and C. D. Macchietto, *Phys. Rev. A* **55**, 1437 (1997).
- <sup>125</sup>Y. Li, P. Lu, G. Pretzler, and E. E. Fill, *Opt. Commun.* **133**, 196 (1997).
- <sup>126</sup>D. J. Fields *et al.*, *Phys. Rev. A* **46**, 1606 (1992).
- <sup>127</sup>G. J. Pert, *J. Phys. B* **9**, 3301 (1976).
- <sup>128</sup>B. L. Whitten, R. A. London, and R. S. Walling, *J. Opt. Soc. Am. B* **5**, 2537 (1988).
- <sup>129</sup>V. N. Shlyaptsev, J. J. Rocca, and A. L. Osterheld, *Proc. SPIE* **2520**, 265 (1995).
- <sup>130</sup>B. L. Whitten *et al.*, Interim Report of the  $J=0$  Task Force, Lawrence Livermore Lab. UCID-21152 (1987).
- <sup>131</sup>H. R. Griem, *Phys. Rev. A* **33**, 3580 (1986).
- <sup>132</sup>J. P. Apruzese, J. Davis, M. Blaha, P. C. Kepple, and V. L. Jacobs, *Phys. Rev. Lett.* **55**, 1877 (1985).
- <sup>133</sup>H. Fiedorowicz, A. Bartnik, Y. Li, P. Lu, and E. Fill, *Phys. Rev. Lett.* **76**, 415 (1996).
- <sup>134</sup>S. Maxon, P. Hagelstein, J. Scofield, and Y. Lee, *J. Appl. Phys.* **59**, 293 (1986).
- <sup>135</sup>S. Maxon, P. Hagelstein, B. MacGowan, R. London, M. Rosen, J. Scofield, S. Dalhed, and M. Chen, *Phys. Rev. A* **37**, 2227 (1988).
- <sup>136</sup>W. H. Goldstein, J. Oreg, A. Zigler, A. Bar-Shalom, and M. Klapisch, *Phys. Rev. A* **38**, 1797 (1988).
- <sup>137</sup>B. J. MacGowan, S. Maxon, C. J. Keane, R. A. London, D. L. Matthews, and D. A. Whelan, *J. Opt. Soc. Am.* **5**, 1858 (1988).
- <sup>138</sup>P. L. Hagelstein, *Proc. OSA Meeting on Short Wavelength Coherent Radiation: Generation and Applications*, edited by R. W. Falcone and J. Korz, 1988 p. 28; *Proc. SPIE* **1551**, 254 (1991).
- <sup>139</sup>B. J. MacGowan *et al.*, *Phys. Rev. Lett.* **65**, 420 (1990).
- <sup>140</sup>B. J. MacGowan *et al.*, *Phys. Rev. Lett.* **65**, 2374 (1990).
- <sup>141</sup>H. Daido *et al.*, *Phys. Rev. Lett.* **75**, 1074 (1995).
- <sup>142</sup>H. Daido *et al.*, *Opt. Lett.* **21**, 958 (1996).
- <sup>143</sup>J. Zhang *et al.*, *Proc. SPIE* **3156**, 53 (1997).
- <sup>144</sup>R. Tommasini, F. Löwenthal, and J. E. Balmer, in *X-ray Lasers 1998*, Proceedings of the 6th International Conference on X-ray Lasers, edited by Y. Kato, H. Takuma, and H. Daido (Institute of Physics, University of Berkshire, Reading, 1999); R. Tommasini, F. Löwenthal, and J. E. Balmer, *Phys. Rev. A* **59**, 1577 (1999).
- <sup>145</sup>V. N. Shlyaptsev, Ph.D. thesis, P. N. Lebedev, Physical Institute, 1987, Preprint FIAN #40 (1985).
- <sup>146</sup>Yu. A. Afanasiev and V. N. Shlyaptsev, *Sov. J. Quantum Electron.* **19**, 1606 (1989).
- <sup>147</sup>V. N. Shlyaptsev, P. V. Nickles, T. Schlegel, M. R. Kalashnikov, and A. L. Osterheld, *Proc. SPIE* **2012**, 111 (1993).
- <sup>148</sup>V. N. Shlyaptsev, J. J. Rocca, M. P. Kalashnikov, P. V. Nickles, W. Sandner, A. L. Osterheld, J. Dunn, and D. C. Eder, *Proc. SPIE* **3156**, 93 (1997).
- <sup>149</sup>C. D. Decker and R. A. London, *Proc. SPIE* **3156**, 94 (1997).
- <sup>150</sup>J. Nilsen, *Proc. SPIE* **3156**, 86 (1997).
- <sup>151</sup>C. Steden and H. J. Kunze, *Phys. Lett. A* **151**, 534 (1990).

- <sup>152</sup>H. J. Shin, D. E. Kim, and T. N. Lee, *Phys. Rev. E* **50**, 1376 (1994); R. Dussart, W. Rosenfeld, N. Richard, D. Hong, C. Cachoncinlle, C. Fleuriere, and J. M. Pouvesly, in *X-ray Lasers 1998*, Proceedings 6th International Conference on X-ray Lasers, edited by Y. Kato, H. Takuma, and H. Daido (Institute of Physics, University of Berkshire, Reading, 1999).
- <sup>153</sup>T. Wagner, E. Eberl, K. Frank, W. Hartmann, D. H. H. Hoffmann, and R. Thotz, *Phys. Rev. Lett.* **76**, 3124 (1996).
- <sup>154</sup>S. Glender and H. J. Kunze, *Phys. Rev. E* **49**, 1586 (1994).
- <sup>155</sup>T. Böss, W. Neff, T. Boboc, F. Weigand, R. Bischoff, and H. Langhoff, *J. Phys. D* **31**, 2472 (1998).
- <sup>156</sup>D. R. Bates and A. Dalgarno, in *Atomic and Molecular Processes*, edited by D. R. Bates (Academic, New York, 1962), p. 245.
- <sup>157</sup>F. V. Bunkin, V. I. Der Zhiev, and S. I. Yakovlenko, *Sov. J. Quantum Electron.* **11**, 981 (1981).
- <sup>158</sup>See, for example, Ref. 88, p. 256.
- <sup>159</sup>G. J. Pert, *J. Phys. B* **9**, 3301 (1976); A. K. Dave and G. J. Pert, *ibid.* **18**, 1027 (1985).
- <sup>160</sup>J. F. Seely, C. W. Brown, U. Feldman, M. Richardson, B. Yaakobi, and W. E. Behring, *Opt. Commun.* **54**, 289 (1985).
- <sup>161</sup>M. Grande *et al.*, *Opt. Commun.* **74**, 309 (1990).
- <sup>162</sup>B. Boswell, D. Shavarts, T. Boehly, and B. Yaakobi, *Phys. Fluids B* **2**, 436 (1990).
- <sup>163</sup>H. Azumma *et al.*, *Opt. Lett.* **15**, 1011 (1990).
- <sup>164</sup>G. Jamelot, A. Klisnick, A. Carillon, H. Guennov, A. Sureau, and P. Jaeglé, *J. Phys. B* **18**, 4647 (1998).
- <sup>165</sup>P. Jaeglé, G. Jamelot, A. Carrillon, A. Klisnick, A. Sureau, and H. Guennov, *J. Opt. Soc. Am. B* **4**, 563 (1987); A. Carillon *et al.*, *J. Phys. B* **23**, 147 (1990).
- <sup>166</sup>D. Kim, C. H. Skinner, A. Wouters, E. Valed, D. Voorhes, and S. Suckewer, *J. Opt. Soc. Am. B* **6**, 115 (1989).
- <sup>167</sup>H. Milchberg, C. H. Skinner, S. Suckewer, and D. Voorhes, *Appl. Phys. Lett.* **47**, 1151 (1985).
- <sup>168</sup>S. Suckewer and H. Fishman, *J. Appl. Phys.* **51**, 1922 (1980).
- <sup>169</sup>C. J. Keane and S. Suckewer, *J. Opt. Soc. Am. B* **8**, 201 (1991).
- <sup>170</sup>J. Steingruber, S. S. Chen, and E. E. Fill, in Ref. 60, p. 115.
- <sup>171</sup>G. J. Pert, in Ref. 4, p. 49.
- <sup>172</sup>W. W. Jones and A. W. Ali, *Appl. Phys. Lett.* **26**, 450 (1975).
- <sup>173</sup>J. Peyraud and N. Peyraud, *J. Appl. Phys.* **43**, 2993 (1972).
- <sup>174</sup>P. B. Corkum, N. H. Burnett, and F. Brunel, *Phys. Rev. Lett.* **62**, 1259 (1989).
- <sup>175</sup>B. N. Chichkov and B. Wellegehausen, in "X-ray Lasers 1998," Proceedings of the 6th International Conference on X-ray Lasers, edited by Y. Kato, H. Takuma and H. Daido (Institute of Physics, University of Berkshire, Reading, 1999).
- <sup>176</sup>N. H. Burnett and P. B. Corkum, *J. Opt. Soc. Am. B* **6**, 1195 (1989).
- <sup>177</sup>P. E. Amendt and D. C. Eder, *Phys. Rev. Lett.* **66**, 2589 (1991); D. C. Eder, P. Amendt, and S. C. Wilks, *Phys. Rev. A* **45**, 6761 (1992).
- <sup>178</sup>D. C. Eder *et al.*, *Phys. Plasmas* **1**, 1744 (1994).
- <sup>179</sup>P. Polonsky, C. O. Park, K. Krushelnick, and S. Suckewer, *Proc. SPIE* **2012**, 61 (1993).
- <sup>180</sup>H. C. Kapteyn, *Appl. Opt.* **31**, 4931 (1992).
- <sup>181</sup>G. L. Strobel, D. C. Eder, R. A. London, M. D. Rosen, R. W. Falcone, and S. P. Gordon, *Proc. SPIE* **1860**, 157 (1993).
- <sup>182</sup>R. C. Elton, *Appl. Opt.* **14**, 2243 (1975).
- <sup>183</sup>W. T. Silfvast, J. J. Macklin, and D. R. Wood II, *Opt. Lett.* **8**, 551 (1983); H. Lundbergt, J. J. Macklin, W. T. Silfvast, and O. R. Wood, *Appl. Phys. Lett.* **45**, 335 (1984).
- <sup>184</sup>E. J. McGuire, *Phys. Rev. Lett.* **35**, 844 (1975).
- <sup>185</sup>H. C. Kapteyn, R. W. Lee, and R. W. Falcone, *Phys. Rev. Lett.* **57**, 2939 (1986).
- <sup>186</sup>M. H. Sher, S. J. Benerofe, J. F. Young, and S. E. Harris, *J. Opt. Soc. Am. B* **8**, 114 (1991).
- <sup>187</sup>H. C. Kapteyn and R. W. Falcone, *Phys. Rev. A* **37**, 2033 (1988).
- <sup>188</sup>S. J. Moon, D. C. Eder, and G. L. Strobel, in Ref. 4, p. 262.
- <sup>189</sup>D. L. Matthews, in Ref. 2 p. 32.
- <sup>190</sup>A. Vinogradov, I. Sobel'man, and E. Yukov, *Sov. J. Quantum Electron.* **5**, 59 (1975).
- <sup>191</sup>B. A. Norton and N. J. Peacock, *J. Phys. B* **8**, 989 (1975).
- <sup>192</sup>J. Nilsen, H. Fiedorowicz, A. Bartnik, Y. L. Li, P. X. Lu, and E. E. Fill, *Opt. Lett.* **21**, 408 (1996).
- <sup>193</sup>J. Nilsen, *Phys. Rev. A* **53**, 4539 (1996).
- <sup>194</sup>J. Trebes and M. Krishnan, *Phys. Rev. Lett.* **50**, 679 (1983).
- <sup>195</sup>N. Qi, H. Kilic, and M. Krishnan, *Appl. Phys. Lett.* **46**, 471 (1985).
- <sup>196</sup>N. Qi and M. Krishnan, *Phys. Rev. Lett.* **59**, 2051 (1987); *Phys. Rev. A* **39**, 4651 (1989).
- <sup>197</sup>R. H. Dixon and R. C. Elton, *J. Opt. Soc. Am. B* **1**, 232 (1984).
- <sup>198</sup>R. C. Elton, in Ref. 58, pp. 131–142 and references therein.
- <sup>199</sup>B. N. Chichkov and E. E. Fill, *Phys. Rev. A* **42**, 599 (1990).
- <sup>200</sup>J. Nilsen, *J. Quant. Spectrosc. Radiat. Transf.* **47**, 171 (1991).
- <sup>201</sup>V. Yu. Politov, P. A. Loboda, V. A. Lykov, and J. Nilsen, *Opt. Commun.* **108**, 283 (1994).
- <sup>202</sup>P. Belerdorfer, S. R. Elliot, and J. Nilsen, *Phys. Rev. A* **49**, 3123 (1994).
- <sup>203</sup>S. J. Stephanakis *et al.*, *IEEE Trans. Plasma Sci.* **16**, 472 (1988).
- <sup>204</sup>C. Deeney, T. Nash, R. R. Prasad, and J. P. Apruzese, *Appl. Phys. Lett.* **58**, 1021 (1989).
- <sup>205</sup>J. L. Porter *et al.*, *Phys. Rev. Lett.* **68**, 796 (1992).
- <sup>206</sup>E. E. Fill, C. Bergmann, A. Lyras, and T. Schlegel, in Ref. 60, p. 147.
- <sup>207</sup>K. J. Ilcisin, F. Aumayr, J. L. Schwob, and S. Suckewer, *J. Opt. Soc. Am. B* **11**, 1436 (1994).
- <sup>208</sup>N. Qi, D. A. Hammer, D. H. Kalantar, and K. C. Mittal, *Phys. Rev. A* **47**, 2253 (1993).
- <sup>209</sup>A. V. Vinogradov and I. I. Sobel'man, *Sov. Phys. JETP* **36**, 1115 (1973).
- <sup>210</sup>L. P. Presnyakov and A. D. Ulantsev, *Sov. J. Quantum Electron.* **4**, 1320 (1975).
- <sup>211</sup>M. D. Scully, W. H. Louisell, and W. B. McKnight, *Opt. Commun.* **9**, 246 (1973).
- <sup>212</sup>P. L. Hagelstein, *Proc. SPIE* **3156**, 230 (1997).
- <sup>213</sup>W. Tighe *et al.*, *Rev. Sci. Instrum.* **59**, 2235 (1998).
- <sup>214</sup>T. S. Luk, A. McPherson, G. Gibson, K. Boyer, and C. K. Rodhes, *Opt. Lett.* **14**, 1113 (1989).
- <sup>215</sup>S. Watanabe, A. Endoh, M. Watanabe, and N. Sarukura, in *Short Wavelength Coherent Radiation: Generation and Applications*, edited by R. W. Falcone and J. Kirz (OSA, Washington, 1998).
- <sup>216</sup>J. Dunn, J. Nilsen, A. L. Osterheld, Y. Li, and V. N. Shlyaptsev, *Opt. Lett.* **24**, 101 (1999).
- <sup>217</sup>D. Strickland and G. Mourou, *Opt. Commun.* **56**, 219 (1985).
- <sup>218</sup>E. B. Treacy, *IEEE J. Quantum Electron.* **QE-5**, 454 (1969).
- <sup>219</sup>O. E. Martinez, *IEEE J. Quantum Electron.* **QE-23**, 1385 (1987), **QE-23**, 59 (1987).
- <sup>220</sup>D. E. Spence, P. N. Kean, and W. Sibbett, *Opt. Lett.* **16**, 42 (1991).
- <sup>221</sup>L. Spinelli, B. Couillard, N. Goldblat, and D. K. Negus, in *Conference on Lasers and Electro-Optics*, 1991, Vol. 10, paper CPDP7, OSA Tech. Digest Series (Optical Society of America, Washington D.C., 1991).
- <sup>222</sup>See Refs. 5–7, 65, 69, and 70 in Backus *et al.*, Ref. 62 and Ref. 7 in D. P. Umstadter *et al.*, Ref. 64.
- <sup>223</sup>J. P. Zhou, C. P. Hung, C. Shi, H. C. Kapteyn, and M. M. Murnane, *Opt. Lett.* **19**, 126 (1994); J. V. Rudd, G. Korn, S. Kane, J. Squire, and G. Mourou, *ibid.* **18**, 2044 (1993); B. E. Lemoff and C. P. J. Barty, *ibid.* **18**, 1651 (1993); W. E. White, F. G. Patterson, R. L. Combs, D. F. Price, and R. L. Shepherd, *ibid.* **18**, 1343 (1993).
- <sup>224</sup>H. Takuma *et al.*, in *X-ray Lasers 1998*, Proceedings of the 6th International Conference on X-Ray Lasers, edited by Y. Kato, H. Takuma and H. Daido (Institute of Physics, University of Berkshire, Reading, 1999).
- <sup>225</sup>P. V. Nickles, M. Schnürer, M. P. Kalashnikov, I. Will, W. Sander, and V. N. Shlyaptsev, *Proc. SPIE* **2520**, 373 (1995).
- <sup>226</sup>P. V. Nickles, V. N. Shlyaptsev, M. Schnürer, M. P. Kalashnikov, T. Schlegel, and W. Sandner, *Opt. Commun.* **142**, 257 (1997).
- <sup>227</sup>W. Hartmann, H. Bauer, J. Christiansen, K. Frank, H. Kuhn, M. Stetter, R. Trotz, and T. Wagner, *Appl. Phys. Lett.* **58**, 2619 (1991).
- <sup>228</sup>J. J. Rocca, D. C. Beetle, and M. C. Marconi, *Opt. Lett.* **13**, 565 (1988).
- <sup>229</sup>H. Conrads, *Z. Phys.* **444**, 200 (1967).
- <sup>230</sup>P. Bogen, H. Conrads, G. Gatti, and W. Kohlhaas, *J. Opt. Soc. Am.* **58**, 203 (1968).
- <sup>231</sup>R. A. McCorkle, *Appl. Phys. A: Solids Surf.* **26**, 261 (1981).
- <sup>232</sup>S. M. Zakharov, A. A. Kolomenskii, S. Pikuz, and A. I. Samokhin, *Sov. Tech. Phys. Lett.* **6**, 486 (1980).
- <sup>233</sup>M. C. Marconi and J. J. Rocca, *Appl. Phys. Lett.* **54**, 2180 (1989).
- <sup>234</sup>J. J. Rocca, M. C. Marconi, and F. G. Tomasel, *IEEE J. Quantum Electron.* **29**, 182 (1993).
- <sup>235</sup>F. G. Tomasel, J. J. Rocca, O. D. Cortázar, B. T. Szapiro, and R. W. Lee, *Phys. Rev. E* **47**, 3590 (1993).
- <sup>236</sup>C. A. Morgan, H. R. Griemond, and R. C. Elton, *Phys. Rev. E* **49**, 2282 (1994).
- <sup>237</sup>F. G. Tomasel, J. J. Rocca, and V. N. Shlyaptsev, *IEEE Trans. Plasma Sci.* **24**, 49 (1996).
- <sup>238</sup>T. Hosakai, M. Nakajima, T. Aoki, M. Ogawa, and K. Horioka, *Jpn. J. Appl. Phys., Part 1* **36**, 2327 (1997); H. Bender III, S. E. Grantham, V. N.

- Shlyaptsev, J. J. Rocca, M. C. Richardson, and W. T. Silfvast, in *X-ray Lasers 1998*, Proceedings 6th International Conference on X-Ray Lasers, edited by Y. Kato, H. Takuma and H. Daido (Institute of Physics, University of Berkshire, Reading, 1999).
- <sup>239</sup> J. J. Rocca, O. D. Cortázar, B. T. Szapiro, F. G. Tomasel, and D. Hartshorn, Proc. SPIE **2012**, 67 (1993); J. J. Rocca, F. G. Tomásel, C. A. Moreno, V. N. Shlyaptsev, M. C. Marconi, B. A. Benware, J. J. Gonzalez, J. L. A. Chilla, and C. D. Macchietto, J. Phys. (Paris), Colloq. **7**, C4-353 (1997).
- <sup>240</sup> V. N. Shlyaptsev, A. V. Gerusov, A. V. Vinogradov, J. J. Rocca, O. D. Cortázar, F. Tomasel, and B. Szapiro, Proc. SPIE **2012**, 99 (1993); V. N. Shlyaptsev, J. J. Rocca, P. V. Nickles, M. P. Kalashnikov, and A. L. Osterheld, in Ref. 2.
- <sup>241</sup> A. Bobrova, S. V. Bulanov, T. L. Razinkova, and P. V. Sasorov, Plasma Phys. Rep. **22**, 349 (1996); R. Nemirowsky, A. Ben-Kish, M. Shuker, and A. Ron, in *X-ray Lasers*, Proceedings 6th International Conference on X-ray Lasers, edited by Y. Kato, H. Takuma and H. Daido (Institute of Physics, University of Berkshire, Reading, 1999).
- <sup>242</sup> J. J. Gonzalez, M. Frati, J. J. Rocca, and V. N. Shlyaptsev, in *X-ray Lasers 1998*, Proceedings 6th International Conference on X-Ray Lasers edited by Y. Kato, H. Takuma, and H. Daido (Institute of Physics, University of Berkshire, Reading, 1999).
- <sup>243</sup> P. G. Burkhalter, G. Mehlman, F. C. Young, S. J. Stephanakis, V. E. Scherrer, and D. A. Newman, J. Phys. (Paris), Colloq. **47**, C-247 (1986) [see Ar spectra in Fig. 6].
- <sup>244</sup> A. Hildebrand, A. Ruhmann, S. Maurmann, and H. J. Kunze, Phys. Lett. A **221**, 335 (1996).
- <sup>245</sup> B. R. Benware, C. H. Moreno, D. J. Burd, and J. J. Rocca, Opt. Lett. **22**, 796 (1997).
- <sup>246</sup> C. H. Moreno, M. C. Marconi, V. N. Shlyaptsev, and J. J. Rocca, IEEE Trans. Plasma Sci. **27**, 6 (1999).
- <sup>247</sup> M. C. Marconi, J. L. A. Chilla, C. H. Moreno, B. R. Benware, and J. J. Rocca, Phys. Rev. Lett. **79**, 2799 (1997).
- <sup>248</sup> R. A. London, M. Strauss, and M. D. Rosen, Phys. Rev. Lett. **65**, 563 (1990).
- <sup>249</sup> M. D. Feit and J. J. A. Flech, J. Opt. Soc. Am. B **7**, 2048 (1990).
- <sup>250</sup> B. Rus, thèse de L'Université Paris VII. Orsay, Jan., 1995, Proc. SPIE **3156**, 17 (1997); F. Albert *et al.*, *ibid.* **3156**, 247 (1997)997.
- <sup>251</sup> F. C. Young, S. J. Stephanakis, V. E. Scherrer, B. L. Welch, G. Melimav, P. G. Burkhalter, and J. P. Apruzese, Appl. Phys. Lett. **50**, 1053 (1987).
- <sup>252</sup> S. K. Kikhlevsky, L. Kozma, L. Palladino, A. Reale, F. Flora, and G. Giordano, Proc. SPIE **3156**, 1 (1999).
- <sup>253</sup> M. Shuker, A. Ben-Kish, R. A. Nemirowsky, and A. Ron, in *X-ray Lasers*, Proceedings 6th International Conference on X-Ray Lasers, edited by Y. Kato, H. Takuma, and H. Daido (Institute of Physics, University of Berkshire, Reading, 1999).
- <sup>254</sup> M. Pöckl, R. Fertner, M. Hebenstreit, T. Neger, and F. Aumayr, Proc. SPIE **2520**, 379 (1995); M. Hebenstreit, R. Fertner, T. Neger, M. Pöckl, and F. Aumayr, J. Phys. D **29**, 1933 (1996).
- <sup>255</sup> H. J. Kunze, K. N. Koshelev, C. Steden, D. Uskov, and H. T. Wieschebrink, Phys. Lett. A **194**, 183 (1994).
- <sup>256</sup> P. B. Corkum and N. H. Burnett, *Short-Wavelength Coherent Radiation: Generation and Applications*, edited by R. Falcone and J. Kirz, OSA Proceedings Series, Vol. 2 (OSA, Washington, D.C., 1988).
- <sup>257</sup> B. E. Lemoff, C. P. J. Barty, and S. E. Harris, Opt. Lett. **19**, 569 (1994).
- <sup>258</sup> S. M. Hooker, P. T. Epp, and G. Y. Yin, J. Opt. Soc. Am. B **14**, 2735 (1997).
- <sup>259</sup> S. M. Hooker and S. E. Harris, Opt. Lett. **20**, 1994 (1995).
- <sup>260</sup> A. Goltsov, D. Korobkin, A. Morozov, and S. Suckewer, Proceedings 1998 International Congress on Plasma Physics and 25th EPS Conference on Controlled Fusion and Plasma Physics, Prague, 1998.
- <sup>261</sup> Y. Nagata, K. Midorikawa, S. Kubodera, M. Obara, H. Tashiro, K. Toyoda, and Y. Kato, Phys. Rev. A **51**, 1415 (1995).
- <sup>262</sup> B. N. Chichkov, A. Egbert, H. Eichmann, C. Momma, S. Nolte, and B. Wellegehausen, Phys. Rev. A **52**, 1629 (1995).
- <sup>263</sup> M. P. Kalachnikov *et al.*, Phys. Rev. A **57**, 4778 (1998); P. V. Nickles *et al.*, Proc. SPIE **3156**, 80 (1997).
- <sup>264</sup> D. Kim, C. H. Skinner, G. Umesh, and S. Suckewer, Opt. Lett. **14**, 665 (1989).
- <sup>265</sup> D. Kim, C. H. Skinner, and S. Suckewer, Proc. SPIE **1551**, 295 (1991).
- <sup>266</sup> L. Polonsky, C. O. Park, K. Krushelnick, and S. Suckewer, Proc. SPIE **2012**, 75 (1993).
- <sup>267</sup> A. Morozov, L. Polonsky, and S. Suckewer, Proc. SPIE **2520**, 180 (1995).
- <sup>268</sup> T. Hara, K. Ando, Y. Aoyagi, N. Kusakabe, and H. Yashiro, Jpn. J. Appl. Phys., Part 2 **28**, L1010 (1989).
- <sup>269</sup> N. Yamaguchi, T. Hara, C. Fujikawa, and Y. Hisada, Jpn. J. Appl. Phys., Part 2 **36**, L1297 (1997).
- <sup>270</sup> S. Basu, P. L. Hagelstein, and J. G. Goodberlet, Appl. Phys. B: Photophys. Laser Chem. **57**, 303 (1993).
- <sup>271</sup> P. Hagelstein, M. Muendel, J. Goodberlet, S. Basu, and S. Kaushik, Proc. SPIE **1551**, 88 (1991).
- <sup>272</sup> A. R. Prag, F. Loewenthal, and J. E. Balmer, Phys. Rev. A **54**, 4585 (1996).
- <sup>273</sup> P. Hagelstein (private communication).
- <sup>274</sup> J. J. Rocca, C. H. Moreno, M. C. Marconi, and K. Kanizay, Opt. Lett. **24**, 420 (1999); J. J. Rocca *et al.* in *X-ray Lasers*, edited by Y. Kato, H. Takuma, and H. Daido (Institute of Physics, University of Berkshire, Reading, 1999).