

Review

Technology Development of Electric Vehicles: A Review

Xiaoli Sun ¹, Zhengguo Li ^{1,*}, Xiaolin Wang ² and Chengjiang Li ²

¹ School of Automobile and Transportation, Shenzhen Polytechnic, Shenzhen 518055, China; sunxiaoli@szpt.edu.cn

² School of Engineering, College of Science and Engineering, University of Tasmania, Hobart TAS 7005, Australia; Xiaolin.wang@utas.edu.au (X.W.); Chengjiang.li@utas.edu.au (C.L.)

* Correspondence: lizhengguo@szpt.edu.cn; Tel.: +86-0755-2673-1099

Received: 12 November 2019; Accepted: 18 December 2019; Published: 23 December 2019



Abstract: To reduce the dependence on oil and environmental pollution, the development of electric vehicles has been accelerated in many countries. The implementation of EVs, especially battery electric vehicles, is considered a solution to the energy crisis and environmental issues. This paper provides a comprehensive review of the technical development of EVs and emerging technologies for their future application. Key technologies regarding batteries, charging technology, electric motors and control, and charging infrastructure of EVs are summarized. This paper also highlights the technical challenges and emerging technologies for the improvement of efficiency, reliability, and safety of EVs in the coming stages as another contribution.

Keywords: battery electric vehicles; batteries; charging technology; electrical motor and control; charging infrastructure

1. Introduction

The increasing number of internal-combustion vehicles which consume unrenewable conventional fuels has caused both energy and environmental issues [1]. Therefore, many countries have implemented new energy vehicles (NEVs) as alternatives to conventional vehicles to reduce the dependence on oil and air pollution caused by conventional vehicles [2–4]. As the world’s largest automotive market, China has been committed to promoting NEVs to reduce the consumption and import of oil [3,5,6]. In Europe, Germany proposes to have one million EVs in operation by 2020 to reduce CO₂ emissions [7–9]; France and UK have also aimed to restrict the in-country sale of conventional vehicles by 2040 [2]. To stimulate the adoption of NEVs, many countries offered subsidies and special tax policies, such as plug-in vehicle subsidies in the UK, the clean vehicle rebate project in the US, and the green vehicle purchasing promotion measures in Japan and China [10]. NEVs that use unconventional energy to power vehicles mainly include electric vehicles (EVs), hydrogen vehicles, natural gas vehicles, methanol and ethanol vehicles. Among these NEVs, EVs are considered as the most effective to achieve environmental and socioeconomic benefits [11].

As an emerging technology introduced after the industrial revolution, EVs have already existing for over 100 years. The first practical electrical car was created by Thomas Parker in 1884 [12]. Another famous example of early electric cars was Ferdinand Porsche’s electric car, which was manufactured in Germany in 1899 [12,13]. Compared with the steam and gasoline engines at that time, electric vehicles were quiet, easy to drive, and did not emit a strong-smelling pollutant [14]. Before Henry Ford developed the Model T with a new mass production process, EV makers experienced a degree of success in the 1920s, when 28% of total vehicles produced in the U.S. were electric. However, the promotion of EVs slowed due to the high price of electric cars and the rapid development

of conventional vehicles. From the beginning of the 21st century, research on EVs has been accelerated due to environmental pollution and energy-related issues [15]. With the engagement of government and industry, infrastructure and EVs technology have been improved. Global sales of EVs reached one-million in 2016 [16], and the sales of global light-duty EVs and plug-in hybrid electric vehicles exceeded five million in 2018 [17,18]. Famous auto-makers such as Volkswagen, Mercedes, and Ford, have addressed their ambitions of promoting EVs.

EVs mainly include pure electric vehicles (PEVs), hybrid electric vehicles (HEVs), and fuel cell electric vehicles (FCEVs) [16]. A pure electric vehicle, also called a battery electric vehicle (BEV), is entirely powered by a traction battery [19]. Figure 1 shows the simple design of a BEV. An HEV has two power sources and it combines an internal combustion engine system with an electric propulsion system. The existence of an electric power system is intended to achieve better fuel economy or better performance than that of conventional vehicles [20]. An FCEV refers to an EV that uses a fuel cell, instead of batteries, or in combination with a battery or supercapacitor to power an electric motor [21]. Although technically mature HEVs account for the largest proportion in the EVs market, they are not completely free from fuel oil. In addition, the market share of FCEVs is still tiny [21]. At the end of 2018, the global FCEV stock reached 11,200 [22]. The adoption of FCEVs is mainly suffering from the high cost of vehicles and infrastructure distribution. By comparison, BEVs are the optimal choice for addressing the environmental problems and the energy crisis because they have zero emissions and do not consume oil [23]. Therefore, this paper focuses on the technological development of EVs, which are a relatively mature technology that does not compromise the economic benefits.

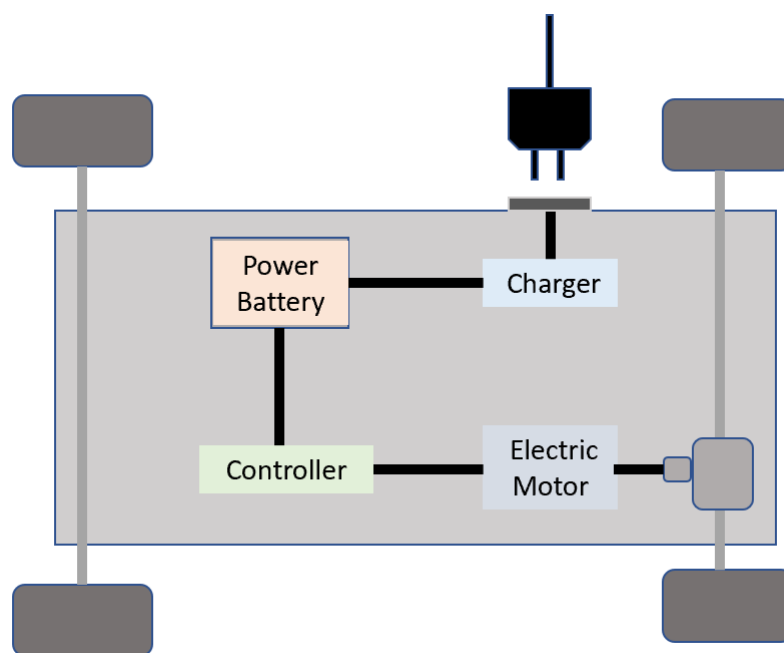

Figure 1. Simple design of a BEV.

Previous studies have reviewed EV technology from different perspectives. Andwari et al. [24] reviewed the technology and readiness levels of BEVs. They reported the technological readiness of different components of BEVs in the paper, however, the technological development challenges of BEVs' components were not a focus. Un-Noor et al. [25] studied key EV components, technologies, and challenges comprehensively. Their study mentioned all types of EVs. They collected a large amount of useful data about EVs but did not analyze the difficulties in the technological development of EVs from the data. Coffman et al. [26] summarized the factors which affected the adoption of EVs by the public. Liao et al. [27] have categorized influential factors for consumer preferences of EVs. Yong et al. [28] reviewed the latest development in EV technology, focused on charging management

strategies and smart grids, the impacts of EV rollout, and opportunities following EV deployment. Cuma et al. [29] presented a comprehensive review of various strategies of estimation for hybrid and battery EVs. In the paper of Groger et al. [30] an analysis of technological barriers for batteries in EV was provided. Although these studies have provided comprehensive analyses of EVs development, the technology of EVs is developing rapidly. In the literature of recent years, we were unable to find a review on the technological development of EVs that not only focused on technological difficulties of the key components, but also considered the possible direction of future development to overcome those the barriers. This paper reviews the development of key technologies for EVs, which assists in quickly understanding the state-of-art developments and provides the likely directions of technological development in the future.

The rest of this paper is structured as follows: In Sections 2–5, the detailed analyses and reviews of key technologies for EVs are provided. In Section 6, the challenges and emerging technologies related to EVs, which will be important for their future employment, are summarized.

2. Battery Technology of EVs

The technology development of the traction batteries has a great impact on EV industry, since the traction batteries are used to power the propulsion system of EV [31]. Once a rechargeable lead-acid battery appeared, it was applied to an EV. With the development of battery technology, an increasing number of different types of power batteries have appeared in the battery market [32]. Despite the new technology of the battery, the requirements for the traction battery have not significantly changed [33]. Differently from starting, lighting, and ignition batteries, EV batteries need to provide continuous power. Thus, a higher energy capacity is highly important. Moreover, high specific power, high specific energy, and high energy density are crucial [31–34]. At present, the types of rechargeable batteries that are used in EVs mainly includes lead-acid batteries, nickel-metal hydride (Ni-MH) batteries, lithium-ion batteries [35].

2.1. Lead-Acid Batteries

The lead-acid battery is rechargeable and was designed by French physicist Gaston Plante in 1860 [36]. It has a negative plate made from lead metal and a positive plate from brown lead dioxide, which are both immersed in an electrolyte composed of diluted sulfur acid. Electrical energy is stored in a lead-acid battery and can be converted from chemical energy into electrical energy. The lead-acid battery has the following reversible reactions [37,38]:

Positive electrode reaction:



Negative electrode reaction:

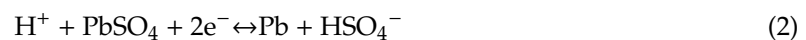

Net reaction:

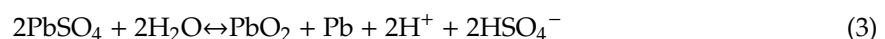

The lead-acid battery is the earliest and still most widely used type of rechargeable battery. Flooded lead-acid batteries are the cheapest batteries available and, in the past, were also the most common power source. Flooded lead-acid batteries can be categorized into two types: engine starter batteries and deep cycle batteries. An engine starter battery provides a short but high surge current when an engine starter works and is charged by the automobile's alternator. Deep cycle batteries are designed to be regularly deeply discharged and used for EVs such as forklifts or golf carts. The valve regulated lead-acid battery is another kind of lead-acid battery, in which lead-acid is closed with a

pressure regulatory valve. It is also called a maintenance-free battery because it does not require regular checking of the electrolyte level [38].

Some EVs chose lead-acid batteries due to their high reliability, high availability and low cost. Previously, the biggest problem with lead-acid batteries was the environmental impact through their manufacture, use, disposal, or recycling. Lead has a seriously harmful effect on human health. However, in the EU and USA, the collection and recovery rate of lead-based batteries has now reached more than 99%. This is a rather high level compared with other products. In most developed countries, 95%–99% of used batteries are recycled [39]. However, lead-acid batteries are not applied on a large scale in EVs due to their lower specific energy and lower energy density. Compared with Lithium-ion batteries, the same mass or volume of lead-acid batteries stores less energy, as shown in Figure 2. The mass and volume of batteries are important for EVs. With a smaller or lighter battery, an EV can travel farther before recharging. Currently, lead-acid batteries are mainly used in low-speed EVs.

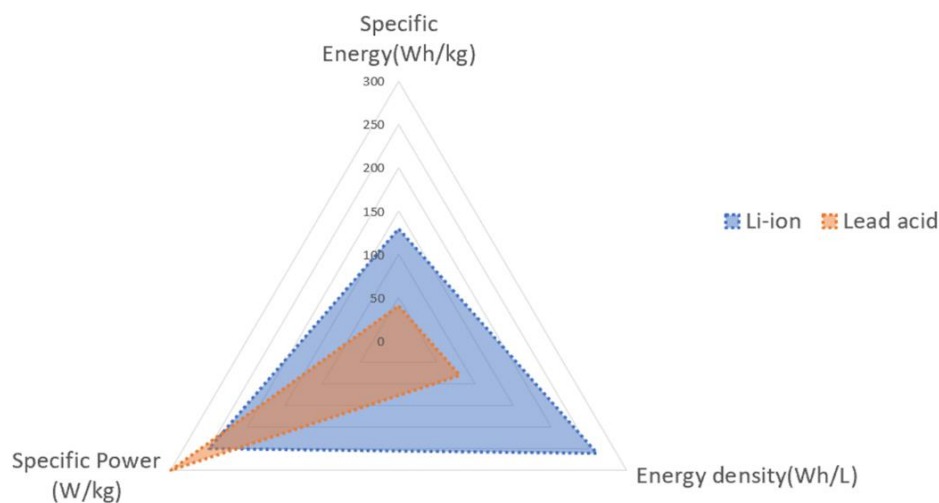
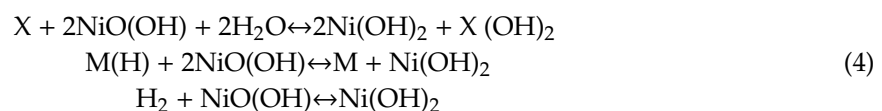

Figure 2. Comparison of lithium-ion and lead-acid batteries.

2.2. Nickel-Metal Hydride Batteries

Nickel-metal hydride batteries are composed of nickel hydroxide as a positive electrode, different materials as a negative electrode, and a potassium hydroxide solution as the electrolyte. Due to different negative electrode materials, nickel batteries include nickel-iron (Ni-Fe) batteries, nickel-cadmium (Ni-Cd) batteries, nickel-zinc (Ni-Zn) batteries, Ni-MH batteries, and nickel-hydrogen (Ni-H₂) batteries [36,40–44]. Among these, Ni-MH batteries have been the choice for EVs since the 1990s [45,46]. Equation (4) indicates the overall electrochemical reaction that occurs in the Ni-MH battery [44]:



In comparison with lead-acid batteries, a Ni-MH battery has up to double the specific energy and a greater energy density, as shown in Figure 3. However, Ni-MH batteries do have disadvantages, such as having lower charging efficiencies than other batteries, and a higher self-discharge that is exacerbated in a high-temperature environment. The application of Ni-MH batteries in EVs has become stagnant in recent years because of the patent encumbrance of Ni-MH batteries for heavy-duty vehicles [47]. The patent encumbrance of Ni-MH batteries for heavy-duty vehicles refers to the obstacles of commercialization of Ni-MH battery technology arising from the patent system that is designed to protect business benefits. The reasons for the obstacle may relate to the potential importance of Ni-MH battery technology for EVs. Others think that it is the result of the inability of the technology to compete with other batteries, such as lithium batteries [46].

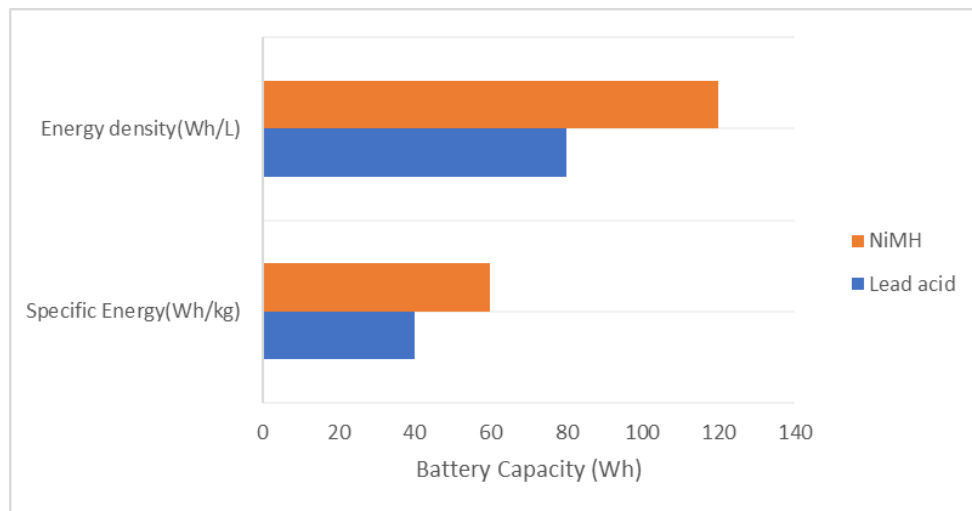

Figure 3. Comparison of Ni-MH and lead-acid batteries.

2.3. Lithium-ion Batteries

Lithium-ion batteries captured the market for energy storage and movable electric products after being first commercially produced by Sony Company in 1991. They simultaneously have a large power storage capacity, small size and are lightweight [48]. Compared with other batteries shown in Figure 4, the lithium-ion battery has significant advantages in terms of specific energy and energy density.

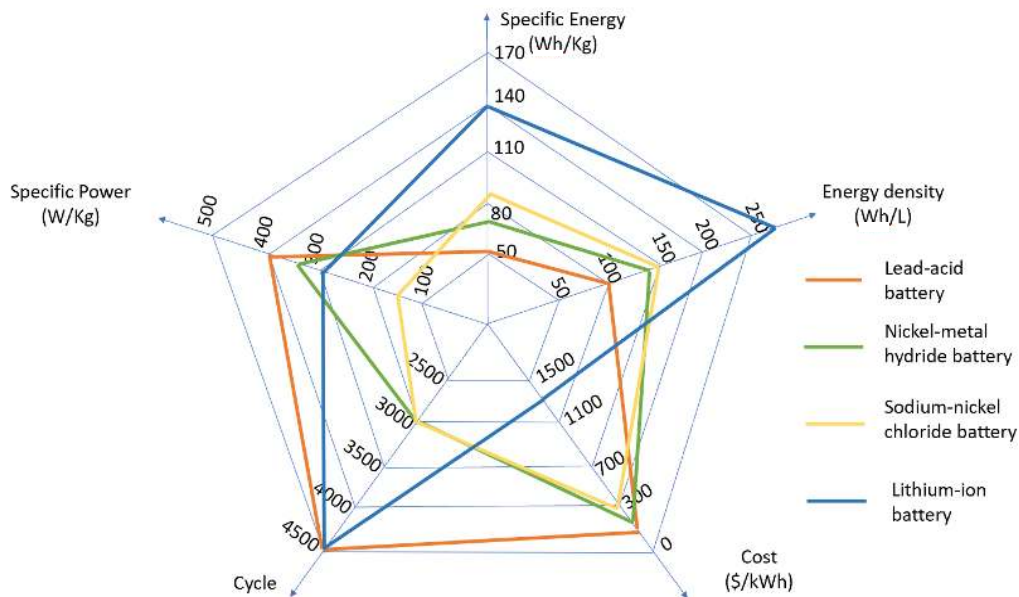

Figure 4. Comparison of the characteristics of various power batteries.

Additionally, since lithium-ion batteries have high energy efficiency, an unnoticeable memory effect, long cycle life, and high-power density, they are presently the most competitive choice of energy storage device for EVs [49,50]. Therefore, lithium-ion batteries dominate the major market for commercialized automotive batteries currently. BMW i3, Tesla, Nissan Leaf, BYD and other EVs all use lithium-ion batteries as driving power. According to the different materials used in positive electrode, lithium-ion batteries include lithium cobalt oxide (LiCoO₂) batteries, lithium manganese oxide (LiMn₂O₄) batteries, lithium iron phosphate (LiFePO₄) batteries, lithium nickel-manganese-cobalt oxide (LiNiMnCoO₂ or NMC) batteries, lithium nickel-aluminum-cobalt oxide (LiNiCoAlO₂ or NCA) batteries and lithium titanate (Li₄Ti₅O₁₂) batteries [40,42,51]. Compared with other lithium-ion

batteries, the LiFePO_4 batteries are considered to have high discharge current, and low cost [44]. Furthermore, they have good thermal and chemical stability and are widely applied in EVs [44]. The other batteries which have been successfully adopted by car manufactures are NMC and NCA [49]. NMC is a leading contender for automotive applications. NCA technology has been used in Tesla and is expected to be more dominating [49]. However, as lithium-ion batteries suffer from the barriers of charging rates, lifespan, and reliability, they need to be improved further [40,45,49–53]. The latest research shows that adding graphene to the cathode materials of lithium-ion batteries can improve their performance [54,55]. On account of widespread prospects for new-generation EV applications, lithium-ion battery technology has attracted significant attention of numerous researchers.

2.4. Other Batteries

In addition to the batteries mentioned above, different types of energy storage systems (ESSs) such as sodium nickel chloride batteries, metal–air batteries, sodium-beta batteries, fuel cells (FCs), and ultracapacitors are also used in EV applications. Sodium nickel chloride batteries are also called Zebra batteries. The name “Zebra” derived from the “Zero Emission Battery Research Activity” (ZEBRA) project. A Zebra battery has a molten salt electrolyte that can maintain in a liquid state only at a high temperature of 300–350 °C [36,40,42]. It has advantages including high energy density, low corrosion, high safety, insensitivity to over-charging and over-discharging, a long life-cycle, and the lowest price of the EV batteries. The drawbacks of this battery are the low specific power, a self-discharge problem, and the need for temperature management. In addition to use in specific areas, such as submarines, military applications, and telecommunication facilities [40,44,56,57] Zebra batteries have been used in many power storage applications. Metal-air batteries contain a positive electrode made of metal, with oxygen in the air acting as the negative electrode. The anode metal can be lithium (Li), calcium (Ca), magnesium (Mg), iron (Fe), aluminum (Al), or zinc (Zn). Among the metal–air batteries, lithium–air (Li–air) batteries are considered as most promising for EV applications due to the high specific energy [44]. Sodium-beta batteries use solid-state electrolyte and are categorized into sodium–sulfur (Na–S) and sodium metal halide. A Na–S battery was first applied to powering an EV in the 1960s by Ford. Although Na–S batteries have high power, energy density, and energy efficiency, obstacles such as high operating temperature, high internal resistance, and Na corrosion, may occur in the application of Na–S batteries in EVs. Different from other ESSs, FCs are typical electrochemical systems, which convert chemical energy into electricity through chemical reactions in FCs. FCs consist of fuel in a liquid or gaseous state as anode and oxidant, with oxygen from the air often used as a cathode. The external supplement of fuel and oxidant makes FCs generate electricity continuously. FCs use hydrogen, methanol, fossil fuels, or natural gas as a fuel depending on the fuel and oxidant reactions, electrolyte type, working temperature, and applications. Hydrogen FCs (HFCs) use hydrogen as fuel and have become popular and accessible in EV applications in recent years. Ultracapacitors (UCs) have a similar structure and function with a normal capacitor. However, a UC can have high special power in the range of 1000–2000 W/kg with 95% energy efficiency. Due to fast charging and discharging characteristics, UCs function as energy stores in electric braking and rapid acceleration of EVs. Lately, lithium-ion capacitors have emerged and lithium-ion capacitors with 80 Wh/kg energy density are considered as substitutes for lithium-ion batteries in the market for EV applications [36,40,58,59].

The performance of batteries for EVs power depends on some essential characteristics, such as energy density, power density, and energy efficiency. The advantages and disadvantages of the most commonly used batteries have been compared as shown in Table 1 [24,25,28,31,39,40,43,49,51]. Yet, other features, such as limiting self-discharge, small size, long lifespan, and low maintenance are considered in batteries for EV applications. For driving power source, a good performance also includes matching the power requirement of EV energy consumption, which is frequently changeable throughout the battery discharging process. The concept of hybrid energy storage systems was thus proposed; that is, not only one battery or one kind of ESSs would be used as an energy resource to power EVs. Therefore, the materials, energy management, size, cost and safety measures of batteries have been continuously developed [59–61].

Table 1. Comparison of the most commonly used batteries.

Cathode Material	Specific Energy (Wh/kg)	Cycle	Optimal Working Temp (°C)	Efficiency (%)	Advantages	Disadvantages
Lead acid	30–50	2000–4500	−20–60	70–90	Low cost, mature technology, high specific power	Low specific energy, short service life, high maintenance requirements
Ni-Fe	30–55	1200–4000	−10–45	75	Good scope for traction applications	Low specific energy, power and energy density; high self-discharge, hydrogen evolution, high purchase and maintenance cost
Ni-Zn	60–65	100–300	−10–50	76	High specific energy	High cost, short service life
Ni-Cd	40–50	2000–3000	−40–60	60–90	High specific energy	High cost cadmium toxicity, recycling issues
Ni-MH	50–70	500–3000	−40–50	50–80	High specific energy, safety, long service life	High cost, high self-discharge, memory effect
Ni-H ₂	60–70	6000–40000	−20–60	80–90	Extreme long-life cycle and tolerance to overcharge or over-discharge without damage	Expensive, low volumetric energy density, self-discharge proportional to H ₂ pressure
LiCoO ₂	150–190	500–1000	150	80–90	In common use, high power density, high energy density	Low self-discharge, low safety, high cost
LiMn ₂ O ₄	100–135	500–1000	250	85	High power density, very good thermal stability	Moderate cycle life, lower energy
LiFePO ₄	90–120	1000–2000	270	90	Very good thermal stability and cycle life, good power capability no memory effect, lighter and smaller	Low energy density
LiNiMnCoO ₂	140–180	1000–2000	210	90–95	High power density, high energy density, high energy efficiency, good cycle life	Structural/chemical instabilities during repeated cycling

3. Charging Technology

In addition to the capacity of batteries, charging is another challenge for BEVs. Charging technology and battery technology are supplementary to each other. To release the “range anxiety” of EV drivers, charging technology is crucial and plays an important role in the BEV industry. With the rapid development of charging technology and the spread of charging infrastructure, charging is becoming more convenient and faster.

Under different energy transfer modes, battery charging for EVs can be classified into conductive charging, inductive charging, and battery swapping [62]. According to the charging methods EVs need different charging infrastructures and equipment.

3.1. Conductive Charging

The conductive charging scheme allows the physical connection of charger and vehicle [62]. An unmediated contact occurs in power transferring from power supply to battery. It consists of alternating current (AC)/direct current (DC) and DC/DC converters with some power factor correction (PFC) and can be classified as an on-board or off-board charger [63]. The charger is the connection of energy transmission. The charging process is the process of transferring the electricity from the power grid to the EV battery. Since EV batteries can only be charged with DC, a charger is required for converting AC from the power grid into DC. Figure 5 shows the basic layout of an on-board battery charger.

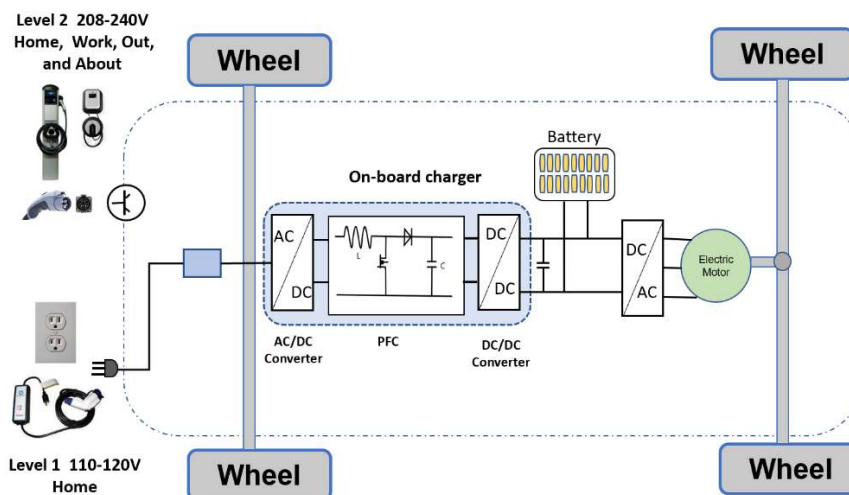

Figure 5. The basic layout of an on-board battery charger.

3.1.1. Battery Charger

According to the direction of power flow, charger systems can be classified into off-board or on-board chargers with one-way or two-way power flow. One-way power flow chargers decrease hardware demands and makes interconnection simpler. Two-way power flow chargers allow the energy flow in both directions [64]. An on-board charger is applied mainly to slow charging, and the charging activity is carried out inside the EV [62]. The benefit of on-board chargers for EVs is their significantly reduced requirements of external infrastructure for charging a vehicle. The drawbacks of on-board chargers are mainly increased weight, volume, and cost of EVs [63,64]. Light weight, small size, high efficiency, and simple control are the desired features for on-board chargers [65]. Whitaker et al. [66] introduced an isolated on-board charger that employs silicon carbide power devices to realize high density and high efficiency for BEV application. A new electrolytic two-way on-board charger without capacitor was proposed in the paper of Shin et al. [67]. With a very simple control algorithm, harmonic regulation and charging/discharging control can be achieved in the absence of a high-performance controller. Tera et al. [68] proposed a core with curved edges for reducing the loss of

the laminated core inductor to increase the efficiency and reduce the size of the on-board charger. Mithat et al. [69] presented the design and implementation of a two-way on-board charger that can provide reactive power support to the power grid in addition to charging the vehicle battery.

Off-board chargers are used for DC fast charging at level-3 and could be connected to an urban area and a high way refueling station. These usually work with a 480 V or higher voltage and an AC circuit, and an off-board charger is required to provide regulated AC-DC adaption [62]. Bojrup et al. [70] presented a high power off-board charger, which joints fast charging with active filtering. The paper of Ota et al. [71] proposed an off-board charger that achieves seamless charge and discharge control by the DC connector of the BEV.

3.1.2. Charging Techniques of Conductive Charging

The contact at higher voltage potential difference is restricted by the unmediated connection of charger and vehicle [72]. Various charging techniques can be used with conductive charging. Constant current (CC), constant voltage (CV), constant power (CP), taper charging and trickle charging are the conventional charging techniques. An advanced technique, which involves a combination of the above techniques, such as CC/CV, is utilized to charge batteries rapidly. In addition, pulse-charging and negative pulse-charging are also used for fast charging [62,73].

CC-charging means charging the EV battery with constant current flow and changeable voltage. Nickel-cadmium and nickel-metal hydride batteries usually use this kind of charging [62]. CV-charging employ constant voltage and variable current to charge the battery, until the charging current declines to almost zero. CP is a charging method with constant charging power [73]. In trickle charging, the battery self-discharge is compensated by a small current. Taper charging uses unregulated CV charging, which may result in serious damage to the cells through overcharging [62,73].

In general, the CC-CV charging technique is the optimal choice for fast charging of lithium-ion batteries, in which operating can be categorized into two major processes. First, a CC is employed to charge a battery until a predefined voltage value is reached, and then CV is used until current drops to almost zero. The benefits of CC-CV charging are the prevention of the over-voltages and reduced thermal stress.

Pulse-charging means feeding charge current in pulses. Some studies have considered pulse-charging as a rapid battery charge technique. For this method, precise pulse control is important. To keep up with the charging process, some chemical reactions would take place during the rest period between two charging pulses and the gas formation at the electrode surface would be decreased at the same time. Negative pulse-charging is a supplementary method with pulse-charging. A very short discharge pulse is employed during the rest period of charging to remove gas bubbles built up on the electrode [62,73].

3.2. Inductive Charging

Inductive charging, also known as wireless charging, as a more flexible and easier charging method that has attracted broad attention. Instead of a direct cable connection, the wireless link effectively eliminates sparking, which may be caused by plugging and unplugging, and reduces the limits of EV applications in a certain situation, such as near gas stations and in airports. Furthermore, inductive charging could make charging while driving, also called dynamic charging, possible.

The idea of wireless power transfer (WPT) first occurred in the late 19th century. WPT can be classified into two major technologies: inductive power transfer (IPT) and capacitive power transfer (CPT). Conventional CPT can only be used for low output power with tiny air gaps of between 10^{-4} and 10^{-3} m, while IPT can be applied for large air gaps, up to several meters, for high power applications reaching beyond 10 kW.

Wireless charging for EVs can be classified as stationary, semi/quasi-dynamic, and dynamic charging systems. Stationary systems function like current plug-in chargers but supply some unique benefits such as “park and charge”. Instead of the conductive charging system, there is an onboard

receiving coil and an outside transmitting coil on the road surface. Quasi-dynamic systems provide a short charging time in a dynamic environment and charging can take place at a bus stop, taxi stop, and traffic lights. Dynamic wireless power transfer (DWPT) systems can charge when vehicles are moving. Hence, DWPT can overcome range anxiety by providing charging to a battery and increasing the drive distance [74]. It has been reported that the demand for battery capacity can be cut by 80%, which reduces the initial cost of a new EV [75].

WPT, as a compelling technology for EVs, has been studied within a wide range of topics by many leading research institutes, such as the Korean Institute of Advanced Technology (KAIST, Daejeon, Korea), Oak Ridge National Laboratory (ORNL, Oak Ridge, TN, USA), and the University of Auckland (UoA, Auckland, New Zealand). KAIST focusses on DWPT and has designed multiple systems for EVs from “1st generation” with an E-type supply track instead of numerous charging pads, to “6th generation” with a W-type power supply track without a core plate in the track [76,77]. The research conducted by ORNL concentrates on using multiple-segmented coils to transmit energy to moving vehicles instead of applying a long supply track [78]. With study of coil and pad planning, vehicle integration, current control, and the interplay between the grid and charging system [79–83], ORNL designed a stable charging system, which was applied in a Toyota Prius [84]. In 2010, a flux pipe was introduced by UoA, whose advantage is providing the system with increased tolerance against lateral offset between receiving and transmitting coils and a concentrated magnetic flux in the air gap [85]. This research was conducted partly at the UoA. In addition to the above research, the topics of WPT study also involve key components of a WPT system, including power converter, compensation topology, and coils, as well as important auxiliary features, such as foreign object detection and communication, high temperature superconductors (HTS) as an emerging coil material, standards of BEV WPT, impact of WPT on the power grid, and the cost of WPT. Furthermore, the latest research work focusses on the health and safety concerns of WPT systems [86].

3.3. Battery Swapping

Battery swapping is undoubtedly one of the most time-saving and easy charging methods. At a battery swapping station (BSS), EV owners can simply swap their depleted battery for a fresh one. A BSS mainly has a distribution transformer, AC/DC converters, battery chargers, robotic arms, charging racks, maintenance systems, control systems, and other equipment involved in the swapping and charging of the batteries [87–89]. From a power grid perspective, the BSS has a large variable demand. As an assembly of batteries, BSS could also be used to provide services to the grid, which can inject power back into the power system to balance the load demands of the grid. From the view of EV owners, a BSS provides a payable service to supply a fully charged battery. This service can be considered as a similar service that gasoline stations provide for internal combustion vehicles [90]. Research about battery swapping not only involves the fields relevant to the BSS used for battery swapping, but also those in the provision of energy and auxiliary services by the BSS to the power grid. Yan et al. [91] presented real-time energy management for a BSS is involved in a smart community microgrid and uses variable renewable energy to supply EV batteries and conventional residential loads. The paper of Mahoor et al. [92] focused on designing a mathematical model for BSS operation that can both satisfy the customer demand of fully charged batteries and compensate operation cost through energy sellback. Furthermore, topics related to the optimal distribution and sizes of BSS have also been investigated in battery swapping studies. Sultana et al. [93] used a novel Grasshopper optimizer algorithm to help a BSS reduce energy loss and increase voltage stability. However, obstacles to BSS development remain, such as standardization of EV battery packs, consumer recognition of the BSS model, and reliable estimation of battery health status.

3.4. EV Charging Standards

Different countries have their own standards for EV charging. The most popular standards in the world are the Society of Automotive Engineers (SAE, Warrendale, PA, USA) standards, International

Electrotechnical Commission (IEC, Geneva, Switzerland) standards, Japan Electric Vehicle Association Standards (JEVS), and Chinese National Standard (GB) ones. These standards are published by the countries whose EV numbers are among the highest globally at present, such as America, the European Union, Japan, and China. Table 2 shows the main charging standards that are widely implemented in those countries.

Table 2. Charging standards based on SAE, ICE, GB, and JEVS.

Code	Refer to
SAE	
J-1773	SAE Electric Vehicle Conductive charge coupler
J-2954	SAE Electric Vehicle Inductively-coupler charging Wireless power transfer for light-duty plug-in Electric vehicles and alignment methodology
ICE	
62196-X	Plug, Socket-Outlets, Vehicle Couplers and Vehicle inlets–Conductive charging of electric vehicles
61851-X	Electric vehicles conductive charging system
62840-X	Electric vehicle battery swap system
62983	Electric charge station
61980-1:2015	Electric vehicle wireless power transfer systems
GB	
GB/T 18487.X-2015	Electri J-1772c vehicles conductive charging system
GB/T 20234.X-2015	Electric vehicles conduction charging connecting device
GB/T 27930-2015	Communication protocol between the off-board charger and battery management system
QC/T 895-2011	Electric vehicles onboard charger
QC/T 841-2010	Electric vehicles conductive charging interface
JEVS	
C601: 2000	Plugs and receptacles for EV charging
G105: 1993	Connectors applicable to quick charging system at Eco-Station for EVs
G106: 2000	EV Inductive charging system: General requirements
G107: 2000	Inductive charging system: Manual connection
G108: 2001	EV Inductive charging system: Software interface
G109: 2001	EV Inductive charging system: General requirements

Note: X in the Table symbolizes that exists multiple standards in that series and are denoted by series number.

The SAE J1772 standard also covers the conductive charging requirement to promote charging in North America. According to the US SAE standard, AC charging is categorized into AC Level 1 and AC Level 2, with different charging voltages and powers. Both need to be done using an on-board charger. In the mode of AC Level 1, 120 V single-phase AC is used for slow charging and the charging current is 12–16 A [94]. This mode is suitable for most EV owners to charge at home during the night. The charging time of this mode is relatively long, taking almost 17 h for the battery to charge from state of charge (SOC) 20% to full charge. However, electricity can be directly drawn from the lighting circuit without any additional equipment in this mode, which is convenient and simple. The cost of installing AC Level 1 equipment is only \$500–800. In addition, charging at night uses the grid's low consumption time and incurs a discounted electricity price, which reduces the use cost of the EV. In the mode of AC Level 2, the charging voltage can reach up to 240 V, charging current attains 80 A, and charging power attains 19.2 kW, which results in a significant reduction of charging time: it takes 1.2–7 h to charge from SOC 20% to full charge depending on the power of the charger. A special charging device is required to be installed in this mode, which usually is used in public and dedicated private facilities. Despite the high installation cost of an AC Level 2 charging device, which may reach \$1000–3000 [94], most EV owners prefer to charge in this mode because of the significantly reduced charging time.

DC charging is mainly used for fast charging. An off-board charger converts the AC to DC to charge the battery. According to the US SAE standard, DC charging is categorized into DC Level 1 and DC level 2. In the DC Level 1 mode, DC charging current can reach 80 A, and charging power attains 36 kW. It takes 1.2 h to charge a battery from SOC 20% to full charge. In the DC Level 2 mode, the DC charging current can reach up to 200 A, charging power attains up to 90 kW, and it takes only 20 min to

charge the battery from SOC 20% to 80%. DC charging is mostly used in public charging stations, such as at gas stations for fuel vehicles, and is employed for charging EVs during long-distance driving, or for fast charging of public vehicles.

SAE J1772 is also known as a “J plug”, which became a standard piece equipment in the U.S. market. Figure 6 shows the SAE J1772 and the new J1772 combo connector, which can be used for both AC and DC charging. The SAE J1773 supplies the minimum interface compatibility demands for EV inductively coupled charging in the same regions. This kind of inductively coupled charging is expected to transfer energy at higher frequencies than power frequencies [95]. SAE J2954 was published in 2017 and provided the first worldwide standard for wireless power transfer for EVs with an 11-kW power level. Wireless charging with an 11-kW power level is a milestone of commercialization for EVs.

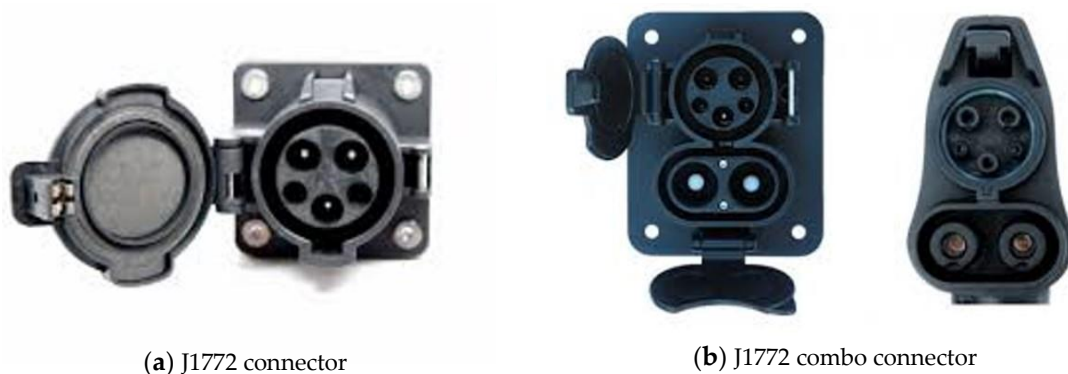

Figure 6. SAE J1772 connector.

Compared to the SAE standards, which classify charging ratings in “levels”, IEC employs “types” and “modes” for charging standards. In IEC 62196-2, EV connecting systems are classified into a few types [96]. The connector for type 1 is known as a “Yazaki connector” or “J1772” connector. For type 2, the “Mennekes connector” is used mainly in the EU, in which the original design was made by the manufacturer Mennekes. IEC 61851 proposed four modes of BEV charging from an external power grid, three of which were for AC charging and the last for DC charging.

A Japanese protocol named “CHAdeMO” has been presented for DC fast charging and a EV battery can be recharged to SOC 80% within 30 min using DC charging at 50 kW. The CHAdeMO standard was published as a Japanese national standard in October 2012.

China, as the biggest EV market in the world, has developed its own charging standards. In 2018, the China Electricity Council and the Japan Fast Charge Association for Electric Vehicles signed a memorandum of understanding of technology and standards for EV charging facilities. According to the agreement, the two parties will jointly study fast charging standards for battery-powered vehicles. The new system will be completed in 2020 and will be able to shorten the charging time to 10 minutes [97].

3.5. Comparison of Charging Technology

Conductive charging, inductive charging, and battery swapping are considered the three available charging options for BEV applications. Table 3 [62,73,78,80,88,89,92] summarizes the system parameters and shows the advantages and disadvantages of each three. Compared these three options, conductive charging is the most widely used charging approach. It is relatively simple and cheap [62], but people may suffer from electric shocks because of the aging components. Automatic Operation is also not applicable in conductive charging. In some harsh situations like underwater or dusty environment, the conductive charging would be unsafe. [73] Inductive charging technology offers a higher safety level. Since there is contactless between the charging unit and vehicle assembly, it is spark-free [80]. With inductive charging, the driver needs to park and make sure the position of vehicles precisely in the charging zone. It is user-friendly. The main disadvantages of inductive charging are lower charging efficiency and more expensive [85]. Inductive charging needs a longer time and requires

drive electronics and coils on both sides. Battery swap needs the shortest time to full batteries because it replaces the depleted battery with a fully charged one [87]. To be economically sound, there are still many challenges, such as: how many charging bays in the facility should be arranged; how many batteries in the system should be used; how many batteries should be recharged according to different periods; how to move the batteries among stations; how to return and recover the swapped batteries [92]. Also, how to swap heavyweight batteries is a common technical problem. To deal with this issue, special tools such as robotic arms and control system have been applied in the process of swapping heavyweight batteries [89]. Additionally, the lack of standardization for power batteries is the main obstacle of having a public battery swap station to charge all types of EVs.

Table 3. Characters of different charging methods.

Type	Charging Method	Electrical	Time	Cost (\$)	Advantages & Disadvantages
Opportunity (Level 1)	Conductive	120 V, 15 A	>10 h	500–880	Cheap, simple installation and usage, time consuming
Primary (Level 2)	Conductive	208–240 V, up to 80 A	2–12 h	150–3000	Required a dedicated equipment and a connection installation for household or communal, faster charging time
Fast charging (Level 3)	Conductive	400 V, 32 A	15–20 min	30,000–160,000	Required an off-board charger, influence of power grid, expensive
Stationary charging systems	Inductive	2–15 kW ¹ , 20 k–1 MHz ² , 100–500 mm ³	3–3.5 h	1500–3000	Required a power receiver attached to the car, a larger size of charger, misalignment tolerance
Dynamic charging systems	Inductive	0.3–25 kW ¹ , 20–100 kHz ² , 10–200 mm ³	depending on the length of charging track	1 million/km	Low efficiency, a limited amount of transferred energy
Battery swap station	Battery swapping	400 V ⁴ , 70–250 set ⁵	5 min	5–10 million	Fast, centralized charging of batteries, lack of standardization for power batteries, required special tools for battery swapping

¹ Power ² Switching frequency ³ Air gap ⁴ Charging voltage ⁵ Battery number.

With the development of charging technology, charging for EVs is becoming more efficient and convenient. Dynamic charging makes it possible to further extend the travel range and reduce the size of the battery pack. The smart grid eliminates the load impact of EV charging and provides a better electricity distribution concept. The smart grid integration of EVs and smart EV charging could offer a greater insight into the EV experience. As an important support of the EV application, the charging technology plays a crucial role.

4. Electric Motors

The electric motor sits at the core of the propulsion system in EVs, which converts the electrical energy of the battery into mechanical energy to power the vehicles. The main requirements listed in the references [98,99] for propulsion motors are toughness, high torque, high power, high efficiency, a wide range of speed, robustness, ease of control, low cost, low noise, and small size. Several types of electric motors with different construction and technology have been used for EVs. These include induction motor (IM), permanent magnet (PM) and switched reluctance motors (SRMs). The most design to meet the demands of the automotive is the PM type [98].

4.1. Induction Motor

IMs were applied in the General Motor EV1 [93] with good performance. They are also being employed in Tesla EVs, such as the Roaster and Model S. Because of their reliability, robustness, less maintenance, mature technology, and low price, an IM is a reasonable choice for EV applications

in all commutator-less motors [100]. The main disadvantage of IMs is the low efficiency at light loads [101]. To ensure IMs meet the requirements of EV systems, vector control is used. Vector control, also called field-oriented control (FOC), and which brought a fundamental change in the control of the IM [102], can provide a wide range of speed up to 3–4 times base speed; however, the high-speed range efficiency may suffer. This control scheme can reduce the total losses under any loading condition by controlling the currents of the stator and rotor [103]. In addition to FOC [100], direct torque control (DTC) is also a popular control concept of IMs. DTC has a simple control structure and can control the instantaneous torque in the steady-state or transient operation moments [104,105]. Since an EV drive system must feature a fast torque response, low cost, and reliability, DTC is considered to be optimal for EV applications [106–108].

4.2. Permanent Magnet Brushless DC Motor (PMBLDC)

PMBLDCs are broadly employed in EVs because of their high-power density and high efficiency. High-quality rare earth permanent magnet materials, such as samarium cobalt (Sm–Co) and neodymium–iron–boron (Nd–Fe–B), have been used on its rotor [102]. As the rotor has no windings, no rotor copper loss exists [100]. Instead of a commutator and brush gear, the commutation of the PMBLDC is achieved by electronic switches, which provide synchronous current to the motor winding with the rotor position [14,109–111]. The rotor position can be sensed by Hall sensors, resolvers, or optical encoders since it is important for controlling the PMBLDC [112]. Position sensors make the motor more expensive, bigger, and more difficult to control. To reduce the overall cost of propulsive devices, control techniques without sensors are normally applied [113]. The sensor-less control system uses more complex control algorithms and more complicated electronics [114]. Sundeeep et al. [115] presented a new mechanical control technique without sensors. In this control technique, the commutation moments even at low speed are determined by an H function, which is not related to speed. Singh et al. [116] proposed using the back-EMF (electromotive force) sensing method to achieve sensor-less control for PMBLDC motors, which are simple and cost-effective, and can generate commutation pulses without any filtering or phase shift. Kumar et al. [117] discussed a method of deriving the rotor position from the output of the motor and using the position to determine the rotor speed in a closed-loop speed control scheme for a PMBLDC motor. Since the PMBLDC motor has the characteristics of a wide range of speed, high efficiency, controllability, and safety, it has drawn a significant amount of attention for EV applications, especially related to the in-wheel technology of electric propulsion systems [101].

4.3. Permanent Magnet Synchronous Motor (PMSM)

The PMSM is a preferred option in comparison with other motors for propulsion systems due to its high-power density, high efficiency, and simple structure [118–122]. PMSMs can be categorized into two types: interior permanent magnet synchronous motor (IPMSM) and surface mounted permanent magnet synchronous motor (SM-PMSM). Unlike an IPMSM, the SM-PMSM has a simpler construction, lower inertia of the rotor, and easier control. Due to these advantages, the SM-PMSM has been applied in several EV applications [123,124]. Some PMSM control methods are discussed in the scientific literature, such as DTC [125–127], predictive control [128], and adaptive structures [129,130]. However, FOC is the most popular control strategy used for PMSM drives [131–135]. Arias et al. [136] studied the impact of the speed in the FOC structure and proposed an adaptive control algorithm to extend the speed operation. Miranda et al. [137] showed a self-sensor technique for an SM-PMSM with high-frequency voltage injection, with which the rotor position and velocity can be determined. Monteiro et al. [138] proposed a method to reduce electromagnetic torque ripple and copper losses in an SM-PMSM and showed that their proposal can improve the performance of this kind of machine. The main disadvantages of the PMSM are its high cost and the demagnetization of permanent magnet materials in harsh environments, such as high temperature and vibration. In addition, the lack of

rare earth permanent magnet materials, particularly in regions without abundant rare earth resources, is the biggest challenge to the use of PMSMs in propulsion systems for many countries [134–137].

4.4. Switched Reluctance Motor

Switched reluctance motors have drawn increasing attention for EV application, not only because of their excellent performance, simple structure, low cost, robustness, and fault tolerance, but also because they do not employ rare-earth materials, which means SRM do not suffer the disadvantages of high price and environmental damage involved with mineral extraction and refining [138,139]. Although there are many advantages of SRMs compared to other traditional AC machines, they have an obvious disadvantage—acoustic noise—which results from radial vibration and torque ripple. Hence, reducing noise is the main concern in research of SRMs [99]. To mitigate the noise, motor topology improvement and control strategy design have been investigated. Jing et al. [140] explored a new type of rotor profile to minimize the torque ripple of the SRM. Millithaler et al. [141] employed an optimized viscoelastic resin to encapsulate/pot an SRM stator for reducing the noise in operation. Klein-Hessling et al. [142] used a search algorithm to forecast proper reference values for each phase to keep torque and overall radial force balanced at any time and remove two central drawbacks of SRMs. Shin et al. [143] proposed a modified method based on the two-stage commutation analysis to decrease the vibration and noise not related to the operating condition.

5. Charging Infrastructure

Charging infrastructure plays an important role in EV adoption. The implementation of electromobility requires that the establishment of a robust charging infrastructure network be taken into account [144–146]. Building a robust charging infrastructure network involves coordinating the current status of charging infrastructure, understanding the impact of charging on the power grid and considering the realization of a reasonable charging payment system [144,147,148].

5.1. Organization of Charging Infrastructure

In relation to the “chicken-and-egg” problem for EV implementation, charging infrastructure has been promoted by governments in many countries, especially those with high EV stocks. The availability of access to public charging infrastructure differs widely at regional level [144]. In the U.S., charging infrastructure was initially established with the support of the American Recovery and Reinvestment Act of 2009, which supplied federal funding through some EV infrastructure programs to build up about 18,000 public charging points in the U.S. between 2010 and 2013. Since then, different federal, state and private agencies have begun to invest in the construction of charging infrastructure [144]. In Europe, the stakeholders in charging infrastructure included governments, auto manufactures, energy companies and private charge-point providers. Norway, as the EV sales market leader in Europe, has faced challenges involving charging infrastructure. Their government played a key role in the construction of charging infrastructure and will continue to invest in the field. To decrease Green-House Gas (GHG) emissions, a Norway agency, Transnova (also called “Enova”) has steadily funded Norway’s charging infrastructure with six million Euros since 2009. The Office of Low Emission Vehicles (LOEV) of the UK government funded the buildout of public charging station by covering 75% of the hardware costs through a set of programs. In addition, as part of their Road Investment Strategy, the UK planned to build charging points every 30 km along the major road network [144]. In the Netherlands, some kind of charging network was already in place in several cities. Much of the initial charging infrastructure was funded by ELaadNL, a foundation associated with six energy network companies in the Netherlands. Moreover, the Netherlands government has invested over 16 million Euros in construction of charging infrastructure since 2011 to ensure the availability of charging points for all residences [144,147]. In Asia, the expansion in the number of charging points in China has been impressive in recent years, especially in Shanghai, Beijing, and Shenzhen, which are pilot cities funded by the central government. These cities aim to have one charging point for every eight EVs and wish to

establish high density charging networks in downtown areas. The Japanese government have funded the installation of charging stations around various cities and across their highway road network since 2013 through their “Next Generation Vehicle Charging Infrastructure Development Promotion Project” [144,146]. More than 7500 stations have now been included in Japan’s charging network, which is constructed by the Japanese Bank, auto manufacturers and power companies. With the sustained promotion of governments, preliminary charging networks have been built up in different countries and regions, particularly in metropolitan areas. Figure 7 [144,147] shows the current status of public charging points in several metropolitan areas around the world.

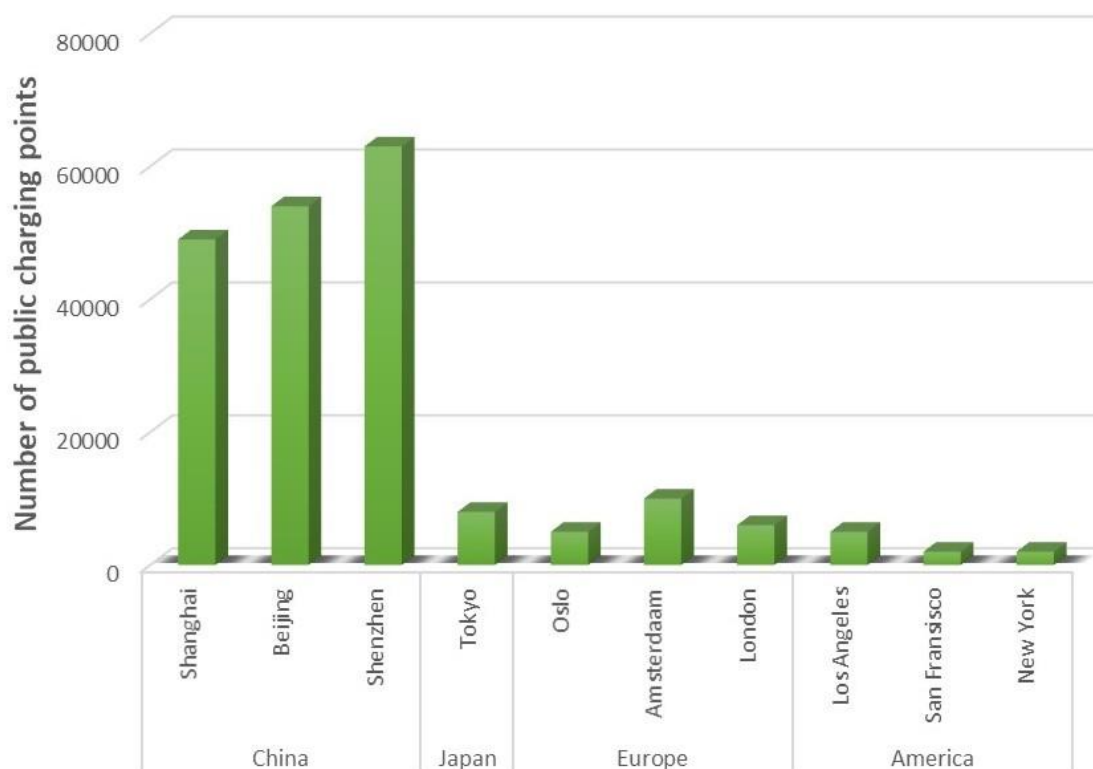

Figure 7. Number of public charging points in metropolitan areas.

To further promote their EV charging networks, many countries have proposed various programs and projects to financially and politically support the construction of charging infrastructure [144,149]. China has chosen 88 pilot cities funded by the central government to quickly build up a charging network. Both national utilities (like State Grid) and local governments took part in the construction of charging stations in China. The Japanese government and major auto manufacturers have funding charging infrastructure. The national charging network “Nippo Charge Service” (NCS) is supported by investment funds from Japanese bank, automakers and power companies. Germany tried to speed up the development of its charging infrastructure to match its ambitions in the EV market. The German government has funded more than 200 projects in “model regions” and recently announced a new major program to accelerate the building of charging networks. The Netherlands has a good foundation of charging infrastructure because of the continuous and strong support of their government. The Netherlands proposed some promotional programs like “Electric Mobility Gets Up to Speed” and “Green Deal” to maintain itself at the forefront of charging infrastructure. In the United Kingdom, some charging infrastructure schemes like “On-Street Residential Charge-point” and “Plugged-In-Midlands” were operated by OLEV. Moreover, the UK has been funded by the European Union (EU) to provide rapid chargers in the UK’s road network. The build-out of charging stations in the United States was supported through some EV projects of the U.S. Department of Transportation. California, as a regional government, has led the deployment of charging infrastructure. Table 4 summarizes the

current programs in various countries [144]. Other information, such as budget and form of funding, also shows the determination of governments to install charging infrastructure.

Table 4. Summary of major charging infrastructure programs in several countries.

Country	Program	Budget and Form of Support
China	Expansion of infrastructure in pilot cities Fast charging plaza and corridors by State Grid Investment by auto manufactures	Utility program in national level Collaboration of government and private partner Financial subsidies to local government
Japan	Next Generation Vehicle Charging Infrastructure Development Promotion Project Nippo Charge service	1 billion US dollars budget Collaboration of government and private partner
Germany	Nationwide promotion program for EV	300 million Euros budget Subsidies to cover 60% cost of authorized business
Netherlands	Electric Mobility Gets Up to Speed Green Deal	33 million Euros budget Incentives from local government
United Kingdom	Plugged-In Places Go Ultra Low	32 million dollars budget Incentives to cover 75% cost of charging station buildout Legislative measures
United States	Funding through American Recovery and Reinvestment Act Transportation Investment Generating Economic Recovery program	15 million dollars budget Federal funding for local government

5.2. The Challenges of Charging Networks

The establishment of charging networks not only promotes the implementation of EVs, but also presents many challenges for public policy. The main issues are the impact of charging on the power grid and the placement of charging infrastructure [144–146,148]. The former will affect the stability of the power grid and the cost of charging [148,150]. The latter may influence the efficiency of the charging network and the prospects for future investment and support [146,147,151]. Research has been conducted in both fields.

The build-out of charging infrastructure networks poses a risk to power grids due to the increasing charging loads. The potential of EV charging to use such a large amount of electricity is a challenge to utilities. Some studies have focused on the impact of EV charging on power grids and have tried to find better grid-charging interactions. Wang et al. [152] established a charging model to balance the convenience and cost to EV users and proposed an algorithm to divide the daytime hours into time gaps and schedule the charging operation of these time gaps. Chung et al. [153] focused on scheduling problems of EV charging and applied an efficient load predicting method to achieve an optimal combination of charging cost and convenience. Teng et al. [154] designed a fully decentralized-control EV charger to eliminate the impact of EV charging on power grids. A smart charger which adjusts the charging current was proposed by Liao et al. [155] to decrease charging impacts on a grid. As an energy aggregator, EV batteries can also inject electricity into the power grid. The impact on EV batteries in the vehicle-to-grid strategy has not been investigated deeply. M Dubarry et al. conducted a study to understand the impact of two-way charging on Lithium-ion batteries in EVs [156].

Although the advantages of EVs are undoubted for the great majority from the green community, the necessity of the creation of such recharging infrastructure and its cost makes the issue not that evident. To address these issues, the deployment and the cost reduction of charging infrastructure should be considered [145,146]. An optimal location of charging infrastructure at a local level not only assists to maximize the usage, avoid traffic and parking issues, and minimize stress on the power grid, but also contributes to the return of investment [144]. The cost of charging infrastructure has

been declined over the past years due to the new technological innovation and large-scale effect [144]. For example, in Amsterdam, the costs of curbside charging stations have been fallen from \$13,000 to \$2,200 per station since 2009 [144]. The reasonable placement and the cost of charging infrastructure are not only important for charging convenience but are also crucial to network charging efficiency which has a potential impact on future investment. In the paper of He et al. [157], a double-level programming model was suggested to find the best charging station placement by taking the driving range of EVs in to account. Tang et al. [158]. identified important parameters that affect the optimal location of EV charging stations by establishing a non-deterministic polynomial model and applying a simulation algorithm. Due to the critical role of infrastructure in supporting EV penetration, Zhou [159] has analyzed some important factors affecting the regulation of charging stations. To reduce obstacles in the adoption of EVs, such as range anxiety and distance deviations, Guo et al. [160] applied an adaptive search and k-shortest path algorithm.

While EVs are often considered as “green” due to negligible GHG emissions, the power generators in coal or gas electric stations that are used to produce electricity for batteries recharging emit rich GHGs [161]. The price and extra GHG emission which accompanies the power production for EV need additional consideration. Some researchers focused on this issue. Traut et al. [162] proposed that GHG reduction potential of EV concerned with charging methods, charging infrastructure and electricity generation mix. In the paper of Kim et al. [163] a comprehensive model was designed to estimates the energy load and GHG emission impact in the future. Providing renewable energy for EV charging is a way to reduce the GHG emission of EVs. Nienhueser et al. [164] assessed the economic and environmental benefits of charging EV with renewable energy. Jin et al. [165] presented in the paper the result of their study on allocating energy from renewable sources to EVs in a cost-efficient mode.

5.3. Possibility of Fair Payment for EV Charging

The possibility of fair payment for EV charging is also an important point for EVs, because it depends on the battery state and age. A battery management system (BMS) can help to obtain data regarding battery status. Every driver should know how long they will be able to use a car after charging. Other factors such as battery capacity, charging speed and electricity price should also be taken into account [149,166]. A number of researchers have conducted studies in this field. Liu et al. [167] introduced a battery State-of-Health (SOH) estimation method in their paper to analyze the relationship between voltage and battery age. To get accurate information regarding State-of-Charge (SOC) and SOH of a battery, Cacciato et al. [168] proposed a new estimation method by strictly controlling parameters within a battery circuit model. Wang [169] implied a prognosis of the remaining energy in online BMS. In their paper, Melo et al. [170] suggested a robust algorithm for aggregation of scattered loads within the same power grid and proposed a compensation concept to be applied considering battery aging. Burnham et al. [171], discussed the need for fast charging to help overcome the obstacles of EV adoption, although some economic and infrastructure issues existed. To minimize the total charging time, Tian et al. [172] helped taxi drivers with a real-time recommendation system for charging stations.

6. Emerging Technologies for the Future Development of EVs

EV technologies have been developed very quickly in recent years. In addition to low emissions, more benefits are desired from EVs. With advanced technologies being applied to transportation and real-time communication, such as vehicle-to-vehicle (V2V), vehicle-to-infrastructure (V2I), vehicle-to-pedestrian (V2P), and vehicle-to-grid (V2G), enhanced traffic safety and efficiency can be realized [168]. Communication between vehicles and any smart device at the roadside is known as vehicle-to-everything (V2X) [173,174]. As a part of V2X, V2I communication can improve driving performance by making velocity decisions based on knowledge of traffic light distance and time gap and reducing the starting and stopping frequency of vehicles to make driving smoother and steadier [174]. The batteries of EVs can be considered either as loads or as a distributed energy

and power resource in V2G. A V2G-capable vehicle offers various features, such as regulated active power, provision for reactive power, load smoothing, and elimination of current harmonics. The cost of V2G includes battery degradation, a communication fee between the EV and the grid, impacts on grid distribution equipment, and infrastructure changes. Study shows that economic profits of V2G technologies have received increased attention from grid operators and EV owners, and are heavily related to the strategies of charging and vehicle aggregation [175,176]. V2P communication systems for safety or convenience have also attracted increasing attention. Recent research shows that different V2P systems have employed different communication technologies and mechanisms to face different users [177]. The main motivations of V2X are road safety, traffic efficiency, and energy savings. However, this technology is still in an exploratory stage and faces several challenges, such as cybersecurity and traffic safety brought about by V2X applications [178,179]. Moreover, the integration of artificial intelligence (AI) and V2X has also drawn the attention of some researchers [180].

Although EVs have attracted significant interest recently, numerous technical difficulties remain which are crucial for the promotion of EV development. Those challenges are summarized in Table 5. One of the key barriers is the research and mass production of batteries, which have a high energy density, high power density, and safety.

Table 5. Challenges for EV technology development.

Challenge	System	Future Development
Improve the battery characteristics	Battery	Higher capacity, higher energy density, safety, more efficient battery management, new battery such as graphene battery
High cost, toxic material in the battery	Battery	Long-life-cycle, battery recycling
Elimination of range anxiety	Charging	Fast charging, charging standard
DWPT	Charging	Higher efficiency, power converter, compensation topology, emerging coil material, foreign object detection and communication, the health and safety concerns of the WPT system
Adoption of battery swapping	Charging infrastructure	Optimal distribution of BSS, energy and ancillary service to the distribution grid
Enhance the characteristics of PMSM	Electric motor	Reduce the impact of demagnetization of permanent material, more reliable
Lower efficiency and lower power density of induction motor	Electric motor	DTC, copper rotor induction motor

Numerous researchers have carried out large-scale studies on this topic [181]. At present, the most widely-used batteries in EVs are lithium-ion batteries, but whether lithium-ion batteries are truly green remains a question. The existing cathode material of a lithium-ion battery contains cobalt or nickel, both of which are expensive and highly toxic. The mass production of lithium-ion batteries for EVs will lead to the appearance of large volumes of contaminated waste and places. Future battery research should keep in mind the technical and economic feasibility of large-scale production [182]. The safety concern is another challenge for EV batteries. Recent news about fires of lithium-ion batteries of EVs highlights the importance of battery safety. Battery management could enhance the safety of huge battery packs in EVs and should be researched widely. To eliminate range anxiety, WPT, especially DWPT, provides the prospect of new opportunities for EVs to enhance sustainable mobility. At present, the system efficiency of dynamic WPT is not high enough, and the batteries cannot get enough energy due to limited track length and high speed of the vehicle. Large-scale charging infrastructure deployment is one of the requirements of the WPT application. A careful

evaluation of the environmental and economic impacts of large-scale charging infrastructure can help DWPT development [182,183]. The other technical challenges for EVs involve the coordination of the growth and development of EV technology in conjunction with other emerging technologies, such as AI and V2X.

7. Conclusions

This article presents a review of EV technology development in key fields, such as the battery, charging, the electronic motor, charging infrastructure and emerging technology. The development of battery technology is very important for EV penetration. In addition to the traditional lead–acid batteries, a wider range of battery types are being used in EVs. Nickel-metal hydride batteries, Zebra batteries, and lithium-ion batteries are employed as the power source of EVs because they have higher specific energy, higher power density, and are more environment-friendly. At present, lithium-ion batteries are most widely used. The usage of metal–air batteries and supercapacitors is still being researched, but may be a target for all EVs. The charging of batteries can help relieve range anxiety. To solve the problem of charging EVs, many efforts have been undertaken. On-board chargers have been designed with the characteristics of light weight, small size, high performance, and control simplicity. Conductive chargers with CV, CC, CC–CV or pulse charging currents aim to charge EVs faster, with reduced thermal stress and without over-voltage. Inductive charging provides the possibility to charge without the limit of the physical cable connection. Charging becomes more flexible and the cost of the EV can also be reduced using the technology of dynamic charging. Battery swapping is another alternative for efficient and hassle-free charging methods. BSS can not only offer a battery swapping service but also provide energy and ancillary services to the distribution grid. Charging standards are important for the charging technology. The most common charging standards are published by the US, the EU, Japan, and China, which have the largest EV stock in the world. As the core of the propulsion system, electric motors are also a concern of many researchers. IMs are being used in Tesla EVs. Vector control has been employed to improve the efficiency at light load for IMs. The rotor position is important for the controlling of PMBLDCs, which is usually undertaken with sensor-less control. Because of the advantages of high-power density and high efficiency, the PMBLDC is attractive for EV applications, especially in the field of in-wheel technology. PMSMs, especially the SM type, can be found in many EV applications. These have high power density, high efficiency, and simple structure, and use FOC as a torque control strategy. SRMs have attracted recent attention because they do not rely on rare earth materials, and are thus cheaper, while having an excellent performance to meet the needs for EVs. If the SRM problem of acoustic noise could be eliminated in the future, it would be widely used for EVs. Charging infrastructure plays a crucial role of EV applications. The organization of charging network, the technical challenges of infrastructure and possibilities of fair payment for charging are involved in the charging infrastructure network. At present, EVs act not only as a tool that can be used to transport people and goods, just as traditional vehicles, but also as a bridge that communicates between EVs and all smart devices. The new V2X technology has partly realized these communications. Although EV development must face many technical challenges, such as battery technology, charging technology, electric motor technology, and integration of other emerging technology, we believe that EVs will play an important role in people's lives in the future.

Author Contributions: Conceptualization, X.S. and Z.L.; resources, X.S. and X.W.; writing—original draft preparation, X.S.; writing—review and editing, X.S., X.W. and C.L. All authors have read and agreed to the published version of the manuscript.

Funding: This research received no external funding.

Conflicts of Interest: The authors declare no conflict of interest.

References

1. Qinyu, Q.; Fuquan, Z.; Zongwei, L.; Xin, H.; Han, H. Life cycle greenhouse gas emissions of Electric vehicles in China: Combining the vehicle cycle and fuel cycle. *Energy* **2019**, *177*, 222–233. [CrossRef]
2. Li, C.; Negnevitsky, M.; Wang, X.; Yue, W.L.; Zou, X. Multi-criteria analysis of policies for implementing clean energy vehicles in China. *Energy Policy* **2019**, *129*, 826–840. [CrossRef]
3. Wenbo, L.; Ruyin, L.; Hong, C. Consumers' evaluation of national new energy vehicle policy in China: An analysis based on a four paradigm model. *Energy Policy* **2016**, *99*, 33–41. [CrossRef]
4. Hu, Z.; Yuan, J. China's NEV market development and its capability of enabling premium NEV: Referencing from the NEV market performance of BMW and Mercedes in China. *Transp. Res. Part A Policy Pract.* **2018**, *118*, 545–555. [CrossRef]
5. Du, J.; Ouyang, D. Progress of Chinese electric vehicles industrialization in 2015: A review. *Appl. Energy* **2017**, *188*, 529–546. [CrossRef]
6. Siqin, X.; Junping, J.; Xiaoming, M. Comparative Life Cycle Energy and GHG Emission Analysis for BEVs and pHVs: A Case Study in China. *Energies* **2019**, *12*, 834. [CrossRef]
7. Gong, H.; Wang, M.Q.; Wang, H. New energy vehicles in China: Policies, demonstration, and progress. *Mitig. Adapt. Strateg. Glob. Chang.* **2013**, *18*, 207–228. [CrossRef]
8. Steffen, B.; Jan, T.; Ulrich, F. Perspectives of electrical mobility: Total cost of ownership of electric vehicles in Germany. *Transp. Policy* **2016**, *50*, 63–77. [CrossRef]
9. Massiani, J. Cost-benefit analysis of policies for the development of electric vehicles in Germany: Methods and results. *Transp. Policy* **2015**, *38*, 19–26. [CrossRef]
10. Palmer, K.; Tate, J.E.; Wadud, Z.; Nellthorp, J. Total cost of ownership and market share for hybrid and electric vehicles in the UK, US and Japan. *Appl. Energy* **2018**, *209*, 108–119. [CrossRef]
11. She, Z.Y.; Sun, Q.; Ma, J.J.; Xie, B.C. What are the barriers to widespread adoption of Battery electric vehicles? A survey of public perception in Tianjin, China. *Transp. Policy* **2017**, *56*, 29–40. [CrossRef]
12. Guarnieri, M. Looking back to electric cars. In Proceedings of the 2012 Third IEEE History of Electro-Technology Conference (HISTELCON), Pavia, Italy, 5–7 September 2012; pp. 1–6.
13. Chan, C.C. The rise & fall of electric vehicles in 1828–1930: Lessons learned [scanning our past]. *Proc. IEEE* **2012**, *101*, 206–212. [CrossRef]
14. Rajashekara, K. History of electric vehicles in General Motors. *IEEE Trans. Ind. Appl.* **1994**, *30*, 897–904. [CrossRef]
15. History of the Electric Vehicle. Available online: https://en.wikipedia.org/wiki/History_of_the_electric_vehicle (accessed on 12 August 2019).
16. 1 Million Pure EVs Worldwide: EV Revolution Begins! Available online: <https://cleantechnica.com/2016/11/22/1-million-ev-revolution-begins/> (accessed on 22 November 2016).
17. Electric and Plug-In Hybrid Cars Whiz Past 3m Mark Worldwide. Available online: <https://www.theguardian.com/environment/2017/dec/25/electric-and-plug-in-hybrid-cars-3m-worldwide> (accessed on 25 December 2017).
18. Global Top. Available online: <http://ev-sales.blogspot.com/2019/01/global-top-20-december-2018.html> (accessed on 20 December 2018).
19. Mersky, A.C.; Sprei, F.; Samaras, C.; Qian, Z.S. Effectiveness of incentives on electric vehicle adoption in Norway. *Transp. Res. Part D* **2016**, *46*, 56–68. [CrossRef]
20. Matthews, L.; Lynes, J.; Riemer, M.; Del Matto, T.; Cloet, N. Do we have a car for you? Encouraging the uptake of electric vehicles at point of sale. *Energy Policy* **2017**, *100*, 79–88. [CrossRef]
21. Das, H.S.; Tan, C.W.; Yatim, A.H. Fuel cell hybrid electric vehicles: A review on power conditioning units and topologies. *Renew. Sustain. Energy Rev.* **2017**, *76*, 268–291. [CrossRef]
22. Hydrogen. Available online: <https://www.iea.org/tcep/energyintegration/hydrogen/> (accessed on 15 May 2019).
23. Boqiang, L.; Wei, W. Why people want to buy electric vehicle: An empirical study in first-tier cities of China. *Energy Policy* **2018**, *112*, 233–241. [CrossRef]
24. Andwari, A.M.; Pesiridis, A.; Rajoo, S.; Martinez-Botas, R.; Esfahanian, V. A review of Battery Electric Vehicle technology and readiness levels. *Renew. Sustain. Energy Rev.* **2017**, *78*, 414–430. [CrossRef]

25. Un-Noor, F.; Padmanaban, S.; Mihet-Popa, L.; Mollah, M.N.; Hossain, E. A Comprehensive Study of Key Electric Vehicle Components, Technologies, Challenges, Impacts, and Future Direction of Development. *Energies* **2017**, *10*, 1217. [CrossRef]
26. Coffman, M.; Bernstein, P.; Wee, S. Electric vehicles revisited: A review of factors that affect adoption. *Transp. Rev.* **2017**, *37*, 79–93. [CrossRef]
27. Liao, F.; Molin, E.; van Wee, B. Consumer preferences for electric vehicles: A literature review. *Transp. Rev.* **2017**, *37*, 252–275. [CrossRef]
28. Yong, J.Y.; Vigna, K.R.; Tan, K.M.; Mithulananthan, N. A review on the state-of-the-art technologies of electric vehicle, its impacts and prospects. *Renew. Sustain. Energy Rev.* **2015**, *49*, 365–385. [CrossRef]
29. Cuma, M.U.; Koroglu, T. A comprehensive review on estimation strategies used in hybrid and battery electric vehicles. *Renew. Sustain. Energy Rev.* **2015**, *42*, 517–531. [CrossRef]
30. Groger, O.; Gasteiger, H.A.; Suchsland, J.P. Review-Electromobility: Batteries or Fuel Cells? *J. Electrochem. Soc.* **2015**, *162*, A2605–A2622. [CrossRef]
31. Hannan, M.A.; Lipu, M.S.H.; Hussain, A.; Mohamed, A. A review of lithium-ion battery state of charge estimation and management system in electric vehicle applications: Challenges and recommendations. *Renew. Sustain. Energy Rev.* **2017**, *78*, 834–854. [CrossRef]
32. Pelegov, D.; Pontes, J. Main Drivers of Battery Industry Changes: Electric Vehicles—A Market Overview. *Batteries* **2018**, *4*, 65. [CrossRef]
33. Saxena, S.; Le Floch, C.; MacDonald, J.; Moura, S. Quantifying EV battery end-of-life through analysis of travel needs with vehicle powertrain models. *J. Power Sources* **2015**, *282*, 265–276. [CrossRef]
34. Alshahrani, S.; Khalid, M.; Almuhaini, M. Electric Vehicles Beyond Energy Storage and Modern Power Network: Challenges and Applications. *IEEE Access* **2019**, *7*, 99031–99064. [CrossRef]
35. Nykvist, B.; Nilsson, M. Rapidly falling costs of battery packs for electric vehicles. *Nat. Clim. Chang.* **2015**, *5*, 329–332. [CrossRef]
36. Reddy, T.B. *Linden's Handbook of Batteries*; McGraw-Hill: New York, NY, USA, 2011; pp. 167–201.
37. Toyota to Make Over 10 Battery EV Models in Early 2020s. Available online: <https://www.cnbc.com/2017/12/18/toyota-to-make-over-10-battery-ev-models-in-early-2020s.html> (accessed on 18 December 2017).
38. Horkos, P.G.; Yammine, E.; Karami, N. Review on different charging techniques of lead-acid batteries. In Proceedings of the 2015 Third International Conference on Technological Advances in Electrical, Electronics and Computer Engineering (TAECE), Beirut, Lebanon, 29 April–1 May 2015; pp. 27–32. [CrossRef]
39. May, G.J.; Davidson, A.; Monahov, B. Lead batteries for utility energy storage: A review. *J. Energy Storage* **2018**, *15*, 145–157. [CrossRef]
40. Tie, S.F.; Tan, C.W. A review of energy sources and energy management system in electric vehicles. *Renew. Sustain. Energy Rev.* **2013**, *20*, 82–102. [CrossRef]
41. Chau, K.T.; Wong, Y.S.; Chan, C.C. An overview of energy sources for electric vehicles. *Energy Convers. Manag.* **1999**, *40*, 1021–1039. [CrossRef]
42. Electrical Energy Storage. White paper. In Proceedings of the International Electrotechnical Commission (IEC), Geneva, Switzerland, 14 November 2011; Available online: <https://www.iec.ch/whitepaper/energystorage/> (accessed on 11 November 2019).
43. Li, G.S.; Lu, X.C.; Kim, J.Y.; Meinhardt, K.D.; Chang, H.J.; Canfield, N.L.; Sprenkel, V.I. Advanced intermediate temperature sodium-nickel chloride batteries with ultra-high energy density. *Nat. Commun.* **2016**, *7*, 10683. [CrossRef] [PubMed]
44. Hannan, M.A.; Hoque, M.M.; Mohamed, A.; Ayob, A. Review of energy storage systems for electric vehicle applications: Issues and challenges. *Renew. Sustain. Energy Rev.* **2017**, *69*, 771–789. [CrossRef]
45. Khalgh, A.; Li, Z.H. Battery, Ultracapacitor, Fuel Cell, and Hybrid Energy Storage System for Electric, Hybrid Electric, Fuel Cell, and Plug-in Hybrid Electric Vehicles: State of the Art. *IEEE Trans. Veh. Technol.* **2010**, *59*, 2806–2824. [CrossRef]
46. Chen, A.X.; Sen, P.K. Advancement in battery technology: A state-of-the-art review. In Proceedings of the Industry Applications Society Annual Meeting (IAS), Portland, OR, USA, 2–6 October 2016. Accession Number: 16447436. [CrossRef]
47. Shen, Y.; Noréus, D.; Starborg, S. Increasing NiMH battery cycle life with oxygen. *Int. J. Hydrog. Energy* **2018**, *43*, 18626–18631. [CrossRef]

48. Manzetti, S.; Mariasiu, F. Electric vehicle battery technologies: From present state to future systems. *Renew. Sustain. Energy Rev.* **2015**, *51*, 1004–1012. [[CrossRef](#)]
49. Ding, Y.; Cano, Z.P.; Yu, A.; Lu, J.; Chen, Z. Automotive Li-Ion Batteries: Current Status and Future Perspectives. *Electrochem. Energy Rev.* **2019**, *2*, 1–28. [[CrossRef](#)]
50. Bresser, D.; Hosoi, K.; Howell, D.; Li, H.; Zeisel, H.; Amine, K.; Passerini, S. Perspectives of automotive battery R&D in China, Germany, Japan, and the USA. *J. Power Sources* **2018**, *382*, 176–178. [[CrossRef](#)]
51. Lee, J.H.; Yoon, C.S.; Hwang, J.Y.; Kim, S.J.; Maglia, F.; Lamp, P.; Myung, S.T.; Sun, Y.K. High-energy-density lithium-ion battery using a carbon-nanotube-Si composite anode and a compositionally graded Li[Ni_{0.85}Co_{0.05}Mn_{0.10}]O₂ cathode. *Energy Environ. Sci.* **2016**, *9*, 2152–2158. [[CrossRef](#)]
52. Akhil, A.A.; Huff, G.; Currier, A.B.; Kaun, B.C.; Rastler, D.M.; Chen, S.B.; Cotter, A.L.; Bradshaw, D.T.; Gauntlett, W.D. DOE/EPRI 2013 Electricity Storage Handbook in Collaboration with NRECA. In *Sandia Report, Sand*; Sandia National Laboratories: Albuquerque, NM, USA, 2013; pp. 201–213.
53. Nazri, G.A.; Pistoia, G. *Lithium Batteries: Science and Technology (Paperback)*; Springer: Berlin, Germany, 2009; pp. 455–478.
54. Kucinskis, G.; Bajars, G.; Kleperis, J. Graphene in lithium ion battery cathode materials: A review. *J. Power Sources* **2013**, *240*, 66–79. [[CrossRef](#)]
55. Son, I.H.; Park, J.H.; Park, S.; Park, K.; Han, S.; Shin, J.; Doo, S.G.; Hwang, H.; Choi, J.W. Graphene balls for lithium rechargeable batteries with fast charging and high volumetric energy densities. *Nat. Commun.* **2017**, *8*, 1561. [[CrossRef](#)] [[PubMed](#)]
56. Suberu, M.Y.; Mustafa, M.W.; Bashir, N. Energy storage systems for renewable energy power sector integration and mitigation of intermittency. *Renew. Sustain. Energy Rev.* **2014**, *35*, 499–514. [[CrossRef](#)]
57. Veneri, O.; Capasso, C.; Patalano, S. Experimental study on the performance of a Zebra battery based propulsion system for urban commercial vehicles. *Appl. Energy* **2017**, *185 Pt 2*, 2005–2018. [[CrossRef](#)]
58. Lu, L.; Han, X.; Li, J.; Hua, J.; Ouyang, M. A review on the key issues for lithium-ion battery management in electric vehicles. *J. Power Sources* **2013**, *226*, 272–288. [[CrossRef](#)]
59. Kouchachvili, L.; Yaici, W.; Entchev, E. Hybrid battery/supercapacitor energy storage system for the electric vehicles. *J. Power Sources* **2018**, *374*, 237–248. [[CrossRef](#)]
60. Stokes, L.C.; Breetz, H.L. Politics in the U.S. energy transition: Case studies of solar, wind, biofuels and electric vehicles policy. *Energy Policy* **2018**, *113*, 76–86. [[CrossRef](#)]
61. Dominkovića, D.F.; Bačekovičb, I.B.; Pedersena, A.S.; Krajačić, G. The future of transportation in sustainable energy systems: Opportunities and barriers in a clean energy transition. *Renew. Sustain. Energy Rev.* **2018**, *82*, 1823–1838. [[CrossRef](#)]
62. Rahman, I.; Vasant, P.M.; Singh, B.S.M.; Abdullah-Al-Wadud, M.; Adnan, N. Review of recent trends in optimization techniques for plug-in hybrid, and electric vehicle charging infrastructures. *Renew. Sustain. Energy Rev.* **2016**, *58*, 1039–1047. [[CrossRef](#)]
63. Electric Light & Power [Internet]. IEC Publishes Two International EV Standards. Available online: <http://www.elp.com/articles/2011/10/iec-publishes-two-international-ev-standards.html> (accessed on 19 October 2011).
64. China and Japan Plan to Develop a Unified Standard for Electric Vehicle Charging. Available online: <http://www.mofcom.gov.cn/article/i/jyj/m/201808/20180802778707.shtml> (accessed on 23 August 2018).
65. Li, B.; Lee, F.C.; Li, Q.; Liu, Z. Bi-directional on-board charger architecture and control for achieving ultra-high efficiency with wide battery voltage range. In Proceedings of the 2017 IEEE Applied Power Electronics Conference and Exposition (APEC), Tampa, FL, USA, 26–30 March 2017; pp. 2470–6647. [[CrossRef](#)]
66. Whitaker, B.; Barkley, A.; Cole, Z.; Passmore, B.; Martin, D.; McNutt, T.R.; Lostetter, A.B.; Lee, J.S.; Shiozaki, K. A High-Density, High-Efficiency, Isolated On-Board Vehicle Battery Charger Utilizing Silicon Carbide Power Device. *IEEE Trans. Power Electron.* **2014**, *29*, 2606–2617. [[CrossRef](#)]
67. Shin, C.J.; Lee, J.Y. An Electrolytic Capacitor-less Bi-Directional EV On-Board Charger Using Harmonic Modulation Technique. *IEEE Trans. Power Electron.* **2014**, *29*, 5195–5203. [[CrossRef](#)]
68. Tera, T.; Taki, H.; Shimizu, T. Loss Reduction of Laminated Core Inductor used in On-board Charger for EVs. *J. Ind. Appl.* **2015**, *4*, 626–633. [[CrossRef](#)]
69. Kisacikoglu, M.C.; Kesler, M.; Tolbert, L.M. Single-Phase On-Board Bidirectional PEV Charger for V2G Reactive Power Operation. *IEEE Trans. Smart Grid* **2015**, *6*, 767–775. [[CrossRef](#)]

70. Bojrup, M.; Karlsson, P.; Alakula, M.; Simonsson, B. A dual purpose battery charger for electric vehicle. In Proceedings of the PESC 98 Record. 29th Annual IEEE Power Electronics Specialists Conference, Fukuoka, Japan, 22–22 May 1998. (Cat. No.98CH36196). [[CrossRef](#)]
71. Ota, Y.; Taniguchi, H.; Suzuki, H.; Nakajima, T.; Baba, J.; Yokoyama, A. Implementation of grid-friendly charging scheme to electric vehicle off-board charger for V2G. In Proceedings of the 3rd IEEE PES Innovative Smart Grid Technologies Europe (ISGT Europe), Berlin, Germany, 14–17 October 2012. [[CrossRef](#)]
72. Seung-Ki, S.; Sang-Joon, L. An integral battery charger for four-wheel drive electric vehicle. *IEEE Trans. Ind. Appl.* **1995**, *31*, 1096–1099. [[CrossRef](#)]
73. Muneret, X.; Coux, M.; Lenain, P. Analysis of the partial charge reactions within a standby VRLA battery leading to an understanding of intermittent charging techniques. In Proceedings of the INTELEC, Twenty-Second International Telecommunications Energy Conference, Phoenix, AZ, USA, 10–14 September 2000. (Cat. No.00CH37131). [[CrossRef](#)]
74. Chopra, S.; Bauer, P. Driving Range Extension of EV With On-Road Contactless Power Transfer-A Case Study. *IEEE Trans. Ind. Electron.* **2013**, *60*, 329–338. [[CrossRef](#)]
75. Li, S.; Mi, C.C. Wireless power transfer for electric vehicle applications. *J. Emerg. Sel. Top. Power Electron.* **2015**, *3*, 4–17. [[CrossRef](#)]
76. Choi, S.Y.; Gu, B.W.; Jeong, S.Y.; Rim, C.T. Advances in Wireless Power Transfer Systems for Roadway-Powered Electric Vehicles. *IEEE J. Emerg. Sel. Top. Power Electron.* **2015**, *3*, 18–36. [[CrossRef](#)]
77. Thai, V.X.; Choi, S.Y.; Choi, B.H.; Kim, J.H.; Rim, C.T. Coreless Power Supply Rails Compatible with Both Stationary and Dynamic Charging of Electric Vehicles. In Proceedings of the IEEE 2nd International Future Energy Electronics Conference (IFEEEC), Taipei, Taiwan, 1–4 November 2015. [[CrossRef](#)]
78. Onar, O.C.; Miller, J.M.; Campbell, S.L.; Coomer, C.; White, C.P.; Seiber, L.E. A Novel Wireless Power Transfer for In-Motion EV/PHEV Charging. In Proceedings of the Twenty-Eighth Annual IEEE Applied Power Electronics Conference and Exposition (APEC), Long Beach, CA, USA, 17–21 March 2013. [[CrossRef](#)]
79. Miller, J.M.; Onar, O.C.; Chinthavali, M. Primary-Side Power Flow Control of Wireless Power Transfer for Electric Vehicle Charging. *IEEE J. Emerg. Sel. Top. Power Electron.* **2015**, *3*, 147–162. [[CrossRef](#)]
80. Miller, J.M.; Onar, O.C.; White, C.; Campbell, S.; Coomer, C.; Seiber, L.; Sepe, R.J.; Steyerl, A. Demonstrating Dynamic Wireless Charging of an Electric Vehicle—The benefit of electrochemical capacitor smoothing. *IEEE Power Electron. Mag.* **2014**, 12–24. [[CrossRef](#)]
81. Miller, J.M.; Jones, P.; Li, J.-M.; Onar, O.C. ORNL Experience and challenges Facing Dynamic Wireless Power Charging of EV's. *IEEE Circuits Syst. Mag.* **2015**, *15*, 40–53. [[CrossRef](#)]
82. Miller, J.M.; White, C.P.; Onar, O.C.; Ryan, P.M. Grid Side Regulation of Wireless Power Charging of Plug-In Electric Vehicles. In Proceedings of the IEEE Energy Conversion Congress and Exposition (ECCE), Raleigh, NC, USA, 15–20 September 2012. [[CrossRef](#)]
83. Jones, P.; Onar, O. Impact of Wireless Power Transfer in transportation: Future transportation enabler or near term distraction. In Proceedings of the IEEE International Electric Vehicle Conference (IEVC), Florence, Italy, 17–19 December 2014. [[CrossRef](#)]
84. Onar, O.C.; Miller, J.M.; Campbell, S.L.; Coomer, C.; White, C.P.; Seiber, L.E. Oak Ridge National Laboratory Wireless Power Transfer Development for Sustainable Campus Initiative. In Proceedings of the IEEE Transportation Electrification Conference and Expo (ITEC), Detroit, MI, USA, 16–19 June 2013. [[CrossRef](#)]
85. Budhia, M.; Covic, G.; Boys, J. A New IPT Magnetic Coupler for Electric Vehicle Charging Systems. In Proceedings of the 36th Annual Conference on IEEE Industrial Electronics Society, Glendale, AZ, USA, 7–10 November 2010. [[CrossRef](#)]
86. Machura, P.; Li, Q. A critical review on wireless charging for electric vehicles. *Renew. Sustain. Energy Rev.* **2019**, *104*, 209–234. [[CrossRef](#)]
87. Sarker, M.R.; Pandzic, H.; Ortega-Vazquez, M.A. Electric vehicle battery swapping station: Business case and optimization model. In Proceedings of the 2013 International Conference on Connected Vehicles and Expo (ICCVE), Las Vegas, NV, USA, 2–6 December 2013; pp. 289–294. [[CrossRef](#)]
88. Avci, B.; Girotra, K.; Netessine, S. Electric vehicles with a battery switching station: Adoption and environmental impact. *Manag. Sci.* **2015**, *61*, 772–794. [[CrossRef](#)]
89. Ban, M.; Yu, J.; Li, Z.; Guo, D.; Ge, J. Battery Swapping: An aggressive approach to transportation electrification. *IEEE Electr. Mag.* **2019**, *7*, 44–54. [[CrossRef](#)]

90. Sarker, M.R.; Pandzic, H.; Ortega-Vazquez, M.A. Optimal Operation and Services Scheduling for an Electric Vehicle Battery Swapping Station. *IEEE Trans. Power Syst.* **2015**, *30*, 901–910. [[CrossRef](#)]
91. Yan, J.; Menghwar, M.; Asghar, E.; Panjwani, M.K.; Liu, Y.Q. Real-time energy management for a smart community microgrid with battery swapping and renewables. *Appl. Energy* **2019**, *238*, 180–194. [[CrossRef](#)]
92. Mahoor, M.; Hosseini, Z.S.; Khodaei, A. Least-cost operation of a battery swapping station with random customer requests. *Energy* **2019**, *172*, 913–921. [[CrossRef](#)]
93. Sultana, U.; Khairuddin, A.B.; Sultana, B.; Rasheed, N.; Qazi, S.H.; Malik, N.R. Placement and sizing of multiple distributed generation and battery swapping stations using grasshopper optimizer algorithm. *Energy* **2018**, *165*, 408–421. [[CrossRef](#)]
94. Zheng, J.; Mehndiratta, S.; Guo, J.Y.; Liu, Z. Strategic policies and demonstration program of electric vehicle in China. *Transp. Policy* **2012**, *19*, 17–25. [[CrossRef](#)]
95. Scott, H. Understanding the impact of reoccurring and non-financial incentives on plug-in electric vehicle adoption—A review. *Transp. Res. Part A Policy Pract.* **2019**, *119*, 1–14. [[CrossRef](#)]
96. Hao, H.; Ou, X.; Du, J.; Wang, H.; Ouyang, M. China’s electric vehicle subsidy scheme: Rationale and impacts. *Energy Policy* **2014**, *73*, 722–732. [[CrossRef](#)]
97. Zhang, X.; Liang, Y.; Yu, E.; Rao, R.; Xie, J. Review of electric vehicle policies in China: Content summary and effect analysis. *Renew. Sustain. Eng. Rev.* **2017**, *70*, 698–714. [[CrossRef](#)]
98. Lee, H.K.; Nam, K.H. An Overview: Current Control Technique for Propulsion Motor for EV. *Trans. Korean Inst. Power Electron.* **2016**, *21*, 388–395. [[CrossRef](#)]
99. Rajashekar, K. Present status and future trends in electric vehicle propulsion technologies. *IEEE J. Emerg. Sel. Top. Power Electron.* **2013**, *1*, 3–10. [[CrossRef](#)]
100. Sutikno, T.; Idris, N.R.N.; Jidin, A. A review of direct torque control of induction motors for sustainable reliability and energy efficient drives. *Renew. Sustain. Energy Rev.* **2014**, *32*, 548–558. [[CrossRef](#)]
101. Kumar, M.S.; Revankar, S.T. Development scheme and key technology of an electric vehicle: An overview. *Renew. Sustain. Energy Rev.* **2017**, *70*, 1266–1285. [[CrossRef](#)]
102. Ameid, T.; Menacer, A.; Talhaoui, H.; Azzoug, Y. Discrete wavelet transform and energy eigen value for rotor bars fault detection in variable speed field-oriented control of induction motor drive. *ISA Trans.* **2018**, *79*, 217–231. [[CrossRef](#)]
103. Chan, C.C. The state of the art of electric and hybrid vehicles. *Proc. IEEE* **2002**, *90*, 247–275. [[CrossRef](#)]
104. Hoand, L.H. Comparison of field-oriented control and direct torque control for induction motor drives. In Proceedings of the IEEE 34th IAS Annual Meeting Conference Record of the Industry Applications Conference, Phoenix, AZ, USA, 3–7 October 1999; pp. 1245–1252. [[CrossRef](#)]
105. Casadei, D.; Profumo, F.; Serra, G.; Tani, A. FOC and DTC: Two viable schemes for induction motors torque control. *IEEE Trans. Power Electron.* **2002**, *17*, 779–787. [[CrossRef](#)]
106. Singh, B.; Jain, P.; Mittal, A.P.; Gupta, J.R.P. Direct torque control: A practical approach to electric vehicle. *IEEE Power India Conf.* **2006**, *4*. [[CrossRef](#)]
107. Farasat, M.; Karaman, E. Speed sensorless electric vehicle propulsion system using hybrid FOC-DTC induction motor drive. In Proceedings of the International Conference on Electrical Machines and Systems (ICEMS), Beijing, China, 20–23 August 2011; pp. 1–5. [[CrossRef](#)]
108. Rehman, H.; Longya, X. Alternative energy vehicles drive system: Control. Flux and torque estimation and efficiency optimization. *IEEE Trans. Veh. Technol.* **2011**, *60*, 3625–3634. [[CrossRef](#)]
109. Singh, B.; Singh, S. State of art on permanent magnet brushless DC motor drives. *J. Power Electron.* **2009**, *9*, 1–17.
110. Chan, C.C. An overview of Electric Vehicle Technology. *Proc. IEEE* **1993**, *81*, 1202–1213. [[CrossRef](#)]
111. Chan, C.C.; Chau, K.T. *Modern Electric Vehicles Technology*; Oxford University Press: Oxford, UK, 2001; pp. 167–180.
112. Kim, T.; Lee, W.; Parsa, L.; Ehsani, M. Optimal power and torque control of a brushless DC (BLDC) motor/generator drive in electric and hybrid electric vehicles. In Proceedings of the IEEE Industry Applications Conference, Tampa, FL, USA, 8–12 October 2006; pp. 1276–1281. [[CrossRef](#)]
113. Gamazo-Real, J.C.; Vazquez-Sanchez, E.; Gomez-Gil, J. Position and speed control of brushless DC motors using sensorless techniques and application trends. *Sensors* **2010**, *10*, 6901–6947. [[CrossRef](#)] [[PubMed](#)]

114. Hubik, V.; Sveda, M.; Singule, V. On the Development of BLDC Motor Control Run-Up Algorithms for Aerospace Application. In Proceedings of the 13th Power Electronics and Motion Control Conference (EPE-PEMC2008), Poznan, Poland, 1–3 September 2008; pp. 1620–1624. [\[CrossRef\]](#)
115. Sundeep, S.; Singh, B. Robust Position Sensorless Technique for a PMBLDC Motor. *IEEE Trans. Power Electron.* **2018**, *33*, 6936–6945. [\[CrossRef\]](#)
116. Singh, S.; Singh, S. Position Sensorless Control for PMBLDC Motor Drive Using Digital Signal Processor. *J. Circuits Syst. Comput.* **2016**, *25*, 1650077. [\[CrossRef\]](#)
117. Kumar, M.; Singh, B.; Singh, B.P. DSP based sensorless control of permanent magnet brushless DC motor. *IETE J. Res.* **2003**, *49*, 269–275. [\[CrossRef\]](#)
118. Carpiuc, S.; Lazar, C. Modeling of synchronous electric machines for real-time simulation and automotive applications. *J. Frankl. Inst.* **2017**, *354*, 6258–6281. [\[CrossRef\]](#)
119. Finken, T.; Hombitzer, M.; Hameyer, K. Study and comparison of several permanent-magnet excited rotor types regarding their applicability in electric vehicles. In Proceedings of the 2010 Emobility-Electrical Power Train conference, Leipzig, Germany, 8–9 November 2010. [\[CrossRef\]](#)
120. Chaoui, H.; Khyamy, M.; Okoye, O. MTPA based operation point speed tracking for PMSM drives without explicit current regulation. *Electr. Power Syst. Res.* **2017**, *151*, 125–135. [\[CrossRef\]](#)
121. Boubaker, N.; Matt, D.; Enrici, P.; Nierlich, F.; Durand, G.; Orlandini, F.; Longère, X.; Aïgba, J.S. Study of eddy-current loss in the sleeves and Sm-Co magnets of a high-performance SMPM synchronous machine (10 kRPM, 60 kW). *Electr. Power Syst. Res.* **2017**, *142*, 20–28. [\[CrossRef\]](#)
122. Feng, G.; Lai, C.; Iyer, K.; Kar, N. Improved high-frequency voltage injection based permanent magnet temperature estimation for PMSM condition monitoring for EV applications. *IEEE Trans. Veh. Technol.* **2018**, *67*, 216–225. [\[CrossRef\]](#)
123. Lara, J.; Xu, J.; Chandra, A. Effects of rotor position error in the performance of field-oriented-controlled PMSM drives for electric vehicle traction applications. *IEEE Trans. Ind. Electron.* **2016**, *63*, 4738–4751. [\[CrossRef\]](#)
124. Fodorean, D.; Sarrazin, M.; Martis, C.; Anthonis, J.; van der Auweraer, H. Electromagnetic and structural analysis for a surface-mounted PMSM used for light-EV. *IEEE Trans. Ind. Electron.* **2016**, *52*, 2892–2899. [\[CrossRef\]](#)
125. Niu, F.; Wang, B.; Babel, A.; Li, K. Comparative evaluation of direct torque control strategies for permanent magnet synchronous machines. *IEEE Trans. Power Electron.* **2015**, *31*, 1408–1424. [\[CrossRef\]](#)
126. Hassan, A.; Shehata, E. High performance direct torque control schemes for an IPMSM drive. *Electr. Power Syst. Res.* **2012**, *89*, 171–182. [\[CrossRef\]](#)
127. Rocha-Osorio, C.M.; Solís-Chaves, J.; Casella, R.; Capovilla, C.; Azcue-Puma, J.; Sguarezi-Filho, A. GPRS/EGPRS standards applied to DTC of a DFIG using fuzzy PI controllers. *Int. J. Electr. Power Energy Syst.* **2017**, *93*, 365–373. [\[CrossRef\]](#)
128. Khooban, M.H.; Vafamand, N.; Niknam, T. T-S fuzzy model predictive speed control of electrical vehicles. *ISA Trans.* **2016**, *64*, 231–240. [\[CrossRef\]](#)
129. Niu, H.; Yu, J.; Yu, H.; Lin, C.; Zhao, L. Adaptive fuzzy output feedback and command filtering error compensation control for permanent magnet synchronous motors in electric vehicle drive systems. *J. Frankl. Inst.* **2017**, *354*, 6610–6629. [\[CrossRef\]](#)
130. Yu, J.; Shi, P.; Dong, W.; Lin, C. Reduced-order observer-based adaptive fuzzy tracking control for chaotic permanent magnet synchronous motors. *Neurocomputing* **2016**, *214*, 201–209. [\[CrossRef\]](#)
131. Pellegrino, G.; Armando, E.; Guglielmi, P. Optimal exploitation of the constant power region of IPM drives based on field oriented control. In Proceedings of the IEEE Industry Applications Conference, New Orleans, LA, USA, 23–27 September 2007; pp. 1335–1340. [\[CrossRef\]](#)
132. Chinchilla, M.; Arnaltes, S.; Burgos, J. Control of permanent-magnet generators applied to variable-speed wind energy system connected to the grid. *IEEE Trans. Energy Convers.* **2006**, *87*, 130–135. [\[CrossRef\]](#)
133. Lara, A. Chandra. Performance investigation of two novel HSFSI demodulation algorithms for encoderless FOC of PMSMs intended for EV propulsion. *IEEE Trans. Ind. Electron.* **2018**, *65*, 1074–1083. [\[CrossRef\]](#)
134. Tang, Z.; Akin, B. A new LMS algorithm based deadtime compensation method for PMSM FOC drives. *IEEE Trans. Ind. Appl.* **2018**, *54*, 6472–6484. [\[CrossRef\]](#)
135. Jung, S.; Hong, J.K. Nam Current minimizing torque control of the IPMSM using Ferrari’s method. *IEEE Trans. Power Electron.* **2013**, *28*, 5603–5617. [\[CrossRef\]](#)

136. Arias, A.; Ibarra, E.; Tarancho, E.; Grino, R.; Kortabarria, I.; Caum, J. Comprehensive high speed automotive SM-PMSM torque control stability analysis including novel control approach. *Int. J. Electr. Power Energy Syst.* **2019**, *109*, 423–433. [[CrossRef](#)]
137. Miranda, R.S.; Fernandes, E.M.; Jacobina, C.N.; Lima, A.M.N.; Oliveira, A.C.; Correa, M.B.R. Sensorless control of a PMSM synchronous motor at low speed. In Proceedings of the IECON 2006–32ND Annual Conference on IEEE Industrial Electronics, Paris, France, 6–10 November 2006. [[CrossRef](#)]
138. Monteiro, J.R.; Oliveira, A.A.; Aguiar, M.L.; Sanagiotti, E.R. Electromagnetic torque ripple and copper losses reduction in permanent magnet synchronous machines. *Eur. Trans. Electr. Power* **2012**, *22*, 627–644. [[CrossRef](#)]
139. Gan, C.; Wu, J.H.; Sun, Q.G.; Kong, W.B.; Li, H.Y.; HU, Y.H. A review on machine topologies and control techniques for low-noise switched reluctance motors in electric vehicle application. *IEEE Access* **2018**, *6*, 31430–31443. [[CrossRef](#)]
140. Jing, L.B.; Cheng, J. Research on torque ripple optimization of switched reluctance motor based on finite element method. *Prog. Electromagn. Res.* **2018**, *74*, 115–123. [[CrossRef](#)]
141. Millithaler, P.; Dupont, J.B.; Ouisse, M.; Sadoulet-Reboul, E.; Bouhaddi, N. Viscoelastic property tuning for reducing noise radiated by switched-reluctance machines. *J. Sound Vib.* **2017**, *407*, 191–208. [[CrossRef](#)]
142. Klein-Hessling, A.; Hofmann, A.; de Doncher, R.M. Direct instantaneous torque and force control: A control approach for switched reluctance machines. *IET Electr. Power Appl.* **2013**, *11*, 935–943. [[CrossRef](#)]
143. Shin, S.; Kawagoe, N.; Kosaka, T.; Matsui, N. Study on commutation control method for reducing noise and vibration in SRM. *IEEE Trans. Ind. Appl.* **2018**, *54*, 4415–4424. [[CrossRef](#)]
144. Hall, D.; Lutsey, N. *Emerging Best Practices for Electric Vehicle Charging Infrastructure*; The International Council on Clean Transportation (ICCT): Washington, DC, USA, 2017.
145. Dong, J.; Liu, C.; Lin, Z. Charging infrastructure planning for promoting battery electric vehicles: An activity-based approach using multiday travel data. *Transp. Res. Part C Emerg. Technol.* **2014**, *38*, 44–55. [[CrossRef](#)]
146. Sweda, T.; Klabjan, D. An agent-based decision support system for electric vehicle charging infrastructure deployment. In Proceedings of the 2011 IEEE Vehicle Power and Propulsion Conference, Chicago, IL, USA, 6–9 September 2011; pp. 1–5. [[CrossRef](#)]
147. Ghamami, M.; Nie, Y.; Zockaie, A. Planning charging infrastructure for plug-in electric vehicles in city centers. *Int. J. Sustain. Transp.* **2016**, *10*, 343–353. [[CrossRef](#)]
148. Liu, J. Electric vehicle charging infrastructure assignment and power grid impacts assessment in Beijing. *Energy Policy* **2012**, *51*, 544–557. [[CrossRef](#)]
149. Schroeder, A.; Traber, T. The economics of fast charging infrastructure for electric vehicles. *Energy Policy* **2012**, *43*, 136–144. [[CrossRef](#)]
150. Xi, X.; Sioshansi, R.; Marano, V. Simulation–optimization model for location of a public electric vehicle charging infrastructure. *Transp. Res. Part D Transp. Environ.* **2013**, *22*, 60–69. [[CrossRef](#)]
151. San Román, T.G.; Momber, I.; Abbad, M.R.; Miralles, A.S. Regulatory framework and business models for charging plug-in electric vehicles: Infrastructure, agents, and commercial relationships. *Energy Policy* **2011**, *39*, 6360–6375. [[CrossRef](#)]
152. Wang, B.; Hu, Y.; Zeng, F. A user cost and convenience oriented EV charging and discharging scheduling algorithm in V2G based microgrid. In Proceedings of the 2017 International Conference on Circuits, Devices and Systems (ICDDS), Chengdu, China, 5–8 September 2017; pp. 156–162. [[CrossRef](#)]
153. Chung, H.M.; Alinia, B.; Crespi, N.; Wen, C.K. An EV Charging Scheduling Mechanism to Maximize User Convenience and Cost Efficiency. *arXiv* **2016**, arXiv:1606.00998.
154. Teng, J.H.; Liao, S.H.; Wen, C.K. Design of a fully decentralized controlled electric vehicle charger for mitigating charging impact on power grids. *IEEE Trans. Ind. Appl.* **2016**, *53*, 1497–1505. [[CrossRef](#)]
155. Liao, S.H.; Teng, J.H.; Wen, C.K. Developing a smart charger for EVs’ charging impact mitigation. In Proceedings of the IEEE 2nd International Future Energy Electronics Conference (IFEEEC), Taipei, Taiwan, 1–4 November 2015; pp. 1–6. [[CrossRef](#)]
156. Dubarry, M.; Devie, A.; McKenzie, K. Durability and reliability of electric vehicle batteries under electric utility grid operations: Bidirectional charging impact analysis. *J. Power Sources* **2017**, *358*, 39–49. [[CrossRef](#)]

157. He, J.; Yang, H.; Tang, T.Q.; Huang, H.J. An optimal charging station location model with the consideration of electric vehicle's driving range. *Transp. Res. Part C Emerg. Technol.* **2018**, *86*, 641–654. [CrossRef]
158. Tang, M.; Gong, D.; Liu, S.; Lu, X. Finding key factors affecting the locations of EV charging Station: A simulation an anova approach. *Int. J. Simul. Model. (IJSIMM)* **2017**, *16*. [CrossRef]
159. Zhou, Y. The Overview of the EV Charging Station Regulation. In Proceedings of the 37th Chinese Control Conference (CCC), Wuhan, China, 25–27 July 2018; pp. 8969–8974. [CrossRef]
160. Guo, F.; Yang, J.; Lu, J. The battery charging station location problem: Impact of users' range anxiety and distance convenience. *Transp. Res. Part E Logist. Transp. Rev.* **2018**, *114*, 1–18. [CrossRef]
161. Thomas, C.S. US marginal electricity grid mixes and EV greenhouse gas emissions. *Int. J. Hydrog. Energy* **2012**, *37*, 19231–19240. [CrossRef]
162. Traut, E.; Hendrickson, C.; Klampfl, E.; Liu, Y.; Michalek, J.J. Optimal design and allocation of electrified vehicles and dedicated charging infrastructure for minimum life cycle greenhouse gas emissions and cost. *Energy Policy* **2012**, *51*, 524–534. [CrossRef]
163. Kim, J.D.; Rahimi, M. Future energy loads for a large-scale adoption of electric vehicles in the city of Los Angeles: Impacts on greenhouse gas (GHG) emissions. *Energy Policy* **2014**, *73*, 620–630. [CrossRef]
164. Nienhueser, I.A.; Qiu, Y. Economic and environmental impacts of providing renewable energy for electric vehicle charging—A choice experiment study. *Appl. Energy* **2016**, *180*, 256–268. [CrossRef]
165. Jin, C.; Sheng, X.; Ghosh, P. Optimized electric vehicle charging with intermittent renewable energy sources. *IEEE J. Sel. Top. Signal Process.* **2014**, *8*, 1063–1072. [CrossRef]
166. Babic, J.; Carvalho, A.; Ketter, W.; Podobnik, V. Modelling electric vehicle owners' willingness to pay for a charging service. In Proceedings of the Erasmus Energy Forum, Energy Informatics & Management, Rotterdam, The Netherlands, 18–19 May 2016; pp. 1–8.
167. Liu, X.; Yang, Y.; He, Y.; Zhang, J.; Zheng, X.; Ma, M.; Zeng, G. A new dynamic SOH estimation of lead-acid battery for substation application. *Int. J. Energy Res.* **2017**, *41*, 579–592. [CrossRef]
168. Cacciato, M.; Nobile, G.; Scarcella, G.; Scelba, G. Real-time model-based estimation of SOC and SOH for energy storage systems. *IEEE Trans. Power Electron.* **2016**, *32*, 794–803. [CrossRef]
169. Wang, Y.; Chen, Z.; Zhang, C. On-line remaining energy prediction: A case study in embedded battery management system. *Appl. Energy* **2017**, *194*, 688–695. [CrossRef]
170. Melo, D.F.R.; Trippe, A.; Gooi, H.B.; Massier, T. Robust electric vehicle aggregation for ancillary service provision considering battery aging. *IEEE Trans. Smart Grid* **2016**, *9*, 1728–1738. [CrossRef]
171. Burnham, A.; Dufek, E.J.; Stephens, T.; Francfort, J.; Michelbacher, C.; Carlson, R.B.; Scoffield, D. Enabling fast charging—Infrastructure and economic considerations. *J. Power Sources* **2017**, *367*, 237–249. [CrossRef]
172. Tian, Z.; Jung, T.; Wang, Y.; Zhang, F.; Tu, L.; Xu, C.; Li, X.Y. Real-time charging station recommendation system for electric-vehicle taxis. *IEEE Trans. Intell. Transp. Syst.* **2016**, *17*, 3098–3109. [CrossRef]
173. Li, M.; Wu, X.K.; He, X.Z.; Yu, G.Z.; Wang, Y.P. An Eco-driving system for electric vehicles with signal control under V2X environment. *Transp. Res. Part C Emerg. Technol.* **2018**, *93*, 335–350. [CrossRef]
174. Zhu, B.; Wu, D.; Zheng, M.Y. Electric vehicle energy predictive optimal control by V2I communication. *Adv. Mech. Eng.* **2019**, *11*, 1687814018821523. [CrossRef]
175. Yilmaz, M.; Krein, P.T. Review of the impact of vehicle-to-grid technologies on distribution systems and utility interfaces. *IEEE Trans. Power Electron.* **2013**, *28*, 5673–5689. [CrossRef]
176. Habib, S.; Kamran, M.; Rashid, U. Impact analysis of vehicle-to-grid technology and charging strategies of electric vehicles on distribution networks—A review. *J. Power Sources* **2015**, *277*, 205–214. [CrossRef]
177. Sewalkar, P.; Seitz, J. Vehicle-to-pedestrian communication for vulnerable road users: Survey, design considerations, and challenges. *Sensors* **2019**, *19*, 358. [CrossRef]
178. Alnasser, A.; Sun, H.J.; Jian, J. Cyber security challenges and solutions for V2X communications: A survey. *Comput. Netw.* **2019**, *151*, 52–67. [CrossRef]
179. Wang, J.; Shao, Y.M.; Ge, Y.M. A Survey of Vehicle to Everything (V2X) Testing. *Sensors* **2019**, *19*, 334. [CrossRef]
180. Tong, W.; Hussain, A.; Bo, W.X. Artificial Intelligence for Vehicle-to-Everything: A Survey. *IEEE Access* **2019**, *7*, 10823–10843. [CrossRef]
181. Helmer, E.; Marx, P. Electric cars: Technical Characteristics and Environmental Impacts. *Environ. Sci. Eur.* **2012**. Available online: <http://www.enveurope.com/content/24/1/14> (accessed on 26 April 2012). [CrossRef]

182. Guo, C.L.; Chan, C.C. Whole-system thinking, development control, key barriers and promotion mechanism for EV development. *J. Mod. Power Syst. Clean Energy* **2015**, *3*, 160–169. [[CrossRef](#)]
183. Deng, D. Li-ion batteries: Basic, progress, and challenges. *Energy Sci. Eng.* **2015**, *3*, 385–418. [[CrossRef](#)]



© 2019 by the authors. Licensee MDPI, Basel, Switzerland. This article is an open access article distributed under the terms and conditions of the Creative Commons Attribution (CC BY) license (<http://creativecommons.org/licenses/by/4.0/>).