

NATL INST OF STAND & TECH



A11107 245570



NBS
PUBLICATIONS

NBS SPECIAL PUBLICATION **610**

U.S. DEPARTMENT OF COMMERCE / National Bureau of Standards

Telecommunication Technologies, Networking and Libraries

QC

100

.U57

No. 610

1981

c. 2

NATIONAL BUREAU OF STANDARDS

The National Bureau of Standards¹ was established by an act of Congress on March 3, 1901. The Bureau's overall goal is to strengthen and advance the Nation's science and technology and facilitate their effective application for public benefit. To this end, the Bureau conducts research and provides: (1) a basis for the Nation's physical measurement system, (2) scientific and technological services for industry and government, (3) a technical basis for equity in trade, and (4) technical services to promote public safety. The Bureau's technical work is performed by the National Measurement Laboratory, the National Engineering Laboratory, and the Institute for Computer Sciences and Technology.

THE NATIONAL MEASUREMENT LABORATORY provides the national system of physical and chemical and materials measurement; coordinates the system with measurement systems of other nations and furnishes essential services leading to accurate and uniform physical and chemical measurement throughout the Nation's scientific community, industry, and commerce; conducts materials research leading to improved methods of measurement, standards, and data on the properties of materials needed by industry, commerce, educational institutions, and Government; provides advisory and research services to other Government agencies; develops, produces, and distributes Standard Reference Materials; and provides calibration services. The Laboratory consists of the following centers:

Absolute Physical Quantities² — Radiation Research — Thermodynamics and Molecular Science — Analytical Chemistry — Materials Science.

THE NATIONAL ENGINEERING LABORATORY provides technology and technical services to the public and private sectors to address national needs and to solve national problems; conducts research in engineering and applied science in support of these efforts; builds and maintains competence in the necessary disciplines required to carry out this research and technical service; develops engineering data and measurement capabilities; provides engineering measurement traceability services; develops test methods and proposes engineering standards and code changes; develops and proposes new engineering practices; and develops and improves mechanisms to transfer results of its research to the ultimate user. The Laboratory consists of the following centers:

Applied Mathematics — Electronics and Electrical Engineering² — Mechanical Engineering and Process Technology² — Building Technology — Fire Research — Consumer Product Technology — Field Methods.

THE INSTITUTE FOR COMPUTER SCIENCES AND TECHNOLOGY conducts research and provides scientific and technical services to aid Federal agencies in the selection, acquisition, application, and use of computer technology to improve effectiveness and economy in Government operations in accordance with Public Law 89-306 (40 U.S.C., 759), relevant Executive Orders, and other directives; carries out this mission by managing the Federal Information Processing Standards Program, developing Federal ADP standards guidelines, and managing Federal participation in ADP voluntary standardization activities; provides scientific and technological advisory services and assistance to Federal agencies; and provides the technical foundation for computer-related policies of the Federal Government. The Institute consists of the following centers:

Programming Science and Technology — Computer Systems Engineering.

¹Headquarters and Laboratories at Gaithersburg, MD, unless otherwise noted; mailing address Washington, DC 20234.

²Some divisions within the center are located at Boulder, CO 80303.

NATIONAL BUREAU
OF STANDARDS
LIBRARY
NOV 18 1981

Telecommunication Technologies, Networking and Libraries

Proceedings of a Conference on Telecommunication
Technologies, Networking and Libraries,
Held at the National Bureau of Standards,
Gaithersburg, MD, June 3, 1977

Edited by:

Nancy H. Knight

10608 Fiesta Road
Fairfax, VA 22032

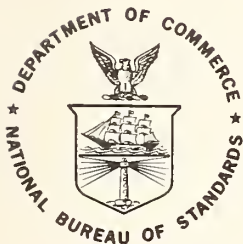

U.S. DEPARTMENT OF COMMERCE, Malcolm Baldrige, Secretary
NATIONAL BUREAU OF STANDARDS, Ernest Ambler, Director

Issued December 1981

Library of Congress Catalog Card Number: 81-600069

NATIONAL BUREAU OF STANDARDS SPECIAL PUBLICATION 610
Nat. Bur. Stand. (U.S.), Spec. Publ. 610, 90 pages (Dec. 1981)
CODEN: XNBSAV

U.S. GOVERNMENT PRINTING OFFICE
WASHINGTON: 1981

For sale by the Superintendent of Documents, U.S. Government Printing Office, Washington, D C 20402
Price \$4.75
(Add 25 percent for other than U.S. mailing)

Introduction

On June 3, 1977, the National Bureau of Standards Library and Information Services Division sponsored a one-day Conference on Telecommunication Technologies, Networking, and Libraries. The purpose of the Conference was to provide an overview of some of the major telecommunication developments likely to impact libraries and information centers in the near future.

The idea for the Conference grew out of a series of discussions among librarians and information scientists who became interested in the use of satellites for transmitting library information and for training of library staff and users. They were concerned about the problems facing libraries and information centers: increased operating costs, budgets eroded by inflation, storage and shelving space decreased by the information explosion, the need to retrieve information faster than ever, and the need to train staff and keep abreast of new technologies. They felt telecommunication technologies and techniques and the emerging regional and national networks offered promise of relief from some of these problems.

Experts from many areas of the telecommunications field addressed the Conference. Edited versions of their presentations are included in these Proceedings. It should be noted that the presentations were delivered in an informal, workshop atmosphere, and therefore are not intended to be definitive papers.

Also included in these Proceedings is a paper, entitled "Videodiscs-- A Fast Retrieval, Mass Storage Media for Libraries." Although it was not delivered at the Conference, it is included at the request of many of the Conference attendees.

For the convenience of the reader a Glossary of terms has been compiled and precedes the text of the papers. Terms defined in the Glossary are underlined the first time they appear in the text.

Patricia Wilson Berger
Chief, Library and Information
Services Division
National Bureau of Standards

September 1981

Abstract

The conference provided an overview of current and developing technologies for digital transmission of image data that are likely to have an impact on the operations of libraries and information centers or provide support for information networking. Technologies reviewed include slow-scan television, teleconferencing, satellite telecommunications, telefacsimile, microimage transmission, holography, and videodisc. Other papers discuss technology and standards development for computer network interconnection through hardware and software, particularly packet-switched networks; computer network protocols for library and information service applications; the structure of a national bibliographic telecommunications network; and the major policy issues involved in the regulation or deregulation of the common communications carriers industry.

Key Words: computer network interconnection; computer network protocol; digital transmission of information; electronic message transmission; image transmission; information networks; national bibliographic network; satellite communications; slow scan television; telecommunications policy; teleconferencing; videodiscs

Table of Contents

Introduction-----	iii
Abstract-----	iv
Table of Contents-----	v
Glossary-----	vii
Network Architecture	
Ira W. Cotton-----	1
Competition vs. Monopoly in Telecommunications	
Lawrence F. Darby-----	9
Competition vs. Monopoly in Telecommunications	
R. B. Johnson-----	13
The National Bibliographic Telecommunications Network	
Henriette D. Avram-----	17
Progress in the Development of Computer Network Protocols for Library and Information Service Applications	
John L. Little-----	28
Telecommunications and the Expansion of Information Services	
Stuart L. Meyer-----	39
Uses of Teleconferencing in Crisis and Warning Situations	
Thomas G. Belden-----	53
Interactive Telecommunications via Satellite	
Earl Henderson-----	61
Telecommunication R&D--Implications and Support for Library Programs	
Richard W. H. Lee-----	66
Videodiscs--A Fast Retrieval, Mass Storage Media for Libraries	
Robert Warnar, Madeline Henderson, and Patricia Berger-----	74

DISCLAIMER

Opinions expressed in non-NBS papers are those of the authors, and not necessarily those of the National Bureau of Standards. Non-NBS authors are solely responsible for the content and quality of their submissions.

The mention of trade names in the volume does not constitute an endorsement or recommendation by the National Bureau of Standards.

GLOSSARY

- ASCII - (American National Standard Code for Information Interchange, X3.4-1968). The standard code, using a coded character set consisting of 7-bit coded characters (8 bits including parity check), used for information interchange among data processing systems, communications systems, and associated equipment. The ASCII set consists of control characters and graphic characters.
- BIT - A unit of information content. Contraction of "binary digit," a bit is the smallest unit of information in a binary system of notation. It is the choice between two possible states, usually designated one and zero.
- BLOCK - A group of characters or digits transmitted as a unit, over which a coding procedure is usually applied for synchronization or error control purposes. Syn: Frame, Transmission Block. See also: PACKET.
- BROADCAST - The simultaneous dissemination of information to a number of stations.
- BUFFER - (1) A routine or storage used to compensate for a difference in rate of flow of data, or time of occurrence of events, when transmitting data from one device to another. (2) An area of storage that is temporarily reserved for use in performing an input/output operation, into which data is read or from which data is written.
- BUS - A circuit or path over which data or power is transmitted, usually lines that connect locations or a single line that acts as a common connection among a number of locations.
- BYTE - (1) A sequence of adjacent binary digits operated upon as a unit and usually shorter than a computer word. (2) The representation of a character, a common representation being 8 binary digits equal 1 byte, which equals 1 character.
- CARRIER SYSTEM - A means of obtaining a number of channels over a single path by modulating each channel on a different frequency and demodulating at the receiving point to restore the signals to their original form.
- CHARACTER - The actual or coded representation of a letter, digit, or other symbol. A character is often in the form of a spatial arrangement of adjacent or connected strokes.
- CIA - Central Intelligence Agency.

CIRCUIT SWITCHING - A method of communications, where an electrical connection between calling and called stations is established on demand for the exclusive use of the circuit until the connection is released.

CODE - (1) A set of unambiguous symbols and rules specifying the way in which data may be represented. Synonymous with coding scheme. (2) In telecommunications, a system of rules and conventions according to which the signals representing data can be formed, transmitted, received, and processed. (3) In data processing, to represent data or a computer program in a symbolic form that can be accepted by a data processor. (4) To write a routine.

COMMAND - (1) A control signal. (2) Loosely, an instruction in machine language. (3) Loosely, a mathematical or logical operator. (4) A request from a terminal for the execution of a particular program, called a command processor.

COMMON CARRIER - In telecommunications, a public utility company that is recognized by an appropriate regulatory agency as having the authority and responsibility to furnish communication services to the general public.

CONCENTRATOR - A device which connects a number of circuits which are not all used at once to a smaller group of circuits for economical transmission. A telephone concentrator achieves the reduction with a circuit-switching mechanism. A data concentrator buffers incoming data and retransmits it over appropriate output lines.

CRT - Cathode Ray Tube.

DATA COMMUNICATION - The interchange of data messages from one point to another over communications channels.

DATA COMMUNICATION EQUIPMENT - The equipment that provides the functions required to establish, maintain and terminate a connection, the signal conversion and coding required for communications between Data Terminal Equipment and data Circuit. The DCE may or may not be an integral part of the Data Terminal Equipment or of a computer, e.g., a Modem. Abbr: DCE.

DCI - Director, Central Intelligence.

EBCDIC - Extended binary coded decimal interchange code.

ECHO CHECK - A method of checking the accuracy of transmission of data in which the received data are returned to the sending end for comparison with the original data.

GATEWAY - An interface device between two networks.

HEADER LABEL - A file or data set label that precedes the data records on a unit of recording media.

HEADER RECORD - A record containing common, constant, or identifying information for a group of records that follows.

HOST COMPUTER - A computer attached to a network providing primarily services such as computation, data base access or special programs and programming languages.

INTERACTIVE - Pertaining to an application in which each entry elicits a response, as in an inquiry system. An interactive system may also be conversational, implying a continuous dialog between the user and the system.

INTERFACE - (1) A shared boundary defined by common physical interconnection characteristics, signal characteristics, and meanings of interchanged signals. (2) A device or equipment making possible interoperation between two systems, e.g., a hardware component or common storage register. (3) A shared logical boundary between two software components.

LINK - The logical association of two or more data communications stations interconnected by the same data communications circuit for the purpose of transmitting and receiving data using prescribed data communication control procedures.

MARC - An abbreviation for Machine Readable Cataloging.

MODE - A method of operation; for example, the binary mode; the interpretive mode.

MODEM - Modulator-demodulator. A device that modulates and demodulates digital signals so that they may be transmitted over an analog transmission medium. Syn: Data Set.

MULTIPLEX - To interleave or simultaneously transmit two or more messages on a single channel.

MULTIPLEXER - A hardware device that allows handling of multiple signals over a single channel.

MULTIPOINT NETWORK - A configuration in which more than two terminal installations are connected.

NBS - National Bureau of Standards.

NCLIS - National Commission on Libraries and Information Science.

NSA - National Security Agency

NTAG - Network Technical Architecture Group (Library of Congress).

NODE - (1) An end point of any branch of a network, or a junction common to two or more branches of a network. (2) Any station, terminal, terminal installation, communications computer, or communications computer installation in a computer network.

PACKET - A group of binary digits including data and control elements which is switched and transmitted as a composite whole. The data and control elements and possibly control information are arranged in a specified format.

PACKET SWITCHING - A data transmission process, utilizing addressed packets, whereby a channel is occupied only for the duration of transmission of the packet. Note: In certain data communication networks, the data may be formatted into a packet or divided and then formatted into a number of packets (either by the data terminal equipment or by equipment within the network) for transmission and multiplexing purposes.

POINT-TO-POINT NETWORK - A network configuration in which a connection is established between two, and only two, terminal installations.

PROTOCOL - A formal set of conventions governing the format and relative timing of message exchange between two communicating processes.

SINK - (1) The point of usage of data in a network. (2) A data terminal installation that receives and processes data from a connected channel.

STAR NETWORK - A computer network with peripheral nodes all connected to one or more computers at a centrally located facility.

STORE AND FORWARD - Pertaining to communications where a message is received, stored and forwarded (as in message and packet switching).

STRING - A linear sequence of entities such as characters or physical elements. For example, a book title is a string of alphabetic characters.

Network Architecture

by

Ira W. Cotton

I'm going to talk about computer network interconnection. Fortunately, I have written a technical note on the subject--NBS Special Publication 500-6 (see reference at end of paper). This presentation is essentially the expurgated version of that document.

I'm going to talk about network interconnection in a fairly broad sense. I guess you could view this as a tutorial. We'll be reviewing some of the standards developments and taking a look at what's happening today in a very dynamic and rapidly changing area. I work in the Computer Networking Section at the National Bureau of Standards. We take a fairly expansive view of what a network is. We consider a network to be any system that involves both computers and communications, be it a multi-computer, long-distance network like the ARPANET or simply a single user terminal over a communications line to a time-sharing system.

The current data communications networking environment is characterized by unprecedented innovation and growth. Customer costs have been dropping over the past few years. The pace of technological innovation has been quite rapid. There has been increased competition for services, at least in this country, where the very specific policies of the Federal Communications Commission have been designed to foster additional competition for communications services. New vendors, such as TELENET, have come into the market. Other vendors, such as PCI and DATRAN, have entered the market and then left the market. We're dealing with a highly competitive area, but one in which the regulators apparently are prepared to see companies fail as well as succeed.

We are now in the stage of developing a new set of standards--a new generation, if you will--specifically designed for living in an increasingly digital world. In the past, we were faced with trying to carry digital information, computer information, over a voice telephone network which really wasn't suited for it. Now, we are seeing plant and equipment being installed for digital communications. We are faced with the prospect of exactly the opposite problem--of carrying digitized speech over a network designed for computer traffic. We discovered that a new set of standards would be more appropriate to handle this type of system. The impact of some of the most recent developments is not fully understood. The marketplace is still restructuring. The Congress of the United States is reexamining the total communications policy for this country, and there are a lot of open issues. The dust hasn't settled on some of these changes. We're in a transitional

At the time of the Conference, Dr. Cotton was a Division Chief in the Institute for Computer Sciences and Technology, National Bureau of Standards. He is now a Senior Associate of Booz, Allen, and Hamilton.

stage. We have new services being installed and new standards being designed. This is one of the few areas where we really are developing the standards in advance of installation of all the equipment in the hope that nonstandard systems won't be installed and vendors won't claim that they've already installed systems and it's too costly to convert to the standards. We are trying to prepare the standards in anticipation of the requirements in order to achieve broad compatibility.

I'll survey four types of interconnections this morning. They are circuit switching to the phone system interconnecting with packet switch networks (PSN); star networks--really host computers connected to packet switch networks; simple terminals connected to packet switch networks; and the interconnection of the packet switch networks themselves. We'll focus on packet switch systems because they are the most advanced technologically, and much of what applies for the interconnections in these areas would also apply to the simpler message switch systems. By considering the most complex case we'll have considered the simpler cases as well.

It's important to recognize that when we talk about interconnection, we're really talking about interfaces. An interface needs to be described at a number of levels. We will consider each of these levels independently. There are physical or mechanical characteristics of an interface. There are electrical characteristics, such as the variations of signal rise times and durations--engineering kinds of considerations. There are logical aspects--what a particular control lead means or what the significance of control characters are when they are passed across the interface. And finally there are procedural specifications--a set of control leads or a number of control characters. If the logical aspects of the interface are viewed as the syntax and the procedural specifications as a form of semantics, then we can look at that as a language. The procedural specifications tell us how to create meaning out of the language, how to form sentences, how to form instruction sequences. Generally, the logical and procedural aspects are collectively referred to as protocol.

Every interface has certain functional requirements. They all must have some means of addressing, except in the very simplest case of a point-to-point connection where you're simply talking to whoever is at the end of the line. In general, we are dealing with shared communications facilities and there has to be a way to identify the recipient of a particular message. We need to provide for signaling--some way of distinguishing control information from data. There are a variety of in-band and out-of-band techniques for doing that. We need to provide for flow control. Flow control refers to mechanisms for controlling the rate of data exchange between two points to prevent overload. Since we are dealing with communications facilities with finite capacities, there is only a limited amount of bandwidth available; there is only a limited amount of buffer space available. Yet we're dealing with signal generators--terminals and host computers--which might, if uncontrolled, put more data into the communications system than it has capacity to handle. That would result in data being lost, or perhaps congestion in

the communications system itself, resulting in intolerable delays. So we need a means of throttling the input from the various data sources. We also need flow control for systems where speed conversion is provided. We may have a high speed terminal trying to exchange data with a low speed terminal; we need a means of throttling the input from the high speed terminal so that the low speed terminal isn't saturated. We certainly need a means of error control, since we haven't devised perfect communication systems that are error free. We need a way of detecting errors and we need a way of recovering from errors. In most data communication systems, we recover by simply retransmitting the data that was discovered to be in error. But error control is much more complicated than simply detecting errors and retransmitting them. We need a way of detecting duplicates. For example, in store and forward systems a message might be delayed in transit so that we think it's been lost; but when we transmit it a second time, two messages arrive. We need a way to recover from catastrophic errors, from link failures. This is perhaps the area least well addressed in system design and in the design of protocols. It is very difficult to prove that a scheme satisfies all of the possible error conditions and is robust enough to recover. You know--we think we have a pretty good design and we implement it, and discover that it works great 99 out of 100 times and on the 100th time, something occurs that we didn't anticipate or on the 1000th time or on the 10,000th time. When you have systems that are shared by many hundreds of users and that are used day in and day out at very high data rates, even with a very low incidence of error you very rapidly experience all the possible error conditions. Typically, we are constantly fixing these problems in the field rather than testing them in the laboratory beforehand so that we know they are going to be handled properly.

The first type of interconnection is connection of the phone system--the switched voice telephone network--with packet networks. What I really want to point out here is that the voice network is still going to be used for various aspects of a packet switched system. It's going to be used for access to the switching nodes so that a user in a library or in an office with a terminal is typically going to gain access to the packet network using a modem, by dialing the phone number of the switch, and having the data carried in analog form over the telephone system to the switch. I don't see this being replaced for many, many years. We are very unlikely to have wide enough availability of digital service to change this situation. So if you have a terminal and you expect to be using a packet network, you can expect to be dialing it up for the foreseeable future.

Now the packet networks that are in existence today, by and large, still use internode lines provided by the telephone system--analog lines with modems and so forth. However, as wide-band digital service becomes available between major population centers, we can expect to see the trunk lines between the switching centers increasingly changed from analog circuits to digital circuits, and we'll perhaps see the satellite links used as well within the networks. These types of lines are more efficient, less error-prone, and offer many advantages to the packet

carriers. The last point there--the question of integrated data networks--is raised to indicate that the possibility exists for engineering systems that provide integrated or hybrid data networks capable of efficiently transporting both voice and message traffic.

Another approach is to engineer a special host interface--special in the sense that it's optimized for the characteristic of each type of host computer. It would be a channel interface of some kind, a very high-speed interface that is compatible with the architecture of the particular host computer. So essentially we need a new design for each type of host computer, which will take full advantage of the network capabilities, integrated into the design of the host operating systems. We're talking about writing new drivers and new control modules for the host. We're talking about a new access method for those of you familiar with that terminology, or a new symbiant, for those of you who live in the Univac world, or a multiplexing discipline. The problem is that the mainframe manufacturers haven't shown much interest in participating in these designs or in supporting the software after it has been written. This was the approach that was taken by the ARPA Network where the price of admission was engineering a host interface. But most of the costs were underwritten by ARPA and most of the work was done by graduate students looking for degree work. That's cheap labor and someone else is paying for it anyway, but it still caused all kinds of problems. So it's probably the worst of all worlds, especially when you consider the possibility of a standard type host interface based on a communications interface rather than a channel interface. An alternative would be to take existing standards at other levels and build up a common interface to packet networks which would appear identical at the network and to each of the hosts. There is some additional software development required to support the new control level that is required--we'll talk about that level in just a minute--but it's not as great as engineering an entirely new interface. It's standard and, hopefully, will be widely implemented and widely supported by the manufacturers and, in addition, it's especially engineered to take advantage of all the capabilities of the network.

This approach appears to offer the best long term solution, and consequently led to the development of the widely publicized X.25 standard which was recently adopted by the CCITT, the Consultative Committee on International Telegraphy and Telephony. This is an international organization, which is part of the International Telecommunications Union. The United States belongs to it by treaty. In most parts of the world, the recommendations that this organization adopts are precisely what the carrier organizations provide, since the carrier organizations in most parts of the world are government monopolies. You find countries being quite rigid about not offering a service if the CCITT hasn't standardized it. On the other hand, they try very hard to offer all the features that the CCITT does adopt. In this country, adoption of CCITT standards is much more voluntary, but those carriers that are considering interconnecting with international organizations certainly try very hard to adopt the standards.

Recommendation X.25 is an international standard interface to connect host computers to public packet switching networks. It is a multilevel interface based on other standards which have already been adopted, supporting a service called "virtual circuit" service, which is essentially intended to replace private circuit switch networks. What a host had in the past was a means of dialing a connection to a distant location and then having that connection remain in effect for the duration of the conversation. That's the kind of service that is trying to be provided here. There is a call establishment phase where you would go through the logical equivalent of setting up a call, then you go into a data transfer phase, and pump data into the packet network. The packet network assumes total responsibility for internal processing capabilities. What we are talking about here are teletypes and teletype-compatible terminals which don't have any internal processing capabilities. You strike a key and a character is sent immediately. There's no internal buffering, and there's no internal formatting. These terminals place fairly heavy support demands on any network that wants to let them connect directly to the network.

Some networks have taken the approach that only intelligent devices are going to be connected to the switches--The MERIT Network in Michigan, for example. If a simple terminal wants to access a remote host, it first has to go through its local host and make subroutine calls on processes which actually communicate through the network. It reduces the requirements on the network, but users pay double. You pay a fee to the local computer and you pay a fee to the remote computer, so it's a much more expensive approach for the users.

Therefore, networks have generally taken the approach that there's a market out there to support simple terminals directly, and they're going to provide those facilities in the network. What it really means is providing the equivalent of a small host computer right inside the switch which provides the support requirements to the terminals and acts as a surrogate host for them in communicating through the network. One of the things we must provide for simple terminals is a means of buffering, particularly for speed conversion. We may have a computer system transmitting into the network in burst mode at a higher data rate than the terminal itself operates, which might be limited to 10, 15, or 30 characters per second or slightly higher, but not much higher. This means we have a low speed device connected to a high speed network; we need buffering and flow control so as not to lose data from the terminal and not to overload the terminal on output. Another thing we need is a way of permitting the terminal to signal. What can you do from a simple terminal? All you can do is type keys. So, all the signaling must be done in character sequences typed by the operator. We must set up a language for terminal operators to express their requirements, to indicate the destination they wish to be connected to in order to recover from error conditions, and to indicate any other services they might like to access. Additional services that might be provided could include code conversion, for example. There are at least two major families of terminals, the ASCII family and the IBM EBCDIC family which uses an 8-bit code. It's entirely possible for a network to

provide a code translation facility between those kinds of terminals to allow them to interwork. That can be a very valuable service, although it does require resources in the network to provide it. We refer to the realization of these functions in the network as a packet assembler/disassembler since its function is to accept strings of individual characters from simple terminals and assemble them into packets which are sent through the network. One way to reduce communications costs is to try to fill these packets as heavily as possible. So, rather than strike a key and send a single character as a packet, we devise control strategies where we type in an entire line and only transmit a packet when a carriage return is struck, for example.

One alternative for providing this pad or packet assembler/disassembler function is to use the host computer as I indicated. Another is to use an intelligent concentrator, essentially a minicomputer, which is connected to the network and has all the capabilities of a host computer, but doesn't necessarily have to be provided by the carrier itself. A third party could go into the business of providing terminal support. In this case, the third party would buy a minicomputer, connect to the packet network, and advertise to customers in its geographic area that by making a local call to them, customers can gain access to the network. Carrier organizations could also take this approach. Finally, we could expand the switch itself. This approach was taken by the ARPA Network. The TIP, or terminal interface message processor, is an IMP, or interface message processor, that was expanded by adding a terminal multiplexer and additional software to pretend to be a host computer. Thus, we can expand the switch and permit terminals to dial directly to it.

The approach taken within the CCITT is to define the service characteristics of the packet assembler/disassembler. There are two sets of standards. On one side is a character mode standard that describes how simple terminals talk to this pad service. It is worded in terms of ASCII character strings and there is a command response repertoire that lets users express their desires. On the other side, there are additional packet formats, since there are parameter setting controls and so forth that have to be provided. This looks very much like a special kind of fourth level protocol to permit host computers to control the actions of the terminal. For example, one of the facilities that was built into the provisional standard at this level permits a host computer to shut off echoing so that a terminal can log on to a host and type in a string that says it wants to gain access; the host computer echoes back, please enter your password, and then shuts off echoing so that the password doesn't get displayed or typed on the user terminal; then it can turn echoing back on again. We need a way for commands of that type to be conveyed and the way they are conveyed is with new packets. A recommendation for the two parts of this approach was provisionally adopted by the CCITT a month or so ago; it will be implemented by a number of networks worldwide and, ultimately, I'm sure, be finally adopted.

The final area that we'll talk about is the interconnection of networks. Fifty or 75 years ago, we were faced with a situation where people were implementing telephone networks worldwide in very non-standard ways and it was virtually impossible to interconnect. It was difficult enough to make long-distance calls in this country with the hundreds of different independent telephone companies, each with its own internal signaling scheme and so forth, and international calls were extremely difficult to place. That situation was the motivation for much of the work of the CCITT. Well, really, international telegraphy was the original motivation and the same principles were applied to telephony. The situation a couple of years ago for data communications was every bit as bad as it was in telephony 50 or 75 years ago. There were just no standards and no way of placing international data calls, or at least of having the data understood. I think that if anyone were going to award the standard of the year award for 1976, it would have to go to X.25, since it's really going to lead to true international compatibility and full worldwide interconnection between the national packet carriers. We already have interconnection between Canada and the United States. We will shortly, if we don't yet, have interconnection between the United States and Britain, and the United States and France. Within a very few years, all of the major industrialized nations are going to have national public data networks with gateways to the data networks in other countries. Multinational corporations and international services will be routinely using these networks for international services. Just as there were a variety of ways of connecting host computers to packet networks, there are a variety of ways of interconnecting the packet networks themselves through a common host, a common switching node, or a device sitting between them--an internode device or a set of standards between the switching nodes.

The first two methods are very unlikely to be accepted. They have been used in various research projects. I know of a number of cases where networks have been interconnected through a common host without anyone knowing about it. I believe that TYMNET and ARPANET were connected through a common host on the West Coast. TELENET and ARPANET were connected through hosts. Most people tried to keep it quiet for various regulatory reasons. Common switching nodes are fairly unlikely. There are control problems. Who controls the nodes? Which network controls the switching node? Thus, the approach that is being taken is a compatible gateway where you set up a set of interface packets that networks use to exchange data internationally. There might be a new fourth level protocol for things like accounting, control messages between networks, and so forth. We don't yet have a comprehensive recommendation in this area, but work is proceeding quite actively and, as I indicated before, the packet networks are going ahead with interconnection and I'm sure that a common standard will result shortly.

What can we conclude? First of all, there is a very high demand for all types of interconnections. There is a demand for service. There is a demand for diversity of service. There is a demand for universality of service. If there is a service available, customers

don't want to be told that they can't gain access to it because they don't happen to live in the right place or because there is no way to access that service through the network to which they are currently connected. I work for the National Bureau of Standards. I have to believe that standards are the only workable approach to solving this kind of problem. As I indicated earlier, I don't think we're too late in this area--people cannot claim that they've made too large an investment in nonstandard implementations--and I don't think we're too early either. Nor do I think we're stifling innovation. I think this is a model area for demonstrating the introduction of standards at precisely the right timeframe, and we're making good progress toward that goal. There are a lot of people taking potshots at some of the standards that have been developed, and rightly so. They were developed somewhat hurriedly. There is some polishing that remains to be done, but I think that the basic structure is fundamentally sound. We have made significant progress and, as I indicated, within the next few years there will be more. Right now you can pick up a telephone in Washington, and you don't have to go through an operator to dial much of Western Europe. We have direct dialing to many parts of the world. You know--great, your kid can pick up the phone and dial London--it's not a total blessing, but I think the same kind of very easy and convenient access to services abroad and from overseas to services in this country will be routine. You won't even think about it. We are going to have very high quality, widely available standard services on an international basis, and I think that's a real triumph for the people who have been working in this area.

Reference: Cotton, Ira W. Computer Network Interconnection: Problems and Prospects. Washington, U.S. National Bureau of Standards; for sale by the Supt. of Docs., U.S. Govt. Print. Off., 1977. (NBS Special Publication 500-6)

Competition vs. Monopoly in Telecommunications

by

Lawrence F. Darby

Brian Johnson, the representative from AT&T, and I have agreed to focus on some of the more provocative issues. The topic, Competition vs. Monopoly in Telecommunications, is extremely broad. Even a modest discussion of the most critical issues could run well into the night. The other option, to discuss in detail only a few of the more important issues, could take as long. For example, a single current proceeding at the Federal Communications Commission has already attracted well over 30 respondents and generated 8000 pages of evidence, and a recent tariff filing by AT&T in response to an FCC order comprises over 50 volumes and about 16,000 pages. Now, having emphasized that the issues are both broad and intricate, I will try to highlight some of the major points.

I think it is very important to place the competition vs. monopoly issue in a proper historical perspective. The dominant theme in this perspective is the rapidity of technological change affecting the production and use of communications and communications-related services. Earlier this morning we heard a presentation using technical terms many, or most, of which simply did not exist 10 to 15 years ago; nor did the facilities, processes, or services to which the terms apply.

Communications networks take their form from several building blocks; and these blocks, almost without exception, are being dramatically improved, whether measured in terms of capacity, cost, or quality parameters. Large-scale integrated circuits, using wafered silicon chips, have literally revolutionized the design of computers, switches, and assorted terminal devices. Companion changes in transmission media--high capacity coaxial cable, microwave, satellites, and optical fibers--will continue to provide more and more bandwidth for quickly moving large quantities of digitized information in the form of voice, record, data, or video services. The developments have been compared in scope, importance, and probable impact to those commonly associated with the industrial revolution.

Technological change generally must be incorporated into the economic system and this, of course, puts pressure on the status quo. Entrepreneurs recognize new opportunities and consumers demand new, improved, and more diversified services. New technologies tend to disturb markets by opening new opportunities on both sides of the market; this is precisely what has happened and will continue to happen in the communications industry. Technological disturbance of the roughly stable equilibrium in communications and related markets has and will continue to force institutions, private and public, to adjust and adapt. That,

Dr. Darby is a consultant to the Common Carrier Bureau, Federal Communications Commission.

simply and in short, is the source of the controversy over monopoly and competition in telecommunications.

The public institution with which I am associated, and thus with which I am most familiar, is the Federal Communications Commission. The FCC is charged by the Communications Act of 1934 with regulating communications common carriers. The Commission has begun to adapt to the new technological realities and I should say a few words about how it has done so.

One of the first applications by a non-common carrier to use one of the "new" technologies--microwave transmission--was made by a private corporation, which wished to provide its own transmission capacity. The applicant had no plans to market services; rather, it applied merely to build microwave links for its own private uses. The Commission perceived no major threat to the public interest and granted the applicant the necessary radio frequencies in its now famous (or notorious, depending on your point of view) "above 90 megahertz" decision. Numerous similar applications came quickly thereafter. Subsequently, MCI applied for frequencies for the purpose of offering itself as a carrier for hire. The application was granted on grounds that MCI would be able to provide specialized services which were not available from the established carriers. Then came the specialized common carrier decision which elaborated on the MCI decision and the DOMSAT (Domestic Satellite) decision which extended the specialized common carrier decision to include satellites and enunciated an open skies policy, that is, the skies would not be reserved for established carriers. Finally, in the "resale and shared-use" decision, the Commission permitted individuals or groups to buy circuits from established carriers and to use them jointly or to resell them after adding value to them in some form or another. The thrust of these decisions has been to open up for competition transmission markets which heretofore had been reserved for regulated monopolies.

On the terminal question, the Commission entertained first a petition from an individual who wanted to put a cup-like device on the telephone to shield his voice from outside noise, as well as to provide some privacy. Established carriers objected because, they said, the device is an "alien" attachment. They also raised some questions of potential harm to the network. The Commission allowed the device and followed up with the "Carterfone" decision some years later, which further opened the national switch network for interconnection. My interpretation of the Commission's basic presumption in all these decisions is that competition will be allowed in both the provision of private lines and the provision of terminal equipment if it is privately beneficial--if somebody benefits--and if it is not publicly detrimental. That particular language was used by the Court, and I think it is fair to say that the concept aptly characterizes the FCC philosophy concerning competition vs. monopoly.

Thus, the Commission has opened two limited markets for competition. This was not welcomed by AT&T nor its 1600 independent telco

partners. Indeed, they have objected procedurally at the Commission and Brian Johnson will no doubt give you the reasons why. In general, though, the Commission has been upheld by the courts. The first principal carrier legislative response was the introduction of the Home Telephone Act. That act was not specifically sponsored by the carriers, but it was carrier-supported. Basically, it said, among other things, that there should be no competition unless the FCC could demonstrate that it would not have an adverse impact on exchange rates--or to put it another way--on intrastate and exchange services. The carriers' most recent response is, of course, the so-called "Bell Bill." It has fairly broad-based support, not just from AT&T, but from 1600 independent telephone companies and some State regulators. Nevertheless, it states generally AT&T's position and is therefore known as the "Bell Bill." The bill would establish a presumption in favor of monopoly. It would have Congress find that the intention of Congress in 1934 was to grant a monopoly. The "Bell Bill" would vest jurisdiction over interconnection with the states, reversing what the courts have determined as the proper jurisdiction of the FCC. The impact would probably be to reduce competition substantially, at least in a national sense, because regulatory responsibility would be fragmented. I was thinking, while Ira Cotton was talking about standards, that one of the possible prospects of such fragmentation would be 50 different interconnect standards. I say a possibility; I think it is not likely. In time, the wishes of the larger states, California, New York, and others, might force a national standard for interconnect. The "Bell Bill" would adopt a pricing mechanism which the FCC believes to be inherently anticompetitive; that is, it would establish long-run incremental cost (LRIC) as the standard for competitive rates. The bill would allow exceptionally low rates to "meet" competition. My own view is that not very much competition would survive under that standard, but it all depends on what kind of LRIC standard was ultimately adopted. Finally, the bill would place the burden of proof on any would-be competitor to show that proposed services are not being offered by established carriers, or are beyond the ability of established carriers to offer in the future. It is accurate to say that if the bill were passed, the small amount of competition we currently have would be eliminated. Certainly, it would foreclose any new competitive entry.

What is the impact of competition? As Brian Johnson will probably make clear, there are two schools of thought--the one held by the FCC and others and the one held by the carriers. The FCC has looked at the arguments that interconnection is going to cause technical harm to the national network. The Commission has determined that this need not necessarily result from competition in the terminal equipment markets given a proper program of registration. Has there been any economic harm? The Commission has initiated Docket No. 20003, which inquires into the potential for economic harm posed by competition. That docket has attracted 30 respondents and generated a record of approximately 8000 pages. The Commission's first report noted that there appeared to be no adverse impact of competition to date and that there was no evidence of a substantial impact in the future. Again, AT&T disagrees.

The FCC is now looking specifically at the possible impact of competition on rural subscribers. One of the main reasons the Consumer Communications Reform Act, the "Bell Bill," received such generous support last year was because many Congressmen come from rural areas; whether the facts support it or not, many owners of small telephone companies who serve those areas believe that competition will force increased rates through fairly complicated mechanisms called jurisdictional separations and toll settlements. In response to this concern, the FCC has issued a notice of inquiry and formed a joint board with the state regulatory agencies to determine if, in fact, competition will be economically harmful to some of these carriers and their subscribers. We are trying to determine which carriers might be hurt and are exploring means for offsetting that harm.

That, in a nutshell, is some of the background and issues raised by competition in telecommunications. The issues are complex, controversial, and important. They defy a simple summary.

Competition vs. Monopoly in Telecommunications

by

R. B. Johnson

Larry and I are not as far apart as you might think. Certainly, I would not quarrel with anything he said about the fact that the issues are complex, and that we could easily stay here and talk well into tomorrow about them before we even got to questions and answers. One of the difficulties in doing this kind of thing is that you sit there and you listen to the other people talk and you hear hundreds and hundreds of things that you wish you could respond to and time just doesn't allow it. So as Larry did, I'm going to try and keep my remarks brief so that we will have some time left to deal specifically with those issues which interest you, rather than having us stand up here and try to determine what we think you are interested in.

Larry mentioned the words that have become quite famous, out of the court, having to do with privately beneficial and not publicly detrimental. I think that it's fair to say, and I think he would probably agree with me, that the issue is not monopoly vs. competition, but is really more one of what is publicly detrimental and what is not publicly detrimental. As I go through the things that I am going to say this morning, I think you'll see that our concerns have to do with things which may be publicly detrimental. We have done a lot of speaking before a lot of different organizations on this kind of thing, and the main reason we do it is because we are very interested in generating a national dialogue to bring these issues out before the public for examination. We're very much concerned that the FCC has made and is making decisions, of whose impact most people are completely unaware. Naturally, we have our own views of what constitutes the public interest and we put those forward. Not surprisingly, there are others who have views that are different from ours. Our hope is that when you hear all points of view, you will agree that ours is the one that most closely represents your own way of thinking. But more important than whether or not you agree with us, we think that it's very important that you understand the issues and that your views, whatever they may be, are based on facts. That is primarily why we come out and do these debates or panel discussions or whatever you would like to call them.

I think by far the single biggest issue can be summed up by the phrase--who gets and who pays. That's something that Larry was alluding to before. He mentioned to you that there are a large number of costs in the telephone industry which cannot be allocated to a specific service because they are involved with the provision of more than one service. The most commonly used example is the telephone set and the pair of wires that connects that set to the local central office. Now, that hardware is used to make local telephone calls. It's also used to

Mr. Johnson is Manager of Public Affairs for the American Telephone and Telegraph Company.

make long distance calls. The costs associated with that telephone set and that pair of wires exist even if the subscriber who uses them makes no calls at all. Given that kind of environment, how does one determine how much of the cost associated with that telephone set and that pair of wires should be covered by revenues from local service and how much should be covered by toll service. Historically, for a lot of reasons associated with politics, economics, and technology, a rate structure has evolved which over the past decades has assigned a larger portion of those costs to toll services or long distance service or message telephone service or whatever you want to call it--the basic long distance telephone service. The purpose for doing that was basically to allow regulators and telephone companies to keep the rates for local residential service low, and therefore, widely affordable to contribute to what Larry referred to as universal service so that everyone who wanted a telephone could have a telephone. That outcome, that rate structure is really not too surprising. That is basically the objective that Congress articulated in the front end of the Communications Act of 1934, and we believe that that's how we got the rate structure that we have today. Now this particular rate structure has been pretty successful in holding telephone rates low for local residential service, but it has one very difficult point to it; that that rate structure makes long distance telephone service very vulnerable to competition. Let me give you an example of what I'm talking about. If a businessman who has his business in New York makes a large number of calls to only two cities--let's say Chicago and St. Louis, and let's say that he runs up maybe \$100 phone bills month after month after month in the process of conducting his business. He may opt for a specialized private line service between these cities at a reduced cost. Here is where a so-called specialized service and long distance telephone service are very clearly in competition for the same customer dollars. That's a reasonably simple example, but today in the business world, there are similar kinds of dislocations which are taking place every day which demonstrate that same principle. So when people tell you that in the field of intercity communications, competition has been limited to a very narrow portion of the market, please view that statement with some skepticism.

Now that's the basic problem. There are just a ton of other issues. Larry touched on quite a few of them having to do with technical protection of the network and so forth and so on. Rather than get into those, what I'd like to do in the next few minutes is lay out for you what I think should be the national objectives used in setting national policy for telecommunications.

I think the first objective should be availability. By this, I mean that telecommunications services, to meet a wide variety of needs, should be obtainable by users in any reasonable geographic area at affordable rates. Now there is a lot to that. There are basically three components to what I just called availability. One is affordable rates--we've already talked about that. The next is geographic availability. That's the thing that Larry mentioned. Who serves the guy on the bottom of the Grand Canyon or on the upper peninsula of Michigan,

and can he be served at rates that he can afford to pay? If the carrier provides service at a rate that loses money, how is he compensated for that? The last component that I talked about was variety. There is no question that technology is bringing forth greater and greater demands for various applications, especially in the data field, and this is the area where there is room for competition. There is room for the packet switching networks that Ira was talking about this morning. And national policy should foster that kind of thing.

The second national objective should be quality. Again, quality is multifaceted. First of all, services should be adequate for their intended purpose. In other words, they should perform properly. As I'm sure you have heard, the National Telecommunications Network is a conglomeration of millions of interrelated parts. With us, compatibility is a constant concern among all of these parts. We have found and we believe that the principles of systems engineering are imperative to the proper functioning of a national network. We think that that's the only way that we can continue to get satisfactory performance out of that network. If quality means performance, it must also mean reliability--reliability in that you can get a new service installed in a reasonable amount of time when you want it; reliability in getting outages repaired quickly. Here again, we think that reliability is based on systems concepts. Anyone who has suffered through the resolution of the computer systems problems involving multiple suppliers can appreciate our concerns over increased restoration times in a similar environment for communications.

Now, having said all that, you're probably wondering if there is anything that we see in the telecommunications area that is suitable for competition. That's essentially the question that Senator Harrison Schmitt of New Mexico asked John DeButts, AT&T Chairman, in his recent appearance before the Senate Subcommittee on Communications. Mr. DeButts responded just recently in a letter to Senator Schmitt and to the subcommittee in which he delineated the areas that he thought were appropriate for regulated monopolies and the areas that he thought were candidates for competition.

He started out by saying that those things that conform to any one of three criteria should be provided on a regulated monopoly basis. The first criteria applies to areas which exhibit significant economies of scale and scope. In other words, any place where you can demonstrate that there are clearly natural monopoly tendencies which have a significant impact on the efficiency and cost of the provision of whatever it is we're talking about in the market. The second was areas in which competition would undermine an industry structure which exists for the purpose of achieving or maintaining a Congressionally established national objective. The third was areas in which the potential hazards to the National Telecommunications System under competition so outweigh the potential advantage or the potential benefits that the risk is simply not worth taking. He then proceeded to identify those areas which, in his opinion, would become regulated monopoly areas under such a definition. There were four of them. The first was the provision of local

exchange service, including a single carrier-provided telephone instrument. The second was the provision of virtually all transmission facilities. The third was the provision of message telephone service (MTS) or ordinary long distance service. And the fourth was the provision of any service which is sufficiently cross-elastic with long distance service to threaten its ability to contribute to keeping local rates low.

Finally, he delineated the remaining areas which, with adequate safeguards, he felt could be considered candidates for competition. Again, there are four. The first was the provision of transmission facilities which do not duplicate the infrastructure facilities either by virtue of not being functionally interchangeable with or not serving the same geographical locations as those facilities. The second was the provision of services which are unique and not substitutable for or cross-elastic with MTS or local exchange service. He recognized that a reliable means had to be developed to test new services to determine what their relationship is with MTS and local service. The third area that he felt was a candidate for competition was the manufacture and supply of telecommunications equipment--that equipment sold to telephone companies to be used in the providing of telephone service. The fourth area that he said he thought was a candidate for competition was all terminal equipment with the exception of a single carrier-provided telephone associated with local telephone service. However, he urged at the same time that adequate safeguards be provided to insure that the public network is not harmed through interconnection and pointed out that AT&T and the rest of the telephone industry continues to disagree with the adequacy of the FCC Registration Program to accomplish that objective.

Now, there in a nutshell, along with what Larry has told you, is the question of competition vs. regulation in telecommunications. I have tried to summarize for you in a brief period of time, what I think is important. I've tried to give you my ideas of what I think would be appropriate objectives for Congress to use in their coming activities in deciding the future of telecommunications in this country, and I hope you agree with me. But, as I said before, more important than that, I hope that the resolution of these issues will not be reached in the absence of your attention and your concern.

The National Bibliographic Telecommunications Network

by

Henriette D. Avram

A better title for my presentation might have been, "Networking Activities." I, in common with most of the others in this room, cannot predict with any certainty the precise configuration of the network, the responsibility to be assigned to various components, the locus of network management, precise network configuration or participation, sources of funding, and several other details. However, one thing is obvious--the network is evolving.

The National Commission on Libraries and Information Science--a commission appointed by the President of the United States--recommended the establishment of a National Library and Information Service Network. The study said that the network would consist of three coordinated parts, and I quote:

A resource system designed to provide guaranteed access to all needed materials. A bibliographic system designed to provide a unique authoritative bibliographic description for each item held in the guaranteed access, as well as the locations of such material. A communications system designed to provide on-line communication of bibliographic data and requests for data and services between the various levels of the network.

The three parts, the resources, the bibliographic and the communications systems are depicted in figure 1. You will note that the universe has been called the National Library and Information Service Network, borrowing from the commission. I am going to confine my presentation to the library bibliographic and communications components of the universe. This limitation is a result of several events, and for those of you who are unfamiliar with library automation activity over the last decade, I will briefly describe to you why we are limiting our efforts at present to the library bibliographic component of the universe.

It was not until the 1960s that the automation of libraries became a matter of serious interest. There is no doubt that the Library of Congress's MARC project, which made cataloging data available in machine readable form, had a major impact on library automation development. For the first time, a format for the presentation of such data was available as a distribution service of the Library of Congress (LC). Thus, a basic ingredient for automated library systems was provided from a central, national source. The libraries desiring to automate did not have to start from ground zero. Although library activity accelerated

At the time of the Conference, Dr. Avram was Director, Network Development Office, Library of Congress.

NATIONAL LIBRARY AND INFORMATION SERVICE NETWORK

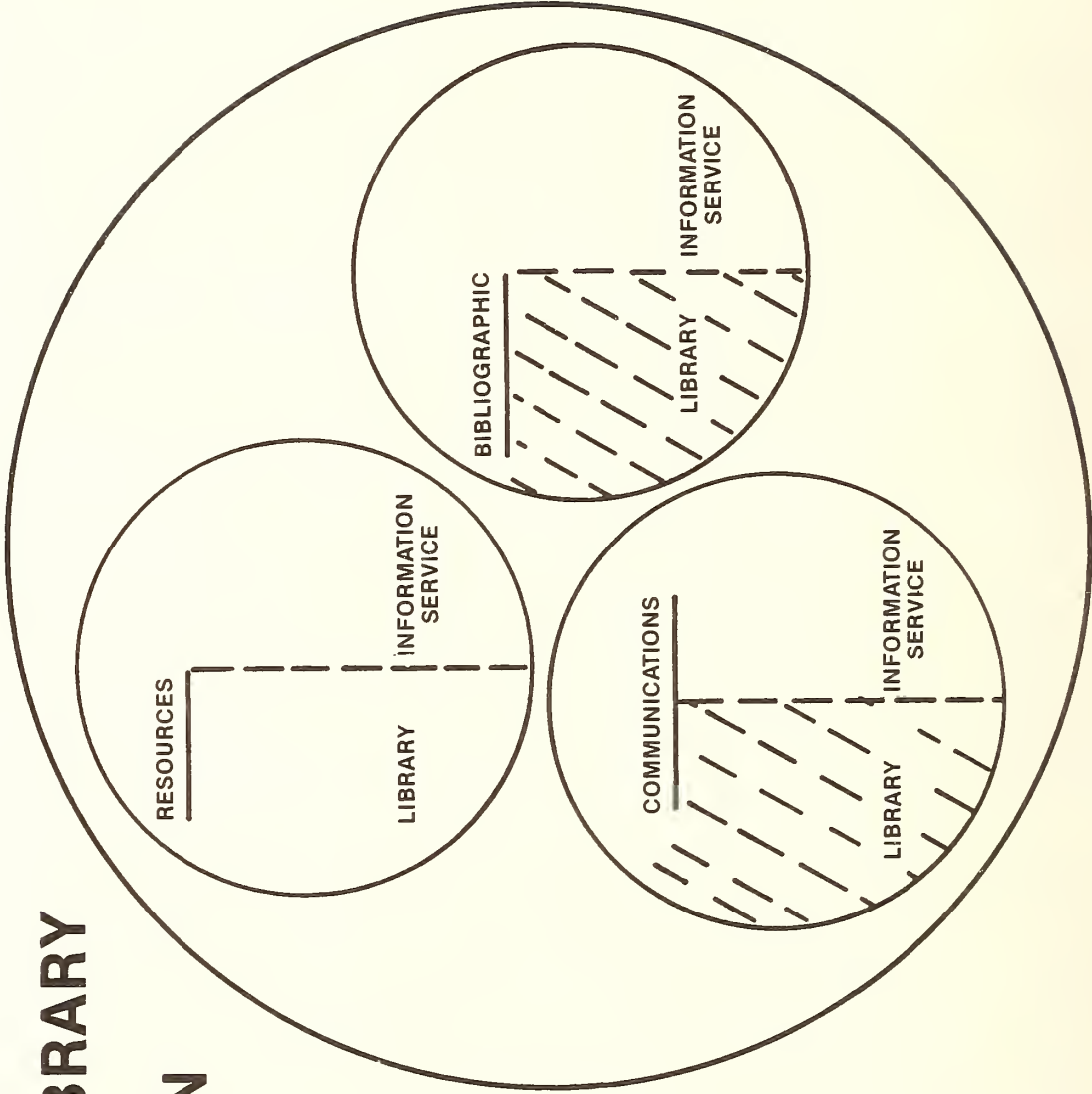

LIBRARY BIBLIOGRAPHIC COMPONENT

Figure 1.

in the 1970s, we saw the creation of few new stand-alone library systems; that is, we did not see systems being built for automating the operations of a single institution; rather, efforts were concentrated on computer-based systems to serve the processing and public service needs of many institutions.

During this same period of time, LC was very much involved in the design and implementation of its own processing system, which has become known at the Core Bibliographic System, and its National Bibliographic Service--a service designed to serve the needs of the nation's libraries by providing products from data generated in LC as well as from data input from outside national and international sources. Networking activities emerged as a dominant trend about this same time. LC, as part of its National Bibliographic Service, has initiated several projects which are building blocks of this information network. These permit the use of LC's bibliographic data by other institutions in an on-line mode. In addition, these projects involve the input of bibliographic data by other institutions, national and international, to build a national data base. Figure 2 shows the National Bibliographic Service, the input of LC records, MARC cataloging records, in-process records, subject and name authority records, and location records. Other institutions contribute to the building of a national serials data base (about 14 participating institutions) and the COMARC Data Base of book records (about 12 institutions in a batch, rather than an on-line, mode). We look forward to the input of non-LC cataloging records in machine readable form. In addition, we hope to build our authority system, and we are already inputting the location reports of other libraries. From the National Bibliographic Service, we are providing machine readable data, printed products, microform products, and on-line services. Figure 3 summarizes the services that are available today. MARC covers books, serials, maps, films, subject headings, and soon, names. From our automated system, we produce printed products, such as cards, book catalogs, the register of locations, and the LC subject headings list. Microform products include the Register and the Subject Headings, and we have one interactive network in operation with the Research Libraries Group, which I will describe in more detail.

In the 1970s we began to see the formation of the bibliographic utilities--organizations that offered computer-based services to a number of libraries. Some of these utilities include BALLOTS, the Ohio College Library Center (OCLC), the Washington Library Network, and others, with OCLC, of course, being by far the most advanced. Organizations acting as brokers or distributors of computer-based services from one or more bibliographic utilities have also developed. These service centers are of various types--multistate, statewide, intrastate--serving a variety of clientele. This proliferation of activity seemingly had no direction. It was just as though networking was a game and anyone could play. It was this situation, plus the question of a proper relationship among these developing systems and LC and its national service, that prompted the library to create an office, the Network Development Office, and also a Network Advisory group. The Network Advisory Group, composed of senior representatives of many

NATIONAL BIBLIOGRAPHIC SERVICE

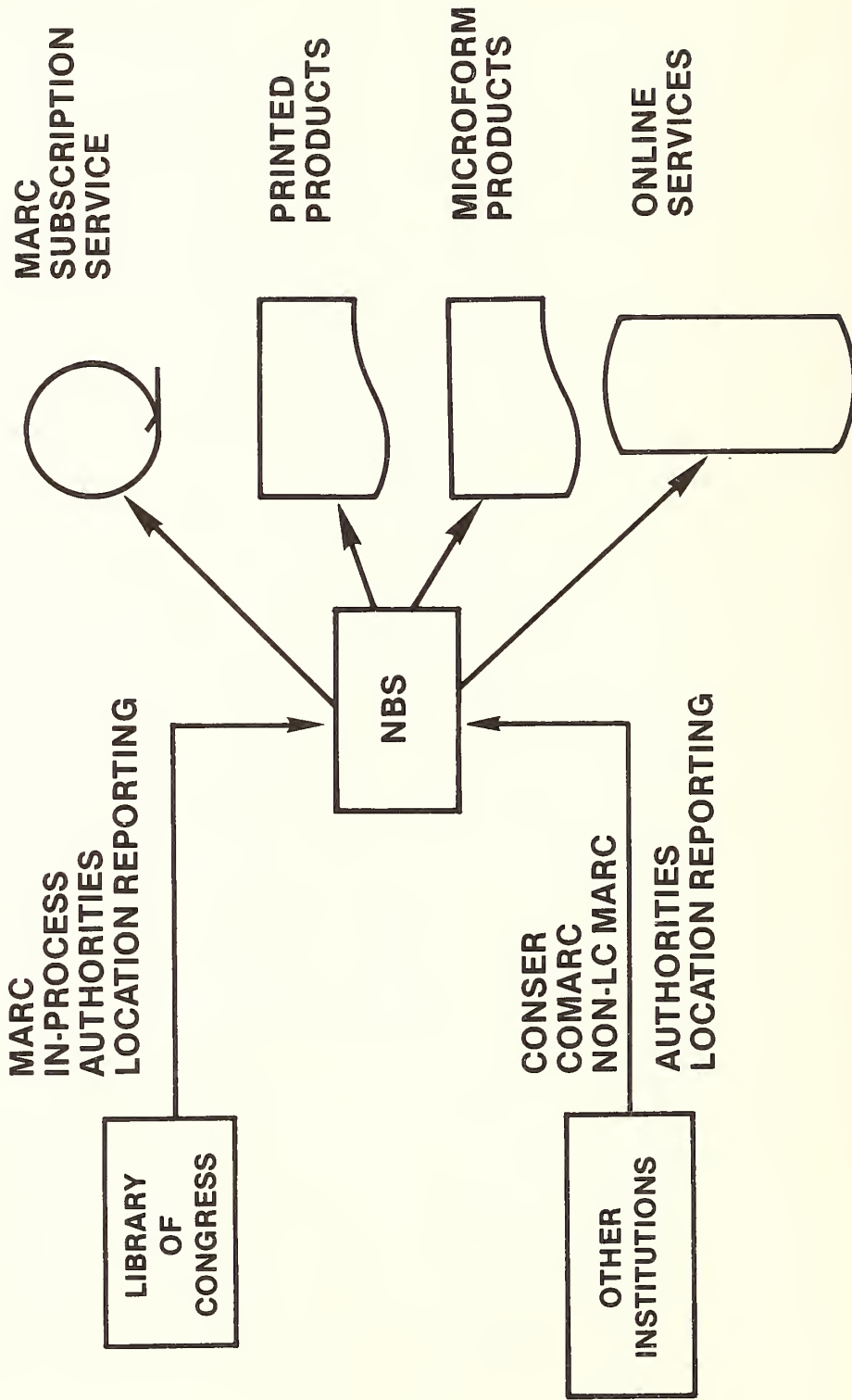

Figure 2.

SERVICES IN OPERATION FROM AUTOMATED SYSTEM

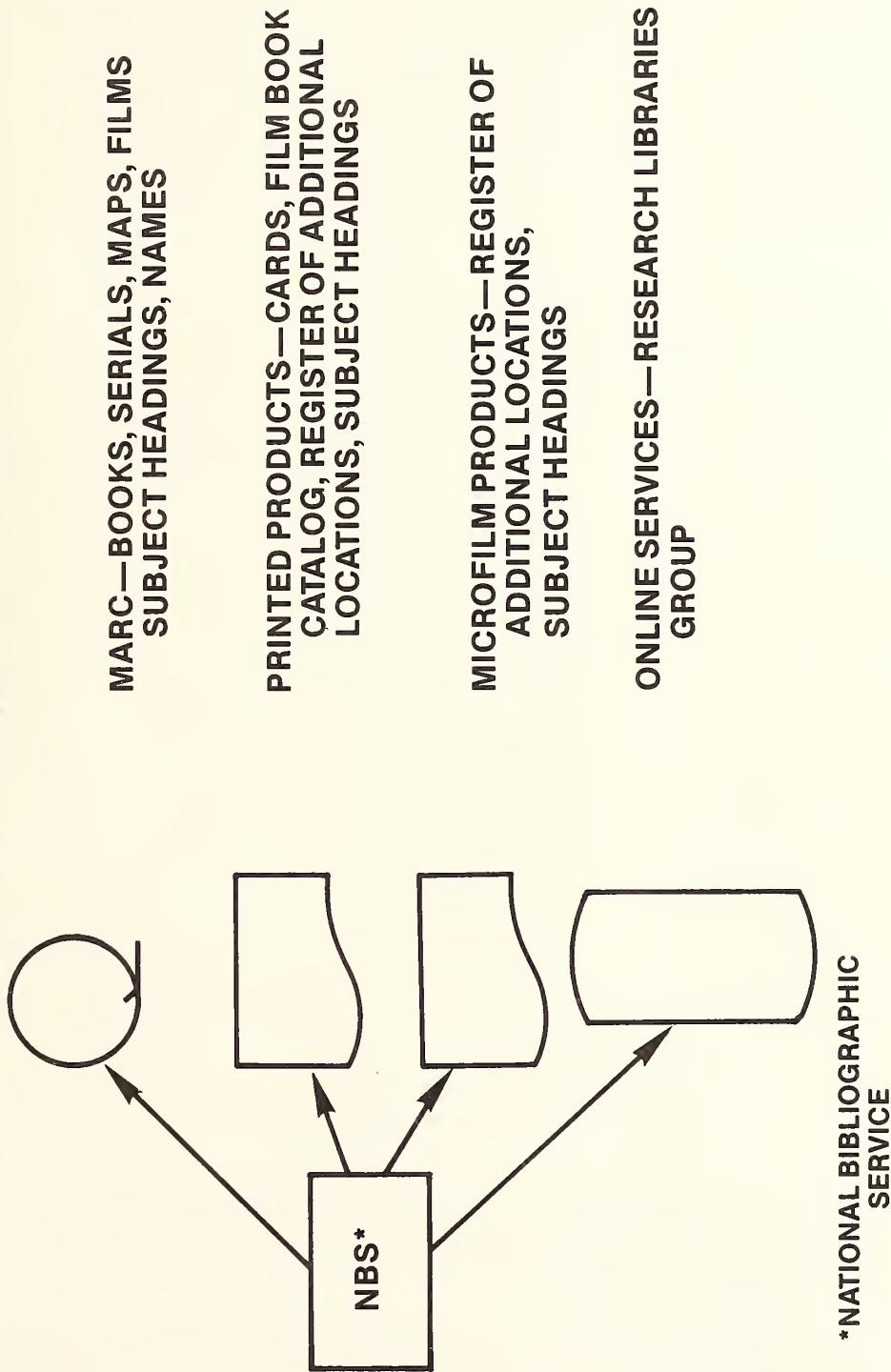

Figure 3.

ongoing systems, was asked to act in an advisory capacity to the Network Development Office. The initial output of the Advisory Group was a working paper. The working paper is not a national plan, but rather recommendations of some first steps towards coordinating the many disparate elements in the direction of an integrated system. Early in its deliberations, the Advisory Group narrowed the scope of its paper to the library bibliographic component of the larger network--the National Library and Information Service Network. We all placed equal importance on the other components of the information community, as well as the need for an effective resource-sharing system for all members of the library and information community. But in an attempt to begin, only that one component was to be addressed. This, then, takes us full circle back to the limitation and the reason why I am talking about the library bibliographic component.

The Network Advisory Group identified a series of tasks and divided these tasks into three categories. The first category of tasks was assigned to the Network Coordinating Agency. Their tasks included the design of the technical network configuration or architecture, the determination of the role of authority files in the network, the determination of the legal and organizational structure of the library bibliographic component, and the determination of the configuration of the national data base.

The second series of tasks were given to the operational units of LC. In order for LC to play its role in the evolving system, it needed to conduct a study to determine hardware and software configurations needed to operate the National Bibliographic Service; to communicate with outside libraries on existing or proposed bibliographic services; to make available all appropriate internal LC bibliographic, authority, and holdings data bases; to determine a pricing structure for these products; to design and implement an on-line LC authority system; and to provide the interface with the network authority system. LC has now set a policy to make its bibliographic data bases available on-line. We are also engaged in setting a pricing structure. Additional tasks for the LC operational units were: 1) to design a remote entry input system; we are now doing this as part of the CONSER project; 2) to design and implement a system to make available international MARC records--we are very much involved with the international MARC scene, but at this time, the only MARC tapes that are available are those from Canada and this needs to be expanded; 3) to design and implement retrieval or query systems to provide on-line access to the bibliographic and location records--retrieval is available but requires expansion.

The third series of tasks were specified as the responsibility of other network organizations. Their task was to define the role of State and multistate networks in the library bibliographic component, including goals, assumptions, objectives, functions, and tasks specific to these network organizations.

I am going to confine my presentation to work in progress by the Network Coordinating Agency. Since there does not exist a Network

Coordinating Agency, the Network Advisory Group recommended that the LC Network Development Office assume this role as an interim measure. We have done that.

What we have tried to do is to work at all times with other network-related organizations. This is a task of coordination. The approach has been to keep working groups small and to the point. Figure 4 shows the relationship of the major activities underway. The Network Development Office is being advised by the Network Advisory Group. The Network Technical Architecture Group, which has become known as NTAG, is a result of one of the high priority recommendations of the Network Advisory Group. This group is concerned with the technical architecture of the library bibliographic component of the system. Ira Cotton's paper this morning was great because he provided the tutorial needed to understand what this group is trying to do. NTAG has two primary objectives. The first is the design and implementation of the interconnection of the bibliographic utilities: OCLC, Washington Library Network, BALLOTS, NELINET, University of Chicago, and others. The second is the determination of the configuration of the national data base. The design and implementation of the interconnection of the bibliographic utilities will be the first project undertaken. NTAG has divided this project into three subprojects, each subproject being a self-contained useful task which builds on the prior subproject, finally leading to the accomplishment of the principal mission of interconnecting the bibliographic utilities.

The purpose of the interconnection of the bibliographic utilities is to share bibliographic data. For example, if an item is cataloged on one system, the user of another system transparent to him, should be able to retrieve the record from the remote system for use in his own system. Likewise, by linking the bibliographic utilities, interlibrary loans should become more effective. A user requesting an item which cannot be found in the institution of his region could possibly locate that item in a remote library by having his system access the location of items in another system.

The first subproject is to link the bibliographic utilities to the Library of Congress using current Library of Congress protocols. The reason we are using Library of Congress protocols is that standard protocols are not yet available. This project will create a network enabling each of the bibliographic utilities to link to the LC system. This project is a logical extension of an existing project, the Research Libraries Group-LC computer-to-computer link that is now being tested in an operational mode. In April of 1976, the Research Libraries Group (RLG) and LC began a joint pilot project to establish communication links between the RLG host computer, the New York Public Library computer, and the LC computer. For cataloging purposes, staff members of the RLG libraries search the RLG data base residing in the New York Public Library computer for records. If the desired record is not in that file, the search query is transmitted to the LC computer invoking the LC searching system. If a record is found, that record is transmitted back

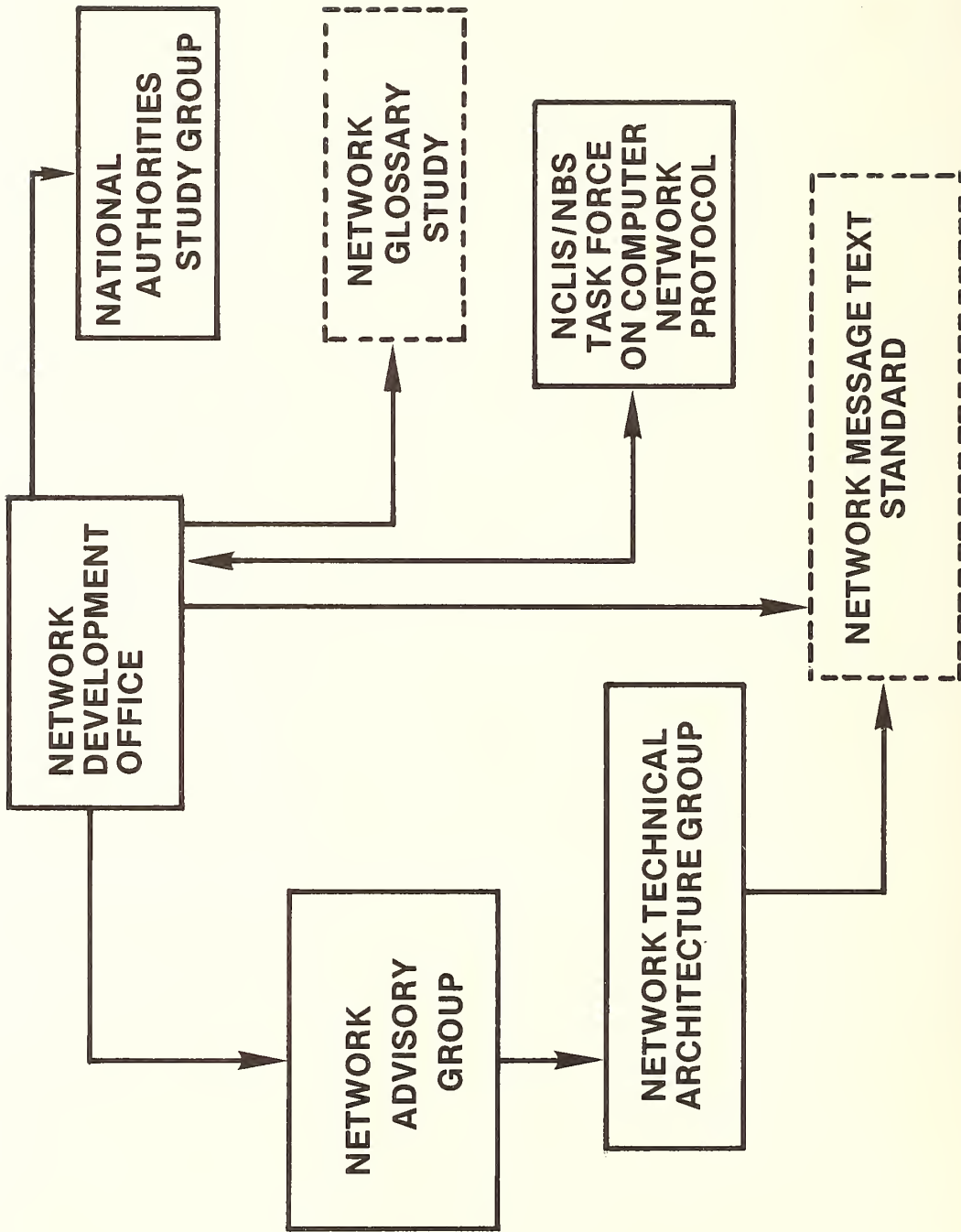

Figure 4. Interrelationship of LC networking activities

to the New York Public Library computer in the MARC communications format for further processing.

The second subproject will upgrade the system I just described by the use of standard protocols, both the protocols being established at the application level by the NCLIS-NBS Task Force on Computer Network Protocol and the networking level standards that Ira Cotton talked about--X.25. This will upgrade the system that exists to connect the utilities to LC.

The third and final development will be to extend the system that exists to provide bi-directional capability between the bibliographic utilities to allow each system to access the bibliographic records of all the other systems including LC.

The first project described--the linking of the utilities to LC--is the subject of a joint proposal now being written by seven institutions. The proposal seeks funds to expand not only the RLG service to the other institutions, but also to expand the service itself to a variety of services including some which will be beneficial to LC itself, as well as to the other utilities in the network. By expanding the number of participants, links will be established across a broad geographic base to utilities serving, in some instances, a totally different kind of clientele. The trade-off between the cost of storage of bibliographic records at many institutions versus the cost of data communications to access records on demand will be more effectively tested. The organizations that are involved in the proposal writing believe that this is the first time that such a joint proposal has been written for a project of national scope. This is significant in that, from the onset the system is being built in unison, with the result that each organization is aware of what the other one is doing. Where possible, procedures will be shared, equipment will be rented or purchased by joint agreement, and the results, which will provide experience for the subsequent steps, will be analyzed by the group as a whole.

During the course of its deliberations, the NTAG Group recognized that the NCLIS-NBS Task Force was concerned with control information protocol, i.e., protocol that will describe types of transactions, message source, message destination. There is still a need in the eventual network for standard message formats; for example, a standard query text, a standard bibliographic text, a reply text, an error text. NTAG agreed that this work could best be started by a contractor and that a formal proposal should be submitted to the Committee for the Coordination of National Bibliographic Control stating that a consultant should be engaged to study existing systems and make recommendations for standards to be used to communicate between the utilities. For those of you who do not know what the Committee on the Coordination of National Bibliographic Control is, let me give you a brief description. This committee represents members of the various components of the information community: publishers, abstracting and indexing services, libraries, information centers, and others. It was started as the result of a conference held about three years ago to explore what could

be done to bring the various segments of the information community closer together. The committee is funded by the Council on Library Resources, the National Science Foundation, and the National Commission on Libraries and Information Sciences. NTAG offered to act as the monitoring agency for this work. The committee agreed to fund the study. NTAG has written the study objectives and the task definitions; we are presently negotiating with a consultant to perform the work.

If you study figure 4 again, you will see at the bottom the Network Message Text Standard which again coordinates one more committee and one more project. We have talked about the Network Development Office, the Network Advisory Group, the Network Technical Architecture Group, the Network Message Text Standard, and the NCLIS-NBS Task Force. The Network Development Office has a member on the NCLIS-NBS Task Force and the Network Technical Architecture Group is composed of technical people, several of whom are on the NCLIS-NBS Task Force.

Other work in progress by NTAG includes a cost trade-off comparison study between the value-added networks and leased lines. That study has been completed. We have also defined the functions of the Host Front End Processor, which would include such procedures as formatting, character conversion, the functions of the Network Front End Processor, the standard processor, and the interface that Ira Cotton was addressing, which includes such procedures as data transmission, management information, maintenance, and interface to the host. The Network Development Office has also completed a project activity planning technique. We have defined the tasks that are needed and we are slowly but surely filling them in. We are writing the project proposal and we hope to have that proposal ready for funding institutions by August or September. This group meets approximately once a month. The first few meetings were funded by the Research Libraries Group as part of their task, but the remainder of the meetings are funded by the Council on Library Resources.

The second task of the Network Technical Architecture Group is to configure the National Data Base. When we talk about the National Data Base, we are talking about the bibliographic data base, the authority data base, and the location data base. We cannot talk about one without the other. If again you will look at figure 4 you will note, off to the right, a National Authorities Study Group. This project was started by the Network Development Office prior to the formation of the NTAG Group. We started out with the definition of a project--define the role of the authority file in a national network. The first proposal written was so complex that we divided it into two phases. The first phase was called methodology--in other words, tell us how to do the second phase. The methodology ended up not being quite a methodology, but rather has taken us well into the configuration of the National Data Base. However, we also discovered we really were not talking about the role of the authority file in an evolving network. We all know the role of an authority file. The role of an authority file is to control individual catalogs. The problem was, how do you extend that role? What are the difficulties? We want to extend the role of the authority file to a

national union cataloging data base, and I do not mean for the printed edition, I mean for a machine readable data base, that is being built cooperatively--that really is the problem.

A study was funded by the National Commission on Libraries and Information Science concerning the role of an authority file in a network environment. The administrative and technical direction of the study was under the Network Development Office and the principal investigator was Edward Buchinski of the National Library of Canada, who probably knows more about mechanized authority files than anybody else. We formed an evaluation team of those people who had some experience with machine readable authority files, the National Authority Study Group. They included representatives from the New York Public Library, Boeing Computer Services who did the systems for the Washington Library Network, the Library of Congress, the National Commission on Libraries and Information Science, and also a representative from the Committee for the Coordination of National Bibliographic Control (the committee was also looking at the problem of authorities) to sit in as part of the evaluation team. The project has been completed and I have the final report. We have defined approximately 16 tasks for phase two. All of this work will be input into the Network Technical Architecture Group as part of its second task.

I talked about four existing groups--the Network Advisory Group, the Network Technical Architecture Group, the NCLIS-NBS Task Force, and the National Authority Study Group. When you work with all these groups, you rapidly discover that you are all using different words to mean the same thing. There needs to be a glossary defining new terms. We are having trouble communicating with each other. I have asked LC and they have agreed to fund a glossary study. We are not attempting to put together a complete dictionary, but rather to come up with about 100 to 150 terms, so that when the terms are used across the community, they will mean the same thing to all of us. One member of each of these four groups will serve as a liaison or representative of that group to the contractor who will be doing the work. At this time, we are negotiating with a contractor to start the effort.

In summary, the Network Advisory Group gives direction to networking efforts by assigning specific tasks to working groups. Although each working group is a separate entity, individuals serve on more than one group and each group is briefed on the activities of the other groups. This approach creates an environment conducive to working together toward the building of a system composed of existing systems but integrated into a workable whole.

Progress in the Development of Computer Network Protocols
for Library and Information Service Applications

by

John L. Little

The National Commission on Libraries and Information Science (NCLIS) has appointed a Task Force on Computer Network Protocol comprised of seven experts from organizations that are actively engaged in operating computer networks serving various bibliographic and cataloging needs of libraries around the United States, some on a national basis, and some on a regional basis. That Task Force is actively attempting to develop standards to facilitate the nationwide needs of libraries and library-related activities which can best be satisfied by computer networks and large data bases. A substantial portion of the Task Force endeavor is the development of a consistent terminology which does not conflict with the terminology used in associated fields, such as the telecommunications field. The task force is attempting to build these standards upon a base of existing domestic and international standards in the field of computers, communications, and information processing.

A good snapshot of such related standardization is contained in the recent NBS Special Publication 500-6 entitled Computer Network Interconnection: Problems and Prospects (see reference). That publication defines "computer network" as "an interconnection of assemblies of computer systems, terminals, and communications facilities." It also defines "protocol" as "a formal set of conventions governing the format and relative timing of message exchange between two communicating processes."

Figure 1 shows four levels of protocols involved in computer networks. Other levels could be postulated. The real world of hardware is at the bottom, where the horizontal line can be copper wire, coaxial cable, microwaves, satellite links, laser beams, fiber optics, and the like. The hardware protocol involves signal levels, analog versus digital techniques, signal polarities, pulse rates, unbalanced versus balanced (one signal versus push-pull signals), electrical, optical techniques, and other physical matters.

The data communications link protocol involves grouping bits received from the host level, adding error control bits, checking for the detection of errors, correcting errors by logical means or by retransmission of faulty blocks, and other techniques to get data from one end of a link to the other in a reliable and controlled fashion.

Mr. Little is a member of the technical staff in the Center for Computer Systems Engineering, Institute for Computer Sciences and Technology, National Bureau of Standards. He was coordinator of the 1976-77 NCLIS/NBS Task Force on Computer Network Protocol.

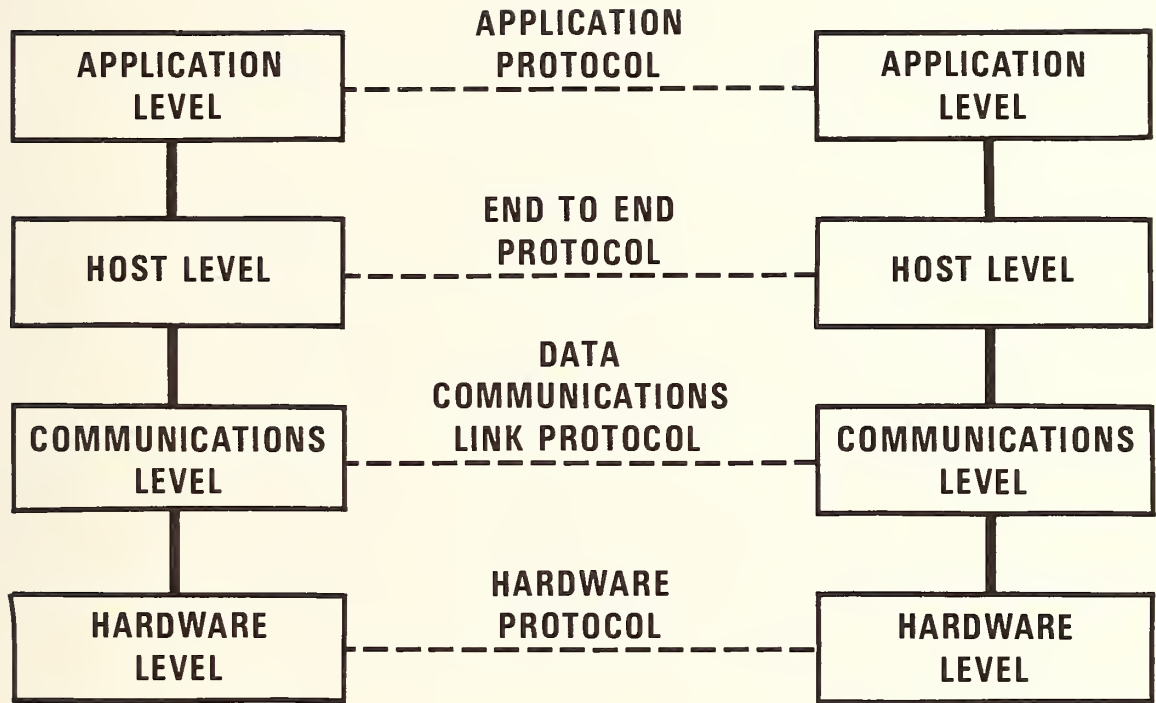

FIGURE 1.

Four levels of protocols involved in computer networks

The "hosts" in the next level are the actual computers (at libraries, bibliographic service centers, book vendors, and related organizations). The end-to-end protocol takes place between one host computer and another, and involves a separate level of error control as a gross check on the lower level protocols. If great confidence could be placed upon the correct functioning of the lower levels, then end-to-end protocol would not be necessary. The end-to-end error checking verifies that the data are received correctly and that the lower-level blocks have been reassembled in the original order. There are standards or proposed standards for the three lowest levels and the interfaces between levels. These are described in the Special Publication cited heretofore.

The application level is the real province of the Task Force effort, in this case for the computer-to-computer exchange of library/bibliographic search/cataloging/book vending information. The application level protocol involves the addressing, identification, and control required to pass data between a process (program) in one host computer and another process (program) in a different host computer on the network. The information at the application level comprises header (control) portions in all messages and it may also contain a data portion in some messages.

The complete collection of bits which comprise header control and data at the application level are passed down one level and treated entirely as data in the end-to-end level, where more bits are added for identification and error control purposes before being passed down to the network or communications link level, where still more bits are added for routing, blocking, and another level of error control.

Thus, as the information is passed down the hierarchy from one level to the next, new header and control information is added to provide an "envelope" for the information from above. After transmission, as the information is passed up the hierarchy from one level to the next, the successive enveloping controls are removed, so that at the top, application level, an exact replica of the original message is received. In the receiving process program, the message is divided into control information and data, and acted upon accordingly. This Task Force has made the assumption, with fingers crossed, that the application messages will be received correctly and in the proper sequence.

The formats being developed and described by this Task Force for the application level headers are for the computer-to-computer exchange of library search, bibliographic documentation, and book-ordering information. It is not a protocol for librarians to compose. Librarians should be able to continue to communicate via terminals to their own host computers, in a familiar format, and the host computer, guided by these formats, would be required to reformat this information into the format of the library network protocol before it is sent over the network to another host computer.

In interchanging information between computers, it has been recognized for several years that there are really only two choices: 1) use an identical computer architecture at each site, and interchange data in the native codes and formats of these computers, or 2) interchange using only strings of standard characters, such as ASCII characters, and allow each character to have only its standard meaning. In the real world of dissimilar computers, only choice 2) is available, and the NCLIS/NBS Task Force on Computer Network Protocol is pursuing it.

Since the extremely fast moving computer industry is only 25 years old, the standards at all levels are still very fluid and dynamic in their development, which adds an interesting dimension to the work of this Task Force. To attempt some stabilization, the Task Force is confining its attention only to the highest application level, and in particular is restricting its efforts only to the header portion of messages. But some fundamental decisions needed to be made before even that could be attempted.

Figure 2 shows a "library bus" or electronic data communications network interconnecting the Library of Congress, some bibliographic service centers, regional processors, book vendors, and the like. A fundamental decision had to be made regarding the use of "point-to-point" connections, "star" (multipoint-to-point) connections, "broadcast" messages on the bus, or point-to-point messages on the bus. Point-to-point messages on the bus was chosen. Any message from a host is addressed to only one other host on the network (bus). Only one host should respond to or receive any particular book for an interlibrary loan. A broadcast type request, if it were permitted, might turn up a fast reply from dozens of sources. The originating host would then need to decide which one to pursue. There would be many one-way messages with or without acknowledgment. The same could be said about the seeking of price quotations for the purchase of new books. It was decided that any "originating" host would select one "target host" and for a given "session" exchange messages with that host only, over the library bus network.

The expressions "originating host" and "target host" were coined to describe the status of two hosts during a particular session. During that session, messages flow in both directions, but any particular message flows in only one direction, from its "source" to its "destination."

Some other terms that have caused some confusion are shown in figure 3. A session between two host computers can involve more than one kind of process, such as cataloging or ordering. A process such as cataloging can involve several types of transactions such as search or editing. Each of these transaction types can in turn cause several different types of messages to be generated.

Some of the foundation for this work is based upon the American Library Association's Information and Science Automation Division (ALA/ISAD), which identified: a) routing, b) target facility action

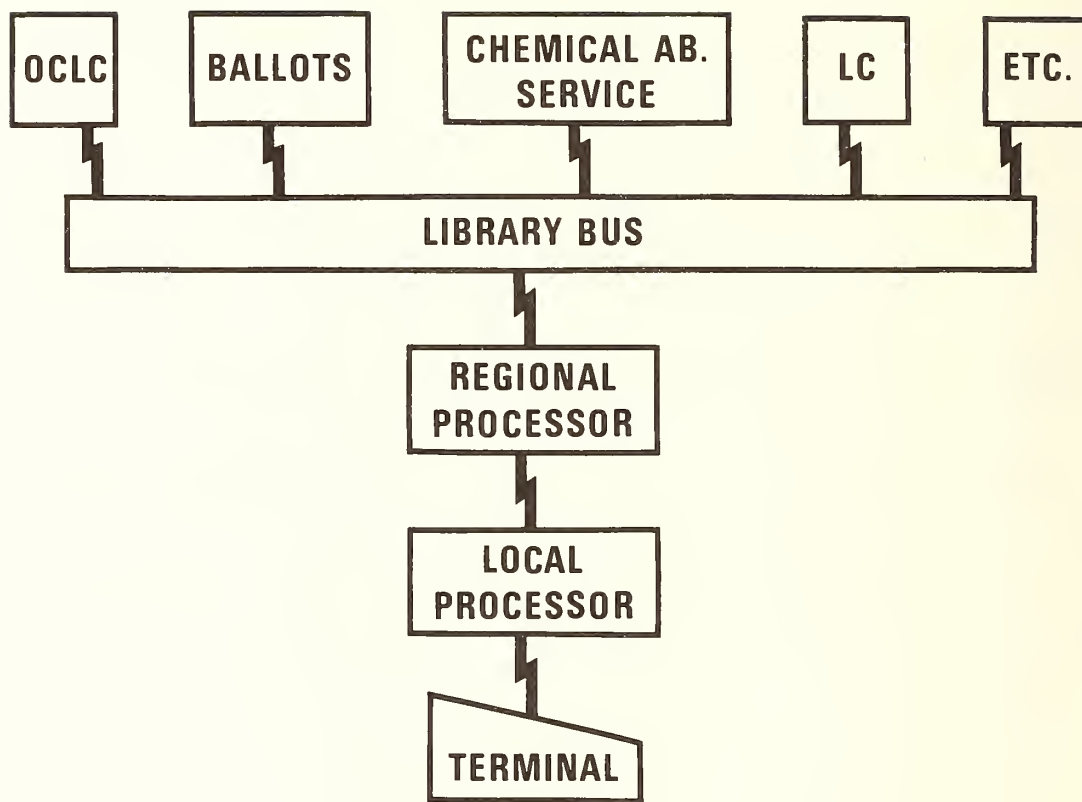

FIGURE 2.

"Library bus" or electronic data communications network interconnecting the Library of Congress, some bibliographic service centers, regional processors, book vendors, etc.

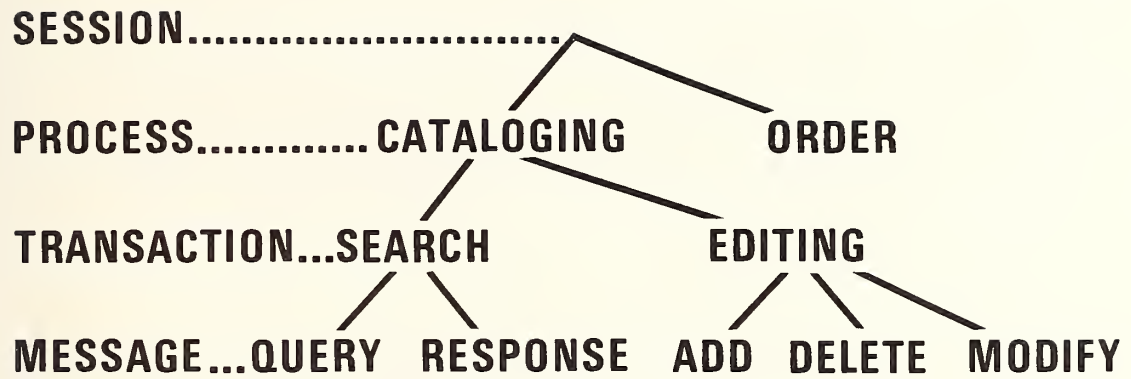

FIGURE 3.

Terminology

SELECTED LIBRARY FUNCTIONS RELATED TO NETWORK APPLICATIONS

ACQUISITIONS

- **FINDING A CITATION; PRE-ORDER SEARCHING**
- **ORDERS TO VENDORS; LATER CLAIMS, CANCELS, RESPONSES**
- **SEARCH & QUOTE**

CATALOGING

- **BIBLIOGRAPHIC SEARCH; SEARCH ALGORITHMS**
- **INPUT, FORMATTING, OUTPUT**
- **NOTIFICATION & SHARING**

CIRCULATION

- **COMMUNICATION WITH LOCAL CIRCULATION SYSTEMS**
- **INTER-LIBRARY LOANS (FIND CLOSEST COPY)**
- **NEGOTIATING BILATERAL AGREEMENTS**

REFERENCE

- **INDEXING & ABSTRACTING**
- **CHECKING FOR CROSS-REFERENCE INFORMATION**
- **"AUTHORITY" FOR CLASSIFICATION (LIBRARY OF CONGRESS, VARIOUS LIBRARIES)**

FIGURE 4.

control, and c) billing as three major types of computer networking messages. These messages provide four main computer-related functions for libraries, as shown in figure 4, for acquisition, cataloging, circulation, and reference services.

A message will be structured in accordance with the layout shown in figure 5. The overall message structure, shown at the top, is 1) header length (including the length field), 2) headers, 3) length of the data field, and 4) data fields of any length up to a maximum. This Task Force is concerned primarily with the structure of the header fields. Each header field will have the structure shown in the middle line. An operating (op) code of one octet (8 bits) will give the type of header field. The second octet (or second and third octets) will give the length of the header parameters field, and finally there will be the parameters whose individual lengths are included in the specified length.

A more detailed example is shown on the bottom line. The first octet has a value of "1" indicating an op code for a source/destination address header field. The second octet has a value "8" which says that the parameters occupy 8 bytes, and as shown 4 of these are for the source address and 4 are for the destination address; within each of these 4 bytes, 2 are for host identification and 2 are for unit identification.

The first octet will probably be an 8-bit binary number, so that the number of op codes can increase up to 255 (or 256 if zero is allowed). This means that the bit patterns for ASCII or EBCDIC control functions can occur in this octet, and hence the communication techniques must allow for "transparent" end-to-end communication. This can readily be done with the new family of evolving communication standards typified by the ANSI Advanced Data Communication Control Procedure (ADCCP) standard which has recently been brought into consonance with the ISO High-Level Data Link Control (HDLC) procedures. Further details on ADCCP and HDLC are given in Computer Network Interconnection.

Ten other types of header op codes are shown in figure 6. Some of these use only one address, and hence will be even shorter in length than the source/destination address field.

As is evident, the Task Force is concerned with bit-structure detail for the header portion of the highest level, the library and information service application level. This Task Force is not concerned with the data structure at that level, nor with bit details at any lower level. Details outside of the application-level header are being developed by other closely-related groups, such as the Network Advisory Group (NAG), to the Library of Congress, the Network Technical Architecture Group (NTAG), a working group of the NAG, and the Authority File Group, sponsored by NCLIS, which meets at the Library of Congress.

The header format being developed by the NCLIS/NBS Task Force on Computer Network Protocol, at the time of this paper (June 1977), is not

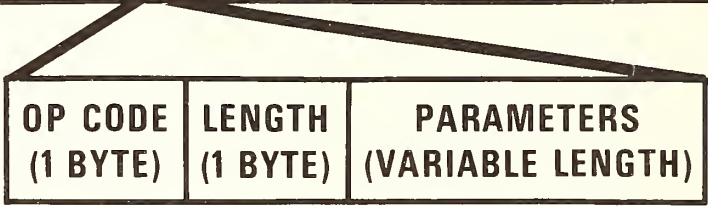
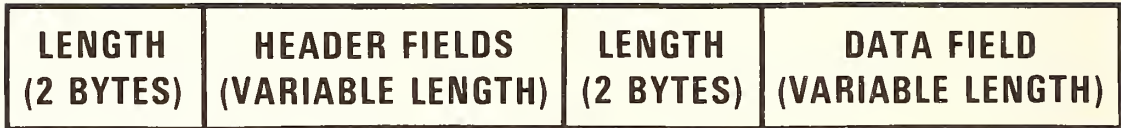

SOURCE/DESTINATION ADDRESS

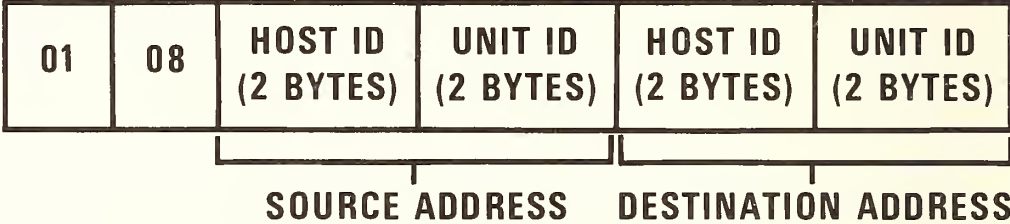

FIGURE 5.

Message structure

SOME HEADER OP CODES

- | | |
|----------------------------------|--------------------|
| 1. SOURCE/DESTINATION
ADDRESS | 6. DATE |
| 2. REPLY ADDRESS | 7. TIME |
| 3. BILLING ADDRESS | 8. DATE/TIME |
| 4. BULK REPLY ADDRESS | 9. PRIORITY |
| 5. SEGMENT | 10. TIME LIMIT |
| | 11. RESOURCE LIMIT |

FIGURE 6.

completely developed. At the time when it is fully defined (expected date: September 1977), the format may become a proposed American National Standard. However, it would seem more prudent to gain some operational experience in its use and capability before proposing it to become a standard for use in library and information service networks. The final report of this Task Force will be submitted to the American National Standards Institute, the American Library Association and the American Society for Information Science as well as to other relevant organizations. Thus, the protocol developed for library use may be one of the first protocol standards at the application level developed by any community of specialized interest.

Reference

Cotton, Ira W. Computer Network Interconnection: Problems and Prospects Washington, U.S. National Bureau of Standards; for sale by the Supt. of Docs., U.S. Govt. Print. Off., 1977. (NBS Special Publication 500-6).

Telecommunications and the Expansion of Information Services

by

Stuart L. Meyer

Telecommunications can expand information services in libraries. We shall also see that telecommunications techniques can address some problems facing libraries. Telecommunications techniques can allow institutions to become more cost effective by better sharing of resources among the various institutions and by serving a wider population of users (hence, distributing whatever costs exist among a wider class of customers). Further, telecommunications can make expensive resources available to scholars wherever they may be: in remote locations, hospitals, and so forth. They can provide greater opportunities for professional growth and training of the library staff.

The technology for the systems I will be proposing already exists. A cooperative effort among libraries is necessary to achieve it. Libraries represent a special interest group; libraries themselves are a network of information centers.

The technical concept that underlies my vision of using telecommunications techniques in libraries is a coined phrase, controlled-scan televideo (CSTV). Slow-scan television (SSTV) was the first version of it. Controlled-scan is used because, for efficiency, you match the rate of transmission of information to whatever channel you have available. Televideo implies the transmission of (stationary) visual information over a distance; it is distinguished from television, which usually implies motion.

What are the problems facing libraries that telecommunications techniques might solve? The major problem is an uneven allocation of resources. Sharing resources is clearly the only way to go. Another problem is that library staff do not fully utilize their professional skills. They need to be motivated to advance professionally. A staff development program could improve both morale and productivity. Next, we need an efficient document delivery system to match our fairly sophisticated data base search systems. I think we must avoid, wherever possible, the U. S. Postal Service as an efficient means of document delivery. Finally, any system we devise must accommodate the new copy-right laws.

With a telecommunications system we should be open to change both in the present format of the printed page and in the printed page itself. Laboratory psychologists have found that the single column, in which American books are frequently published, is too wide for efficient

Dr. Meyer is an Associate Professor in the Graduate School of Management, Northwestern University. This paper is condensed from Dr. Meyer's presentation.

reading. Even book formats should be reconsidered. Unless you like the tactile feeling of turning a page, there is really no reason on technical grounds to propagate that particular format in a future system.

There are certain principles that should be adhered to in developing any telecommunications system. The first one is, "There ain't no free lunch." Everything costs. Then, there is the Principle of Sufficiency, which states that there are certain minimum functions which have to be served by any system. There is also what can be called the Principle of Minimality, or the Principle of Economy, which says, "Do not do more than you have to do!" "Waste not, want not" is in much the same spirit as the Principle of Minimality or Economy. We want to take what we have and use it to the fullest. A parallel philosophy is what I call "parasitism." If you find that somebody else has already solved a problem, maybe you can cast your problem into a form that will fit that solution. Don't do the work twice. Finally, in the specific technological situation that we'll be talking about, let me make two judgments. I think it is okay to generate specialized electronic devices for relatively specialized uses like libraries--but not electromechanical devices, unless you can utilize technology that was developed for the consumer market. If someone makes 100 million electromechanical devices, they will probably work. But if you only make 10,000, there probably will be maintenance problems.

A recent report of the Librarian of Congress, Daniel Boorstin, stated that the whole point of library work is to put the needed object, book, periodical, map, recording, or its intellectual substance, into the hands of the user. You don't have to give the very book that you have in the library to someone, just its intellectual substance. I like this quotation, except I would substitute the mind of the user for the hands of the user. Another worthy quotation by Dr. Boorstin is, "Are our collections as widely and fully used as they ought to be? No indeed." This quote addresses some of the principles we discussed earlier and represents recognized problems.

We have certain expectations of libraries which must be taken into account in considering a telecommunications system. We expect certain materials--books, journals, reports, audio-visual and computerized systems. We expect certain services--bibliographic searches, reference interviews with librarians, teleconferences, staff development, and a document or materials delivery system.

We also expect different functions of libraries that communicate with libraries and libraries that communicate with users. Their needs are different, their volume of traffic is different, their need for access time is different, and their communications channels should very likely be different. In developing a telecommunications systems, we want to match communications channels or distribution channels to the needs of the particular user.

Before describing a system, let me define some terms. We all know what real-time systems are; they are systems that produce information

almost instantaneously. In quasi-real-time information does not arrive instantaneously, but it arrives fast enough. The distinction between real-time and quasi-real-time should be emphasized. For example, I might request a book at five o'clock, and then go home. It does not matter to me if that book does not arrive until eight o'clock the next morning.

Interactive is also a very important concept. Fully interactive means that the sender and receiver are constantly changing each other's presentation or information flow. In a quasi-interactive mode, you cannot alter the presentation, but you can modify it. Reading a book exemplifies a quasi-interactive mode: you can skip pages, you can underline things, you can cross things out, and you can make corrections; you are not fully interactive with it, but you do have the ability to modify the presentation.

Now we come to a distinction which I would like to emphasize; it is one of these very simple, almost trivial ones which, in many contexts, is overlooked. That is the distinction between machine-readable information, which a computer can process, and machine-accessible information, which a computer can call up for you but cannot manipulate. If you want to read a page, it is not necessary for your purposes that the computer be able to read and understand that page. It might be sufficient in many cases for the computer to be able just to direct the system to present that page to you. Once you realize that, you find that you do not have to get all materials into machine-readable format.

Hard copy, we all know, is a piece of paper in front of you or a bound piece of paper. Soft copy is information in permanent form for as long as you want it, which you can call up on demand. For example, a book page which is stored on magnetic tape is what I call soft copy. I can look at it whenever I want, I can keep it for the next twenty-five years, or I can erase it tomorrow. A transient display, for example, is information on a TV set, viewable for as long as you want, but irretrievable once you turn it off.

Any kind of information, audio or visual, can be transmitted across telecommunications channels. From an economic point of view, the utilization of telecommunications channels involves two factors, bandwidth and the time you utilize the channel. Bandwidth, in a digital sense, tells you how many bytes per second you can send; in an analog sense, it tells you how many hundreds of hertz or cycles per second you need to utilize. The narrower the bandwidth used, the longer it will take to transmit the information. Conversely, the wider the bandwidth, the shorter the time necessary for transmission. Examples of narrowband channels include the telephone or the AC power line in your house. Wideband channels include satellite channels, TV channels, or cable TV channels. Thus, we have two modes of operation: one we call a narrowband-channel mode, where we are using a channel such as a telephone line for a longer period of time; the other is a broadband channel or frame-snatch mode, where we use a satellite channel for a shorter period of time. We can divide up a channel for efficient utilization.

The narrowband mode is then called frequency division multiplex (FDM); the frame-snatch mode is called time division multiplex (TDM).

Broadcast TV, the picturephone (about which I have nothing but bad things to say), and controlled-scan TV have different information-carrying capacities or frequency bandwidths. In the slow-scan TV mode, CSTV uses the telephone line. The ratio of the information-carrying capacity of TV, picturephone, and telephone channels is 1000: 300: 1. You can send the same amounts of information over any one of them. It just takes you different amounts of time to do it.

SSTV, which sends only still pictures, actually has some advantages over television. You can, in fact, vary the resolution using the same telephone line. Basically, resolution is the ability to discern detail, to see fine print or to see a larger or smaller number of characters. If you want to send a higher resolution picture, it obviously takes you longer. SSTV also has a gray scale capability for reproducing half-tone photographs. The gray scale is frequently encoded as a certain number of bytes of information. However, if you do not need it, do not use it. That goes back to the Principle of Economy I mentioned earlier.

To transmit information I can also use an FM channel or something called Subsidiary Communications Authorization (SCA) channels. They are frequency bands which are piggybacked on every FM station, one for multiplex stereo stations and two for monaural. In Chicago, some ethnic stations that cannot afford an FM station use SCA channels; a medical service also uses them.

We have been talking about transmitting video information. We can also transmit audio information or combinations of video and audio information. Obviously if I wanted to encode sixteen seconds of audio, I can transmit it over the telephone line in sixteen seconds. That is not difficult to understand. What is interesting is that there is a system on the market, VIDAC, developed by Westinghouse, that can encode sixteen seconds of audio as a video frame. Thus, you can use audio technology to send pictures or picture technology to send audio.

Another example of telecommunications technology is the Remote Blackboard, developed by the Bell Telephone Laboratories. It displays the blackboard on a TV set and is useful for some kinds of teleconferences. Reasonable people might ask why the overhead projector is not used as a model instead of a blackboard. Nevertheless, it does indicate that we have the capability of sending pictures with camera format for teleconferences.

The systems and technologies I have described can be applied to the library services we previously talked about--reference interviewing, teleconferences, training, data transmission, and document delivery. I am going to concentrate on the use of telecommunications for teleconferences and document delivery in libraries.

If a teleconference system were set up in a library, what features would you want to have? You would like to have a camera input that could focus on people and objects, such as books, documents, a black-board or an overhead projector. You would like to be able to freeze the picture or frame, so that a person would not have to sit still for sixty seconds, store the picture, and then send it. Finally, you would want to use a TV for display. It is a very economical display device and is readily available.

What features would be important in a document delivery system? First you would want flexibility in the format. You would want to be able to transmit information from any size materials, bound or unbound. You would want the gray scale to show photographs. You would want to be able to vary the resolution. (You may be interested to know that PROJECT INTREX at the Massachusetts Institute of Technology (MIT) actually measured the kinds of resolutions in TV lines that you need for transmitting different types of material. It found that English text requires 1200 lines, Japanese text requires 1400 lines, while almost anything to be found in a library can be resolved with 2000 lines.)

In order to have all materials available for a document delivery system, it will be necessary to restrict access to the permanent collection. This restriction addresses one of the problems in libraries of which some of you are aware, namely, the inability to find materials. It is called the "not on shelf" problem in some quarters. Further, we want our system to reduce the fetching operation by trained professionals. With the document delivery system I will propose, we can reduce that fetch to one instance. We also want to store materials in a manipulable form. Use whatever electronic storage medium is economical at the present time. Do not hold out for the most dense, the most economical, the most effective system which will be available 20 years from now. Once your materials are in a manipulable form, you can always convert to whatever new form of storage presents itself on the horizon. Storage of information will eliminate the need to keep going back to the shelf for it; it will be retrieved once and stored for future requests. I suggest you use some kind of magnetic tape for a large library like the Library of Congress. I do not believe in the future of magnetic tapes without reservation, but once it is in magnetic tape form, it can be converted without using a lot of labor. I can use computers to do the conversion and computers work 24 hours a day. Further, I can manipulate it into other forms.

Our document delivery system must also take into account the new copyright laws. You are going to have to keep records of the number of times a certain material is accessed. I think the best thing to do is to automate access and records of such accesses. When the publisher wants to know how frequently the materials are used, you can tell how many times they were accessed, and you strike an agreement and pay a fair price.

The Principle of Minimality suggests that we distinguish archival quality, which is something that a library should be proud to have in

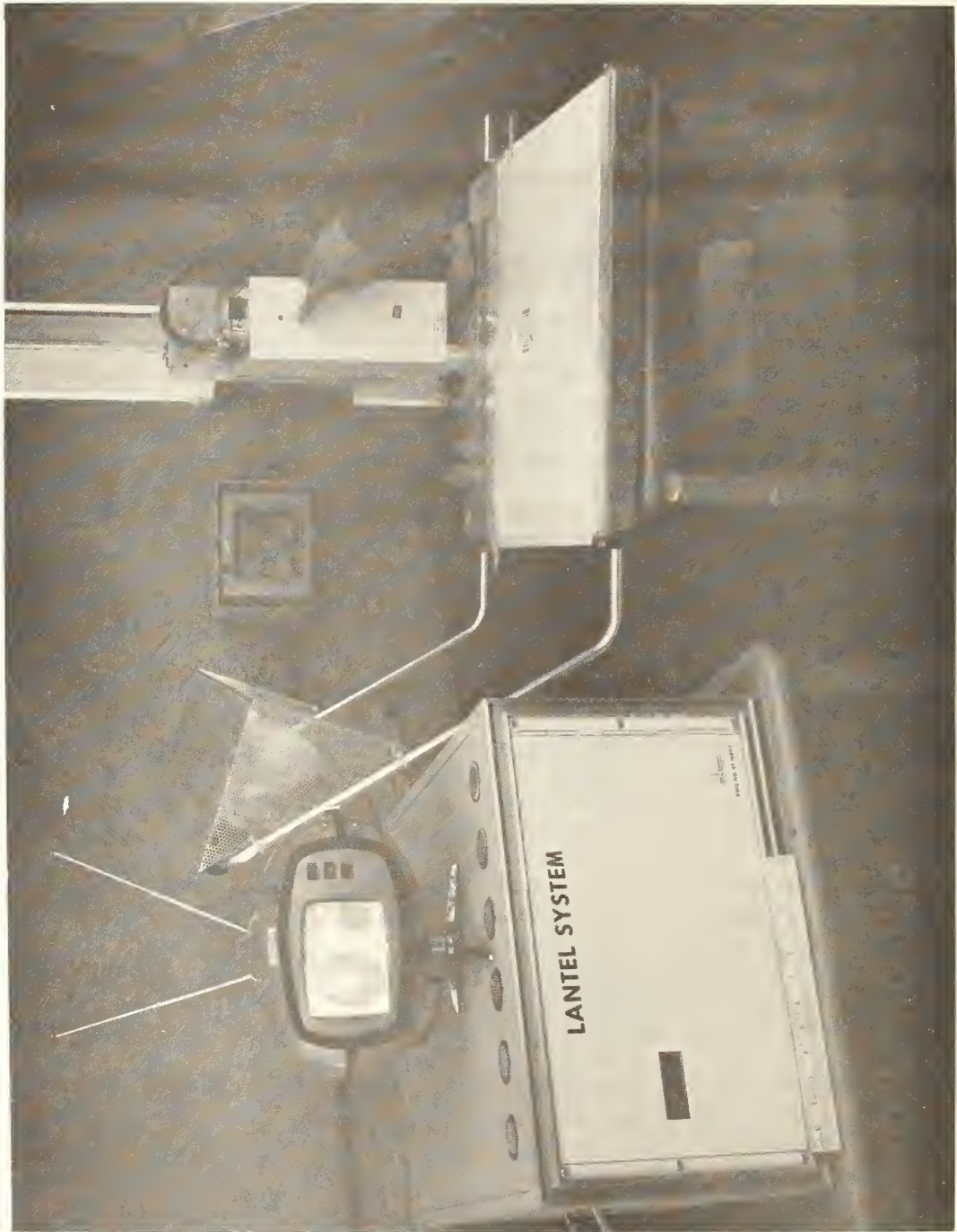

Figure 1. The LANTEL system

its permanent collection, and usable quality, which is all somebody needs for perhaps a temporary use in our document delivery system.

Finally, we should consider output formats easiest for people to read. Studies indicate that forty characters per line is easiest. It is what the Wall Street Journal and the New York Times use. Interestingly, you can display 40 characters per line on a TV set--even a poor TV set.

What is the present sequence of events for library access? First, there is the reference interview and the data base search. We do that very well. Then, you have to identify the material you need. Here begin the problems. Usually you do not have the abstract of it nor do you have the table of contents. You do not have the ability to browse to see if you really want that stuff. Then, once you do know what you want, you have to locate it. Now we come to the real problem. Half the libraries in the country, I am told, cannot even tell if a book, which is in their card catalog, is anywhere in the library. The libraries that can tell have, nevertheless, what is called the "not on shelf" problem. (My solution, of course, is to keep the book there all the time and just make copies, not in a Xerox form, but in some form of machine-accessible storage medium.) If the book is not in the library, then you have to order it. Interlibrary loan means that you ask for the book, or ask for a photocopy, or you ask for a fiche copy. And then comes the fun. You wait for the U. S. Postal Service to do its thing, and you wait and wait and wait. One of my colleagues at Northwestern refers to "twentieth century bibliographic search techniques and medieval delivery systems"; he is very right.

CSTV could be used in libraries for teleconferences and as a document delivery system. The system has been on the market for a long time; it is what I call a retrograde technology, which is at the moment very cheap. As I mentioned before, you can show pictures or type with at least 40 characters per line. You have a gray scale capability. We used CSTV to teach students who were three blocks away. Motorola's Engineering Research Laboratory in Schaumburg, Illinois has used it to provide continuing education to its professionals. It has one major disadvantage: you must drive to the campus for the course. If it takes an hour to drive to the campus, and an hour to drive back, you use three hours of time for each hour of instruction. If an engineer's time is worth thirty dollars an hour, one class hour will cost ninety dollars. That is a lot of money.

Can we teach people off campus? Can we do teleconferencing at a distance? We did some experiments in teleconferencing to show that this kind of thing can be done. There are other examples too. A medical conference was held between Northwestern and Balboa Naval Hospital in San Diego. Figure 1 shows the LANTEL system that we built some years ago with a completely solid state memory. The little camera unit, which is the transmitter, made it up to the Arctic Circle and down to Guadeloupe Island to watch a volcano blow up. The picture is displayed on a 65 dollar TV set that was not modified in any way. We bought it at a



Figure 2. Picture resolution using the LANTEL system

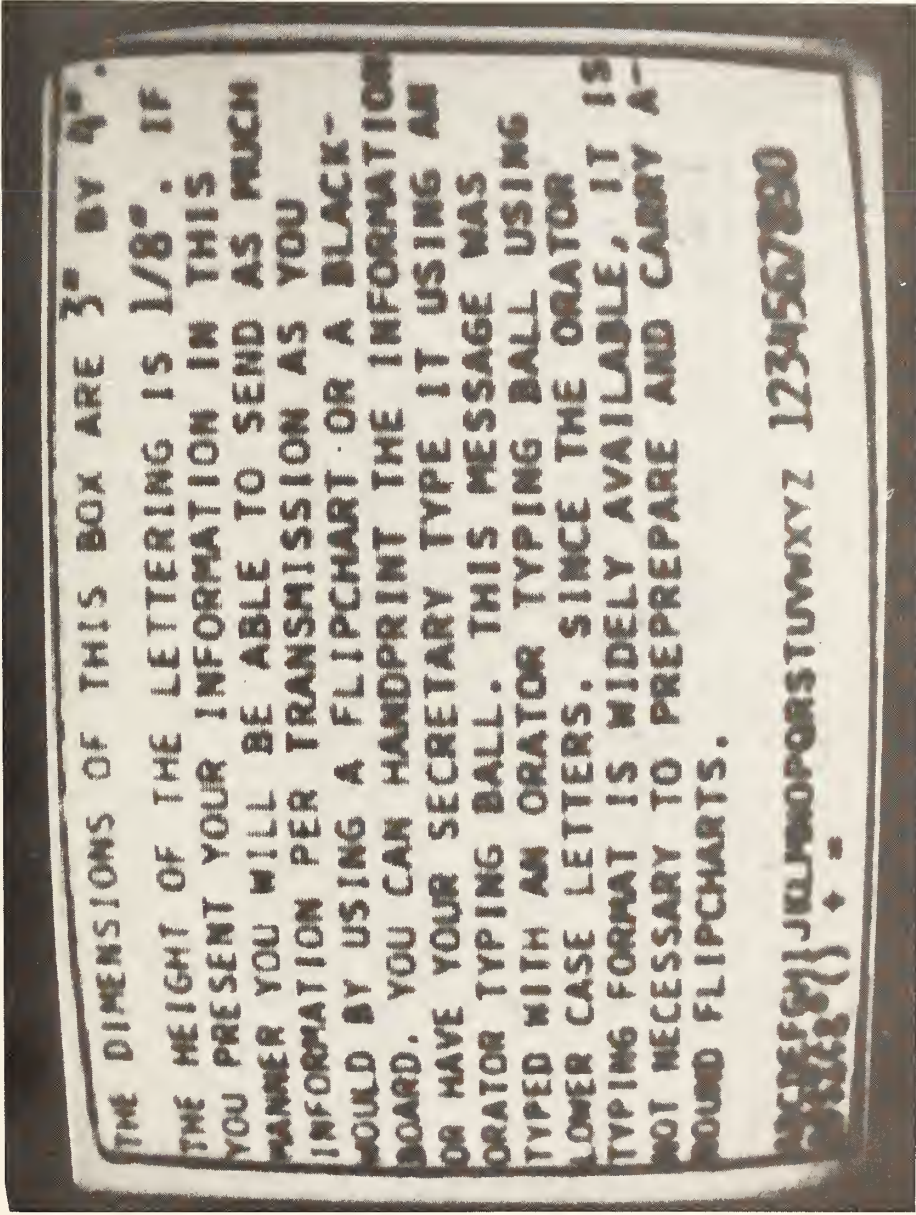

Figure 3. Text resolution using the LANTEL system

discount store in Los Alamos, New Mexico. The whole system is contained in the box labeled LANTEL. Basically, the idea is that if you have a telephone link going anywhere and you have a television set for whatever reason, even to watch television, all you need is a black box that will assemble the information in pieces over the telephone line, store it up, and then spit it out at video rates for a stable display on your TV set. Once it travels over audio lines, of course, you have the full spectrum of devices which have been developed for audio links. You can manipulate the picture electronically; you can store it on audio cassettes. (Audio cassettes are acceptable electromechanical devices because Norelco has built a couple hundred million of them.) Figure 2 shows the resolution for pictures and Figure 3 for text. It is a lousy system with 250 line resolution because we did not have enough money to build enough memory. But it has been working since July 1974, and it has the capability of showing forty characters per line. (Remember I told you the INTREX study indicated that text really requires 1200 lines.)

Figures 4, 5, and 6 diagram the production and storage, distribution, and display stages of a telecommunications system designed for a network of primary, secondary, and tertiary libraries. Primary libraries are the main sources of certain kinds of information. Even small libraries can be primary libraries with respect to certain collections.

How does the system work? What are we going to do the first time somebody wants a library material? Well, we have to send the fetcher and hauler to get it; I cannot eliminate that first time. However, instead of making one Xerox copy of it for the user, we film it using a high resolution television document camera (Figure 4). (Cameras have advantages over FAX machines.)

At this point, let me tell you about a commercial system on the market, made by Ampex, called a Videofile, that can scan 1280 lines. Once the text is filmed, you can transmit it, transfer it to cassette tapes, or store it using the Videofile which has a 1200 line resolution. There is a control unit. When there is a request for a material, it is retrieved and a copy is always made for the video file on the sheer chance that some second person might want the same material. That is the crucial step, which saves the fetching operation for accesses two through infinity. This system can store 166,000 pages on about a 12½-inch diameter by 2-inch reel. There are other ways of doing the same thing. Patent number 3,803,350 claims to have a cheaper way to store high resolution. The important point is that one can produce material on magnetic tape with very dense storage which is, at least, machine accessible. If, later on, it turns out not to be so cheap, you can switch it into a cheaper format.

How do you distribute it? (Figure 5) Well, you can make audio cassettes and mail them out or take them home. Or you could take the information from an audio cassette, store it in a buffer, and send it out to a TV set or make another cassette copy of it. Or you could

PRODUCTION & STORAGE (PRIMARY/SECONDARY)

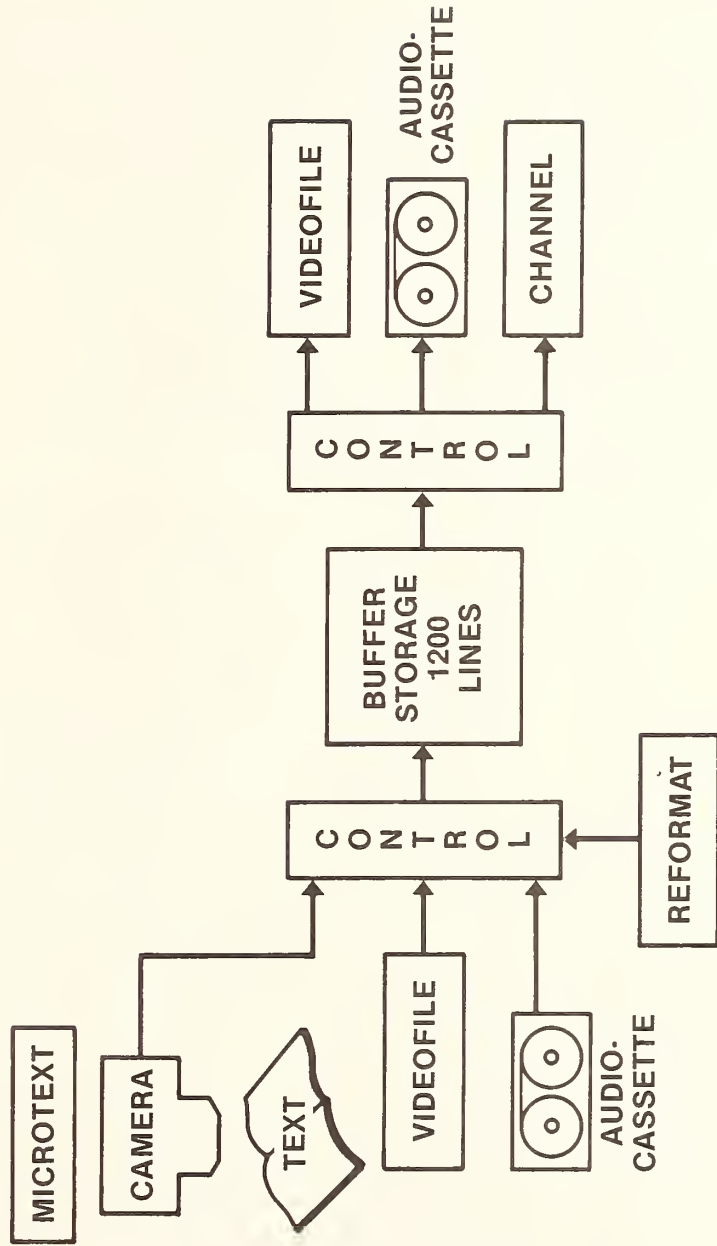

Figure 4.

DISTRIBUTION

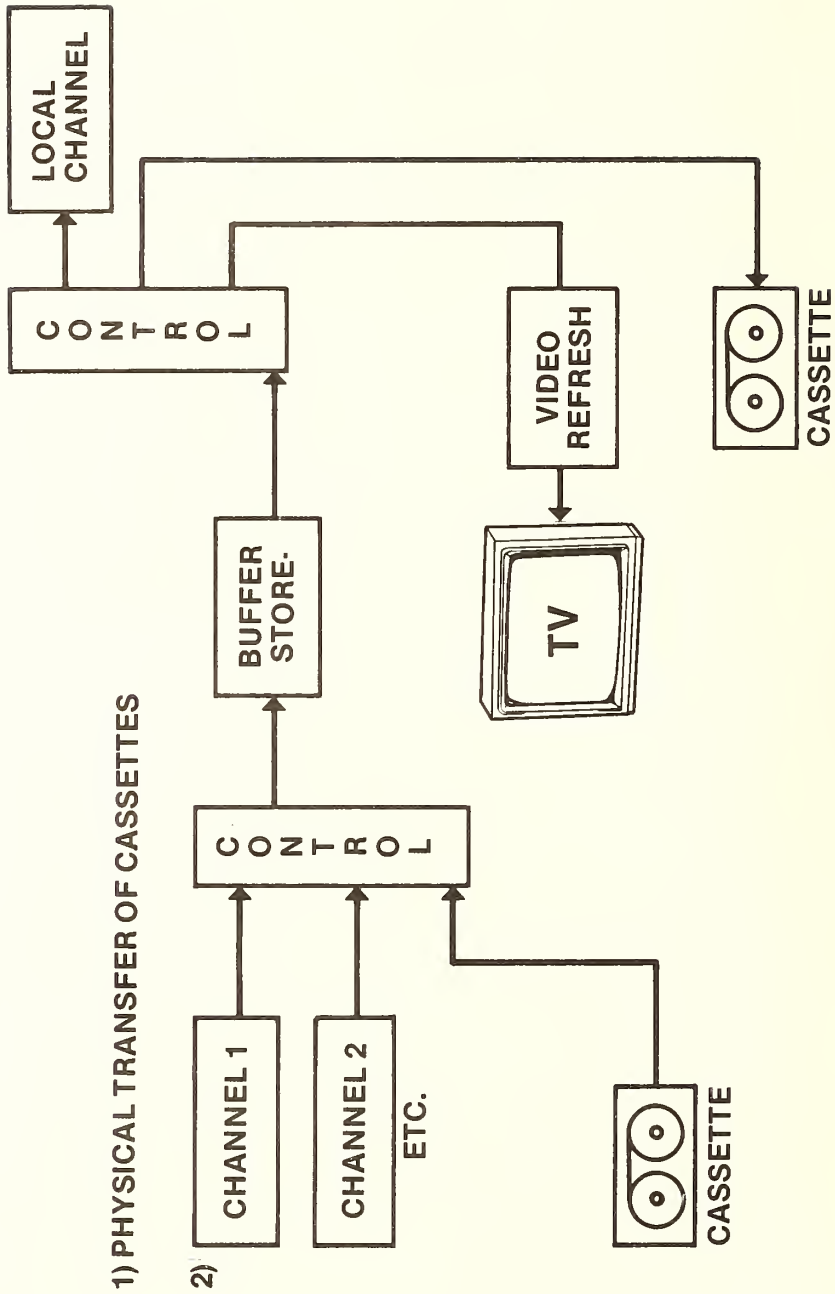

Figure 5.

DISPLAY

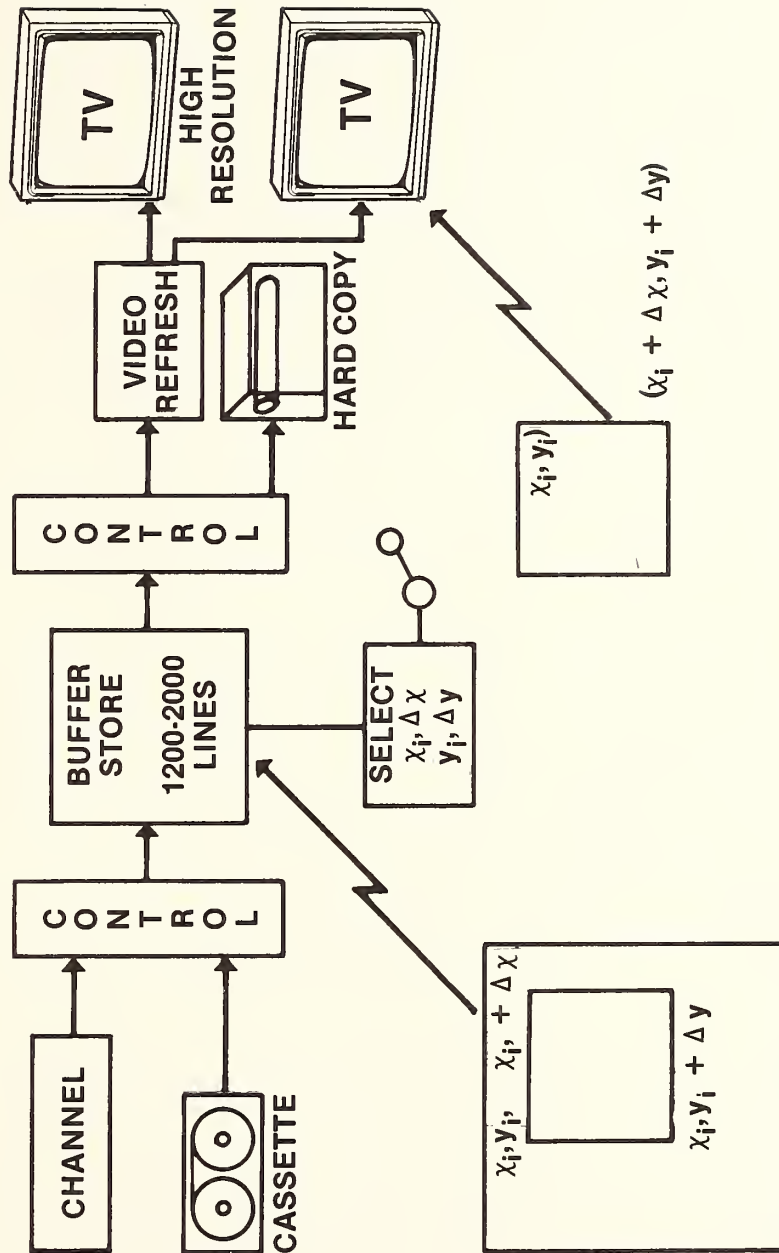

Figure 6.

transmit the information using whatever channel is available--a telephone line, a TV cable, or, if there is enough traffic volume, a dedicated line, a satellite channel.

Figure 6 shows what the display unit looks like. Here I have an audio cassette and a channel going through a control unit to a buffer. This system can display more than 500-line materials on a 500-line system. But it is not necessary. With specialized TV devices, you can go all the way to the right on the diagram where it says TV high resolution. Libraries can probably justify having high resolution systems. The Ampex Videofile system has, in fact, a whole bunch of special TV sets. An interesting point is that you might even be able to reach people in their homes and use ordinary TV sets. Library people tell me that users my age or older "need" hard copy. I think this will change. My feeling is that you get cluttered up with paper rather quickly, and even though we have to provide the capability for the transition period, I predict that it will fall into disuse, except for certain applications. As an example of release from the constraint of hard copy, 600 pages of text can be stored on an ordinary audio cassette.

Uses of Teleconferencing in Crisis and Warning Situations

by

Thomas G. Belden

Back in the Dark Ages when I first joined the Institute for Defense Analyses, I think it was 1962, Jerome Wiesner, who was then the science advisor at the White House, came to us with a problem. He said suppose there were a crisis in NATO and there was not enough time to get the players together physically, how would you wire them together? Although it sounds like a simple question, it is rather complicated because NATO consists of 16 countries that speak 11 different languages, two of which are official. Dr. Wally Sinaiko and I first conducted a literature search to find out all about teleconferencing. Either there was a "not on shelf" problem or there wasn't any literature--we never knew which. So we did something that we were not supposed to do at IDA; we ran some experiments of our own. We found five rooms underneath the Hot Shoppes on Connecticut Avenue and wired them up in various ways. When we began to compare actual differences in media of communications under various conferencing task conditions, we found a lot of our preconceptions, such as "broader bandwidth is always better," were destroyed. We were aided in this experiment by the excellent consulting services of Dr. Jerry Kidd. We did a lot of work together on various types of display conferencing as well.

Well, let's make a great leap forward, and I will tell you about the awful environment in which I work now; it is one in which you can only lose--it is the warning and crisis business. I would like to give you a little background as to why this is a peculiar problem and why teleconferencing is key to a part of the solution, we hope, to the problem. I would like to mention some of the things that we are doing today. In the audience today are Nate Fitz and Tom Yingling, my current colleagues, who with the help of Jerry Kidd (University of Maryland, College of Library and Information Services) are trying to improve communications across some very thick bureaucratic barriers in the Government in a very quick time situation.

First, let me tell you what I feel is the primary objective of intelligence in warning and crisis operations. Everybody does not agree with it, but it happens to be our point of view. The primary objective of warning is crisis avoidance, within the limits of our national policy. If you cannot avoid a crisis, the next best thing is to manage it to satisfy national policy objectives without resorting to military force. If you cannot do that, use conventional military force and diplomatic efforts to avoid long or severe conflict, conventional or nuclear. If that fails, end the conflict on terms as favorable to our interests as possible and before Armageddon.

At the time of the Conference, Dr. Belden was a member of the Intelligence Community staff.

What do we mean by the word warning? Everybody has a different definition of it. To me, warning implies decisions and actions. For instance, to residents in Washington, D. C., a radio bulletin that tornadoes are going to hit Topeka, Kansas at six o'clock this evening is an estimate or a forecast. However, if you live in Topeka, Kansas, it is a warning because it implies that you have to make some decisions to take action. If you look at warning from that point of view, warning becomes a process and a rather complex one.

The warning process starts with indicators; there can be military and nonmilitary indicators, including economic, political, and so forth. Indicators can be long term, mid term, and short term. Now the problem of intelligence is to converge all of these indicators, regardless of what they are, to make some sort of an analysis. The analysis then generates the decision; the decision then generates an action; the action that we take, wittingly or unwittingly, becomes a potential indicator to the other side. And they do the very same thing that we just did. They make an analysis, make a decision, and take an action, which becomes a potential indicator to us. Thus, it is a process. These cycles can be years long, months long, days long, hours long.

Unfortunately, our government is not organized to meet the demands of the warning process. Some major bureaucratic barriers exist, particularly between the analysis and decision functions (the intelligence community and the policy and decision makers), and between the analysis (intelligence) functions and the world of the action functions which are the responsibilities of the Joint Chiefs of Staff and the various U.S. Unified and Specified Commanders. Communications across these barriers is very, very difficult in our government. We are going to talk about how we are trying to break down these barriers with improved interagency communications.

The warning process is cyclical, being generated by the actions emanating from opposing decision makers. What you do affects what he does, and what he does affects what you do. This phenomenon of interaction has profound implications upon the concept known as intentions.

Whenever a nation is contemplating a major political-military action against another country, it has to go through a series of steps. As one ascends the steps (figure 1), the probability of war increases. At the bottom of the steps, or before an action is considered, there is zero probability of war. As each step beyond the initial action is taken, the probability of war increases. At any time, however, decisionmaker B might take an action which alters the situation in such a way as to cause decisionmaker A to change his mind, back off, and go down the stairway, away from hostilities.

At the bottom of the stairway, the national decisionmaker must be aware of his own capabilities (and limitations), of what he can and cannot do. Once he feels threatened by another nation, he begins to figure out what his political options are. He must then examine contingency

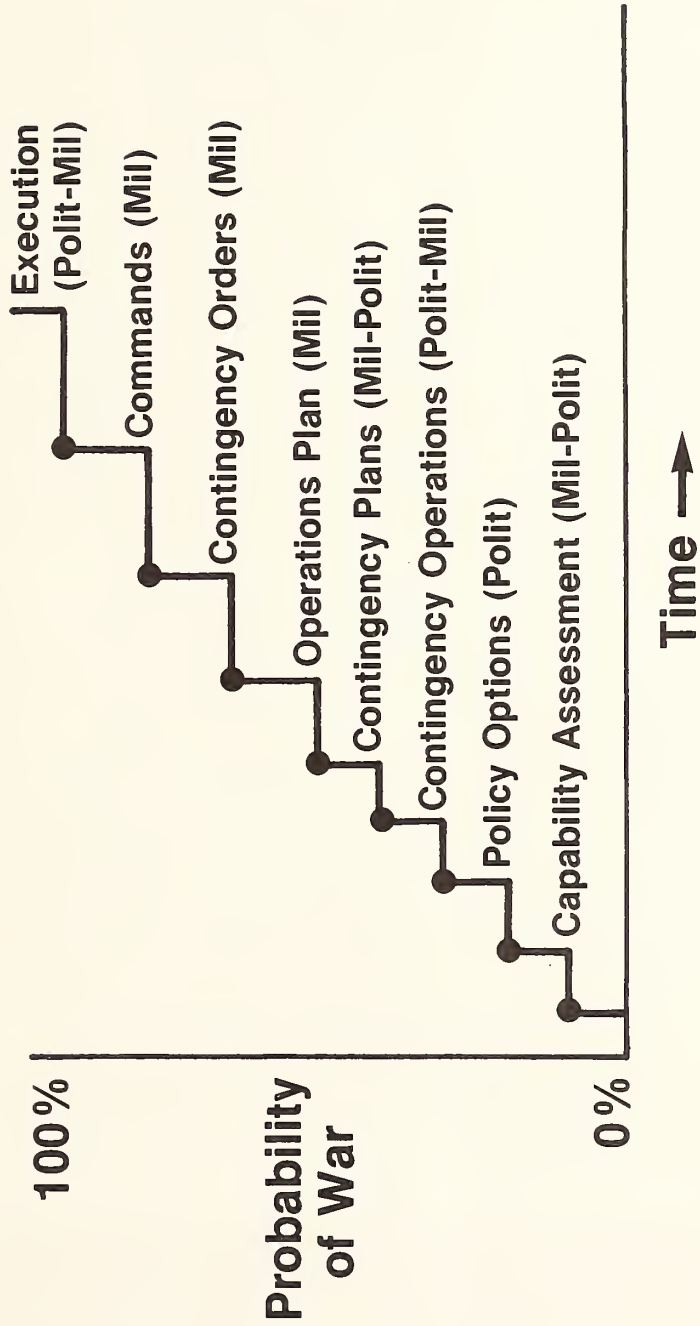

Figure 1: Decision Stairway

options and plans and, if the threat continues, move up the decision staircase with operational plans, orders, commands, and finally, execution. But, in this process, the opponent can sometimes do something to make the other man change his mind and go down the stairway.

Let me give an illustration of the decision stairway in the events leading to the attack on Pearl Harbor. In the late 1930s, the Japanese attained the capability to dominate the Western Pacific. However, they were also engaged in a war with China, which antagonized us. We imposed certain economic sanctions on Japan and that irritated them. They responded with contingency options and plans which, after we imposed an oil embargo, caused the Japanese to begin to plan the attack on Pearl Harbor. We were still eighteen months prior to the event. Negotiations were going on between the United States and Japan while Admiral Nagumo, the Japanese task force commander, was moving his fleet across the North Pacific to Hawaii. On the second day at sea he opened the sealed envelope which contained orders for him to attack the U. S. Fleet at Pearl Harbor if two conditions were satisfied: 1) the U. S. Fleet was in Pearl Harbor, and 2) he could achieve surprise. But the final decision as to whether those conditions had been achieved was left to Admiral Nagumo; he was getting that information from his intelligence network in Hawaii. He was under additional orders that if, by chance, he was detected by the U. S. Fleet, even though he was only one day out from Oahu, he was, in effect, to go on deck, bow politely, say that his task force was on exercise and bring it back to Japan.

If we had had a good warning system, so that we knew of Nagumo's task force, and if we had been sophisticated enough to let the Japanese know that we knew they were approaching Pearl Harbor, then Nagumo would have been deterred from attacking. Let me ask you what could have been said about the Japanese intention to attack Pearl Harbor? The word intention is a very slippery word. Intentions are always buried down underneath as options, but you cannot say with certainty what the other man is going to do until he gives the final command to execute. I am afraid that I am trying to destroy the romantics' James Bond school of intelligence, where the agent comes in three weeks before Pearl Harbor and takes out from the heel of his boot a message that the Japanese are going to attack Pearl Harbor at 7:57 on the seventh of December. No way. The Japanese delayed the intention to attack as late as was feasible, using the standard decision technique of keeping one's options open as long as possible. This is the pattern in crisis situations. It is what makes intelligence so difficult, because every prediction has to be made in a probabilistic fashion. There is no certainty in this business.

The important point is that the best any intelligence system can do is to determine where the opponent is on the decision stairway. Let us consider the information that has to be converged to construct the stairway. At the time of Pearl Harbor, you had essentially three intelligence organizations, the FBI, the Army's G-2, and the Office of Naval Intelligence. At the end of Korea, there were more intelligence

organizations. And at the end of 1969, there was an even greater proliferation of agencies. I am not being critical of any of these organizations because they all do excellent work. The problem is how to converge the critical, relevant information when you have so many organizations to deal with. It gets exponentially more difficult because you are going to have more and more data, and the greater the volume of data, the less likely it is that you retrieve what is germane. Now I have not drawn the current chart, first, because before it dried, it would be changed, and second, because I want to keep my sanity for another year. Whenever the Government faces a problem of this kind, the panacea is either to reorganize or to establish a new organization. In fact, we are going through that right now. There is so much turmoil that when we leave our offices, we say to the secretary, if the boss calls, get his name.

Four years ago I was loaned to the intelligence community and I have not had any time off for good behavior. What I did was to lay out the various kinds of crises in terms of the time constant, that is, how much time do you have to deal with them. For example, shooting down an EC-121 is a very quick crisis, virtually unpredictable. The Cuban missile crisis is days or weeks long. An energy crisis creeps along over many years. Now for longer kinds of crises, you have lots of Government structure, all the way up to the President, dealing with them. But for the shorter, quicker crises, you really do not have anything. Here is this great big blank and the first temptation is to reorganize to fill it. This time we decided not to reorganize, but to fill that gap with something new and different. We decided to take advantage of the current organizations that we have, but have them communicate with each other in some new ways that they have never done before.

We set up a conferencing system called the National Operations and Intelligence Watch Officers' Net (NOIWON), which allows the operation centers of CIA, DIA, NSA, State, State INR, J-3, and the White House Situation Room to call a secure voice conference at any time. It is a dedicated net so that the minute a critical message comes into any one of these places, it can be passed on to the other six operations centers.

You will notice we included in this network not only intelligence agencies, but also the operations side of the military and the State Department. This was very critical because it provided a way to break down barriers among bureaucracies. To establish NOIWON, it cost only 50 dollars to put five toggle switches on a telephone at NSA and it took only two weeks to install the necessary equipment. But it took 10 months to make it operational because of the cultural differences among these people. "CIA people do not talk to J-3 people," and so forth. However, by exercising the net for 10 months, and with lots of hard work on the human side, we finally convinced everyone of its usefulness. You could not tear the system out now. I mean they use it too much! They use it four times an hour during a crisis. It is established and going.

All ideas go through what I call a three "0" stage. First they are Outrageous, then Obvious, and finally, Obsolete. The NOIWON is now in the Obvious stage. Our other idea is still in the Outrageous stage. When you are in a crisis, you need to get the smartest people in town who know about that part of the world. If it is a Lebanese evacuation, you need people who know the downtown streets of Beirut, and all the roads. You know these people exist. The problem is to be able to reach them no matter what part of the government they are in. We propose a human retrieval system, a computer which does not give you data or references but gives you names and telephone numbers of people who are smart about certain things. We are trying to promote this under the name of MYCROFT. We named it after Sherlock Holmes' elder, smarter brother who used to be the great converger of information on the British Empire; he would brief the Prime Minister every morning about the state of the world. There is no such person, of course, but we think that collectively a lot of people could perform this function.

Once you find out who the people are, the next step is to give them a conferencing capability as well. If this group includes operations and intelligence people, we felt they should have a bit more than just a secure voice speaker phone. What we have done is to create what we call a CONTEXT system in five locations: one at the State Department to be shared by the operations people as well as the intelligence people; one at CIA for the DCI, the CIA, and the National Intelligence Officers; one at NSA; one at the Pentagon; and one at the new headquarters of the Intelligence Community staff on F Street. These rooms are connected together by a secure voice conferencing net which terminates in very high quality speaker phones. If we had one here on the table, you could hear it all over this room. Thus, you can have very large conferences in each room, which can be connected throughout the intelligence community. The CONTEXT rooms also have a mini-computer, keyboard, an auxiliary memory unit, a hard copy printer, and a large CRT screen like the kind used in airports to announce flight arrivals.

The object in planning these CONTEXT rooms is to imitate what people would do if they sat around a table to write a situation report-- because that is what happens in a crisis. During a crisis, the President demands a situation report every two hours. We do not want people piling into their cars and driving an hour to get to some location to have this conference. We want them to be able to go to the CONTEXT room at their own agency, where they have access to the information they need. When a crisis occurs, somebody usually prepares a draft statement. With CONTEXT, this draft can be put into the auxiliary memory of the mini-computer. When the conference is called, the chairman will have everyone take a hard copy of the draft from the printer. The chairperson can then ask the operator to put the first paragraph on the CRT. Changes in the text can be discussed on the speaker phone system and adopted. The group then proceeds, paragraph by paragraph, through the statement. When discussion of the draft is completed, the mini-computer, with automatic editing routines, can print it immediately.

This system, of course, is no panacea. You have to be very careful when you give the community a tool of this kind. One of the things you do not want to do is design a system that will permit people to make stupid decisions faster; therefore, in the procedures, you have to provide for dissenting views.

There are many different systems that can be brought to bear in this problem of crisis and warning. I do not want to give you the impression here today that we have done anything that is any panacea. But, if we could improve our batting average by two percent, it would be worth the effort.

However, the basic problem remains: given all the improvements in physical communication, what do people have to say to each other? How precisely do they say what they mean? One of the most difficult forms of precise expressions is making warning statements in probabilistic terms.

The decision stairway can be expressed in terms of time and probability. This requires that warning must also be expressed in these terms. The minimum expression of an interactive warning estimate must be in the form:

There is a ____% probability that A will act upon B by ____ (when).

There are many possible variations on this statement. First, probability can be expressed in terms of words, including auxiliary verbs and adverbs (might, might possibly, probably, and the like). Unfortunately, such expressions convey different meanings to different people. The uses of numbers (20%, probability, 3-to-1 odds, 4 chances in 10, and the like) are not without difficulties as well, particularly when used with false precision (e.g., 23.2%), but they do have the merit of internal consistency. Further, the choice of the number itself is not as important as the change over time of the number on a given estimate.

In making a probability statement, one must always keep in mind what one's own actions might do to the prediction. This holds even if one is not one of the two opposing parties. Some remarks should accompany the probability statement giving the assumptions regarding these potential interactions.

At any given time, an analyst might write several warning estimates related to the situation. This will allow him to review the estimates periodically and record any changes in the probability and the reason(s) for the change. The changes can be used to "take the temperature" of the situation. To do this, one must use precisely the same form of probability statement in the reassessment over time.

The importance for the policy-maker-consumer of accepting probabilistic warning estimates cannot be overemphasized because they relate to the type of decision (from drastic down to none) he is attempting to make. He should also remember that if the kind of decision at hand does

not require an estimate of great precision, a higher probability might be expressed. One possibility is for the consumer and the intelligence analyst responsible for a warning estimate to confer and agree on a series of basic probability statements and, without changing the wording, to review from time to time the changes in the probability and the reasons why the changes occurred.

As evidenced by our performance in past crises, our national nervous system is not designed for a coherent response in most situations. Not only do we fail at human communications within our system, but we fail to perceive the interactions between our decision-makers and our opponents. We fail to express our estimates in probabilistic terms and relate these estimates to the kinds of alternative decisions that can be taken.

None of these shortcomings can be overcome by simple panaceas. However, there are steps which can be taken, particularly in the area of more precise communication across the diverse parts of our government. These remedies cannot be administered by any one segment, diplomatic, intelligence, or military. They must be done together.

Reference: Belden, Thomas G., "Indications, Warning, and Crisis Operations," International Studies Quarterly, v. 21, no. 1, March 1977, pp. 181-197.

Interactive Telecommunications via Satellite

by

Earl Henderson

Beginning with the launch of ATS-1, the first in a planned series of seven application and communication technology satellites, the use of interactive communication systems for health and education programs has expanded rapidly. Labeled by such coined words as "teleconference," "telemedicine," and "tele-education," these systems have been used in classrooms, conference halls, libraries, hospitals, and even private homes in small Alaskan villages.

A principal factor leading to the widespread use of this technology was the development of the small earth terminal. Earlier satellite systems employed large ground stations, some with 85-foot diameter antenna systems. In fact, several of the earth stations in the international Intelsat Satellite Network operate with 100-foot antenna systems. These large and costly systems are limited to the most highly sophisticated, multiuser communication networks. It is not surprising, therefore, that the era of small earth terminals, which use antennas only 10 feet in diameter, has had a major impact.

The United States took a major step into the field of communications satellites with the launch of SCORE, the first U. S. active repeater satellite. This satellite, launched in December 1958, transmitted a Christmas message from President Eisenhower. The next milestone came in July 1963 when Syncom, a geosynchronous communications satellite, was launched. Syncom demonstrated the capability which has led to the existing international communications satellite network, Intelsat.

The major breakthrough for small terminals came on December 7, 1967, when NASA launched ATS-1. This satellite provided an audio relay capability for an area greater than one-third of the earth's surface. Positioned over the Pacific Ocean, it has supported programs for the past 10 years, far beyond its projected life span of two years. In 1970 ATS-1 became the heart of a large-scale, interactive, audio telemedicine network. The subsequent ATS-6 and CTS systems have expanded their earth terminal capabilities to include video transmissions. The experimental communication satellites are shown in Table 1.

The Lister Hill National Center for Biomedical Communications, part of the National Library of Medicine, was among the first to join with the National Aeronautics and Space Administration (NASA) to explore the use of satellites for telecommunications. The center sponsored the development and operation of the Alaskan ATS-1 interactive system. This

Mr. Henderson is Chief of the Communications Engineering Branch, Lister Hill National Center for Biomedical Communication, National Library of Medicine.

network provided voice communications between doctors and health aides in 26 remote Alaskan villages and brought to many of its users their first reliable communication link with the outside world. Although this system attempted only to duplicate the capability of a good telephone system, it reached remote villages that had never had land-line telephone service.

Table 1. Experimental U.S. Communication Satellites

<u>System</u>	<u>Date</u>
SCORE	1958
ECHO	1960
COURIER	1960
TELSTAR	1962
RELAY	1962
SYNCOM	1963
EARLYBIRD	1964
ATS-1	1966
ATS-2 (Failed)	1967
ATS-3	1967
ATS-4 (Failed)	1968
ATS-5 (Partial Failure)	1969
ATS-6	1974
CTS	1976

ATS-1 was also used by the National Institutes of Health (NIH) for pan-Pacific teleconferences. Communications between NIH in Bethesda, Maryland and the Cook Islands in the Pacific were conducted weekly in support of the research programs of the National Institute of Allergy and Infectious Diseases.

A larger, pan-Pacific network of 23 sites located in Washington, DC, Appalachia, Alaska, and the Pacific Islands participated in a seven-month teleconference program for educators. This program was conducted

by the National Education Association. The experiment demonstrated the unique ability of satellites to link together large groups from a wide geographical area in a single event. It also showed that too many participants actually limit interaction. As the number of respondents increase, the interactive teleconference network is limited to a passive role for most participants.

In anticipation of NASA's plan to launch the ATS-6 satellite, the Lister Hill Center procured small terminals that could transmit and receive video. Following the 1974 launch of ATS-6, networks of these small terminals were used in a wide range of health and education programs. Video receivers with audio talk-back capability were used in more than 100 facilities throughout the continental United States and Alaska. Joint programs were developed within the Department of Health, Education, and Welfare (DHEW) and the Veterans Administration. Although many ATS-6 programs were limited to less than one year, before the spacecraft was relocated to support programs in India, the success of this demonstration is reflected in the continued interest of participants in planned follow-on programs. The state of Alaska liked its ATS-1 experience enough to install a statewide operational system using a commercial satellite. ATS-6, now back for U. S. usage, is being used to support educational programs in Appalachia.

The Public Health Service of DHEW and the Veterans Administration are conducting programs with ground networks using the CTS spacecraft. The general objectives of the PHS health experiments are to evaluate broadband (video, audio, and data) satellite communications:

- o As an aid to decentralized medical education;
- o As a way to minimize travel, and to reduce the limitations of remote geographic location on the continuing education of health professionals; and
- o As a medium for more effective transfer of new knowledge generated by biomedical research.

Currently, the following health agencies and their components are involved in this experimental program.

- o National Institutes of Health
 - o NIH Office of Communications
 - o National Library of Medicine
- o Health Resources Administration
 - o Bureau of Health Manpower

- o Alcohol, Drug Abuse, and Mental Health Administration
- o National Institute of Drug Abuse

These PHS-sponsored experiments, commencing in 1977, include teleconferencing among health professionals, continuing medical education projects, sharing of off-site faculty resources, off-campus admission interviews and minority recruitment, and other health-related applications. These experiments are summarized in Table 2.

The PHS ground stations will be located at:

1. The University of Alaska, Fairbanks
2. The University of Washington, Seattle
3. The University of Montana, Bozeman
4. The University of Colorado, Denver
5. The University of Kentucky, Lexington
6. The National Library of Medicine, Bethesda, Maryland.

The control center for all CTS ground stations in the United States is located at the NASA Lewis Research Center, Cleveland, Ohio. The network control centers for the PHS-CTS operation will be located at Bethesda and Seattle. All six ground stations are technically identical. They are capable of transmitting and receiving one video and four audio channels; in addition, a separate audio control channel is available. The stations are connected to existing audiovisual facilities at each of the universities. They include studio and conference centers. The Lister Hill Center provides station operators for the earth terminals, and the university operates the audiovisual support functions.

Communications satellites are assumed to be of fundamental importance in developing future communication networks for health education and the transfer of biomedical research results to the practicing community. With satellite-aided communications, transmission costs are technically independent of distance; reliability is independent of terrain. A prime requisite in most health applications is for a spacecraft which permits the use of low-power, relatively low-cost ground stations widely distributed. The predominant commercial use of satellite communications today assumes the use of powerful, high-cost ground transmit installations. It is important, therefore, that the health community identify its needs in the utilization of this technology so that it can effectively define a market of sufficient size to influence the design of suitable future satellites.

Table 2. Summary of PHS-CTS Experiments

<u>Project</u>	<u>Implementing Agency</u>	<u>Communication Mode and Transmission Method</u>
Nursing Child Assessment Satellite Training	University of Washington School of Nursing	1. Full-Duplex Video/Audio, CTS 2. Simplex Video/Audio, CTS 3. Videotapes, In-person
Dietitians Workshop	American Dietetic Association	1. Full-Duplex Video/Audio, CTS 2. In-person
Continuing Dental Education	Consortium comprising Health Systems Research Division, University of Florida, and four schools of dentistry at the Universities of Colorado, Kentucky, Maryland, and Washington	1. Full-Duplex Video/Audio, CTS 2. In-person
Western Region Meeting Teleconference	Association of American Medical Colleges	1. Full-Duplex Video/Audio, CTS
AVLINE Material Review	Association of American Medical Colleges	
Drug Abuse Prevention Teleconference	National Institute on Drug Abuse	1. Full-Duplex Video/Audio, CTS
Admissions and Minority Recruitment	Consortium of four universities: Washington, Alaska, Montana, and Idaho (WAMI)	1. Full-Duplex Video/Audio, CTS 2. In-person
Independent Learning and Faculty Sharing	WAMI	1. In-person 2. Full-Duplex Video/Audio, CTS 3. Prepared Material, Mail
Health Consultation	WAMI	1. Full-Duplex Video/Audio, CTS 2. In-person
Legislative Process	WAMI	1. Full-Duplex Video/Audio, CTS
Research Dissemination	National Institutes of Health	1. Full-Duplex Video/Audio, CTS

Telecommunication R&D--Implications and Support for Library Programs

by

Richard W. H. Lee

Within the last 15 years we have witnessed a definite, although quiet, revolution in library operations in the United States. This drastic change was brought about by the introduction of computers into information processing, which gave rise to the new emphasis on technical services of libraries and the new discipline of information science as it is applied to the traditional field of library science. Before this time, mechanization of library operations was largely based on EAM equipment, microfilms, and mechanical devices such as the Termatrix optical coincidence device or the Royal McBee needle-shakers. In the early sixties, computer applications in libraries were localized and used principally in two quite distinct functional areas. One was the automation of the usual repetitive, labor intensive, administrative type of operations such as ordering and receiving of books and subscriptions, claims, circulation control, routing, accounting, maintenance of master holding lists, and so forth. The other area of application was for systematic information searching and retrieval using computerized bibliographic data bases. The latter has also resulted in the initiation of SDI (selective dissemination of information) or user current awareness services in libraries. Consequently, there has been a great improvement in information services and the efficiency of library operations.

However, such applications did not result in substantial changes in the basic structure or character of libraries. Libraries were operating just as before except a little faster. In most cases, computer searches were offered as a service function separate from the regular library operations and were handled by a special group of information or computer specialists.

With the advent of telecommunication and time-sharing systems in the late sixties, dramatic changes began to take place in libraries. There has been a rapid evolution with respect to their service functions, resource allocation, management philosophy, personnel requirements, staffing pattern, organizational structure, and so on. Some comments on these prominent changes will illustrate this point.

1. The combination of computer and telecommunication has been serving as an effective equalizer among rich and poor, big and small libraries in so far as information services are concerned. Previously, only relatively large and rich private organizations and large Government agencies could afford the luxury of computerized information systems. In those days, in order to establish a computerized system,

Dr. Lee is Associate Program Director, Division of Scientific Information of the National Science Foundation.

one first had to have possession of, or access to, a scarce and expensive resource--a computer (usually in-house), and then had to create and maintain a data base (or bases) and software either through purchase or in-house development. All of these were very expensive and beyond the reach of the average organization and library. But with the rapid development of on-line time-sharing access through commercially available information systems such as Lockheed, SDC, and others, and with the greatly reduced computer and communication costs (e.g., no minimum charge, only connect time is to be paid), almost everyone can afford computerized search. Today, a small library can have access to the same range of computerized files as the largest libraries or information centers. A one-person operation in a small town in a remote place can use a terminal through regular telephone lines to explore the same CAS, ERIC, NTIS, SPIN, or MEDLINE data bases plus a number of specialized files. Thus, the user can have the same literature searching capabilities, sophistication, and comprehensiveness that is offered at a much larger, centrally-located, and rich library.

2. The widely available computerized data bases and on-line processing capability have so vastly improved the accessibility of information resources that they have practically eliminated geographic distance as a barrier to information transfer. Libraries have discovered that they no longer live in isolation. As a matter of fact, they have discovered that it is more desirable to become a node of a network or to form a consortium of some kind to pool their resources. Greater emphasis is now given to resource-sharing activities. Local development is more or less limited to the handling of certain administrative functions such as ordering, cataloging, claims, payment notices, and so forth, which are processed through network programs. In a survey conducted in 1975, it was estimated that over 800 libraries, including most of the major academic and public libraries in the nation, were participating in one or more networks or consortia for sharing resources, using some types of computing and telecommunication equipment to achieve common goals such as cooperative cataloging activities and interlibrary loans. It is reasonable to assume that the total number exceeds 1000 by now.

3. Expanded information service through computer and telecommunications has gradually changed the character of a library. As Mr. Darby said this morning, technology forces change. Slowly but surely libraries are moving away from the traditional, passive, archival storage and book-and-journal services (with limited reference service) and moving into a new era of active information seeking, digesting, and synthesizing organizations. Compiling in-depth and annotated bibliographies, which previously would take weeks to perform, is no longer a specialized and time-consuming chore. The user/librarian interface is taking on a new dimension. Librarians today are actually guiding technical patrons through the process of examining and reexamining their requests for information, defining their problems, refining their search criteria and strategies in order to improve the relevancy and precision of the search results. In addition, librarians are now required to possess a knowledge of the contents, structure, organization, and

idiosyncracies of the various technical data bases. This demands a general knowledge of many subject fields. Furthermore, the librarian is required to be proficient in the technical handling of computer searches through the terminals. He/she must know the protocols of each system and be familiar with the handling of communications through a terminal. Because of the availability of terminals in libraries, patrons are coming in to libraries not only to access computerized data bases but also to receive training through many CAI-type materials and to work with technical types of computer packages, such as mathematics and statistical routines. Thus, libraries are becoming "learning and training centers" where users interact with computer systems. This is an expanded service and function which was not possible before.

These changes have also brought about some new problems such as the requirement for special technical skills, changes in organizational structure, and changes in staffing patterns. Another important problem, about which everyone is concerned, is document delivery. Because of the sophistication of computer systems which render faster and more comprehensive bibliographic searches, there is an increasing demand for the delivery of documents. As Professor Meyer mentioned this morning, we are using twentieth century searching strategy but are still delivering the papers by horse and buggy. It is understandable that a user gets very irritated when given a long list of citations of relevant references but cannot obtain their texts within a short time frame, if at all. It is with this problem that telecommunication technology can really help. Therefore, this is what I am going to talk briefly about--the more recent developments in telecommunications that could help libraries to solve this problem in the future.

Slow Scan Television. The previous speaker has discussed slow scan television (SSTV) techniques in great detail so I shall not dwell on it. To put it briefly, SSTV transmits a video image through a narrow-band channel, i.e., voice-grade telephone line. The trade-off is bandwidth versus time. With SSTV, instead of receiving moving pictures every one-thirtieth of a second, the user receives a still picture ranging from 30 seconds to one minute depending on the resolution desired. With SSTV the user can send and receive images of graphs, engineering drawings, writing on a blackboard, large charts, pictures, and text materials. This gives the user flexibility that the facsimile device does not have because the operation of FAX is dependent on the size of the original sheet to be transmitted.

The advantages of using SSTV in library operations are many. First of all, it adds browsability to interlibrary operations. We can now browse documents through conventional telephone lines to determine, either through the table of contents, or specific portions of the document, whether the document is relevant. We can also pinpoint the needed portion of the document, thus reducing significantly the reproduction and mailing cost. Second, with SSTV we can review and transmit documents at a remote site. Although most of the SSTV manufacturers do not have hard copy capability as such, that does not mean their equipment cannot be modified by attaching some other equipment to it to

obtain hard copies. Of course, there is no reason why a facsimile machine cannot be used in conjunction with SSTV for hard copy transmission. This should be cost-effective, since it is possible to predetermine the exact portion of the document needed, which will minimize the number of pages to be transmitted. Another good use of SSTV is for conferencing. Since SSTV provides two-way visual communication, it can be used very effectively between libraries, or headquarters and regional offices, or among working, technical, and administrative people. With this device, a new service dimension is added to two-way executive conferences, technical work sessions, and briefing and presentation. In addition to the travel expenses saved, the instantaneous quality of the meetings should prove an invaluable asset.

As with other new technology, SSTV has problems. The most critical is the resolution of SSTV using the regular TV display tube. Although there is not much of a problem with the viewing of an ordinary picture, it is grossly inadequate for full text delivery. Several studies done in the past have shown that it requires a minimum of 1200 to an optimum of 2000 scan lines to display a full page of text (with six point type) legibly. Since an ordinary TV tube has only 525 lines, only about one-fourth of a printed page can be displayed on SSTV for good readability. Another problem concerns hard copy production. As mentioned before, there is no equipment at the present that offers hard copy production as part of an integrated system. Auxiliary attachments can be used, but they usually need modification and are expensive. The transmission speed currently stands at about 30 seconds to one minute per picture, which is still on the slow side. With a better compression scheme, transmission speed should be reduced significantly. Although most of the current commercial SSTV equipment handles only one picture at a time, i.e., only one picture can be stored, it is not unreasonable to add more memory to have the capability of storing more than one picture. It is also feasible to record the incoming image signals on some recording medium such as tape or disc and have the pictures played back at a later time.

The potential for applying this technology to library use is great. We do need careful study in this area and must evaluate how this can be applied, to what types of material or information it is suited, and what the required capabilities of hardware and software are. We must also determine the costs and benefits of using this technology.

The project Dr. Meyer mentioned earlier is one which is conducted under the sponsorship of the National Science Foundation. The purpose of the research is to determine how audio communications augmented with SSTV visual images (charts, tables, blueprints, pictures, and so forth) can enhance the effectiveness of person-to-person communications among scientists and engineers. The experiment is being conducted at the several Los Alamos laboratories. Dr. Joan Meier, NOAA, is currently moving rapidly forward to organize a Federal library network, using SSTV and facsimile devices as the major tools. We are watching this effort with great expectation.

Telefacsimile. Facsimile transmission is a form of technology with which we all have some familiarity. Currently, there are about 125,000 units in use in the United States. It was estimated that by the end of 1977 there would be about 200,000, and that figure should be doubled by 1980. Transmission of facsimile images is on the same principle as SSTV. Information bits of an image are squeezed through a narrow-band channel such as the telephone network. Transmission time takes from three to six minutes. With the application of compression and compaction schemes designed to eliminate repetition and remove irrelevancies, transmission time has been reduced to about 30 seconds or less. Rapifax Telefacsimile can transmit black and white images with no shades of gray in 35 seconds. The 3M Company has introduced a high speed facsimile transceiver which is capable of transmitting an average 300 word business letter in about 20 seconds. The 3M machine operates in a full duplex mode at 9600 baud and can send and receive material at the same time. This machine can also double as a standard electrofax office copier and duplicates originals at a rate of six per minute, subject to priority interrupt to receive incoming transmissions. Another commercial firm has announced the development of a machine which can transmit a full page in 15 seconds; however, it is not yet commercially available. The facsimile machine, of course, is in wide use. As indicated before, its principal drawback is that it is size dependent. However, facsimile devices usually are not viewed as systems by themselves. When used in combination with other communication devices such as telephone or SSTV, they can serve a wide range of information needs.

Micro-Image Transmission. Although many years ago microform was thought to be the solution to many library problems, as computers gained in usage, the momentum for microform slowed considerably. Yet, there is a steady, perceptible, slow increase of microform users. In the latest 1977 survey of thousands of commercial firms, 33 percent of them now use microforms, compared with 28 percent a year ago. Because of improvements in computerized bibliographic searching, there is an increased demand for full text delivery; time and cost involved in obtaining and mailing of documents makes remote transmission of micro-image an appealing medium. It seems especially suitable for interlibrary loans as well as document repositories such as NTIS, DDC, ERIC, and others. By having this capability, they could transmit micro-images over telecommunication links instead of packaging and mailing the hard copies. Unfortunately, results of an informal survey indicate that, except in a limited number of cases, most companies who perform research and development in micro-image transmission stopped their efforts about five to seven years ago. This was probably because, at that time, microforms were considered primarily archival media. Thus, the need for transmission was considered minimal. Recently, there has been a gradual change in attitude. It is now realized that microforms need not be limited to archival storage, but actually can be an integral part of a document delivery system involving local reproduction and publishing.

Currently, there are several operational microform image transmission systems, but, to my knowledge, they are all cable connected for

local transmission. The Air Force has one, using closed-circuit television and a 1225-line CRT display. It is equipped with a zoom lens, and can read eight point type. Most of you know that The New York Times also has such a system. There is also one commercial firm which can transmit micro-images at a speed of 15 seconds per frame with 192 x 249 resolution. Long distance micro-image transmission systems exist only as prototypes. A Naval Bureau of Personnel study has shown that the optimum scanning resolution for its personnel records in six point type is 160 lines per inch on full-size documents, or 151 lines per millimeter on 24X reduced-sized microforms. The recommended Navy system consists of a laser-beam, spinning-mirror scanner that scans individual, standard 98-frame microfiche at a rate of 2.4 seconds per image including loading, positioning, scanning, and ejecting the fiche. The recommended output recorder is a laser-beam, spinning-mirror recorder, and the output film is dry-processed, silver-halide film. The recommended transmission link is a wide-band satellite link with an earth station located near each remote site. While the system was a feasible one, development and the initial costs were estimated to be in the millions of dollars. Thus, that approach was abandoned, at least tentatively.

It stands to reason that the costs for developing a system for a single unique application are prohibitive. We are looking to management and R&D people in industry to push for research and product development for generalized applications. We know the Bell Telephone Company has under development a system that can transmit a one page micro-image in five to 10 seconds over broad-band links or in about one minute over telephone lines. The Bell system uses a laser recording on a metallic coated film; the micro-image is rather permanent, compared to conventional microfilms. The Planning Research Corporation has developed its Telefiche system, which allows three-second scanning of a single page of information from a fiche, converts this to digital data, performs image enhancement, and transmits to various forms of output such as paper hard copy, video soft copy, back to fiche, or to computer-readable digital data. It scans each page at a resolution rate of eight lines per millimeter, and produces a raster scan pattern of 1728 x 2200 raster points or 3.8×10^6 pixels per page. Transmission of one page over telephone lines takes either 30 or 60 seconds, depending on the resolution. We are hopeful that with this renewed interest, better and more efficient devices soon will be on the market for library use.

Holography. Holography is known for its high information storage capacity--about 250,000 bits per square centimeter. Compared to conventional magnetic storage devices such as tapes and discs, a significant reduction in storage can be achieved through holographic techniques.

The Rome Air Development Center (USAF) has experimented with a holographic microfiche system since 1973 and has found the results to be highly impressive and satisfactory. Up to 30 million bits can be recorded on one microfiche. Data recording and readout are operated at 500,000 bpi which is comparable to high speed tape systems. Update of information recorded on microfiche can be rapidly done by producing a new first-generation microfiche at a cost of about 35 cents. A mass

storage unit which can stack nine carousel units, each capable of holding 750 microfiche, provides a total storage capacity for 6750 microfiche or a maximum of 2×10^{11} bits of information. The device can access and extract any microfiche within a maximum of 15 seconds.

A California company recently announced the availability of a holographic microfiche which converts electronic source data from computer memory, tape, disc, and so forth, into an optical data page, or hologram. A 4 by 6 inch fiche contains 20,000 individual holograms; each hologram contains up to 10,000 bits of data, giving a total capacity of 200 million bits per fiche. The writing speed of the recorder is stated to be 30 holograms per second on the average. The manufacturer's estimate of cost to produce a master fiche is 50 cents and only five cents per fiche to replicate. During recording, the electronic binary data are converted directly to optical binary data, and formatted by an optical data, page-by-page composer. During retrieval a terminal keyboard directs a laser beam to intercept the appropriate hologram. The optical sensing array captures the entire contents of the hologram, converting the optical data to electronic binary form at an output rate up to five megabits per second. The potential of this technology is tremendous where extremely large data storage is required. Imagine, the contents of the Los Angeles telephone directory can be stored in a single 4 by 6 inch fiche. In addition to the fiche, the manufacturer is also developing roll films to record and retrieve the holograms.

Videodisc. A videodisc looks much like a phonograph record. It is played on a turntable that can be hooked up to a home television set (color or black-and-white) through the two antenna terminals. Basically there are two types of videodiscs. The Discovision system, developed by MCA-Phillips, uses a 12 inch disc that rotates at 1800 rpm (compared with 33-1/3 rpm for a long-playing phonograph record). It uses a small laser beam to pick up the recorded optical patterns on the disc and displays the picture on a TV screen. Each disc has 54,000 tracks. Each track is less than two microns wide and records one full frame of visual material in one revolution of the disc. The disc is protected by a permanent plastic coating, and its performance is not affected by scratches or surface conditions. The 54,000 pictures can be shown as a motion picture for 30 minutes or can be displayed as single still pictures; in the latter case, the laser beam simply keeps traveling over the same track. This technique also provides random access capability. With a hand-held device the size of a small calculator, the user can key in the exact frame to be accessed. The system is primarily designed for home entertainment, and each recorded disc of old movies or Broadway shows is suggested to retail for about 10 dollars. The player costs about 500 dollars. It is rather obvious that there is tremendous potential to use this device for training, for education, and for information storage and retrieval. With a 54,000-page storage, you can put the entire Encyclopaedia Britannica on one disc with room to spare. The format on the disc can be text, graphics, still frames, audio, or full sound motion picture action. The display can be either black and white or color, and content can be retrieved on demand by random access.

The rival system developed by RCA, instead of being optical, is electromechanical. It uses a stylus traveling in a groove. It lacks the random access, single-frame, and slow-motion capability of the MCA. Therefore, it is not quite suitable for library information handling.

One problem with videodisc for text delivery is basically the same as with SSTV, i.e., image resolution. Since a regular TV screen has only 525 scan lines, only about one quarter of a printed page can be displayed legibly. On the other hand, for small-size documents such as catalog cards or training and education materials, it still represents an excellent choice. Another problem with videodisc is remote transmission. At this moment it is used only for local storage and display. Transmission of images over long distance could be done through telephone lines, but at the rate of 30 seconds per frame some of the best advantages of videodisc are lost.

There are three other areas which I originally intended to cover, but due to the press of time I shall skip. They are two-way cable television, glass fiber light guide (optic fibers), and satellite transmission. Earl Henderson has already covered the use of satellites for interactive communications and teleconferencing.

I would like to mention two additional points. First, a word of caution. We must view all of the new technology as tools for our optimal use. A tool is utilized only when it is cost-effective in its application, not because it is novel or interesting. I would strongly urge anyone who wishes to use any new technology, satellite included, to conduct a thorough cost/benefit evaluation before plunging into it. Such cost/benefit data are grossly lacking at the moment and need to be developed. The other point I would like to mention is the time delay in satellite transmission. It takes approximately 0.15 second to reach the satellite and another 0.15 second to reach the receiving end. So there is a 0.3 second time delay. In an interactive mode, incoming response also takes 0.3 second to arrive; therefore, there is a total delay of 0.6 second. By contrast, maximum domestic terrestrial transmission delay is 0.02 second. Of course, the cost of transmission via satellite has the advantage of being independent of terrestrial distance.

In closing, I would like to say that the National Science Foundation has sponsored several studies on the forecasting of information processing requirements and information technology. Conclusions reached from these studies indicate that we have enough technology in existence today to meet all the foreseeable needs for the generation, distribution, and storage of scientific and technical information until 1985. The problem is not that we lack available technology, but rather that we are not applying it to its fullest potential. Therefore, one of the objectives of the National Science Foundation's Division of Science Information is to stimulate and encourage innovative application of technology for information processing, storage, and transfer. We would be happy to talk with each one of you who has an interest in this area, and perhaps we can put forth a joint effort in undertaking these projects.

Videodiscs--A Fast Retrieval, Mass Storage Medium for Libraries

by

Robert B. J. Warnar, Madeline M. Henderson, and Patricia W. Berger

More than one hundred years have elapsed since Thomas A. Edison invented the phonograph recorder/playback system in 1877. The original record was cylindrical in shape. Emile Berliner improved Edison's invention 11 years later by changing the form to a flat disc; he called it a Gramophone. The disc was attractive despite the problem posed by the continual linear change of groove speed due to the decreasing lengths of consecutive spiral tracks. It offered a significant increase in playing time and low production cost.

The Gramophone record constituted the second major breakthrough in information storage and retrieval technology after the appearance of the printing press. Vast quantities of information, first made reproducible and portable by printing, could now be accessed audibly on records. The next major breakthrough followed rapidly; in 1891, Thomas Edison invented motion pictures and expanded the collection and retrieval tools of information technology to encompass written material, sound, and moving images in a single information system.

In time, other methods using magnetic and electronic memory techniques were devised to store massive volumes of data. A new data handling machine called the electronic computer was introduced. Magnetic tape and drum memories were used to supply the memory hierarchies of the early computer systems. The drum was used for main memory and magnetic tape served as mass or peripheral storage. An array of sensors was placed near the drum surface in order to cover as much information as possible in the drum.

As happened in the evolution of the phonograph record, the cylindrical drums have been replaced by magnetic disc memory. The reasons appear to be the same as before: disc storage systems generally have greater storage capacity and lower costs than drum (cylindrical) systems. However, there are striking differences between audio discs and magnetic discs. Audio records are primarily in analog form; most magnetic disc systems record in digital form. In addition, the design of magnetic disc systems allows the pickup arms (or heads) to be placed at any track on the platter within tens of milliseconds; thus, data can be retrieved very quickly.

Mr. Warnar is on the staff of the Institute for Computer Sciences and Technology, National Bureau of Standards. At the time of this Conference, Ms. Henderson was Chief of the Computer Information Service, Institute for Computer Sciences and Technology, National Bureau of Standards. Ms. Berger is Chief of the Library and Information Services Division, National Bureau of Standards.

Currently, magnetic disc systems composed of multiple stacked discs store as much as 10 billion bits of data. This has made possible the storage of hundreds of on-line data bases, which are currently used by librarians for bibliographic searching and retrieval of the published literature.

Now a newer disc technology, called videodiscs or optical discs, is emerging. Videodisc systems transmit all the information necessary for the perception of written material, sound, and moving images. This capability promises the evolution of better information recording/retrieving systems than are available currently.

Videodisc Technology

Most videodiscs look like phonograph records. They are 12 inches (30 centimeters) in diameter, are played on turntables, and produce electronic signals much like long-playing (LP) audio records. Some videodisc playback systems even use needle-in-the-groove pickups for retrieving the recorded information. However, videodiscs contain orders-of-magnitude more information than common audio records. Even though both types of records are played on turntables for about one-half hour a side, the videodisc system produces enough information to simultaneously operate several audio channels plus a video channel. Whereas a good LP record covers the normal audio spectrum to over 15,000 vibrations per second (15 kilohertz), an advanced videodisc system covers almost one thousand times the LP's bandwidth. As a result, storage capacity of one video disc is almost 10 billion bits of information.

About 100,000 television picture frames can be stored on one optical videodisc. A master optical videodisc has holes that are generated by a high-power, narrow-beam laser, located on the spiral tracks of the disc. These holes are similar to the indentations in audio-record grooves and contain the recorded information on the disc. There are 54,000 spiral tracks per disc side, compared to about 1000 grooves on an LP. The master reproduction disc is used as a mold in a high-pressure injection molding machine. The mass production process for videodiscs is quite similar to that used to generate multiple LP's from a single master.

Not all videodiscs are vinyl records; a round piece of exposed film works just as well. This type of optical videodisc is manufactured from a photographic film that has been exposed to a high intensity light source, such as a laser beam. The resulting "dots" on the spiral tracks of the disc record information similar to that recorded on a solid disc. Film media discs offer special advantages in situations where rapid reproduction of discs is desirable. In addition, optical videodiscs play up to one hour. The disc rotates at 1800 rpm on a turntable and the 54,000 full-color pictures recorded on each side can be individually addressed by remote control. In other words, this feature allows single frame display capability, so that about 100,000 different frames are available on a single videodisc.

Several manufacturers are currently experimenting with multiple videodisc packs for application as computer mass memories. One such system employs an optical disc pack of six double sided discs with information recorded on both sides; both sides of all six records are individually addressed by a laser-stylus read head. This videodisc "jukebox" arrangement supports a storage capacity of 1 trillion bits, and is the largest portable memory yet devised. However, further improvements, such as even faster data access rates, are still possible in the future.

Videodisc data transmission is compatible with commercial television. This, paired with long life and low cost (some manufacturers claim 100 years of storage for less than 10 dollars per disc) plus fast data retrieval, should make videodiscs highly attractive storage media for libraries and archives. Because their recorded data is found inside the record rather than on its surface, optical videodiscs are characterized by slow data decay rates. The laser pickup is focused in the data in the record, and the contact between pickup and disc is optical, rather than mechanical. Dirt, scratches, fingerprints, and so forth, cannot mar or erase the data. Consequently, the manner in which optical discs are stored, operated, or handled has little or no effect on the quality of the data recorded in them.

Impact on Library Operations

Videodiscs present attractive storage and retrieval capabilities for libraries, because they offer a way to combine mixes of digital, audio, and visual data into a single format. Thus, training and instructional materials, special educational materials and archival storage of various data elements can be developed and stored by the library for future use. Unlike microforms, videodiscs constitute a relatively stable, easily accessed storage media--one which is unaltered by rough handling or radical shifts in temperatures and humidity. These characteristics, plus their increased data storage capacity, make videodiscs superior media for maintaining back files of journals, archives of technical reports, copies of laboratory notebooks, engineering drawings, and so forth.

In addition, discs offer an opportunity for creating or maintaining lectures and similar workshop and training session materials for library and information science personnel. Tomorrow's library or information center may well find itself a contributor to, as well as a participant in, a regional continuing education program which uses videodiscs to update, retrain, and broaden the skills and knowledge of professional, paraprofessional, and clerical library personnel in area libraries.

Because of its fast random access and electronic addressing capabilities, the videodisc provides a degree of information dissemination not readily available or achievable through the circulation of books, journals and technical reports. As Becker and Hayes have observed, "while circulation suggests a reader taking a book out of a library, dissemination includes both this and active transmission of the contents

to a reader. Cataloging suggests the standard author, title and subject guides. Indexing includes not only these, but greater depth of detail as well through the ability...to process vast amounts of data according to detailed and complex instructions."¹

The implications for state-of-the-art and SDI library services are formidable--discs of newly received journal issues, discs of selected new monographs and technical reports might be purchased (or generated) monthly and duplicated as needed to furnish "active transmission" of information packages to the library's users. Library staff hours formerly used to log in, locate, store, and maintain paper copies of books, reports, and periodical issues can be used to identify, assemble, and disseminate selected information elements to library users.

Unlike microform technology, videodiscs and videotape depend on a technology already accepted and in use, namely, television. Both media have a market far in excess of the library market; therefore, the TV attachments they require will be in demand, will be mass produced, and will be relatively cheap. These features add up to increased information storage and retrieval capabilities for the library of the future, plus possible decreases in acquisitions and processing costs.

Impact on Library Users

The use of videodisc technology in the library will enhance some services already offered to library users, and introduce new services not feasible now. For example, visual display of "converted" textual material will be improved. Whereas the user now relies upon microform storage and blowback of images, the videodisc system will store more material in less space with better quality reproduction. Videodisc storage and selection equipment, combined with high quality copying capability, will permit the user to browse through a file of information, select items of interest, produce copies, and compile a tailor-made file for subsequent use. Today's microform file does not have the capability and quality of image that a comparable videodisc storage file will have.

In addition, the availability of combined audio and visual displays will enable the library to offer recorded lectures and demonstrations to users. Such displays will be readily available because a TV screen will be used for blowback--a movie projector is not required. Display screens equipped with headphone attachments will not require a special isolated projection area because they will be no more disturbing to other library patrons than today's LP record-playing facilities.

The scope of such improved new services is not hard to imagine. In a scientific and technical library, for example, lectures by distinguished colleagues in distant universities would be available in timely fashion, for frequent use, by one or several users at a time, with

¹Robert M. Hayes and Joseph Becker, Handbook of Data Processing for Libraries (New York: Wiley-Becker-Hayes, 1971), p. 697.

quality of production that would rival the live performance. The lecturer could insert textual materials, conduct demonstrations, and repeat portions of the discussions as appropriate. The users could also repeat portions as desired. Unlike closed-circuit TV use, videodisc stored materials are available at the user's convenience, and with better reproduction quality to enhance the impact of the message.

The overall or long-range impact on the user must include the results of compact storage of materials and their compact display. The potential cost and space savings of videodiscs and their storage can be used to acquire additional materials or to offer additional services to the library/information service user. This is of particular importance when one considers the increasing volume of computerized interactive bibliographic searches in scientific and technical fields; King notes a nearly 160 percent growth between 1971 and 1974 "and even more rapid growth is anticipated in the future."² Use of broad-based computerized files generates additional requirements for document access; the library/information center must provide access to an increasing number of journals and books relevant to the user's interest. Acquisition and storage of materials in videodisc form will make such increased access possible.

The Direction of Videodisc Developments

As we have discussed, optical videodiscs furnish new information capabilities for many data handling users. They furnish nonerasable, high-capacity, low-cost data storage for information and data retrieval purposes or for creating teaching and training aids. For example, one videodisc can contain pictures of all the parts necessary to build a modern XM-1 tank. Five videodiscs are sufficient to illustrate all the parts necessary to assemble an entire F-14 fighter aircraft and in addition, over ten seconds of audio information can be made available to explain each picture. Disc storage saves paper, space, and look-up time, provides ease of handling, and facilitates training. The system can include feature segment magnification; that is the magnification of predetermined areas of the display can be presented in several steps of the training session. In addition, "magnified information" can be stored in consecutive tracks of the disc and these tracks can be addressed by remote control. This feature would require significant redundancy of stored data; however, the added training and instructional capability would furnish the user a powerful tool.

Videodiscs store more data and cost less than magnetic discs. Unlike the magnetic disc, at present the videodisc is not erasable. Therefore, it probably will not replace the magnetic disc, but it can displace magnetic tape and disc technologies in the rapidly expanding mass memory market, where its major application may be the read-only

²D. W. King, et al., Statistical Indicators of Scientific and Technical Communication, 1960-1980, Volume 1, A Summary Report for the National Science Foundation (Washington, D.C., U.S. Government Printing Office, 1976) p. 60.

mass memory. Videodisc computer mass memories are not yet available, but it is projected that a quadrillion bit memory consisting of 1000 optical discs will be available in the near future. For some applications, this disc capacity could replace 6 million reels of tape. Further developments and improvements in systems capacity, access speeds, equipment volume, data rates, and low-power, energy-saving operation are highly likely.

While many librarians are very interested in the applications of optical videodisc technology to library operations, at present videodiscs are not applicable because they employ regular television screens which have a capacity of 525 scan lines. The image resolution from such a screen is poor because it limits display of text material to a quarter of a page at a time. What is needed is a system with over 2000 scan lines in order to display a full page per TV frame. However, since most current systems are aimed at the home entertainment market, chances are that videodisc system design will concentrate on the systems using the 525 line screens. Therefore, it behooves librarians and their computer specialist colleagues to become involved in the processes of videodisc development and to push for systems useful and adequate for library adaptation in order to assure a wide spectrum of future developments and applications of videodisc technology.

U.S. DEPT. OF COMM. BIBLIOGRAPHIC DATA SHEET <i>(See instructions)</i>	1. PUBLICATION OR REPORT NO. NBS SP 610	2. Performing Organ. Report No.	3. Publication Date December 1981
4. TITLE AND SUBTITLE Telecommunication Technologies, Networking and Libraries Proceedings of a Conference, Held at the National Bureau of Standards, Gaithersburg, MD, June 3, 1977			
5. AUTHOR(S) Nancy H. Knight			
6. PERFORMING ORGANIZATION <i>(If joint or other than NBS, see instructions)</i> NATIONAL BUREAU OF STANDARDS N.H. Knight DEPARTMENT OF COMMERCE 10608 Fiesta Road WASHINGTON, D.C. 20234 Fairfax, VA 22032		7. Contract/Grant No.	8. Type of Report & Period Covered Final
9. SPONSORING ORGANIZATION NAME AND COMPLETE ADDRESS <i>(Street, City, State, ZIP)</i> National Bureau of Standards Washington, DC 20234			
10. SUPPLEMENTARY NOTES Library of Congress Catalog Card Number: 81-600069 <input type="checkbox"/> Document describes a computer program; SF-185, FIPS Software Summary, is attached.			
11. ABSTRACT <i>(A 200-word or less factual summary of most significant information. If document includes a significant bibliography or literature survey, mention it here)</i> The conference provided an overview of current and developing technologies for digital transmission of image data that are likely to have an impact on the operations of libraries and information centers or provide support for information networking. Technologies reviewed include slow-scan television, teleconferencing, and videodisc. Other papers discuss technology and standards development for computer network interconnection through hardware and software, particularly packet-switched networks; computer network protocols for library and information service applications; the structure of a national bibliographic telecommunications network; and the major policy issues involved in the regulation or deregulation of the common communications carriers industry.			
12. KEY WORDS <i>(Six to twelve entries; alphabetical order; capitalize only proper names; and separate key words by semicolons)</i> computer network interconnection; computer network protocol; digital transmission of information; electronic message transmission; image transmission; information networks; national bibliographic network; satellite communications; slow-scan			
13. AVAILABILITY television; telecommunications policy; teleconferencing; videodiscs <input checked="" type="checkbox"/> Unlimited <input type="checkbox"/> For Official Distribution. Do Not Release to NTIS <input checked="" type="checkbox"/> Order From Superintendent of Documents, U.S. Government Printing Office, Washington, D.C. 20402. <input type="checkbox"/> Order From National Technical Information Service (NTIS), Springfield, VA. 22161		14. NO. OF PRINTED PAGES 90	15. Price \$4.75

NBS TECHNICAL PUBLICATIONS

PERIODICALS

JOURNAL OF RESEARCH—The Journal of Research of the National Bureau of Standards reports NBS research and development in those disciplines of the physical and engineering sciences in which the Bureau is active. These include physics, chemistry, engineering, mathematics, and computer sciences. Papers cover a broad range of subjects, with major emphasis on measurement methodology and the basic technology underlying standardization. Also included from time to time are survey articles on topics closely related to the Bureau's technical and scientific programs. As a special service to subscribers each issue contains complete citations to all recent Bureau publications in both NBS and non-NBS media. Issued six times a year. Annual subscription: domestic \$13; foreign \$16.25. Single copy. \$3 domestic; \$3.75 foreign.

NOTE: The Journal was formerly published in two sections: Section A "Physics and Chemistry" and Section B "Mathematical Sciences."

DIMENSIONS/NBS—This monthly magazine is published to inform scientists, engineers, business and industry leaders, teachers, students, and consumers of the latest advances in science and technology, with primary emphasis on work at NBS. The magazine highlights and reviews such issues as energy research, fire protection, building technology, metric conversion, pollution abatement, health and safety, and consumer product performance. In addition, it reports the results of Bureau programs in measurement standards and techniques, properties of matter and materials, engineering standards and services, instrumentation, and automatic data processing. Annual subscription: domestic \$11; foreign \$13.75.

NONPERIODICALS

Monographs—Major contributions to the technical literature on various subjects related to the Bureau's scientific and technical activities.

Handbooks—Recommended codes of engineering and industrial practice (including safety codes) developed in cooperation with interested industries, professional organizations, and regulatory bodies.

Special Publications—Include proceedings of conferences sponsored by NBS, NBS annual reports, and other special publications appropriate to this grouping such as wall charts, pocket cards, and bibliographies.

Applied Mathematics Series—Mathematical tables, manuals, and studies of special interest to physicists, engineers, chemists, biologists, mathematicians, computer programmers, and others engaged in scientific and technical work.

National Standard Reference Data Series—Provides quantitative data on the physical and chemical properties of materials, compiled from the world's literature and critically evaluated. Developed under a worldwide program coordinated by NBS under the authority of the National Standard Data Act (Public Law 90-396).

NOTE: The principal publication outlet for the foregoing data is the Journal of Physical and Chemical Reference Data (JPCRD) published quarterly for NBS by the American Chemical Society (ACS) and the American Institute of Physics (AIP). Subscriptions, reprints, and supplements available from ACS, 1155 Sixteenth St., NW, Washington, DC 20056.

Building Science Series—Disseminates technical information developed at the Bureau on building materials, components, systems, and whole structures. The series presents research results, test methods, and performance criteria related to the structural and environmental functions and the durability and safety characteristics of building elements and systems.

Technical Notes—Studies or reports which are complete in themselves but restrictive in their treatment of a subject. Analogous to monographs but not so comprehensive in scope or definitive in treatment of the subject area. Often serve as a vehicle for final reports of work performed at NBS under the sponsorship of other government agencies.

Voluntary Product Standards—Developed under procedures published by the Department of Commerce in Part 10, Title 15, of the Code of Federal Regulations. The standards establish nationally recognized requirements for products, and provide all concerned interests with a basis for common understanding of the characteristics of the products. NBS administers this program as a supplement to the activities of the private sector standardizing organizations.

Consumer Information Series—Practical information, based on NBS research and experience, covering areas of interest to the consumer. Easily understandable language and illustrations provide useful background knowledge for shopping in today's technological marketplace.

Order the above NBS publications from: Superintendent of Documents, Government Printing Office, Washington, DC 20402.

Order the following NBS publications—FIPS and NBSIR's—from the National Technical Information Services, Springfield, VA 22161.

Federal Information Processing Standards Publications (FIPS PUB)—Publications in this series collectively constitute the Federal Information Processing Standards Register. The Register serves as the official source of information in the Federal Government regarding standards issued by NBS pursuant to the Federal Property and Administrative Services Act of 1949 as amended, Public Law 89-306 (79 Stat. 1127), and as implemented by Executive Order 11717 (38 FR 12315, dated May 11, 1973) and Part 6 of Title 15 CFR (Code of Federal Regulations).

NBS Interagency Reports (NBSIR)—A special series of interim or final reports on work performed by NBS for outside sponsors (both government and non-government). In general, initial distribution is handled by the sponsor; public distribution is by the National Technical Information Services, Springfield, VA 22161, in paper copy or microfiche form.

U.S. DEPARTMENT OF COMMERCE
National Bureau of Standards
Washington, DC 20234

POSTAGE AND FEES PAID
U.S. DEPARTMENT OF COMMERCE
COM-215



OFFICIAL BUSINESS

Penalty for Private Use, \$300

THIRD CLASS
