

# Teleportation improvement by inconclusive photon subtraction

Stefano Olivares,<sup>1</sup> Matteo G. A. Paris,<sup>2</sup> and Rodolfo Bonifacio<sup>1</sup>

<sup>1</sup>*Dipartimento di Fisica and Unità INFN, Università degli Studi di Milano, Italy*

<sup>2</sup>*Quantum Optics & Information Group, INFN Unità di Pavia, Italy*

Inconclusive photon subtraction (IPS) is a conditional measurement scheme to force nonlinear evolution of a given state. In IPS the input state is mixed with the vacuum in a beam splitter and then the reflected beam is revealed by ON/OFF photodetection. When the detector clicks we have the (inconclusive) photon subtracted state. We show that IPS on both channels of an entangled twin-beam of radiation improves the fidelity of coherent state teleportation if the energy of the incoming twin-beam is below a certain threshold, which depends on the beam splitter transmissivity and the quantum efficiency of photodetectors. We show that the energy threshold diverges when the transmissivity and the efficiency approach unit and compare our results with that of previous works on *conclusive* photon subtraction.

PACS numbers: 03.65.Ud,03.67.Mn,03.67.Uk,42.50.Dv

Keywords: teleportation, entanglement

## I. INTRODUCTION

Quantum information processing exploits quantum properties of physical objects, basically entanglement, to improve performances of communication channels and computational schemes. Perhaps, the most impressive quantum information protocol realized so far is teleportation, where the inherent nonlocality of entangled states is manifestly demonstrated. Teleportation experiments have been mostly performed in the optical domain both for polarization qubit [1, 2] and coherent states of a continuous variable (CV) system (a single mode radiation field) [3]. In optical CV teleportation entanglement is provided by the so-called twin-beam (TWB) of radiation

$$|\text{twb}\rangle\rangle_{ab} = \sqrt{1-x^2} \sum_{n=0}^{\infty} x^n |n\rangle_a |n\rangle_b, \quad (1)$$

$a$  and  $b$  being two modes of the field and  $x$  the TWB parameter (without loss of generality we can take  $x$  real,  $0 < x < 1$ ). TWBs are produced by spontaneous down-conversion in nondegenerate optical parametric amplifiers.  $|\text{twb}\rangle\rangle_{ab}$  is a pure state and thus its entanglement can be quantified by the excess Von-Neumann entropy [4, 5, 6, 7]. The entropy of a two-mode state  $\varrho$  is defined as  $S[\varrho] = -\text{Tr}\{\varrho \log \varrho\}$  whereas the entropies of the two modes  $a$  and  $b$  are given by  $S[\varrho_j] = -\text{Tr}_j\{\varrho_j \log \varrho_j\}$ ,  $j = a, b$ ,  $\varrho_a = \text{Tr}_b\{\varrho\}$  and  $\varrho_b = \text{Tr}_a\{\varrho\}$  denoting the partial traces. The degree of entanglement of the state  $\varrho$  is given by  $\Delta = S[\varrho_a] + S[\varrho_b] - S[\varrho]$ , which formalizes the idea that the stronger are the correlations in the two-mode pure state, the more disordered should be the two modes taken separately. Since  $|\text{twb}\rangle\rangle_{ab}$  is a pure state, we have that  $S[\varrho] = 0$  and  $S[\varrho_a] = S[\varrho_b]$  [8], so that  $\Delta = -\log(1-|x|^2) - |x|^2 \log |x|^2 / (1-|x|^2)$  in terms of the TWB parameter and  $\Delta = \log(1+N/2) + N/2 \log(1+2/N)$  in terms of the number of photons of the TWB  $N = 2|x|^2/(1-|x|^2)$ . Notice that for *pure* state  $\Delta$  represents the unique measure of entanglement [9] and that TWBs are maximally entangled states for a given (av-

erage) number of photons. The degree of entanglement is a monotonically increasing function of either  $|x|$  or  $N$ . The larger is the entanglement the higher (closer to unit) is the fidelity of teleportation based on TWB.

The TWB parameter, which is sometimes also referred to as the squeezing parameter of  $|\text{twb}\rangle\rangle_{ab}$ , is given by  $x = \tanh \mathcal{G}$  with  $\mathcal{G} \propto \chi^{(2)}L$ ,  $\chi^{(2)}$  being the nonlinear susceptibility of the crystal used as amplifying medium and  $L$  an effective interaction length. For a given amplifier, the TWB parameter and thus the amount of entanglement, is in principle fixed. However, since nonlinearities are small, and the crystal length cannot be increase at will, it is of interest to devise suitable quantum operations to increase entanglement and in turn to improve teleportation fidelity. In Ref. [10] Opatrný *et al* suggest photon subtraction (PS) as a scheme to increase entanglement, whereas in Ref. [11] Milburn *et al* show that the fidelity of coherent state teleportation with PS is indeed increased for any value of the initial TWB parameter and of the coherent amplitude. PS is based on mixing each channel of a TWB with the vacuum in a high transmissivity beam splitter and then counting the number of photons in one of the outgoing arms (probe mode). Upon detecting exactly one photon in both probes one has the photon-subtracted and thus entanglement enhanced, state to be used in a teleporting device. Although recent developments toward effective photocounting are encouraging, the discrimination of one photon from zero, two, three and so on is still experimentally challenging. Therefore, the PS scheme studied in Refs. [10, 11] appears to be of difficult implementation. Here we focus our attention on the experimental implementation of CV teleportation and, therefore, analyze a different PS scheme where photodetection after the beam splitter is inconclusive *i.e.* it is performed by a realistic ON/OFF (Geiger-like) detector which only discriminates, with quantum efficiency  $\eta$ , the vacuum from the presence of any number of photons. As we will see, inconclusive photon subtraction (IPS) is an effective method to increase photon correlations of TWB and, in turn, to improve fidelity in coherent state

teleportation, provided that the initial TWB energy is below a certain value.

The paper is structured as follows: in Section II we describe in details the IPS scheme, whereas in Section III we analyze the use of the IPS output state in coherent state teleportation. Section IV closes the paper with some concluding remarks.

## II. THE INCONCLUSIVE PHOTON SUBTRACTION SCHEME

In IPS the two channels of TWB impinge onto two beam splitters each with transmissivity  $\tau$ , which we consider equal, where they are mixed with the vacuum state

$|0\rangle_c|0\rangle_d$  of modes  $c$  and  $d$  (see Figure 1). The effect of the beam splitter on two modes, say  $a$  and  $c$ , is described by the unitary operator

$$U_{ac}(\tau) = \exp[\lambda_\tau(ac^\dagger - a^\dagger c)], \quad (2)$$

where

$$\lambda_\tau = \arctan\left(\sqrt{\frac{1-\tau}{\tau}}\right) \quad (3)$$

and  $a$ ,  $c$ ,  $a^\dagger$  and  $c^\dagger$  are the annihilation and creation operators for modes  $a$  and  $c$ , respectively. After the beam splitters the wave function of the system is

$$\begin{aligned} |\psi_{\text{BS}}\rangle &= U_{ac}(\tau)U_{bd}(\tau)|\text{twb}\rangle_{ab}|0\rangle_c|0\rangle_d \\ &= \sqrt{1-x^2} \sum_{n=0}^{\infty} (x\tau)^n \sum_{p,q=0}^n \left(\frac{1-\tau}{\tau}\right)^{\frac{p+q}{2}} \sqrt{\binom{n}{p}\binom{n}{q}} |n-p\rangle_a |n-q\rangle_b |p\rangle_c |q\rangle_d. \end{aligned} \quad (4)$$

Now, we perform a conditional *inconclusive photon subtraction* revealing the mode  $c$  and  $d$  by ON/OFF photodetection. The POVM  $\{\Pi_0(\eta), \Pi_1(\eta)\}$  (positive operator-valued measure) of each ON/OFF detector is given by

$$\Pi_0(\eta) = \sum_{j=0}^{\infty} (1-\eta)^j |j\rangle\langle j|, \quad \Pi_1(\eta) = \mathbb{1} - \Pi_0(\eta), \quad (5)$$

$\eta$  being the quantum efficiency. Overall, the conditional measurement on the modes  $c$  and  $d$ , is described by the POVM

$$\Pi_{00}(\eta) = \Pi_{0,c}(\eta) \otimes \Pi_{0,d}(\eta), \quad (6)$$

$$\Pi_{01}(\eta) = \Pi_{0,c}(\eta) \otimes \Pi_{1,d}(\eta) \quad (7)$$

$$\Pi_{10}(\eta) = \Pi_{1,c}(\eta) \otimes \Pi_{0,d}(\eta), \quad (8)$$

$$\Pi_{11}(\eta) = \Pi_{1,c}(\eta) \otimes \Pi_{1,d}(\eta). \quad (9)$$

We are interested in the situation when both the detectors click. The corresponding conditional state for the modes  $a$  and  $b$  will be referred to as the IPS state. Notice that this kind of measurement is *inconclusive*, *i.e.* it does not discriminate the number of photons present in the beams: one can only say that a certain unknown number of photons has been revealed and, then, subtracted from each mode and that this number, in general, is not the same for the two modes. The probability of observing a click in both the detectors is given by

$$\begin{aligned} p_{11}(x, \tau, \eta) &= \text{Tr}_{abcd} \{ \varrho_{\text{BS}} \mathbb{1}_a \otimes \mathbb{1}_b \otimes \Pi_{11}(\eta) \} \\ &= \frac{x^2 \eta^2 (1-\tau)^2 \{1 + x^2 [1 - \eta(1-\tau)]\}}{\{1 - x^2 [1 - \eta(1-\tau)]\} \{1 - x^2 [1 - \eta(1-\tau)]^2\}}, \end{aligned} \quad (10)$$

where  $\varrho_{\text{BS}} = |\psi_{\text{BS}}\rangle\langle\psi_{\text{BS}}|$  and the corresponding conditional state reads as follows

$$\begin{aligned} \varrho_{\text{IPS}}(x, \tau, \eta) &= \frac{\text{Tr}_{cd} \{ \varrho_{\text{BS}} \mathbb{1}_a \otimes \mathbb{1}_b \otimes \Pi_{11}(\eta) \}}{p_{11}(x, \tau, \eta)} \\ &= \frac{1-x^2}{p_{11}(x, \tau, \eta)} \sum_{n,m=0}^{\infty} (x\tau)^{n+m} \sum_{h,k=0}^{\text{Min}[n,m]} f_{h,k}(\tau, \eta) \sqrt{\binom{n}{h}\binom{n}{k}\binom{m}{h}\binom{m}{k}} \\ &\quad \times |n-k\rangle_a |n-h\rangle_b |m-h\rangle_a |m-k\rangle_b \end{aligned} \quad (11)$$

where

$$f_{h,k}(\tau, \eta) = [1 - (1 - \eta)^h] [1 - (1 - \eta)^k] \left( \frac{1 - \tau}{\tau} \right)^{h+k}. \quad (12)$$

The mixing with the vacuum in a beam splitter with transmissivity  $\tau$  followed by ON/OFF detection with quantum efficiency  $\eta$  is equivalent to mixing with an effective transmissivity

$$\tau_{\text{eff}}(\tau, \eta) = 1 - \eta(1 - \tau) \quad (13)$$

followed by an ideal (*i.e.* efficiency equal to one) ON/OFF detection. Therefore, the IPS state (11) can be studied for  $\eta = 1$  and replacing  $\tau$  with  $\tau_{\text{eff}}$ . In this way, the conditional probability (10) of obtaining the IPS state rewrites as

$$p_{11}(x, \tau_{\text{eff}}) = \frac{x^2(1 - \tau_{\text{eff}})^2(1 + x^2\tau_{\text{eff}})}{(1 - x^2\tau_{\text{eff}})(1 - x^2\tau_{\text{eff}}^2)}, \quad (14)$$

which, in general, is larger than the corresponding probability for *conclusive* photo-subtraction methods, where

$$\Delta_{a,b}(x, \tau_{\text{eff}}) = \frac{\langle d^2 \rangle - \langle d \rangle^2}{\langle n_a + n_b \rangle} = \frac{(1 - \tau_{\text{eff}})(1 - x^2\tau_{\text{eff}}^2)^2(2 - x^2 - x^4\tau_{\text{eff}})}{(1 + \tau_{\text{eff}})(1 - x^2\tau_{\text{eff}})[2 - x^2(1 + \tau_{\text{eff}} + \tau_{\text{eff}}^2) + x^6\tau_{\text{eff}}^3]} \quad (15)$$

where  $d = n_a - n_b$  with  $n_a = a^\dagger a$  and  $n_b = b^\dagger b$ .  $\Delta_{a,b}(x, \tau_{\text{eff}})$  in Eq. (15) is a measure of the *difference number squeezing* *i.e.* of the photon correlation between the two modes rather than entanglement. Notice that for TWB  $\Delta_{a,b}(x) = 0$ , *i.e.* this state shows perfect correlation in the photon number. For  $\tau_{\text{eff}}$  approaching unit, Eq. (15) can be approximated by  $\Delta_{a,b}(x, \tau_{\text{eff}} \rightarrow 1) \approx \frac{1}{2}(1 - \tau_{\text{eff}})$  *i.e.*  $\Delta_{a,b}(x, \tau_{\text{eff}})$  becomes independent from the TWB parameter  $x$ . As we will see in the next Section, although the photon correlation in the IPS state is apparently decreased, the fidelity of IPS-based teleportation is increased with respect to TWB.

### III. INCONCLUSIVE PHOTON SUBTRACTION AND TELEPORTATION

In order to implement quantum teleportation, the IPS state (11) is shared between Alice and Bob (Figure 1). Alice mixes the mode  $a$  of the IPS state with a given quantum state, which she wishes to teleport to Bob, on a 50/50 beam-splitter and then she measures the two conjugated quadratures  $x_- = \frac{1}{2}(e + e^\dagger)$  and  $p_+ = \frac{i}{2}(f^\dagger - f)$  (corresponding to position difference and momentum sum respectively),  $e$  and  $f$  being the two modes outgoing

the same (known) number of photons is subtracted from the input states [10, 11] (Figure 2). In fact, in IPS case the coincidence between the two detectors can occur also when a different (unknown) number of photons is revealed.

In Figure 3 we plot the average photon number of TWB and of the IPS state: below a certain threshold value for  $x$  the energy of the IPS state is increased. As a matter of fact, the IPS state is no longer a pure state and, therefore, the excess Von-Neumann entropy cannot be used to quantify the degree of entanglement. In order to characterize the IPS state we analyze the quantity

the beam splitter. These results are classically sent to Bob, who applies a displacement by the amount  $\beta = x_- + ip_+$  to his mode  $b$ . If  $\sigma$  is the density matrix of the state to be teleported, the measurement performed by Alice is equivalent to a generalized heterodyne detection, described by the following POVM (acting on mode  $a$ ) [12]

$$\Pi_a(\beta) = \frac{1}{\pi} D(\beta) \sigma^T D^\dagger(\beta) \quad (16)$$

where  $\beta$  is a complex number,  $D(\beta) = \exp\{\beta a^\dagger - \beta^* a\}$  is the displacement operator,  $(\dots)^T$  stands for the transposition operation. The probability for the outcome  $\beta$  is

$$p(x, \tau, \eta, \beta) = \text{Tr}_{ab} \{ \varrho_{\text{IPS}} \Pi_a(\beta) \otimes \mathbb{1}_b \}, \quad (17)$$

and the conditional state is

$$\varrho_b(x, \tau, \eta, \beta) = \frac{\text{Tr}_a \{ \varrho_{\text{IPS}} \Pi_a(\beta) \otimes \mathbb{1}_b \}}{p(x, \tau, \eta, \beta)}, \quad (18)$$

which, after the displacement by Bob, becomes  $\varrho_{\text{out}}(x, \tau, \eta, \beta) = D^\dagger(\beta) \varrho_b D(\beta)$ .

For coherent state teleportation  $\sigma = |\alpha\rangle\langle\alpha|$  we have

$$\begin{aligned} \varrho_{\text{out}}(x, \tau, \eta, \beta) &= \frac{1-x^2}{p_{11}(x, \tau, \eta) p(x, \tau, \eta, \beta)} \sum_{n,m=0}^{\infty} (x\tau)^{n+m} \sum_{h,k=0}^{\text{Min}[n,m]} f_{h,k}(\tau, \eta) \\ &\times \sqrt{\binom{n}{h} \binom{n}{k} \binom{m}{h} \binom{m}{k}} \frac{e^{-|\alpha+\beta|^2} (\alpha^* + \beta^*)^{n-k} (\alpha + \beta)^{m-k}}{\sqrt{(n-k)! (m-k)!}} \\ &\times |m-h\rangle_{bb} \langle n-h|, \end{aligned} \quad (19)$$

where  $p_{11}(x, \tau, \eta)$ ,  $f_{h,k}(\tau, \eta)$  and  $p(x, \tau, \eta, \beta)$  are given by Eqs. (10), (12) and (17) respectively. Therefore the tele-

portation fidelity,  $F(x, \tau, \eta, \beta)$ , and the average fidelity,  $\bar{F}(x, \tau, \eta)$ , are given by

$$\begin{aligned} F(x, \tau, \eta, \beta) &\equiv \langle \alpha | \varrho_{\text{out}} | \alpha \rangle \\ &= \frac{1-x^2}{p_{11}(x, \tau, \eta) p(x, \tau, \eta, \beta)} \sum_{n,m=0}^{\infty} (x\tau)^{n+m} \sum_{h,k=0}^{\text{Min}[n,m]} f_{h,k}(\tau, \eta) \\ &\times \sqrt{\binom{n}{h} \binom{n}{k} \binom{m}{h} \binom{m}{k}} \frac{e^{-2|\alpha+\beta|^2} |\alpha + \beta|^{2(m+m-h-k)}}{\sqrt{(n-k)! (m-k)! (n-h)! (m-h)!}} \end{aligned} \quad (20)$$

and

$$\begin{aligned} \bar{F}(x, \tau, \eta) &\equiv \int d^2\beta p(x, \tau, \eta, \beta) F(x, \tau, \eta, \beta) \\ &= \frac{1-x^2}{2p_{11}(x, \tau, \eta)} \sum_{n,m=0}^{\infty} \left(\frac{x\tau}{2}\right)^{n+m} \sum_{h,k=0}^{\text{Min}[n,m]} 2^{h+k} f_{h,k}(\tau, \eta) \\ &\times \sqrt{\binom{n}{h} \binom{n}{k} \binom{m}{h} \binom{m}{k}} \frac{(n+m-h-k)!}{\sqrt{(n-h)! (n-k)! (m-h)! (m-k)!}}. \end{aligned} \quad (21)$$

By the substitution  $\eta \rightarrow 1$  and  $\tau \rightarrow \tau_{\text{eff}} = 1 - \eta(1 - \tau)$  Eq.

(21) can be summed, leading to the following expression

$$\bar{F}(x, \tau_{\text{eff}}) = \frac{1}{2} \frac{(1+x)(1+x\tau_{\text{eff}})(1-x^2\tau_{\text{eff}})}{(1+x^2\tau_{\text{eff}})[1+(1-\tau_{\text{eff}})x]} \frac{[2-2x\tau_{\text{eff}}+x^2\tau_{\text{eff}}]}{\{2-[2+(1-\tau_{\text{eff}})x]x\tau_{\text{eff}}\}}. \quad (22)$$

In Figure 4 we plot the average fidelity for different values of  $\tau_{\text{eff}}$ : the IPS state improves the average fidelity of quantum teleportation when the energy of the incoming TWB is below a certain threshold, which depends on  $\tau_{\text{eff}}$  and, in turn, on  $\tau$  and  $\eta$  (see Eq. (13)). When  $\tau_{\text{eff}}$  approaches unit (when  $\eta \rightarrow 1$  and  $\tau \rightarrow 1$ ), Eq. (22) reduces to the result obtained by Milburn *et al* in Ref. [11] and the IPS average fidelity (line labelled with ‘‘a’’ in Figure 4) is always greater than the one obtained with

the TWB state (1), *i.e.*

$$\bar{F}_{\text{TWB}}(x) = \frac{1+x}{2}. \quad (23)$$

However, a threshold value,  $x_{\text{th}}(\tau_{\text{eff}})$ , for the TWB parameter  $x$  appears when  $\tau_{\text{eff}} < 1$ : only if  $x$  is below this threshold the teleportation is actually improved ( $\bar{F}(x, \tau_{\text{eff}}) > \bar{F}_{\text{TWB}}(x)$ ), as shown in Figure 5. Notice that, for  $\tau_{\text{eff}} < 0.5$ ,  $\bar{F}(x, \tau_{\text{eff}})$  is always below  $\bar{F}_{\text{TWB}}(x)$ .

A fidelity larger than 1/2 is needed to show that a truly

nonlocal information transfer occurred [13]. Notice that using both the TWB (1) and the IPS state (11), this limit is always reached (Figure 4). Nevertheless, we remember that in teleportation protocol the state to be teleported is destroyed during the measurement process performed by Alice, so that the only remaining *copy* is that obtained by Bob. When the initial state carries reserved information, it is important that the only existing copy will be the Bob's one. On the other hand, using the usual teleportation scheme, Bob cannot avoid the presence of an eavesdropper, which can clone the state, obviously introducing some error [15], but he is able to verify if his state was duplicated. This is possible by the analysis of the average teleportation fidelity: when fidelity is greater than  $2/3$  [14], Bob is sure that his state was not cloned [15, 16]. The dashed line in Figure 5 shows the values  $x_{2/3}(\tau_{\text{eff}})$  which give an average fidelity (22) equal to  $2/3$ : notice that when  $x_{2/3} < x < x_{\text{th}}$  both the teleportation is improved and the the fidelity is greater than  $2/3$ . Moreover, while the condition  $\overline{F}_{\text{TWB}}(x) > 2/3$  is satisfied only if  $x > 1/3$ , for the IPS state there exists a  $\tau_{\text{eff}}$ -dependent interval of  $x$  values ( $x_{2/3} < x < 1/3$ ) for which teleportation can be considered *secure* ( $\overline{F}(x, \tau_{\text{eff}}) > 2/3$ ).

#### IV. CONCLUSIONS

We have analyzed a photon subtraction scheme similar to that of Refs. [10, 11] to modify twin-beam and improve coherent state teleportation. The difference in our

analysis is that the conditional photodetection after the beam splitters is considered inconclusive, *i.e.* performed by ON/OFF detectors which do not discriminate among the number of photons. This is closer to the current experimental situations and provides a higher conditional probability. We found that fidelity is improved compared to that of TWB-based teleportation if the initial TWB parameter is smaller than a threshold value, which in turn depends on the beam splitter transmissivity and on the quantum efficiency of the photodetectors. For realistic values of these parameters ( $\eta$  larger than 90% and  $\tau$  larger than 99%) the threshold is close to unit. In addition, there exists a interval of  $x$  for which teleportation can be considered *secure*, *i.e.* the receiver is able to check whether or not the state has been duplicated before teleportation. We conclude that IPS on TWB is a robust and realistic scheme to improve coherent state teleportation using current technology.

#### Acknowledgments

This work has been sponsored by the INFN through the project PRA-2002-CLON, by MIUR through the PRIN projects *Decoherence control in quantum information processing* and *Entanglement assisted high precision measurements*, and by EEC through the project IST-2000-29681 (ATESIT). MGAP is research fellow at *Collegio Alessandro Volta*.

- 
- [1] D. Boschi, S. Branca, F. De Martini, L. Hardy, and S. Popescu, Phys. Rev. Lett. **80**, 1121 (1998).
  - [2] D. Bouwmeester, J. -W. Pan, K. Mattle, M. Eibl, H. Weinfurter, and A. Zeilinger, Nature (London) **390**, 575 (1997).
  - [3] A. Furusawa et al., Science **282**, 706 (1998).
  - [4] S. M. Barnett, and S. J. D. Phoenix, Phys. Rev. A **44**, 535 (1991).
  - [5] G. Lindblad, Comm. Math. Phys. **33**, 305 (1973).
  - [6] S. M. Barnett, and S. J. D. Phoenix, Phys. Rev. A **40**, 2404 (1989).
  - [7] V. Vedral, M. B. Plenio, K. Jacobs, and P. L. Knight, Phys. Rev. A **56**, 4452 (1997).
  - [8] H. Araki, and E. H. Lieb, Comm. Math. Phys. **18**, 160 (1970).
  - [9] S. Popescu, and D. Rohrlich, Phys. Rev. A **56**, R3319 (1997).
  - [10] T. Opatrny, G. Kurizki, and D. -G. Welsch, Phys. Rev. A **61**, 032302 (2000).
  - [11] P. T. Cochrane, T. C. Ralph, and G. J. Milburn, Phys. Rev. A **65** 062306 (2002).
  - [12] M. G. A. Paris, A. Chizhov, O. Steuernagel, Opt. Comm. **134**, 117 (1997); P. Busch, P. Lahti, Riv. Nuovo Cim. **18**, 1 (1995); M. G A Paris, in *VII international conference on squeezed states and uncertainty relations*, E-book <http://www.wam.umd.edu/~ys/boston.html>.
  - [13] S. L. Braunstein, and H. J. Kimble, Phys. Rev. Lett. **80**, 869 (1998); S. L. Braunstein, C. A. Fuchs, and H. J. Kimble, J. Mod. Opt. **47**, 267 (2000).
  - [14] T. C. Ralph, and P. K. Lam, Phys. Rev. Lett. **81** 5668 (1998).
  - [15] N. J. Cerf, A. Ipe, and X. Rottenberg, Phys. Rev. Lett. **85** 1754 (2000).
  - [16] F. Grosshans, and P. Grangier, Phys. Rev. A **64** 010301(R) (2001).

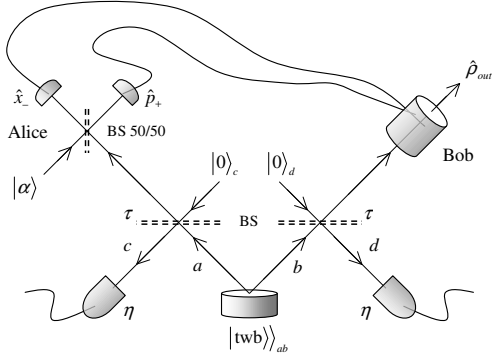

FIG. 1: Schematic diagram of continuous variable optical quantum teleportation assisted by inconclusive photon subtraction.

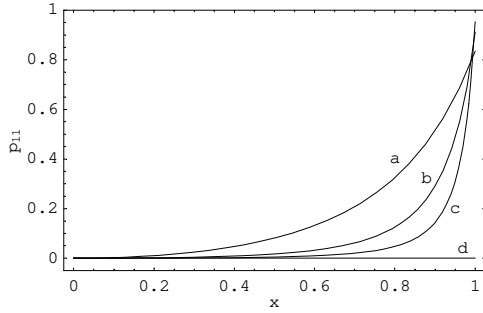

FIG. 2: Conditional probability  $p_{11}(x, \tau_{\text{eff}})$  of obtaining the IPS state as a function of the TWB parameter  $x$  for different values of the effective transmissivity  $\tau_{\text{eff}} = 0.5$  (a),  $0.8$  (b),  $0.9$  (c) and  $1$  (d).

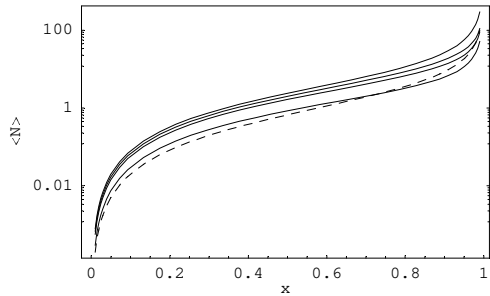

FIG. 3: Log-Linear plot of TWB (dashed line) and IPS state average photon number as a function of the TWB parameter for different values of  $\tau_{\text{eff}} = 1 - \eta(1 - \tau)$  (solid lines from top to bottom:  $\tau_{\text{eff}} = 1, 0.9, 0.8$  and  $0.5$ ).

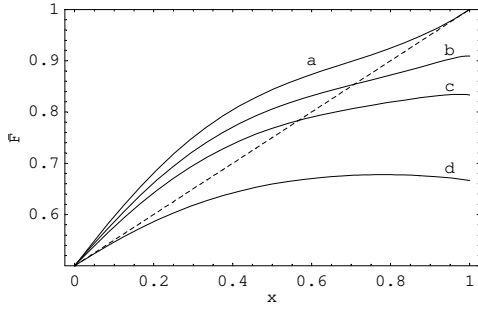

FIG. 4: IPS average fidelity  $\overline{F}(x, \tau_{\text{eff}})$  as a function of the TWB parameter for different values of  $\tau_{\text{eff}} = 1 - \eta(1 - \tau)$  ( $\tau_{\text{eff}} = 1$  (a), 0.9 (b), 0.8 (c) and 0.5 (d)); the dashed line is the average fidelity  $\overline{F}_{\text{TWB}}(x)$  for teleportation with TWB.

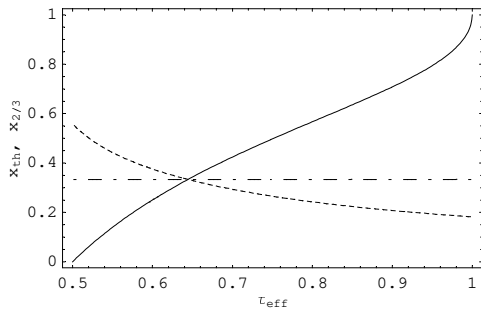

FIG. 5: Threshold value  $x_{\text{th}}(\tau_{\text{eff}})$  on the TWB parameter  $x$  (solid line): when  $x < x_{\text{th}}$  we have  $\overline{F}(x, \tau_{\text{eff}}) > \overline{F}_{\text{TWB}}(x)$  and teleportation is improved. The dot-dashed line is  $x = 1/3$ , which corresponds to  $\overline{F}_{\text{TWB}} = 2/3$ : when fidelity is greater than  $2/3$  Bob is sure that his teleported state is the best existing copy of the initial state [16]. The dashed line represents the values  $x_{2/3}(\tau_{\text{eff}})$  giving an average fidelity  $\overline{F}(x, \tau_{\text{eff}}) = 2/3$ . When  $x_{2/3} < x < x_{\text{th}}$  both the teleportation is improved and the fidelity is greater than  $2/3$ .