

# TERNARY MIXTURES OF *n*-DOCOSANE, *n*-TRICOSANE AND *n*-TETRACOSANE

H. NOUAR, D. PETITJEAN, M. BOUROUKBA  
and M. DIRAND

Institut national polytechnique de Lorraine<sup>1</sup>

MÉLANGES TERNAIRES DE *n*-DOCOSANE,  
*n*-TRICOSANE ET *n*-TÉTTRACOSANE

Les diagrammes de phases des systèmes binaires : *n*-docosane : *n*-tricosane ( $C_{22}H_{46}$  :  $C_{23}H_{48}$ ), *n*-tricosane : *n*-tétracosane ( $C_{23}H_{48}$  :  $C_{24}H_{50}$ ) et *n*-docosane : *n*-tétracosane ( $C_{22}H_{46}$  :  $C_{24}H_{50}$ ) ont été établis à partir d'analyses thermiques différentielles (ATD) et structurales. Sur la base de ces résultats, ainsi que de l'examen aux rayons X de 41 mélanges ternaires, le diagramme de phases du ternaire ( $C_{22}H_{46}$  :  $C_{23}H_{48}$  :  $C_{24}H_{50}$ ) à température ambiante est proposé. Ce travail a indiqué l'existence de domaines limités de solutions solides au voisinage des trois *n*-alcane purs, ainsi que de trois régions de phases intermédiaires orthorhombiques (notées  $\beta'_1$ ,  $\beta''_1$ ,  $\beta'_2$ ) identiques à celles observées avec les systèmes binaires. Les analyses aux rayons X ont montré que les phases  $\beta'_1$  et  $\beta'_2$  situées de part et d'autre de la phase médiane intermédiaire  $\beta''_1$  sont isostructurales, tout comme dans le cas des systèmes binaires.

TERNARY MIXTURES OF *n*-DOCOSANE,  
*n*-TRICOSANE AND *n*-TETRACOSANE

Binary phase diagrams of the systems: *n*-docosane: *n*-tricosane ( $C_{22}H_{46}$ :  $C_{23}H_{48}$ ), *n*-tricosane: *n*-tetracosane ( $C_{23}H_{48}$ :  $C_{24}H_{50}$ ) and *n*-docosane: *n*-tetracosane ( $C_{22}H_{46}$ :  $C_{24}H_{50}$ ) have been established by means of structural and differential scanning calorimetry analyses. On the basis of these results and of X-ray examination of forty one ternary mixtures, it is proposed the ternary phase diagram ( $C_{22}H_{46}$ :  $C_{23}H_{48}$ :  $C_{24}H_{50}$ ) at room temperature. This work has indicated the existence of limited terminal solid solutions near the three pure *n*-alkanes and three domains of orthorhombic intermediate phases (noted  $\beta'_1$ ,  $\beta''_1$ ,  $\beta'_2$ ) identical to those observed in the binary systems. X-ray experiments have showed that the phases  $\beta'_1$ ,  $\beta''_2$  situated on the both sides of the middle intermediate phase  $\beta''_1$ , are isostructural as in the binary systems.

MEZCLAS TERNAIRAS DE *n*-DOCOSANO,  
*n*-TRICOSANO Y *n*-TETRACOSANO

Los diagramas de fases de los sistemas binarios : *n*-docosano : *n*-tricosano ( $C_{22}H_{46}$  :  $C_{23}H_{48}$ ) : *n*-tétracosano ( $C_{23}H_{48}$  :  $C_{24}H_{50}$ ) y : *n*-docosano : *n*-tétracosano ( $C_{22}H_{46}$  :  $C_{24}H_{50}$ ) se han establecido tomando como punto de partida análisis térmicos diferenciales

(1) Laboratoire de thermodynamique des séparations,  
École nationale supérieure des industries chimiques,  
1, rue Grandville,  
54001 Nancy Cedex - France

(ATD) y estructurales. Con base a estos resultados, así como el examen por rayos X de 41 mezclas ternarias, se propone el diagrama de fases de la expresión ternaria ( $C_{22}H_{46} : C_{23}H_{48} ; C_{24}H_{50}$ ) a la temperatura ambiente. Este trabajo ha indicado la existencia de campos limitados de soluciones sólidas en las cercanías de los tres *n*-alcanos puros, así como de tres regiones de fases intermedias ortorhombicas (anotadas  $\beta'_1$ ,  $\beta''_1$ ,  $\beta'_2$ ) idénticas de aquellas observadas con los sistemas binarios. Los análisis efectuados por rayos X han demostrado que las fases  $\beta'_1$  y  $\beta'_2$  que se sitúan por ambas partes de la fase mediana  $\beta''_1$  son isoestructurales, del mismo modo que ocurre al tratarse de los sistemas binarios.

## INTRODUCTION

Studies relative to the behaviour of pure *n*-alkanes and mixtures with temperature constitute a subject of industrial and scientific interest. In fact, such works lead to the knowledge of thermodynamic and structural properties and should allow modelisation of thermodynamic properties of petroleum or wax [1-3]. Actually, there are in literature some articles which present the structural and thermodynamic characteristics of pure components and mixtures [4-9]. Some binary phase diagrams relative to the mixtures of even-even [4] and [5], odd-odd [6-8] or even-odd *n*-numbered alkanes are also proposed. Nevertheless, at our knowledge, no ternary phase diagram was already published. The purpose of this article is to present the phase diagrams of the binary systems:  $nC_{22}H_{46} : nC_{23}H_{48}$ ;  $nC_{23}H_{48} : nC_{24}H_{50}$  and  $nC_{22}H_{46} : nC_{24}H_{50}$  and also the ternary phase diagram at room temperature.

## 1 EXPERIMENTAL METHOD

All pure components come from the *Aldrich Chemical Company*. Their purity grades are given over to 99%. These values were confirmed by gas chromatography and mass spectrometry analyses. The mixtures of *n*-alkanes were obtained by quenching into nitrogen liquid of molten mixtures previously prepared by weighing of each component in the appropriate proportions.

The high velocity of the cooling allows to obtain a solid sample with a homogeneous composition in each component. Then, the samples were ground in order to obtain a powder for X-ray and thermal analyses.

As concerns the calorimetric studies, they were realised by means of *Setaram* DSC 111. This calorimeter is of type Tian Calvet. The samples examined were heated from 292 K to over the melting point at a rate of 0.5 K/min. In these conditions, the onset and end temperatures of the transitions were determined with an accuracy of  $\pm 0.5$  K.

Concerning the structural analyses, two methods were used:

- A Guinier de Wolff camera (copper radiation) was employed to observe the structural modifications at room temperature with the composition. This technique is particularly adapted to this type of



For the *n*-tricosane, three peaks can be distinguished (Fig. 1b):

- the first at low temperature corresponds to the transition:  $\beta_0$  into  $\beta'_0$ ;
- the second to the transformation of  $\beta'_0$  into  $\beta$ -RI;
- the third is attributed to the transition  $\beta$ -RI into rotator phase  $\alpha$ -RII;
- and finally, the one occurring at highest temperature represents the melting of the sample.

As concerns the mixtures, the DSC curves present three peaks: the first at lowest temperature is attributed to the transition: intermediate solid solution  $\beta'_n$  or  $\beta''_n$  into  $\beta$ -RI, the second to this of  $\beta$ -RI into  $\alpha$ -RII, and the last represents the melting of the mixture (Fig. 1c).

### 2.3 Establishment of the binary and ternary phase diagrams

Establishment of the three binary diagrams was realised by means of X-ray and calorimetric analyses of forty samples in average. Examination of X-ray patterns (at room temperature) of binary mixtures ( $C_{22}$ :  $C_{23}$ ;  $C_{23}$ :  $C_{24}$ ;  $C_{22}$ :  $C_{24}$ ) allowed to precise the equilibrium limits of the terminal solid solutions and intermediate phases and so to determine the appearance sequence of these latter versus composition [4, 5, 17, 22, 23]. It is in agreement with the general rule proposed by Dirand *et al.* [24]. The thermal behaviour and determination of the temperature transitions of the different phases were realised by the analysis of the DSC curves while X-ray diffraction was used to identify the structure of the phases previously observed. The results of these two techniques allowed us to propose the binary diagrams (Fig. 2).

As concerns the ternary mixtures, the diagram at room temperature has been established on the basis of:

- the results of examination by X-ray diffraction of forty one ternary samples whose concentration are situated in all the area of the diagram;
- the appearance sequence of the phases as function of composition which was previously determined in the three binary systems.

These results and the respect of the Palatnik and Landau's rule [25] on the adjacent phase domains lead to propose the ternary phase diagram presented on the Figure 2. One notes that the intermediate solid solution called in the binary systems  $\beta'_1$  or  $\beta'_2$  are isostructural and so indistinguishable.

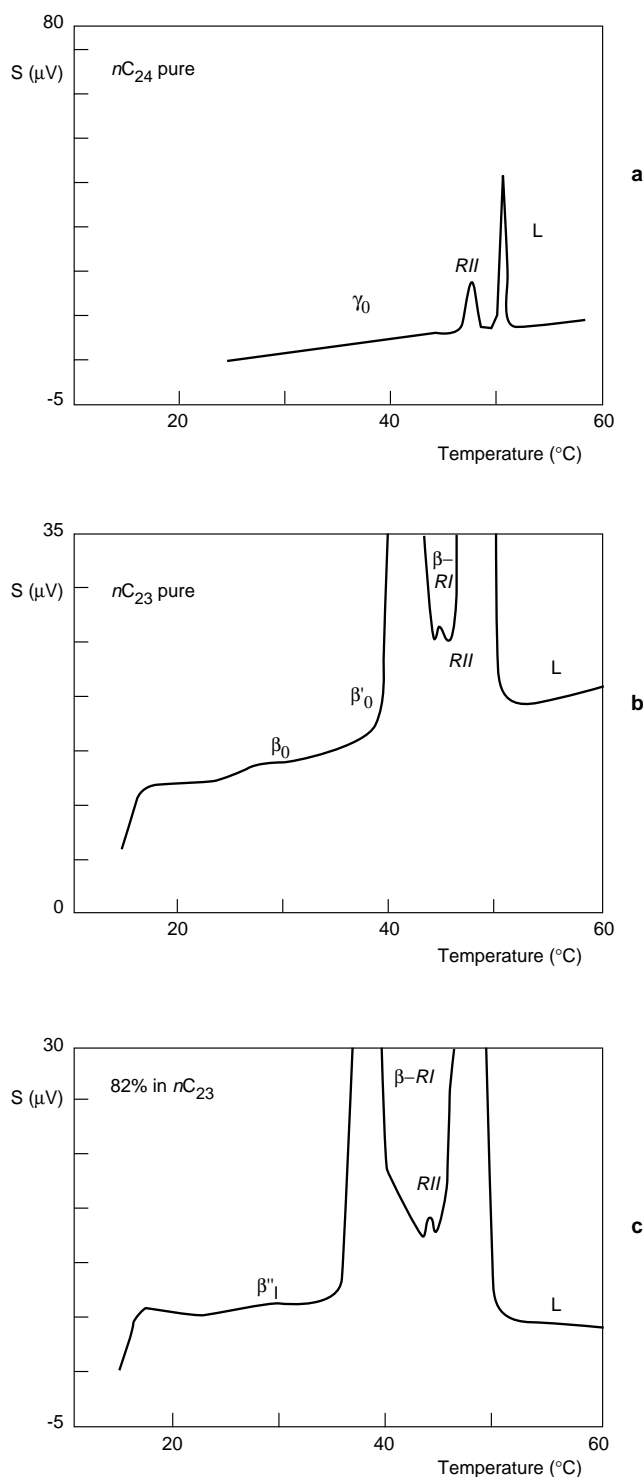

Figure 1

DSC curves of *n*-tetracosane (a), *n*-tricosane (b), the intermediate solid solution (c).

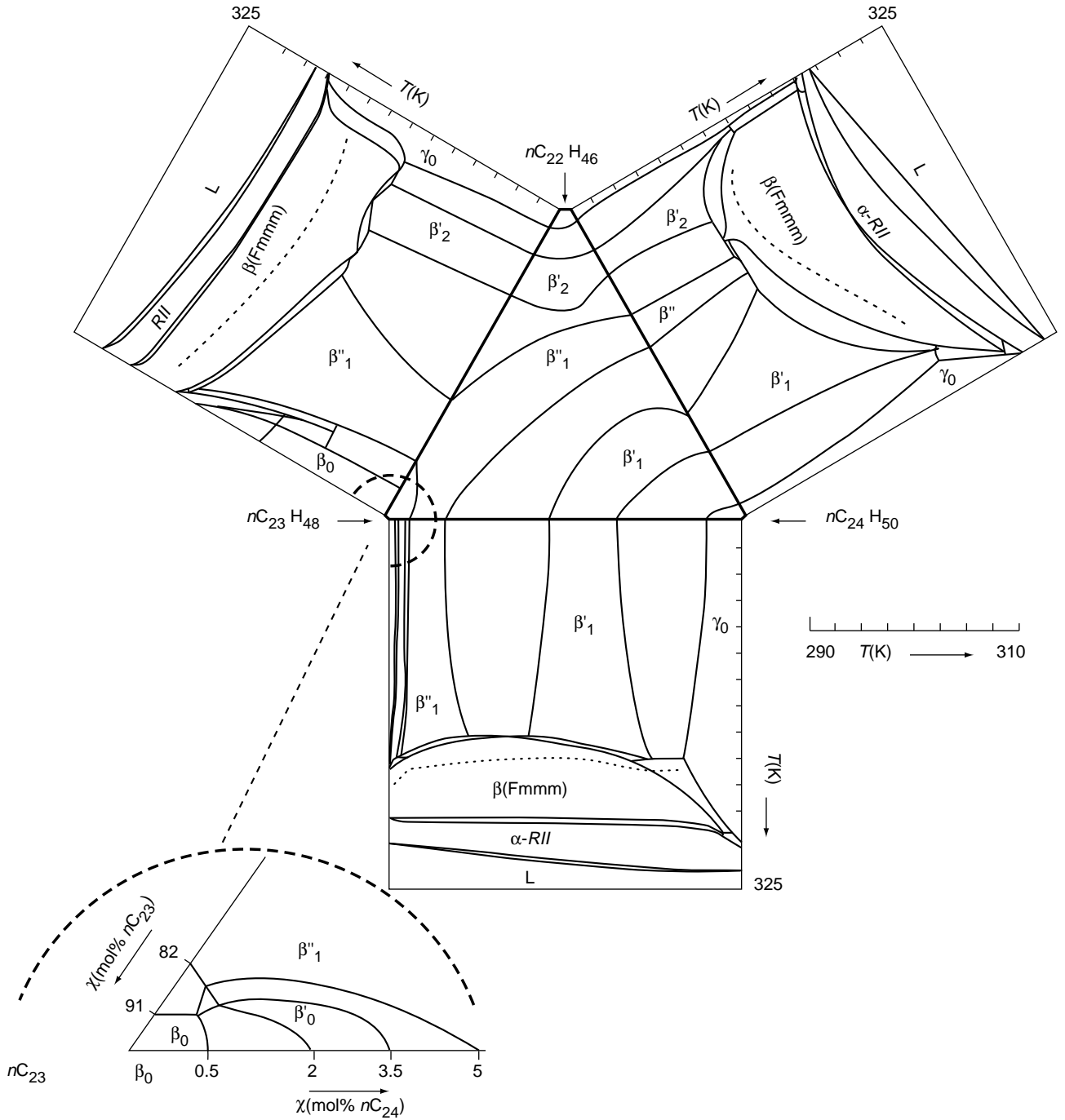

Figure 2

Binary and ternary phase diagrams (at room temperature) of the system: *n*-docosane-*n*-tricosane-*n*-tetracosane. The dotted lines indicate the onset temperature of the rotator state *RI* of the  $\beta$  phase.

## CONCLUSION

The ternary diagram of consecutive *n*-docosane *n*-tricosane and *n*-tetracosane was determined at room temperature. It shows the existence of limited terminal solid solutions near pure components and three domains of intermediate phases. Two of them ( $\beta'_1$ ,  $\beta'_2$ ) which are isostructural, are situated on both sides of the third noted  $\beta''_1$ . Moreover this study confirms that the intermediate solid solutions observed in the binary system exist also in the ternary mixtures of consecutive *n*-alkanes.

At the present time, this study goes on in the laboratory in order to determine the ternary diagram in temperature. One can think that the thermal behaviour of the orthorhombic intermediate phases is similar to this observed in the binary system.

## REFERENCES

- 1 Barbillon P., Schuffenecker L., Dellacherie J., Balesdent D. and Dirand M. (1991) *J. Chim. Phys.*, 88, 91.
- 2 Ghogomu P.M., Dellacherie J. and Balesdent D. (1989) *J. Chem. Thermo.*, 21, 925.
- 3 Ghogomu P.M., Dellacherie J. and Balesdent D. (1990) *Thermochim. Acta*, 15, 241.
- 4 Achour-Boudjema Z., Bouroukba M. and Dirand M. (1996) *Thermochim. Acta*, 279, 243.
- 5 Achour-Boudjema Z., Bourdet J.B., Petitjean D. and Dirand M. (1995) *J. Mol. Struct.*, 354, 197.
- 6 Luth H., Nyburg S.C., Robinson P.M. and Scott H.G. (1974) *Mol. Cryst. Liq. Cryst.*, 27, 337.
- 7 Jouti B., Petitjean D., Provost E., Bouroukba M. and Dirand M. (1995) *J. Mol. Struct.*, 356, 191.
- 8 Jouti B., Provost E., Petitjean D., Bouroukba M. and Dirand M. (1996) *J. Mol. Struct.*, 382, 49.
- 9 Denicolo I., Craievich A.F. and Doucet J. (1984) *J. Chem. Phys.*, 80, 12, 6200.
- 10 Clydesdale G. and Roberts K.J. (1991) *AiChe Symposium Series*, 284, 87, 130.
- 11 Heyding R.D., Russel K.E., Varty T.L. and St-Cyr D. (1990) *Powder Diffraction*, 5, 2, 93.
- 12 Craig S.R., Hastie G.P., Roberts K.J. and Sherwood J.N. (1994) *J. Mater. Chem.*, 4, 6, 977.
- 14 Ungar G. (1983) *J. Phys. Chem.*, 87, 689.
- 15 Doucet J., Denicolo I., Craievich A.F. and Collet A. (1981) *J. Chem. Phys.*, 75, 3, 1523.
- 16 Doucet J., Denicolo I., Craievich A.F. (1983) *J. Chem. Phys.*, 78, 3, 1465.
- 17 Hasnaoui N., Dellacherie J., Schuffenecker L. and Dirand M. (1988) *J. Chim. Phys.*, 85, 6, 676.
- 18 Achour-Boudjema Z., Barbillon P., Bouroukba M. and Dirand M. (1992) *Thermochim. Acta*, 204, 187.
- 19 Mazee W.M. (1958) Am. Chem. Soc., *Meeting Symp. of Div. Pet. Chem.*, Chicago 1993.
- 20 Basson I. and Reynhardt E.C. (1991) *J. Chem. Phys.*, 95, 2, 1215.
- 21 Srivastava S.P., Handoo J., Agarwal K.M. and Joshi G.S. (1993) *J. Phys. Chem. Solids*, 54, 6, 639.
- 22 Nouar H., Petitjean D., Bourdet J.B., Bouroukba M. and Dirand M. (1997) *Thermochim. Acta*, 293, 87.
- 23 Nouar H., Petitjean D., Bourdet J.B. and Dirand M. (1997) *J. Mol. Struct.*, 415, 277.
- 24 Dirand M., Achour Z., Sabour A., Gachon J.C. (1996), *Mol. Cryst. Liq. Cryst.*, 275, 293.
- 25 Palatnik L.S. and Landau A.I. (1964) *Phase Equilibria in Multicomponent Systems*. Holt, Rinehart and Winston, New York.

*Final manuscript received in December 1997*