

 Open access • Proceedings Article • DOI:10.2514/6.1986-654

Testing of 30-GHz low noise receivers — [Source link](#)

M. J. Conroy, R. J. Kerczewski

Institutions: Glenn Research Center

Published on: 01 Jan 1986

Topics: Communications satellite, Telecommunications link, Low-noise amplifier and Noise figure

Related papers:

- [Test results for 27.5- to 30-GHz communications satellite receivers](#)
- [W/V-Band RF Propagation Experiment Design](#)
- [Communications transponder performance for Japanese Communications Satellite-2 and prospects for future systems](#)
- [30/20 GHz band fixed earth station](#)
- [Spectral reuse in 12 GHz satellite communication systems](#)

Share this paper:    

View more about this paper here: <https://typeset.io/papers/testing-of-30-ghz-low-noise-receivers-3afmck6ha7>

General Disclaimer

One or more of the Following Statements may affect this Document

- This document has been reproduced from the best copy furnished by the organizational source. It is being released in the interest of making available as much information as possible.
- This document may contain data, which exceeds the sheet parameters. It was furnished in this condition by the organizational source and is the best copy available.
- This document may contain tone-on-tone or color graphs, charts and/or pictures, which have been reproduced in black and white.
- This document is paginated as submitted by the original source.
- Portions of this document are not fully legible due to the historical nature of some of the material. However, it is the best reproduction available from the original submission.

Testing of 30-GHz Low Noise Receivers

Martin J. Conroy
Lewis Research Center
Cleveland, Ohio

and

Robert J. Kerczewski
ANALEX Corporation
Cleveland, Ohio

(NASA-TM-87171) TESTING OF 30-GHz LOW NOISE
RECEIVERS (NASA) 24 F HC A02/MF A01
CSCL 20N

N86-13627

Unclas
G3/32 04969

Prepared for the
Eleventh Annual Communication Satellite Systems Conference
sponsored by the American Institute of Aeronautics and Astronautics
San Diego, California, March 16-20, 1986

NASA

1986
RECEIVED
NASA STI FACILITY
ACCESS DEPT.

TESTING OF 30-GHZ LOW NOISE RECEIVERS

Martin J. Conroy
Space Communications Division
National Aeronautics and Space Administration
Lewis Research Center
Cleveland, Ohio 44135

and

Robert J. Kerczewski
ANALEX Corporation
Lewis Research Center
Cleveland, Ohio 44135

Abstract

NASA-Lewis sponsored studies of the growth in communications traffic have indicated that the frequency spectrum allocated to fixed-service satellites at the C and Ku bands will reach saturation by the early 1990's. The next higher frequency bands allocated for communications satellites are 27.5 to 30 GHz for the uplink and 17.7 to 20.2 GHz for the downlink. Current plans for developing satellite systems that use these bands include a NASA demonstration satellite (ACTS). One of the components identified as critical to the success of that mission is a 27.5 to 30 GHz satellite receiver.

In response to that identification, NASA has sponsored the development of such a receiver to the proof-of-concept (POC) level. Design and fabrication of such POC model receivers was carried out under parallel contracts awarded to LNR Communications, Inc. of Hauppauge, New York and to ITT Defense Communications Division of Nutley, New Jersey. The most significant of the performance goals were a 5 dB maximum noise figure, a 2.5 GHz passband, and 20 dB RF to IF gain.

Following delivery of hardware from each of the contractors, an in-house test program was undertaken at NASA Lewis in order to verify the contractor-reported performance and to provide a comparison of the two receivers under identical test conditions. The present paper reports the results of those tests.

Introduction

Table I lists the performance requirements for the proof-of-concept receivers. The input frequency band (27.5 to 30 GHz) is established by international agreement. The output band was not explicitly specified, thereby allowing the receiver designers freedom to apply the results of their design studies to optimize receiver performance. The other requirements were established by estimating the performance attainable by state-of-the-art techniques without imposing restrictive specifications on one variable at the expense of another. Photographs of the receivers are shown in Figs. 1 and 2.

The block diagram of the LNR receiver is shown in Fig. 3. The receivers use image-enhanced mixers as the input stage. In these circuits the image frequency band is terminated in a reactance that reflects the power at the image frequency band to the mixer for conversion by the L.O. to the desired IF band. This technique provides an

improvement in signal strength at no increase in noise level. The first stage of the IF amplifier has a low noise figure, less than 2 dB, and makes a significant contribution to the receiver noise figure.

The LNR receivers use a 500-MHz crystal oscillator as the reference signal. This oscillator is located in the separate dc/dc converter box and provides sufficient signal level to drive the local oscillator multipliers of three receivers simultaneously. When one receiver is in operation, the unused ports of the power divider are terminated with 50 Ω loads. The reference oscillator signal is multiplied to 6 GHz by a step recovery diode, and is mixed with a sample of the 5.95 GHz voltage controlled oscillator signal. The resulting 50 MHz difference signal is compared with the 50 MHz signal produced by dividing the 500 MHz reference oscillator signal by ten. The output of the 50 MHz phase detector controls the 5.95 GHz voltage controlled oscillator. The 5.95 GHz signal is multiplied by four in a varactor multiplier and provides the 23.8 GHz local oscillator signal for the image-enhanced mixer. The output of this mixer is fed to a three-stage FET intermediate frequency amplifier. Bias voltages and monitoring circuits are provided within the receiver.

Figure 4 shows a block diagram of the ITT receiver. The reference signal for the multiplier chain is provided by a Hewlett-Packard 8614B klystron oscillator. The reference signal is multiplied by a times-three and a times-five multiplier to produce the local oscillator signal for the image-enhanced mixer. A synthesized signal generator is not recommended for this purpose because the generator phase noise modulates the receiver input signal. Each receiver design is described in detail in the respective contractor reports.^{1,2}

The following tests were performed on each receiver: gain, noise figure, 1-dB compression point, third-order intermodulation, image rejection, AM-PM conversion, group delay, gain slope, input voltage standing-wave ratio (VSWR), output VSWR, dc power, and output spectrum. The measurement techniques and methods were similar to those used by the contractors. Results of the tests are in close agreement with the manufacturer's test results.

Gain and Noise Figure

The gain and the noise figure of the LNR receivers were measured with the test equipment configured as shown in Fig. 5. Because the output

frequency band of the receivers (3.7 to 6.2 GHz) is greater than the maximum input frequency (1.5 GHz) of the noise figure meter, and external downconverter was used. The downconverter configuration complied with the recommendations in the noise figure meter manufacturer's application note.³ The downconverter local oscillator was stepped from 2.5 to 4.9 GHz in order to provide a 1.3-GHz input frequency to the noise figure meter. The downconverter local oscillator and the noise figure meter were controlled by a desktop computer. The gain and the noise figure of the ITT receivers were measured with the same test equipment configuration used for the LNR receivers except that a cavity-tuned signal generator was used to perform the local oscillator reference function for the receiver.

Both solid-state and gas-discharge noise sources are available in the 26.5 to 40-GHz band. Solid-state noise sources with built-in attenuators provide an excess noise ratio (ENR) that is the same as the ENR for gas tubes. However, the variation in ENR in the gas tube over the waveguide band is one-third of the ENR variation of the solid-state sources. For this reason the gas-discharge noise source was selected for the noise figure tests.

The noise figure meter and the downconverter were calibrated by feeding a noise signal from an Hewlett Packard 34b noise source to the input of the downconverter mixer. The values of ENR that were provided by the noise source manufacturer were set into the noise figure meter. This procedure calibrated the system except for the 30-GHz gas-discharge noise source. The gas-discharge noise source and the receiver were then connected to the downconverter mixer, and the single ENR value of the gas-discharge noise source was set into the noise figure meter. When measurements were made with this method, the uncertainty was due to the combination of the gas-tube ENR uncertainty (± 0.5 dB) and the noise figure meter uncertainty (± 0.1 dB). The worst-case uncertainty was then ± 0.6 dB, or, if root-sum-square is used, ± 0.51 dB. Also, the calibration of the gas-tube ENR is given by the manufacturer and not the National Bureau of Standards because the NBS does not provide a noise calibration service in the 27.5 to 30-GHz band.

Plots of the gain and the noise figure for LNR receiver 2 are shown in Figs. 6 and 7. The plots for the other two LNR receivers are similar. Maximum, minimum, median, and passband variation values for the gain and the noise figure of each receiver are given in Table II along with similar measurements made by the contractor. Receiver 3 has the least variation (3.3 dB) in gain within the passband and receiver 2 has the largest variation (4.6 dB). The NASA Lewis-measured gain variations differed from the LNR-measured gain variations by no more than 0.7 dB. The mean gain of the three receivers is 19.95 dB, which should be rounded to 20 dB.

When the minimum noise figure measurements made at NASA Lewis are compared with the minimum noise figure measurements made by LNR, the largest difference is 0.6 dB. This is within the ± 0.6 dB instrumentation uncertainty. When similar comparisons are made in the maximum noise figures,

receivers 1 and 3 fall within the ± 0.51 dB rss uncertainty. The maximum noise figure difference (1.5 dB) for receiver 2 is greater than the worst-case uncertainty.

Spectra of the LNR receiver output show a number of spurious responses in the receiver passband. The noise figure measurements were made in the frequency slots between the spurious responses, and thus the noise figure values were not affected by these responses.

The gain and the noise figure for ITT receiver 1 is shown in Figs. 8 and 9. The measurements taken at NASA Lewis are compared in Table III with the measurements performed at ITT. All measurements agree within 0.7 dB.

Compression Point

Figure 10 is a block diagram of the equipment used for the 1-dB compression point test. The 1-dB compression point was measured at 27.5, 28.75, and 30 GHz for each LNR receiver. The procedure was to set the power input to the receiver at -15 dBm and to record the receiver IF power output. The input power was then increased 5 dB by means of the variable attenuator. The receiver power output was measured and the difference between the two output power measurements was recorded. The process was repeated in 1-dB increments of input power until the 5 dB change in power input produced an output power change of 4 dB.

All of the compression point measurements referenced to the output are greater than 10 dBm. The measurements made at NASA Lewis are in close agreement with the manufacturer's measurements.

The same equipment configuration and procedure were used to measure the 1 dB compression point of the ITT receivers. The measurements show that the receivers are linear up to the 10 dBm output level. Upon the manufacturer's recommendation, no signals greater than that required to produce 10 dBm power output were applied to the input. These measurements were made at the center of the band, 28.75 GHz. The results agree with those reported by ITT.

Curves of power output versus power input for all of the receivers are shown in Figs. 11 and 12. The tests were performed at the center frequency of the uplink band (28.75 GHz).

Third-Order Intermodulation

The equipment used for measuring the third-order intermodulation products is shown in Fig. 13. The test specification was that two equal signals of -30 dBm at the receiver input, separated by 0.2 GHz or less, should produce third-order intermodulation products that are more than 50 dB below either input signal. An intermodulation product test summary for the five receivers is given in Table IV. The intermodulation products for all of the receivers are more than 60 dB below the carrier, a margin of 10 dB beyond the specification.

Image Response

The equipment setup of the image response test is shown in Fig. 14. The receiver performance requirement for image rejection is a minimum of 15 dB. The image frequency band is 20.4 to 22.9 GHz for the ITT receiver and 17.6 to 20.1 GHz for the LNR receiver. The frequency selected for the image rejection test at NASA Lewis was at the high end of the image passband. Slight adjustments were made to the LNR image test frequency to assure that the image response would fall between the receiver spurious responses. The results of the image response test are shown in Table V. All of the receivers show a response of 55 dB or more below the level of the signal at the image frequency.

Amplitude Modulation - Phase Modulation Conversion

The AM-PM requirement for the receivers was less than 1 deg/dB for input carriers of signal level no greater than -70 dBm. The technique used to make the measurements was adapted from a technique used to measure the AM-PM conversion of traveling-wave tubes (ref. 4). The block diagram of the instrumentation is identical to that used for the third-order intermodulation tests (Fig. 13). In the third-order intermodulation tests the input signals were of equal amplitude. In the AM-PM tests the input signals differ in amplitude by 30 dB. The signal-frequencies of the two generators were nominally 28.5 and 28.7 GHz. The actual signal-frequencies were set to values that would avoid coincidence with the spurious output responses of the LNR receivers, would occupy a portion of the passband that had an amplitude variation of less than 1 dB, and would be close to the center of the passband. The measurements were made at a signal input level of -15 dBm. This was 55 dB above the required level. The measurements were not made at -70 dBm because the responses to the input signals would have been well below the noise level of the spectrum analyzer. The results of these tests are shown in Table VI. The measured values of AM-PM conversion are within the requirements. LNR calculated the AM-PM conversion factor by using the third-order intercept point. They obtained AM-PM conversion factors of 0.5 to 0.8 deg/dB, at signal input of -15 dBm. ITT measured the receiver response to the two-signal input and calculated the AM-PM conversion factor. Their results were less than 0.1 deg/dB and are comparable to the results obtained at NASA Lewis. (Measurements were not made on LNR receiver 2 because of an equipment failure.)

Group Delay

A block diagram of the group delay measurement method is shown in Fig. 15. The measurement technique and derivation are given in Ref. 5. Before the receiver and the receiver output detector were connected, a calibrating signal was obtained by connecting a waveguide-mount crystal detector in place of the receiver and the coaxial crystal detector. After calibration the waveguide crystal detector was removed. The receiver and the coaxial crystal detector were then inserted and the signal generator frequency was swept from

27.5 to 30 GHz. The group delay data for the five receivers are shown in Table VII. The receivers meet the 5 nsec group delay ripple requirement.

Neither manufacturer measured the group delay of their receivers. LNR calculated the group delay ripple of the 5-pole Chebyshev IF filter. The calculated ripple is 0.346 nsec which is about one-tenth of the measured group delay ripple in the LNR receivers.

Gain Slope

The gain-slope requirement for the receivers was 0.5 dB/10 MHz. To test the receivers for this requirement, a leveled -23 dBm sweep was fed to the receiver input, and spectrum analyzer plots of the receiver IF output were made. From inspection of the plots, the portions of the curves that exhibited the greatest slope were selected for gain-slope calculations. Figure 16 shows the gain-slope measurement for LNR receiver 2. LNR receiver 1 showed the largest gain-slope measurement. This was due to a resonance in the mixer current monitor circuit, which did not appear in LNR receivers 2 and 3. Table VIII summarizes the gain-slope measurements. LNR receivers 2 and 3 and the ITT receivers meet the requirements.

Input Standing-Wave Ratio

The equipment configuration that was used for measuring the standing wave ratio of the receiver input port is shown in Fig. 17. A spectrum analyzer is used as the reflected power indicator because it will display both the reflected power in the receiver passband and the local oscillator signal that feeds through the mixer to the receiver input port. A conventional power meter would add both signals and give an erroneous measurement of standing wave ratio. The standing wave ratio of ITT receiver 2 is shown in Fig. 18, and the NASA Lewis measurements of LNR receivers are shown in Fig. 19. The requirement of 1.25:1 was met by both contractors only in a portion of the input frequency band.

Output Voltage Standing-Wave Ratio

The standing wave ratio at the output of the receivers was measured by an automatic network analyzer. All of the receivers met the 1.8:1 specification. Table IX shows the measurements of maximum output voltage standing wave ratios made at NASA Lewis. Measurements by the respective manufacturers were somewhat less than the NASA Lewis measurements. Since the specification had been met, the differences between NASA Lewis measurements and the contractor measurements were not investigated.

Direct-Current Power

LNR provides a dc power conditioner to supply ± 15 and ± 5 V for operation of the receiver, and to provide power for the 500-MHz crystal oscillator that is located in the power conditioning box. The steady-state current drawn from the 28-V supply is 700 mA for receiver 1, 750 mA for receiver 2, and 640 mA for receiver 3. The current drawn by the ITT receivers is 225 mA for each receiver. The ITT power conditioner was equipped with a power-sequencing switch that

applied gate bias to the amplifiers before drain voltage was applied. As a result there is no turn-on transient in the ITT receivers.

Output Spectrum

To determine the spurious responses that were generated in the receivers, spectrum analyzer plots were obtained at the output of the receivers when no signal was present at the receiver input. The output spectrum from ITT receiver 1 is shown in Fig. 20. In the ITT receiver two responses are shown. Both are outside the IF passband. The signal at 5.04 GHz is due to the third harmonic of the local oscillator signal. The cause of the response at 2.25 GHz was not determined, and this response did not appear in ITT receiver 2.

Figure 21 shows the spurious responses that exist at the output of LNR receiver 1. The frequency and level of the responses are identified. The spurious responses occur at multiples of 500 MHz, and are attributed by the manufacturer to the step recovery diode. To reduce the effects, internal compartment shields were applied to receiver 1. No further steps were taken to solve the problem because the program had come to its end.

Conclusions

The receivers supplied by both contractors met most of the requirements. Both contractors approached the noise figure requirement of 5 dB near the midpoint of the receiver passband, but

the noise figure increased by 3 to 5 dB at the high and low ends of the passband. The receiver gain requirement was met only in portions of the passband. Variation of gain within the passband was greater than expected.

The LNR receivers had a set of spurious responses within the receiver passband. It is expected that future models of the receiver will not display this problem. All of the receivers meet the intent of the proof-of-concept contracts.

References

1. Steffek, L.J., and Smitn, D.W., "The 30 GHz Communications Satellite Low Noise Receiver," LNR Communications, Inc., Hauppauge, N.Y., LNR-400, Oct. 1983. (NASA CR-168254)
2. Dewland, J.F., and Goldman, H., "30/20 GHz Communications Satellite Low Noise Receiver," ITT Defense Communications, Nutley, N.J., Oct. 1983. (NASA CR-168184)
3. Applications and Operation of the 8970A Noise Figure Meter. Product Note 8970A-1, Hewlett Packard, 1982.
4. Laico, J.P., McDowell, H.L., and Moster, C.R., "A Medium Power Traveling-Wave Tube for 6,000-Mc Radio Relay," Bell System Technical Journal, Vol. 35., Nov. 1956, pp. 1285-1346.
5. Swept-Frequency Group Delay Measurements. Application Note 77-4, Hewlett Packard, 1968.

TABLE I. - PERFORMANCE REQUIREMENTS

Input radiofrequency band, GHz	27.5 to 30
Output intermediate frequency, GHz	3 to 8
Noise figure, dB	5
Radio- to intermediate-frequency gain, dB	20
In-band overdrive for no permanent degradation, dBm	-10
Gain variation, dB	+1
Gain slope, dB per 10 MHz	+0.5
Voltage standing-wave ratio (VSWR) input (max.)	1.25
Voltage standing-wave ratio (VSWR) output (max.)	1.8
Group delay:	
Parabolic, ns/mHz ² /100 MHz	+0.1
Ripple, ns p-p (max.)	5
Image rejection, at IF output, dB	15
AM-PM conversion for input carriers up to -70 dBm, deg/dB	1
dc power (+10 percent), V dc	28
Connectors:	
Input	WR 28
Output	SMA
dc	Optional

TABLE II. - LEWIS AND LNR MEASUREMENTS
OF GAIN AND NOISE FIGURE

	Lewis measurement, dB	LNR measurement, dB
Gain		
Receiver 1:		
Maximum gain	21.8	21.8
Minimum gain	18.0	18.7
Median	19.9	20.25
Passband variation	3.8	3.1
Receiver 2:		
Maximum gain	21.6	21.8
Minimum gain	17.0	16.8
Median	19.3	19.3
Passband variation	4.6	5.0
Receiver 3:		
Maximum gain	22.3	21.8
Minimum gain	19.0	18.8
Median	20.65	20.3
Passband variation	3.3	3.0
Mean, three receivers	19.95	19.95
Noise figure		
Receiver 1:		
Minimum	5.8	5.2
Maximum	8.5	7.5
Median	7.15	6.35
Variation	2.7	2.3
Receiver 2:		
Minimum	6.3	6.1
Maximum	10.8	9.3
Median	8.55	7.7
Variation	4.5	3.2
Receiver 3:		
Minimum	5.9	5.3
Maximum	8.5	7.5
Median	7.2	6.4
Variation	2.6	2.2
Mean, three receivers	7.6	6.8

TABLE III. - LEWIS AND ITT MEASUREMENTS
OF GAIN AND NOISE FIGURE

	Lewis measurement, dB	ITT measurement, dB
Gain		
Receiver 1:		
Maximum	19.8	20.4
Minimum	14.7	15.4
Median	17.3	17.9
Passband variation	5.1	5.0
Receiver 2:		
Maximum	19.3	19.3
Minimum	14.5	15.0
Median	16.9	17.2
Passband variation	4.8	4.3
Noise figure		
Receiver 1:		
Maximum	9.9	9.4
Minimum	6.1	5.4
Median	8.0	7.4
Passband variation	3.8	4.0
Receiver 2:		
Maximum	9.2	8.95
Minimum	6.8	6.2
Median	8.0	7.55
Passband variation	2.4	2.75

TABLE IV. - INTERMODULATION PRODUCT SUMMARY

Receiver	Median output signal level, dBm	Median intermodulation level, dBm	Level difference, dB
LNR 1	-10.9	-72.5	61.6
LNR 2	-12.5	-73.4	60.9
LNR 3	-10.5	-71.3	60.8
ITT 1	-11	-75.5	64.5
ITT 2	-12	-74	62.0

TABLE V. - IMAGE RESPONSE SUMMARY

Receiver	Input		Output		Response, dB
	Frequency, GHz	Level, GHz	Frequency, GHz	Level, dBm	
LNR 1	20.1	-20	3.7	-84	64
LNR 2	20.1	↓	3.7	<-85	>65
LNR 3	20.1		3.7	<-85	>65
ITT 1	22.9		2.3	-75	55
ITT 2	22.9	↓	2.3	-77	57

TABLE VI. - AM-PM
CONVERSION FACTOR

Receiver	AM-PM conversion factor at -15-dBm input power, deg/dB
LNR 1	0.3
LNR 2	---
LNR 3	.5
ITT 1	.19
ITT 2	.15

TABLE VII. - GROUP DELAY RIPPLE

[Ripple requirements, 5 nsec peak to peak.]

Receiver	Ripple, nsec p-p	Frequency range, GHz
LNR 1	3.4	28.0-30
LNR 2	3.8	27.5-30
LNR 3	4.6	27.5-30
ITT 1	4	27.5-30
ITT 2	4	27.5-30

TABLE VIII. - SUMMARY OF GAIN
SLOPE MEASUREMENTS

Receiver	Intermediate frequency, GHz	Gain-slope, dB/10 MHz
LNR 1	4.04	-0.485
LNR 2	4.88	-.16
LNR 3	4.69	-.06
ITT 1	2.5	-.2
ITT 2	2.45	-.19

TABLE IX. -
OUTPUT
STANDING
WAVE
RATIO

Receiver	VSWR
LNR 1	1.7:1
LNR 2	1.7:1
LNR 3	1.7:1
ITT 1	1.4:1
ITT 2	1.4:1

ORIGINAL PAGE IS
OF POOR QUALITY

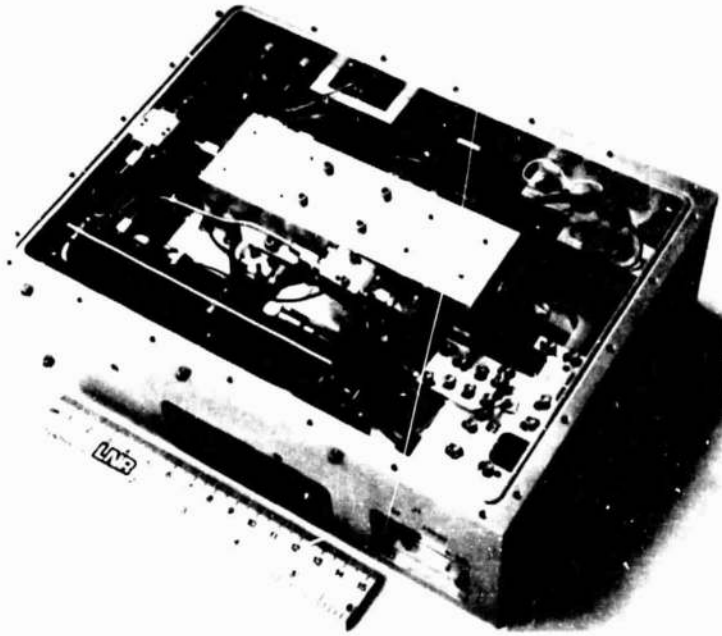

Figure 1. INR receiver.

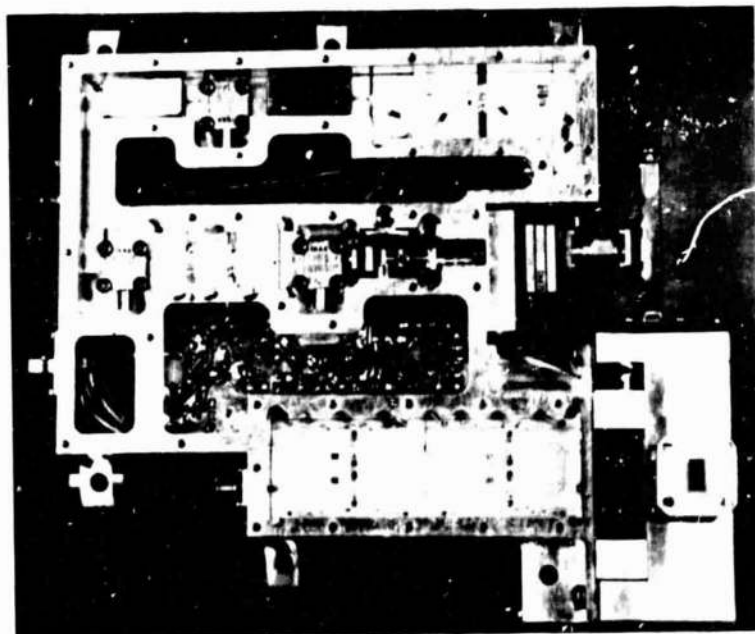

Figure 2. MT receiver.

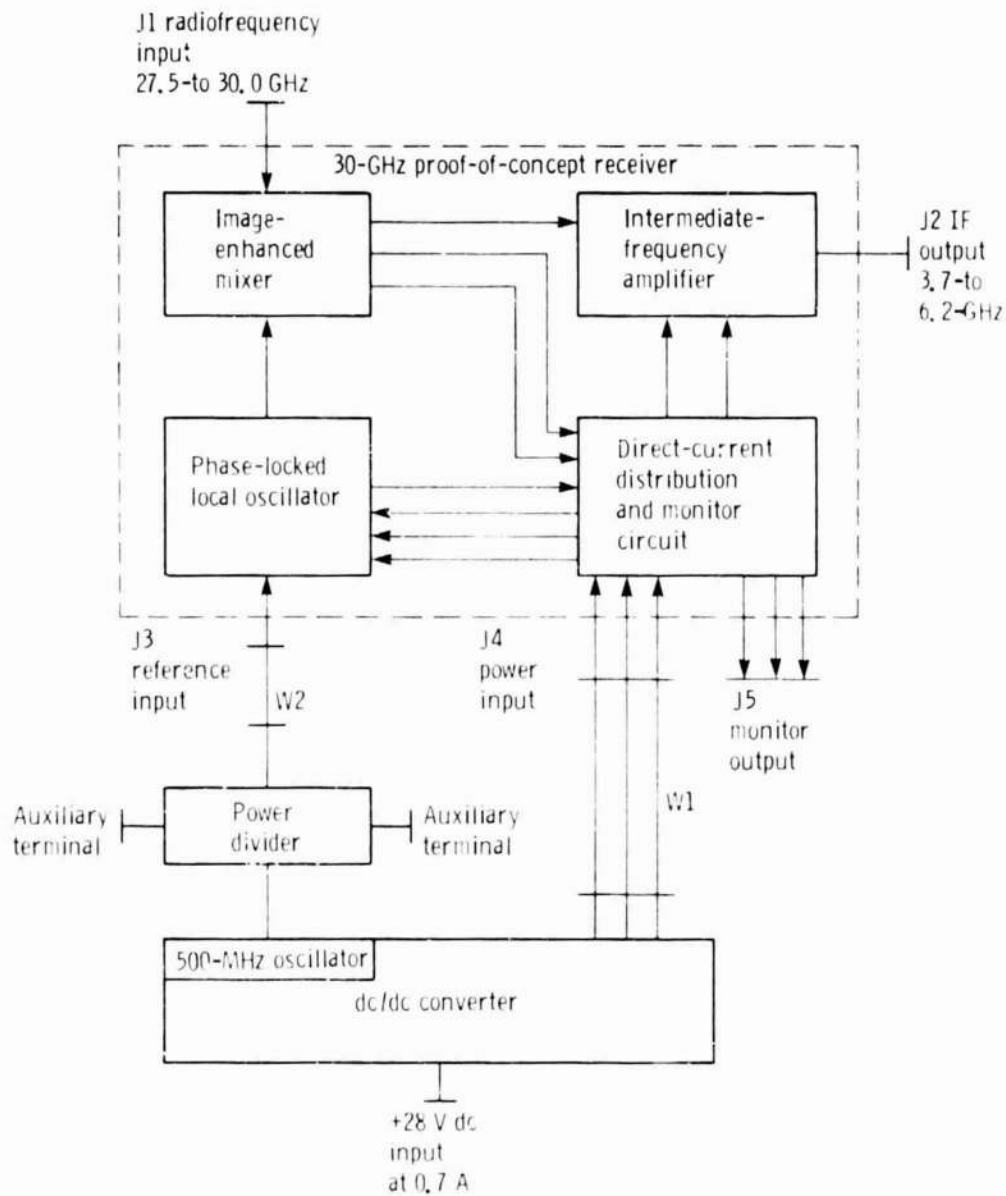

Figure 3. - Block diagram of LNR receiver.

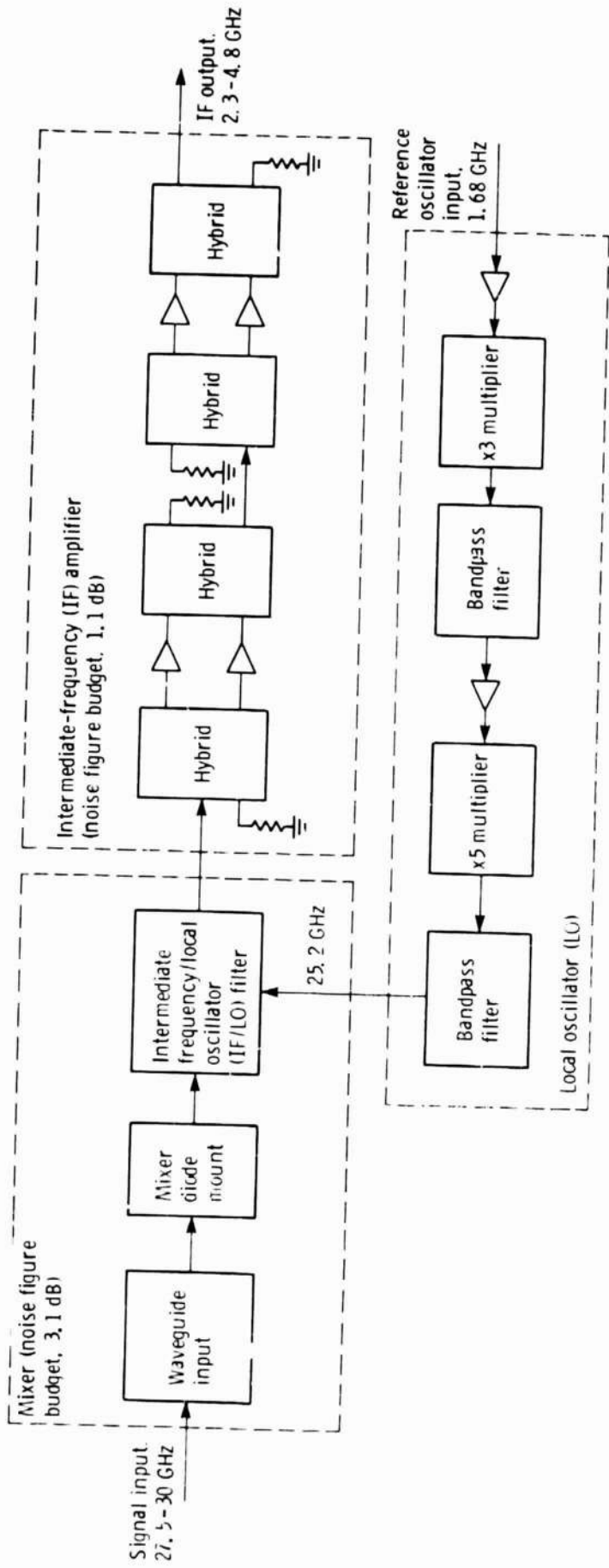

Figure 4. - Block diagram of ITT receiver.

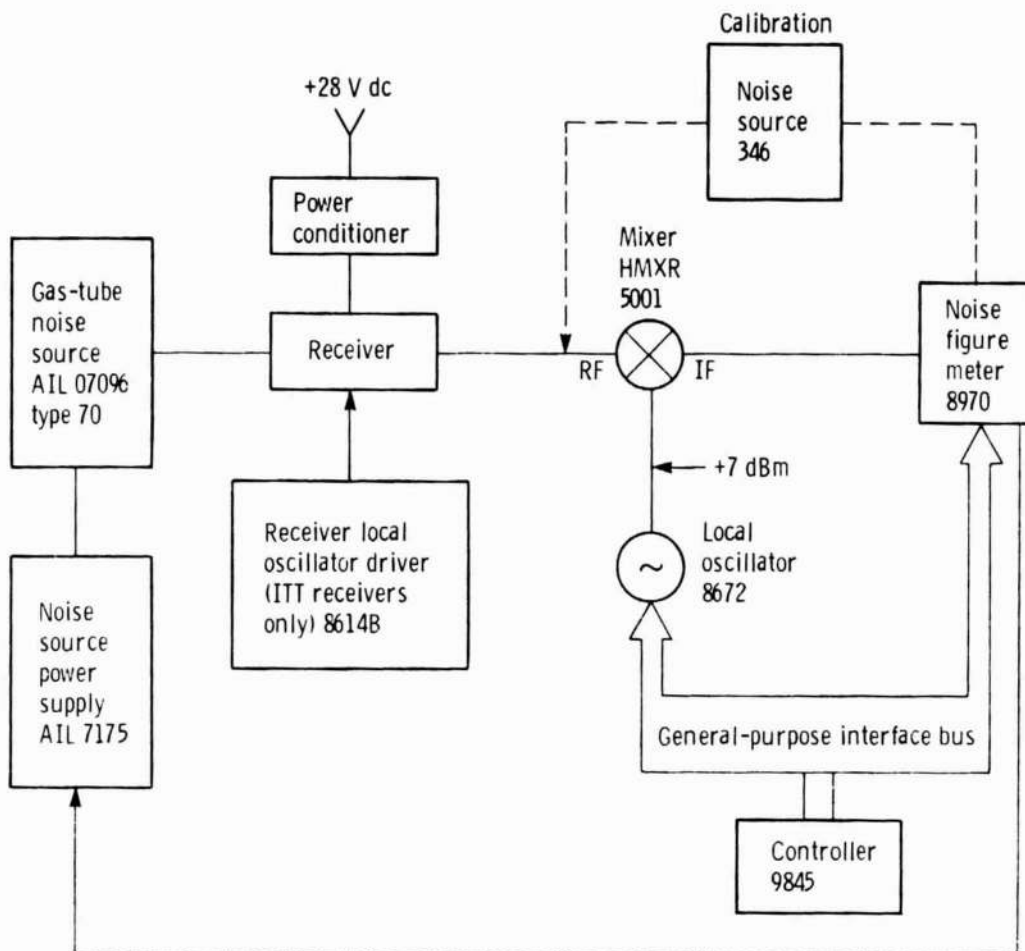

Figure 5. - Block diagram of gain and noise figure tests.

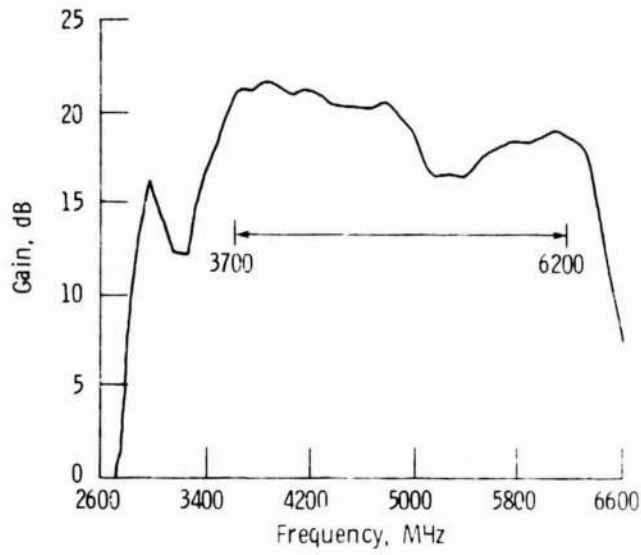

Figure 6. - Gain versus intermediate output frequency, LNR receiver 2.

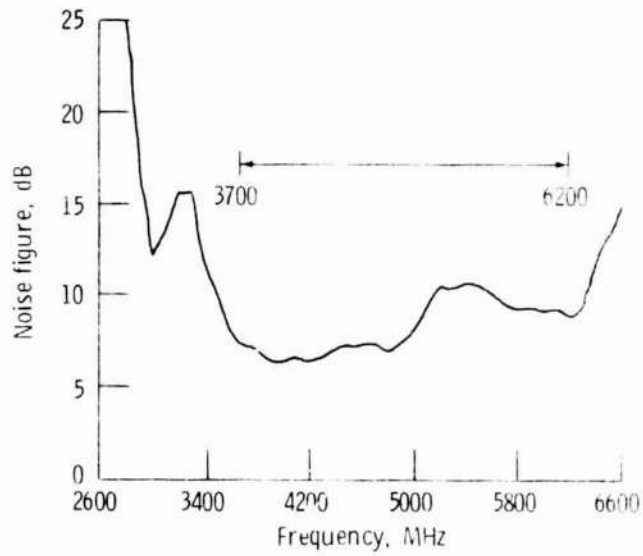

Figure 7. - Noise figure versus intermediate output frequency, LNR receiver 2.

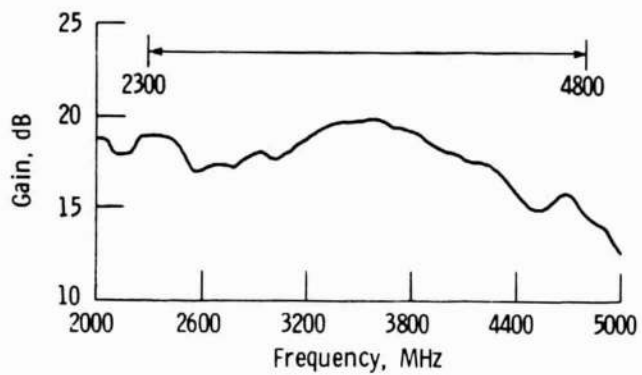

Figure 8. - Gain versus intermediate output frequency, ITT receiver 1.

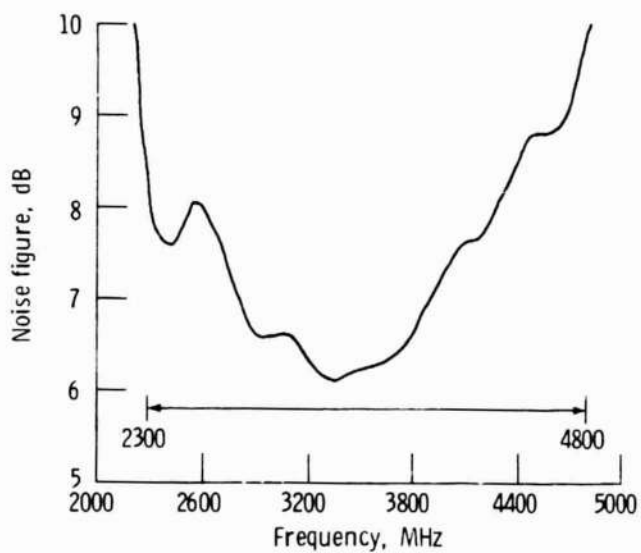

Figure 9. - Noise figure versus intermediate output frequency, ITT receiver 1.

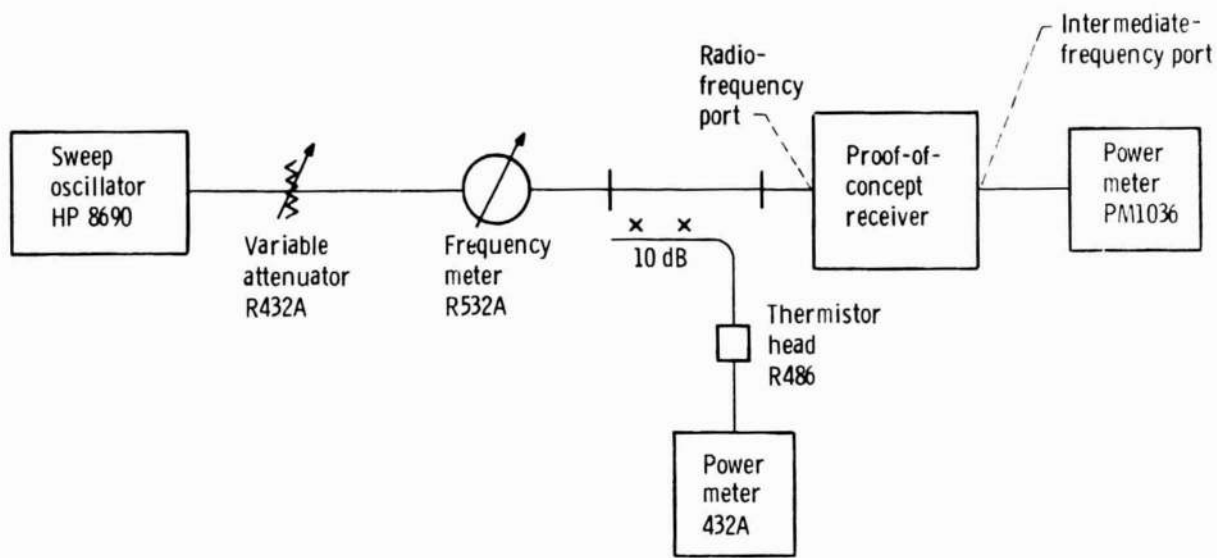

Figure 10. - Block diagram of 1-dB compression point test.

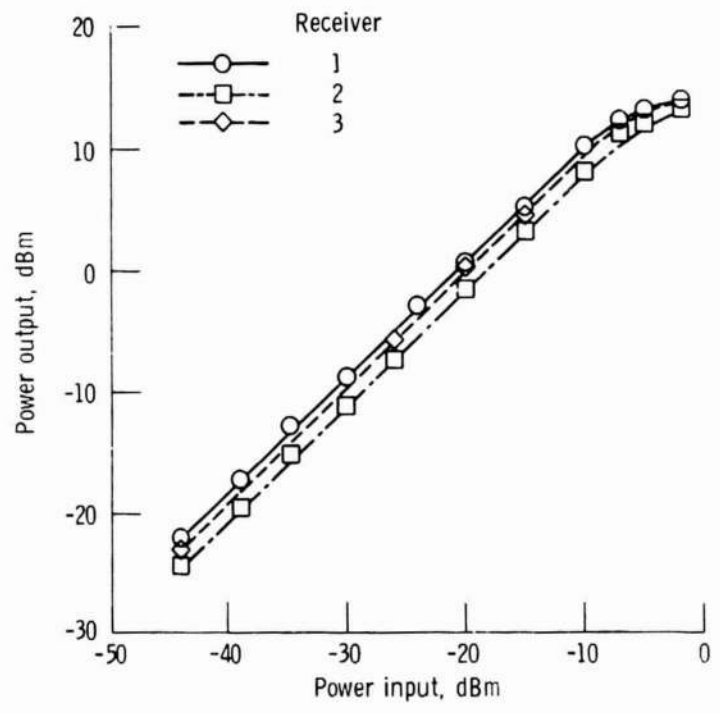

Figure 11. - Power curves for LNR receivers.

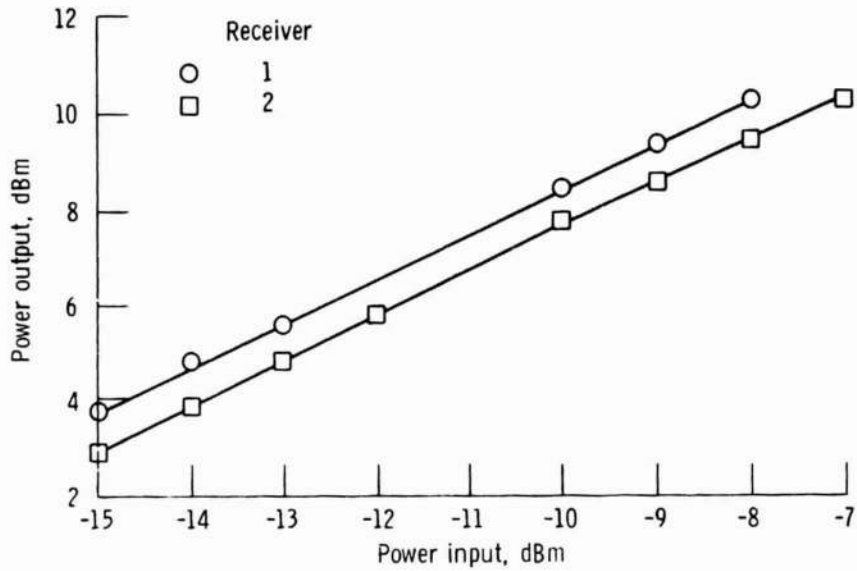

Figure 12. - Power curves for ITT receivers.

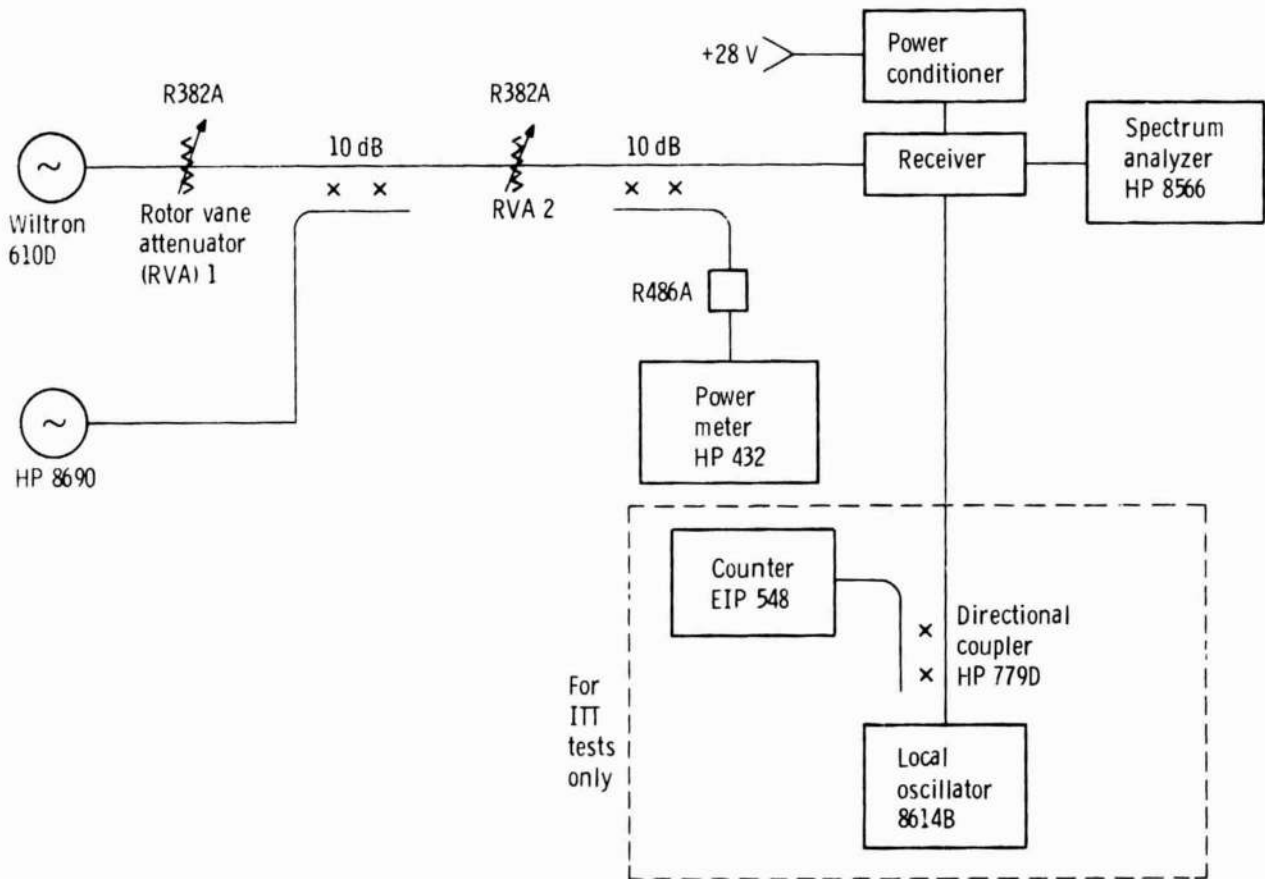
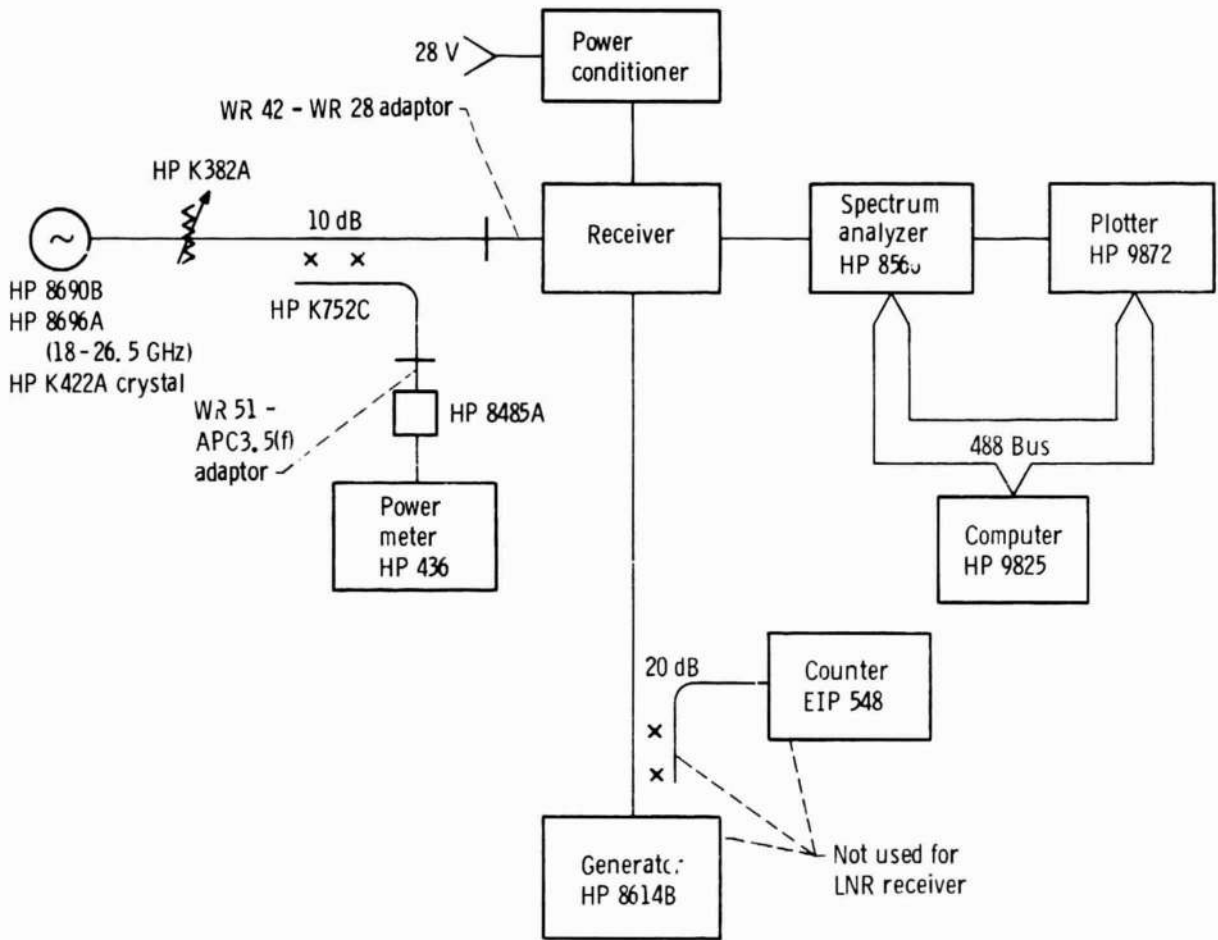

Figure 13. - Block diagram of third-order intermodulation tests, ITT and LNR receivers.



	ITT	LNR
Radiofrequency, GHz	27.5 - 30	27.5 - 30
Local oscillator, GHz	25.2	23.8
Intermediate frequency, GHz	2.3 - 4.8	3.7 - 6.2
Image band, GHz	20.4 - 22.9	17.6 - 20.1
Image specification, dB receiver output	15	15

Figure 14. - Equipment configuration for image response tests.

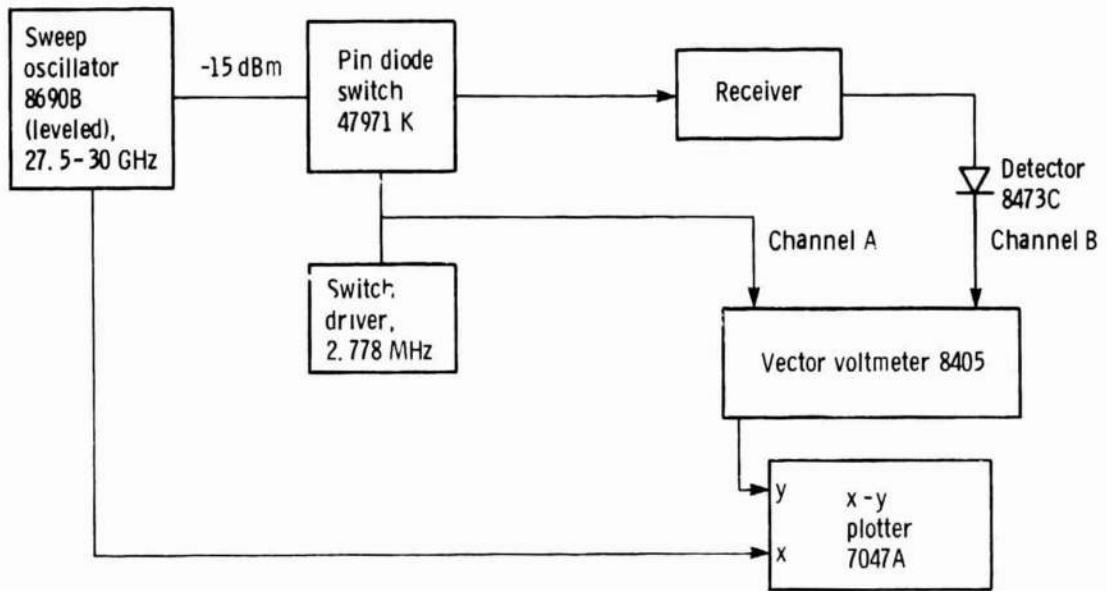

Figure 15. - Block diagram of group delay measurement.

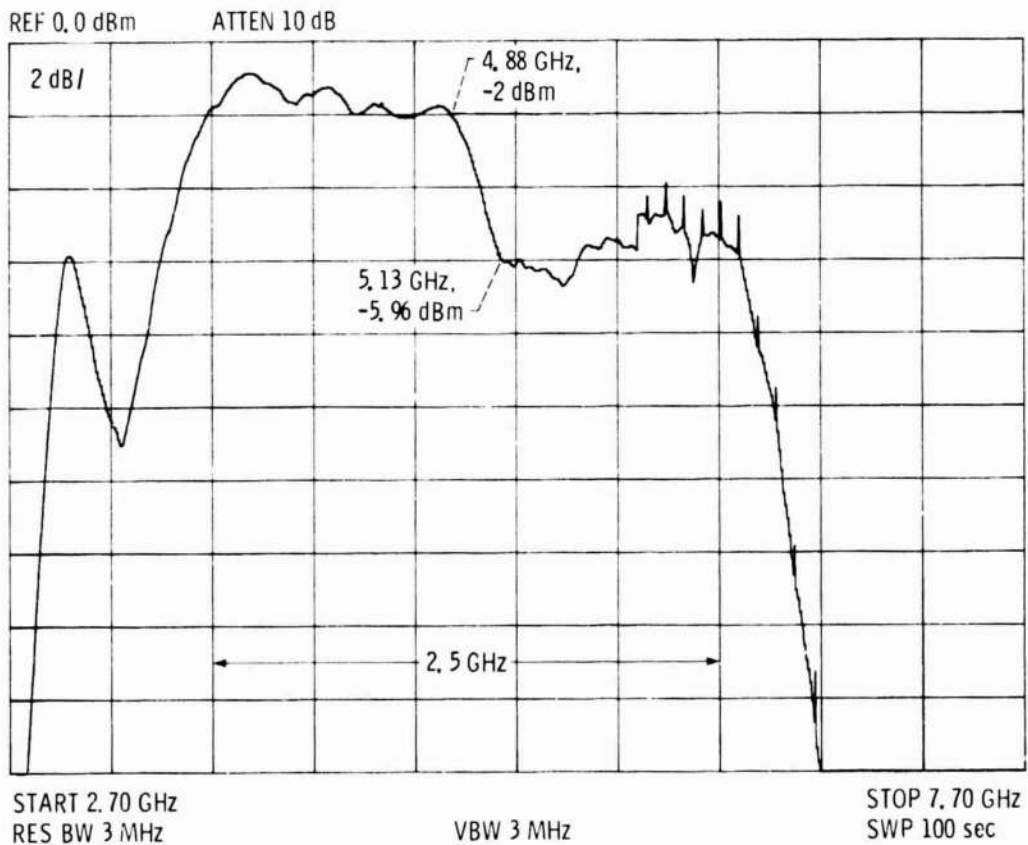

Figure 16. - LNR-2 gain slope test (1/25/83).

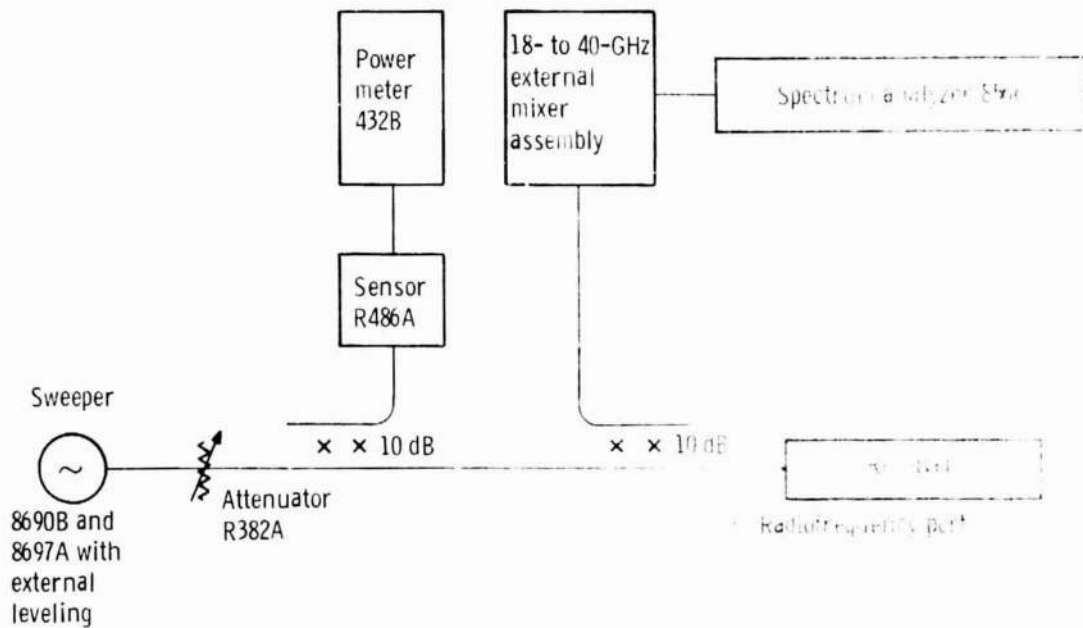

Figure 17. - Block diagram of input voltage standing-wave ratio measurements.

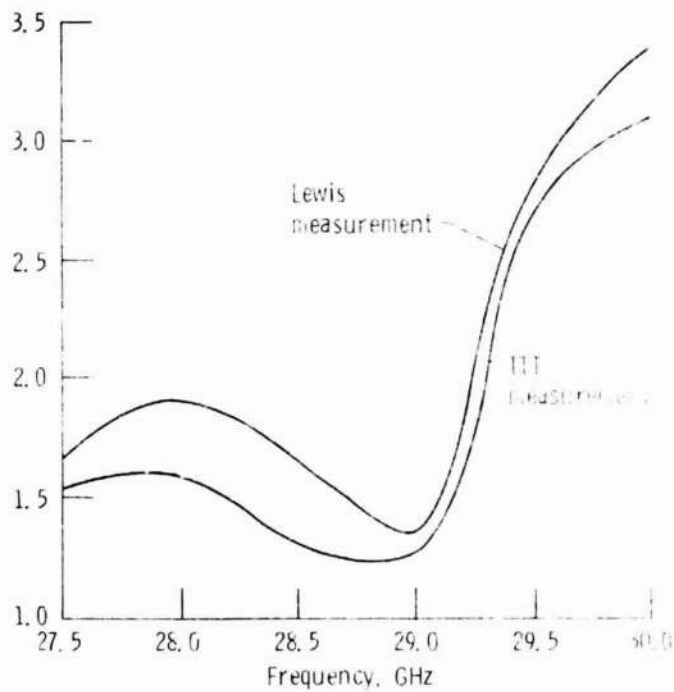

Figure 18. - Input voltage standing-wave ratio versus frequency, ITT receiver 2.

ORIGINAL PAGE IS
OF POOR QUALITY

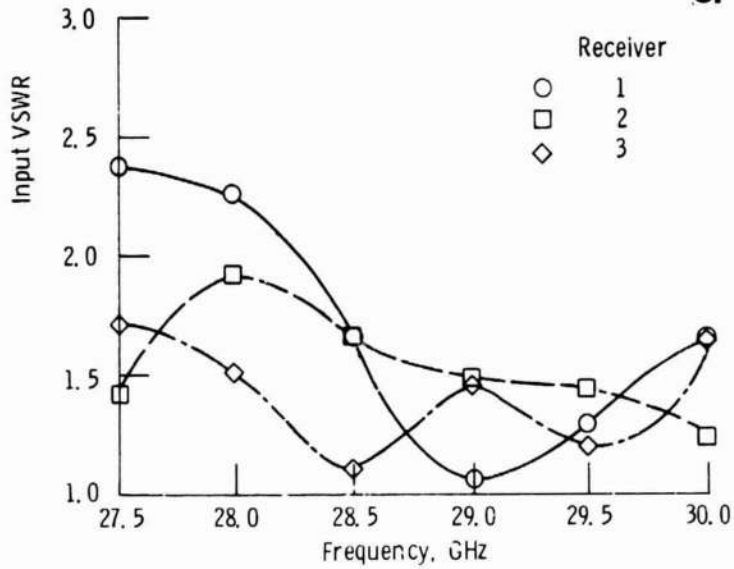

Figure 19. - Voltage standing-wave ratios for LNR receivers.

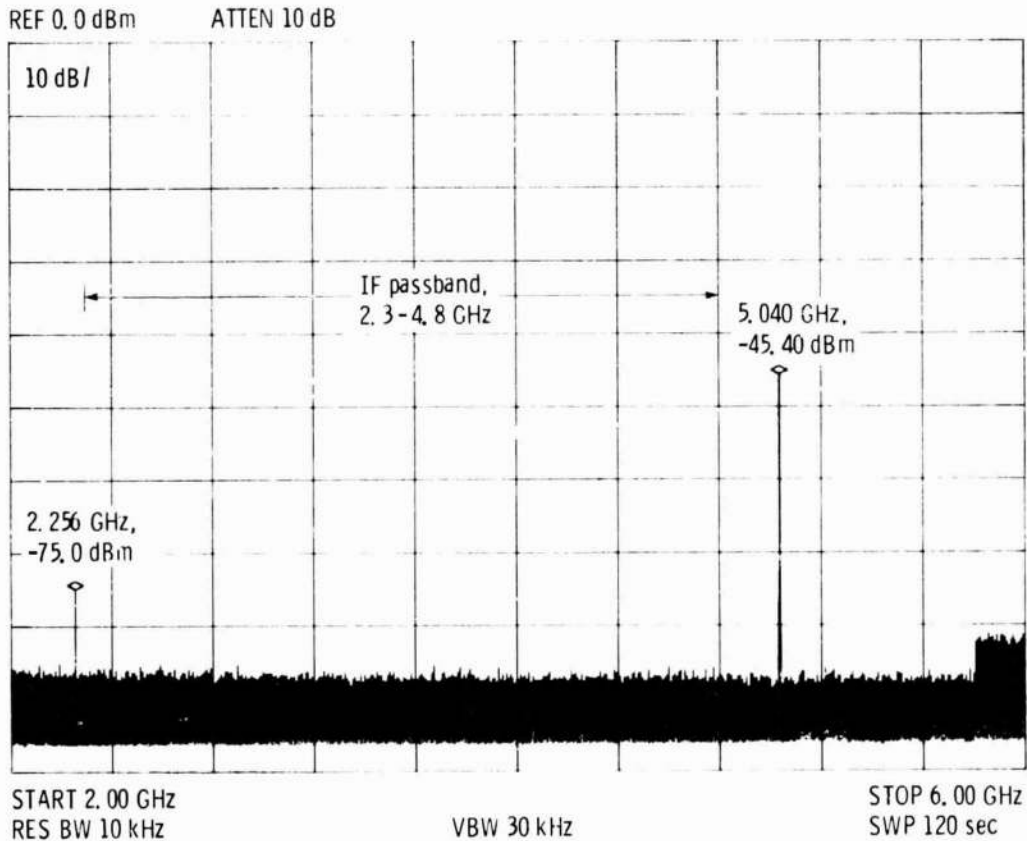
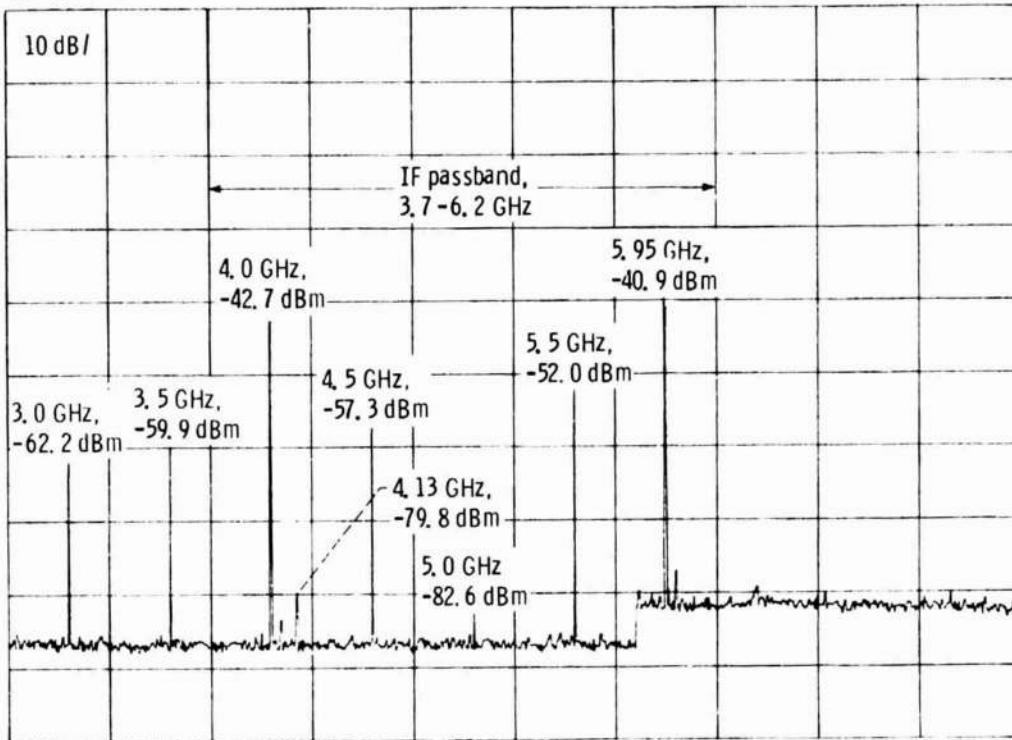

Figure 20. - ITT-1 output spectrum (6/3/83).

REF 0.0 dBm

ATTEN 10 dB



START 2.70 GHz
RES BW 10 kHz

VBW 30 kHz

STOP 7.70 GHz
SWP 151 sec

Figure 21. - LNR-1 output spectrum (7/8/83).

1. Report No. NASA TM-87171		2. Government Accession No.		3. Recipient's Catalog No.	
4. Title and Subtitle Testing of 30-GHz Low Noise Receivers				5. Report Date	
				6. Performing Organization Code 650-60-23	
7. Author(s) Martin J. Conroy and Robert J. Kerczewski				8. Performing Organization Report No. E-2809	
				10. Work Unit No.	
9. Performing Organization Name and Address National Aeronautics and Space Administration Lewis Research Center Cleveland, Ohio 44135				11. Contract or Grant No.	
				13. Type of Report and Period Covered Technical Memorandum	
12. Sponsoring Agency Name and Address National Aeronautics and Space Administration Washington, D.C. 20546				14. Sponsoring Agency Code	
15. Supplementary Notes Prepared for the Eleventh Annual Communication Satellite Systems Conference sponsored by the American Institute of Aeronautics and Astronautics, San Diego, California, March 16-20, 1986. Martin J. Conroy, NASA Lewis Research Center, and Robert J. Kerczewski ANALEX Corporation, Cleveland, Ohio.					
16. Abstract NASA-sponsored studies of the growth in communications traffic have indicated that the frequency spectrum allocated to fixed-service satellites at the C and Ku bands will reach saturation by the early 1990's. The next higher frequency bands allocated for communications satellites are 27.5 to 30 GHz for the uplink and 17.7 to 20.2 GHz for the downlink. Current plans for developing satellite systems that use these bands include a NASA demonstration satellite (ACTS). One of the components identified as critical to the success of that mission is a 27.5 to 30 GHz satellite receiver. In response to that identification, NASA has sponsored the development of such a receiver to the proof-of-concept (POC) level. Design and fabrication of such POC model receivers was carried out under parallel contracts awarded to LNR Communications, Inc. of Hauppauge, New York and to ITT Defense Communications Division of Nutley, New Jersey. The most significant of the performance goals were a 5 dB maximum noise figure, a 2.5 GHz passband, and 20 dB RF to IF gain. Following delivery of hardware from each of the contractors, an in-house test program was undertaken at NASA's Lewis Research Center in order to verify the contractor-reported performance and to provide a comparison of the two receivers under identical test conditions. The present paper reports the results of those tests.					
17. Key Words (Suggested by Author(s)) 30-GHz receivers			18. Distribution Statement Unclassified - unlimited STAR Category 32		
19. Security Classif. (of this report) Unclassified		20. Security Classif. (of this page) Unclassified		21. No. of pages	22. Price*