

Open Research Online

The Open University's repository of research publications and other research outputs

Testing of a large adjustable hydrodynamic journal bearing

Conference or Workshop Item

How to cite:

Martin, Keith and Parkins, David (2001). Testing of a large adjustable hydrodynamic journal bearing. In: ASME/STLE International Joint Tribology Conference, 21-24 Oct 2001, San Francisco.

For guidance on citations see [FAQs](#).

© 2001 The Authors

Version: Accepted Manuscript

Link(s) to article on publisher's website:
<http://dx.doi.org/doi:10.1080/10402000108982495>

Copyright and Moral Rights for the articles on this site are retained by the individual authors and/or other copyright owners. For more information on Open Research Online's [data policy](#) on reuse of materials please consult the policies page.

oro.open.ac.uk

TESTING OF A LARGE ADJUSTABLE HYDRODYNAMIC JOURNAL BEARING

James Keith Martin, Member STLE
Head of Lubrication Research Group
Department of Environmental and Mechanical Engineering
The Open University
Milton Keynes
MK7 6AA
UK

Tel: +44 1908 652112 Fax: +44 1908 652192 email: j.k.martin@open.ac.uk

David Walter Parkins, Member STLE
Lubrication Research Group
Department of Environmental and Mechanical Engineering
The Open University
Milton Keynes
MK7 6AA
UK

Tel: +44 1908 654563 Fax: +44 1908 652192 email: d.w.parkins@open.ac.uk

ABSTRACT

The design and testing of two novel adjustable hydrodynamic journal bearings are outlined. Each was designed to replace a conventional bearing in a large marine gearbox. They were tested in a land based rig and their performances compared with that of the conventional bearing.

The novel bearings demonstrated the ability to suppress journal orbits, to reposition the journal centre in any direction, and to operate with significantly reduced temperature rise. One of the bearings also demonstrated the ability to translate the journal centre in a controlled manner by an amount exceeding double the clearance of the conventional bearing. Implications of such characteristics are considered as potential benefits in various bearing applications.

Key words: Adjustable, multi-lobe, hydrodynamic, journal bearing

NOMENCLATURE

C_r	Concentric radial clearance	m
DC_x	Journal orbit, CRO D/C offset	mV
DC_y	Journal orbit, CRO D/C offset	mV
O_x	Journal orbit width, channel x	mm
O_y	Journal orbit width, channel y	mm
P_1	Oil supply inlet pressure	$N \cdot m^{-2}$
Q	Oil supply flow rate	$m^3 \cdot s^{-1}$
R_x	Voltmeter reading, transducer channel x	V
R_y	Voltmeter reading, transducer channel y	V
T_1	Oil exit temperature, pad 1	$^{\circ}C$
T_2	Oil exit temperature, pad 2	$^{\circ}C$
T_3	Oil exit temperature, pad 3	$^{\circ}C$
T_4	Oil exit temperature, pad 4	$^{\circ}C$
T_5	Oil supply inlet temperature	$^{\circ}C$
T_6	Oil exit temperature	$^{\circ}C$
T_7	Current bearing internal temperature	$^{\circ}C$
T_8	Gearbox internal ambient temperature	$^{\circ}C$
T_B	Bearing B internal temperature	$^{\circ}C$
T_C	Bearing C internal temperature	$^{\circ}C$
T_D	Bearing D internal temperature	$^{\circ}C$
x, y, z	Local axes, directions	–
α_x	Calibration constant, transducer-DVM, channel axis x	$V \cdot m^{-1}$

α_y	Calibration constant, transducer-DVM, channel axis y	$V \cdot m^{-1}$
β_x	Calibration constant, transducer-CRO, channel axis x	$V \cdot m^{-1}$
β_y	Calibration constant, transducer-CRO, channel axis y	$V \cdot m^{-1}$
ΔT	Oil temperature rise, overall ($= T_6 - T_5$)	$^{\circ}C$
ω	Shaft rotational speed	s^{-1} , r.p.m.
ϕ	Bearing resultant load angle Δ	$^{\circ}$, rad

INTRODUCTION

Certain UK Royal Navy ships use marinised gas turbine propulsion units. Power is transmitted through a main propulsion machinery set which includes a primary gearing train supported by fluid film bearings. The train is double helical, with one pinion and one wheel. As part of ongoing investigations into gear alignment and noise signatures attention has progressed to the fluid film bearings, in particular those which support the pinion shaft.

A land based test rig includes a main propulsion primary gearing train. The layout is shown in Fig. 1 and the pinion bearings are marked A and B. The wheel bearings are marked C and D. Figure 2 shows the exposed main components, with bearing B in the foreground. The overall construction of the test rig is similar to the ship borne machinery set, and its casing is constructed of welded steel channel and plate, fixed to the concrete floor of the test cell. Transmission loads are provided by an electric motor which applies an input torque directly to the pinion shaft. This torque is reacted by drive train inertia and an AC alternator drive. The alternator is coupled to the main gear output shaft through a speed increasing gearbox and the torque transmitted is set by a series of 3 large external resistors dissipating energy as heat to atmosphere. Motor and pinion shaft speed was set at 1500 r/min.

A co-operative project was set up whereby 2 versions of a novel adjustable bearing were designed, manufactured and tested in turn in the position of bearing A in the test rig. The novel bearings were adjustable in a proactive manner irrespective of the bearing operating conditions. This effects a degree of control in the size and position of rotational orbits, along with other characteristics of potential benefit compared with conventional bearings. The main features have been published by BTG International (1999), who hold patents on the concept (Martin, Parkins, 1995).

The objectives of the project were to demonstrate the bearings' abilities to reposition the journal centre of rotation whilst in operation; to suppress journal orbits for a range of loads, including zero; and to provide reduced oil temperature rises compared to the current bearing arrangement.

NOVEL BEARING DESIGN OUTLINES

The two bearings are shown in Fig. 3, (before finish machining). Both bearings included 4 pads controlled by similar types of adjuster pin. Each pin comprised a tapered shank, location thread and remote connection. Each pin was located parallel to the longitudinal axis of the bearing and provided solid load paths radially between the pads and housing structures. Figure 4 shows one pin arrangement. The thread location controlled the longitudinal displacement of the pin as it turned, imparting the required radial displacement adjustment to the bearing pad, perpendicular to the bearing centre line. The thread location also incorporated means to permit lateral displacement of the pin in the radial direction. Thus for each pad the convergence angle of the hydrodynamic pressure field could be altered, irrespective of the load conditions acting.

Bearing No. 1 on the left of Fig. 3 was a simpler version with each pad controlled by a single pin providing an infinitely variable tilt angle. Each pad was formed within and remained part of the bearing ring. The spring stiffness for adjustment return was by the resilience of the deformable pad. Bearing No.2 on the right of Fig. 3 had two pins for each pad which were separate components. This arrangement provided a further degree of adjustment in a parallel radial mode as well as tilt angle, both being infinitely and independently variable, and which could accommodate reverse rotation. Spring stiffness for adjustment return was provided by retaining springs.

The adjuster systems were designed and installed such that at a selected zero adjustment position the pad inner bore surfaces were concentric with the bearing housing. Final machining of the bores was performed with this set up to give bore diameters as near as possible to that of the current bearing. Actual measured values and resulting clearances are given in Appendix A. It should be noted that the radial clearance for both novel bearing assemblies was infinitely variable between the limits of the pad adjustment ranges.

INSTRUMENTATION

The instrumentation comprised 2 main systems covering the shaft radial displacement and bearing oil temperatures respectively. The shaft displacement was sensed by inductive position transducers, and temperatures by thermocouples. In addition a turbine type flow-meter was incorporated within the bearing oil inlet supply line.

The shaft displacement was sensed by two transducer probes from which a trace signal representing the orbit of the centre of rotation of the journal at position A could be obtained. Output was a D.C. voltage which was fed to an oscilloscope and digital voltmeter.

For bearing position A temperatures were measured by T-type thermocouples. Two were used in turn for comparing overall oil temperature rises for tests with the current and two novel bearings. Others were affixed permanently one each to the novel bearing pads, in the axial centre line position directly on the trailing edge. In this position they could determine for each of the 2 novel bearings the temperature of the exit oil from each hydrodynamic pressure field. K-type thermocouples were also fitted to the conventional bearings A, B, C and D, to within 1mm of and sealed from the oil surfaces.

CALIBRATION PROCEDURES

Position transducers, in situ, shaft displacement

Experience with this type of instrumentation indicated a possible tendency for drift errors over time but with characteristic gradients staying constant. Using dial gauge indicators, allowing for shaft tilt and offset displacements, in situ calibration gradient constants α_x and α_y were obtained for the digital voltmeters in terms of $V \cdot m^{-1}$ for the linear portion of the transducer range likely in use, similarly for the oscilloscope calibration constants β_x and β_y . This calibration exercise was repeated before and after testing each bearing.

Tests involving comparable situations were conducted in complete sessions to minimise any drift effects that may have occurred day to day and no data were taken as reliable until the instrumentation had been live for at least 1 hour.

Bearing pad position and adjustment

For both novel bearings each pad assembly was calibrated to relate the adjuster pin axial displacements to corresponding pad radial displacements and tilt angle. The axial adjustment position for each pin was measured with a depth micrometer, and the radial adjustment displacement of each pad was measured with a dial gauge indicator installed to act radially from the bearing surface. From these data the relationship between pad tilt angle and adjuster

pin turns was derived. Figure 5 shows one resulting adjustment characteristic, for bearing 1. For bearing 2 each pad could be adjusted in both tilt and radial modes.

TESTING

Bearings were tested in one circumferential orientation position only, as it was known from previous work that the adjustable bearing concept was not adversely sensitive to orientation or load direction (Martin, 1997). 4 separate test load conditions could be set giving known loads on Bearing A as depicted in Table 2, Appendix A. Warm up took between 1 and 2 hours, giving sufficient time for the instrumentation systems to stabilise. Temperatures were also stabilised before taking any data.

Parameters recorded were; shaft speed (ω), load setting (L), journal orbit size and offset (O_x , O_y , DC_x , DC_y), position transducer readings (R_x , R_y), temperatures of oil inlet and outlet (T_5 , T_6), temperatures of oil at pad exits (T_1 , T_2 , T_3 , T_4), oil inlet supply pressure and flow rate (P_1 , Q) and various other temperatures (T_7 , T_8 , T_B , T_C , T_D). At various stages repeat tests were carried out to check repeatability, scatter and drift effects.

In summary the tests carried out can be grouped as follows:

- | | |
|-----------------|--|
| Current bearing | – baseline tests to establish performance for a range of loads. |
| Novel bearing 1 | – operation with zero pad adjustments for a range of loads.
– orbit suppression by symmetrical pad adjustments for a range of loads.
– controlled journal centre positioning by asymmetrical pad adjustments at zero and full load. |
| Novel bearing 2 | – operation with zero pad adjustments for a range of loads.
– orbit suppression by symmetrical pad adjustments for a range of loads.
– controlled journal centre positioning by asymmetrical pad adjustments at various loads.
– controlled large lateral journal centre translation by opposing pad adjustments for 2 loads. |

All tests were conducted with the rig warmed up and running at its nominal pinion shaft speed of 1500 r/min. Pad adjustments were carried out in situ during operation. For all bearings, particularly at test conditions giving low net radial loads, journal orbits were produced and maintained at shaft rotational speed. It was believed that these were driven by small variations in radial load due to the gear teeth meshing, possible unbalances in pinion and shaft masses and influences due to the shaft coupling.

Current bearing, baseline tests

Following commissioning trials, calibrations and warm up, the baseline performance was established for the current bearing in position A at the 4 test load conditions.

Novel bearing 1, tests

A similar series of baseline tests was performed with the novel bearing 1 installed at position A and all pad adjustments set at zero.

The adjustment capability was then tested for load condition 1. A series of increasing equal pad tilt angles from 0.078° to 0.208° was set for all 4 pads. This had the effect of suppressing the journal orbit. The test was repeated for load condition 4 and the orbit suppression was maintained.

The effect of asymmetric pad adjustments was tested for load condition 1 and all pads set initially at tilt angle 0.166° , and for load condition 4 with initial tilt angle 0.208° . For both cases each pad was selected singly and its adjustment reset to zero. The effect on journal centre position was noted. The pad was then restored to its original adjustment setting before selecting the next pad and repeating the process.

Novel Bearing 2, tests

A series of baseline tests was performed with the novel bearing 2 installed at position A and all pad adjustments set at zero.

For reference pads and pins were numbered as depicted in Fig. 6. Investigations into orbit suppression were by imparting equal adjustments to each pad's trailing pin (Nos. 2,4,6,8), leaving the leading pins (Nos. 1,3,5,7) set at zero. For test load conditions 1 and 2 equal pad adjustments of tilt angle 0.087° , then 0.174° , were set for all 4 pads. This had the effect of suppressing the journal orbit. Following a break in testing these experiments were repeated with the same result.

The effect of asymmetric adjustments was tested from starting conditions different to those for bearing 1. For load conditions 2 and 4 in turn, pad adjustments were all set first at zero. Then each pad was set singly at tilt angle 0.174° , with all other pads set at zero, and the effect on journal centre position noted. As a further check for repeatability tests for load condition 2 were repeated 2 days later.

A test then demonstrated a large controlled lateral translation of the journal centre, for load conditions 2 and 4 in turn and all 4 pads first set with an equal tilt angle of 0.087° . A controlled lateral translation of orbit centre was then precipitated by applying equal negative adjustments to pins 7 and 8 and equal positive adjustments to pins 4 and 3, to maintain the net tilt settings. The order was 7-8-4-3 to maintain oil film convergence during adjustment. The test was continued until a large translation was sustained following which the initial conditions were restored and baseline repeat tests carried out.

DISCUSSION OF TEST RESULTS

Current bearing, journal orbits

The journal orbit for the current bearing was little affected by load setting. The journal orbit size O_x component varied between 0.047 mm for load condition 4 to 0.041 mm for load condition 1, a 12.8% reduction. Similarly the O_y component reduced from 0.050 to 0.043 mm, or 14%. The repeat tests over 1½ hours later for load condition 4 showed changes in the orbit size for O_x of +6.4% and for O_y of -8.0%. The averages for all recorded values were $O_x = 0.046$, $O_y = 0.048$ mm.

Current bearing, oil temperatures and flow rates

Oil flow rates Q for the current bearing were reasonably constant. Lowest flow rates were for load conditions 2 and 3 rising by 22.5% for load case 4. This increase was reduced to 12.5% for the repeat load condition 4 test 1½ hours later. Temperature rise ΔT was lowest at 7.0 °C for load condition 4, increasing to 12.0 °C for load condition 1. The bearing white metal temperature T_7 , (1 mm radially from the oil film) was lowest at 57 °C for load condition 1 rising to 62.5 °C for load condition 4. The bearing after testing showed no damage other than polishing witness marks at the lower region. These had been evident before testing and were believed to be due to start up skid effects.

Novel bearing 1, journal orbits

With adjuster settings at the zero position the orbit sizes were very similar to those for the current bearing but with greater differences between the O_x and O_y components. The orbit size was slightly lower for load condition 4. These effects were consistent for repeat tests for load conditions 1 and 4 almost 2 hours later. The averages for all recorded values were $O_x = 0.048$, $O_y = 0.039$ mm.

Figure 7 shows the effect on journal orbits of the application of equal adjustments to all pads for load condition 1. A steady reduction in orbit size for increasing adjustment is observed. Between zero to maximum adjustments the orbit size reductions were O_x : 0.05 to 0.023 mm, O_y : 0.043 to 0.024 mm i.e. 54% and 44% respectively. For load condition 4 the orbit size reductions were O_x : 0.04 to 0.026 mm, O_y : 0.034 to 0.021 mm i.e. 35% and 38% respectively.

With full adjustments applied, i.e. a tilt angle of 0.208°, the orbit size remained constant whatever the load setting, including zero. The orbit size increased to the original magnitude when adjuster pins were reset to zero.

Novel bearing 1, asymmetric adjustments

For load condition 1 the journal centre tracked towards the particular pad being adjusted (back to its zero position). The amount varied between about 0.018 mm for pad 1, to about 0.074 mm for pad 2. These were equivalent to approximately 7% and 29% of C_T respectively. For load condition 4 the movements were about 0.016 mm for pad 3 to 0.106 mm to pad 1. These were equivalent to approximately 6% to 41% of C_T respectively. Despite the variation in magnitudes the broad pattern of adjustments could be observed:

- (i) Each translation was directly associated and in line with the pad being adjusted. The journal moved towards the pad whose adjustment was being relaxed.
- (ii) A 4 by 90° pattern of journal positions could be produced implying that an adjustment throughout 360° was possible.
- (iii) The largest journal translation was for the full load case nearest the direction of the applied load. The smallest was for the opposite case. Thus the degree of translation produced by a particular pad adjustment was related to the load direction. A loaded pad produced more translation for a given pin adjustment than an unloaded one.

Novel bearing 1, oil temperatures and flow rates

Oil flow rates Q were significantly larger than for the current bearing. They also varied with load setting, being lowest for load condition 1 and highest for load condition 4. For condition 1, flow rates were approximately 40% higher than for the current bearing and for condition 4 between about 60% and 100% higher. There was some variation during tests for nominally identical conditions associated directly with oil inlet temperature T_5 , the higher T_5 the higher Q . No means of flow control was incorporated so the oil supply flow rate was not optimised for the bearing. The increase in flow rate clearly indicated that the bearing presented less restriction than the current bearing, which, combined with reduced temperature rise, gives scope for such flow optimisation.

Temperature rise ΔT was significantly lower than for the current bearing tests and much less variable, irrespective of whether or not adjustments were in play. The values ranged between 4.0 and 7.0 °C for all tests despite greater variation in oil inlet temperature T_5 (which varied from 36.0 to 56.0 °C). Thus for similar test conditions the novel bearing 1 showed reductions in ΔT of between 14 and 25% for load condition 4, and 42% for load condition 1 (the worst case for the current bearing). It was also noted that ΔT decreased slightly as the adjustments came into operation for both load conditions 1 and 4. The lowest value of ΔT was for load condition 4 and full pad adjustments (0.208°), which at 4.0 °C was half that of the current bearing for the same load. The value for load condition 4 and zero adjustments was 6.0 °C.

Thermocouple for pad no. 1 was unserviceable in testing so no data for T_1 were taken.

Otherwise the highest pad temperature recorded was 64 °C for pad 4 (i.e. T_4) which occurred for load conditions 3 and 4, with full pad adjustments (0.208°), and for pad 2 for load conditions 2 and 4, also with full pad adjustments. The highest spread of pad temperatures for a given test occurred for load condition 1 and zero pad adjustments in which case $T_2 = 46.0$ °C and $T_3 = 53.0$ °C. For most tests the spread was 2 or 3 degrees.

Novel bearing 2, journal orbits

With pads at the zero tilt position the orbit sizes showed a large degree of variation depending on the loading condition. At load conditions 3 and 4 the orbits were similar to each other and to those of the current bearing for the same loads, a little larger than those of the novel bearing 1. For load conditions 1 and 2 the orbits were larger (about 50% to 60% C_r) with the load condition 2 showing the largest. Bearing 2 offered a proportionately very large range of pad adjustment with the zero position being at some mid range position. It was consequently more difficult to establish the precise zero position for the pads thus possibly providing a radial clearance that was unintentionally too large on occasion. This could have increased the sensitivity to zero load effects as well as generating larger orbits in unsuppressed test settings. Both effects were observed in repeat tests and highlighted the requirement for a more positive zero position location for this design.

Orbit reductions were in terms of magnitude similar to those achieved by novel bearing 1, the final orbit sizes for all cases being very similar to one another, and representing reductions from the current bearing orbits of on average 50% within limits of $\pm 4\%$. As with the novel bearing 1 the orbit when fully suppressed stayed constant irrespective of load case, including zero. Figure 8 shows typical orbit reductions achievable, in this case for load condition 2.

Novel bearing 2, asymmetric adjustments

Figure 6 shows the effect on the journal centre position whilst each pad was adjusted in turn, for load condition 2, and shows a repeat test after 2 days for the same conditions. For this case the journal centre tracked away from the particular pad being adjusted from its zero position. The amount was approximately equal in all 4 directions of between 0.04 and 0.06 mm, equivalent to 16% to 23% C_r . For load condition 4 the movements were about 0.02 mm for pad 3 to 0.218 mm for pad 1, or 8% to 85% C_r respectively. The broad pattern of adjustments could be observed:

- (i) Each adjustment was directly associated and in line with the pad being adjusted. The journal moved away from the pad whose adjustment was being increased.
- (ii) A 4 by 90° pattern of journal positions could be produced implying that an adjustment throughout 360° was possible.
- (iii) The largest journal translation was for load condition 4 opposite the direction of applied load. The smallest was for load condition 4 in line with the direction of applied load. Thus the degree of translation produced by a particular pad adjustment was related to the load direction. A loaded pad provided more journal centre translation for a given pin adjustment than an unloaded one. It should be noted that for novel bearing 1, motions were achieved by releasing pads from an adjusted position to zero, whilst for novel bearing 2 the converse was the case - motions were achieved by adding pad adjustment from a zero position.

Novel bearing 2, large lateral adjustments

Figure 9 shows large lateral translations of the journal centre, simply achieved by controlled adjustments of pads 2 and 4. For both load conditions tested the translation was predominantly horizontal and increasing the distance between the centre lines of the pinion and main gear set (chosen to avoid gear interference risk). Tests were stopped only to avoid the possibility of damage due to misalignment effects on bearing B and the shaft to motor coupling, otherwise further translation would have been possible. The actual translations achieved were 0.495 mm for load case 2 and 0.604 mm for load case 4. The pinion shaft

could therefore be moved in operation more than twice the clearance of the current bearing and still operate safely carrying the loads with no ill effects to the bearing and test rig.

Novel bearing 2, oil temperatures and flow rates

Oil flow rates Q were significantly larger than for the current bearing, and were fairly constant between 12.7 and 14.9 $\text{l}\cdot\text{min}^{-1}$, being towards the higher end at higher load conditions. For the lower load settings the flow rates were approximately 195% higher, and for load condition 4, 204% higher, than for the current bearing. The comparisons for the novel bearing 1 were 95% and 57% respectively. There was some relationship between the oil inlet temperature T_5 , the higher T_5 the higher Q . No means were available to optimise flow rates but there appeared to be plenty of scope to do so.

Temperature rise ΔT was significantly low, never more than 4 °C and usually 3 °C or less, irrespective of load conditions, pad adjustments, or inlet temperature T_5 . Thus for similar test conditions the novel bearing 2 showed reduction in ΔT over that for the current bearing of 71% for load condition 4, and 83% for load condition 1 (the worst case for the current bearing). The rises themselves were too small to discern any relationship with pad adjustment settings. Figure 10 shows the main results for all 3 bearings for the 4 load conditions. Factors which beneficially affected temperature rise may have been improved oil ingress and exit for each pad related to the segmented construction. Bearing 2 in particular was designed with an oil supply arrangement that minimised carry over of oil between pads. Evidence for a more efficient oil supply for the novel bearings was given by the higher relative flow rates recorded despite the relatively low supply pressure.

It was noted that individual pad temperatures correlated with pad adjustments. When pad adjustments came into play the pad exit oil temperature rose, particularly for pads 1 and 2 for load condition 4. The highest pad temperatures were for full pad adjustment and load condition 4. These were 77 °C and 75 °C for pads 1 and 2 respectively, and 68 °C and 71 °C for pads 3 and 4 (all with oil inlet temperature of 58 °C). With load condition 1 and still with maximum pad adjustments the 4 pad temperatures T_1 , T_2 , T_3 and T_4 were 72 °C, 77 °C, 69 °C and 69 °C respectively. The spread of pad temperatures was about 12 to 14 °C when load condition 4 was applied, and 5 or 6 °C for load condition 1, irrespective of pad adjustments. Pad oil exit temperatures appeared to offer a secondary means of indicating pad adjustments, and providing a primary means of indicating pad load conditions, being very responsive to changing circumstances. The fact that no oil temperatures exceeded the 70 °C range implied that more pad adjustment capacity was always available.

The temperatures in other bearings in the rig were monitored periodically using the thermocouples already in situ, with no cause for concern.

Potential benefits of adjustable bearing design

The attributes and benefits of the adjustable bearing design have been reported by BTG International (1999). Controlled orbit suppression is indicative of increased stiffness and damping, particularly at low loads and eccentricities. This gives improved stability, reduced vibration and noise etc. The capability of adjusting stiffness and damping in operation could aid the passing through or altering of critical speeds giving less chance of damage due to vibration.

The ability to vary or maintain a given centre of rotation irrespective of loading conditions implies a potential for improved accuracy of location for all operating conditions which could

be of benefit for example in maintaining the precision of alignment of gears or in the accuracy of machine tools. For multiple in line bearings load sharing could be set and maintained without the need for complex assembly methods.

Lower temperature rises could lead to reduced thermal effects in lubricants and the supporting structures. Potential also exists for a degree of flow optimisation and reduction of power absorbed which may be of benefit in large diameter or higher speed bearings in terms of saving energy.

The adjustable bearing could give improved accuracy over current forms of bearing but can still be produced with conventional manufacturing methods and materials.

CONCLUSIONS

Two versions of a novel bearing have been designed, manufactured, fitted and tested in the position of a conventional hydrodynamic journal bearing, and within the same radial space, in a marine gearbox test rig. Baseline tests of the current bearing were also carried out. Examination of all bearings subsequent to testing showed negligible wear or damage.

Both novel bearings demonstrated the ability to reposition the journal centre of rotation whilst in operation, in any direction, for a range of loads with differing initial adjustment conditions (e.g.. full adjustments or zero adjustments).

The size of the journal orbit compared to that of the current bearing could be repeatedly reduced by at least 50% with both novel bearings for any of the test load conditions, including that of zero radial load. Such reductions could be made in seconds whilst the bearings continued in operation.

Both novel bearings produced oil temperature rises which were consistently lower than those for the current bearing for comparable conditions for all tests, due probably to increased oil flow rates at the same supply pressure.

Novel bearing 2 demonstrated the capability to laterally translate the journal centre in a controlled and reversible manner by an amount more than double the radial clearance of the current bearing, and limited only by practical considerations of other components in the test rig. This was achieved at both high and low radial load settings, and the load continued to be supported safely with no ill effects. The journal orbit suppression and low temperature rise were also maintained for this adjustment regime.

For both novel bearings the individual pad oil exit temperature provided a simple and reliable means to monitor the loading conditions on the particular pad.

The characteristics demonstrated indicate a number of potential benefits and improvements available in the design and operation of fluid film bearings, still using conventional manufacturing techniques.

Acknowledgements

The authors gratefully acknowledge the support of the UK Defence Evaluation and Research Agency, the Ships Support Agency, and the Open University.

APPENDIX A – BRIEF ENGINEERING DATA

Table 1: Bearing parameters and dimensions (cold)

Dimension	Current bearing	Novel bearing 1	Novel bearing 2
Shaft speed, r/min	1500	1500	1500
Bearing surface	White metal	White metal	White metal
Overall width, mm	95.0	117.0	117.0
Outer diameter, mm	245.1	245.1	245.1
Inner diameter, mm	190.729	190.710	190.710
Journal diameter, mm	190.195	190.195	190.195
Radial clearance, mm * Zero pad adjustments	0.289	0.257	0.257

Table 2: Loads for pinion bearing A

TEST CONDITIONS	1	2	3	4
Vertical load, N	0	4639.0	9070.0	13668.0
Horizontal load, N	0	1955.0	3822.0	5759.0
Resultant load, N	0	4517.0	9601.0	14885.0
ϕ , deg	0	74.6	74.6	74.6

Oil: mineral oil with extreme pressure and pour depressant additives, for steam turbine gear application. Kinematic viscosity 50 cSt at 50°C, filtered and cooled, supplied at 0.7 bar pressure via 25.4 mm bore dia pipe.

References

- BTG International (1999), "Continuously Adjustable Fluid Film Bearing," Leaflet 136333, BTG International Ltd, London, UK.
- Martin, J.K.
Parkins, D.W.(1995), "Fluid Film Bearings," International (PCT) Patent Application, WO-95/29346.
- Martin, J.K. (1997), "Investigations into an Adjustable Fluid Film Bearing," Ph.D. Thesis, Cranfield University, Cranfield, UK.

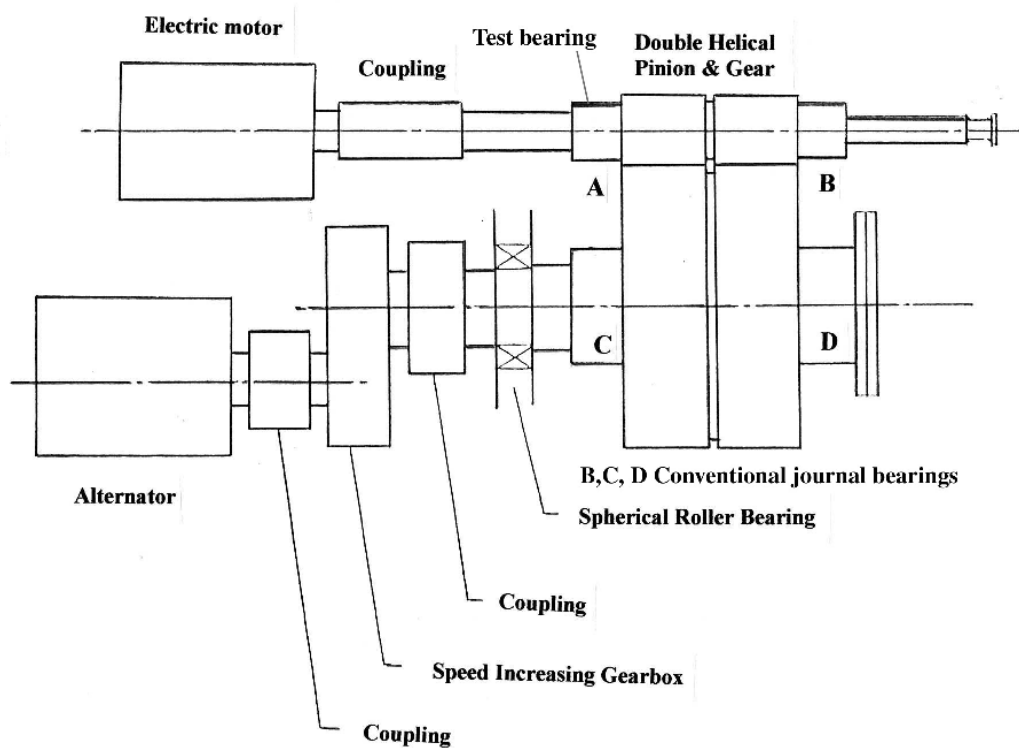

FIG. 1 Test rig layout

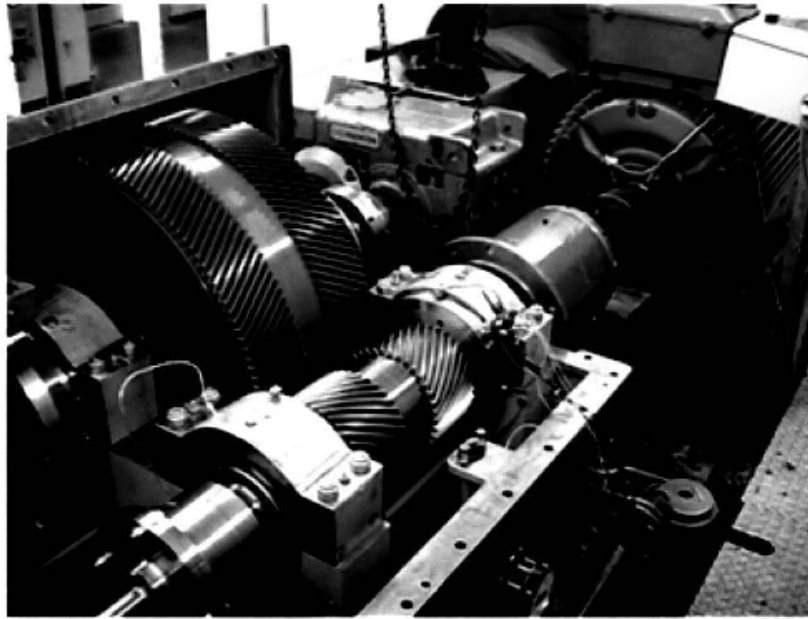

FIG. 2 Exposed gear and pinion set



FIG. 3 Adjustable bearings 1 (left) and 2 (right)

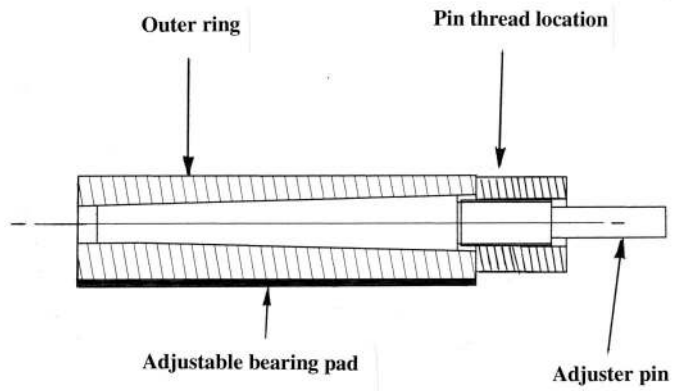

FIG. 4 Adjuster pin arrangement

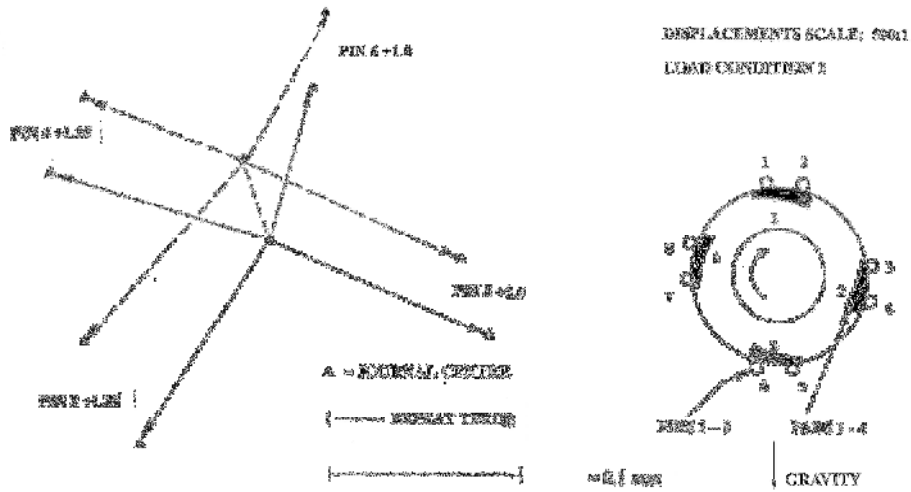
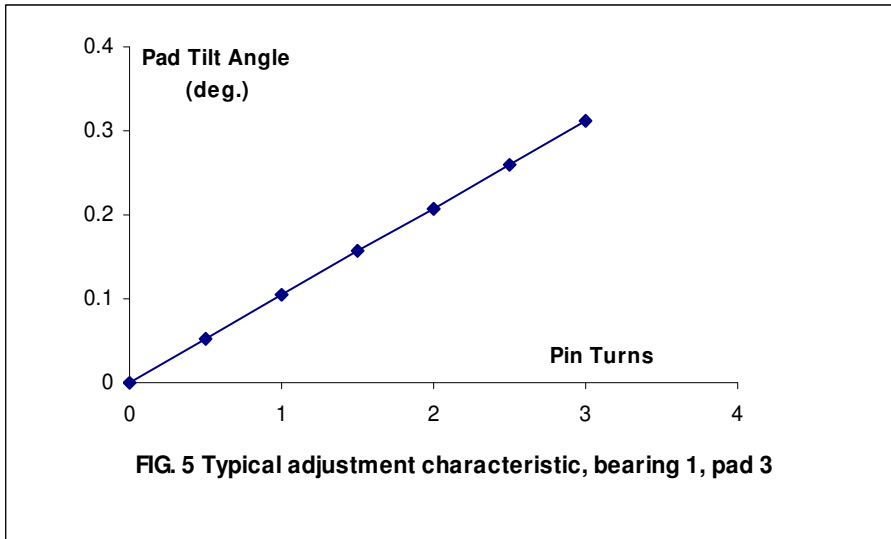
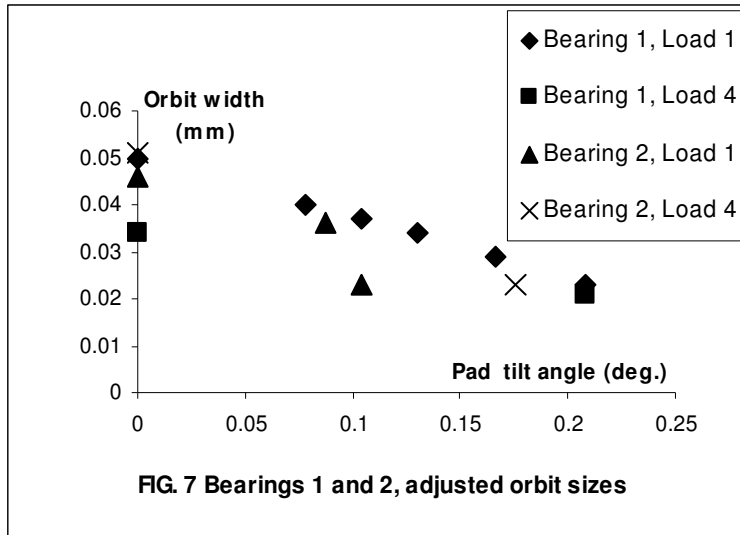

FIG. 6 Bearing 2, repositioning of journal centre



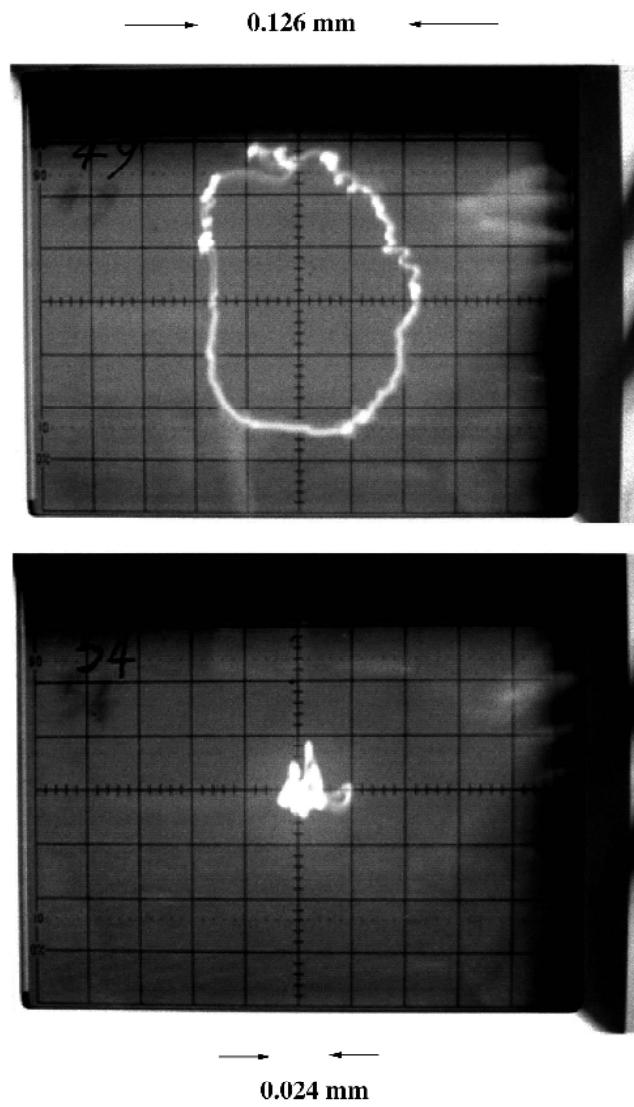

FIG. 8 Bearing 2, orbit suppression, Load condition 2

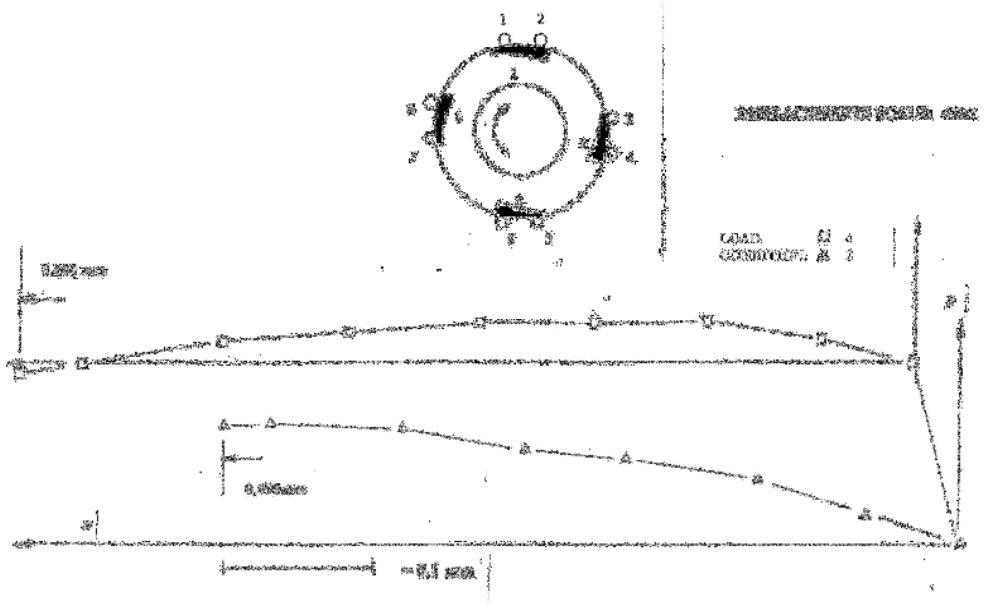

FIG. 9 Bearing 2, large translations of journal centre

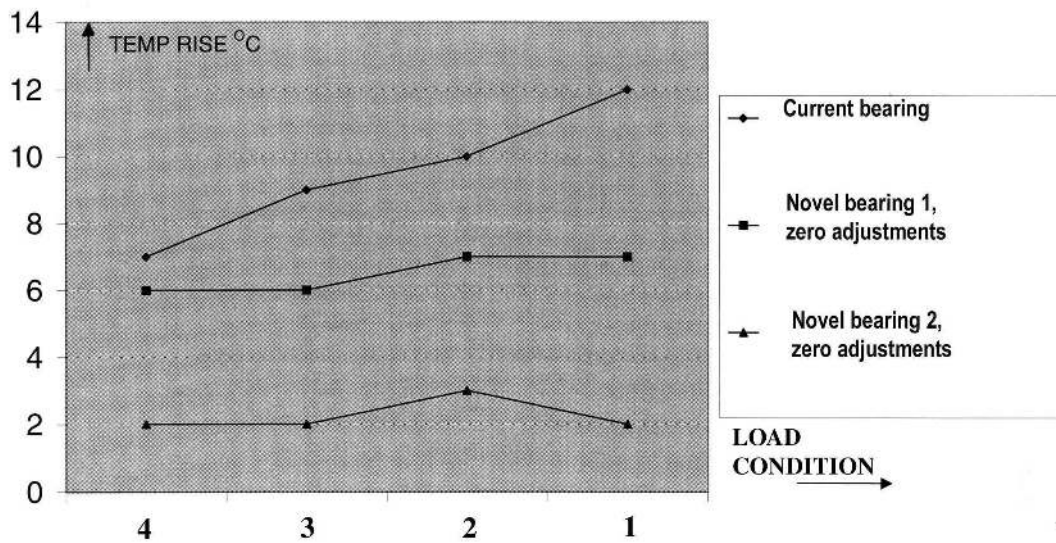

FIG. 10 Temperature rise for all 3 bearings, all load settings

FIG. 1 Test rig layout

FIG. 2 Exposed gear and pinion set

FIG. 3 Adjustable bearings 1 (left) and 2 (right)

FIG. 4 Adjuster pin arrangement

FIG. 5 Typical adjustment characteristic, bearing 1, pad No. 3

FIG. 6 Bearing 2, repositioning of journal centre

FIG. 7 Bearings 1 and 2, adjusted orbit sizes

FIG. 8 Bearing 2, orbit suppression, load condition 2

FIG. 9 Bearing 2, large adjusted translations of journal centre

FIG. 10 Temperature rises for all 3 bearings, all load settings