



**AALBORG UNIVERSITY**  
DENMARK

**Aalborg Universitet**

## **Testing of Low-Power Wide-Area Technologies in Controlled Propagation Environments**

Rodriguez Larrad, Ignacio; Lauridsen, Mads; Arvidsson, Klas; Kvarnstrand, John; Andersson, Mats; Mogensen, Preben Elgaard

*Published in:*  
Loughborough Antenna and Propagation Conference 2017

*DOI (link to publication from Publisher):*  
[10.1049/cp.2017.0271](https://doi.org/10.1049/cp.2017.0271)

*Publication date:*  
2017

*Document Version*  
Accepted author manuscript, peer reviewed version

[Link to publication from Aalborg University](#)

*Citation for published version (APA):*  
Rodriguez Larrad, I., Lauridsen, M., Arvidsson, K., Kvarnstrand, J., Andersson, M., & Mogensen, P. E. (2017). Testing of Low-Power Wide-Area Technologies in Controlled Propagation Environments. In *Loughborough Antenna and Propagation Conference 2017* <https://doi.org/10.1049/cp.2017.0271>

### **General rights**

Copyright and moral rights for the publications made accessible in the public portal are retained by the authors and/or other copyright owners and it is a condition of accessing publications that users recognise and abide by the legal requirements associated with these rights.

- Users may download and print one copy of any publication from the public portal for the purpose of private study or research.
- You may not further distribute the material or use it for any profit-making activity or commercial gain
- You may freely distribute the URL identifying the publication in the public portal -

### **Take down policy**

If you believe that this document breaches copyright please contact us at [vbn@aub.aau.dk](mailto:vbn@aub.aau.dk) providing details, and we will remove access to the work immediately and investigate your claim.

# Testing of Low-Power Wide-Area Technologies in Controlled Propagation Environments

*Ignacio Rodriguez<sup>1</sup>, Mads Lauridsen<sup>1</sup>, Klas Arvidsson<sup>2</sup>, John Kvarnstrand<sup>2</sup>, Mats Andersson<sup>2</sup>, and Preben Mogensen<sup>1</sup>*

<sup>1</sup>Department of Electronic Systems, Aalborg University, Denmark. Email: {irl, ml, pm}@es.aau.dk

<sup>2</sup>Bluetest AB, Sweden. Email: {klas.arvidsson, john.kvarnstrand, mats.r.andersson}@bluetest.se

**Keywords:** IoT, LPWAN, Sigfox, LoRa, OTA testing, Reverberation chamber.

## Abstract

In this study, the uplink performance of Sigfox and LoRa is evaluated in a controlled propagation environment (reverberation chamber). This evaluation is performed in terms of transfer error rate as a function of calibrated path loss, which allows a direct comparison of the performance of both systems under statistically similar propagation conditions. The analysis of the results shows that the proposed setup and testing methodology can be useful for comparing the many new wireless IoT technologies in a practical setting.

## 1 Introduction

Sigfox and LoRa are two of the main low-power wide-area network (LPWAN) technologies competing for the growing wireless Internet of Things (IoT) market. These technologies aim at complementing the traditional cellular systems by providing connectivity to a massive number of low data rate, low power, and low cost devices distributed over large geographical areas using the sub-GHz license-free industrial, scientific, and medical (ISM) bands [1]. Currently, LPWANs based on these technologies are being deployed around the globe to serve a multitude of different use cases; including smart cities, smart grids, smart homes, etc. [1, 2]. From a pure RF perspective, Sigfox and LoRa are very different. While Sigfox utilizes an ultra-narrowband 100 Hz signal and binary phase shift keying (BPSK) modulation to access the radio spectrum, LoRa applies 125-500 kHz chirp spread spectrum (CSS) modulation together with adaptable coding rates. Despite of the differences in nature, the maximum link budget and performance advertised by the Sigfox and LoRa vendors are quite similar, and thus it may not be clear which technology to apply for a given use case.

In order to shed some light over this issue, in recent years, there have been a number of studies exploring coverage on both Sigfox [2, 3] and LoRa [4, 5] practical deployments. These studies analyze very specific scenarios and provide a general idea

of the performance of the systems. However, as pointed out in [1, 5], there is a lack of studies which compare the two LPWAN technologies under the same experimental conditions. One of the few exceptions to this, is [6], where the Sigfox and LoRa coverage is estimated for the same scenario, but with the disadvantage of being a simulation-based study.

The main contribution of this paper is to complement the previous literature, by empirically investigating the uplink (UL) performance of Sigfox and LoRa in the 868 MHz ISM band under similar propagation conditions. This type of measurement study is a challenging task in real-world scenarios due to the collection of data being hampered by the lack of continuous transmissions, the long over-the-air times, and the duty cycle restrictions prescribed by the regulations in the sub-GHz ISM bands; as well as due to the uncontrolled interference that other technologies may generate. Therefore, the investigations are performed inside a reverberation chamber which ensures controlled measurements in an interference-free environment. We specifically study the uplink transfer error rate as a function of calibrated path loss and relate these parameters to the received signal strength indicator (RSSI) and signal-to-noise ratio (SNR) values reported in the Sigfox and LoRa back-ends.

The remainder of the paper is organized as follows: Section 2 details the test setup and how the test is performed. Section 3 presents and discusses the results of the performance test and, finally Section 4 concludes the paper.

## 2 Test Setup and Methodology

The over-the-air (OTA) test setup used in the measurements is depicted in Fig. 1. It is composed of a Bluetest RTS65 reverberation chamber, a variable step attenuator, and the Sigfox and LoRa end devices and base stations connected to their respective back-end servers. The setup includes a signal analyzer connected to the output of the step attenuator for calibration purposes.

The end devices used in the test are Arduino UNO-based. In the case of Sigfox, a TD Next TD1208 transceiver is mounted on the Arduino module. For LoRa, the transceiver used is a Microchip RN2483. In both cases, a customized control software is loaded in the Arduino module to allow remote control

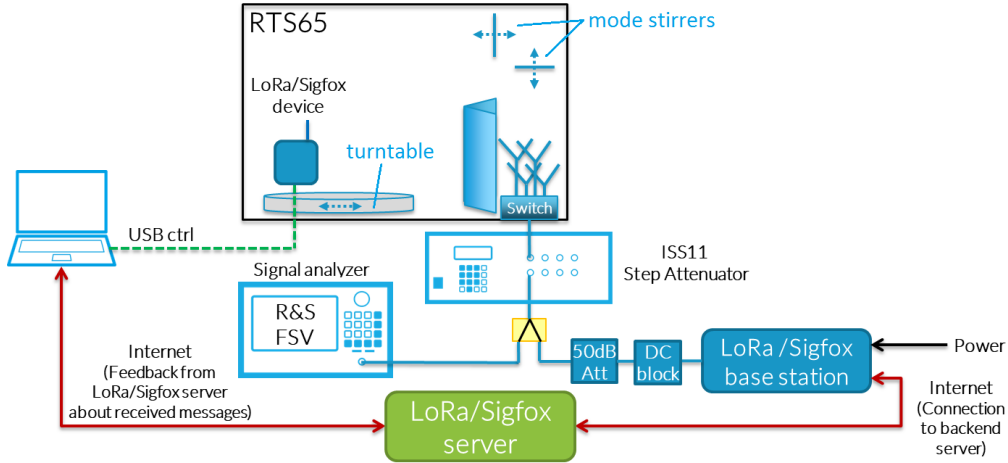

**Fig. 1:** Overview of the OTA test setup.

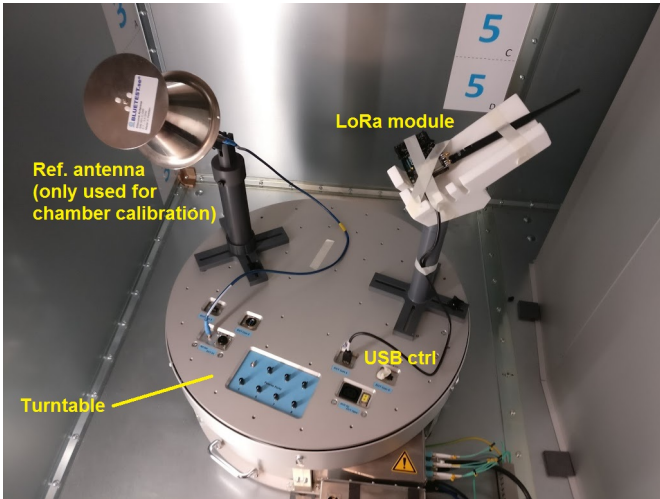

**Fig. 2:** LoRa module mounted on the turntable inside of the reverberation chamber.

via USB from a customized MATLAB software installed in an external control laptop. With respect to the base station side, two commercial devices are used: a Sigfox mini-base-station and a Kerlink LoRa station. The base stations are connected to the internet and forward the received data to their respective cloud back-end servers (the Sigfox back-end service<sup>1</sup> is used for Sigfox, while the Semtech IoT service<sup>2</sup> is used for LoRa). The same laptop used for end device control is connected to the internet to allow having a closed-loop test control. A customized MATLAB routine retrieves the relevant information related to the performed tests from the corresponding back-end servers.

The UL communication link is evaluated under the specific multipath conditions created inside of the chamber [7]. For this particular test, the chamber was not loaded with any absorber, so the resulting channel had low coherence bandwidth (but still fairly large as compared to the test signals) ensuring that both

the Sigfox and LoRa systems experience flat fading with high probability. The end devices are placed on a rotating turntable, as shown in Fig. 2. The movement of the turntable together with the two mode stirrer plates induce a few Hz of Doppler effect to the test. Due to the inherent characteristics of this type of multipath test, the radio channel inside of the chamber merges the effects of the radiation patterns of the antennas at the end device and base station sides with the OTA propagation effects themselves. In this test, the end devices' antennas are standard half-wavelength dipoles, while the commercial receive antennas of both Sigfox and LoRa systems are substituted by the in-built array of the chamber. The resulting signal amplitude and corresponding path loss distributions inside of the chamber follow a Rayleigh distribution. This distribution is highly stable, leading to a high measurement accuracy with a standard deviation lower than 0.3 dB [8]. The average path loss in the chamber ( $L_{\text{chamber}}$ ) is calibrated using a reference antenna and a vector network analyzer. The total path loss between the device and the base station consist of the chamber path loss combined with the external losses including the tunable step attenuator ( $L_{\text{att}}$ ). The end-to-end calibrated average path loss (cPL) level is thus given by:

$$\text{cPL} = L_{\text{chamber}} + L_{\text{att}} \quad [\text{dB}], \quad (1)$$

Based on the described setup and configuration, the performance test routine is the following:

1. Perform chamber setup and calibration - determine the calibrated chamber loss ( $L_{\text{chamber}}$ ).
2. Connect the Sigfox/LoRa base station to the output of the step attenuator (Fig. 1).
3. Install the Sigfox/LoRa end device/module on the turntable inside of the chamber (Fig. 2).
4. Close the chamber and begin mode stirring.
5. Set  $L_{\text{att}}$  to its initial value, which fixes the initial cPL value.
6. Execute performance test: trigger 100 UL transmissions from the end device.

<sup>1</sup> Sigfox back-end service: <https://backend.sigfox.com/>

<sup>2</sup> LoRa back-end service: <http://iot.semtech.com/>

7. Collect test results: retrieve back-end data (RSSI and SNR of the successful transmissions).
8. Set  $L_{\text{att}}$  to the next value and repeat steps 6, 7 and 8 until all the desired cPL values have been swept.
9. Stop mode stirring, open the chamber, and dismount the end device and the base station.

As the reverberation chamber is an isolated environment, there is no risk of interfering with the real-world while testing. The software run on the end devices was modified to override the duty cycle limitations, reducing the minimum waiting time between transmissions, thus speeding up the overall test duration. For each particular test at a particular  $L_{\text{att}}$ /cPL value, a customized payload and sequence number is transmitted, which allows to find the specific results of the test by querying later the back-end server with the appropriate parameters.

The performance of the two systems is evaluated in terms of UL transfer error rate (TER), by accounting for the number of unsuccessful receptions at each of the different tests. Since the payload and sequence numbers for a particular test are known, it is possible to deduct how many transmissions were missed from the successfully received transmissions in the back-end server. In the case of Sigfox, as 3 repetitions are sent per transmission, a secondary metric, repetition error rate (RER), is similarly defined. The number of UL transmissions per test was fixed to 100, as the stability of the distributions of received samples was verified by means of a repeatability test. The maximum variations observed in this test were  $\pm 1\%$  in TER,  $\pm 2.6\%$  in RER,  $\pm 0.1$  dBm in RSSI, and  $\pm 0.1$  dB in SNR.

The TER and RER performance results are presented in the following section in terms of cPL. The analysis is complemented by presenting the performance results in terms of the values received in the back-end server. Two different path loss definitions are given. The first one, RSSI-based path loss (rPL) is defined as follows:

$$\text{rPL} = P_{\text{tx}} - \text{RSSI}_{\text{avg}} \quad [\text{dB}], \quad (2)$$

where  $P_{\text{tx}}$  is the transmit power and  $\text{RSSI}_{\text{avg}}$  is the average value of the RSSI samples logged in the back-end for a particular test. Following a similar approach, the second one is the SNR-based path loss (sPL):

$$\text{sPL} = P_{\text{tx}} - (-174 + 10 \cdot \log_{10}(\text{BW}_r) + \text{SNR}_{\text{avg}}) \quad [\text{dB}], \quad (3)$$

where  $\text{BW}_r$  is the base station receiver bandwidth used for estimating the associated noise floor, and  $\text{SNR}_{\text{avg}}$  is the average value of the SNR samples logged in the back-end for a particular test.

Table 1 summarizes the calibration values, as well as the Sigfox and LoRa test configuration values. Both technologies were set to its maximum payload size (within a single transmission) and, as the objective of the test is to estimate the maximum link budget, both technologies are configured to their maximum protection level (spreading factor 12 and coding rate 4/8 in the case of LoRa).

Parameter	Sigfox	LoRa
Max. Doppler shift	<2 Hz	
Coherence bandwidth	1-3 MHz	
$L_{\text{chamber}}$	36.5 dB	
Frequency band	868.0-868.6 MHz ISM	
Payload	12 bytes	51 bytes
Modulation	BPSK	CSS
Spreading factor	-	12
Coding rate	-	4/8
Signal bandwidth	100 Hz	125 kHz
$P_{\text{tx}}$	16.5 dBm	14.0 dBm
$L_{\text{att}}$	78.6-110.8 dB	88.7-118.8 dB

**Table 1:** Summary of the OTA performance test settings.

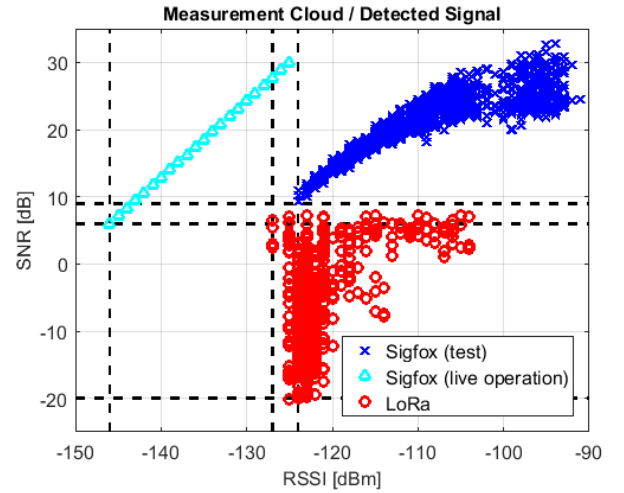

**Fig. 3:** Overview of the full cloud of measurement results.

Technology	RSSI	SNR
Sigfox (test)	-124 dBm	+9 dB
Sigfox (live operation)	-146 dBm	+6 dB
LoRa	-127 dBm	-20 dB

**Table 2:** Minimum detected RSSI and SNR values.

### 3 Results and Discussion

Fig. 3 illustrates the overall measurement results. The color clouds display the different combinations of RSSI and SNR reported at the back-ends. From these clouds of points it can be clearly observed the different RF nature of both technologies: while Sigfox is ultra-narrowband and needs a certain SNR to operate, the spread spectrum nature of LoRa with increased bandwidth makes it more robust to noise, and can operate even in the negative regime of the SNR. The minimum values for each of the technologies, which are valuable information for future studies, are gathered together in Table 2. It should be noted that Sigfox has been tested in different conditions as compared to those recommended for real deployments (i.e. without low-noise amplifier, band-pass cavity filter, ...) which limits the performance measured in this test. As a reference of Sigfox live operation, our own measurement results (from previous campaigns) have been included in both the figure and

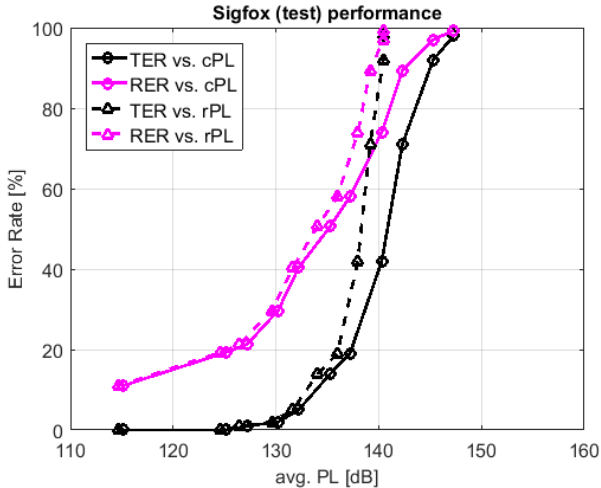

Fig. 4: Sigfox performance results.

the table. These results were obtained by performing multiple drive test-like measurements in the live Danish Sigfox network, exploring both urban (Aalborg) and suburban (Region Nordjylland) scenarios. In parallel with these, also LoRa live operation measurements were performed, observing no significant differences with respect to those reported in the test.

Fig. 4 displays the performance test results for Sigfox. The results are given in terms of TER and RER for different values of cPL and rPL. As it can be seen, the RER is always higher than or equal to the TER. This is due to the fact that a transmission is successful simply by getting at least one of the three repetitions correctly received. The trends observed with both cPL and rPL are the same: the error rate increases with path loss. However, it can be observed how the curves, that are overlapping until a certain level (approximately 135 dB), diverge after that. The lower rPL is due to the truncation of the received RSSI distribution caused by the closeness to the sensitivity level of the base station (see Appendix for details).

In the case of LoRa, the performance test results are given in terms of TER per cPL, rPL and, also sPL in Fig. 5. In this case, the trend observed with rPL is not very representative. Due to the nature of the LoRa technology, at high path loss values, the average RSSI is dominated by noise power and thus, sPL is a better option. The trends observed with cPL and sPL are similar. Once again, there is an issue with the distribution of received SNR so the curves diverge for the higher path loss values. The  $BW_r$  value used in the computation of sPL is empirically fit to 250 kHz (which is twice the bandwidth of the transmitted LoRa signal, and half the maximum LoRa bandwidth possible).

In all cases, the measurement test results are consistent with the expected trends, which provides validation to the methodology used. Under the particular setups considered, a maximum cPL of approximately 147 and 155 dB was observed for the tested Sigfox and LoRa systems, respectively. Once again, it should be noted that the Sigfox performance has been evaluated in this test under limited setup conditions. In case a live operation

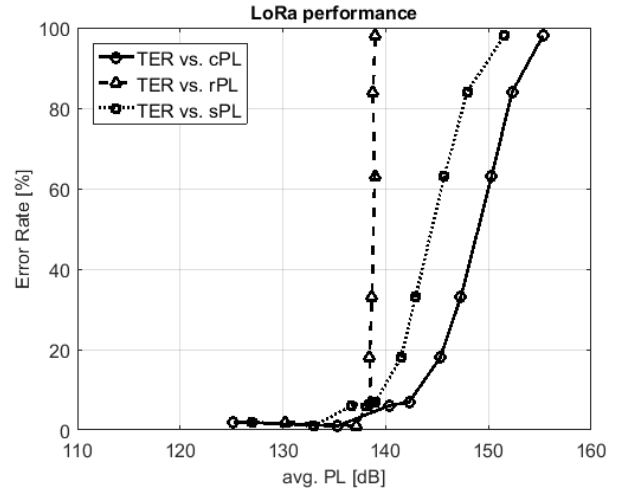

Fig. 5: LoRa performance results.

setup would have been used, we conjecture that a maximum cPL of approximately 165 dB would have been achieved. It should be remarked as well, that the performance test has been done in an interference-free scenario, which allows a fair initial comparison between the different technologies under similar propagation conditions. However, this performance might be degraded in live operation due to the increasing levels of interference in ISM bands, which will continue to grow with the deployment of the several wireless IoT solutions [9]. Thus, performance and benchmarking of LPWAN technologies remains as a key open area of research.

## 4 Conclusions and Future Work

An empirical investigation of the uplink performance of Sigfox and LoRa has been presented in this paper. Both technologies have been tested and compared in a controlled environment under similar interference-free propagation conditions. As a result of the test, it was possible to identify key system parameters that can be useful in future studies, which shows the great potential of this type of testing. Under the specific configurations analyzed, the sensitivity values found were -124 dBm in RSSI, +9 dB in SNR and 147 dB in maximum average path loss for Sigfox; and -127 dBm in RSSI, -20 dB in SNR and 155 dB in maximum average path loss for LoRa. Due to measurement limitations, Sigfox live operation performance might be approximately 3 dB better in terms of SNR and 20 dB better in terms of RSSI and maximum path loss than the reported test values. Future plans include testing of end device power consumption, interference characterization, as well as the extension of the study to other LPWAN technologies such as LTE NB-IoT.

## Appendix

The reason for the deviations between the calibrated path loss (cPL) and the RSSI/SNR-based path loss (rPL/sPL) observed in the results can be explained by means of Fig. 6.

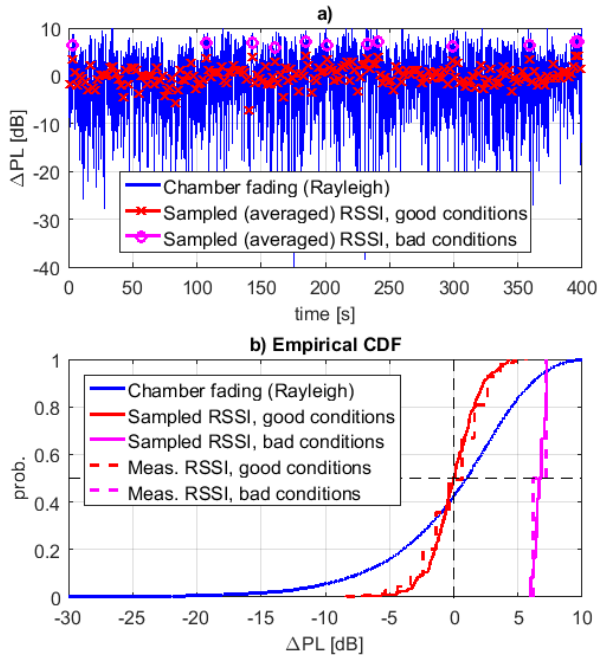

**Fig. 6:** a) Instantaneous signal variations, b) Statistical distribution of the signals.

Due to the multipath conditions inside the chamber, the overall path loss experienced during the test is affected by Rayleigh fading [7, 8]. For illustration purposes, we characterize it in Fig. 6.a as instantaneous fading variations ( $\Delta\text{PL}$ ) normalized to the average signal/path loss value (which is fixed by  $\text{cPL}$ , and proportional to  $L_{\text{att}}$ ). The key issue is the signal variations observed at the receiver side during the reception of the signal. In good conditions (low  $\text{cPL}$ ) the receiver is able to measure signals that are even in a fade, while in bad conditions (high  $\text{cPL}$ ) only signal peaks can be recorded due to receiver sensitivity limitations. In addition, the over-the-air time for the configured Sigfox and LoRa signals is approximately 2 s, the associated RSSI experiences a filtered version of the Rayleigh fading sampled/averaged over intervals of this period of time.

As it is shown in Fig. 6.b, which displays the same data presented in Fig. 6.a but in statistical form, the distribution from the sampled RSSI is then closer to a Gaussian distribution with mean ( $\text{RSSI}_{\text{avg}}$ ) equal to the average level from the Rayleigh fading distribution. Observe that the crossing of the red distribution exactly at  $\Delta\text{PL} = 0$  and note that the median of the blue distribution is shifted from this point as in the Rayleigh case, the average value, which is used in the normalization, is larger than the median. This is the case in good propagation conditions, where all the faded-signal variations are captured inside the base station receive window (i.e. average signal level clearly above the sensitivity level) and lead to equal values of  $\text{rPL}$  and  $\text{cPL}$ . In the case of bad propagation conditions, where the faded-signal is clipped by the receiver sensitivity level, a truncated RSSI distribution is experienced. In this case, the  $\text{RSSI}_{\text{avg}}$  value is different (larger) than the average value of the overall fading distribution, which leads to the observed deviations between  $\text{rPL}$  and  $\text{cPL}$  at the higher path loss values (with  $\text{rPL}$  being lower than  $\text{cPL}$ ). This reasoning

is further validated by showing the good agreement of two Sigfox RSSI measurement distributions over the analytical ones. The included measurements results were performed with  $L_{\text{att}}$  values of 78.6 dB ( $\text{cPL} = 115.1$  dB, good conditions) and 108.8 dB ( $\text{cPL} = 145.3$  dB, bad conditions). The same reasoning can be extrapolated to  $\text{sPL}$  as, in that case, the path loss is estimated from a RSSI prediction based on  $\text{SNR}_{\text{avg}}$ .

## Acknowledgments

This study is part of the AAU WCN research project IoT Living Lab, which is partly funded by Innovation Fund Denmark. The authors would like to express their gratitude to Sigfox for lending the base station equipment used in the measurements, as well as to Jørn Sørensen, member of the IoT Living Lab, for his hard work in implementing part of the measurement software control.

## References

- [1] U. Raza, et. al., “Low Power Wide Area Networks: An Overview”, *IEEE Communications Surveys & Tutorials*, vol. 19, no. 2 (2017).
- [2] K.E.Nolan, et. al., “An Evaluation of Low Power Wide Area Network Technologies for the Internet of Things”, International Wireless Communications and Mobile Computing Conference (2016).
- [3] K. Radim, et. al., “Ultra Narrow Band Radio Technology in High-Density Built-Up Areas”, International Conference on Information and Software Technologies (2016).
- [4] A. Augustin, et. al., “A Study of LoRa: Long Range & Low Power Networks for the Internet of Things”, *Sensors*, vol. 16, no. 9 (2016).
- [5] J. Petajärvi, et. al., “Performance of a Low-Power Wide-Area Network Based on LoRa Technology: Doppler Robustness, Scalability, and Coverage”, *International Journal of Distributed Sensor Networks*, vol. 13, no. 3 (2017).
- [6] M. Lauridsen, et. al., “Coverage Comparison of GPRS, NB-IoT, LoRa, and SigFox in a 7800 km<sup>2</sup> Area”, IEEE Vehicular Technology Conference-Spring (2017).
- [7] P.S. Kildal, et. al., “Characterization of Reverberation Chambers for OTA Measurements of Wireless Devices: Physical Formulations of Channel Matrix and New Uncertainty Formula”, *IEEE Transactions on Antennas and Propagation*, vol. 60, no. 8 (2012).
- [8] C.S.L. Patané, et. al., “Analysis and Improvement of Reverberation Chamber Method for Characterization of Small and Terminal Antennas”, European Conference on Antennas and Propagation (2011).
- [9] B. Vejlgård, et. al., “Interference Impact on Coverage and Capacity for Low Power Wide Area IoT Networks”, IEEE Wireless Communications and Networking Conference (2017).