

Tests of Four PT-415 Coolers Installed in the Drop-in Mode

Green^a, M. A., and Wang^b, S. T.

a) Lawrence Berkeley National Laboratory, Berkeley CA 94720, USA

b) Wang NMR Incorporated, Livermore CA 94550, USA

The superconducting magnets and absorbers for MICE will be cooled using PT415 pulse tube coolers. The cooler 2nd stage will be connected to magnets and the absorbers through a helium or hydrogen re-condensing system. It was proposed that the coolers be connected to the magnets in such a way that the cooler can be easily installed and removed, which permits the magnets to be shipped without the coolers. The drop-in mode requires that the cooler 1st stage be well connected to the magnet shields and leads through a low temperature drop demountable connection. The results of the PT415 drop-in cooler tests are presented.

INTRODUCTION

The final stage of the Muon Ionization Cooling Experiment MICE [1] will have a have seven superconducting magnet modules. The two spectrometer-magnet modules [2] have a uniform magnetic field section ($\Delta B/B < 10^{-3}$ over a length of 1 meter and a diameter of 0.3 meters) for analyzing particle data. The final stage of MICE will have three magnet absorber focus coil (AFC) modules [3] for focusing the muon beam so that ionization cooling can occur within a liquid hydrogen absorber [4] that is within the warm bore of the focusing magnet. The final stage of MICE has two RF coupling (RFCC) modules that contain four 201.25 MHz RF cavities [5]. The RF cavities are within the magnetic field generated by a short 1.5-m diameter coupling solenoid [6]. The magnets in the MICE cooling channel have no iron shield or active shield. As a result, there will be a magnetic field in the region outside of the cooling channel magnet cryostat.

Pulse tube coolers have been selected for use on the MICE cooling channel [7]. The primary reason for selection pulse tube coolers is that these coolers can be shielded so that they can operate in magnetic fields [8, 9] up to 0.3 T. The coolers that have been selected for cooling the MICE magnets and hydrogen absorbers are Cryomech PT415 coolers, which generate 1.5 W at 4.2 K while generating about 60 W of cooling at 50 to 55 K [10] – [12]. Based on the operating data for a PT410 cooler [13] at 20 K, the second stage of a PT415 cooler will produce from 15 to 20 watts of cooling depending on the temperature of the first stage. The PT415 cooler has roughly the same performance at 50 Hz as it does at 60 Hz, because the pulsing frequency is independent of the line frequency [13]. The only moving part in the cold of a typical GM cycle pulse tube cooler is the rotary valve in the cold head. The rotary valve motor is the part of a pulsed tube cooler that is most sensitive to magnetic field. It has been determined that a PT415 valve motor can be shielded for magnetic up to 0.3 T [8].

The magnetic field also affects the HTS leads that go into the superconducting magnet [9], [14]. The position of the cooler is determined by the magnetic field at the cooler and the magnetic field at the top of the HTS leads, which are very close to the cooler first stage. As a result, of the magnetic field from the MICE magnets, the coolers end up a long way from the magnet axis. Transport of the MICE magnets with the coolers in place may be difficult. It is desirable for the coolers to be shipped separately from the magnet and its cryostat. As a result, it is desirable to use drop in coolers on the MICE magnets. The use of drop-in coolers means that the coolers can be easily changed for maintenance.

Figure 1 shows the characteristics of a PT415 two stage pulse tube cooler [11], [15]. Figure 1 is a plot of the second stage temperature versus the first stage temperature versus the heat input into the cooler first-stage Q1 and the cooler second-stage Q2. The data shown with filled squares is the nominal performance diagram for a typical PT415 cooler. The data with the filled circles is the extended measurements done at Florida State University [11].

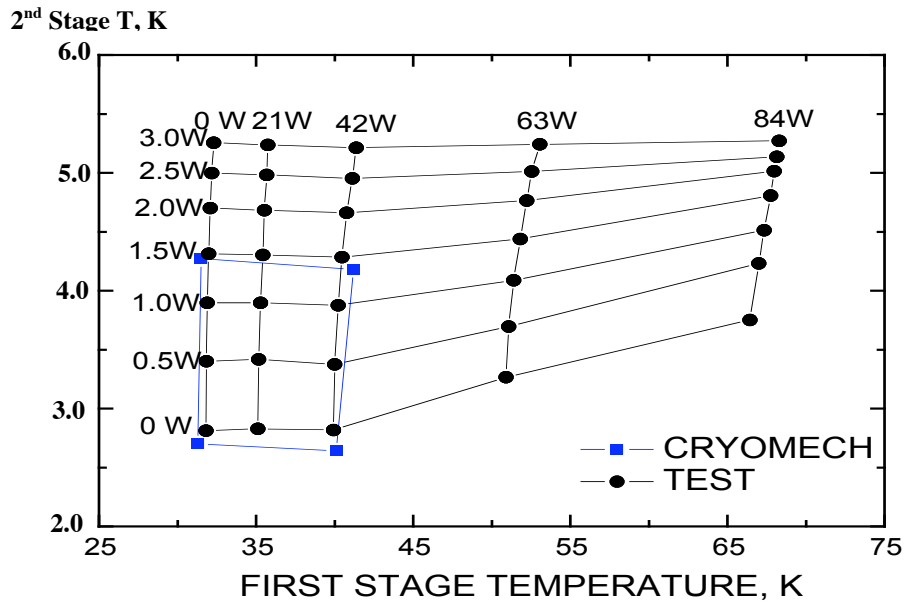

Figure 1. PT-415 Cooler Operating Diagram with up to 3 W on the 2nd Stage and up to 84 W on the 1st Stage

Table 1. The Operation Performance Parameters for the Four PT415 Coolers Tested in the Drop-in Cooler Test

Cooler	Q1 (W)	T1 (K)	Q2 (W)	T2 (K)
A	0	29.5	0	2.50
	0	31.8	1.5	4.15
	60.0	45.0	0	2.30
	59.0	45.0	1.5	3.90
B	0	28.0	0	2.30
	0	28.5	1.5	4.29
	42.4	42.3	0	2.35
	42.4	44.3	1.5	4.05
C	0	31.8	0	2.50
	0	32.2	1.5	3.95
	48.8	45.0	0	2.55
	44.3	45.0	1.5	3.90
D	0	31.3	0	2.86
	0	31.8	1.5	4.25
	42.5	41.8	0	2.78
	42.5	43.2	1.5	4.15

Table 1 shows the operating data for both stages of the four PT415 coolers that were tested. In Table 1, are the first-stage temperature T1, the first stage heat load Q1, the second-stage temperature T2, and the second-stage heat load Q2. Three of the four machines (coolers A, C and D) were pre-charged with helium gas at 16.8 MPa (230 psig). The fourth machine (cooler B) was charged to 14.7 MPa (200 psig). From Table 1, one can see that there is considerable variation from machine to machine even when they are charged to the same pressure. For example, the performance of the first stage of cooler A seems to be very good compared to the performance of the first-stages of the other coolers. The second-stage performance of cooler D doesn't appear to be as good as the performance of the other coolers. Cooler B, which was charged at a lower charging-pressure performs better on the second-stage than cooler D.

THE FIRST DROP-IN COOLER TEST SETUP

The first test set-up is shown in Figure 2. The test set-up shown in Figure 2 was designed to do a wide variety of tests. We had hoped to measure the cooler performance criteria similar to that done in Table 2 and Figure 1 while the space around the cooler was evacuated. Unfortunately the heat leaks appeared to be very high because the Cernox sensors were indicating a higher than normal temperature. There was a vacuum leak into the test volume as well. The test set-up shown in Figure 2 permitted us to test convective cooling of the helium tank and helium liquefaction from a source of gas at room temperature.

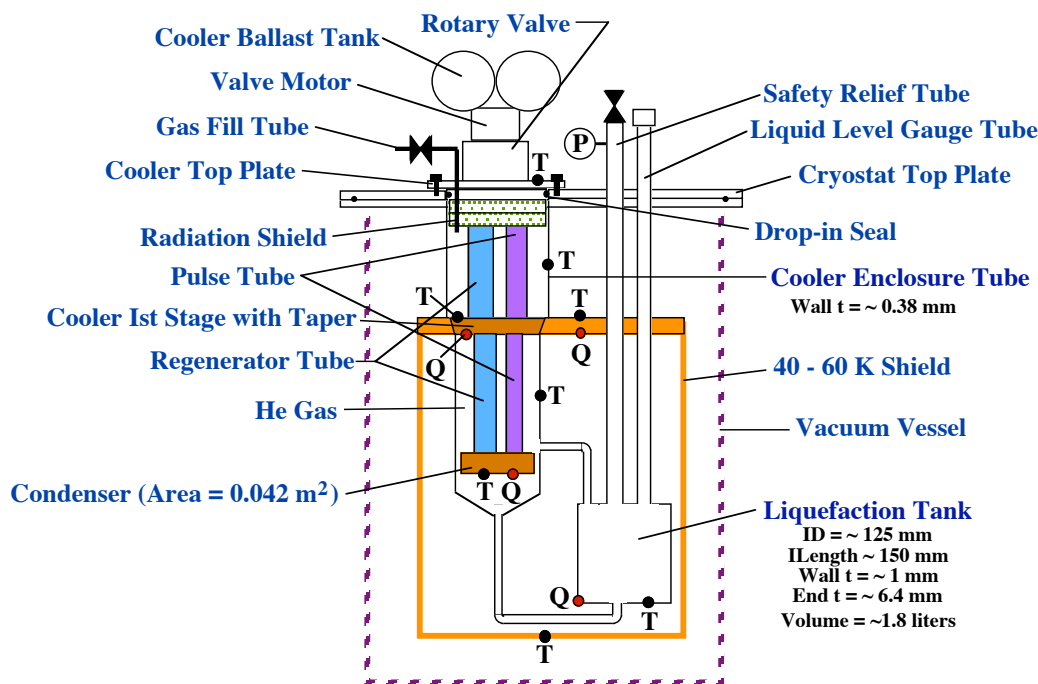

Figure 2. The Drop-in Cooler Test Set-up used for the First Cooler Test

As a way of characterizing the performance of the cooler, the first test was a bust. We filled the helium space around the coolers with helium gas through the helium gas fill tube. The cooler cooled down the helium and circulated the helium from the second-stage cold head to the bottom of the 1.8-liter helium tank. The tank was cooled from room temperature to about 4.3 K by free convection. This occurred even though the Cernox sensor on the second stage read no lower than 6.5 K. The Cernox sensor on the first stage gave us temperature readings above 38 K. After the experiment sat for some time, liquid helium began to collect in the helium tank. The system was liquefying helium, but the liquefaction rate was low (< 0.25 L/hr).

Re-condensation was achieved during the first test, but the highest amount of heat that could be put into the helium tank with the heater was only about 0.6 W. After analyzing the data, it appeared that there was a heat leak into the first stage of about 10 W. The added heating into the second stage seemed to be between 0.9 and 1.2 W, which was 0.7 to 1.0 W higher than expected. When heat was put into the first stage, there was still some re-condensation, but it didn't improve very much.

DROP-IN COOLER TEST SETUP FOR SUBSEQUENT SUCCESSFUL COOLER TESTS

The cooler test setup for subsequent successful cooler tests is shown in Figure 3. The changes from the first cooler test setup include; a larger helium tank, a different arrangement of the helium exit and inlet pipes around the condenser. It was thought that reduced re-condensation performance in the first test was due to the boil off helium from the helium being mixed with warmer helium between stages. The second test setup feed the return helium below the re-condenser. All temperatures were read using Cernox and Pt resistor sensors on the outside of the cooler sleeve. There were no temperature sensors in the helium space, because it was thought that this may have contributed to poor re-condensation performance in the first test. Figure 4 shows the cooler second-stage condenser and baffles between cooler the cooler stages.

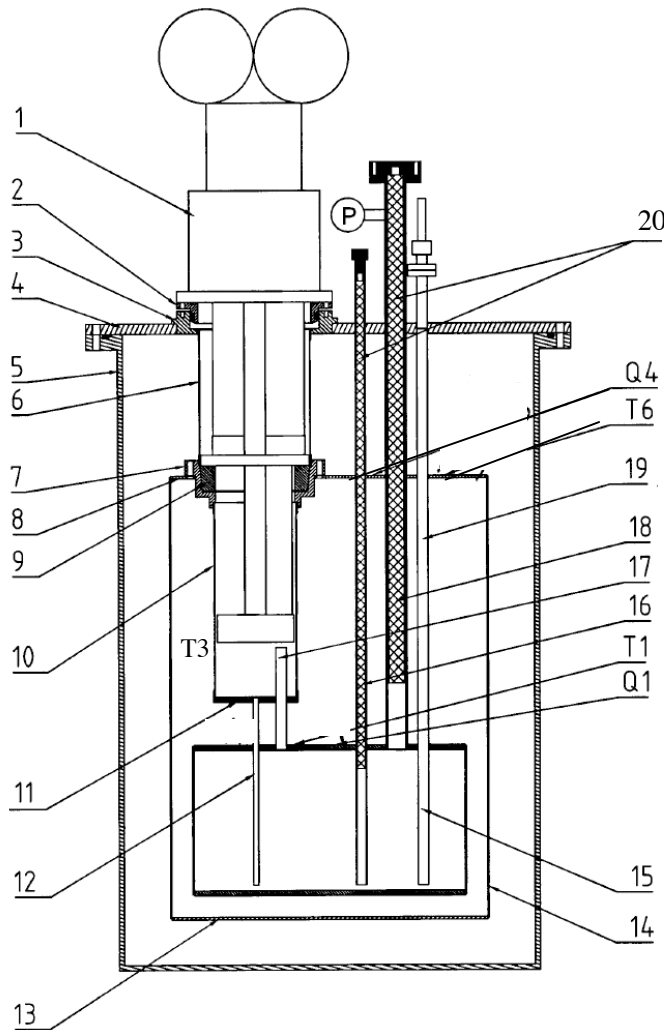

1. PT415 Cooler
2. Cooler Adaptor
3. 300 K Sleeve Flange
4. Cryostat Top Plate
5. Cryostat Vacuum Vessel
6. Cooler Sleeve-1
7. Copper Sleeve Flange
8. Copper 60 K Shield Top Plate
9. First Stage Adaptor
10. Cooler Sleeve-2
11. Cooler Sleeve-2 Bottom Plate
12. Liquid Helium Tube to Tank
13. Copper 60 K Bottom Plate
14. Copper 60 K Enclosure Tube
15. 4.2 Liquid Helium Can
16. Helium Gas Tube to Condenser
17. Helium Vent Tube to 300 K
18. Liquid Helium Fill Tube
19. Liquid Level Gauge Tube
20. Thermal Acoustic Oscillation Plug

Q1 and Q4 are Heaters, T1, T3 and T6 are Temperature Sensors.

The thermal acoustic oscillation plugs were used during some of the tests. It was clear that thermal acoustic oscillations were a problem at times during the tests. The temperature sensor on the helium can was moved to various positions on the helium can.

Figure 3. The Drop-in Cooler Test Set-up used for Successful Subsequent PT415 Cooler Tests



Figure 4. First Stage Pressed Tapered Fit (left), Second Stage Condenser (right), and Baffles between the Stages

The condenser shown in Figure 4 has a vertical surface area of 0.042 m^2 . The length of the vertical section is about 45 mm. There was some question as to whether the condenser area was adequate. When one looks at the theory of condensation [16, 17], it is clear that the condenser area is adequate for the range of temperatures and pressures the condenser is designed for. The shortness of the condenser is a positive factor in its performance. More important may be where the helium gas is fed into the condenser.

SOME TEST RESULTS FOR THE DROP-IN COOLER TESTS

The first time that cooler A was run in the test setup shown in Figure 3, the results were worse than they were when the same cooler was run in the test setup shown in Figure 2. The cooler test setup did not liquefy helium. Helium fed into the system from the tank did not become liquid. If one wants to liquefy helium, one must feed the helium gas into the helium space above the first stage. None of the Cernox thermometry read correct temperatures including the sensors that were connected directly to a tank filled with liquid helium. During the first run of the new drop-in cooler test setup re-condensation was poor. The experiment behaved as if the heat leak into the 4 K region was over 1.2 W. The platinum-resistance temperature-sensors gave us reliable temperature measurements on the shield and the ring that was press fitted to the cooler first stage. From the temperatures measured, it appeared that the heat leak to the first stage was no more than a few watts. There were heated discussions as to whether the coolers were the problem or whether something else was the problem. It is now believed that thermal acoustic oscillations in the helium fill and vent pipes were the culprits. When the thermal acoustic control plugs were put into the fill and vent pipes the performance the drop-in coolers became acceptable. Unfortunately, a number of other changes were made in the experiment. One of the changes was the use of high-thermal-conductivity grease in the connection between the cooler first-stage and the copper ring that is attached to the shield.

Table 2 is a summary of the results a number of the test runs that were made with the cooler test setup shown in Figure 3 in March 2008.

Table 2. A Summary of the Results of Some of the Drop-in Cooler Tests in March 2008

Cooler	Q1 (W)	T1 (K)	Q4 (W)	T6 (K)
B	0.4	3.46	0	31.5
B	0.4	3.44	55	56.7
B	1.15	4.01	55	56.9
B	1.10	3.99	55	56.9
B	1.20	4.04	55	56.9
B	1.25	4.11	55	57.1

The coolers were tested under the following conditions: 1) All four coolers were tested with G-10 thermal acoustic suppression plugs were in the helium vent and the helium fill line. 2) Most of the tests were run without the shield plates shown in Figure 4. There was no difference in the cooler performance with and without the shield plates. 3) Re-condensation was tested with heaters Q1 set at 0.5 W, 1.0 W, 1.25 W, and 1.5 W. 4) Heater Q4 was set at a range of values between 0 and 55 W. Most of the tests were done with the heaters set at 40 W and 50 W. 5) A cold removable contact was used for three of the coolers A, C and D. The test shown in Table 2 were the ones that were done with the conductive grease in the contact. When the contact has grease in it, the cooler is not easily removable while cold. A fresh copper surface in the contact region was used for two of the coolers. When the contact didn't have grease in it, the temperature at T6 appeared to be a little higher. 7) The liquid in the tank ranged from 10 to 17 L.

The test results can be summarized as follows: 1) All four coolers could operate with $Q1 = 1.25 \text{ W}$ at a temperature less than 4.2 K and with $Q4$ at 40 W. 2) One cooler could operate with $Q1 = 1.5 \text{ W}$ and $Q4$ at 50 to 55 W. 3) Whenever the cooler is installed with the first stage contact cold, the first stage contact had to be pushed down slowly until the seal was achieved. 4) When $Q4$ was large ($> 40 \text{ W}$) the first stage

warmed up and the re-condensation performance was diminished. 5) When Q_1 was > 1.5 W, the pressure in the helium tank built up to 0.12 MPa and beyond. The equivalent temperature was greater than 4.43 K. At a pressure of 0.12 MPa, the relief valve leaked and liquid was eventually boiled away. 6) As long as Q_1 was less than or equal to 1.25 W and Q_4 was less than or equal to 40 W there was no problem with re-condensation with any of the four coolers. 7) When Q_4 was zero, the second stage got colder and re-condensation was was. This may not be real because of the long time constants involved within the experiment. Having a large helium tank means that changes within the cooler experiment occur slowly. Further cooler experiments will be run with silicon diode temperature sensors on the helium tank and the sleeve outside of the condenser attached to the second stage. None of the Cernox sensors read correctly.

The cooler experiment demonstrated that PT415 coolers can be operated re-condensers in the drop-in mode. As a result, the MICE tracker solenoid was assembled with three drop-in 415 coolers. The MICE tracker solenoid has three pairs of 300 A leads in addition to a single pair of 60 A leads. The estimated heat load on the first stage of the coolers is greater than 110 W. If the tracker magnet cryostat heat leak at 4.2 K is less than 3.75 W, the three coolers should be able handle the load without boiling helium. This performance had not been demonstrated at the time this paper was written.

ACKNOWLEDGMENT

This work was also supported by the Office of Science, United States Department of Energy, under DOE contract DE-AC02-05CH11231. DOE funding for the US Neutrino Factory and Muon Collider Collaboration is also gratefully acknowledged.

REFERENCES

1. Gregoire, G., Ryckewaert, G., Chevalier, L. et al, "MICE and International Muon Ionization Cooling Experiment Technical Reference Document," <http://hep04.phys.iit.edu/cooldemo> (2004)
2. Green, M. A. Chen, C. Y., Juang, T. et al, "Design Parameters for the MICE Tracker Solenoid," *IEEE Transactions on Applied Superconductivity* **17**, No. 2, p 1247, (2007)
3. Yang, S. Q., Green, M. A., Barr, G. et al, "The Mechanical and Thermal Design for the MICE Focusing Solenoid System," *IEEE Transactions on Applied Superconductivity* **15**, No. 2, p 1259, (2005)
4. Baynham, D. E., Bish, P., Bradshaw T. T. et al, "A Liquid Cryogen Absorber for MICE," *Advances in Cryogenic Engineering* **51**, p 1068, AIP Press, Melville New York, (2006)
5. Li, D., Green, M. A., Virostek, S. P., Zisman, M. S. et al, "Progress on the RF Coupling Coil Module Design for the MICE Cooling Channel," *Proceedings of the 2005 Particle Accelerator Conference*, Knoxville TN, p 3417, (2005)
6. Wang, L., Green, M. A., Xu, F. Y. et al, "The Engineering Design of the 1.5 m Diameter Solenoid for the MICE RFCC Modules," *IEEE Transactions on Applied Superconductivity* **18**, No. 2, p 937, (2008)
7. Green, M. A., "Cooling the MICE Magnets using Small Cryogenic Coolers," Oxford Physics Note 10, MICE Note 109, <http://hep04.phys.iit.edu/mice/notes/notes.html>, 10 September 2004
8. Green, M. A. and Witte, H., "The Use of Small Coolers in a Magnetic Field," *Advances in Cryogenic Engineering* **53**, p 1299, AIP Press, Melville New York, (2008)
9. Green, M. A., Yang, S. Q., Cobb, J. et al, "The Effect of Magnetic Field on the Position of HTS Leads and the Cooler in the Services Tower of the MICE Focusing Magnet," *IEEE Transactions on Applied Superconductivity* **18**, No. 2, p 1447, (2008)
10. PT-415 Pulse Tube Cooler Brochure, Cryomech Inc. <http://www.cryomech.com>
11. Private communication with Tom Painter, Florida State University concerning the performance of a PT415 cooler over a range of temperatures and heat loads.
12. Choi, Y. S., Painter, T. A., Kim, D. L. et al, "Helium-Liquefaction by Cryocooler for High-Field Magnets Cooling," *Proceedings of the International Cryocooler Conference* 14, June 2006
13. Private communication with Chao Wnag Cryomech Inc. Operating Data for the PT410 Pulse Tube Cooler
14. Green, M. A. and Witte, H., "Using High Temperature Superconducting Leads in a Magnetic Field," *Advances in Cryogenic Engineering* **53**, p 1251, AIP Press, Melville NY, (2008)
15. Green, M. A., "Liquefaction of Hydrogen and Helium using Small Coolers," LBNL-62458, 12 Feb. 2007, MICE Note 161, <http://hep04.phys.iit.edu/mice/notes/notes.html>
16. Taylor C. E., Abbott, S. R. Leitner, D., et al, "An Efficient Cooling Loop for Connecting a Cryocooler to a Helium Reservoir," *Advances in Cryogenic Engineering* **49**, p 1818, AIP Press, Melville NY (2004)
17. Green, M. A., Dietderich, D. R., Marks, S., et al "Design Issues for Cryogenic Cooling of Short Period Superconducting Undulators," *Advances in Cryogenic Engineering* **49**, p 783, AIP Press, Melville NY (2004)

DISCLAIMER

This document was prepared as an account of work sponsored by the United States Government. While this document is believed to contain correct information, neither the United States Government nor any agency thereof, nor The Regents of the University of California, nor any of their employees, makes any warranty, express or implied, or assumes any legal responsibility for the accuracy, completeness, or usefulness of any information, apparatus, product, or process disclosed, or represents that its use would not infringe privately owned rights. Reference herein to any specific commercial product, process, or service by its trade name, trademark, manufacturer, or otherwise, does not necessarily constitute or imply its endorsement, recommendation, or favoring by the United States Government or any agency thereof, or The Regents of the University of California. The views and opinions of authors expressed herein do not necessarily state or reflect those of the United States Government or any agency thereof, or The Regents of the University of California.