

The Automated Complex Impedance Measurement System

V. Dumbrava, L. Svilainis

Department of Signal Processing, Kaunas University of Technology,

Studentu str. 50, LT-51368 Kaunas, Lithuania, tel.: +370 37 300532, e-mail: vydum@ktu.lt

Introduction

Modern impedance measuring instruments measure the real and the imaginary parts of an impedance vector and are able to operate in wide frequency range covering 10 Hz up to 10 GHz [1]. The complex impedance is an important parameter characterizing the electronic circuits, components, and the materials [2]. Sensor impedance can be used when preamplifier noise performance is evaluated [3]. Also impedance measurements are employed when wideband transformer model parameters are to be measured [4]. The automated measurement is not possible for low end instruments, the covered the frequency range up to 100 kHz [5]. The high end equipment dedicated for industrial measurements is capable of automated measurements, exhibits very high accuracy and covers wide frequency range [6] but is expensive.

We are frequently involved in electrical impedance measurements within 20 kHz to 20 MHz frequency range in our research. The impedance values measured are within few ohms to dozen kilo ohms. Accuracy of a few percents would be enough for the measurements mentioned therefore low cost of such system could be expected. The requirement usually is to measure not just at single frequency or operating conditions but at multiple frequencies and certain set of operation values. Therefore the measurement automation is essential, as well as the price of the equipment.

The design of complex impedance measurement system satisfying our specific needs is presented below.

Impedance measurement methods analysis

A variety of methods for impedance measurement exists [1]: bridge, resonant, I-V, RF I-V, network analysis.

The bridge method exhibits high accuracy, but due to the need of balancing this method we consider not suitable for our application. Resonant method is achieving good accuracy in quality of inductance measurement, but there is a need for resonance tuning. It can be considered as an option for few measurements as it was done in [2], but it is not suitable for low cost automated system. The rest of methods can be considered as candidates.

The analysis of industrial impedance measurement equipment using transmission/reflection (Γ , S – parameter, π network), I-V, RF I-V and auto-balancing bridge methods was found in source [7]. Data found in this publication is presented in Fig. 1. The impedance value and measurement frequency limits for 10 % of the impedance accuracy for the every method are shown. The range of our measurements is indicated as thick solid line.

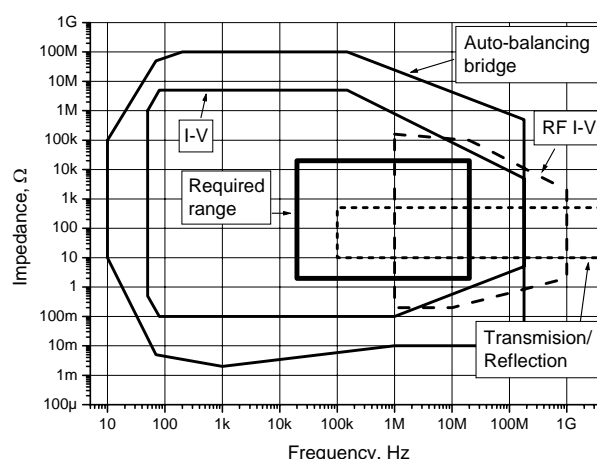

Fig. 1. Impedance measurement methods characterization

The Fig. 1 data analysis indicates that I-V and auto-balancing bridge methods look the most promising. In further analysis we concentrate on these two methods.

The I-V method

The measured impedance Z_x can be calculated using Ohm's law from the voltage and current values:

$$Z_x = \frac{\bar{U}_1}{\bar{I}} R_{\text{ref}}; \quad (1)$$

where \bar{U}_1 is a voltage across the unknown impedance Z_x and \bar{I} is the flowing current. If the mentioned voltage and current are obtained directly such technique is named I-V.

The simplified I-V method connection diagram is presented in Fig. 2.

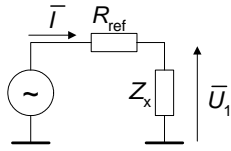

Fig. 2. Simplified I-V method schematic

Current can be calculated using the voltage drop measurement across an accurately known reference resistor R_{ref} . Placement of R_{ref} at high end impedes the requirement to accurately measure the differential signals in the presence of high common-mode voltages. Usually a specialized operational amplifier is used for this purpose. Sometimes an RF transformer is used in place of R_{ref} to obtain the high-end sensor [8]. The RF transformer, however, limits the lower end of the applicable frequency range. However, the R_{ref} voltage drop can be calculated by taking the difference of single-ended voltages on R_{ref} [9]. The modified measurement diagram is presented in Fig. 3.

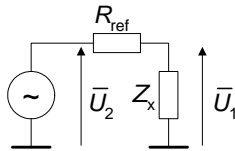

Fig. 3. Modified schematic for I-V method

Then an unknown impedance Z_x is calculated as

$$Z_x = \frac{\bar{U}_1}{\bar{U}_2 - \bar{U}_1} R_{ref}. \quad (2)$$

Such a measurement setup requires only one high-impedance measurement path for voltage U_1 (channel 1). The voltage U_2 can be monitored using a 50Ω impedance path (channel 2).

Auto-balancing bridge method

The auto-balancing bridge employs the inverting topology operational amplifier. Turn to drawing on Fig.4 for explanatory schematic.

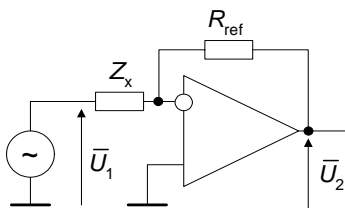

Fig. 4. Basic schematic for auto-balancing bridge method

The current flowing through Z_x is mirrored by the resistor R_{ref} current. The potential at the operational amplifier inverting pin is maintained at zero (sometimes called a „virtual ground“). I.e. the current through R_{ref} balances with the Z_x current by operation of the I-V converter amplifier. The Z_x current is calculated using voltage measurement at the operational amplifier output

$$Z_x = \frac{\bar{U}_1}{\bar{U}_2} R_{ref}. \quad (3)$$

This mode of measurement has a disadvantage in accuracy at high frequencies because of the operational amplifier performance limit.

The measurement system

The acquisition system for automated AC parameters measurement [10] has been used as the base for impedance measurement arrangement. The new system structure for impedance measurement in I-V mode is presented in Fig. 5. System contains the excitation signal generation and resulting waveforms collection units. Two simultaneous 10 bits analog-to-digit converters (ADC) are available. The data can be streamed at 100 Ms/s into two independent 256k samples deep memory banks. The system control and data collection is performed by the host PC via a high speed USB2 interface. The communication with the host computer is accomplished using the Cypress Semiconductor EZ-USB FX2LP highly integrated, low-power USB2.0 microcontroller IC CY7C68013A. Such architecture allows for fast and automated measurement.

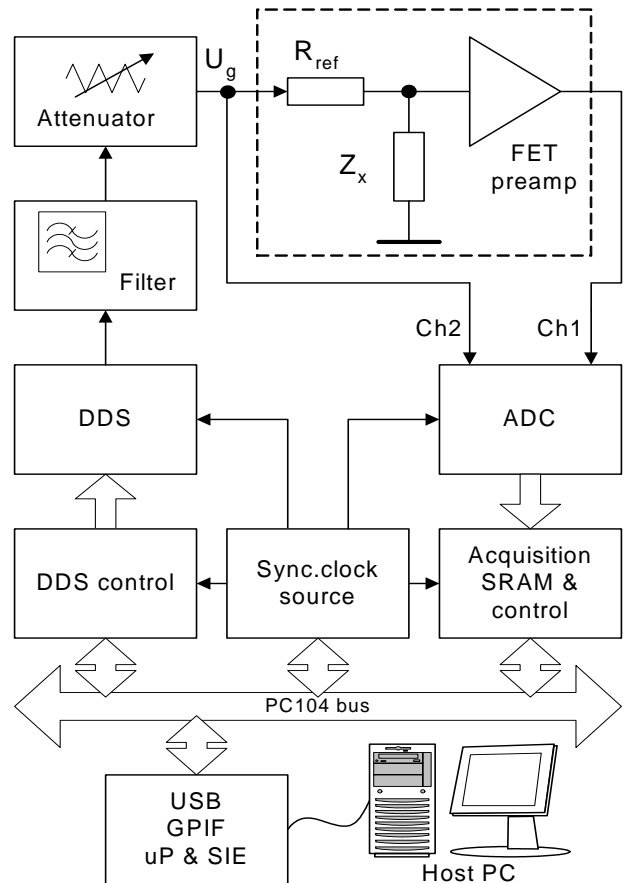

Fig. 5. System structure for I-V method

The system can be easily converted into auto-balancing bridge measurement mode by applying the modifications presented in Fig. 6.

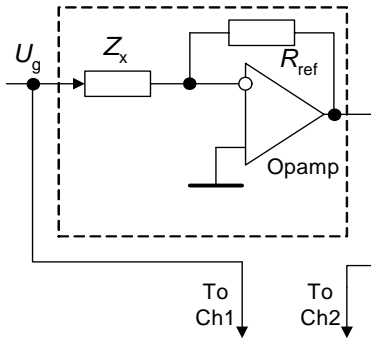

Fig. 6. System modification for auto-balancing bridge method

The amplitude and phase estimation in the presence of noise turns difficult. The use of sine-fitting technique can significantly reduce the noise. The fitting function is:

$$u(t) = U_c \cos(2\pi ft) + U_s \sin(2\pi ft) + U_0; \quad (4)$$

where U_c and U_s are the in-quadrature amplitudes, U_0 is the DC component and f is the excitation frequency. This method is useful if the excitation frequency is not known. It should be noted that impedance measurement system (refer Fig. 5) is using common synchronization clock source both for exciting signal generation and waveform acquisition. In such case the sine fitting can be simplified since excitation signal frequency and acquisition sampling rate ratio is exactly known. The reference frequency will be insignificant. Furthermore, if signal containing only single frequency is used for excitation then sine wave correlation (SWC) technique [12] can be applied to extract the signal amplitude and phase by using cosine and sine signals for correlation. Fitting the function (4) to the signal as a set of M samples, $y_1 \dots y_M$, acquired at a frequency f_s at time instances $t_1 \dots t_M$ then is accomplished as:

$$U_c = \frac{\sum_{m=1}^M [\cos(2\pi f t_m) \cdot y_m]}{\sum_{m=1}^M [\cos(2\pi f t_m)]^2}, U_s = \frac{\sum_{m=1}^M [\sin(2\pi f t_m) \cdot y_m]}{\sum_{m=1}^M [\sin(2\pi f t_m)]^2}. \quad (5)$$

Then the measured signal magnitude and phase is

$$U = \sqrt{U_c^2 + U_s^2}, \varphi = \arctan\left(\frac{U_s}{U_c}\right). \quad (6)$$

Same computational procedure has to be performed on both system channels (voltages \bar{U}_1 and \bar{U}_2 are obtained).

The application examples

In order to test the system functionality the complex test impedance has been manufactured. The model circuit is composed of 1 k Ω and 91 pF capacitor (both surface mount) connected in parallel. It has been measured using both the I-V and the auto-balancing bridge methods. Measurements frequency range was 100 kHz to 20 MHz. The results are presented in Fig. 7.

The real and imaginary impedance parts are plotted against individual axes. The real part axis is on the left and

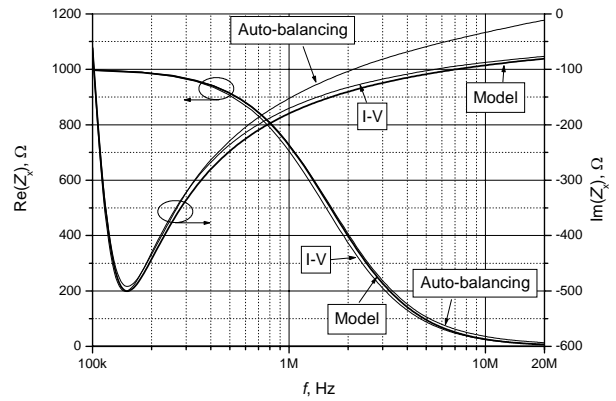

Fig. 7. Impedance measurement performance evaluation

the imaginary part is using the scale on the right. The values of components constituting the impedance model (resistor and capacitor) have been used for theoretical impedance calculation. This calculation result is presented on Fig. 7 graph as thick line. It can be seen that there is some results deviation at high frequencies. The impedance deviation is significant when frequency is above 1 MHz for the results obtained using the auto-balancing bridge method. This measurement accuracy is decrease can be explained by performance limits of the operational amplifier at high frequencies. As indicated in [1] the LCR meters using the auto-balancing bridge technique can utilize a simple operational amplifier for low frequency range (typically below 100 kHz). Wideband LCR meters and impedance analyzers for frequencies above 1MHz employ the combination of sophisticated null detector, phase detector, a loop filter and vector modulator to ensure a high accuracy for a broader frequency range.

The electrical model Butterworth Van Dyke (BVD) transducer [3] has been measured. The comparison of the measurement results and the theoretical impedance based on the components values is presented in Fig. 8.

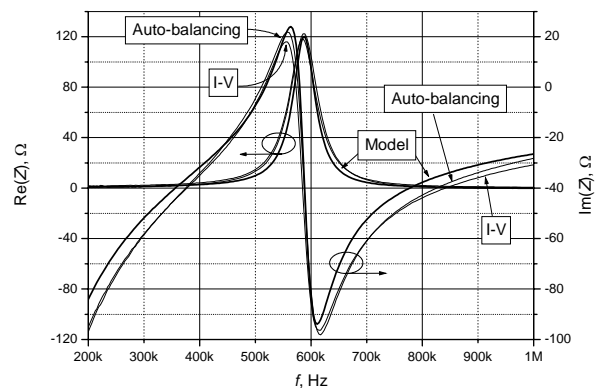

Fig. 8. Measured vs. theoretical impedance of transducer model

Both measurement techniques are giving similar results. It was indicated in publication [3] that the use of the real source impedance allows better performance prediction and the topology of the circuit can be modified to obtain the best available signal-to-noise ratio.

The fast impedance measurement is needed for the impedance variation monitoring. Refer to Fig. 9 impedance measurement example in changing load conditions.

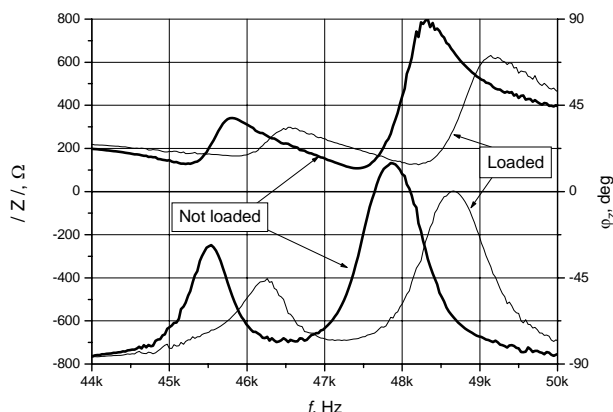

Fig. 9. Actuator impedance change with load

The graphs in Fig. 9 represent the module and the phase of the mechatronic system motor piezoactuator in loaded and unloaded conditions. By monitoring the impedance change the optimal motor driving conditions can be estimated.

Conclusions

The design of impedance measurement system satisfying our specific needs is presented. The preliminary investigation results presented indicate system measurement capabilities of parallel RC circuit and transducer BVD electrical model. The performance in the frequency range above 1MHz is complicated for auto-balancing bridge method. It is planned to develop the compensation technique for accuracy improvement in high frequency range.

The piezoactuator impedance variation investigation is a good demonstration of system monitoring capabilities.

References

1. Impedance Measurement Handbook. Agilent Technologies Co. Ltd. USA.- 2003.
2. Sheen J. Study of microwave dielectric properties measurements by various resonance techniques// Measurement. – 2005. – Vol.37, No.2. – P. 123–130.
3. Dumbrava V., Svilainis L. Noise model for ultrasonics transducer preamplifier // Electronics and Electrical Engineering. – 2006. – Vol. 66, No.2. – P. 21–25.
4. Trask Ch. Designing Wide-band Transformers for HF and VHF Power Amplifiers // QEX Communications Quarterly. – 2005. – No.2. – P.3–15.
5. High Precision LCR Meter LCR-800 series. Product catalog. Instek. – 2004.
6. Precision Impedance Analyzer 4294A Agilent Technologies Co. Ltd. USA. – 2003.
7. Eight Hints for Successful Impedance Measurements Application Note 346–4. -Agilent Technologies, USA. – 2000.
8. Yokoshima I. RF Impedance Measurements by Voltage-Current Detection // IEEE Transactions on Instrumentation and measurement. – 1993. – Vol.42, No.2. – P. 524–527.
9. Angrisania L., Ferrigno L. Reducing the uncertainty in real-time impedance measurements // Measurement. – 2001. – Vol. 30. – P. 307–315.
10. Svilainis L. The AC parameters measurement system for ultrasonics // Ultrasound. – 2006. – Vol.60, No. 3. – P. 44–48.
11. Silva M., Ramos P. M. et.al. A new four parameter sine fitting procedure // Measurement. – 2004. – Vol.35, No.2. – P.131–137.
12. Svilainis L., Dumbrava V. Amplitude and phase measurement in acquisition systems // Measurements. – 2006. – Vol.38, No.2. – P. 21–25.

Submitted for publication 2007 03 01

V. Dumbrava, L. Svilainis. The Automated Complex Impedance Measurement System // Electronics and Electrical Engineering. – Kaunas: Technologija, 2007. – No. 4(76). – P. 59–62.

The design of automated, low cost, complex impedance measurement system is described. The overview of impedance measurement methods is given and suitable candidates outlined. The I–V method and the auto–balancing bridge method have been selected and the system structure has been adopted for those two methods. The preliminary investigation results for both methods are presented. The parallel RC circuit and transducer BVD electrical model have been used as test impedance. The measurement results are plotted against theoretical impedance value. The piezoactuator impedance variation versus load was measured as demonstration of system monitoring capabilities. III.9, bibl.12 (in English; summaries in English, Russian and Lithuanian).

V. Думбрава, Л. Свилайнис. Система для измерения комплексного импеданса // Электроника и электротехника. – Каунас: Технология, 2007. – № 4(76). – С. 59–62.

Описана автоматизированная, недорогая система для измерения комплексного импеданса. Исследованы методы для измерения импеданса и отобраны подходящие кандидаты. Показано, что методы I–V (ток–напряжение) и автобалансного моста наиболее подходят для измерений в заданном диапазоне. Структура системы подобрана для обоих методов. Предварительные результаты измерений представлены для обоих методов. Цепочка RC и электрическая BVD модель преобразователя использованы в качестве тестового импеданса. Результаты измерений приведены в графиках вместе с теоретическими значениями импеданса. Изменение импеданса под влиянием нагрузки приведено в качестве демонстрации возможностей системы в режиме мониторинга. Ил.9, библ.12 (на английском языке; рефераты на английском, русском и литовском яз.).

V. Dumbrava, L. Svilainis. Automatizuota kompleksinio impedanso matavimo sistema // Elektronika ir elektrotechnika. – Kaunas: Technologija, 2007 – Nr. 4(76). – P. 59–62.

Pristatomas nebrangios, automatizuotos kompleksinio impedanso matavimo sistemos projektavimas. Nagrinėjami impedanso matavimo metodai ir pateikiami tinkami kandidatai. I–V (srovė–įtampa) ir auto-balansinio tiltelio metodai buvo atrinkti kaip tinkami. Sistemos struktūra parinkta, kad tiktų abiem metodams. Pateikti preliminarūs kompleksinio impedanso matavimo rezultatai. Lygiagreti RC grandinė ir keitiklio BVD elektrinis modelis buvo panaudoti sistemai testuoti. Gauti rezultatai braižyti kartu su teorinėmis impedanso vertėmis. Sistemos pritaikymui impedanso stebėsenai parodyti pateikiamas pjezovaldiklio impedanso kitimas veikiant apkrovai. Il.9, bibl.12 (anglų kalba; santraukos anglų, rusų ir lietuvių k.).