

RR 333

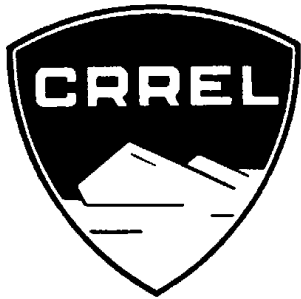

Research Report 333

**THE BEARING CAPACITY OF
FLOATING ICE PLATES SUBJECTED TO
STATIC OR QUASI-STATIC LOADS
A Critical Survey**

Arnold D. Kerr

March 1975

PREPARED FOR
ADVANCED RESEARCH PROJECTS AGENCY
ARPA ORDER 1615
BY
CORPS OF ENGINEERS, U.S. ARMY
COLD REGIONS RESEARCH AND ENGINEERING LABORATORY
HANOVER, NEW HAMPSHIRE

The findings in this report are not to be construed as an official Department of the Army position unless so designated by other authorized documents.

REPORT DOCUMENTATION PAGE		READ INSTRUCTIONS BEFORE COMPLETING FORM										
1. REPORT NUMBER Research Report 333	2. GOVT ACCESSION NO.	3. RECIPIENT'S CATALOG NUMBER										
4. TITLE (and Subtitle) THE BEARING CAPACITY OF FLOATING ICE PLATES SUBJECTED TO STATIC OR QUASI-STATIC LOADS, A Critical Survey	5. TYPE OF REPORT & PERIOD COVERED											
	6. PERFORMING ORG. REPORT NUMBER											
7. AUTHOR(s) Arnold D. Kerr	8. CONTRACT OR GRANT NUMBER(s) Contract No. DACA-70-C-0022 ARPA Order 1615											
9. PERFORMING ORGANIZATION NAME AND ADDRESS Arnold D. Kerr	10. PROGRAM ELEMENT, PROJECT, TASK AREA & WORK UNIT NUMBERS											
11. CONTROLLING OFFICE NAME AND ADDRESS Advanced Research Projects Agency Washington, D.C.	12. REPORT DATE March 1975											
	13. NUMBER OF PAGES 49											
14. MONITORING AGENCY NAME & ADDRESS (if different from Controlling Office) U.S. Army Cold Regions Research and Engineering Laboratory Hanover, New Hampshire 03755	15. SECURITY CLASS. (of this report) Unclassified											
	15a. DECLASSIFICATION/DOWNGRADING SCHEDULE											
16. DISTRIBUTION STATEMENT (of this Report) Approved for public release; distribution unlimited.												
17. DISTRIBUTION STATEMENT (of the abstract entered in Block 20, if different from Report)												
18. SUPPLEMENTARY NOTES												
19. KEY WORDS (Continue on reverse side if necessary and identify by block number)												
<table border="0"> <tr> <td>Bearing capacity of ice plates</td> <td>Quasi-static loads</td> </tr> <tr> <td>Elasticity theory of floating plates</td> <td>Static loads</td> </tr> <tr> <td>Floating ice plates</td> <td>Viscoelastic theories</td> </tr> <tr> <td>Limit analysis</td> <td>Yield line theory</td> </tr> <tr> <td>Literature survey</td> <td></td> </tr> </table>			Bearing capacity of ice plates	Quasi-static loads	Elasticity theory of floating plates	Static loads	Floating ice plates	Viscoelastic theories	Limit analysis	Yield line theory	Literature survey	
Bearing capacity of ice plates	Quasi-static loads											
Elasticity theory of floating plates	Static loads											
Floating ice plates	Viscoelastic theories											
Limit analysis	Yield line theory											
Literature survey												
20. ABSTRACT (Continue on reverse side if necessary and identify by block number)												
<p>This report contains a critical survey of the literature on the bearing capacity of floating ice plates. It consists of a discussion of general questions, a critical survey of analytical attempts to determine the bearing capacity of floating ice plates, and a survey of field and laboratory tests on floating ice plates and their relation to the analytical results. The paper concludes with a systematic summary of the results, a discussion of observed shortcomings, and suggestions for needed investigations.</p>												

PREFACE

This report was prepared by Dr. A.D. Kerr, Department of Civil and Geological Engineering, School of Engineering and Applied Science, Princeton University.

The work was performed as part of the Advanced Research Projects Agency Arctic Surface Effect Program, under ARPA Order 1615 and Contract No. DACA-70-C-0022.

The study was monitored by G.E. Frankenstein and was under the general direction of A.F. Wuori, Chief, Applied Research Branch, Experimental Engineering Division, U.S. Army Cold Regions Research and Engineering Laboratory.

This report was technically reviewed by D.E. Nevel of the U.S. Army Cold Regions Research and Engineering Laboratory.

CONTENTS

	Page
Preface	ii
Introduction.....	1
Analogy method	2
Method based on the bending theory of elastic plates and the criterion $\sigma_{\max} = \sigma_f$	4
Methods based on viscoelastic theories	18
Methods based on the yield line theory or limit analysis	22
Comparison of analytical and test results	24
General remarks	24
Effect of bending and shearing forces on deflection of an ice cover.....	25
Determination of $P_f(0)$	27
Determination of $P_f(t)$	31
Determination of σ_f	31
Summary and recommendations	32
Literature cited	34

ILLUSTRATIONS

Figure		
1.	Correction coefficient as related to failure stress	4
2.	A floating ice plate subjected to a distributed load q over a circular area of radius a	5
3.	$C(a)$ vs a graph	5
4.	$P_{cr}/\sigma_f h^2$ vs a	7
5.	A comparison of approximations for P_{cr} with exact graph.....	9
6.	Semi-infinite plate with free edge subjected to load P	9
7.	Comparison of analytical results	10
8.	$(P_{cr})_{\text{inf pl}}/(P_{cr})_{\text{semi inf pl}}$ vs b/l	10
9.	Semi-infinite floating plate, simply supported along the straight edge and subjected to a load P	11
10.	A floating rectangular corner plate with free edges subjected to load P at the corner	12
11.	Floating wedge shaped plate of opening angle ϕ subjected to load P at the tip.....	13
12.	Failure mechanism of a floating semi-infinite plate subjected along the free edge to a load P	14
13.	Failure mechanism for a large floating plate subjected to a load P	14
14.	Wedge shaped plate subjected to a load $P = qb$	15
15.	Stress distribution in the plate for a given $E(z)$	18
16.	Deflection-vs-time curves for a floating ice plate and fixed loads	18
17.	Illustration of the failure criterion based on plate deflections	19
18.	Breakthrough loads vs breakthrough time for a floating ice cover subjected to loads of long duration.....	21
19.	Limit stress distributions	23
20.	A comparison of P_f expressions with P_{cr} formula.....	24
21.	Temperature distributions in a floating ice plate for different times... ..	24

Figure	Page
22. Comparison of plate deflection curves based on bending and shear theories.....	26
23. Comparison of ice plate deflections due to loads of short duration at $-15^{\circ}\text{C} < T < -7^{\circ}\text{C}$	26
24. Comparison of ice plate deflections due to loads of short duration at 0°C	26
25. Laboratory test results for infinite plates.....	27
26. Illustration of new concept for evaluating breakthrough loads from test data	28
27. Results for semi-infinite plate.....	30
28. Cantilever test beam for the determination of σ_f	32

**THE BEARING CAPACITY OF FLOATING ICE PLATES
SUBJECTED TO STATIC OR QUASI-STATIC LOADS
A Critical Survey**

by

Arnold D. Kerr

INTRODUCTION

Frozen lakes and rivers have been utilized since early times for transportation and storage purposes. In Russia,^{1,25} in the absence of bridges, railroad tracks have been placed over frozen rivers since about 1890. Floating ice plates have been increasingly utilized as airfields for the landing of aircraft,^{1 81 86 128 135} as platforms for storage in logging operations,^{23 119} as platforms for the construction of river structures,^{84 143} as off-shore drilling platforms in the northern regions,²⁰ and as aids in various other civilian and military operations.* The successful defense of Leningrad during World War II was greatly facilitated by the "ice road" over Lake Ladoga.³⁸ The recent oil discoveries in northern Alaska have increased the interest in the arctic ice cover for off-shore drilling purposes. A rational utilization of floating ice plates for all these activities requires the knowledge of their bearing capacity when they are subjected to loads of short and long duration. Such information is also needed for the design of icebreakers.^{46 118}

Field observations reveal that when a vehicle is small and relatively heavy it may break through the ice plate immediately after placement. In such cases, the plate response may be considered elastic up until failure. For relatively light vehicles, the ice plate deforms elastically at the instant of loading, but sustains the load. However, as time progresses, the ice plate continues to deform in creep, especially in the vicinity of the vehicle, and after a certain time interval the vehicle may break through the ice.

In the past, numerous attempts have been made to determine the bearing capacity of floating ice plates subjected to vertical loads. Particularly, since World War II, many papers containing test data and related analyses have been published. However, in spite of these publications, there is as yet no reliable analytical method for predicting the bearing capacity of floating ice plates subjected to static or dynamic loads. This is particularly the case for floating ice plates reinforced by pressure ridges, a phenomenon often encountered in the Arctic,^{73 150} for which not even test data can be located in the literature.

One of the main reasons for the lack of reliable methods for determining the breakthrough loads of ice plates is the difficulties introduced by the fact that the lower surface of an ice plate is always subjected to the melting temperature of about 0°C, at which the mechanical properties of ice vary drastically with small changes of temperature. Other difficulties are the dependence of the mechanical properties of the ice plates upon the rate of freezing, the velocity of the

* Refs. 5, 17, 25, 40, 82, 120.

water below the plate during the freezing process, the salinity of the water, etc. Discussions of the mechanical properties of ice have recently been presented by Voitkovskii,¹⁴⁵ Weeks and Assur,^{148 149} Lavrov,⁷⁸ and Bogorodskii et al.¹⁰

Another main reason is the lack of effective communication among the various investigators, partly caused by the language barrier. This has resulted in the duplication of analyses and tests, often rendered useless by the same shortcomings. Also, the introduction of incorrect solutions for floating ice plates and their subsequent utilization for comparison with test data have not helped in solving the problems under consideration.

The purpose of this report is to present a critical survey of the literature on the bearing capacity of floating ice plates. First, the various analytical attempts to determine the bearing capacity are reviewed, grouped according to the used "failure criterion." This is followed by a discussion of test data and their relation to the analytical results. The report concludes with a systematic summary of results, a discussion of observed shortcomings, and recommendations for needed investigations. It is hoped that this survey and summary of results will establish a sense of direction in the investigations and will contribute toward developing methods for determining the bearing capacity of floating ice plates.

ANALOGY METHOD

The analogy method of predicting the bearing capacity of a floating ice plate subjected to a static vertical load, discussed by Korunov,^{68 69} is based on the notion of the analogy of two plates. Korunov assumed that the ice plates under consideration are homogeneous and isotropic and that for two plates with thicknesses h_1 and h_2 the corresponding failure moments M_1 and M_2 in cylindrical bending are

$$M_1 = \sigma_f \frac{h_1^2}{6} \tag{1}$$

$$M_2 = \sigma_f \frac{h_2^2}{6}$$

Assuming that the failure stress σ_f for the two plates is the same, it follows that

$$\frac{M_1}{M_2} = \frac{h_1^2}{h_2^2} \tag{2}$$

Considering the effect of two different loads, P_1 acting on the plate with thickness h_1 and P_2 acting on the plate with thickness h_2 , Korunov assumed that M is proportional to P , and obtained from eq 2

$$\frac{P_1}{P_2} = \frac{h_1^2}{h_2^2} \tag{3}$$

Equation 3 may be rewritten as follows

* Note that eq 3 was used, in 1938, by Moskatov (ref. 86, p. 51).

$$P_{\text{all}} = A h^2 \quad (4)$$

where $A = P_2 / h_2^2$. According to the above method, if an allowable load P_2 of an ice plate of thickness h_2 is known (from a test), then the allowable load P_{all} of an ice plate of different thickness may be computed if the σ_f values are the same for both plates. Thus, the coefficient A in eq 4 is to be determined from a specific test.

Some shortcomings in the derivation of eq 4 were discussed by Lagutin and Shulman.⁷⁶ It should also be noted that in a floating ice plate the bending stress distribution may not be linear across the plate thickness⁵⁵; therefore, eq 1 in the above derivations may not be admissible. Nevertheless, because of its extreme simplicity and its agreement with various test results, eq 4 found wide popularity, as shown in the following table (valid for P_{all} in metric tons and h in centimeters).

Source	Load	A
Korunov ⁶⁹ Peschanskii ¹¹⁵		0.01
Lebedev ⁷⁹ Zubov ¹⁵⁴		0.0166
Instructions of the Engineering Committee of the Red Army ⁴⁴	Wheeled vehicles	0.0070
	Tracked vehicles	0.0123
Lysukhin ⁸²	Wheeled vehicles	0.0082
	Tracked vehicles	0.0123

To demonstrate the use of eq 4 let us determine the necessary ice thickness for the crossing of a river by a truck weighing 36 metric tons, according to Korunov.⁶⁹ Using eq 4 the necessary ice thickness is

$$h = \sqrt{100} \sqrt{36} = 10 \times 6 = 60 \text{ cm.}$$

Additional examples of the use of eq 4 were presented by Moskatov,⁸⁶ Lysukhin⁸² and Gusev.⁸⁹

In order to take into consideration the effects of temperature, the dimensions of load distribution, and the salinity of ice, Zubov¹⁵⁴ modified eq 4 as follows:

$$P_{\text{all}} = K M s A h^2 \quad (5)$$

where K , M , and s are the corresponding correction coefficients. Discussions of this extension are presented in ref. 75 and 154.

Basing his work on field experience with fresh water ice, Korunov,⁷⁰ in 1956, modified eq 4 by introducing a correction coefficient n which takes into consideration the condition of the ice as follows:

$$P_{\text{all}} = \frac{1}{n} A h^2 \text{ in tons.} \quad (6)$$

In the above formula $A = 0.01$ and n is related to σ_f as follows:

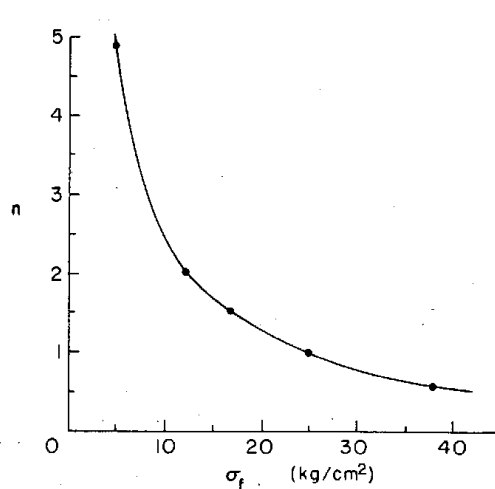

Figure 1. Correction coefficient n as related to failure stress σ_f (Korunov⁷⁰).

σ_f (kg/cm ²)	5	12	17	25	38
n	4.8	2.0	1.4	1.0	0.6

for $T < -7^\circ\text{C}$.

A graph of these values is given in Figure 1. This graph may be represented by the equation

$$n = \frac{25}{\sigma_f}$$

Substituting this into eq 6, we obtain for $T < -7^\circ\text{C}$

$$P_{\text{all}} = \frac{1}{2500} \sigma_f h^2 \quad \text{in tons}$$

$$P_{\text{all}} = 0.4 \sigma_f h^2 \quad \text{in kilograms.} \quad (7)$$

σ_f values were stipulated by Korunov⁷⁰ for five types of ice. Korunov⁷⁰ also introduced another correction coefficient for thaw temperatures.

METHOD BASED ON THE BENDING THEORY OF ELASTIC PLATES AND THE CRITERION $\sigma_{\text{max}} \approx \sigma_f$

This method of predicting the bearing capacity of a floating plate subjected to loads of short duration consists of the following three steps:

1. Determination of the maximum stress σ_{max} in the floating ice plate due to a given load, assuming that the ice plate is elastic.
2. Determination of the load at which the first crack occurs P_{cr} , utilizing the criterion

$$\sigma_{\text{max}} = \sigma_f. \quad (8)$$

3. Correlation of P_{cr} with the breakthrough load P_f . This step, disregarded by many investigators, is needed because, according to field tests, for various plate geometries, the occurrence of the first crack does not cause breakthrough; therefore, for these cases $P_f > P_{\text{cr}}$.

In the criterion in eq 8, σ_f is the "failure stress." It is usually obtained by loading a floating ice beam to failure and then computing the largest bending stress at which it failed. In the located literature, σ_{max} is determined using the classical bending theory of thin elastic plates. These results are reviewed in the following.

The response of a homogeneous and isotropic elastic plate that rests on a liquid and is subjected to a static vertical load q is described by the partial differential equation

$$D \nabla^4 w + \gamma w = q \quad (9)$$

where

- $w(x, y)$ = plate deflection at (x, y)
- D = flexural rigidity of the plate
- γ = specific weight of the liquid.

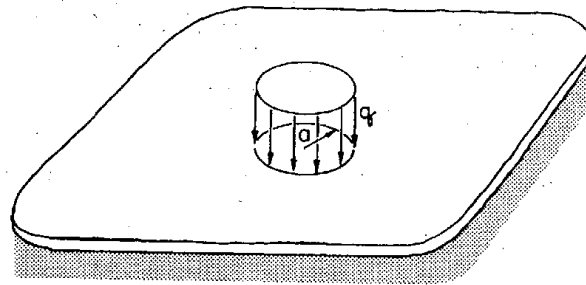

Figure 2. A floating ice plate subjected to a distributed load q over a circular area of radius a .

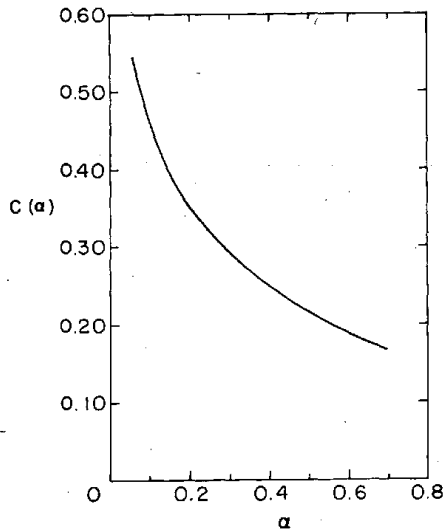

Figure 3. $C(\alpha)$ vs α graph.*

Solutions for the *infinite* plate subjected to a concentrated load P , and to a load uniformly distributed over a circular area, were presented by Hertz⁴¹ in 1884. In 1929 Bernshtein⁶ utilized this discussion for the determination of the allowable load for an infinite ice plate. Using the criterion in eq 8, in conjunction with the solution for an infinite plate subjected to a uniform load over a circular area, as shown in Figure 2, Bernshtein obtained

$$P_{cr} = \frac{1}{3(1+\nu)C(\alpha)} \sigma_f h^2 \quad (10a)$$

where

ν = Poisson's ratio for the plate material
 $C(\alpha)$ = a given function of $\alpha = a/\ell$, as shown in Figure 3

a = radius of the circular area subjected to the uniform load $q = P/\pi a^2$

$$\ell = \sqrt[3]{D/\gamma}$$

$$D = Eh^3/[12(1-\nu^2)].$$

If $\sigma_{max} = \sigma_f$ is a valid criterion, then P_{cr} is the load intensity at which the plate cracks.

To demonstrate the use of eq 10a, Bernshtein computed the σ_{max} due to a railroad car weighing 24 tons for a 70-cm-thick ice plate as follows (ref. 8, para. 20):

Assuming that $E = 550,000 \text{ t/m}^2$ and $\nu = 1/3$, he obtained

$$\ell = \sqrt[3]{\frac{D}{\gamma}} = 11.50 \text{ m.}$$

He then assumed that the effect of the weight of the railroad car may be represented by a load uniformly distributed over a circular area with radius $a = 1.54 \text{ m}$. Hence, $\alpha = a/\ell = 0.134$. From Figure 3, it follows that $C(\alpha) = 0.417$. For the above values eq 10a yields

$$\sigma_{max} = \frac{24,000 \times 3 \times \frac{4}{3} \times 0.417}{(70)^2} = 8.16 \text{ kg/cm}^2.$$

* This is a modified graph. In the original version,⁶ the $C(\alpha)$ presented is for P in tons, h in meters, and σ in kilograms per square centimeter.

The next step is to check whether $\sigma_{\max} \leq \sigma_f$. Additional numerical analyses are given in ref. 8. Other numerical examples, based on the Bernshtein solution, were presented by Volkov¹⁴⁶ in 1940 and by Bregman and Proskuriakov (ref. 11, part IV, section 7) in 1943.

The determination of the load P_{cr} for a *floating infinite plate* based on eq 9, the criterion in eq 8, and the assumption that the load $q = P/(\pi a^2)$ is distributed uniformly over a circular region of radius a was also presented by Wyman¹⁵³ in 1950, Kubo⁷⁵ in 1958, and Savel'ev¹²¹ in 1963. Wyman obtained for the load P_{cr} the equation

$$P_{cr} = \frac{\pi a}{3(1+\nu) \operatorname{kei}' a} \sigma_f h^2. \quad (10b)$$

This is identical to eq 10a, noting that

$$C(a) = \frac{\operatorname{kei}'(a)}{\pi a}. \quad (11)$$

The determination of P_{cr} , assuming that the uniform load is distributed over a square area with sides b , was obtained by Golushkevich³⁷ in 1944. The derived expression yields loads that are very close to those obtained from eq 10.

Solutions for an infinite plate were also presented by Schleicher¹²³ in 1926, Korenev⁶⁰ in 1954, Korenev⁶³ in 1960, and Korenev and Chernigovskaia⁶⁵ in 1962.

A solution for the infinite plate subjected to a row of equidistant loads was presented by Westergaard¹⁵¹ in 1923, in terms of a trigonometric series. Solutions to similar problems (periodic load distribution), also in terms of trigonometric series, were presented by Lewe⁸⁰ in 1923, Müller^{87 88} in 1952, and Panfilov^{100 105} in 1963 and 1964. Shekhter and Vinokurova¹²⁹ discussed related problems in 1936.

Since eq 9 is linear, it appears that when the plate is subjected to several loads, the method of superposition should be used. This idea was demonstrated by Kerr⁵⁰ in 1959 for the solution of the floating ice plate subjected to a row of equidistant loads. A major advantage of this approach is that the distribution of the loads on the floating plate may be arbitrary, whereas the use of trigonometric series is suitable only when the loads act along straight lines, all loads along a line are of the same intensity and distribution and the distance between them is the same.

The analysis of floating ice plates for arbitrary load distributions may be greatly simplified by utilizing influence surfaces.¹⁴² Charts of such surfaces were presented by Pickett and Ray¹¹⁶ in 1951 for concrete pavements. Influence surfaces for bending moments, more suitable for ice plate problems, were presented by Palmer⁹⁶ in 1971. Palmer's charts could also be used for the determination of load distributions on the plate that yield the largest possible bending moments. An attempt to solve such a problem without influence surfaces was made in 1965 by Nevel and Assur.⁹⁴ They considered the problem of the most unfavorable distribution of crowds on a floating ice plate from the point of view of bearing capacity, based on the criterion in eq 8. This problem was recently analyzed by Palmer⁹⁶ using influence surfaces.

Bernshtein's⁶ eq 10a is shown as the solid line in Figure 4. Shulman¹³² in 1946 simplified eq 10a by replacing the curve for $0.07 < a < 0.65$ with a straight line described by the expression

$$P_{cr} = 0.375 \sigma_f \left(h^2 + 7.8a \sqrt{\frac{Y}{E}} h^{5/4} \right) \quad (12a)$$

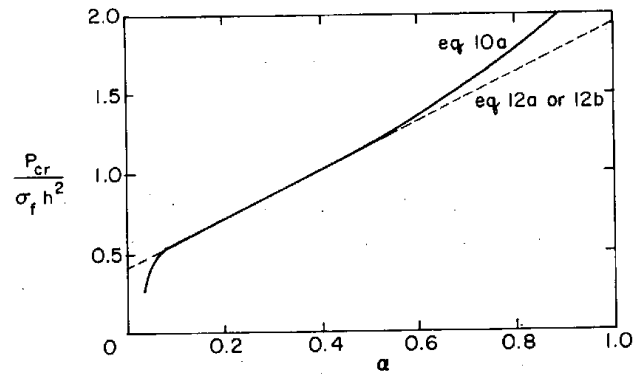

Figure 4. $P_{cr}/\sigma_f h^2$ vs α .

Panfilov⁹⁷ in 1960 proposed the expression

$$P_{cr} = 0.375(1 + 4.1\alpha)\sigma_f h^2 \quad (12b)$$

based on the idea of a straight-line approximation. Panfilov's approximation (eq 12b) is the same as the one presented by Shulman,¹³² since for $\nu = 0.3$

$$4.1 \frac{a}{l} h^2 = 4.1 \frac{a \sqrt{12(1-\nu^2)\gamma} h^2}{\sqrt{Eh^3}} \equiv 7.4a \sqrt{\frac{\gamma}{E}} h^{5/4}. \quad (13)$$

Panfilov⁹⁷ also proposed the following approximation:

$$P_{cr} = \frac{2\pi}{3(1+\nu)(0.682 + 0.019\alpha^2 - \ln \alpha)} \sigma_f h^2. \quad (14)$$

However, since this is not much simpler than the exact expression (eq 10a or 10b), its usefulness is questionable.

In 1964, Panfilov¹⁰⁴ attempted to derive another approximate expression for P_{cr} , assuming that the deflections of a floating ice plate subjected to a concentrated force P may be expressed approximately as follows:

$$w(x, y) = w_0 \exp\left[-\frac{\lambda}{\sqrt{2}}(x+y)\right] \left(\sin \frac{\lambda x}{\sqrt{2}} + \cos \frac{\lambda x}{\sqrt{2}}\right) \left(\sin \frac{\lambda y}{\sqrt{2}} + \cos \frac{\lambda y}{\sqrt{2}}\right) \quad (15)$$

where

$$\lambda = \sqrt[3]{\gamma/D}. \quad (16)$$

From the equilibrium equation

$$P = 4\gamma \int_0^\infty \int_0^\infty w \, dx \, dy. \quad (17)$$

Panfilov determined the only unknown, w_0 , as

$$w_0 = \frac{P}{8\sqrt{\gamma D}}. \quad (18)$$

Comparing the resulting $w(x, y)$ with the exact solution, and finding that the agreement was relatively close, Panfilov determined the bending moments, using the relations (ref. 142, p. 81)

$$M_x(x, y) = -D \left(\frac{\partial^2 w}{\partial x^2} + \nu \frac{\partial^2 w}{\partial y^2} \right) \quad (19)$$

$$M_y(x, y) = -D \left(\frac{\partial^2 w}{\partial y^2} + \nu \frac{\partial^2 w}{\partial x^2} \right)$$

and the approximate $w(x, y)$ given in eq 15. For the bending moments under the load P , he obtained

$$M_x(0, 0) = M_y(0, 0) = \frac{(1 + \nu)P}{8}. \quad (20)$$

Equating this expression with $M_{cr} = \sigma_f h^2 / 6$, Panfilov obtained for $\nu = \frac{1}{2}$ the expression

$$P_{cr} = \sigma_f h^2. \quad (21)$$

At this point, note that the relative closeness of the approximate and exact deflections (in the sense of comparing two graphs) does not imply that the second derivatives are also close. Thus, for example, whereas the exact solution for the classical plate theory (used by Panfilov) yields infinite moments under the concentrated load P ,* Panfilov's approximate solution yields the finite value shown in eq 20. This point may be demonstrated further by comparing the graphs for the bending moment $M_x(x, 0)$ based on eq 15 and on the exact solution. It may be shown that, although the deflections are relatively close, the bending moments based on eq 15 do not approximate closely the actual bending moments, especially in the vicinity of the load.

Other approximate solutions for the infinite plate were discussed by Korunov⁷¹ in 1967. Assuming that Bernshtein's⁸ eq 10a is the correct expression for predicting the bearing capacity, Korunov proposed the empirical expression (for h in centimeters).

$$P_{cr} = \frac{6}{100} ah^2 \quad \text{in tons}$$

or rewritten

$$P_{cr} = 60ah^2 \quad \text{in kilograms} \quad (22)$$

and then showed that for special situations, it agrees with the results of eq 10a. Noting that eq 22 is based on $\sigma_f = 24 \text{ kg/cm}^2$, it follows that

* To determine the stresses under the load, the correction derived by Westergaard (ref. 142, p. 275) may be used.

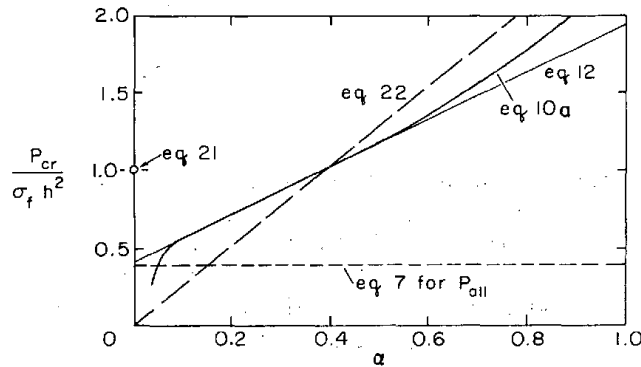

Figure 5. A comparison of approximations for P_{cr} with exact graph.

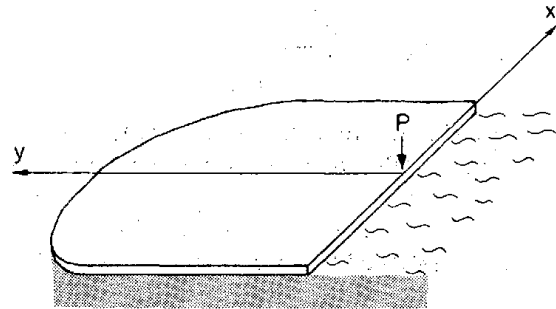

Figure 6. Semi-infinite plate with free edge subjected to load P .

$$\frac{P_{cr}}{\sigma_f h^2} = 2.5 \alpha.$$

Note that, according to eq 22, for a given σ_f , P_{cr} is proportional to the second term in eq 12a or 12b, h^4 , whereas eq 21, derived for $\alpha = 0$, is proportional to the first term, h^2 . Note also the difference between eq 7, suggested by Korunov, and eq 21, derived by Panfilov. A comparison of various approximate expressions for P_{cr} with the one based on eq 10a is shown in Figure 5.

It appears that, instead of deriving numerous approximate expressions for eq 10 that differ substantially from each other and are not much simpler than the exact expression,* first it must be established whether eq 10 is suitable for predicting the bearing capacity of floating ice plates for loads of short duration. This and related questions will be discussed later.

Solutions for the *floating semi-infinite plate with a free edge* subjected to lateral loads were presented by Westergaard¹⁵¹ in 1923, Shapiro¹²⁷ in 1943, and Golushkevich³⁷ in 1944, using Fourier integral methods. Shapiro's results were verified and extended by Nevel⁹² in 1965.

In 1950, Zylev,¹⁵⁷ using the criterion in eq 8 presented calculations of the bearing capacity of a floating semi-infinite ice plate subjected along its free edge to vertical and horizontal loads. However, Zylev's approximate solution of eq 9 for the vertical load, recently included in a number of publications,^{14 66} is incorrect, as shown below.

For the semi-infinite plate shown in Figure 6, Zylev¹⁵⁷ assumed an approximate solution of the form

$$w(x, y) = [\cosh(\alpha x) + \Gamma \sinh(\alpha x)]f(y) \tag{23}$$

where

$$\begin{aligned} \Gamma &= 1 & \text{for } x < 0 \\ \Gamma &= -1 & \text{for } x > 0. \end{aligned} \tag{24}$$

Substituting eq 23 into differential eq 9 with $q = 0$, he obtained an ordinary differential equation of fourth order for $f(y)$. To determine the four constants, he used two regularity conditions at infinity and the conditions

* A prospective user of eq 10 does not have to be familiar with Bessel functions if he utilizes the $C(\alpha)$ vs α graph shown in Figure 3.

$$M_y(x, 0) = 0 \quad (25)$$

$$P = \int_0^{\infty} dy \int_{-\infty}^{\infty} \gamma w dx. \quad (26)$$

Note that, for the chosen deflection surface (eq 23), $\partial w / \partial x$ is discontinuous along the y -axis, which is not the case in an actual plate. The quantity $\partial^3 w / \partial x^3$ is also discontinuous along the y -axis; this implies that for the assumed deflection surface there exists a line load along the y -axis. This is in contradiction to the assumed plate load shown in Figure 6. Furthermore, along the free edge, where the largest stresses are anticipated, the boundary conditions for a free edge are not satisfied. Therefore, the validity of Zylev's solution for the semi-infinite plate, even for the determination of an approximate P_{cr} , is questionable.

According to Zylev's¹⁵⁷ results, the largest bending moment takes place at the point $x = 0$ and $y = 1.14 \sqrt[4]{D}$. On the basis of this analysis

$$P_{cr} = 0.8\lambda(1 - e^{-\lambda})^{-1} \sigma_f h^2 \quad (27)$$

where

$$\lambda = \frac{0.248b}{\sqrt[4]{D}}. \quad (28)$$

According to Shapiro's results, σ_{max} takes place under the load. Utilizing criterion in eq 8, the load at which the first crack occurs becomes

$$P_{cr} = S(\alpha)\sigma_f h^2 \quad (29)$$

where $S(\alpha)$ for $\nu = 0.36$ is given in Figure 7.

In 1960, Panfilov⁹⁸ compared the values of the load P_{cr} for the infinite plate as well as the semi-infinite plate. The corresponding graphs are shown in Figure 7. This comparison shows that P_{cr} for the semi-infinite plate, according to Zylev¹⁵⁷ (dashed line), is much higher than P_{cr} according to Shapiro¹²⁷ and Golushkevich.³⁷ In $0 < b/l < 0.5$, it is even higher than the P_{cr} of the infinite plate. In view of this comparison and the obvious errors contained in Zylev's solution, it is suggested that eq 27 should not be used for the analysis of the semi-infinite plate with a free edge.

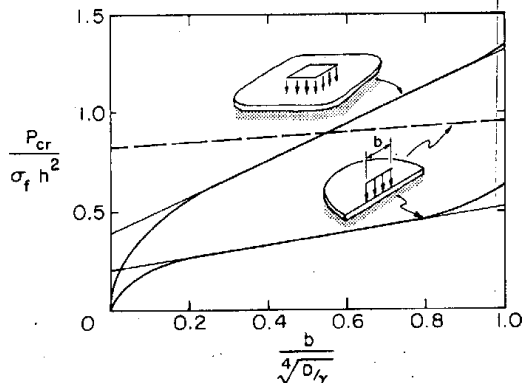

Figure 7. Comparison of analytical results.⁹⁸

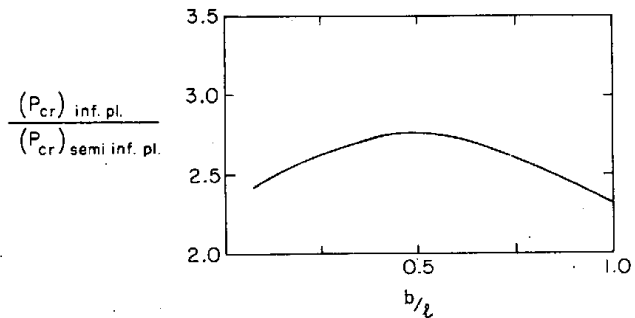

Figure 8. $(P_{cr})_{inf pl} / (P_{cr})_{semi inf pl}$ vs b/l .

According to Panfilov,⁹⁸ it follows from Figure 7 that for $0.07 < b/\ell < 1.0$

$$(P_{cr})_{inf\ pl} \cong 2.45(P_{cr})_{semi-inf\ pl}$$

A more precise relationship is shown in Figure 8.

On the basis of the graph for the semi-infinite plate shown in Figure 7, Panfilov⁹⁸ proposed for the interval $0.07 < b/\ell < 1$ the following approximate expression:

$$P_{cr} = 0.16 \left(1 + 2.30 \frac{b}{\ell} \right) \sigma_f h^2. \quad (30)$$

Panfilov¹⁰⁴ attempted to derive an approximate expression for P_{cr} for the problem shown in Figure 6, assuming that

$$w(x, y) = w_0 \exp \left[-\frac{\lambda}{\sqrt{2}}(x+y) \right] \left(\sin \frac{\lambda x}{\sqrt{2}} + \cos \frac{\lambda x}{\sqrt{2}} \right) \cos \frac{\lambda y}{\sqrt{2}}. \quad (31)$$

However, the result obtained, similar in form to eq 21, is of questionable value. The objections raised in connection with eq 21 also apply here. Note that the deflection surface (eq 31) does not satisfy the differential eq 9 or the boundary conditions along the free edge, where the stresses are determined for comparison with criterion in eq 8.

The semi-infinite plate subjected to equidistant loads P along the free edge was analyzed by Westergaard¹⁵¹ in 1923. Similar problems were solved by Panfilov¹⁰¹⁻¹⁰³ in 1963. The publications of Shekhter and Vinokurova,¹²⁹ and Korenev and Chernigovskaia⁶⁵ also contain solutions to related problems.

The solution for the *semi-infinite plate, simply supported* along the straight edge and subjected at any point of the plate to a concentrated force P , as shown in Figure 9, was derived by Kerr⁵⁰ in 1959. Using the method of images, the following exact closed form solution was obtained:

$$w(x, y) = \frac{P \lambda^2}{2\pi k} \left\{ \text{kei} \left[\lambda \sqrt{(x-x_0)^2 + y^2} \right] - \text{kei} \left[\lambda \sqrt{(x+x_0)^2 + y^2} \right] \right\}. \quad (32)$$

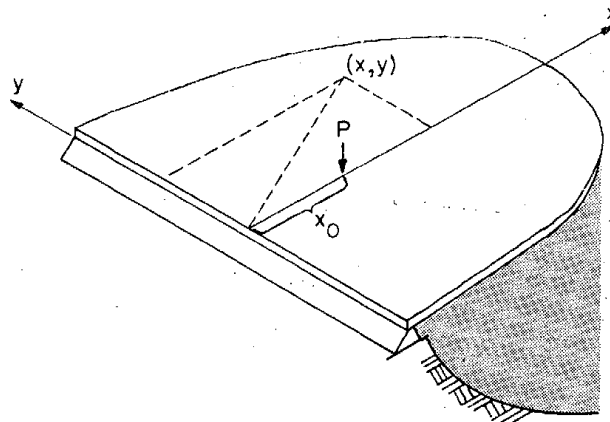

Figure 9. Semi-infinite floating plate, simply supported along the straight edge and subjected to a load P.

In 1971, Palmer⁹⁶ utilized this solution to construct a number of influence surfaces for bending moments.

A numerical solution for the *semi-infinite plate, clamped* along the edge and subjected to a force P at a point on the plate, was presented by Korenev⁹⁷ in 1960.

An analysis of a *floating infinite strip, free* along both edges and subjected to a lateral load, was presented by Shapiro¹²⁶ in 1942, utilizing the Fourier integral method. Detailed results for similar problems were presented by Panfilov^{108, 109} in 1966 and 1970.

The solution for a *floating infinite strip, simply supported* along both edges and subjected to a concentrated force P at any point on the plate, was presented by Kerr⁹⁰ in 1959, utilizing the method of images. The resulting deflection was given as a rapidly converging infinite series of fundamental solutions for the infinite plate. Other solutions for this problem were presented by Westergaard¹⁵¹ in 1923, in terms of Fourier series and by Nevel⁹² in 1965 in terms of a Fourier integral. A solution for a similar problem was presented by Panfilov¹⁰⁸ in 1966, also using the Fourier integral method.

The *infinite strip, with clamped* boundaries, was analyzed by Nevel⁹² in 1965 and by Panfilov¹⁰⁸ in 1966, using Fourier integral methods.

In 1960, Kashtelian⁴⁸ presented calculations for the direct determination of P_f [that is, by eliminating step 3 (p. 4) in the above procedure] that are based on the observation that the carrying capacity is reached when the wedges, which form initially, break off. However, Kashtelian's solution for the wedge-shaped plate, on which his calculations are based, is incorrect, as shown in the following.

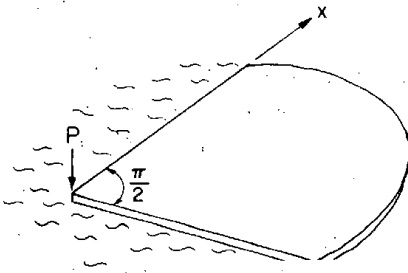

Figure 10. A floating rectangular corner plate with free edges subjected to load P at the corner.

For the *rectangular corner plate with free edges*, shown in Figure 10, Kashtelian assumed an approximate solution

$$w(x, y) = f \exp[-a(x+y)] \cos(ax) \cos(ay) \quad (33)$$

where a and f are unknown parameters. From the condition

$$P = \int_0^{\infty} \int_0^{\infty} \gamma w \, dx dy \quad (34)$$

Kashtelian obtained

$$f = \frac{4a^2 P}{\gamma} \quad (35)$$

Then, utilizing the Bubnov-Galerkin method, for a one-term approximation he used

$$\int_0^{\infty} \int_0^{\infty} \left(\nabla^4 w + \frac{\gamma w}{D} \right) w \, dx dy = 0 \quad (36)$$

and determined from it

$$a = \sqrt{\frac{\gamma}{4D}} \quad (37)$$

Thus, according to eq 35

$$f = \frac{2P}{\sqrt{\gamma D}} \quad (38)$$

It should be noted that the above analysis contains an error; namely, because the assumed deflection expression (eq 33) does not satisfy the boundary conditions of zero moments and zero shearing forces along the free boundary, eq 36 is not complete. According to the principle of virtual displacements, the proper Bubnov-Galerkin equation for a one-term approximation $w = fw_1(x, y)$ is

$$\begin{aligned} & \int_0^{\infty} \int_0^{\infty} (D\nabla^4 w + kw)w_1 dx dy + \int_0^{\infty} M_y(x, 0)w_{1,y}(x, 0)dx - \int_0^{\infty} V_y(x, 0)w_1(x, 0)dx + \\ & + \int_0^{\infty} M_x(0, y)w_{1,x}(0, y)dy - \int_0^{\infty} V_x(0, y)w_1(0, y)dy - Pw_1(0, 0) = 0 \end{aligned} \quad (39)$$

where M_x and M_y are given in eq 19 and

$$V_x(0, y) = -D[w_{,xxx} + (2-\nu)w_{,xyy}]_{x=0} \quad (40)$$

$$V_y(x, 0) = -D[w_{,yyy} + (2-\nu)w_{,xxy}]_{y=0}$$

Comparing the f value given in eq 38 with the corresponding values of the exact solution of an infinite plate, $f = P/(8\sqrt{\gamma D})$, and the (incorrect) approximate solution by Zylev¹⁵⁷ for a semi-infinite plate, $f = P/(2\sqrt{\gamma D})$, Kashtelian,⁴⁸ without justification, generalized his solution for the rectangular corner plate to a solution for a wedge of any opening angle ϕ (Fig. 11) by assuming that

$$f = \frac{1}{2} \left(\frac{\pi}{\phi} \right)^2 \frac{P}{\sqrt{\gamma D}} \quad (41)$$

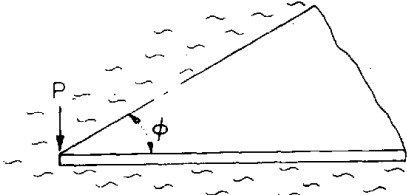

Figure 11. Floating wedge shaped plate of opening angle ϕ subjected to load P at the tip.

an equation which satisfies eq 38 for $\phi = \pi/2$ and the other two cases ($\phi = 2\pi$ and $\phi = \pi$) mentioned above. Utilizing criterion in eq 8, he then obtained for the "failure load" of a floating wedge plate of opening angle ϕ the expression

$$P_f = \left(\frac{\phi}{\pi} \right)^2 \frac{1}{0.966} \sigma_f h^2 \quad (42)$$

Note that, according to field observations,⁴⁸ when $\phi < 120^\circ$, $P_{cr} = P_f$. Thus, according to eq 42, for a floating wedge with $\phi = \pi/2$, as shown in Figure 10, the breakthrough load is

$$P_f = \left(\frac{1}{2} \right)^2 \frac{\sigma_f h^2}{0.966} = 0.259 \sigma_f h^2.$$

Observations in the field indicate that the failure mechanism of a semi-infinite plate subjected to a force P at the free edge proceeds as follows. First, a radial crack forms, which starts under the

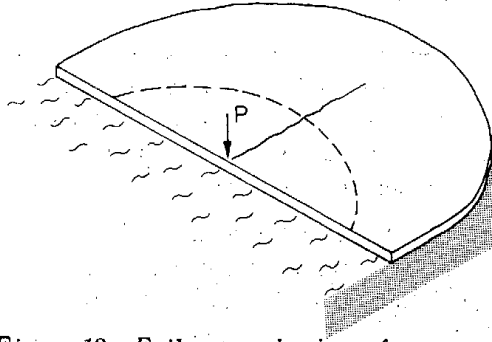

Figure 12. Failure mechanism of a floating semi-infinite plate subjected along the free edge to a load P .

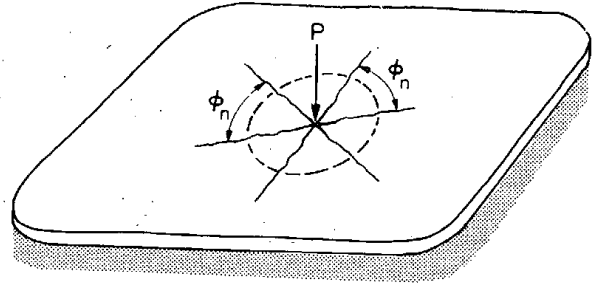

Figure 13. Failure mechanism for a large floating plate subjected to a load P .

load and propagates normal to the free boundary. This is followed by the formation of a circumferential crack that causes final failure, as shown in Figure 12. According to Kashtelian,⁴⁸ the failure load for this case is equal to the failure load of two free floating wedges, each of opening angle $\phi = \pi/2$:

$$P_f = 2 \times 0.259 \sigma_f h^2 = 0.518 \sigma_f h^2. \quad (43)$$

In a similar way, Kashtelian⁴⁸ determined the P_f for an *infinite plate*. Assuming that n is the number of radial cracks and that the n formed wedges are all of equal opening angle, i.e., $\phi_n = 2\pi/n$, as shown in Figure 13, the following expression for the failure load results:

$$P_f = n \left(\frac{2\pi}{n} \frac{1}{\pi} \right)^2 \frac{\sigma_f h^2}{0.966} = \frac{4}{n \times 0.966} \sigma_f h^2.$$

Noting that $n = 2\pi/\phi_n$, this expression may also be written as

$$P_f = 2.08 \left(\frac{\phi_n}{\pi} \right)^2 \sigma_f h^2 \quad (44)$$

where ϕ_n is the opening angle of the formed wedges. Note that, with decreasing ϕ_n , the load P_f in eq 44 decreases and that the above approach does not take into consideration the effect of the wedge-in moments along the cracks.

Kashtelian showed that the results of 150 tests on floating ice plates agree closely with the bearing capacity values based on eq 43 and 44. In view of the errors discussed above, however, this agreement is not convincing.

An approximate solution for the *quarter plate with free edges* loaded at the apex was also presented by Westergaard¹⁵² in 1948.

An exact close form solution for the *quarter plate simply supported* along the edges and subjected at any point of the plate to a concentrated force P was presented by Kerr⁵⁰ in 1959, using the method of images.

The response of a *narrow infinite wedge* resting on a liquid base, as a beam problem, is described by an ordinary differential equation with a variable coefficient. This equation was solved by Dieudonee²¹ in 1957 by means of the Laplace method of integration. Nevel⁸⁹ in 1958 solved it

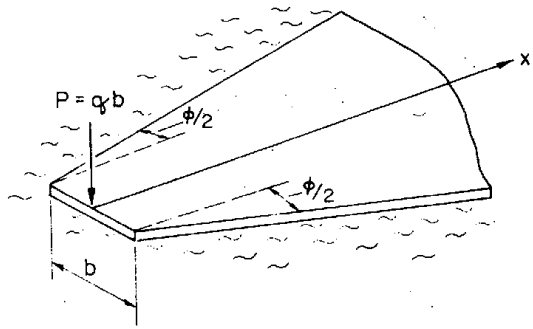

Figure 14. Wedge shaped plate subjected to a load $P = qb$.

using the method of Frobenius. Nevel's solution consisted of a sum of four infinite series which were evaluated and are presented as graphs in ref. 90. An approximate solution for large values of x , was presented by Hetényi.⁴²

An early attempt to determine the carrying capacity of a floating ice plate, utilizing a floating wedge solution, was described by Papkovich¹¹² in 1945. In this analysis it was assumed that the wedge response is governed by a modified bending theory of beams (Fig. 14) by stating the base parameter as

$$K(x) = \gamma \left(b + 2x \operatorname{tg} \frac{\phi}{2} \right) \quad (45)$$

and the flexural rigidity EI as

$$EI(x) = \frac{Eh^3}{12(1-\nu^2)} \left(b + 2x \operatorname{tg} \frac{\phi}{2} \right) \quad (46)$$

where γ is the specific weight of the liquid. The term $(1 - \nu^2)$ was apparently included to get plate action for the wedge. The deflection was assumed in the form

$$w(x) = A e^{-\lambda x} \cos(\lambda x) \quad (47)$$

where

$$\lambda = \sqrt[4]{\frac{k(x)}{4EI(x)}} = \sqrt[4]{\frac{3\gamma(1-\nu^2)}{Eh^3}} \quad (48)$$

and the unknown constant A was determined by minimizing the total potential energy. Substituting the determined

$$A = \frac{2\lambda^2 P}{\gamma \left[\lambda b + \operatorname{tg} \left(\frac{\phi}{2} \right) \right]} \quad (49)$$

into eq 47 yields the deflection

$$w(x) = \frac{2\lambda^2 P}{\gamma \left[\lambda b + \operatorname{tg} \left(\frac{\phi}{2} \right) \right]} e^{-\lambda x} \cos(\lambda x). \quad (50)$$

The bending moment is

$$M(x) = -EI \frac{d^2 w}{dx^2} = -EI(x) 2A \lambda^2 e^{-\lambda x} \cos(\lambda x)$$

and the stresses in the upper and lower fibers were obtained as

$$\sigma(x) = \pm \frac{M(x)}{W(x)} = \pm \frac{Eh}{1-\nu^2} A \lambda^2 e^{-\lambda x} \cos(\lambda x).$$

From the condition $d\sigma/dx = 0$, the position of the largest stress, $x = \pi/(4\lambda)$, was determined. Substituting this value into the above equation, it follows that

$$\sigma_{\max} = \frac{0.15}{1-\nu^2} A \lambda^2 E h. \quad (51)$$

Utilizing the failure criterion in eq 8, $\sigma_{\max} = \sigma_f$, it follows from eq 51, using eq 48 and 49, that

$$P_f = \frac{(\lambda b + tg \frac{\phi}{2})}{0.9} \sigma_f h^2. \quad (52)$$

Noting eq 48, the above expression for the failure load of a wedge of opening angle ϕ may also be written as

$$P_f = \left\{ \left[\frac{b}{0.9} \sqrt{3(1-\nu^2)} \sqrt{\frac{Y}{E}} \right] h^{5/4} + \left[\frac{tg \frac{\phi}{2}}{0.9} \right] h^2 \right\} \sigma_f. \quad (53)$$

Pointing out that an ice plate breaks up under the weight of an icebreaker into wedges and that P_f in eq 53 is of the form

$$P_f = A_1 h^2 + A_2 h^{5/4} \quad (54)$$

Papkovich suggested that eq 54 be utilized for the determination of an empirical expression for the breakthrough load of an ice plate by determining the parameters A_1 and A_2 from field test data.

Although eq 53 is only an approximation (for example, the corresponding bending moment at $x = 0$ is $\neq 0$), its dependence upon h is identical with that of expressions in eq 12a and 12b for the infinite plate and eq 30 for the semi-infinite plate, respectively. Even the term $b\sqrt{Y/E}$ appears in the proper place. This observation will be of importance in the discussion of test data presented in ref. 98.

For solutions to other plate problems, whose response is governed by differential eq 9, reference is made to the books by Schleicher,¹²³ Shekhter and Vinokurova,¹²⁹ Korenev,^{60, 63} and Korenev and Chernigovskaia⁶⁵; to the survey articles by Korenev^{62, 64} and Savel'ev¹²²; and to the literature on the analysis of highway and airport pavements.

When a floating ice plate seals the liquid base, in addition to the buoyancy pressure $kw(x, y)$, the liquid exerts a uniform pressure p^* on the plate. In such cases, an additional condition has to be imposed on the solution to reflect this situation. The unknown p^* is determined from this condition.

If the assumption that the liquid is sealed and incompressible is justified, then this additional condition is

$$\iint_A w dA = 0 \quad (55)$$

where the integration extends over the domain of the plate A .

Floating plates subjected to condition expressed in eq 55 were analyzed by Kerr^{52, 53} and Nevel.⁹¹ Kerr and Becker⁵⁴ solved plate problems by assuming that the sealed liquid is compressible. They showed that the effect of the sealed liquid depends not only upon its relative compressibility but also upon the sealed volume: the larger the sealed volume, the smaller the sealability effect. This result suggests that the use of eq 55 for the analysis of an ice plate that covers a river or a lake, as suggested recently by Mahrenholtz,⁴³ is not justified.

The analyses reviewed in this section are based on eq 9, the differential equation for a homogeneous and isotropic thin elastic plate. In an actual floating ice plate, the material parameters vary across the thickness of the plate; hence, the floating ice plate is nonhomogeneous. This variation is very pronounced in sea ice plates as well as in a plate whose upper surface is subjected to very low air temperatures.

An early attempt to take into consideration the variation of Young's modulus E (ref. 11, p. 73) is incorrect because the investigators did not take into consideration that when E varies across the plate thickness the resulting stress distribution is not linear.

According to recent analyses by Newman and Forray,⁹⁵ Assur,⁴ and Panfilov,¹⁰⁷ when Young's modulus E varies with the plate thickness h , and Poisson's ratio ν is assumed to be constant, eq 9 is still valid if the flexural rigidity is

$$D = \frac{1}{1 - \nu^2} \int_{-z_0}^{h - z_0} z^2 E(z) dz \quad (56)$$

and the position of the reference plane is determined from the condition

$$\int_{-z_0}^{h - z_0} z E(z) dz = 0. \quad (57)$$

For the utilization of the available solutions of eq 9 also for nonhomogeneous plates with $E = E(z)$, it had to be shown that, except for eq 56, the corresponding boundary conditions are the same as those for homogeneous plates. This was done recently by Kerr and Palmer,⁵⁵ who systematically formulated this problem utilizing Hamilton's principle in conjunction with the three dimensional theory of elasticity. Kerr and Palmer⁵⁵ also showed that even though the plane section hypothesis is assumed, the resulting bending stress distributions are *not* linear across the plate thickness. An example is given in Figure 15. This finding suggests that the well known stress equation

$$\sigma_{\max} = \frac{6M_{\max}}{h^2}$$

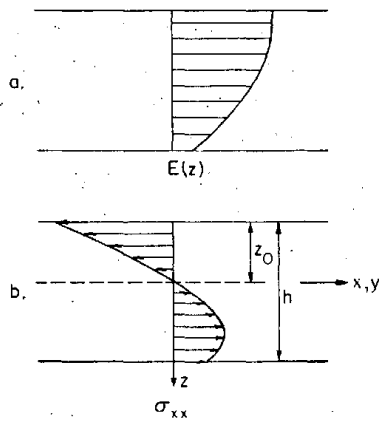

Figure 15. Stress distribution in the plate for a given $E(z)$.

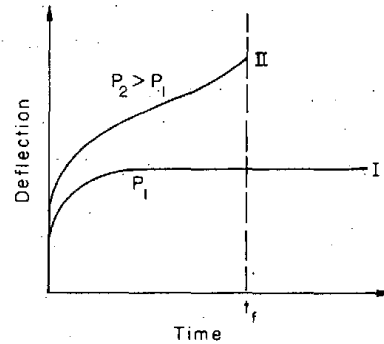

Figure 16. Deflection vs time curves for a floating ice plate and fixed loads.

utilized by various investigators in conjunction with the criterion in eq 8, or for the determination of the failure stress σ_f from tests on floating ice beams, may not be applicable in general.

It should be noted that highly concentrated loads often cause punch-through failures; for such situations, that is, for very small α , the above methods may not be suitable and a different approach may have to be utilized to determine the breakthrough load.

METHOD BASED ON VISCOELASTIC THEORIES

It was observed in the field that for loads that do not cause an instantaneous breakthrough the ice plate deforms at first elastically and then, with progressing time, continues to deform in creep, especially in the vicinity of the load. Two characteristic deflection-vs-time curves for fixed loads P are shown in Figure 16. Curve I represents the case when, after a time, the rates of deformation diminish and the ice plate and load come to a standstill. This curve corresponds to a safe load for any length of time under consideration. Curve II represents the case when, after a time, the rates of deformation increase and at time t_f the load breaks through. Thus, the load that corresponds to curve II is safe for time $t < t_f$, but then it has to be moved to another location to prevent breakthrough. The above field observations suggest that for an analytical determination of breakthrough loads which do not cause immediate failure a viscoelastic analysis must be conducted.

It appears that the small deformation theory of plates may be sufficient for plates which follow curve I. However, the analysis of plates which respond according to curve II is more complicated because in the vicinity of the load, a region of prime interest, the small deflection theory may not be valid for t approaching t_f . Also, as the plate deflections increase, the plate may start to crack – a phenomenon not predicted by the usual theories of viscoelastic continua. To predict cracking, a separate failure or crack criterion must be used. Also, after the first crack takes place the analysis gets even more involved because of the introduction of additional, often irregular, plate boundaries.

For an analytical determination of a "safe" load $P < P_f$ and a "time to failure" t_f , it is desirable to have one viscoelastic theory for floating ice plates which for time $t = 0$ yield the elastic response and for $t > 0$ yield responses according to curve I or II, depending upon the load and the

material parameters of the ice (which in turn depend upon the temperature distribution, salinity, etc.). This theory should be supplemented by a crack or failure criterion valid for the elastic and viscoelastic range. The elastic theory in conjunction with the crack criterion $\sigma_{\max} = \sigma_f$ discussed above could, if proven correct, be a special case of such a general theory.

Another failure criterion was proposed by Zubov⁵⁴ in 1942 and by Kobeko et al.⁵⁹ in 1946. On the basis of their test data, they concluded that for loads of short or long duration, a floating ice plate fails under the load when a certain deflection w_f is reached; that is, when

$$w_{\max} = w_f \tag{58}$$

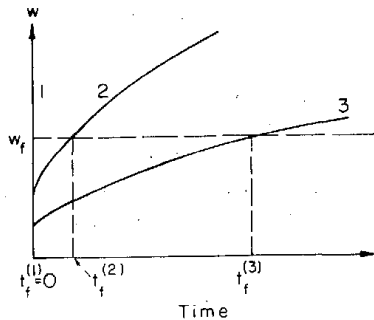

Figure 17. Illustration of the failure criterion based on plate deflections.

According to Kobeko et al.,⁵⁹ for this criterion it does not matter whether the plate deflections are purely elastic or viscoelastic, as shown in Figure 17. The criterion in eq 58 was also adopted by Savel'ev (ref. 121, p. 438) in 1963 for the study of the effect of temperature and salinity on the carrying capacity of a floating ice cover.

In 1961, Panfilov⁹⁹ proposed the above criterion for floating ice plates that are cracked in the dished area. His justification was that in the dished area water begins to flood the upper surface of the plate, with a resulting loss of base pressure in this area. It may be added that the flooding of the upper surface near the load also raises the temperature of the upper layers of the plate to about 0°C, thus decreasing the strength of the ice in the area of high stresses.

From experiments on floating ice plates, with plate thicknesses h from 1 to 6 cm and temperatures from -3°C to -8.5°C, Panfilov⁹⁹ found that

$$w_f = 2.2\sqrt{h} \tag{59}$$

where w_f and h are given in centimeters. In this connection it is of interest to note that, using criterion $w_{\max} = w_f$ in conjunction with eq 59 and the solution for an infinite (uncracked) elastic plate subjected to a concentrated load P

$$w_{\max} = w(0, 0) = \frac{P}{8\sqrt{\gamma D}}$$

it follows that

$$\frac{P_f}{8\sqrt{\gamma D}} = 2.2\sqrt{h}$$

or

$$P_f = \left[17.6 \sqrt{\frac{\gamma E}{12(1-\nu^2)}} \right] h^2 \tag{60}$$

Thus, according to the criterion in eq 59, the breakthrough load P_f is proportional to h^2 . It may also be of interest to note that if the largest deflection of the plate under consideration is expressed by the equation

$$w_{\max} = \frac{\epsilon P}{\sqrt{\gamma D}}$$

where ϵ is a coefficient, then a P_f expression of the form shown in eq 54 corresponds to the criterion

$$w_f = \alpha\sqrt{h} + \frac{\beta}{\sqrt{h}} \quad (61)$$

where α and β are coefficients.

Test data are needed to establish whether the failure criterion in eq 58 and its special forms in eq 59 or 61 are indeed valid for elastic as well as viscoelastic deformations.

In the early attempts to take time effects into consideration for floating ice plates, one approach utilized the solutions for elastic bending and tried to fit the experimental data by modifying the elastic constants (ref. 11, p. 53). In another approach, the elastic results were multiplied by a time factor $(1 + at^\beta)$, where t is time and α and β are constants to be determined from experimental data (ref. 6, eq 177). However, these approaches have no rational foundation and their results are of questionable value.

Another early approach was based on Zubov's hypothesis, which states that deflections of ice plates, especially at comparatively high temperatures, are caused mainly by vertical shearing forces (ref. 154, p. 49). To verify Zubov's assumption, Zvolinskii¹⁵⁶ analyzed a plate resting on a liquid, assuming that the deformations are entirely due to shearing action and that for creep deformations the material obeys Newton's law of viscosity. Although the resulting differential equation was relatively simple, because of the prescribed initial conditions the obtained solution was rather involved: Zvolinskii (ref. 156, p. 21) stated: "In this formula the result is not self evident, and analyzing it does not help us to visualize the picture of the phenomenon."

Zvolinskii used, for the initial condition, the elastic deflection surface caused by shear only. However, according to some experiments, shortly after the load is placed the deflection surface agrees closely with the elastic deflection surface due to bending (ref. 8, Fig. 18). Also, since the elastic deflections are relatively small, the effect of assuming that the elastic deformations are zero seems to be negligible compared with the introduced error of assuming shear as the only force responsible for creep deformations. This assumption was made by Kerr,⁴⁹ who attempted to simplify Zvolinskii's analysis in order to study the characteristic features of the creep deformations based on Zubov's¹⁵⁴ hypothesis.

Recorded observations of the effect of static loads on the deformation of floating ice fields showed (Fig. 16) that in some cases the rates of deflection decreased after the load was placed and after a certain time interval the plate came to a standstill (ref. 8, p. 48; ref. 154, p. 146), whereas in other cases the rates of deflection increased until the plate collapsed under the load. The observed decreasing and increasing rates of deflection should result from a general formulation of the problem. However, because of the simplifying assumptions made, it was necessary⁴⁹ to incorporate it by setting up two separate formulations for the decreasing and increasing rates of deformation. Although some of the results obtained did agree with deflection expressions given by Zubov (ref. 154, p. 24; ref. 155, p. 148), because of the various assumptions made, the resulting analysis is not conclusive for the determination of breakthrough loads.

The assumption that the predominant deformations of a floating ice plate are caused by shearing forces was also made by Krylov⁷⁴ in 1948.

The intense development of the linear theory of viscoelasticity after World War II also affected the formulation of ice plate problems. In 1944, Golushkevich³⁷ presented an analysis assuming that ice behaves elastically for volumetric deformations and viscoelastically for deviatoric deformations. His formulation was based on the linear bending theory of plates, linear constitutive equations, and the assumption that the material parameters do not vary across the plate thickness. The equations obtained were linear. The special case of an incompressible material was analyzed in detail.

A general formulation for viscoelastic plates, based on the linear bending theory of plates and the assumption that the constitutive equation is a linear relation of differential operators, was presented by Freudenthal³² in 1958. The utilization of this equation for floating ice plates was discussed by Kheishin⁵⁶ in 1964. As a special case, Kheishin analyzed an infinite ice plate subjected to a concentrated load P , assuming that the ice is incompressible for volumetric deformations and that it responds like a Maxwell body for deviatoric deformations. A similar problem, when the load is distributed uniformly over a circular area, was analyzed in 1966 by Nevel,⁹⁴ who also presented graphs and a comparison with the results of a test. In 1970, IAKunin⁴³ presented solutions for various load distributions, assuming that the ice responds like a four element model, that is, a series combination of a Maxwell and Kelvin model. In the above analyses, except for the paper by IAKunin, it was assumed that the material parameters are constant throughout the plate.

As discussed before, in an actual floating ice cover the material parameters vary with depth. In an attempt to take this into consideration, IAKunin⁴³ derived an approximate formulation for a varying modulus of elasticity and coefficient of viscosity, and solved the formulation for a variety of load distributions. He found that, as in the elastic case, the variation of material parameters across the plate thickness has a profound effect upon the stresses in the ice cover.

A viscoelastic analysis of the ice cover based on Reissner's theory of plates, which considers the effect of bending as well as shearing forces upon the deformations, was presented in 1967 and 1968 by Garbaccio.³³ Garbaccio assumed that the ice responds like a series combination of a Maxwell and Kelvin model and that the material parameters are constant throughout the ice plate.

In 1961, Panfilov,⁹⁹ citing shortcomings of linear theories, derived a differential equation for floating ice plates, based on the linear bending theory of plates and the nonlinear viscoelastic constitutive equations proposed by Voitkovskii.^{144, 145} Additional derivations, along the same line, were presented in 1970 by Panfilov,¹¹¹ who, however, gave no solutions to the derived differential equation.

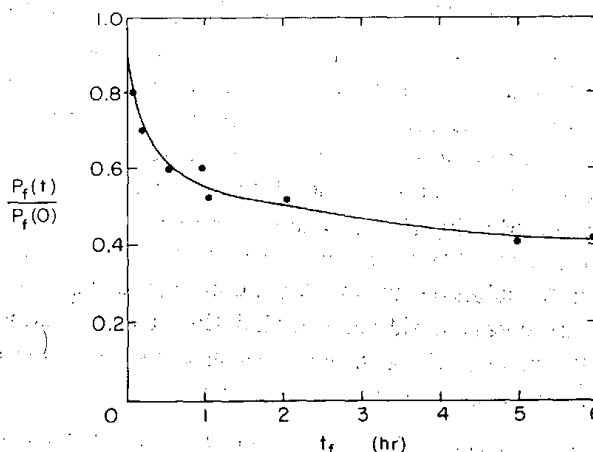

Figure 18. Breakthrough loads vs breakthrough time for a floating ice cover subjected to loads of long duration.

In 1962, Cutcliffe et al.,⁹⁹ using a nonlinear constitutive equation, made an attempt to analyze the time-dependent stresses of an ice cover.

The linear bending theory and a nonlinear constitutive equation were also used by Garbaccio³³ to analyze ice plate problems. Garbaccio attempted to obtain an approximate solution of the resulting nonlinear formulation by a linearization technique.

In the absence of reliable analyses for predicting the bearing capacity of ice plates subjected to loads of long duration, Panfilov,⁹⁹ in 1961, constructed from field test data the graph shown in Figure 18. In Figure 18, t is the time period between placement of the load and breakthrough, $P_f(0)$ is the magnitude of the load

just sufficient to break through immediately after placement on the plate (at $t_f = 0$), as discussed in the previous section,* and $P_f(t_f)$ is the load that breaks through after a time t_f . From the graph shown, it follows that $P_f(t_f) < P_f(0)$ for $t_f > 0$. Thus, for example, a load that has to park safely on the ice plate for 6 hours should be smaller than $0.4 P_f(0)$, where $P_f(0)$ is determined from a separate analysis. To represent analytically the graph shown in Figure 18, Panfilov proposed the expression

$$\frac{P_f(t_f)}{P_f(0)} = \frac{1}{1 + 0.75\sqrt[3]{t_f}} \quad (62)$$

where t_f is in hours. Solving this equation, the "safe" storage time is obtained as the time that is smaller than

$$t_f = \left[\frac{P_f(0) - P_f(t_f)}{0.75 P_f(0)} \right]^3 \quad (63)$$

A graph similar to the one shown in Figure 18 was presented and discussed, also in 1961, by Assur.²

Korunov⁷² in 1968 pointed out that eq 62 was obtained from tests on ice plates under specific conditions. He then proposed the following modification of eq 63:

$$t_f = \left[\frac{P_f(0) - P_f(t_f)}{0.75 P_f(0)n} \right]^3 K \quad (64)$$

where K and n are correction coefficients which take into consideration the shape of the load and the outside temperature.

In 1970, other expressions of the type shown in eq 62 were presented and discussed by Panfilov.¹¹¹ A related discussion is presented in ref. 43.

METHODS BASED ON THE YIELD LINE THEORY OR LIMIT ANALYSIS

The *yield line theory* was utilized for the analysis of continuously supported plates by Johansen⁴⁷ in 1947 and by Bernell⁷ in 1952. Persson¹¹³ used it in 1948 for the analysis of a floating ice plate. Assuming that the yield line moment per unit length is M_0 , Persson obtained for the case shown in Figure 2

$$P_f = \frac{4\pi}{(1+\nu)(1-0.62\alpha^{2/3})} M_0 \quad (65)$$

Using a similar approach, in 1961 Assur² presented for the breakthrough load the expression

$$P_f = \frac{4\pi}{1 - \frac{1}{3}\sqrt[3]{\frac{\pi}{2}}\alpha^2} M_0 \quad (66)$$

* In the previous section, it is denoted for brevity's sake as P_f .

The method of *limit analysis* was utilized by Meyerhof⁸⁵ in 1960 for the analysis of the bearing capacity of floating ice plates. Assuming 1) that the ice plate is thin, rigid and ideally plastic, 2) that it can, without cracking, resist a full plastic moment M_0 , and 3) that the ice obeys the Tresca yield condition, Meyerhof obtained for the case shown in Figure 2

$$P_f = 3.3\pi \left(1 + \frac{3}{2}\alpha\right) M_0 \quad 0.05 < \alpha < 1.0. \quad (67)$$

Assuming that the floating ice plate before failure is cracked radially into numerous wedges, Meyerhof obtained for the same case

$$P_f = \frac{4\pi}{1 - \frac{1}{2}\alpha} M_0 \quad 0.2 < \alpha < 1.0. \quad (68)$$

In an extensive discussion of Meyerhof's paper,²² Hopkins questioned the degree of realism in approximating the mechanical behavior of ice as that of a rigid, perfectly plastic material. In the same discussion, Wood as well as Hopkins questioned the use of the Tresca yield condition.

Recently, Coon and Mohagheh¹⁸ also analyzed the floating ice plate by using the limit analysis method but assumed that the ice obeys Coulomb's law. For the problem shown in Figure 2, they obtained

$$P_f = 2\pi(2.3 + 2.9\alpha)M_0. \quad (69)$$

Additional results and discussions were presented by Coon and Mohagheh¹⁸ and Meyerhof.⁸⁵ Related results were published by Korenev⁶¹ in 1955 and Serebrianyi¹²⁴ in 1960.

It should be noted that the often used expression for the limit bending moment $M_0 = \sigma_0 h^2/4$ is based on a stress distribution of a homogeneous plate, as shown in Figure 19a, whereas because of the thermal gradient in the plate, the distribution of limit stresses,¹¹⁴ assuming that a full plastic moment does exist, could be as shown in Figure 19b. Also, the assumption that the ice plate can, without cracking, resist a full plastic moment M_0 may not be realistic, since its formation was not observed in the field. When using the yield line theory, it may be more realistic to work with *cracks* instead of *yield lines*, and *wedge-in moments* instead of the *plastic moment* M_0 , especially along the radial cracks.

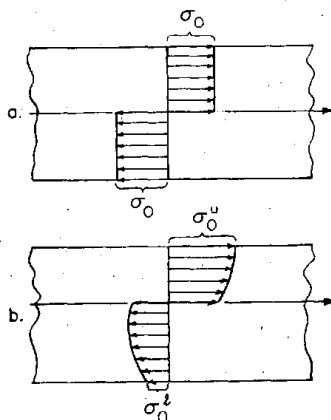

Figure 19. Limit stress distributions. a. Homogeneous plate. b. Nonhomogeneous plate.

A comparison of the various P_f expressions presented above with P_{cr} formula (eq 10a) given by Bernshtein⁸ is shown in Figure 20. For comparison, it was assumed that $\sigma_f = \sigma_0$ and that $M_0 = \sigma_0 h^2/4$. Note that a different number in the denominator of M_0 shifts only vertically a plotted graph. All $P_f/(\sigma_0 h^2)$ versus α graphs obtained using plasticity methods show the same characteristics and may be represented by a straight line, as done in eq 12a or 12b.

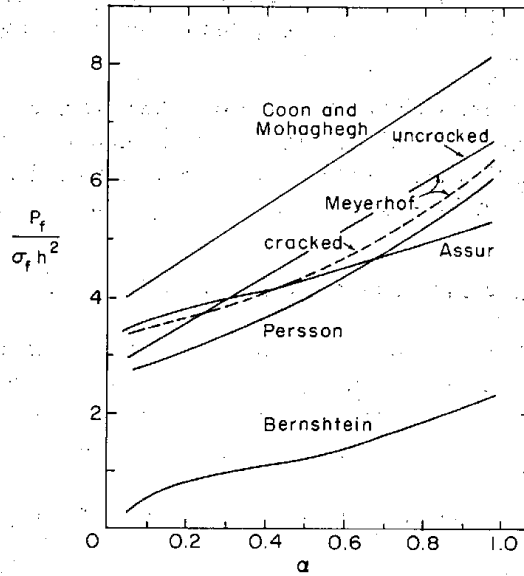

Figure 20. A comparison of P_f expressions with P_{cr} formula (in eq 10a).

COMPARISON OF ANALYTICAL AND TEST RESULTS

General Remarks

The mechanical properties of ice vary drastically in the vicinity of the melting (or freezing) temperature of about 0°C. Because the lower surface of a floating ice plate is usually at the melting temperature, the plate response is obviously affected by it. This effect is especially severe when the upper surface is also subjected to near 0°C temperatures, because then the temperature throughout the plate is approaching the melting temperature.

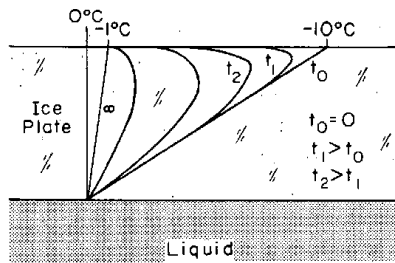

Figure 21. Temperature distributions in a floating ice plate for different times $0 \leq t < \infty$.

To demonstrate the temperature variations with time, consider a floating ice plate subjected for a long time to an air temperature of -10°C. Assume that at time $t = 0$ the air temperature rises to -1°C; the corresponding temperature distributions for different times are shown in Figure 21. Although the temperatures at the top and bottom surfaces are constant for $t > 0$, the temperatures throughout the plate vary with time. Hence, if two identical tests are performed before a thermal steady state is established, the results may differ, depending upon the time (after the temperature rise) a particular test is conducted.

A similar situation takes place in the floating test beams used for the determination of the failure stress σ_f , because after a beam is cut out from the ice the side walls come in contact with the rising water and the outside air.

Another thermal problem may arise in a test when an ice cover in the field is loaded by pumping water into a large tank that rests directly on the cover, for then the bottom of the tank, which is made of metal or canvas, rests on the ice, and the upper surface of the ice plate in the contact

region is subjected to near 0°C temperatures. This type of loading usually causes a change in the stress distribution and a lowering of the strength of the ice in the area where failure usually starts, thus affecting the test results.

These and related questions, such as the effect of a sharp drop of the air temperature, the rate of loading, and the penetration of water through the ice plate during loading, have to be considered when the test data of floating ice plates are correlated with the analytical results. In the following, various test results are discussed and correlated with analyses presented above.

Effect of Bending and Shearing Forces on Deflection of an Ice Cover

As shown in the previous sections, an analytical determination of the breakthrough load utilizes a formulation for the ice cover. In order to simplify the necessary analyses, such a formulation contains a number of assumptions. It is essential that the assumptions made be justified, from a physical point of view, since otherwise the analytical results may have no relevance to the actual problem under consideration.

One such assumption, included in the derivation of differential eq 9, states that a straight line, normal to the reference plane, remains straight and normal to the deformed plane (sometimes denoted as the Kirchhoff hypothesis). Physically, this kinematic assumption implies that the deflections are caused by bending stresses only and that the effect of shearing forces is negligible. This assumption, discussed at length in books on the strength of materials, has been proven to be justified for the elastic response of slender beams and thin plates made of a variety of materials.

On the other hand, basing his view on field observations, Zubov¹⁵⁵ in 1945 suggested that the deflections of an ice cover are mainly caused by shearing forces, and hence the effect of bending upon the deflections is negligible.

Because the resulting equations are used for the analytical determination of P_f (for additional examples, see ref. 102), it is essential to determine whether Kirchhoff's or Zubov's assumption is to be used for the formulation of ice cover problems. In this connection, note that the plate deflections due to a load q , which is distributed over a circular area, according to eq 9, are¹⁵³

$$\begin{aligned} w_1(r) &= \frac{qa}{\gamma} \left[\frac{1}{a} + \text{ker}'(a)\text{ber}(\lambda r) - \text{kei}'(a)\text{bei}(\lambda r) \right] & 0 \leq r \leq a \\ w_2(r) &= \frac{qa}{\gamma} \left[\text{ber}'(a)\text{ker}(\lambda r) - \text{bei}'(a)\text{kei}(\lambda r) \right] & a \leq r \leq \infty \end{aligned} \quad (70)$$

where $\lambda = \sqrt{\gamma/D}$, whereas the differential equation for an ice plate, according to Zubov's hypothesis, is

$$Gh \nabla^2 w - \gamma w = -q \quad (71)$$

where G is the shearing modulus and the corresponding deflections are

$$\begin{aligned} w_1(r) &= \frac{q}{\gamma} \left[1 - (\kappa a)K_1(\kappa a)I_0(\kappa r) \right] & 0 \leq r \leq a \\ w_2(r) &= \frac{q}{\gamma} (\kappa a)I_1(\kappa a)K_0(\kappa r) & a \leq r \leq \infty \end{aligned} \quad (72)$$

THE BEARING CAPACITY OF FLOATING ICE PLATES

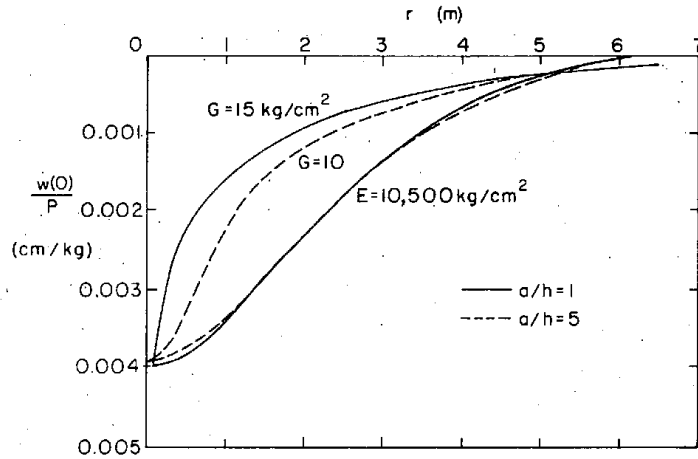

Figure 22. Comparison of plate deflection curves based on bending and shear theories.

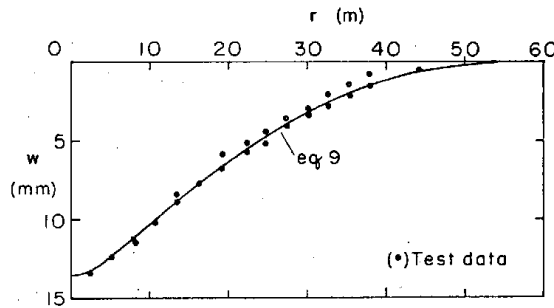

Figure 23. Comparison of ice plate deflections due to loads of short duration at $-15^{\circ}\text{C} < T < -7^{\circ}\text{C}$.

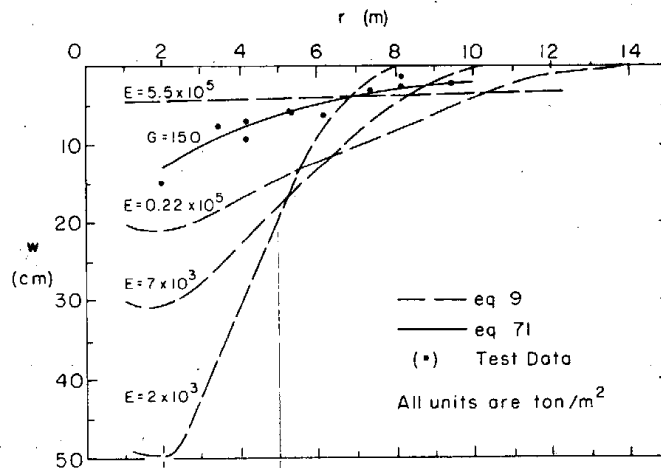

Figure 24. Comparison of ice plate deflections due to loads of short duration at 0°C .¹³¹

where I_0, K_0, I_1 and K_1 are Bessel functions and $\kappa = \sqrt{\gamma/(Gh)}$. To show the different nature of the deflection curves based on these two assumptions, eq 70 and 72 were evaluated numerically for $h = 10$ cm, $\nu = 0.3$, and $E = 10,500$ kg/cm². For $a/h = 1$ and 5 , the corresponding value of G was determined using the condition that the largest deflections $w(0)$ for both theories are equal. The results are shown in Figure 22.

Note that the response of an ice cover according to Zubov¹⁵⁵ is identical to the response of the shear layer in the Pasternak foundation.⁵¹

As early as 1929, Bernshtein⁸ compared the deflections of an ice field on the Volga River subjected to loads of short duration, at air temperatures of $-15^{\circ}\text{C} < T < -7^{\circ}\text{C}$, with corresponding results based on eq 9. This comparison is shown in Figure 23. Since the agreement is very close, it was concluded that the use of eq 9, and hence Kirchoff's hypothesis, is justified for the formulation of ice plate problems subjected to loads of short duration.

In 1968, Shmatkov¹²¹ compared test data of an ice plate on Lake Baikal subjected to a vertical load of short duration but at air temperatures of about 0°C with analytical results based on eq 9 and 71. This comparison is given in Figure 24. On the basis of these data, Shmatkov concluded that at air temperatures of about 0°C the deformations are mainly caused by shearing forces.

This conclusion raises a serious question about the effect of the air temperature upon the range of validity of eq 9 and 71 for the formulation of ice covers. A comparative study involving more test data, especially at air temperatures near 0°C , is urgently needed to clarify this important question. In these tests, a special effort should be made to separate the elastic from the nonelastic deformations. It may also be advisable to note the difference between the crystallographic structure of an ice cover formed over a lake in which the water is essentially at rest and that over a river in which the water moves at a certain velocity, and the effect of a different crystallographic structure upon the mechanical properties of an ice cover.

Determination of $P_f(0)$

Test results and their relationship to the allowable load given by the analogy method were discussed by Kliucharev and Iziumov⁵⁷ in 1943 and by Kobeko et al.⁵⁹ in 1946. In 1960, Gold³⁴ compared eq 4 with the field results of the Canadian pulp and paper industry. The conclusion from this comparison was that the formula given in eq 4 is not sufficient for the determination of failure loads since the presence of cracks, thermal stresses and natural variation in effective thickness is not considered. Another reason could be that the failure load P_f is not proportional to h^2 but may be a more complicated function of h , as indicated by eq 10 and 12. Additional results were presented by Gold³⁵ in 1971.

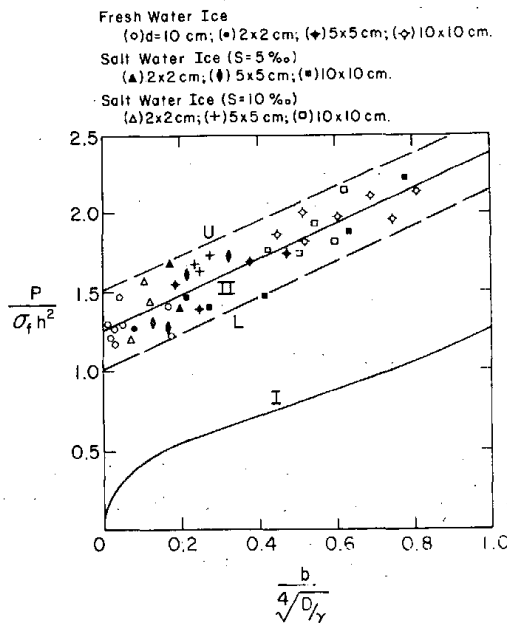

Figure 25. Laboratory test results for infinite plates.⁹⁸

In order to establish which of the various formulas for P_{cr} and $P_f(0)$ obtained using the criterion $\sigma_{max} = \sigma_f$ are suitable for predicting the carrying capacity of a floating plate subjected to loads of short duration, in the following the analytically obtained $P_f(0)$ values are compared with corresponding results from tests conducted on floating ice plates.

Since the analyses are based on an elastic theory, only the results of tests with very short loading times to failure are of interest. Such tests were recently conducted by Panfilov⁹⁸ in the laboratory as well as in the field. The laboratory tests were conducted at -10°C . The floating plate was loaded by means of stamps of the dimensions shown in Figure 25. The load for each test was placed statically at rates which caused breakthrough within 5 to 20 sec. In addition to the failure loads P_f , loads at which the first radial crack occurred

P_{cr} were recorded. The laboratory tests were conducted with fresh and salt water ice. The ice plate thickness varied from 7 to 30 mm. The field tests were conducted on thicker ice plates. The ice plate was loaded by placing metal water tanks on a structure which in turn rested on the ice plate and simulated the contours of wheel loads. The ice strength σ_f was determined from floating cantilever tests with the load acting downwards. Additional details are contained in ref. 98.

The results of 56 laboratory tests for the infinite plate are shown in Figure 25.

The failures followed the usual pattern: first, the formation of radial cracks that emanated from the region under the load; then, the formation of circumferential cracks, at which time the load broke through the plate.

In Figure 25, Curve I is the $P_{cr}/(\sigma_f h^2)$, according to the analyses by Bernshtein,⁸ Golushkevich,³⁷ and Wyman.¹⁵³ Curve II is proposed by Panfilov⁹⁸ as representing the test data and is described by the equation

$$\frac{P}{\sigma_f h^2} = 1.25 + 1.05 \frac{b}{\ell}$$

This equation was obtained by an averaging process. The test data show a scatter in a relatively narrow band.

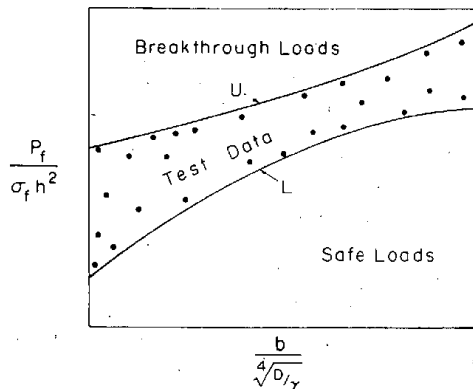

Figure 26. Illustration of new concept for evaluating breakthrough loads from test data.

breakthrough loads. The area between the envelopes is the region of the test failure loads and nothing definite can be said about it with respect to safety or breakthrough. Thus, only the regions above curve U and below curve L are of interest and the test results are needed to separate these two regions.

For the test data of infinite plates shown in Figure 25, the upper envelope U may be represented by the equation

$$\left(\frac{P_f}{\sigma_f h^2} \right)_U = 1.5 + 1.1 \frac{b}{\ell}$$

and the lower envelope L by the equation

Before proceeding with the discussion of these test results, in the following a different concept for the evaluation of ice plate tests is introduced. This is necessary because averaging curves, such as curve II, are not suitable for most engineering purposes.

From an engineering point of view, there is a need to determine *safe loads*, at which an object may move or park briefly on a floating ice plate, or *breakthrough loads*, for the design of ice breakers, at which the plate definitely collapses. These loads may be obtained by introducing into the results of field tests an upper envelope U and a lower envelope L , as shown in Figure 26. It is reasonable to expect that the area under envelope L contains *safe loads* and the area above envelope U the

$$\left(\frac{P_f}{\sigma_f h^2}\right)_L = 1.0 + 1.2 \frac{b}{\ell}$$

Therefore, if the bounds shown in Figure 25 should prove reproducible by other investigators, a safe load (for loads of short duration and $T = -10^\circ\text{C}$) could be determined from the condition

$$P < \left(1.0 + 1.2 \frac{b}{\sqrt{D/\gamma}}\right) \sigma_f h^2 \quad (73)$$

where σ_f is obtained from a floating cantilever beam test loaded downward.

According to test data shown in Figure 25

$$\left(P_f^{\text{test}}\right)_L \cong 2 P_{\text{cr}} \quad (74)$$

Note, however, that the σ_f values for these two cases are usually not the same.

Panfilov⁹⁸ observed that, if P_{cr} is the load at which the first crack takes place, then

$$P_{\text{cr}}^{\text{test}} \cong \frac{2}{3} P_f^{\text{test}} \quad (75)$$

From the above two equations, it then follows that

$$P_{\text{cr}}^{\text{test}} \cong \frac{4}{3} P_{\text{cr}} \quad (76)$$

A proper analysis should yield that P_{cr} is equal to $P_{\text{cr}}^{\text{test}}$. Possible reasons that this is not so in eq 76 are: 1) The σ_f values used in Figure 25 are those obtained by loading the cantilever beam downward, whereas for the determination of P_{cr} the tensile stresses that crack the plate are in the lower fibers of the plate where σ_f is smaller because of the higher temperatures; 2) The stress distribution is not linear across the plate thickness and the stresses in the upper fibers are larger than those in the bottom fibers, whereas the analyses and test evaluation are based on a linear distribution with equal stresses at the top and bottom fibers; and 3) The criterion $\sigma_{\text{max}} = \sigma_f$ may not be valid.

According to analytical results by Kashtelian,⁴⁸ for an infinite plate that cracks into five wedges ($\phi_n = 2\pi/5$)

$$\frac{P_f}{\sigma_f h^2} = 2.08 \frac{\phi_n}{\pi} \cong 0.8$$

and when plates crack into six wedges ($\phi_n = \pi/3$)

$$\frac{P_f}{\sigma_f h^2} \cong 0.7.$$

Thus, according to this analysis, P_f values are obtained which are far below the test data presented in Figure 25.

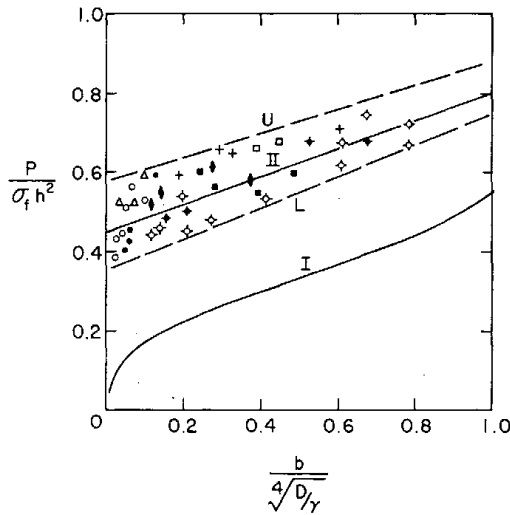

Figure 27. Results for semi-infinite plate.⁹⁸
(Symbols as in Fig. 25.)

$$\frac{P}{\sigma_f h^2} = 0.45 + 0.38 \frac{b}{\ell}$$

It can be easily verified that the upper envelope U is described by the equation

$$\left(\frac{P}{\sigma_f h^2} \right)_U = 0.58 + 0.27 \frac{b}{\ell}$$

and the lower envelope L by the equation

$$\left(\frac{P}{\sigma_f h^2} \right)_L = 0.35 + 0.39 \frac{b}{\ell}$$

Hence, if the bounds shown in Figure 27 should prove to be reproducible by other investigators, a safe load for the crossing of a long gap in a floating plate (a bridge between two semi-infinite plates) could be determined from the condition

$$P < \left(0.35 + 0.39 \frac{b}{\sqrt{D/\gamma}} \right) h^2 \sigma_f$$

On the other hand, the breakthrough load for a semi-infinite plate, often needed for the design of icebreakers, should satisfy the condition

$$P > \left(0.58 + 0.27 \frac{b}{\sqrt{D/\gamma}} \right) \sigma_f h^2$$

where σ_f is determined from a floating cantilever test loaded downward.

According to the test data shown in Figure 27, for $0.1 < b/\ell < 1.0$

Also compare the graphs presented in Figure 20 with the test data of Figure 25. Note that the upper graphs in Figure 20 are based on $M_0 = \sigma_0 h^2/4$ and that they may be shifted toward the test data by choosing a larger number in the denominator of M_0 .

The test results for a semi-infinite plate subjected to an edge load, as shown in Figure 6, are presented in Figure 27. The failures followed the usual pattern: first, the formation of a crack, which emanates under the load and is normal to the free boundary; then the formation of a circumferential crack at which the two wedges break off.

In Figure 27, Curve I is the P_{cr} , according to the analyses of Shapiro¹²⁷ and Golushkevich.³⁷ Curve II was proposed by Panfilov⁹⁸ as representing the test data, which show a scatter in a relatively narrow band. It is described by the equation

$$\left(P_f^{\text{test}}\right)_L \cong 1.6 P_{\text{cr}} \quad (77)$$

Panfilov observed that also for the semi-infinite plate

$$P_{\text{cr}}^{\text{test}} \cong \frac{2}{3} P_f^{\text{test}} \quad (78)$$

From eq 77 and 78, it then follows that

$$P_{\text{cr}}^{\text{test}} \cong 1.1 P_{\text{cr}} \quad (79)$$

In view of the three possible shortcomings listed in the discussion of the infinite plate, this agreement is very close.

Panfilov's test results for the infinite and semi-infinite plate show that

$$\left(P_f^{\text{test}}\right)_{\text{inf plate}} \cong 2.7 \left(P_f^{\text{test}}\right)_{\text{semi-inf plate}} \quad (80)$$

This contradicts the experimental findings reported by Kashtelian (ref. 48, p. 33). Equation 80 indicates that the effect of the wedge-in moments is not negligible if one attempts to compute P_f analytically from wedge solutions. Without the wedge-in moments, P_f of the infinite plate would be equal to twice the P_f of the semi-infinite plate. In this connection, note the corresponding relationship obtained analytically and shown in Figure 8.

According to Kashtelian,⁴⁸ for the observed wedge formation, for a semi-infinite plate $\phi = \pi/2$ and hence

$$P_{\text{cr}}/(\sigma_f h^2) = 0.518$$

a value which agrees with the test data shown in Figure 27 for $\alpha < 0.4$.

Other test data for loads of short duration were obtained by Iakunin;⁴³ however, these results were not available for review.

Determination of $P_f(t)$

Early test results for ice covers subjected to loads of long duration were reported in refs. 6, 8, 45, 58 and 59. More recent test results were presented by Sundberg-Falkenmark,¹²⁷ Frankenstein,³⁰ Panfilov,⁹⁹ 106 111 Stevens and Tizzard,¹³⁶ and Iakunin.⁴³ Although some writers compared their test data with analytical results and found satisfactory agreement for certain situations, a systematic study of available test data, supplemented with new test results, is needed to establish, first the proper plate theory for ice covers which will predict the deflections as a function of time, and then a failure criterion for the determination of $P_f(t)$ and t_f .

In connection with the above studies it may also be useful to note the test results presented by Black,⁹ Brunk,¹³ Butiagin,¹⁴ Frankenstein,²⁹ Gold et al.,³⁶ Korzhavin and Butiagin,⁶⁷ and Shishov,¹³⁰ as well as the discussions by Assur,³ Dykins,²⁴ Iakunin,⁴³ Pister,¹¹⁷ and the discussion in ref. 140.

Determination of σ_f

For the analytical determination of $P_f(0)$, the value σ_f is needed. It is determined usually from a beam cut out from an ice plate and tested in situ. A detailed description of such tests was given by Butiagin (ref. 16, section IV). A cantilever test beam is shown in Figure 28.

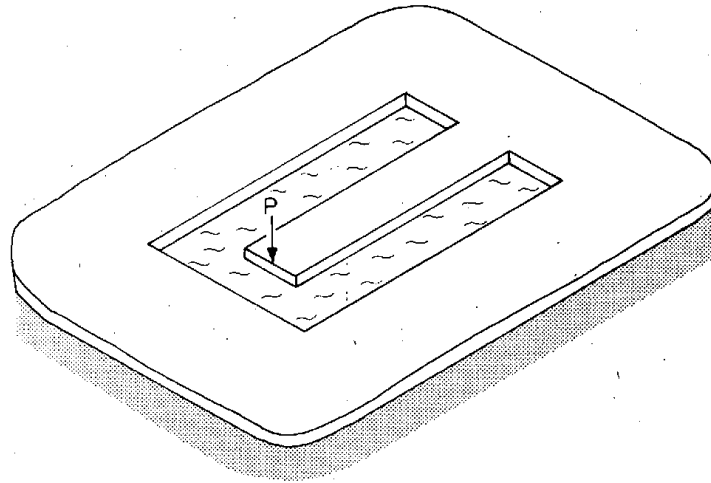

Figure 28. Cantilever test beam for the determination of σ_f .

Other test data were presented by Brown,¹² Frankenstein,^{27 28} Sokolnikov,¹³⁴ Tabata et al.,¹³⁸ Tauriainen,¹³⁹ and Weeks and Anderson.¹⁴⁷ Related questions were discussed by Butiagin,¹⁵ Frankenstein,³¹ Kerr and Palmer,⁵⁵ Lavrov,^{77 78} Peschanskii,¹¹⁴ Savel'ev,¹²¹ Smirnov,¹³³ and Weeks and Assur.¹⁴⁹

In order to establish a standard procedure for the determination of σ_f , it should be of interest also to determine the effect of the rate of loading upon σ_f , as well as to clarify why Frankenstein,^{27 28} using the test setup shown in Figure 28, found that the determined σ_f value was higher when P acted upwards, whereas Butiagin,¹⁵ using the same setup, reported that, according to his test results, the σ_f value was higher when P acted downwards.

SUMMARY AND RECOMMENDATIONS

When utilizing a floating ice plate for storage purposes or as a pavement for moving vehicles, there is a need to know the magnitude of the *breakthrough load* $P_f(t)$ and the corresponding *time to failure* t_f . Until now, there has been no general theory in the literature suitable for the prediction of $P_f(t)$. The majority of papers on the bearing capacity of ice plates have dealt with the determination of $P_f(0)$, that is, the load which is just sufficient to break through the ice immediately after it is placed on the ice cover. Only a few papers have dealt with the determination of $P_f(t)$. The procedures for the determination of $P_f(0)$ and $P_f(t)$ are summarized in the following:

$P_f(0)$				$P_f(t)$	
Based on elasticity analyses		Based on plasticity analyses			
Analogy method for determination of P_{all} .	Determination of P_{cr} based on elasticity theory of plates and criterion $\sigma_{max} = \sigma_f$. Then correlation of P_{cr} and $P_f(0)$.	Direct determination of $P_f(0)$ by analyzing the cracked plate. Use of elasticity theory and criterion $\sigma_{max} = \sigma_f$.	Determination of $P_f(0)$ using yield line theory.	Determination of $P_f(0)$ using limit load theory.	Use of a viscoelastic theory in conjunction with a failure criterion.

Attempts to determine $P_f(0)$ are based on elasticity as well as plasticity theories:

The foundations of the *analog method*, which utilizes relationships of an elasticity analysis, are questionable. Thus, the results obtained with this method, although very simple, should be used with caution. In this connection, note the position of eq 7 in Figure 25 as compared with some findings by Gold.^{34 35}

Another approach is based on the *elasticity theory of plates*. In this procedure, for the given load the maximum stress in the plate σ_{\max} is determined first, then eq 8, $\sigma_{\max} = \sigma_f$, is used to determine P_{cr} , a load which is just sufficient to cause the first crack. Since, according to field tests for infinite and semi-infinite plates, $P_f(0) > P_{cr}$, an empirical relation between P_{cr} and $P_f(0)$ is needed for the determination of $P_f(0)$. Equation 74, which is based on data by Panfilov,⁹⁸ if proven to be generally valid, could be used as such an empirical relation for the infinite plate. In this procedure, σ_f is determined from a floating ice beam that fails in tension in the bottom region of the cross section.

In still another approach, the empirical relation is eliminated and $P_f(0)$ is determined directly, by using the *elasticity theory for the analysis of the cracked ice plate*, which consists of wedges that emanate from the loaded region and the assumption that $P_f(0)$ is reached when the wedges break off. Equation 8 is also utilized as the crack criterion. The value for σ_f is obtained from a floating ice beam that fails in tension in the upper region of the cross section.

The publications that follow either of these two approaches contain several questionable assumptions; for example, although in a floating ice plate the material parameters, especially E , usually vary throughout the thickness, the expression valid for a linear distribution of bending stresses is used exclusively for the determination of the maximum stress in the plate. Also, the use of above equations for the determination of σ_f from a beam test may not be justified.⁵⁵

Another questionable practice is the utilization of eq 8 as the failure criterion. Equation 8 is the well known *maximum stress* criterion.^{26 141} It implies that the failure stress σ_f is not affected by any other stresses at the point of failure. Tests have shown that eq 8 is applicable to a variety of brittle materials when not subjected to hydrostatic compression. Although many publications dealing with the bearing capacity of floating ice plates utilize eq 8, not a single publication could be located which describes test results that prove, or disprove, the validity of this criterion for floating ice plates. This situation is very unsatisfactory, since σ_{\max} in plates is usually biaxial, whereas the σ_f value is determined from a test with uniaxial bending stress. In 1970, Panfilov¹¹⁰ suggested the criterion

$$\sigma_1 - \mu\sigma_2 \leq \sigma_f \quad (81)$$

which is the two-dimensional version of the well known *maximum strain* criterion. However, Panfilov¹¹⁰ did not offer sufficient experimental data to justify the use of this criterion either. In the literature on the mechanics of materials, several other failure criteria are described that may or may not be suitable for floating ice plates. For an early discussion related to plates on a Winkler base, the reader is referred to section 9 of ref. 123. It appears that first it has to be established whether the simple criterion in eq 8, which is also applicable for materials with different σ_f values for tension and compression, is valid for floating ice plates subjected to vertical and in-plane loads.

An additional shortcoming of the publications that analyze the cracked plate is that the investigators neglect the wedge-in moments in the radial cracks. This does not seem to be permissible, in view of the tests by Panfilov,⁹⁸ who found that $P_f(0)$ of an infinite plate is larger than $2P_f(0)$ for a semi-infinite plate.

The approaches for the determination of $P_f(0)$ that are based on plasticity theories utilize the *yield line* or *limit load* analysis. For a discussion of a possible shortcoming of these two analyses, the reader is referred to the listed references. Note that the yield line theory is conceptually related

to the approach discussed above, which analyzes the cracked plate. In this connection, it may be more realistic to work with cracks instead of yield lines and wedge-in moments instead of plastic moments, especially along the radial cracks.

In view of the variations of ice properties in an actual ice cover and their effect upon $P_f(0)$, it may be advisable from a practical point of view to use the concept presented in Figure 26. Its theoretical justification is that the straight-line upper or lower bounds of $P_f(0)$ are of the form

$$\frac{P_f}{\sigma_f h^2} = A + B\alpha$$

which relates the concept to the various analyses discussed above. This approach, if restricted to straight-line bounds, is essentially the same as the one discussed by Papkovich,¹¹² except for the introduction of the notion of upper and lower bounds for $P_f(0)$. Also, note the similarity of the trend of the graphs and test data shown in Figures 4, 20 and 25.

The experimental data for $P_f(0)$ presented by Panfilov⁹⁸ (Fig. 25 and 27) show little scatter. More test data are needed to establish whether the P_f values for other ice plates, tested under different conditions, fall in the same range.

The analytical determination of $P_f(t)$ has received much less attention than the determination of $P_f(0)$. It is reasonable to assume that the necessary formulation consists of a *viscoelastic plate theory and a failure criterion*. Thus, it is essential first to establish the range of validity of a simple formulation consisting of a *linear viscoelastic plate theory* (a bending theory, a shear theory, or a combination of both effects) in conjunction with a failure criterion of the type expressed in eq 58.

Until reliable analytical methods are developed for predicting $P_f(t)$ and t_f , from a practical point of view, it appears advisable to establish whether the empirical relation expressed in eq 62 or a similar expression, as proposed by Assur,² is generally valid. The test results needed for this purpose are also necessary for formulating the proper failure criterion as well as for establishing the validity of a chosen viscoelastic plate theory.

LITERATURE CITED

1. Assur, A. (1956) Airfields on floating ice sheets for regular and emergency operations. U.S. Army Snow, Ice and Permafrost Research Establishment (USA SIPRE) Technical Report 36. AD 099688.
2. Assur, A. (1961) Traffic over frozen or crusted surfaces. *Proc. First International Conference on the Mechanics of Soil-Vehicle Systems*, Torino, Italy, Edizioni Minerva Tecnica.
3. Assur, A. (1962) Surfacing submarines through ice. *Proc. Army Science Conference*, vol. I.
4. Assur, A. (1967) Flexural and other properties of sea ice sheets. *Proc. of the International Conference on Low Temperature Science* (H. Oura, Ed.), Hokkaido University.
5. Banin, A.P. (1960) Safety fundamentals when working on ice covers (text in Russian). *Stroitel'stvo Truboprovodov*, no. 3.

6. Bearing capacity of natural ice cover (text in Japanese) (1941) In *Studies on river ice, Pt. III*. South Manchurian Railway Company. U.S. Army Cold Regions Research and Engineering Laboratory (USA CRREL) Internal Report 95 (unpublished).
7. Bernell, L. (1952) Process of failure in statically reinforced concrete pavements (in Swedish, with English summary). *Betong*, vol. 37, no. 2.
8. Bernshtein, S. (1929) The railway ice crossing (text in Russian). *Trudy Nauchno-Tekhnicheskogo Komiteta Narodnogo Komissariata Putei Soobshcheniia*, vol. 84.
9. Black, L.D. (1958) Relative strength of plates on elastic foundation. *Transactions Engineering Institute of Canada*, vol. 2.
10. Bogorodskii, V.V., A.V. Gusev and G.P. Khokhlov (1971) The physics of fresh water ice (text in Russian). *Gidrometeorologicheskoe Izd*, Leningrad.
11. Bregman, G.R. and B.V. Proskuriakov (Ed.) (1943) Ice crossings (text in Russian). *Gidrometeoizdat*, Sverdlovsk, Moscow.
12. Brown, J.H. (1962) Elasticity and strength of sea ice. In *Snow and Ice* (W.D. Kingery, Ed.). Cambridge, Mass.: MIT Press.
13. Brunk, H. (1964) Über die Tragfähigkeit von Eisdecken. Dissertation, Technical University of Braunschweig, Germany.
14. Butiagin, I.P. (1955) The investigation of strength of the ice cover of the Ob River during the spring season (text in Russian). *Meteorologia i Hidrologia*, no. 3.
15. Butiagin, I.P. (1958) On the strength of an ice cover subjected to shearing forces (text in Russian). AN SSSR, Zapadno-Sibirskii Filial, *Trudy Transp.-Energ. Inst.*, Novosibirsk.
16. Butiagin, I.P. (1966) The strength of ice and the ice cover (text in Russian). *Izd. Nauka*, Novosibirsk.
17. Chikovskiy, S.S. (1966) Load bearing capacity of the fast ice in the Mirny area (text in Russian). *Sovetskaia Antarkticheskaiia Ekspeditsiia, Informatsionny Biulleten*, no. 55.
18. Coon, M.D. and M.M. Mohagheh (1972) Plastic analysis of Coulomb plates and its application to the bearing capacity of sea ice. University of Washington Report.
19. Cutliffe, J.L., W.D. Kingery and R.L. Coble (1962) Elastic and time-dependent deformation of ice sheets. In *Snow and Ice* (W.D. Kingery, Ed.). Cambridge, Mass.: MIT Press.
20. Daily, A.F. (1969) Off-the-ice placer prospecting for gold. First Annual Off-Shore Technology Conference, Dallas, Texas, Paper OTC 1029.
21. Dieudonne, J. (1957) Study of the equation $\frac{d^4y}{dx^4} + \frac{2}{x} \frac{d^3y}{dx^3} + y = 0$ for $x \geq 0$ (unpublished manuscript). Results reproduced in *The solution of $\frac{d^4y}{dx^4} + \frac{2}{x} \frac{d^3y}{dx^3} + y = 0$* . USA CRREL Technical Note, 1965 (unpublished).
22. Discussion of Bearing capacity of floating ice sheets (1961) *Transactions American Society of Civil Engineers* (ASCE), p. 557-581.
23. Duff, C.H. (1958) Ice landings. *Transactions Engineering Institute of Canada*, vol. 2.

24. Dykins, J.E. (No date) Review of sea ice sheet loading. U.S. Naval Civil Engineering Laboratory.
25. Establishing airfields on ice (1968) U.S. Air Force, Alaskan Air Command, AACP 88-1, November.
26. Filonenko-Borodich, M.M. (1961) Mechanical theories of failure (text in Russian). *Izd. Moskovskogo Universiteta*.
27. Frankenstein, G.E. (1959) Strength data on lake ice. USA SIPRE Technical Report 59. AD 236204.
28. Frankenstein, G.E. (1961) Strength data on lake ice. USA SIPRE Technical Report 80. AD 701054.
29. Frankenstein, G.E. (1963) Load test data for lake ice sheets. USA CRREL Technical Report 89. AD 414955.
30. Frankenstein, G.E. (1966) Strength of ice sheets. *Proc. Conference on Ice Pressures Against Structures*, Laval University, Quebec, Canada.
31. Frankenstein, G.E. (1969) The flexural strength of sea ice as determined from salinity and temperature profiles. Presented at Conference on Snow and Ice, National Research Council of Canada.
32. Freudenthal, A.M. and H. Geiringer (1958) The mathematical theories of the inelastic continuum. In *Encyclopedia of Physics* (S. Flügge, Ed.), vol. 6. Berlin: Springer Verlag.
33. Garbaccio, D.H. (1967-1968) Creep of floating ice sheets. Science Engineering Associates Report No. CR-67.025, April 1967; and Report No. CR-69-014, December 1968.
34. Gold, L.W. (1960) Field study on the load bearing capacity of ice covers. *Woodlands Review, Pulp and Paper Magazine of Canada*, vol. 61, May.
35. Gold, L.W. (1971) Use of ice covers for transportation. *Canadian Geotechnical Journal*, no. 2.
36. Gold, L.W., L.D. Black, F. Trofimenkof and D. Matz (1958) Deflections of plates on elastic foundation. *Transactions Engineering Institute of Canada*, vol. 2.
37. Golushkevich, S.S. (1944) On some problems of the theory of bending of floating ice plates (text in Russian). Dissertation.
38. Gouré, L. (1964) *The siege of Leningrad*. New York: McGraw-Hill. Index, p. 360, under *Ice-road*.
39. Gusev, O.V. (1961) Crossings over ice (text in Russian). *Gidrometeorologicheskoe Izd*, Leningrad.
40. Herbert, W. (1970) The first surface crossing of the Arctic Ocean. *Geographical Journal*, vol. 136, Dec.
41. Hertz, H. (1884) Über das Gleichgewicht schwimmender elastischer Platten. *Wiedemann's Annalen der Phys. und Chem*, vol. 22. English translation, On the equilibrium of floating elastic plates, is included in *Miscellaneous Papers* by H. Hertz, 1896. London and New York: MacMillan and Co.
42. Hetényi, M. (1946) *Beams on elastic foundation*. Ann Arbor: University of Michigan Press.

43. Iakunin, A.E. (1970) The investigation of the effect of the loading time on the bearing capacity of an ice cover (text in Russian). Dissertation for the degree of Kandidat Tekhnicheskikh Nauk, Novosibirskii Institut Inzhenerov Zh/D Transporta, Novosibirsk.
44. Instructions of the Engineering Committee of the Red Army (text in Russian) 1946.
45. Investigation of construction and maintenance of airdromes on ice, 1946-1947 (1947) Soils Laboratory New England Division, Corps of Engineers, U.S. Army, May; revised May 1948.
46. Jansson, I.E. (1956) Icebreakers and their design. In *European Shipbuilding*, no. 5, 6.
47. Johansen, K.W. (1947) Experiments on reinforced concrete plates on an elastic foundation (text in Swedish). *Betong*, vol. 32, no. 3.
48. Kashtelian, V.I. (1960) An approximate determination of forces which break up a floating ice plate (text in Russian). *Problemy Arktiki i Antarktiki*, no. 5.
49. Kerr, A.D. (1959) Plastic deformation of floating ice plates subjected to static loads. USA SIPRE Research Report 57. AD 237533.
50. Kerr, A.D. (1959) Elastic plates on a liquid foundation. *Proc. ASCE*, EM 3, June. Also, Elastic plates with simply supported straight boundaries, resting on a liquid foundation, USA CRREL Research Report 59. AD 237338.
51. Kerr, A.D. (1964) Elastic and viscoelastic foundation models. *Journal of Applied Mechanics*, vol. 31.
52. Kerr, A.D. (1965) Bending of circular plates sealing an incompressible liquid. *Journal of Applied Mechanics*, vol. 32.
53. Kerr, A.D. (1966) On plates sealing an incompressible liquid. *International Journal of Mechanical Sciences*, vol. 8.
54. Kerr, A.D. and R.S. Becker (1967) The stress analysis of circular plates sealing a compressible liquid. *International Journal of Mechanical Sciences*, vol. 9.
55. Kerr, A.D. and W.T. Palmer (1972) The deformations and stresses in floating ice plates. *Acta Mechanica*.
56. Kheishin, D.E. (1964) On the problem of the elastic-plastic bending of an ice cover (text in Russian). *Trudy, Leningrad. Arkticheskii i Antarkticheskii Nauchno-Issledov. Inst.*, vol. 267.
57. Kliucharev, V. and S. Iziumov (1943) Determination of the carrying capacity of ice crossings (text in Russian). *Voenno-Inzhenernyi Zhurnal*, vol. 2-3.
58. Kobeko, P.P., N.I. Shishkin, F.I. Marei and N.S. Ivanova (1946) Plastic deformations and viscosity of ice (text in Russian). *Zhurnal Tekhnicheskoi Fiziki*.
59. Kobeko, P.P., N.I. Shishkin, F.I. Marei and N.S. Ivanova (1946) The breakthrough and carrying capacity of a floating ice cover (text in Russian). *Zhurnal Tekhnicheskoi Fiziki*, vol. 16, no. 3.
60. Korenev, B.G. (1954) Analysis of beams and plates on elastic foundation (text in Russian). Stroiizdat, Moscow.
61. Korenev, B.G. (1955) On the analysis of an infinite plate resting on an elastic foundation taking into consideration plastic deformations (text in Russian). *Sbornik CNIPS, Issledovania Prochnosti; Plastichnosti i Polzuchesti Stroitel'nykh Materialov, Gos. Izd. Lit. Stroit. Arkh.*, Moscow.

62. Korenev, B.G. (1957) Structures on elastic foundation. In *Structural Mechanics in the USSR 1917-1957* (I.M. Rabinovich, Ed.). Gos. Izd. Lit. Stroit. Arkh.
63. Korenev, B.G. (1960) Problems in the theory of elasticity and heat transfer solvable by means of Bessel functions (text in Russian). *Fizmatgiz*.
64. Korenev, B.G. (1969) Structures on elastic foundation. In *Structural Mechanics in the USSR 1917-1967* (I.M. Rabinovich, Ed.). Stroizdat, Moscow.
65. Korenev, B.G. and E.I. Chernigovskaia (1962) Analysis of plates on elastic foundation (text in Russian). Gos. Izd. Lit. Stroit. Arkhitekt. i Stroit. Mat., Moscow.
66. Korzhavin, K.N. (1962) Action of ice on engineering structures. *Izd. Sibir. Otd. AN SSSR*. USA CRREL Translation 260, 1971. AD 723169.
67. Korzhavin, K.N. and I.P. Butiagin (1961) Determination of deformations and strength of ice covers in their natural environment (text in Russian). *Voprosy Ledometriki, Izd. Sibir. Otd. AN SSSR*.
68. Korunov, M.M. (1939-1940) The calculation of ice crossings (text in Russian). *Avto-bronetankovyi Zhurnal*, no. 8, 1939; no. 2, 11, 1940.
69. Korunov, M.M. (1940) The calculation of ice crossings (text in Russian). *Goslestekhhizdat*, Moscow.
70. Korunov, M.M. (1956) Load carrying capacity of ice for timber transport (text in Russian). *Lesnaia Promyshlennost*. Translated into English by the National Research Council of Canada, TT 863.
71. Korunov, M.M. (1967) An approximate method for the determination of the bearing capacity of an ice cover (text in Russian). *Trudy Sverdlovsk Nauchno-Issledovatel'ski Institut Lesnoi Promyshlennosti*, vol. 3.
72. Korunov, M.M. (1968) The safety of loads of long duration resting on ice covers (text in Russian). *Izvestia Vuzov, Lesnoi Zhurnal*, no. 3.
73. Kovacs, A. (1970) On the structure of pressured sea ice. USA CRREL, report prepared for U.S. Coast Guard, MIPR no. Z-70099-02553.
74. Krylov, Ju.M. (1948) The propagation of long waves under an ice cover (text in Russian). *Trudy Gos. Okeanograf. Inst.*, vyp. 8, no. 20.
75. Kubo, Y. (1958) Loading capacity of ice-plate (text in Japanese). *Journal of the Japanese Society of Snow and Ice*, Pt. I, vol. 20, no. 3; Pt. II, vol. 20, no. 4.
76. Lagutin, B.L. and A.P. Shulman (1946) Methods of calculating the load carrying capacity of ice crossing (text in Russian). *Trudy Nauchno-Issledovatel'skikh Uchrezhdenii, Sverdlovsk, Moscow* (B.L. Lagutin, Ed.), seria 5, vyp. 20. Translated by the Arctic Construction and Frost Effects Laboratory (ACFEL), 1954.
77. Lavrov, V.V. (1965) The influence of ice structure upon its strength (text in Russian). *Problemy Arktiki i Antarktiki*, vol. 20. English translation available as USA CRREL Translation 306. AD 737823.
78. Lavrov, V.V. (1969) Deformation and strength of ice. *Gidrometeorologicheskoe Izd, Leningrad*. Translated from Russian for the National Science Foundation, Washington, D.C., by the Israel Program for Scientific Translations, Jerusalem, 1971.

79. Lebedev, N.I. (1940) Ice crossings (text in Russian). Voienizdat, Moscow.
80. Lewe, V. (1923) Platten rechteckiger Grundrissteilung auf elastisch nachgiebiger Unterlage. Die umgekehrte Pilzdecke als Fundament. *Der Bauingenieur*.
81. Linell, K.A. (1951) Use of ice as a load-supporting surface. Presented at the American Society of Civil Engineers Annual Convention, New York, Oct.
82. Lysukhin, I.F. (1968) The engineering of river crossings (text in Russian). *Voennoe Izdatel'stvo Ministerstva Oborony SSR, Moscow*.
83. Mahrenholtz, O. (1966) Zur Tragfähigkeit von Eisdecken. *Zeitschrift für Angewandte Mathematik und Mechanik*, vol. 46.
84. Marchuk, A.N. and S.V. Mitta (1966) The utilization of the bearing capacity of the ice cover during construction of the Bratsk hydro-electric power plant (text in Russian). *Gidrotekhnicheskoe Stroitel'stvo*, no. 7.
85. Meyerhof, G.G. (1960) Bearing capacity of floating ice sheets. *Proc. ASCE, EM 5*, Oct.
86. Moskatov, K.A. (1938) Landing of airplanes on ice (text in Russian). *Trudy Arkticheskogo Instituta*, Leningrad, vol. 110.
87. Müller, W. (1952) Zur Theorie der durchlaufenden Fundamentplatten und Pilzdecken mit rechteckigen Last- oder Stützflächen. *Österr. Ingenieur-Archiv*.
88. Müller, W. (1952) Zur Theorie der rechteckigen Fundamentplatten und Pilzdecken. *Ingenieur-Archiv*.
89. Nevel, D.E. (1958) The theory of a narrow infinite wedge on an elastic foundation. *Transactions Engineering Institute of Canada*, vol. 2, no. 3.
90. Nevel, D.E. (1961) The narrow free infinite wedge on an elastic foundation. USA SIPRE Research Report 79. AD 277538.
91. Nevel, D.E. (1963) Circular plates on elastic sealed foundations. USA CRREL Research Report 118. AD 434084.
92. Nevel, D.E. (1965) A semi-infinite plate on an elastic foundation. USA CRREL Research Report 136. AD 616313.
93. Nevel, D.E. (1966) Time dependent deflection of a floating ice sheet. USA CRREL Research Report 196. AD 638717. Also, Summary contained in *Proc., 5th U.S. National Congress of Applied Mechanics*.
94. Nevel, D.E. and A. Assur (1965) Crowds on ice. USA CRREL Technical Note (unpublished).
95. Newman, M. and M. Forray (1962) Thermal stresses and deflections in thin plates with temperature dependent elastic modulus. *Journal of Aerospace Sciences*.
96. Palmer, W.T. (1971) On the analysis of floating ice plates. New York University, Ph.D. Dissertation, July.
97. Panfilov, D.F. (1960) Approximate method to analyze the bearing capacity of an ice cover (text in Russian). *Izvestia Vsesojuznogo Nauchno-Issled, Inst. Gidrotekhniki*, vol. 65.
98. Panfilov, D.F. (1960) Experimental investigation of the carrying capacity of a floating ice plate (text in Russian). *Izvestia Vsesojuznogo Nauchno-Issledovatel'skogo Instituta Gidrotekhniki*, vol. 64.

99. Panfilov, D.F. (1961) To the analysis of a floating ice cover subjected to loads of long duration (text in Russian). *Izvestia Vuzov, Stroitel'stvo i Arkhitektura*, no. 6.
100. Panfilov, D.F. (1963) Bending of a floating infinite ice plate subjected to a static load of short duration (text in Russian). *Izvestia Vuzov, Stroitel'stvo i Arkhitektura*, no. 6.
101. Panfilov, D.F. (1963) Bending of a semi-infinite ice cover subjected to loads along the free edge. *Izvestia Vuzov, Stroitel'stvo i Arkhitektura*, no. 11-12.
102. Panfilov, D.F. (1963) On methods for the determination of the bearing capacity of ice covers (text in Russian). *Gidrotekhnicheskoe Stroitel'stvo*, no. 4.
103. Panfilov, D.F. (1963) Strength check of an ice cover when subjected to the lowering of pipelines. *Stroitel'stvo Truboprovodov*, no. 9.
104. Panfilov, D.F. (1964) Approximate formulas for the determination of the carrying capacity of ice (text in Russian). *Trudy Koordinacionnykh Soveshchenii po Gidrotekhnike*, vyp. X.
105. Panfilov, D.F. (1964) Bending of an ice cover subjected to a static load of short duration (text in Russian). *Trudy Koordinacionnykh Soveshchenii po Gidrotekhnike*, vyp. X.
106. Panfilov, D.F. (1965) On creep deformations of ice (text in Russian). *Trudy Koordinacionnykh Soveshchenii po Gidrotekhnike*, vyp. 23. *Izd. Energia*, Moscow-Leningrad.
107. Panfilov, D.F. (1966) Analysis of the bearing capacity of an ice cover taking into consideration its nonhomogeneity with height (text in Russian). *Izvestia Vuzov, Stroitel'stvo i Arkhitektura*, no. 2.
108. Panfilov, D.F. (1966) Bending of the infinite ice strip which is subjected to a load of short duration (text in Russian). *Izvestia Vuzov, Stroitel'stvo i Arkhitektura*, no. 12.
109. Panfilov, D.F. (1970) Bending of a floating ice strip subjected to local loads near the edge (text in Russian). *Izvestia Vuzov, Stroitel'stvo i Arkhitektura*, no. 1.
110. Panfilov, D.F. (1970) Calculating ice cover strength (text in Russian). *Izvestia Vuzov, Stroitel'stvo i Arkhitektura*, no. 6.
111. Panfilov, D.F. (1970) The change of the bearing capacity of an ice cover due to loads of long duration (text in Russian). *Izvestia Vuzov, Stroitel'stvo i Arkhitektura*, no. 3.
112. Papkovich, P.F. (1945) Naval structural mechanics (text in Russian). *Sudpromgiz*. Also in *Collected Works on Naval Structural Mechanics*, *Sudpromgiz*, vol. I, p. 424-426, 1962.
113. Persson, B. (1948) Durability and bearing capacity of an ice layer (text in Swedish). *Svenska Vägfareningens Tidskrift*. USA ACFEL Translation 22. AD 042748.
114. Peschanskii, I.S. (1945) The distribution of strength with respect to thickness and its variation in the course of the year (text in Russian). *Problemy Arktiki*, no. 2.
115. Peschanskii, I.S. (1967) Ice science and ice technology (text in Russian). *Gidrometeorologicheskoe Izd*, Leningrad, p. 263.

116. Pickett, G. and G.K. Ray (1951) Influence charts for concrete pavements. *Transactions ASCE*, Paper no. 2425.
117. Pister, K.S. (1965) Mechanical properties of sea ice with reference to structural behavior of ice sheets. U.S. Naval Civil Engineering Laboratory Technical Note N-758.
118. Popov, Ju.N., O.V. Faddeev, D.E. Kheishin and A.A. Jakovlev (1967) The strength of ships which operate in ice (text in Russian). *Izd. Sudostroenie*, Leningrad.
119. Rose, L.B. and C.R. Silversides (1958) The preparation of ice landings by pulp and paper companies in eastern Canada. *Transactions Engineering Institute of Canada*, vol. 2.
120. Roethlisberger, H. (1968) Das Problem der Tragfähigkeit der Eisdecke anlässlich der Zürcher Seegfröni 1963. *Schweizerische Bauzeitung*, 86 Jahrgang.
121. Savel'ev, B.A. (1963) Structure, composition and properties of the ice cover of sea and fresh water (text in Russian). *Izd. Moskovskogo Universiteta*, Moscow, Section 5.
122. Savel'ev, N.G. (1969) Survey and bibliography of papers on the analysis of elements in contact (text in Russian). *Raschety na Prochnost*, vol. 14, *Izd. Mashinostroenie*.
123. Schleicher, F. (1926) *Kreisplatten auf elastischer Unterlage*. Berlin: Springer-Verlag.
124. Serebrianyi, R.B. (1960) Determination of the collapse load for plates on an elastic foundation (text in Russian). *Osnovania, Fundamenty i Mekhanika Gruntov*, no. 2.
125. Sergeev, B.N. (1929) Construction of ice crossings for railroad cars and the response of the ice cover when subjected to loads (text in Russian). *Trudy Nauchno-Tekhnicheskogo Komiteta Narodnogo Komissariata Putei Soobshcheniia*, vol. 84.
126. Shapiro, G.S. (1942) Design of a plate conceived as an infinite band resting upon elastic foundation. *Comptes Rendus (Doklady) de l'Académie des Sciences de l'URSS*, no. 7-8.
127. Shapiro, G.S. (1943) Deflection of a semi-infinite plate on an elastic foundation (text in Russian). *Prikladnaia Matematika i Mekhanika*, vol. 7.
128. Sharp, R.P. (1947) Suitability of ice for aircraft landings. *Transactions of the American Geophysical Union*, vol. 28, no. 1.
129. Shekhter, O.Ja. and L.V. Vinokurova (1936) Analysis of plates on elastic foundation (text in Russian). *ONTI, Glavn. Red. Stroit. Lit.*
130. Shishov, N.D. (1947) On the strength of ice (text in Russian). *Meteorologia i Gidrologia*, no. 2.
131. Shmatkov, V.A. (1968) The deformation characteristics of the ice cover of Lake Baikal during the spring period (text in Russian). *Trudy, Gosudarstvennyi Gidrologicheskii Institut, Leningrad*, vol. 159.
132. Shulman, A.F. (1946) Calculation of the load carrying capacity of ice crossings on the basis of the theory of central flexure of an elastic plate placed on an elastic foundation (text in Russian). *Trudy Nauchno-Issledovatel'skikh Uchrezhdenii* (B.L. Lagutin, Editor), seria 5, vyp 20. Translated by U.S. Arctic Construction and Frost Effects Laboratory (USA CRREL), 1954.

133. Smirnov, V.I. (1967) On the possibility of calculating the strength limits of sea ice under loads of short duration. *Okeanologiya*. Translated in *Oceanology*, 1968.
134. Sokolnikov, N.M. (1964) Strength of ice on the Yenisei River in the region of the Krasnojarsk Power Station during the spring period (text in Russian). *Trudy Koordinacionnykh Soveshchenii po Gidrotekhnike*, vyp. X.
135. Stearns, S.R. (1957) Aircraft operations on floating ice sheets. *Proc. ASCE, Journal of the Air Transport Division*.
136. Stevens, H.W. and W.J. Tizzard (1969) Traffic tests on Portage Lake ice. USA CRREL Technical Report 99. AD 700130.
137. Sundberg-Falkenmark, M. (1963) The load bearing capacity of ice (text in Swedish). The Swedish Institute of Meteorology and Hydrology, Stockholm.
138. Tabata, T., K. Fujino and M. Aota (1967) Studies of the mechanical properties of sea ice XI. The flexural strength of sea ice in situ. In *Physics of Snow and Ice* (H. Oura, Editor), Institute of Low Temperature Science, Hokkaido University, Japan.
139. Tauriainen, M.J. (1970) Port Clarence sea ice testing. *Northern Engineer*, vol. 2, no. 1.
140. The bearing capacity of ice covers on lakes (text in Polish) (1968) *Drogownictwo*, vol. 23, no. 9.
141. Timoshenko, S. (1941) *Strength of materials*, Vol. II. New York: D. Van Nostrand Co.
142. Timoshenko, S. and S. Woinowsky-Krieger (1959) *Theory of plates and shells*. New York: McGraw-Hill, second edition.
143. Vishniakov, Kh.Z. and Ju.M. Silantiev (1970) The utilization of the ice cover during construction of hydro-technical structures (text in Russian). *Transportnoe Stroitel'stvo*, no. 9.
144. Voitkovskii, K.F. (1957) Experimental investigation of the plastic properties of ice (text in Russian). *Sezonnoe Promerzanie Gruntov i Ispolzovanie Lda dlia Stroitel'nykh Celei*, Izd. An SSSR.
145. Voitkovskii, K.F. (1960) Mechanical properties of ice (text in Russian). *Izd. An SSSR*.
146. Volkov, G. (1940) Airfields on ice. *Morskoi Sbornik*, no. 3. USA ACFEL Translation 4. AD 712536.
147. Weeks, W.F. and D.L. Anderson (1958) An experimental study of strength of young sea ice. *Transactions of the American Geophysical Union*, vol. 39.
148. Weeks, W.F. and A. Assur (1967) The mechanical properties of sea ice. USA CRREL Cold Regions Science and Engineering Monograph II-C3. AD 662716.
149. Weeks, W.F. and A. Assur (1969) Fracture of lake and sea ice. USA CRREL Research Report 269. AD 697750.
150. Weeks, W.F. and A. Kovacs (1970) On pressure ridges. USA CRREL.
151. Westergaard, H.M. (1923) Om Beregning af Plader paa elastisk Underlag med saerligt Henblik paa spørgsmaalet om Spaendinger i Betonveje. *Ingeniøren*, Kopenhagen, no. 42.

152. Westergaard, H.M. (1948) New formulas for stresses in concrete pavements of air-fields. *Transactions ASCE*.
153. Wyman, M. (1950) Deflections of an infinite plate. *Canadian Journal of Research*, vol. A28.
154. Zubov, N.N. (1942) The basis of road construction on the ice cover (text in Russian). *Gidrometeoizdat, Moscow*.
155. Zubov, N.N. (1945) Ice of the Arctic (text in Russian). *Moscow*.
156. Zvolinskii, N.V. (1946) On the problem of deformation of floatice ice layers (text in Russian). *Trudy Nauchno-Issledovatel'skikh Uchrezhdenii* (B.L. Lagutin, Editor), seria 5, vyp. 20, Sverdlovsk, Moscow. Translated by USA ACFEL, 1954.
157. Zylev, B.V. (1950) Ice pressure upon inclined ice breakers (text in Russian). *Trudy Moskovskogo Ordena Lenina Instituta Inzhenerov Zhelezodorozhnogo Transporta*, vol. 74.