

## The Concept of Automatic Transport System Utilizing Weight Sensor

Yurni Oktarina, Tresna Dewi\*, Pola Risma

*Department of Electrical Engineering, Politeknik Negeri Sriwijaya*

*\*tresna\_dewi@polsri.ac.id*

### ABSTRACT

The current pandemic situation insists that people find a way to create a physical distance, limiting the number of people in a closed room. The human need for commuting has led to the idea of an automatic transport system that can transport people and goods without the assistance of a driver. This idea can lead to a new "normal" and reduced cost of manufacturing in the industry. The paper discussed the concept of an automatic transport system using a weight sensor. An automatic vehicle is designed to transport loads of different packages and be allocated automatically based on the weight of the package. The system is designed to be as simple as possible to increase the scope for implementation.

**Keywords:** Automatic Transport Vehicle, Line Sensor, Pandemic Solution, Weight Sensor.

### 1. INTRODUCTION

Nowadays, the pandemic condition insists that people seek a method to distance themselves from society and use machines more for sectors that do not require human involvement. Automation has been the answer for many years to help people avoid danger, dullness, dirt, and hardship. Therefore, automation is fit with the idea of physical distancing. Automation has started from manufacturing lines, and has now moved to most human lifestyles, including domestic ones. People's life always involves moving or commuting to work or anywhere. The current pandemic issue is how to reduce the number of people in a closed room. It will, therefore, be better to have fewer humans inside the transport system. Without mentioning that driving from one place to another fixed destination hardly requires human involvement. The driver's job can be assigned to an automatic system. This idea leads to an automated transport system for the transport of people or goods [1][2].

The idea of having a self-propelled bus or truck that drives people to a car instead of a human drive could be a reality in today's technology. The first application may be for the industry to drive or transport from one point to another of the manufacturing lines [3]. This autonomous transport system would be more advantageous than the use of human drivers with their limitations. Autonomous technology has the potential to help increase the productivity of the production line and reduce transport costs.

Technology companies such as Apple, Intel, Amazon, and Aptiv have developed automatic vehicle support sensors, gadgets, and related technologies. Not to mention car companies such as Audi, Daimler AG, and BMW have tested their autonomous vehicles on public roads. The sensor, such as LiDAR and perception sensor

software, was roaming the market and used by Volvo and Toyota to ensure automatic street safety in the event of no crash [4]-[10].

Such technologies seem costly, and what if automated vehicle and transportation system for tram-like vehicle drives on its line can be constructed simpler? The automatic vehicle can be equipped with a weight sensor to know how much weight it is loaded and how many people are aboard. Time delay can be installed to make it stop at the station for some time.

This paper discusses the concept of an automatic vehicle by using a weight sensor to inform the vehicle of the goods loaded. The prototype is equipped with time delay and move in the production line scenario. The vehicle moves from one station to another, imitating the transportation system in the factory.

## 2. AUTOMATIC VEHICLE DESIGN

The automatic vehicle design proposed in this study is shown in Figure 1, where the design kept simple, employing two sensors, weight, and line sensor. The concept of line follower robot is developed into this automatic transport system. The line sensor is built from photodiode that can differentiate between dark and bright; therefore, the vehicle stays on the line. The line sensor is used to detect the color of the surface under the vehicle; therefore, the line sensor can produce the vehicle's position logic. The positioning logic generated by this line sensor is used as an input to the microcontroller. A line sensor consists of a photodiode as light receivers and LEDs as light transmitters.

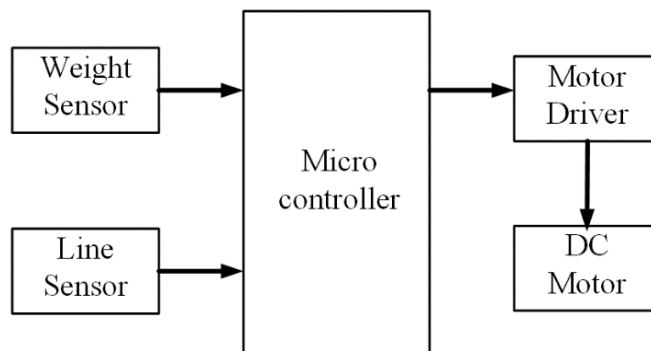

FIGURE 1. Block Diagram of Automatic Vehicle Design.

The main controller is ATmega 2560, built inside the Arduino Mega 2560 that receives the input to govern the vehicle motion. The DC motor is driven by Motor DC Driver L298N. The L298N DC motor driver has 2 H-Bridge circuits within the H-Bridge IC system that can be used to drive two DC motors. H-Bridge DC motor drivers L298N can deliver currents up to 1A each. However, in its use, the H-Bridge DC motor driver L298N can be used in parallel, so that the power to deliver the H-Bridge DC motor driver L298N should be 2A. IC L298N's has four input channels, which can accommodate TTL logical inputs. Every of these input channels has an output. The complete electrical circuit is shown in Figure 2.

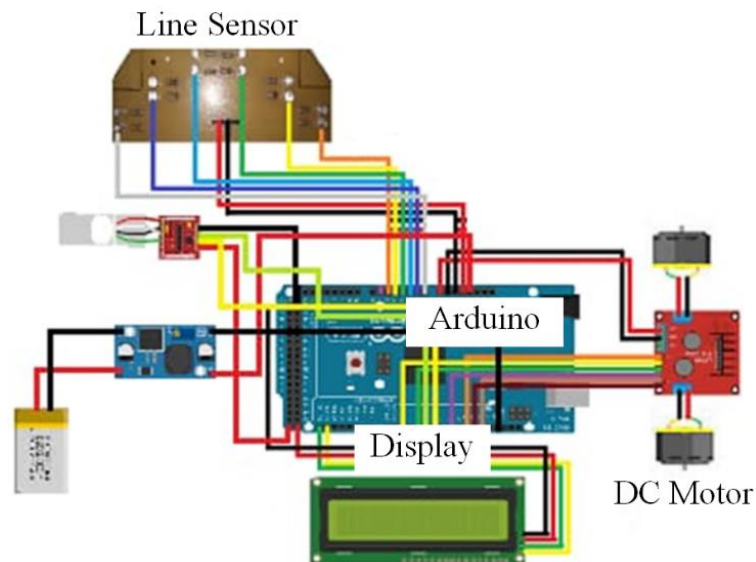

FIGURE 2. The Electrical Circuit of Automatic Vehicle Design

### 3. WEIGHT SENSOR UTILIZATION

The Weight Sensor is a sensor used to detect the pressure or weight of the load. The weight sensor used in this study is a Load Cell Sensor that is commonly used as the main component of a digital weighing system. The load cell shall be used on the weighbridge to determine the weight of a vehicle or a transport truck. The pressure principle is applied to the measurements made by this sensor. The load cell sensor applied to this study has the maximum working capacity of 2 kg, low voltage operation 5-10 V<sub>DC</sub> or 5-10 V<sub>AC</sub>, small and practical size, low resistance on input or output, 0.05% of non-linearity, and working temperature range -10°C to +50 °C.

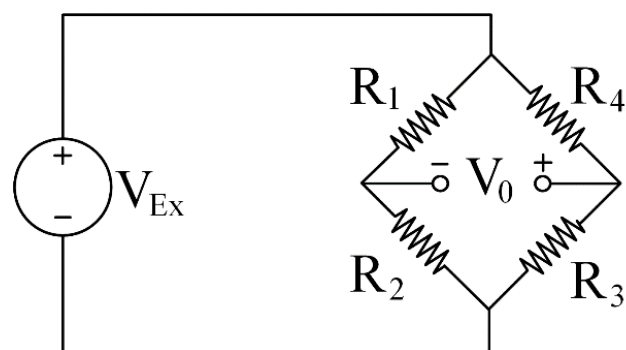

FIGURE 3. The Modeling of The Weight Sensor Applied in This Study.

The weight sensor converts forces such as pressure, tension, and compression into the electrical signal received by the controller, and display the result of measurement to the display, as shown in Figure 1. Figure 3 shows the modeling of the weight sensor applied in this study, where  $V_{Exc}$  is the excitation voltage, which is

constant,  $V_0$  is the output voltage,  $R_1$  and  $R_3$  are tension strain gauge, and  $R_2$  and  $R_4$  are compression strain gauge.

If  $R_1$  to  $R_4$  in Figure 3 are balanced,  $\frac{R_1}{R_2} = \frac{R_4}{R_3}$ , then  $V_0$  is zero. Therefore, if there are changes in  $R_1$  to  $R_4$ , then  $V_0$  changes respectively. The changes in  $V_0$  is measured by using Ohm's Law,  $I = \frac{V}{R}$ . Hence, based Wheatstone bridge configuration in Figure 3, the voltage output is given by

$$V_0 = \left( \frac{R_3}{R_3+R_4} - \frac{R_1}{R_1+R_2} \right) V_{Ex}. \quad (1)$$

## 4. RESULT AND DISCUSSION

This study proposes an automatic transport system concept as one of the ways to improve efficiency in industry and daily human life, and also as the way to conduct the new normal of social distancing by reducing the number of people inside a closed room, such a vehicle. The considered research is how to create an automatic vehicle with as simple as a possible concept.

### 4.1 EXPERIMENTAL SETUP

Figure 4 shows the designed vehicle considered in this study. The vehicle is equipped with a loading tray to transport the load from the assigned points. Line sensors are assigned to read the track shown in Figure 5, and the weight sensor is used to detect the weight attached to the robot to determine the destination.

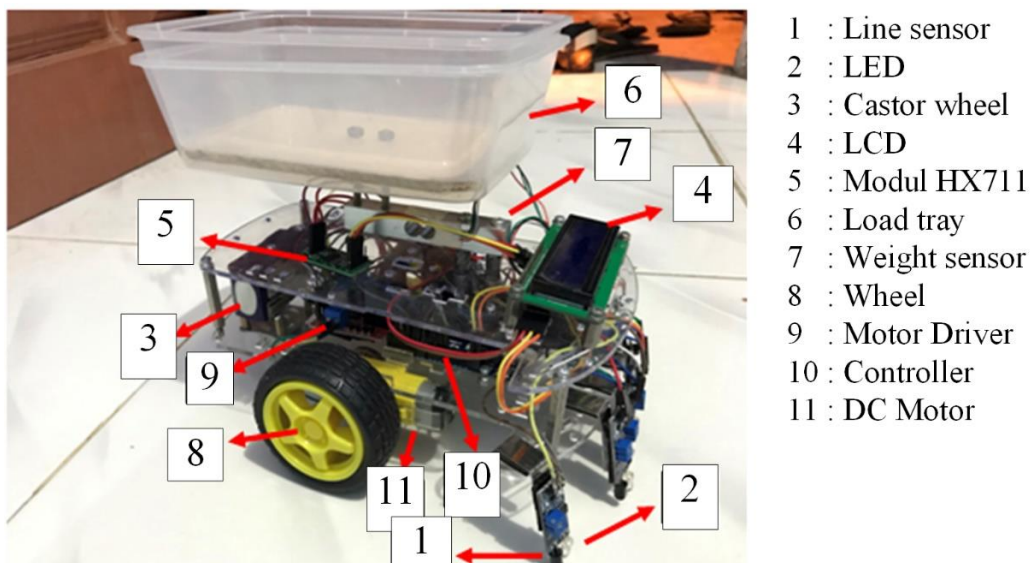

FIGURE 4. The Automatic Vehicle Design.

The prototype of a vehicle is a robot transporting goods based on the weight parameters carried. A weight sensor or load cell is mounted under the robot cross-section, while a load tray is mounted at the top of the robot cross-section, as shown in Figure 3. Thus, when the load is placed on top, the load cell reads the weight of the shipment carried by the robot and displays it on the LCD (Liquid Crystal Display). Then the pressure that was read was entered into the controller. The controller shall decide the assigned destination based on the weight of the load.

Figure 5 shows the track to the effectiveness of the proposed method. The track length from start to point C is 170 cm (only straight), 55cm (turn left) from the intersection to point A, and 55cm (turn right) from the intersection of point B. The destination of the vehicle shall be decided based on the weight of the load carried. If the vehicle is mounted an amount of 50-150 grams, the robot goes to point A, and if the vehicle is given a weight of 250-350 grams, the robot goes to point B while transporting a pack of 150-250 grams, the robot goes to point C.

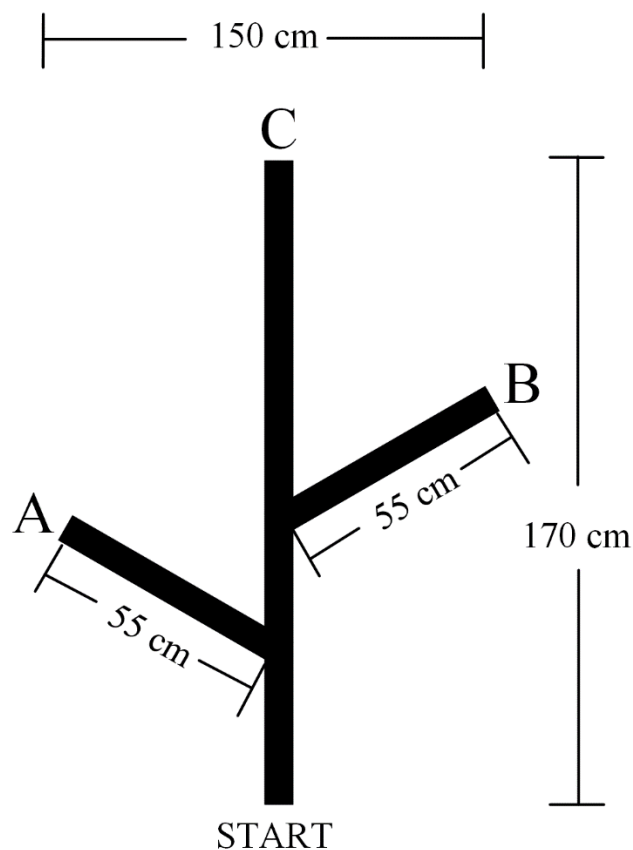

FIGURE 5. The Assigned Track.

## 4.2 EXPERIMENTAL SETUP

The automatic vehicle is assigned to carry a packet from start to point A, B, and C shown by Figure 5, to show the effectiveness of the proposed method. The vehicle



decides the destination automatically based on the packet mounted on the loading tray, shown in Figure 4. The vehicle moves the package from start to point (A, B, or C), and, as the package is unloaded, the vehicle returns to the starting point and is ready for the next task. Figure 6 shows the screenshots of the robot transporting the load from point to point.

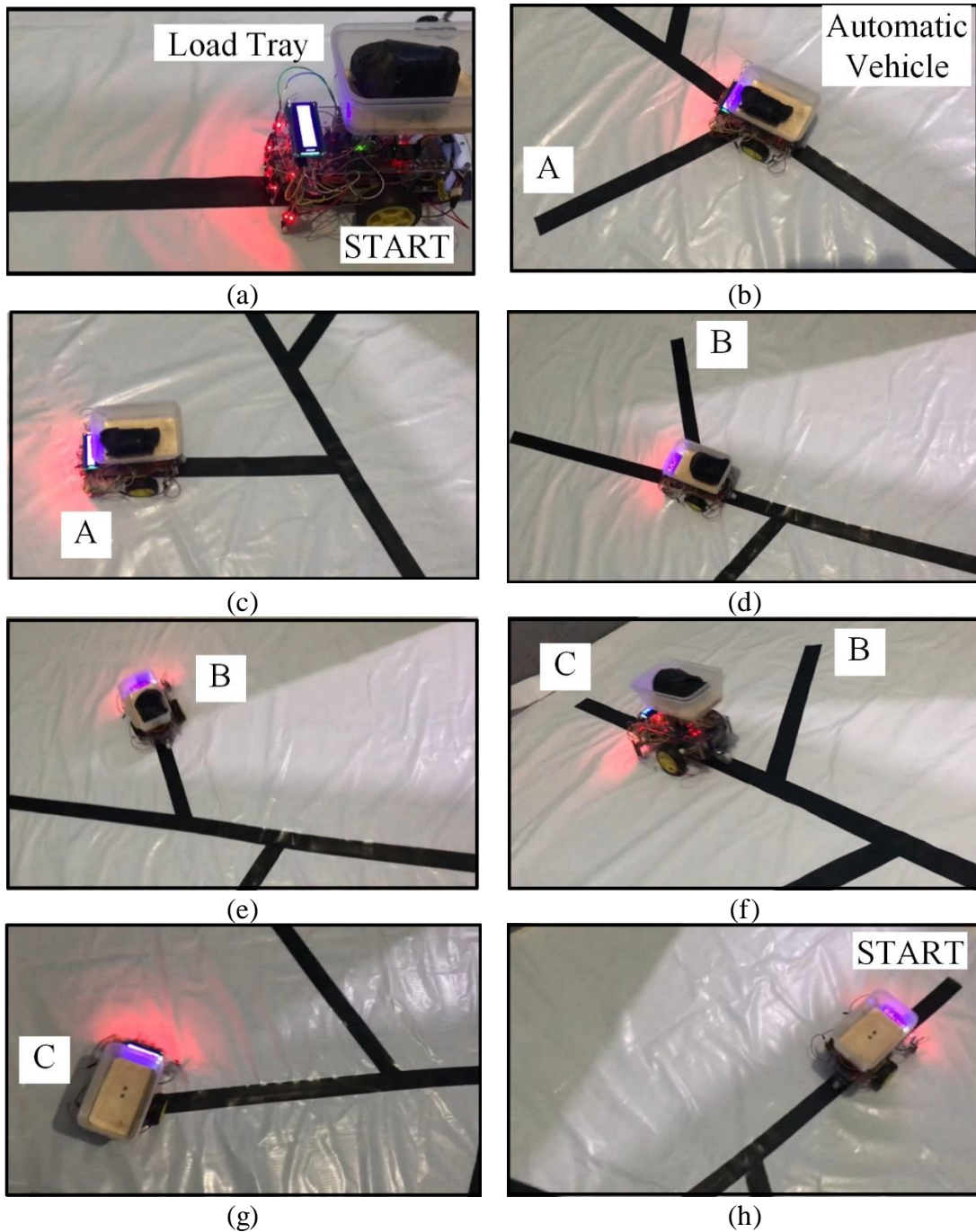

FIGURE 6. Proposed automatic transport system.

Figure 6a shows the vehicle in starting position and transport a 118.31 grams package; therefore, it moves to point A (Figure 6b and 6c). Figure 6d robot delivers a 264.47 grams package to point B. Figure 6f and 6g show the robot transport the package (150-250 grams) to point C and returns to the starting point in Figure 6h.

Table 1 shows the relationship among line sensors, motor speed, and vehicle direction as it delivers the package to assigned points. Table 2 shows the difference scaling between the weight sensor applied in this study and the conventional scaling device.

TABLE 1.  
The Relationship of Line Sensors, Motor Speed and Vehicle Direction

Motor Speed (RPM)		Line Sensors						Robot Direction
Left	Right	1	2	3	4	5	6	
30	90	1	0	0	0	0	0	Forward
50	70	0	1	0	0	0	0	Forward
70	50	0	0	1	0	0	0	Forward
90	30	0	0	0	1	0	0	Forward
50	70	1	1	0	0	0	0	Forward
70	70	0	1	1	0	0	0	Forward
70	50	0	0	1	1	0	0	Forward
40	70	1	1	1	0	0	0	Forward
70	40	0	1	1	1	0	0	Forward
90	0	1	1	1	1	0	0	Forward
20	90	0	0	0	0	1	0	Turn right
90	20	0	0	0	0	0	1	Turn Left

TABLE 2.  
Load Cell Scaling Comparison to The Conventional Machine

Load Cell Scaling (gram)	Conventional Weight Machine Scaling (gram)	Difference (gram) (%)	
98.725	100	1.275	1.29%
99.239	100	0.761	0.77%
98.092	100	1.908	1.95%
200.344	200	0.344	0.17%
200.843	200	0.843	0.42%
199.238	200	0.238	0.12%
298.381	300	1.381	0.46%
300.137	300	0.137	0.05%
299.924	300	0.924	0.31%

TABLE 3.  
 Load Weight and The Assigned Destinations

Load Weight	Destination A 50-150 gram	Destination B 250-350 gam	Destination C 150-250 gram	Result
100	✓	-	-	Succeed
90	-	-	✓	Fail
60	-	-	✓	Fail
170	-	-	✓	Succeed
200	-	-	✓	Succeed
230	-	-	✓	Succeed
260	-	✓	-	Succeed
280	-	✓	-	Succeed
300	-	✓	-	Succeed

The vehicle was tested to deliver a load in various weight to be delivered automatically to the point A, B, or C. Table 3 shows that when the weight is less than 100 grams, the input to the controller seems not right and resulted to the packages delivered to the wrong destination. However, when the package is more than 100 grams, the vehicle can automatically deliver the package to the assigned destination.

## 5. CONCLUSION

This study discusses the concept of an automatic transport system when the vehicle delivers the package to its destination based on the weight of the package. This concept is useful in reducing human involvement in the transportation and commuting system in line with the current pandemic situation. The vehicle was tested to deliver different packages and 100 percent accurate when the package was more than 100 grams.

## REFERENCES

- [1]. D. Christie, A. Koymans, T. Chanard, J. M. Lasgouttes, and V. Kaufmann, "Pioneering driverless electric vehicle in Europe: the city automated transport systems (CATS)," in *Proceeding of European Transport Conference 2015*, Transportation Research Procedia, Vol. 13, pp 30-39, 2016.
- [2]. S. Shin, H.S. Roh, and S.H. Hur, "Technical trends related to intermodal automated freight transport system (AFTS)," *The Asian Journal of Shipping and Logistic*, Vol. 3, No. 2, pp. 161-169, 2018.
- [3]. P. Moriarty, and S. J. Wang, "Could automated vehicle reduce transport energy? 9<sup>th</sup> International Conference on Applied Energy," *ICAE2017, Energy Procedia*, Vol. 142, pp. 2109-2113, 2017.
- [4]. W. Cao and M. Zhang, "The Optimization and Scheduling Research of Shuttle Combined Vehicles in Automated Automatic Three-dimensional Warehouse," *Procedia Engineering*, Vol. 174, pp. 579-587, 2019.



- [5]. A. Nguyen, P. Chevrel, and F. Claveau, "On the Effective Use of Vehicle Sensors for Automatic Lane Keeping via LPV Static Output Feedback Control," *IFAC-PapersOnline*, Vol. 50, No. 1, pp. 13808-13815, 2017.
- [6]. T. Dewi, P. Risma, Y. Oktarina, A. Taqwa, Rusdianasari, and H. Renaldi, "Experimental analysis on solar powered mobile robot as the prototype for environmentally friendly automated transportation," in *Proceeding of Journal of Physics: Conference Series, International Conference on Applied Science and Technology (iCAST on Engineering Science) 24–25 October 2019, Bali, Indonesia*, Vol. 1450, 2019.
- [7]. T. Dewi, P. Risma, and Y. Oktarina, "Wedge formation control of swarm robots," in *Proceeding of the 14th industrial electronics seminar, electronic engineering polytechnic institute of Surabaya (EEPIS), Indonesia*, pp. 294-298, 2012.
- [8]. N. Uchiyama, T. Dewi, and S. Sano, "Collision avoidance control for a human-operated four-wheeled mobile robot," *Proceedings of the Institution of Mechanical Engineers, Part C: Journal of Mechanical Engineering Science*, SAGE Publication, Vol. 228, No. 13, pp. 2278-2284, 2014.
- [9]. T. Dewi, N. Uchiyama, S. Sano, and H. Takahashi, "Swarm robot control for human services and moving rehabilitation by sensor fusion," *Journal of Robotics*, 2014.
- [10]. S. Gelmini, S. Strada, M. Tanelli, S. Savaresi, and C. De Tommasi, "Automatic crash system for two-wheeled vehicles: design and experimental validation," *IFAC-PapersOnline*, Vol. 52, No. 5, pp. 498-503, 2019.