

## THE CONVERSE TO THE GAUSS-BONNET THEOREM IN PL

HERMAN GLUCK, KENNETH KRIGELMAN & DAVID SINGER

If  $M$  is a compact two-dimensional Riemannian manifold, possibly with boundary, the Gauss-Bonnet theorem [7], [5], [6], [16] asserts:

$$\int_M \text{curvature} + \int_{\partial M} \text{geodesic curvature} + \sum_{\partial M} \text{exterior angles} = 2\pi\chi(M),$$

where  $\chi(M)$  is the Euler characteristic of  $M$ , and it is natural to ask if this is the only relation among these quantities. In this paper we show that in the piecewise linear category, the condition is indeed sufficient.

### 1. History of the problem

Consider first the smooth category. Here the question for closed manifolds has received a flurry of attention during the past few years, though in some aspects it traces back to the work of Minkowski [17], [18] in 1897.

Suppose that a closed smooth two-manifold  $M$  and a smooth real-valued function  $K: M \rightarrow \mathbf{R}$  are given, and that one is asked to find a Riemannian metric for  $M$  having  $K$  as its Gaussian curvature. Note that the Gauss-Bonnet "condition" on  $K$  cannot be formulated in advance, since there is no area element given on  $M$ . Nevertheless, some restrictions are imposed. If  $M$  has positive Euler characteristic, i.e., if  $M$  is the sphere or projective plane, then the preassigned function  $K$  must certainly be somewhere positive on  $M$ . If  $\chi(M) = 0$ , i.e., if  $M$  is the torus or Klein bottle, then  $K$ , if not identically 0, must be somewhere positive and somewhere negative. If  $\chi(M)$  is negative, then  $K$  must be somewhere negative. With these restrictions on  $K$ , the problem has been completely solved for all closed smooth two-manifolds by:

Melvyn Berger [4] for orientable manifolds of negative Euler characteristic, provided  $K < 0$  everywhere;

Gluck [8], [9] for the two-sphere provided  $K > 0$  everywhere;

Moser [19] for the projective plane;

Kazdan and Warner [10], [11], [12], [13], [14] in all other cases.

Recently Kazdan and Warner have obtained a uniform solution. The problem

---

Received July 16, 1973. The first author was supported by National Science Foundation Grant No. 29258 and a Guggenheim Fellowship, and the last author by National Science Foundation Grant No. 33960X.

for compact two-manifolds with boundary, however, seems not yet to have been addressed in the smooth category.

In the PL category, the problem takes on a somewhat different aspect. First, curvature here is the analogue of integral curvature for smooth manifolds, so the Gauss-Bonnet theorem can be imposed undiluted as a necessary condition. Second, the problem has a combinatorial character which submits to methods entirely different from those used in the smooth case. The converse to the PL Gauss-Bonnet theorem was observed for the two-sphere by D. Singer (unpublished) provided the curvature is everywhere nonnegative; for the general case of the two-sphere by Gluck (unpublished); and proved for all closed two-manifolds by Krigelman [15].

We give next some general information about PL Riemannian metrics for PL manifolds in general and then especially for two-manifolds, before formulating and proving the converse to the Gauss-Bonnet theorem for compact PL two-manifolds with boundary.

## 2. PL Riemannian metrics

A good background reference for some of the following is Alexandrov [1].

By a *polyhedron*  $X$  we mean a topological space homeomorphic to the underlying space of some locally finite simplicial complex, together with a maximal family of PL equivalent triangulations of  $X$ . A piecewise linear map  $f: X_1 \rightarrow X_2$  between polyhedra is said to be *nondegenerate* if  $f$  is injective on each simplex for some triangulation of  $X_1$ .

A metric (ordinary distance function) on a simplex  $\sigma$  is *linear* if it agrees with the metric induced by some linear embedding of  $\sigma$  into a Euclidean space. A *metric simplicial complex* consists of the following data:

- (1) a locally finite simplicial complex  $K$ ,
- (2) a collection  $\{d_\sigma: \sigma \in K\}$  of linear metrics on the simplices of  $K$ , subject to the consistency requirement that if  $\sigma$  is a face of  $\tau$  then the metric  $d_\sigma$  on  $\sigma$  is the restriction to  $\sigma$  of the metric  $d_\tau$  on  $\tau$ .

A map  $i: K' \rightarrow K$  of metric simplicial complexes is a *subdivision* if:

- (a)  $i$  is a homeomorphism, linear on each simplex of  $K'$ , and
- (b)  $d_{\sigma'} = d_\sigma \circ (i \times i)$  for any simplex  $\sigma'$  of  $K'$  mapping into a simplex  $\sigma$  of  $K$ .

If  $T: K \rightarrow X$  is a triangulation of  $X$ , and  $K$  is a metric simplicial complex, then  $T$  is referred to as a *presentation of a Riemannian metric on  $X$* . The operation of subdivision for metric simplicial complexes generates an equivalence relation among the presentations of Riemannian metrics on a fixed polyhedron  $X$ . A corresponding equivalence class will be called a *Riemannian metric on  $X$* ;  $X$  together with such a Riemannian metric will be called a *Riemannian polyhedron*.

If  $f: X_1 \rightarrow X_2$  is a nondegenerate map, then a Riemannian metric on  $X_2$

may be pulled back via  $f$  to one on  $X_1$ . For example, a subpolyhedron of any Riemannian polyhedron becomes a Riemannian polyhedron via the inclusion map. Thus the subpolyhedra of Euclidean space, for example, become Riemannian polyhedra in the obvious way.

The elementary geometry of Riemannian polyhedra unfolds in a manner similar to that for smooth Riemannian manifolds. For example, a Riemannian metric on the polyhedron  $X$  may be used to define the notion of path length, from which we derive the *induced metric* (ordinary distance function)  $d_X$  on  $X$ . It is easy to check that the corresponding metric topology on  $X$  agrees with its usual (weak) topology as a polyhedron. A Riemannian polyhedron is *complete* if the induced metric is a complete metric.

If  $Y$  is a subpolyhedron of a Riemannian polyhedron  $X$ , we can compare the induced metric  $d_Y$  on  $Y$  with the restriction of  $d_X$ . In general  $d_Y(p, q) \geq d_X(p, q)$ ; if they are identically equal we say  $Y$  is *totally geodesic* in  $X$ .

We offer the following facts as orientation to the reader. They will not be used in the present paper, so proofs are omitted.

(1) Every Riemannian polyhedron has a triangulation, each of whose simplexes is totally geodesic.

(2) Shortest paths between points in a Riemannian polyhedron, if they exist, are always PL. In the complete case, they always exist.

(3) In a complete Riemannian polyhedron, every closed and bounded subset is compact.

(4) A Riemannian metric on a subpolyhedron  $Y \subset X$  can always be extended to one on  $X$ ; if  $Y$  is complete,  $X$  can be chosen to be complete. In either case, we can make  $Y$  totally geodesic in  $X$ .

(5) Any point of a Riemannian polyhedron  $X$  has a neighborhood  $U$  which is convex in the following sense: Between any two points of  $U$  there exists a shortest path (in general not unique), and all such shortest paths run entirely in  $U$ .

An *isometric map*  $f: X \rightarrow Y$  between Riemannian polyhedra is a nondegenerate PL map such that the metric on  $X$  agrees with the pullback via  $f$  of the metric on  $Y$ . An *isometry* is an isometric homeomorphism, or equivalently, an isometry with respect to the induced metrics  $d_X$  and  $d_Y$ .

The following construction will be used repeatedly in our arguments. Let  $Y_1$  and  $Y_2$  be disjoint subpolyhedra of the Riemannian polyhedron  $X$ , and let  $h: Y_1 \rightarrow Y_2$  be an isometry. Then the quotient space  $X/h$ , in which each point of  $Y_1$  is identified with its image under  $h$  in  $Y_2$ , becomes a Riemannian polyhedron in a natural way such that the natural projection map  $\pi: X \rightarrow X/h$  is isometric. In fact, suppose the triangulation  $T: K \rightarrow X$  is a presentation of the Riemannian metric on  $X$ , such that

- (1)  $Y_1$  and  $Y_2$  appear as subcomplexes,
- (2)  $h: Y_1 \rightarrow Y_2$  is simplicial,
- (3) the resulting cell structure on  $X/h$  is that of a simplicial complex.

Such triangulations are easily obtained: If  $T'$  is any presentation of the Riemannian metric on  $X$ , we may subdivide so that (1) is satisfied. Subdivide further so that  $h$  is simplicial; then (2) will be satisfied. Passing to the second barycentric subdivision, (3) will be satisfied as well. The resulting triangulation of  $X/h$  by a metric simplicial complex exhibits the Riemannian structure on  $X/h$ , which is easily seen to be independent of the particular triangulation  $T$  of  $X$ .

A special case of this construction occurs when  $h: Y_1 \rightarrow Y_2$  is an isometry between subpolyhedra of disjoint Riemannian polyhedra  $X_1$  and  $X_2$ ; we simply regard  $X = X_1 \cup X_2$ . A further specialization occurs when  $X_1$  and  $X_2$  are disjoint copies of the same Riemannian polyhedron  $X$ ,  $Y_1$  and  $Y_2$  are the corresponding copies of the same subpolyhedron  $Y$ , and  $h: Y_1 \rightarrow Y_2$  is the "identity". Both of these cases occur frequently in what follows.

### 3. Curvature of PL two-manifolds

Good background references for the next two sections are Banchoff [2], [3].

Suppose now that  $M$  is a PL Riemannian two-manifold (possibly with boundary). For any point  $p$  of  $M$ , let  $a(p)$  denote the sum of the angles around  $p$ ; this is independent of the presentation used to compute it.

If  $p$  is an interior point of  $M$ , the *curvature* at  $p$  is defined to be  $k(p) = 2\pi - a(p)$ , a real number less than  $2\pi$ . The rationale for this definition comes from the case of a convex polyhedral surface  $M$  in  $\mathbf{R}^3$ . Here this intrinsic definition coincides with the extrinsic definition of curvature at  $p$  as the area of the "spherical image" of  $p$ , that is, the area of the set on  $S^2$  of unit outward normal vectors to support planes of  $M$  at  $p$ , thus paralleling the smooth case.

If  $q$  is a boundary point of  $M$ , the *exterior angle* at  $q$  is defined to be  $e(q) = \pi - a(q)$ , a real number less than  $\pi$ .

Notice that if  $T: K \rightarrow M$  is a presentation of the Riemannian metric on  $M$ , then nonzero curvatures and exterior angles can occur only at the vertices of this triangulation. Interior (boundary) points of  $M$  at which the curvature (exterior angle) is zero are said to be *flat*.

Note also that if we change the scale on a PL Riemannian two-manifold by multiplying all linear dimensions by a fixed positive constant, then angles in simplices remain unchanged, and hence so do all curvatures and exterior angles. This reflects the fact that integral curvature in the smooth category is also unaffected by a change of scale.

The pasting operation  $X \rightarrow X/h$  described in the preceding section will be applied to two-manifolds  $M$  as follows. Let  $Y_1$  and  $Y_2$  be disjoint subpolyhedra on  $\partial M$ , and  $h: Y_1 \rightarrow Y_2$  an isometry. If we assume that each of  $Y_1$  and  $Y_2$  is a finite disjoint union of arcs and simple closed curves (thus eliminating the possibility of isolated vertices), we can conclude that  $M/h$  is itself a two-manifold.

An interior point of  $M$  goes to an interior point of  $M/h$  with the same curvature. A point of  $\partial M - (Y_1 \cup Y_2)$  goes to a boundary point of  $M/h$  with the same exterior angle. Finally, let  $q_1 \in Y_1$  and  $q_2 = h(q_1) \in Y_2$  with exterior angles  $e_1$  and  $e_2$ , and let  $q$  be the class of  $q_1$  in  $M/h$ . We compute the curvature (or exterior angle) at  $q$  as follows:

If  $q_1 \in \partial Y_1$ , that is, if  $q_1$  is an endpoint of an arc in  $Y_1$ , then  $q$  is in  $\partial(M/h)$  and

$$\begin{aligned} e(q) &= \pi - a(q) = \pi - a(q_1) - a(q_2) \\ &= \pi - a(q_1) + \pi - a(q_2) - \pi = e_1 + e_2 - \pi . \end{aligned}$$

Otherwise,  $q$  lies in the interior of  $M/h$  with curvature

$$k(q) = 2\pi - a(q) = \pi - a(q_1) + \pi - a(q_2) = e_1 + e_2 .$$

These constructions are illustrated in Fig. 1a and Fig. 1b respectively.

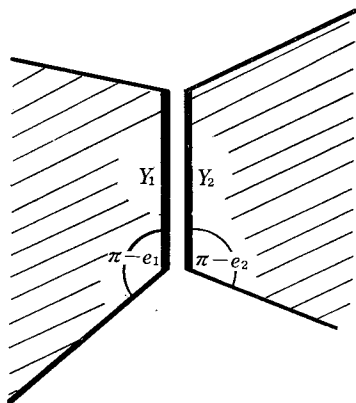

Fig. 1a

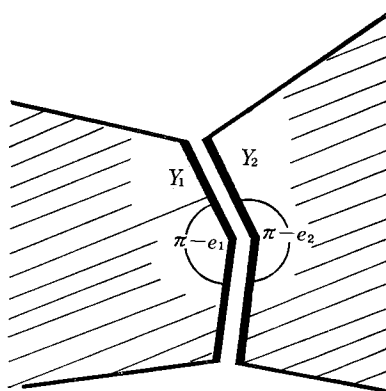

Fig. 1b

A word of explanation is in order concerning diagrams. When a diagram shows a boundary arc as a straight line segment, this certifies only that the manifold is flat at each interior point of the arc. Furthermore, although the objects are pictured in the plane, they will in general only be assumed to exist *in abstracto*, and the identifications pictured, for example, in Fig. 1 represent the quotient operation  $X \rightarrow X/h$ .

#### 4. The Gauss-Bonnet theorem and its converse

**Gauss-Bonnet theorem.** *Let  $M$  be a compact PL Riemannian two-manifold. Let  $k(p)$ ,  $p \in \overset{\circ}{M}$ , denote the curvature at an interior point  $p$  of  $M$ , and  $e(q)$ ,  $q \in \partial M$ , the exterior angle at a boundary point  $q$  of  $M$ . Then*

$$\sum_{p \in \overset{\circ}{M}} k(p) + \sum_{q \in \partial M} e(q) = 2\pi\chi(M) ,$$

where  $\chi(M)$  is the Euler characteristic of  $M$ .

*Proof.* Well known, as follows. Consider first the case that  $M$  is closed, and let  $T: K \rightarrow M$  be a presentation of the Riemannian metric on  $M$ . Suppose that  $K$  has  $V$  vertices,  $E$  edges and  $F$  faces. Observe that  $3F = 2E$ .

Let  $k_i$  be the curvature at the  $i$ -th vertex of  $K$ , and  $\alpha_{ij}$  a typical angle of a triangle at that vertex. Then

$$\begin{aligned} \sum_{p \in \overset{\circ}{M}} k(p) &= \sum_{i=1}^V k_i = \sum_{i=1}^V \left( 2\pi - \sum_j \alpha_{ij} \right) = 2\pi V - \pi F \\ &= 2\pi(V - \frac{3}{2}F + F) = 2\pi(V - E + F) = 2\pi\chi(M) . \end{aligned}$$

Now suppose that  $\partial M \neq \emptyset$ , and form the double  $2M$  of  $M$  by identifying two disjoint copies of  $M$  along  $\partial M$  via the identity map. Then  $2M$  is a closed manifold, so by the first part of the proof,

$$\sum_{p \in 2M} k(p) = 2\pi\chi(2M) = 2\pi[2\chi(M) - \chi(\partial M)] = 4\pi\chi(M) .$$

On the other hand, by the remarks at the close of the last section,

$$\sum_{p \in 2M} k(p) = 2 \sum_{p \in \overset{\circ}{M}} k(p) + \sum_{q \in \partial M} 2e(q) .$$

Hence

$$\sum_{p \in \overset{\circ}{M}} k(p) + \sum_{q \in \partial M} e(q) = 2\pi\chi(M) .$$

The object of this paper is to prove the

**Converse to the Gauss-Bonnet theorem.** *Let  $M$  be a connected compact PL two-manifold,  $p_1, \dots, p_r$  points of  $\overset{\circ}{M}$ , and  $q_1, \dots, q_s$  points of  $\partial M$ . Let  $k_1, \dots, k_r$  and  $e_1, \dots, e_s$  be real numbers such that*

- (1)  $k_i < 2\pi$  for all  $i$ ,
- (2)  $e_j < \pi$  for all  $j$ ,
- (3)  $\sum_{i=1}^r k_i + \sum_{j=1}^s e_j = 2\pi\chi(M)$ .

*Then there exists a PL Riemannian metric on  $M$  which has curvatures  $k_i$  at the points  $p_i$  and exterior angles  $e_j$  at the points  $q_j$  and is flat elsewhere.*

The proof, which occupies the rest of this paper, will consist in the construction of a PL Riemannian manifold  $M'$  homeomorphic to  $M$ , with interior points  $p'_1, \dots, p'_r$  and boundary points  $q'_1, \dots, q'_s$  such that

- (a) for each boundary component  $B$  of  $M$  with points  $q_i, \dots, q_u$  in cyclic order around  $B$ , there will be a corresponding boundary component  $B'$  of  $M'$  with points  $q'_i, \dots, q'_u$  in cyclic order around  $B'$ ,

- (b) in the orientable case, the cyclic orderings around different boundary components are required to induce the same orientation of the manifold,
- (c) the curvature of  $M'$  at  $p'_i$  is  $k_i$ , and the exterior angle of  $M'$  at  $q'_j$  is  $e_j$ ,
- (d)  $M'$  is flat elsewhere.

By the homogeneity of manifolds, there will exist a homeomorphism of  $M$  onto  $M'$  taking each  $p_i$  to  $p'_i$  and each  $q_j$  to  $q'_j$ . The Riemannian metric on  $M$  obtained via pullback will then satisfy the required conditions.

### 5. Organization of the proof

The proof is subdivided into four parts. § 6 deals with the 2-disc. Using this we treat the two-sphere with holes in § 7 by induction on the number of holes. From this, the case of compact surfaces is derived for the orientable case in § 8 and for the nonorientable case in § 9.

### 6. The disc

Let real numbers  $k_1, \dots, k_r, e_1, \dots, e_s$  be given such that each  $k_i < 2\pi$ , each  $e_j < \pi$ , satisfying

$$\sum_{i=1}^r k_i + \sum_{j=1}^s e_j = 2\pi .$$

The problem is to produce a PL Riemannian 2-disc with curvatures  $k_1, \dots, k_r$  at some  $r$  interior points and exterior angles  $e_1, \dots, e_s$  at some  $s$  boundary points *in that cyclic order*, and being flat elsewhere. We first consider two special cases, and then complete the proof by an induction argument.

*Case I:*  $r = 0$ , i.e., the disc is to have flat interior. Suppose each  $e_j > 0$ . Let  $\theta_n = \sum_{j=1}^n e_j, 0 \leq n \leq s$ . In the plane  $R^2$ , construct the lines tangent to the unit circle with inclinations  $\theta_n, 0 \leq n \leq s$  ( $\theta_s = 2\pi$ , so there are  $s$  distinct lines). They determine a convex disc  $D$ , circumscribed about the unit circle, with exterior angles  $e_1, \dots, e_s$ .

The proof now proceeds by induction on  $s$ . We may assume that some  $e_j < 0$ , else the previous argument suffices. Furthermore, since  $\sum_{j=1}^s e_j = 2\pi$ , not all  $e_j$ 's are negative; so assume without loss of generality (cyclically permuting if necessary) that  $e_s < 0, e_{s-1} > 0$ . Write  $e_{s-1} = \delta_1 + \delta_2$  such that  $\delta_1, \delta_2 > 0$  and  $e_{s-2} + \delta_1 < \pi$ . Let  $e'_j = e_j, 1 \leq j \leq s-3, e'_{s-2} = e_{s-2} + \delta_1, e'_{s-1} = e_s + \delta_2$  (this is  $< \pi$  since  $e_s < 0$  and  $\delta_2 < e_{s-1} < \pi$ ).  $\sum_{j=1}^{s-1} e'_j = 2\pi$ , so by induction there is a disc  $D'$  with exterior angles  $e'_j$  at points  $q'_j, 1 \leq j \leq s-1$ . Let  $ABC$  be a triangle with  $\sphericalangle A = \delta_1, \sphericalangle B = \delta_2, \sphericalangle C = \pi - e_{s-1}$ , and the length of side  $AB$  equal to the length of the flat boundary arc from  $q'_{s-2}$  to  $q'_{s-1}$ . Identifying these two edges (Fig. 2) gives the desired disc  $D$ . This completes Case I.

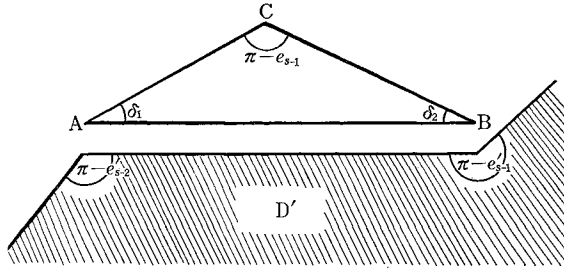

Fig. 2

Case II:  $r > 0, e_i > 0$  for all  $i$ . Suppose first, by renumbering if necessary, that  $0 < e_1 \leq e_2 \leq \dots \leq e_s < \pi$ . We construct a disc with these exterior angles (perhaps in the wrong order) and then give an easy construction for rectifying the order. Let  $\varepsilon_0 = \frac{1}{2}\pi, \varepsilon_h = \sum_0^{h-1} (-1)^i e_{h-i}$  for  $1 \leq h \leq s - 1, 2\varepsilon_s = \sum_0^{s-1} (-1)^i e_{s-i} + \pi, \varepsilon_{s+i} = \frac{1}{2}k_i$  for  $1 \leq i \leq r$ . This definition is motivated as follows:  $\varepsilon_1 = e_1, \varepsilon_1 + \varepsilon_2 = e_2$ , and in general  $\varepsilon_{j-1} + \varepsilon_j = e_j$  for  $2 \leq j < s$ . Finally,  $\varepsilon_{s-1} + 2\varepsilon_s - \pi = e_s$ . Therefore

$$\begin{aligned} \sum_0^{s+r} \varepsilon_j &= \varepsilon_0 + \sum_1^s \varepsilon_j + \sum_{s+1}^r \varepsilon_j \\ &= \frac{1}{2}\pi + \frac{1}{2} \left[ \varepsilon_1 + \left( \sum_1^{s-2} \varepsilon_j + \varepsilon_{j+1} \right) + \varepsilon_{s-1} + 2\varepsilon_s \right] + \frac{1}{2}(k_1 + \dots + k_r) \\ &= \frac{1}{2}\pi + \frac{1}{2} \left( \sum_1^s e_j + \pi \right) + \frac{1}{2} \sum_1^r k_i = 2\pi . \end{aligned}$$

One checks that the ordering on the  $e_j$ 's insures that  $0 \leq \varepsilon_j < \pi$  for  $j < s$  and  $\frac{1}{2}\pi \leq \varepsilon_s < \pi$ .

By Case I, there is a disc  $D'$  having points  $q_0, \dots, q_{s+r}$  on its boundary such that  $e(q_j) = \varepsilon_j$ , in that cyclic order, and being flat elsewhere (Fig. 3a). Take two copies of  $D'$  and identify along the arc from  $q_s$  to  $q_{s+r}$  to  $q_0$  (Fig. 3b). The resulting disc  $D''$  has interior curvatures  $k_1, \dots, k_r$  at points corresponding to  $q_{s+1}, \dots, q_{s+r}$  and is flat elsewhere in the interior.  $D''$  has exterior angles  $\varepsilon_1, \dots, \varepsilon_{s-1}, 2\varepsilon_s - \pi, \varepsilon_{s-1}, \dots, \varepsilon_1$  at points  $p_1, \dots, p_s, p'_{s-1}, \dots, p'_1$  on the boundary in that cyclic order. Attach  $s - 1$  triangles to  $D''$ , as in Fig. 4, in the following way: Each triangle  $T_i$  has angles  $\varepsilon_i, \varepsilon_{i+1}$ , and  $\pi - e_{i+1}$  at vertices  $A_i, B_i, C_i$  for  $0 < i < s - 1$ ; the last triangle  $T_{s-1}$  has angles  $\varepsilon_{s-1}, 2\varepsilon_s - \pi$  and  $\pi - e_s$ . This is possible by the definition of  $\varepsilon_i$ . For  $i$  odd identify the edge  $A_i B_i$  with  $p_i p_{i+1}$  by adjusting the scale of  $T_i$  suitably; for  $i$  even identify  $A_i B_i$  with  $p'_i p'_{i+1}$ . The resulting disc  $D'''$  has exterior angles  $e_1, \dots, e_s$  in some order. Note that whenever some  $\varepsilon_j = 0, j < s$  or when  $\varepsilon_s = \frac{1}{2}\pi$ , the corresponding triangles are degenerate. This offers no difficulty in the argument; in effect, no triangle is added at that stage, but the argument is still valid.



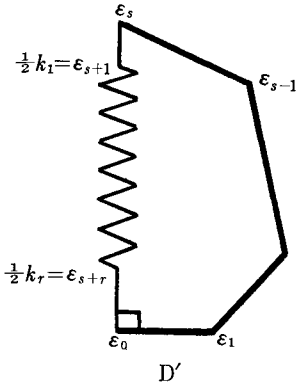

Fig. 3a

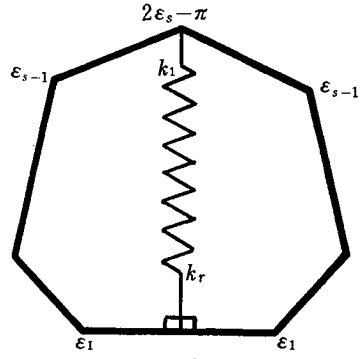

Fig. 3b

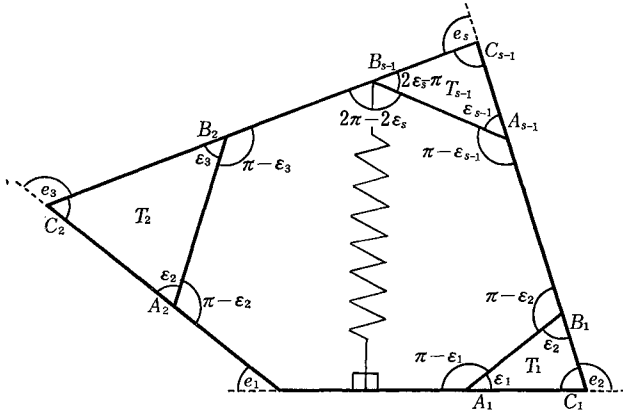

Fig. 4

To complete the construction, we observe that any two adjacent exterior angles may be permuted by the method displayed in Fig. 5; repeated application of this construction produces a disc  $D$  from  $D''$  which now has the correct

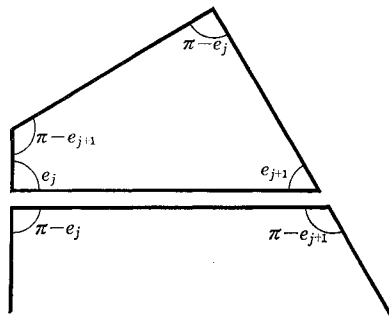

Fig. 5

curvatures and exterior angles, and these latter in the correct cyclic order around the boundary. This completes Case II.

We now consider the general case. Let  $k_1, \dots, k_t, \dots, k_r$  be the desired curvatures, and  $e_1, \dots, e_s$  the exterior angles. Assume that  $k_i > 0$  iff  $i \leq t$ . The proof proceeds by induction on  $t$ .

Let  $t = 0$ . This case is proved by induction on  $s$ .

Since  $\sum_{i=1}^r k_i \leq 0$ ,  $\sum_{j=1}^s e_j \geq 2\pi$ , so  $s \geq 3$ , and if  $s = 3$  then all  $e_j$  are positive, which is done by Case II. Assume the result for  $s - 1$ . If all  $e_j > 0$ , Case II applies. Otherwise there is some  $e_j < 0$  such that  $e_{j+1} > 0$ . Now the construction from Case I (Fig. 2) which was used for  $r = 0$  applies verbatim.

Suppose now that the result is known for  $t - 1$ . (The following argument was discovered by David Stone, to whom we are grateful.) Suppose a disc is to be constructed with curvatures  $k_1, \dots, k_t, \dots, k_r$  and exterior angles  $e_1, \dots, e_s$ . By induction there is a disc  $D'$  with interior curvatures  $k_2, \dots, k_t, \dots, k_r$  and exterior angles  $e_1, \dots, e_s, \frac{1}{2}k_1, \frac{1}{2}k_1$ , in that order. By Case I there exists a disc  $D''$  with curvature  $k_1$  and exterior angles  $\pi - \frac{1}{2}k_1, \pi - \frac{1}{2}k_1$ . Adjusting the scale of  $D''$  and amalgamating them as illustrated in Fig. 6 yields the desired disc  $D = D' \cup D''$ .

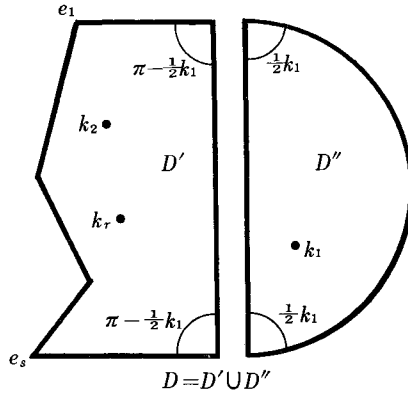

Fig. 6

This completes the proof of the converse to the Gauss-Bonnet theorem for the disc.

### 7. The 2-sphere with holes

The argument here proceeds by induction on  $H$ , the number of holes.

If  $H = 0$ , then  $M$  is the sphere. In this case we are given real numbers  $k_1, \dots, k_r$ , each less than  $2\pi$ , with  $\sum_1^r k_i = 4\pi$ . Construct a PL Riemannian disc  $D$  having exterior angles  $\frac{1}{2}k_1, \dots, \frac{1}{2}k_r$  around the boundary and being flat elsewhere. The existence of  $D$  was proved in the preceding section. Then

the double of  $D$  along its boundary is the desired 2-sphere.

The case where  $H = 1$ , that is, where  $M$  is the disc, was dealt with in the preceding section. Henceforth we assume  $H \geq 2$  and proceed by induction on  $H$ . Using the inductive assumption, we will construct a PL Riemannian manifold  $M'$  which is a sphere with  $H - 1$  holes.  $M$  will then be constructed from  $M'$  by identifying two edges on one of the boundary components of  $M'$ .

Let  $e_1, \dots, e_t$  be the desired exterior angles on the first boundary component of  $M$ , and  $e_{t+1}, \dots, e_{t+n}$  those on the second component. Let  $e_j, t + n + 1 \leq j \leq s$  be the remaining angles, and  $k_1, \dots, k_r$  the desired curvatures. There are two cases.

*Case I:* Among the boundary curves of  $M$  there are at least two on which a strictly negative exterior angle is to appear. Assume without loss of generality that  $e_1 < 0$ , and  $e_{t+1} < 0$ . Construct  $M'$  (with  $H - 1$  holes) having the following data: curvatures  $k_1, \dots, k_r$ ; exterior angles  $e_1 + \pi, e_2, \dots, e_t, e_{t+1} + \pi, e_{t+2}, \dots, e_{t+n}$  at points  $q_1, \dots, q_{t+n}$  on one boundary component; and exterior angles  $e_j, j > t + n$  distributed appropriately on the remaining boundary components. It is clear that these data are admissible for a sphere with  $H - 1$  holes (note that  $e_1 + \pi < \pi$  and  $e_{t+1} + \pi < \pi$ ). Choose a point  $x$  on the boundary arc from  $q_1$  to  $q_{t+n}$  and a point  $y$  between  $q_t$  and  $q_{t+1}$ , such that the subarcs from  $q_1$  to  $x$  and  $y$  to  $q_{t+1}$  have the same length (Fig. 7a). Identify these subarcs as in Fig. 7b to obtain  $M$ .

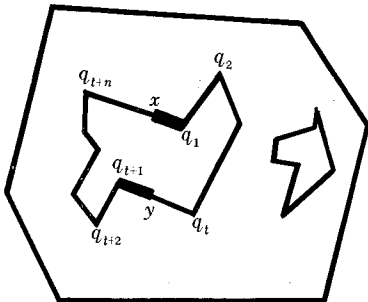

Fig. 7a

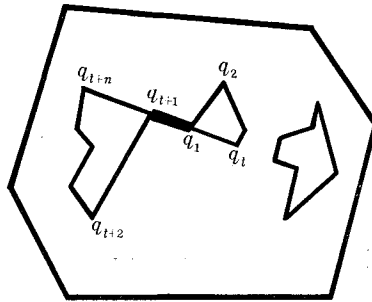

Fig. 7b

*Case II:* All exterior angles on one boundary component are positive; without loss of generality assume  $e_j > 0$  for  $1 \leq j \leq t$ . If Case I does not apply, this must occur. It is possible that  $t = 0$ . Proceed as in Case I except that one boundary component has exterior angles  $\frac{1}{2}\pi, \frac{1}{2}\pi, e_1, \dots, e_t, \frac{1}{2}\pi, \frac{1}{2}\pi, e_{t+1}, \dots, e_{t+n}$  at vertices  $A, B, q_1, \dots, q_t, C, D, q_{t+1}, \dots, q_{t+n}$ . If arc  $AB$  has the same length as arc  $CB$ , identify them as in Fig. 8 to produce the desired manifold  $M$ . Otherwise, assume without loss of generality that arc  $CD$  is shorter than arc  $AB$ . Our objective is to modify  $M'$  in such a way that the lengths of

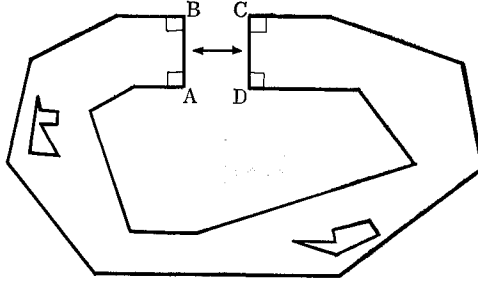

Fig. 8

these two sides are equalized. This construction is illustrated in Fig. 9, which is idealized in the usual way.

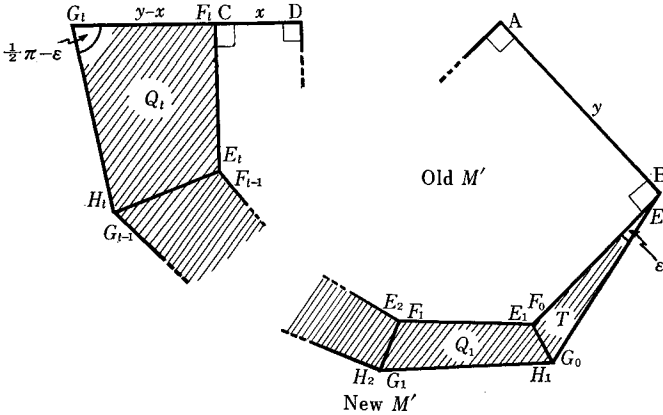

Fig. 9

Let  $x = \text{length of } CD < \text{length of } AB = y$ . For any small  $\varepsilon > 0$ , construct a triangle  $T$  and quadrilaterals  $Q_i, 1 \leq i \leq t$ , as follows:  $T$  has angles  $\varepsilon, \frac{1}{2}(\pi + e_1)$  and  $\frac{1}{2}(\pi - e_1) - \varepsilon$  at vertices  $E_0, F_0$  and  $G_0$ , and the length of  $E_0F_0$  equals that of  $Bq_1$ . For  $i < t, Q_i$  has angles  $\frac{1}{2}(\pi + e_i), \frac{1}{2}(\pi + e_{i+1}), \frac{1}{2}(\pi - e_{i+1}) - \varepsilon$ , and  $\frac{1}{2}(\pi - e_i) + \varepsilon$  cyclically at vertices  $E_i, F_i, G_i$  and  $H_i$ . The last quadrilateral  $Q_t$  has angles  $\frac{1}{2}(\pi + e_t), \frac{1}{2}\pi, \frac{1}{2}\pi - \varepsilon$ , and  $\frac{1}{2}(\pi - e_t) + \varepsilon$  at  $E_t, F_t, G_t, H_t$ . The lengths of the sides are adjusted so that  $E_iF_i$  matches  $q_iq_{i+1}$  and  $F_iG_i$  matches  $E_{i+1}H_{i+1}$ . Consecutively adding the discs  $T, Q_1, \dots, Q_t$  as in Fig. 9 is now possible. This process reproduces the exterior angles  $e_1, \dots, e_t$  in new locations, absorbs their old locations as flat interior points, and increases the length of side  $CD$ . As long as

$$\varepsilon < \frac{1}{2}(\pi - \max \{e_1, \dots, e_t\})$$

the construction can be carried out. As  $\varepsilon$  approaches this limiting value, the

side  $CD$  lengthens indefinitely. Hence for some specific  $\varepsilon$ , it will be lengthened to precisely  $y$ .

Now we may identify side  $AB$  and the new side  $CD$  to produce the required sphere with  $H$  holes just as in Fig. 8. Note that the end points of these two sides become flat boundary points. Note also that the case  $t = 0$  is handled by this argument.

Since for any proposed data either Case I or Case II must apply, this completes the inductive proof, and the converse to the Gauss-Bonnet theorem is now established for spheres with holes.

### 8. Compact orientable two-manifolds

Let  $M$  be a compact orientable two-manifold with  $H \geq 0$  boundary components. The *genus*  $G$  of  $M$  is defined to be the genus of the closed manifold  $M'$  constructed by adding a disc to fill in each boundary component. Since  $\chi(M') = 2 - 2G$  and also  $\chi(M') = \chi(M) + H$ , we have  $\chi(M) = 2 - 2G - H$ . The case  $G = 0$  is just that of a sphere with  $H$  holes, which we have considered in § 7. Thus we may assume  $G > 0$  in the present section.

Suppose first that  $H = 0$ , that is,  $M$  is a closed orientable manifold. The theorem in this case (as well as in the nonorientable case) was proved by Krigelman in [15]. The argument to follow is different.

Suppose that we must produce a closed orientable two-manifold of genus  $G$  with preassigned curvatures  $k_1, \dots, k_r$ . Thus  $\sum k_i = 2\pi(2 - 2G)$ . Construct a sphere  $S$  with  $G + 1$  holes and exterior angles  $\frac{1}{2}k_1, \dots, \frac{1}{2}k_r$  around one boundary component and being flat elsewhere. This is possible since  $2\pi\chi(S) = 2\pi(2 - (G + 1)) = 2\pi(1 - G) = \sum \frac{1}{2}k_i$ . Then  $M = 2S$ , the double of  $S$ , is the desired manifold.

Now we may assume  $H > 0$  and  $G > 0$ . Let the preassigned data be curvatures  $k_1, \dots, k_r$  and exterior angles  $e_1, \dots, e_t; \dots; \dots; e_s$ . (Semicolons here indicate the distribution of exterior angles amongst the several boundary components.) Then the following data are admissible for a manifold of genus  $G - 1$  with  $H$  holes: curvatures  $k_1, \dots, k_r$  and exterior angles

$$\frac{1}{2}\pi, \dots, \frac{1}{2}\pi \text{ (eight angles), } e_1, \dots, e_t; \dots; \dots, e_s .$$

Indeed,

$$\sum k_i + \sum e_j + 4\pi = 2\pi(2 - 2G - H) + 4\pi = 2\pi(2 - 2(G - 1) - H) .$$

By induction on  $G$  (the case  $G = 0$  having been handled previously) we may assume the existence of a manifold  $M'$  realizing these data, schematically displayed in Fig. 10.

Suppose the lengths  $a = a', c = c'$  and  $b = d$ . Then we may identify  $a$  with  $a'$  and  $c$  with  $c'$  to produce an orientable manifold of genus  $G - 1$  with  $H + 2$

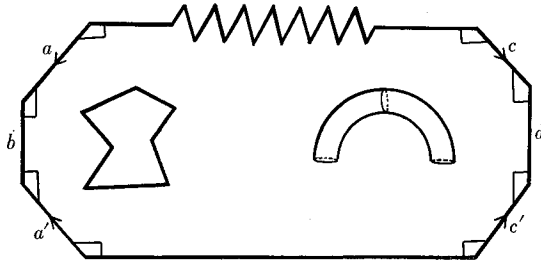

Fig. 10

boundary components. The two flat boundary components  $b$  and  $d$ , being equal in length, may be identified to produce a manifold of genus  $G$  with  $H$  boundary components, having the originally prescribed curvatures and exterior angles. The construction which follows modifies the lengths  $a, \dots, d$  so as to produce the desired equalities, after which the above identifications are made to finish the argument.

If we ignore for the moment the desired equality of  $b$  and  $d$  we can apply the construction introduced in [15] to equalize  $a$  with  $a'$  and  $c$  with  $c'$ . For instance, if  $a' < a$  we may attach along the edge  $b$  a right triangle with legs of

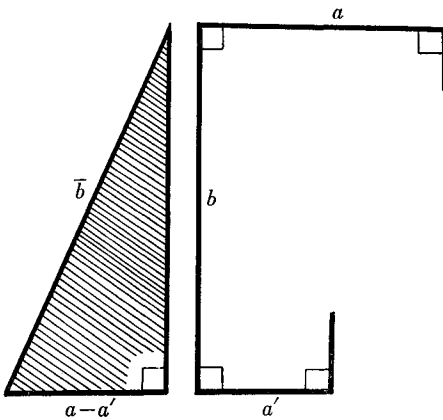

Fig. 11

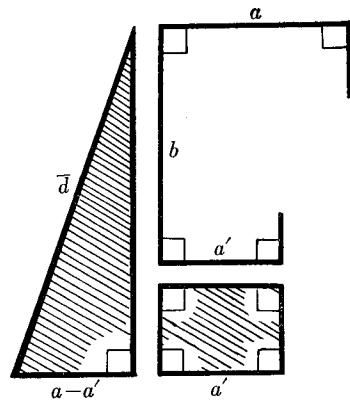

Fig. 12

length  $b$  and  $a - a'$  (Fig. 11), and similarly for  $c$  and  $c'$ . After this construction, if the new lengths  $\bar{b}$  and  $\bar{d}$  are equal we may perform the appropriate identifications as described above. If they are unequal, say  $\bar{b} < \bar{d}$ , we modify the previous construction as follows (Fig. 12): First add along edge  $a'$  ( $< a$ ) a rectangle whose dimensions are  $a'$  and  $\sqrt{\bar{d}^2 - \bar{b}^2} + b^2 - b$ . Then add a right triangle with sides  $a - a'$  and  $\sqrt{\bar{d}^2 - \bar{b}^2} + b^2$  and hypotenuse  $\bar{d}$ . (Recall that  $\bar{b}^2 - b^2 = (a - a')^2$ .)

Finally we identify the two sides of length  $a$  with each other, the two sides of length  $c$  with each other, and then the two resulting boundary curves of length  $\bar{d}$  with each other, producing the desired manifold.

### 9. Compact nonorientable two-manifolds

Let  $M$  be a compact nonorientable two-manifold with  $H \geq 0$  boundary components. Filling each of these in with a disc, we obtain a closed nonorientable manifold  $M'$  of genus  $G \geq 1$ . We call  $G$  the *genus* of  $M$  as well. Since  $\chi(M') = 2 - G$  and  $\chi(M') = \chi(M) + H$ , we have

$$\chi(M) = 2 - G - H .$$

Here  $M$  is a sphere with  $G$  cross-caps attached (i.e., the connected sum of  $G$  projective planes) and with  $H$  holes.

Suppose we must produce such a manifold with preassigned curvatures  $k_1, \dots, k_r$  and exterior angles  $e_1, \dots; \dots; \dots, e_s$ . Since a sphere with  $H + G$  holes has the same Euler characteristic, there exists by § 7 such a manifold with curvatures  $k_1, \dots, k_r$ , exterior angles  $e_1, \dots, e_s$  on the first  $H$  boundary components, and  $G$  flat boundary components. Since a flat Möbius band obviously exists with any boundary length, we may cap off the  $G$  flat boundary components with appropriate Möbius bands (cross-caps) and produce a nonorientable manifold of genus  $G$  with  $H$  boundary holes, having the required curvatures and exterior angles.

This completes the proof of the converse to the Gauss-Bonnet theorem.

### References

- [ 1 ] A. D. Alexandrov, *Konvexe Polyeder*, Akad. Verlag, Berlin, 1958.
- [ 2 ] T. Banchoff, *Critical points and curvature for embedded polyhedral surfaces*, Amer. Math. Monthly **77** (1970) 475-485.
- [ 3 ] ———, *Critical points and curvature for embedded polyhedra*, J. Differential Geometry **1** (1967) 245-256.
- [ 4 ] M. Berger, *On Riemannian structures of prescribed Gauss curvature for compact two-dimensional manifolds*, J. Differential Geometry **5** (1971) 325-332.
- [ 5 ] O. Bonnet, *Mémoire sur la théorie générale des surfaces*, J. École Polytech. **19** (1848) 1-146.
- [ 6 ] S. S. Chern, *Curves and surfaces in Euclidean space*, Studies in Global Geometry and Analysis, Vol. 4, Math. Assoc. Amer., 1967, 16-56.
- [ 7 ] C. F. Gauss, *Disquisitiones generales circa superficies curvas*, Comm. Soc. Göttingen **6** (1828) 99-46 = Werke, 4, 217-258.
- [ 8 ] H. Gluck, *Deformations of normal vector fields and the generalized Minkowski problem*, Bull. Amer. Math. Soc. **77** (1971) 1106-1110.
- [ 9 ] ———, *The generalized Minkowski problem in differential geometry in the large*, Ann. of Math. **96** (1972) 245-276.
- [10] J. Kazdan & F. W. Warner, *Integrability conditions for  $\Delta u = k - Ke^{au}$  with applications to Riemannian geometry* Bull. Amer. Math. Soc. **77** (1971) 819-823.
- [11] ———, *Curvature functions for 2-manifolds with negative Euler characteristic*, Bull. Amer. Math. Soc. **78** (1972) 570-574.

- [12] —, *Curvature functions for compact manifolds*, Ann. of Math. **99** (1974) 14–47.
- [13] —, *Curvature functions for open manifolds*, Ann. of Math. **99** (1974) 203–219.
- [14] —, *Existence and conformal deformation of metrics with prescribed Gaussian and scalar curvatures*, Ann. of Math., to appear.
- [15] K. Krigelman, *The converse to the Gauss-Bonnet theorem for closed two-manifolds*, Ph. D. thesis, University of Pennsylvania, 1972.
- [16] N. Kuiper, *Der Satz von Gauss-Bonnet für Abbildungen in  $E^N$  und damit verwandte Probleme*, Jber. Deutsch. Math.-Verein. **69** (1967) 77–88.
- [17] H. Minkowski, *Allgemeine Lehrsätze über konvexer Polyeder*, Nachr. Ges. Wiss. Göttingen (1897), 198–219.
- [18] —, *Volumen und Oberfläche*, Math. Ann. **57** (1903) 447–495.
- [19] J. Moser, *On a nonlinear problem in differential geometry*, Dynamical Systems (M. Peixoto, ed.), Academic Press, New York, 1973, 273–280.

UNIVERSITY OF PENNSYLVANIA  
BRYN MAWR COLLEGE  
CORNELL UNIVERSITY