

Large Hadron Collider Project

LHC Project Report 219

The Cryogenics of the LHC Interaction Region Final Focus Superconducting Magnets

R. Byrns³, Y. Huang², J. Kerby², Ph. Lebrun¹, L. Morrison³, T. Nicol², T. Peterson²,
R. Trant¹, R. van Weelderen¹, J. Zbasnik³

Abstract

The LHC interaction region final focus magnets will include four superconducting quadrupoles cooled with pressurized, static superfluid helium at 1.9 K. The heat absorbed in pressurized He II, which may be more than 10 Watts per meter due to dynamic heating from the particle beam halo, will be transported to saturated He II at 1.8 K and removed by the 16 mbar vapor. This paper discusses the conceptual design for the cryogenics of the interaction region final focus superconducting magnets and the integration of this magnet system into the overall LHC cryogenic system.

¹CERN, LHC Division

²Fermilab, USA

³Lawrence Berkeley National Laboratory, USA

Presented at ICEC 17, 14-17 July 1998, Bournemouth, UK

Administrative Secretariat
LHC Division
CERN
CH - 1211 Geneva 23
Switzerland

Geneva, 31 July 1998

The Cryogenics of the LHC Interaction Region Final Focus Superconducting Magnets

R. Byrns³, Y. Huang², J. Kerby², Ph. Lebrun¹, L. Morrison³, T. Nicol², T. Peterson², R. Trant¹, R. van Weelderren¹, J. Zbasnik³

¹CERN, ²Fermilab, ³Lawrence Berkeley National Laboratory

The LHC interaction region final focus magnets will include four superconducting quadrupoles cooled with pressurized, static superfluid helium at 1.9 K. The heat absorbed in pressurized He II, which may be more than 10 Watts per meter due to dynamic heating from the particle beam halo, will be transported to saturated He II at 1.8 K and removed by the 16 mbar vapor. This paper discusses the conceptual design for the cryogenics of the interaction region final focus superconducting magnets and the integration of this magnet system into the overall LHC cryogenic system.

1 INTRODUCTION AND SYSTEM DESCRIPTION

The Large Hadron Collider (LHC) at CERN will include eight interaction region final focus magnet systems, one on each side of the four beam collision points. Figure 1 is a diagram of an LHC interaction region final focus magnet assembly or “inner triplet” [1]. Each inner triplet will consist of four quadrupole cold mass assemblies each approximately 6-meters long, various multipole correctors, two beam position monitors (BPM), and supplementary heat absorbers (TAS), connected through a cryogenic feedbox (not shown) to the cryogenic distribution line. The quadrupoles and associated components will be assembled into three cryostats. The overall length of each triplet will be approximately 30 m, not including the feedbox, and the total cold mass of each triplet will be about 22000 Kg.

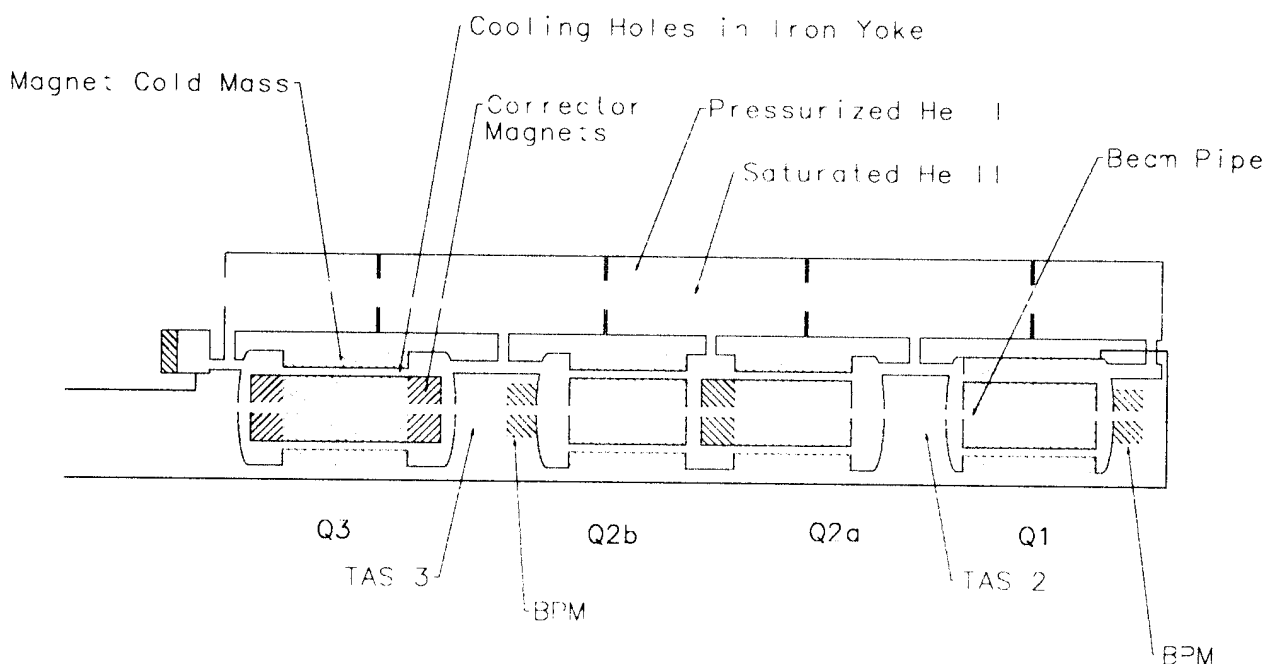

Figure 1 Diagram of LHC interaction region final focus magnets and cooling scheme

2 COOLING SCHEME

The inner triplet quadrupole magnets will be cooled in static baths of pressurized He II nominally at 1.9 K. A helium gas-cooled thermal shield at 50 to 75 K will intercept static thermal conduction and radiation heat loads. Table 1 lists the estimated heat loads at various temperatures. The dynamic heat load to 1.9 K due to the particle beam interactions totals about 162 W over the 30 meters and is unevenly distributed, with a maximum of over 10 W/m in Q1 [2], about an order of magnitude more than in the main arc magnets.

Table 1 Inner triplet heat loads

Temperature levels	50 to 75 K	4.6 K	1.9 K	Current lead flow (g/s)
Static heat loads (W)	250	22	10	
Dynamic heat loads (W)	0	21	162	
Total heat loads (W)	250	43	172	3.7

This 1.9 K heat load will be transported radially from around the beam pipe and coil via pressurized He II through spaces in the magnet collars and yoke. Then the heat will flow axially through holes in the iron yoke and again radially outward through a tee at the interconnect to the He II heat exchanger. The heat exchanger, made from a corrugated copper tube inside a stainless steel pipe, follows the same cooling concept as that for the LHC arc magnets [3,4]. Two-phase 1.8 K helium flows inside of the corrugated copper tube immersed in the pressurized He II. The large heat load forces a large copper tube surface area for heat transfer in order to keep temperature differences small and the magnet at around 1.90 K. A large cross-section within the corrugated copper tube is also required to keep the vapor flow velocity well below 5 m/s, in order to ensure fully separated flow [5]. Due to the resulting large size, the heat exchanger will be placed above the cold mass in the cryostats as shown in Figure 1 rather than within the cold mass.

Cryogenics will be provided by the same system that cools the rest of the 1.9 K magnets in LHC [6,7,8]. Figure 2 shows a simplified flow schematic for the inner triplet cryogenic system at the left

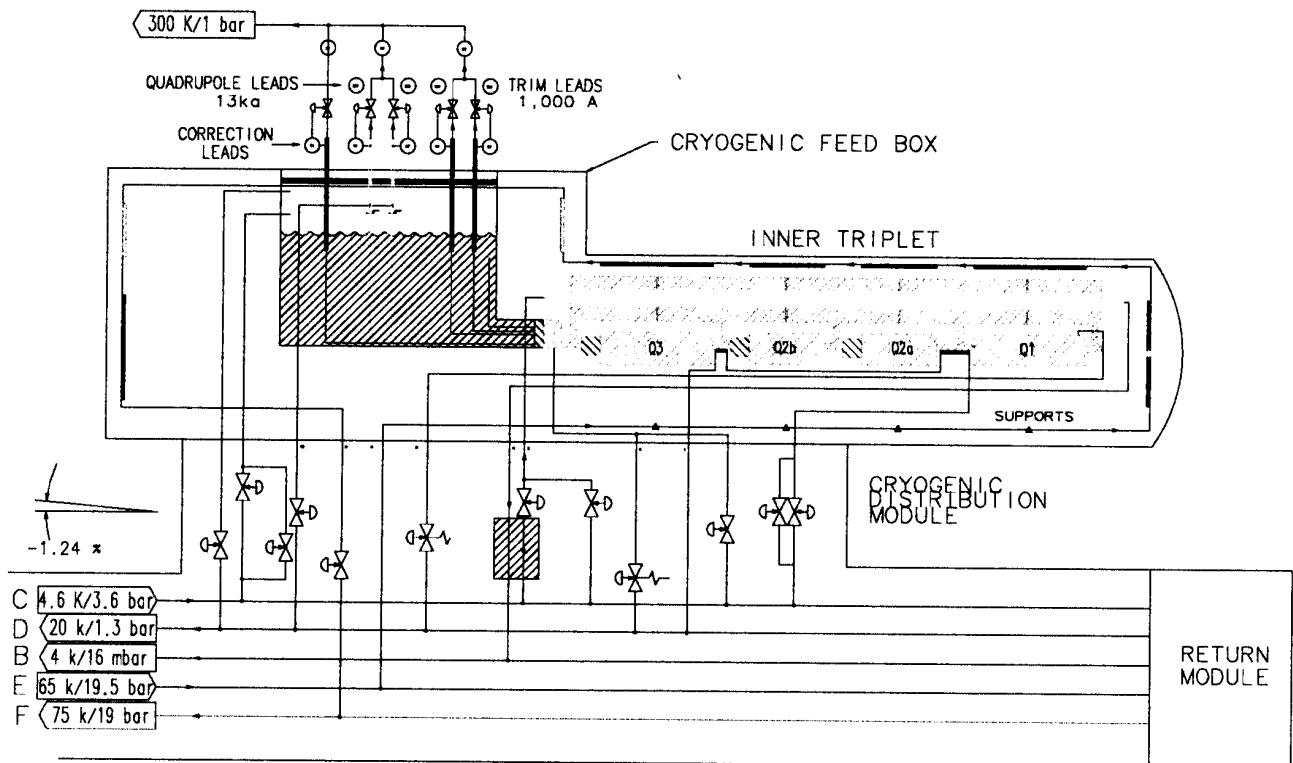

Figure 2 Simplified flow schematic for the inner triplet cryogenic system

side of Point 5 and its connections to the cryogenic distribution line. The saturated 1.8 K vapor, boiling out of the corrugated-tube heat exchanger, passes through a counterflow heat exchanger which precools the 4.6 K, 3.6 bar supply from header C to around 2.2 K for the He II cooling loop. The nominally 16 mbar, 3.5 K helium gas travels 3.3 km through header B to the cold compressors at the helium refrigerator.

Table 2 shows the predicted temperatures and pressures through the entire system from the cold compressor to the Q1 quad in the worst case location (left side of Point 5). The left side of Point 5 is the “worst case” (highest temperature) due to the large elevation change relative to the cold compressor, full 3.3 km octant distance from the cold compressors, and the high particle beam luminosity. The predicted maximum superfluid temperature is 1.930 K. Since the He II heat exchanger is larger than those that have been previously tested, a thermal test of a full-scale prototype is planned in 1999 in order to verify the thermal performance of this design.

Table 2 Temperatures and pressures from magnets through transfer line to cold compressor

System temperature or pressure location	Pressure (mbar)	Temperature (K)
Pressure at cold compressor (flow through header B is nominally at 3.5 K; saturation temperature corresponding to pressure is shown in parentheses)	15.0	(1.776)
Pressure at tunnel feedbox after adding the pressure drop due to flow through header B in the 3.3 km of transfer line	18.6	(1.836)
Pressure at tunnel feedbox after adding the pressure drop due to elevation change through header B in the 3.3 km of transfer line	19.2	(1.845)
Pressure and temperature in saturated He II at the feedbox end of the triplet after adding the pressure drop through the JT heat exchanger	19.6	1.851
Pressure and temperature in saturated He II at the Q1 end of the triplet after adding the pressure drop through the corrugated pipe along the inner triplet	19.8	1.855
Temperature in the pressurized He II after adding the temperature drop across the heat exchanger wall to the saturated He II		1.889
Temperature in the pressurized He II after adding the temperature drop through the pressurized He II from the magnet center to the He II heat exchanger		1.900
Temperature in pressurized He II at warmest point in Q1, including regulation margin		1.930

3 FEEDBOX CONCEPT

The interface between the cryogenic distribution system and the inner triplet magnet assembly is the cryogenic feedbox. A concept of the feedbox in the most complicated location, where a cryogenic connection to separation dipoles is required, is shown in Figure 3.

The general feedbox design constraints are to: provide cryogenic, power, beam tube, and instrumentation connections to the inner triplets, corrector magnets, and those separation dipoles which are located near the inner triplets; operate certain separation dipoles in a bath of boiling 4.6 K liquid helium; provide for the operation of the inner triplets at 1.90 K in pressurized He II, including separation of the normal and superfluid volumes with “lambda plates”; and allow removal or repair of current leads with the feedbox connected in the beamline.

A major component of the feedbox will be current leads for the quadrupole and corrector magnets. Quadrupole electric currents will be as high as 13 kA. It is planned to use high temperature superconductor (HTS) for the high-current leads, as in the rest of the LHC. The current leads will be mounted on the top of the feedbox, extending into a 4.6 K liquid helium vessel, where current is carried by low temperature superconductor in the liquid helium through a “lambda plate” to the pressurized He II space. 20 K gas for cooling the upper end of the HTS leads is provided by a manifold connected to header D of the cryogenic distribution line, with individual feed lines and electrical isolation to each HTS lead.

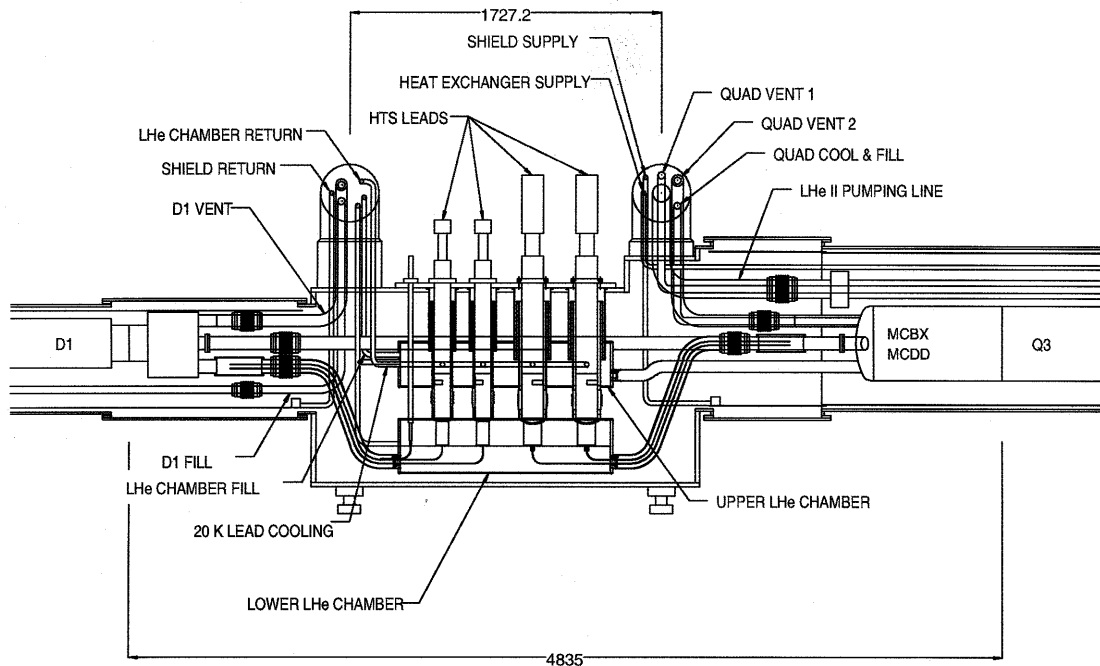

Figure 3 Elevation view of feedbox for left side of IR2 and IR8 (dimensions in mm)

4 CONCLUSIONS

The CERN scheme for providing pressurized superfluid in a magnet string by means of a long He II heat exchanger will be scaled-up for the removal of an average of 5 W/m of heat at 1.9 K over 30 meters in the LHC interaction region final focus magnets. A thermal test of a full-scale prototype He II heat exchanger is planned in 1999 in order to verify the thermal performance of this design. The cooling of these final focus magnets will be provided by the LHC cryogenic system, with special feedboxes containing HTS current leads and tying the inner triplet magnets to the cryogenic distribution line.

5 REFERENCES

1. Ostojic, R., T.M. Taylor and S. Weisz, Systems Layout of the Low- β Insertions for the LHC Experiments, Presented at PAC 1997, May 1997, Vancouver, Canada.
2. Mokhov, N., private communication
3. Cyvoct, A., Ph. Lebrun, M. Marquet, L.Tavian and R. van Weelderens, Heated Two-Phase Flow of Saturated Helium II over a Length of 24 m, CERN-AT/91-28 (CR), LHC Note 169, (1991)
4. Casas, J., A. Cyvoct, Ph. Lebrun, M. Marquet, L.Tavian and R. van Weelderens, Design concept and first experimental validation of the superfluid helium system for the Large Hadron Collider (LHC) Project at CERN, *Cryogenics* 32, ICEC Supplement, (1992), p. 118.
5. Lebrun, Ph., L. Serio, L. Tavian, R. van Weelderens, Cooling Strings of Superconducting Devices Below 2 K: The Helium II Bayonet Heat Exchanger, In: *Advances in Cryogenic Engineering*, Vol. 43, (1998)
6. The LHC Study Group, *The Large Hadron Collider*, CERN/AC/95-05 (LHC), 20 October, (1995)
7. Lebrun, Ph. Superfluid Helium Cryogenics for the Large Hadron Collider Project at CERN *Cryogenics* 34, ICEC Supplement (1994)
8. Chorowski, M., B. Hilbert, Ph. Lebrun, L. Serio, L. Savian, U. Wagner, and R. van Weelderens, A Proposal for Simplification of the LHC Cryogenic Scheme, CERN-ACR Division/1997-09-15, LHC Project Note 106, (1997)