

The Determination of *P*-wave Attenuation Values in the Earth's Mantle

I. S. Berzon, I. P. Passechnik and A. M. Polikarpov

(Received 1974 May 14)*

Summary

Direct determinations of the *P*-wave attenuation parameter, Q_p , in the Earth's mantle are made using changes in the form of *P*-wave amplitude spectra as a function of distance. Two independent sets of experimental data from axisymmetrical surface sources are used: (1) 288 records of narrow-band SVKM seismometers from 19 events, and (2) 75 records of wide-band SVK seismometers from seven larger events.

The average Q_p value in the depth interval between 100 and 760 km is found to be 710 and in the interval 760–2900 km to be between 1200 and 1330. The estimate of the accuracy of these results is given and the comparison with other authors' results of direct and indirect Q_p determination is made.

Introduction

Among the numerous papers investigating the attenuation of seismic waves in the Earth's mantle (Anderson & Kovach 1964; Kovach & Anderson 1964; Press 1954) there are only a few papers devoted to direct determination of the value of longitudinal wave attenuation (Kanamori 1967b; Mikumo & Kurita 1968). In the majority of the papers (including the fundamental works by Anderson & Kovach 1964; Anderson, Ben-Menahem & Archambeau 1965; Kanamori 1967a) the results of the determination of the values of transverse wave attenuation are presented. The values of longitudinal wave attenuation were estimated by assuming that the quality factors (Q) of longitudinal and transverse waves, Q_p and Q_s , are directly proportional to one another and that their ratio is independent of depth, i.e. $Q_p/Q_s = \eta = \text{constant}$. The constant η is assigned different values by different authors; for example Anderson *et al.* 1964 give $\eta = 2.0$ – 2.5 and Kanamori (1967a) gives $\eta = 1.0$.

Some direct determinations of the values of longitudinal wave attenuation in the mantle (Kanamori 1967b; Frasier & Filson 1972) are based in a few records of earthquakes and explosions; however, Mikumo & Kurita (1968) used a large number of event recordings. The significant differences in the values of longitudinal wave attenuation in the mantle, as determined by several authors, are likely to be the result of the varying media properties or due to the lack of suitable data and a means of estimating the accuracy of the parameters being determined.

In the present paper determinations of longitudinal wave attenuation in the Earth's mantle are presented. They are based on a comparatively large number of experimental data from a wide range of epicentral distances, $\Delta = 1100$ – $11\ 800$ km.

* Received in original form 1974 January 23.

The methods used to determine the longitudinal wave attenuation parameters

The longitudinal wave attenuation in the Earth's mantle was determined from the change in form of the amplitude spectra with the increase of epicentral distances. This method was used with two modifications.

The first modification was described in detail by Berzon *et al.* (1962) and Passechnik (1970). Its essence is as follows: the logarithms of the ratio of *P* wave spectral amplitudes at frequencies f_i , with respect to a fixed frequency f_k , are plotted versus the seismic ray length L . L is estimated for different epicentral distances, Δ , and a fixed velocity–depth distribution. Examples of these plots are shown in Fig. 1. From the slope of the straight lines approximating these points the differences of the attenuation coefficients, $\Delta\alpha_p(f_i) = \alpha(f_i) - \alpha(f_k)$, are determined at different frequencies, f_i . Then, using the condition of no attenuation at zero frequency, the absolute values of the attenuation coefficients and their frequency dependence can be determined. In the case of linear dependence of the attenuation parameter, α_p , on frequency, i.e.

$$\alpha_p = kf, \tag{1}$$

then

$$Q_p = \pi / (k \bar{V}_p). \tag{2}$$

Here \bar{V}_p is the average velocity of longitudinal waves down to the maximum depth of penetration of the *P* wave ray.

In the second modification of this method the logarithm of the *P* wave spectral amplitude ratios are plotted against observed travel times, t_p , rather than ray length. In this case the knowledge of the velocity distribution with depth is not necessary. The slope of the line representing the data based on a certain frequency, f_i , characterizes the difference

$$\Delta\alpha_p(f_i)\bar{V}_p = [\alpha_p(f_i) - \alpha_p(f_k)]\bar{V}_p. \tag{3}$$

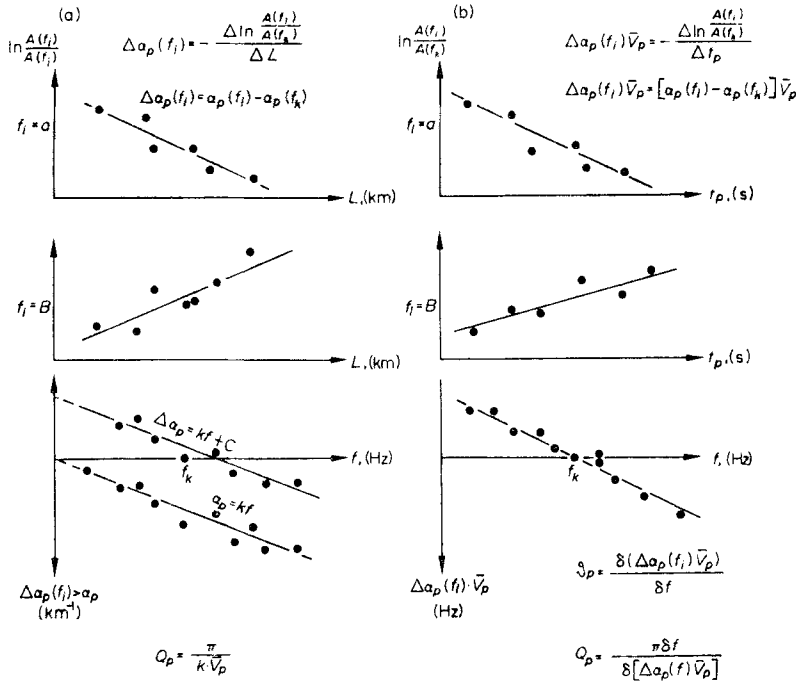

FIG. 1. Estimation of attenuation parameters using changes in *P* wave spectra with ray length, $L(a)$, or arrival time, $t_p(b)$.

\bar{V}_p is defined the same as before except in this method it is not necessary to be known or set beforehand. Using values of $\Delta\alpha_p(f_i)$ \bar{V}_p measured at different frequencies the dependence of $\Delta\alpha_p(f)$ \bar{V}_p upon frequency is determined. The slope of the line which approximates this dependence makes it possible to determine the attenuation decrement, \mathcal{S}_p , independent of frequency,

$$\mathcal{S}_p = \delta[\Delta_p(f) \bar{V}_p] / \delta f \tag{4}$$

or the quality factor,

$$Q_p = \pi \delta f / [\Delta_p(f) \bar{V}_p]. \tag{5}$$

The second modification of the method is given preference over the first because it uses only observed travel times and *P* wave amplitude spectra and because it does not require knowing the velocity dependence upon depth, $V_p(H)$, or the average velocity \bar{V}_p . It is necessary to determine \bar{V}_p only when estimating the function $\alpha_p(f)$ from the measured values of Q_p .

Initial experimental data

In order to exclude the effects of the source mechanism on the *P* wave amplitude spectra only records of waves excited by surface axisymmetrical sources were used. The records were obtained from the network of seismic stations within the USSR, situated both in the Asian and European parts of the country.

Two data sets were used to determine the attenuation parameters:

1. Records obtained from the seismometers of the SVKM type (Passechnik 1970) with peak displacement magnification at 1.0 cps. Some 288 recordings were used from 19 phenomena with magnitudes in the range 5.5–6.5 and at epicentral distances between 1100 and 11 800 km. The amplitude spectra were corrected for the frequency response characteristics of the seismometers. The α_p and Q_p determinations were carried out in the frequency range 0.2 to 1.67 cps (the period range 0.6–5 s).

2. Records obtained from the seismometers of the SVK type (Passechnik 1970) with broad, constant displacement response in the frequency range 0.1–5.0 cps. Some 75 recordings from phenomena in the magnitude range 6.5–7.3 and the distance range 3200–10 400 km were used.

This second set of data was used in an attempt to widen the frequency range of attenuation parameter determinations. This attempt was not successful, probably due to rather high frequency nature of the source spectra.

The processing of the first set of data was carried out using only the first variation of the method however both variations were applied to the second set of data.

The results of processing data obtained with filtering instrumentation (first data set)

In this section amplitude plots for different spectral components are presented and discussed. Fig. 2 is a plot of $\ln [A(f_i)/A(f_k)]$ values versus distance (*L*) for different frequencies, f_i , using the fixed frequency $f_k = 0.63$ cps. There is significant scattering of the points on this graph, probably due to a number of factors which are difficult to take into account. Some of these are the influence of horizontal inhomogeneities along the ray path, differences in the conditions beneath the recording station sites, and certain variations in the source spectra. Obviously, in this case without taking into account local variations in the medium, it is possible to determine only average laws of *P* wave attenuation. In spite of the scatter of the data a distinctive tendency toward stronger attenuation with distance of higher frequency components compared with those at low frequency is observed.

In order to obtain attenuation coefficient differences we averaged all of the data along the ray path (*L*) and along various intervals of the path (ΔL); the latter yielding

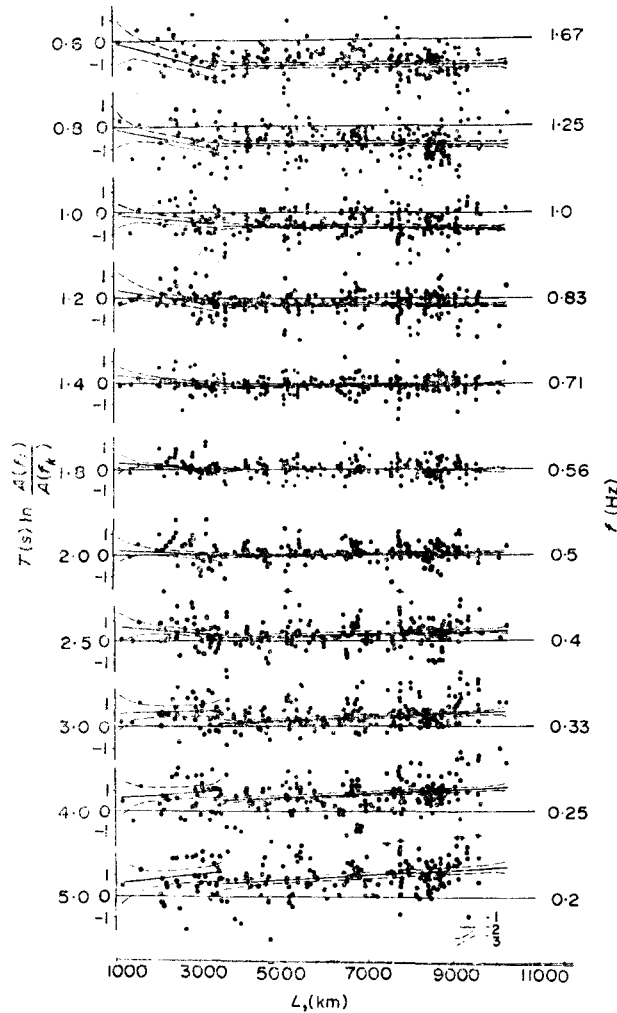

FIG. 2. The dependence of the logarithms of the ratio of the spectral components $A(f_i)$ for frequencies f_i to those at the frequency $f_k = 0.63$ cps, i.e. $\ln [A(f_i)/A(f_k)]$, as a function of P wave ray length L . These results are based on the first set of experimental data. The points represent the experimental data. The solid lines are regression lines, the slopes of which are averages values $\Delta\alpha_p(f_i)$ for intervals of P wave penetration depth from 100 to 760 km and from 760 to 2900 km. The dashed lines mark the 90 per cent confidence limits for the regression lines.

different values of $\Delta\alpha_p(f_i)$ for each interval. Minimum scatter was obtained when the data were divided into the following intervals, ΔL .

1. $\Delta L = 1140\text{--}3510$ km. This interval contains 43 points and corresponds to a depth of P wave penetration of 100–760 km.

2. $\Delta L = 3510\text{--}10\,244$ km. This interval corresponds to the depth interval 760–2900 km. The depth of 760 km is rather close to the upper boundary of what is generally taken to be the lower mantle. In Fig. 2 linear regression lines, $\ln [A(f_i)/A(f_k)]$, for both intervals are shown with 90 per cent confidence ranges.

The α_p frequency dependence

Using the obtained values $\Delta\alpha_p(f_i)$ for each of the depth intervals, we obtained the linear dependence of α_p with frequency within the 90 per cent confidence range (Figs 3 and 4). The equations of the regression lines are:

for $H = 100 - 760$ km

$$\alpha_p = 4.88 (\pm 1.31) f \cdot 10^{-4} \text{ km}^{-1} \tag{6}$$

for $H = 760 - 2900$ km

$$\alpha_p = 1.82 (\pm 0.63) f \cdot 10^{-4} \text{ km}^{-1}. \tag{7}$$

It is obvious from Figs 2-4 that the accuracy of the α_p determination for the lower mantle is greater than that for the upper mantle. This may be due to the smaller amount of experimental data for the upper mantle or the more pronounced horizontal inhomogeneities in this region when compared with the lower mantle. The averaged dependence of α_p on f for the entire depth interval (100-2900 km), from equations (6) and (7) is

$$\alpha_p = 2.54 (\pm 0.79) f \cdot 10^{-4} \text{ km}^{-1}. \tag{8}$$

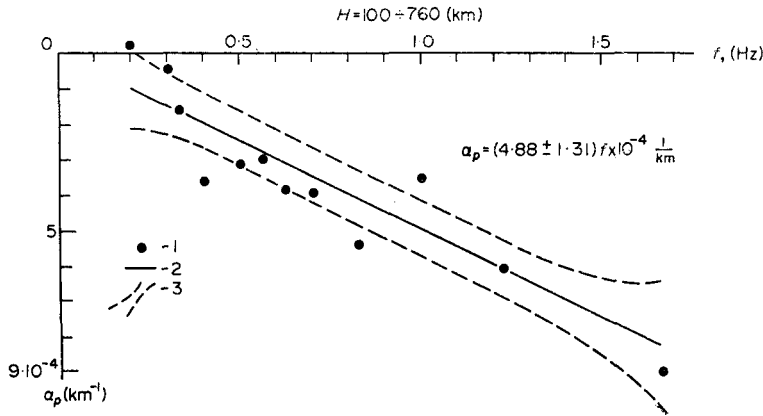

FIG. 3. The frequency (f) dependence of the absorption coefficient α_p of P waves in the upper mantle in the depth range 100-760 km. The points are the experimental data, the solid line the regression line, and the dashed lines the 90 per cent confidence ranges for this regression lines.

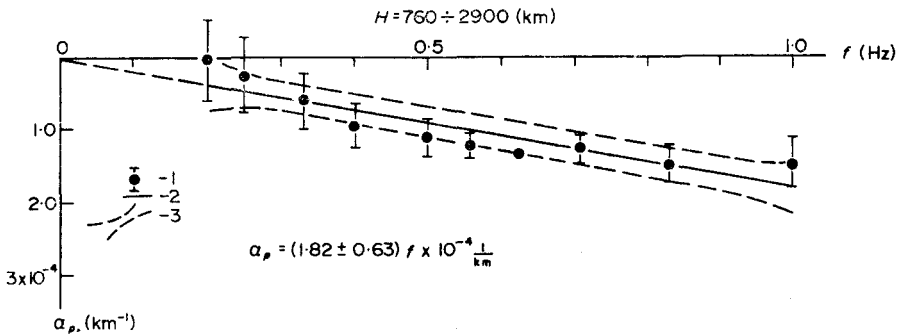

FIG. 4. The frequency (f) dependence of the absorption coefficient α_p for P waves in the lower mantle depth interval 760-2900 km. The definition of the symbols is the same as in Fig. 3.

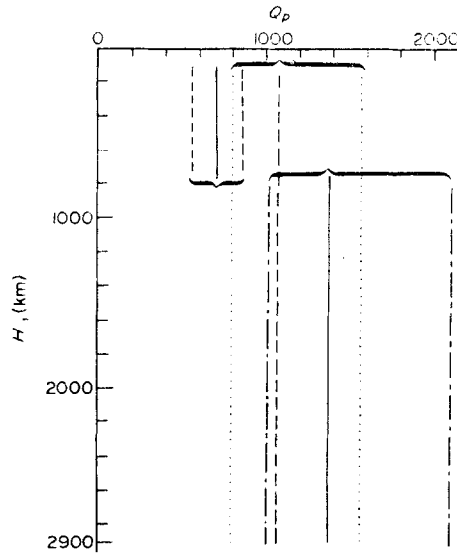

FIG. 5. The average Q_p values in the depth intervals 100–760 km and 760–2900 km, and the mean value in the depth interval 100–2900 km. The length of the brackets indicates the 90 per cent confidence ranges.

The mean values of Q_p

In the calculation of Q_p using equation (2) \bar{V}_p values were calculated from the variation of V_p with depth given by Ibrahim (1971). Combining these with equations (6)–(8) yielded Q_p values, and corresponding confidence ranges, for the different depth intervals. Fig. 5 shows that Q_p in the upper mantle is less than in the lower mantle and thus the seismic attenuation is greater within this region. The limiting Q_p values in the upper and lower mantle, based on the confidence ranges of α_p , do not overlap. As shown in Fig. 5, a mean Q_p value of 1080 over the entire depth interval (100–2700 km) was obtained using data from both the upper and lower mantle.

Results from the wide-band instrumentation (the second set of data)

Fig. 6 is a plot of $\ln [A(f_i)/A(F_k)]$ versus travel time t_p for various frequencies f_i and the fixed frequency $f_k = 0.63$ cps. The depth range which corresponds to the distance interval used nearly coincides with the depth interval associated with the lower mantle in the first set of data. Also in Fig. 6 are shown the straight regression lines based on the data and the 90 per cent confidence limits of these lines. The values of $\Delta\alpha_p(f) \bar{V}_p$ determined from the slopes of these lines are shown in Fig. 7 along with the corresponding confidence ranges. From the mean values of $\Delta\alpha_p(f) \bar{V}_p$ a regression line was determined the slope of which is

$$\vartheta_p = 2.63 (\pm 1.16) \cdot 10^{-3}, \quad (9)$$

consequently

$$Q_p = 1200 (+960, -370). \quad (10)$$

This value of Q_p is close to that determined from the first set of data for the same distance range.

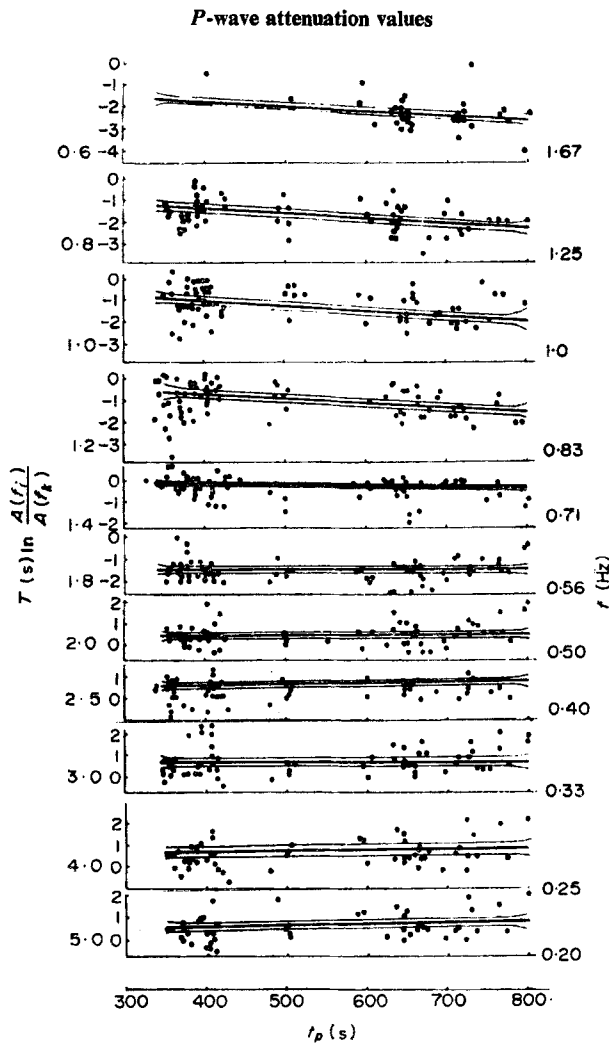

FIG. 6. The dependence of the logarithms of the ratio of the spectral components $A(f_1)$ for frequencies f_1 to those at the frequency $f_k = 0.63$ cps, i.e. $\ln [A(f_1)/A(f_k)]$, plotted versus P wave travel time t_p . These results are based on the second set of experimental data and the symbols are as defined in Fig. 2.

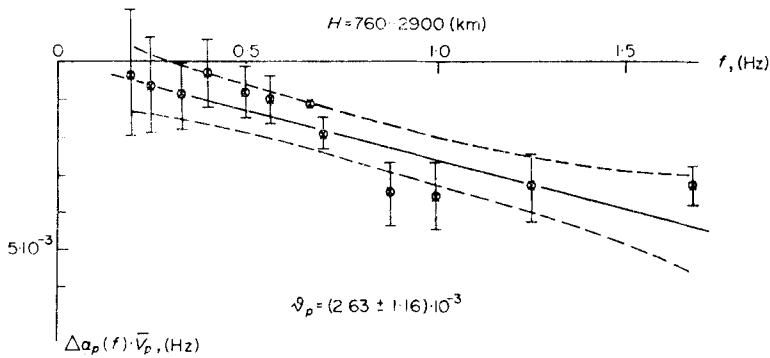

FIG. 7. The frequency dependence of the value $\Delta\alpha_p(f)\bar{V}_p$. Shown are the experimental data, the regression line, and the 90 per cent confidence limits. The slope of the regression line is Δ_p .

Comparison with published data

In Table 1 a comparison is made between the values of Q_p obtained here and those reported by authors who used other methods of Q_p determination. Included in the table are the results of Mikumo & Kurita (1968), Kanamori (1967b) and averaged Q_p values in different depth intervals calculated by us for the MM8 models of Anderson *et al.* (1965) and Kanamori (1967a). In order to calculate the attenuation in the entire upper mantle, including the Earth's crust, it is necessary to take into account the attenuation in the depth interval 0–100 km. In the light of Passechnik's (1970) experimental data we take the value of $Q_p = 220$ for this region, a similar value was calculated by us from Anderson's model.

From the table it can be seen that the upper mantle Q_p value derived from our data is greater than those from other authors' models. Our Q_p value is close to the value 480–800 obtained by Vinnik & Dashkov (1970) from the amplitude ratio of P and PP along a ray which penetrated to the somewhat greater depth of 1100 km.

The value of Q_p determined by us for the lower mantle are less than in Anderson's and Mikumo and Kurita's models and are close to the minimum values of Kanamori's model. Our value of lower mantle Q_p is close to the value 1400–2300 obtained by Frasier & Filson (1972) for a ray which was recorded at 72° distance with most of its path in the lower mantle.

The variation in Q_p between the upper and lower mantle from our study is less than determined by other authors. This discrepancy is likely to be due to the marked differences in the initial data used and in the method of processing. It is possible that the different frequency ranges of the various data used play a significant role. Mikumo & Kurita (1968) and Kanamori (1967b) used P waves in the frequency range 0.03–0.12 cps; a lower frequency interval than those considered by us. The same or lower frequencies were used by Press (1954) and Anderson *et al.* (1965) where Q_p values were inferred from Q determination based on transverse shear waves and on both Rayleigh and Love surface waves. Future studies made to increase the accuracy of the estimate of Q_p within the mantle should extend the frequency range to the widest possible limits. To this end it may be desirable to use data recorded near to the source.

Table 1

The comparison of the Q_p values in the upper and lower mantle

Depth interval (km)	Used velocities (km s ⁻¹)	Q_p according to:						
		Authors		Anderson <i>et al.</i> (1965)	Kanamori		Mikumo & Kurita (1968)	
		1st set	2nd set		1967a	1967b	M-5	M-14
100–760	9.04	710 ± 150		380	165			
760–2900	12.48	1330 ⁺⁷³⁰ ₋₃₆₀	1200 ⁺⁹⁶⁰ ₋₃₇₀	3210	1210	1690	4900	
100–2900	11.45	1080 ⁺⁴²⁰ ₋₂₈₅		990	420			
0–100	7.62	220		230	100			
0–760	8.91	530 ± 150		345	150	120	274	
0–2900	11.29	845 ⁺⁴²⁰ ₋₂₆₀		850	375	410–630	292	
0–900						180–240		
900–2900						1600–6000		

In conclusion, we would like to point out that the scatter of our data did not allow us to make a more detailed Q_p model of the mantle. However, in principle, the method used by us should make this goal possible upon the accumulation of more experimental data.

*The Institute of Physics of the Earth
Academy of Sciences of the USSR
Moscow, USSR*

References

- Anderson, D. L. & Kovach, R., 1964. Attenuation in the mantle and rigidity of the core from multiply reflected core phases, *Proc. Nat. Acad. Sci., U.S.*, **51**, 168–172.
- Anderson, D. L., Ben-Menahem, A. & Archambeau, C. B., 1965. Attenuation of seismic energy in the upper mantle, *J. geophys. Res.*, **70**, 1441–1448.
- Berzon, I. S., Epinatjeva, A. M., Parijskaya, G. N. & Starodubrovskaya, S. P., 1962. *Dinamicheskie harakteristiki seismicheskikh voln v realnih sredah*, Academizdat, Moskva.
- Frazier, C. W. & Filson, J., 1972. A direct measurement of Earth's short-period attenuation along a teleseismic ray path, *J. geophys. Res.*, **77**, 3782–3787.
- Ibrahim Abon-Bakr, K., 1971. Effects of a rigid core on the reflection and transmission coefficients from a multi-layered core–mantle boundary, *Pure appl. Geophys.*, **91**, 95–113.
- Kanamori, Hiroo, 1967a. Spectrum of P and PcP in relation to the mantle–core boundary and attenuation in the mantle, *J. geophys. Res.*, **72**, 559–571.
- Kanamori, Hiroo, 1967b. Attenuation of P waves in the upper and lower mantle, *Bull. earthq. Res. Inst.*, **45**, 299–312.
- Kovach, K. L. & Anderson, D. L., 1964. Attenuation of shear waves in the upper and lower mantle, *Bull. seism. Soc. Am.*, **54**, 1855–1864.
- Mikumo, T. & Kurita, T., 1968. Q -distribution for long-period P waves in mantle, *J. Phys. Earth*, **16**, 11–29.
- Passechnik, I. P., 1970. *Harakteristiki seismicheskikh voln pri jadernyh vzryvah i zemletrjasenijah*, *Izd. Nauka*, Moskva.
- Press, F., 1954. Rigidity of the Earth's core, *Science*, **124**, 1204.
- Vinnik, L. P. & Dashkov, G. G., 1970. Volni PP pri atomnyh vzryvah i zatuhanie prodolnih voln v verhney mantii, *Doklady AN USSR*, **190**, 1340–1343.