

THE EFFECTS OF CEMENTED CARBIDE BINDER COMPOSITION ON TOOL WEAR ENCOUNTERED IN SURFACING GREEN LUMBER¹

Abdel E. Bayoumi

Department of Mechanical and Materials Engineering
Washington State University
Pullman, WA 99164-2920

and

John S. Stewart and John A. Bailey

Department of Mechanical and Aerospace Engineering
North Carolina State University
Raleigh, NC 27695-7910

(Received September 1987)

ABSTRACT

This paper is a summary of work carried out over the past ten years on the wear of cemented carbides during cutting of green wood (Appalachian oak). Experimental evidence is presented showing that tool wear occurs through the preferential removal of the binder through chemical attack by extractives (tannic acid) in the wood followed by mechanical removal of tungsten carbide grains. This occurs when the remaining bond strength between the grains and the binder is no longer sufficient to withstand the action of the shear forces arising from relative motion between the cutting tool, work-piece, and chip. A theoretical model of the wear process based on this evidence is given. Experimental results are presented showing the wear of various cemented carbides under both laboratory (simulated) and actual (field) cutting conditions. The improvement in performance associated with the modification of the composition of the binder predicted from the analysis and measured through (simulated) wear tests agreed well with actual (field) test data. Specifically, a fivefold increase in tool life was obtained through substitution of a chromium/cobalt binder for a standard 6% cobalt binder.

Keywords: Tool wear, green wood, cemented carbides

INTRODUCTION

It is estimated that well over half of the large industrial wood surfacers now being sold in the United States are equipped with cutterheads that use cemented carbide tools. These cutting systems have proven to be effective in many applications and often offer the added advantage of providing substantial noise reductions when compared to conventional straight knife high-speed steel cutterheads [Stewart and Hart 1976]. A heavy-duty industrial wood surfer equipped with helical cutterheads is shown in Fig. 1. The cutterhead knives are formed by individual cemented carbide tipped cutters (inserts) approximately 25 mm in length, which abut to form a continuous helical cutting edge.

¹ The authors wish to acknowledge the Newman Machine Company, Inc., for support of this work. The Merillat Corporation of Jackson, Ohio (Mr. John Brunton, Plant Manager) is also acknowledged for participation in the field tests. Special thanks are due Mr. Ron Ferenchak of Merillat, who conducted the field testing program and developed field measurement and data acquisition techniques. The authors also thank Ms. Jo Ann Rattey for the preparation of this manuscript.

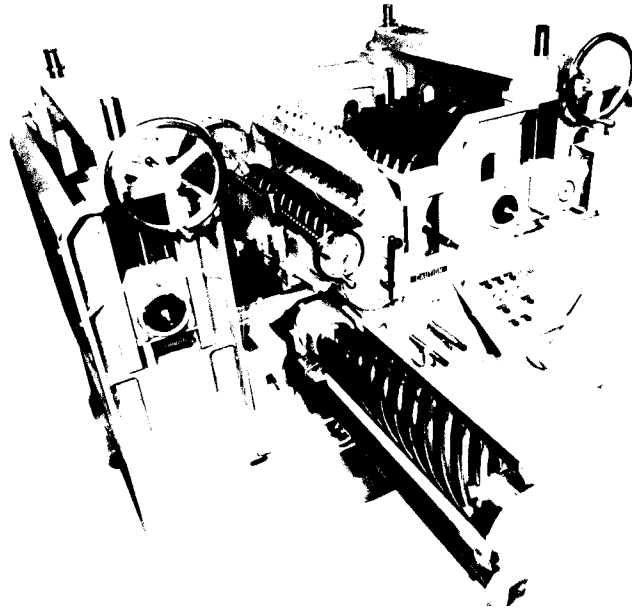

FIG. 1. Industrial wood surfacer equipped with helical carbide cutterheads.

A major shortcoming of conventional carbide tooling for wood surfacers has been the uncharacteristically rapid wear of the cutting edge when cutting green lumber. The work reported here, which was begun in 1976, describes the basic wear mechanisms and the effect of carbide binder composition modifications on performance when surfacing green lumber. This paper consolidates the main results of earlier publications on this subject by the authors and reports the results of extensive field tests.

PRELIMINARY OBSERVATIONS

The operation of interest involves the surfacing (peripheral milling) of hardwood (specifically Appalachian red oak), which consists of removing sufficient material from each side of a rough-sawn piece of lumber to produce a smooth surface (usually 1- to 2-mm material removal) at feed speeds of approximately 1 m/sec. The operation is performed on heavy-duty industrial wood surfacers that incorporate top and bottom cylindrical cutterhead typically containing 6 to 10 rows of knives (see Fig. 1). Peripheral speeds of the cutterheads are usually in the range from 30 to 40 m/sec.

An optical microscopic examination of carbide cutting tools that were used in cutting green oak showed a severe rounding of the cutting edge [Bailey et al. 1983]. More detailed examination (using scanning electron microscopy) shows irregularly shaped grains of tungsten carbide in relief [Bailey et al. 1983; Kirbach and Chow 1976; Bayoumi et al. 1983]. These results and observations have been supported and modeled by Sugihara (1961); Sugihara et al. (1979); Tsai and Klamecki (1980); Hills and McKenzie (1964); and Krilov and Gref (1986). It was apparent from the examination that the binder had been removed from the interstices between

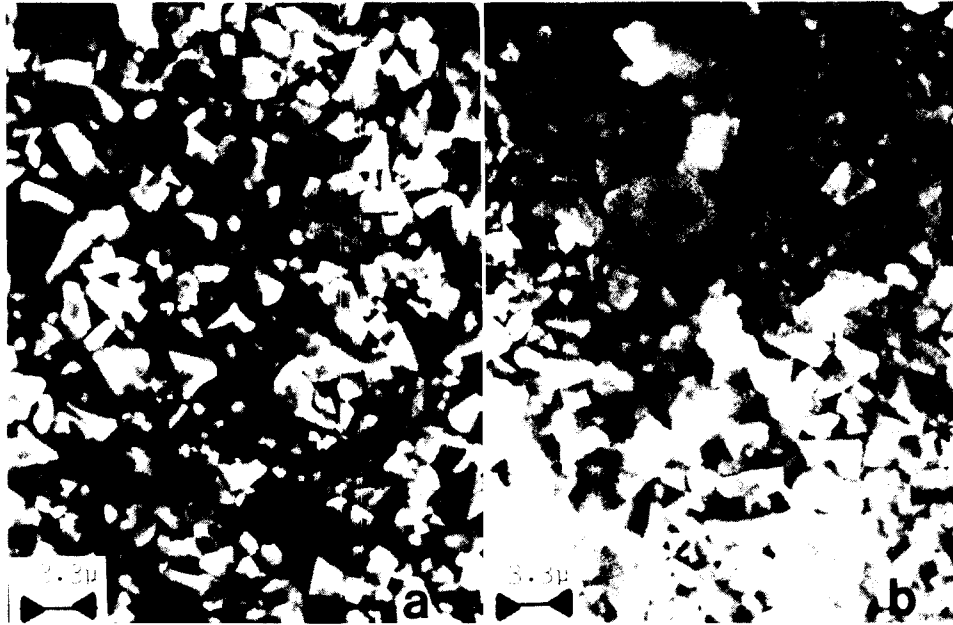

FIG. 2. Comparison of wear for tool operation in cutting (a) green oak and (b) dry oak lumber [Bailey et al. 1983].

the tungsten carbide grains during cutting. Similar observations of carbide tips used in cutting dry oak showed some similarities, i.e., some tool rounding and the presence of angular carbide grains in relief; however, the binder material appeared to have been removed primarily by abrasion as opposed to a corrosion mechanism of removal. Scanning electron photomicrographs of tools used in cutting green and dry oak are shown in Fig. 2 [Bailey et al. 1983].

In order to substantiate removal of the binder material by chemical attack (corrosion), experiments were conducted to determine if a significant chemical reaction occurred between pure cobalt and either a 1.0 normal aqueous solution of tannic acid (present in red oak) or an aqueous solution of digested red oak [Bailey et al. 1983]. In these experiments, pieces of pure cobalt weighing 3 grams were heated to 60 C in agitated aqueous solutions and then were removed and weighed periodically every 4 hours until a total reaction time of 128 hours was attained. The results of these experiments are shown in Fig. 3. It can be seen that the weight loss increases linearly with time. For the aqueous solution of digested oak, a considerable incubation period is required before dissolution of cobalt begins.

On the basis of preliminary observations, it was proposed that the wear of cemented tungsten carbide during cutting green wood occurs primarily by the preferential dissolution of the binder (cobalt) through chemical attack by extractives present in oak (tannins). This is followed by the loss of individual grains of tungsten carbide when the strength of the remaining bond between them and the binder is insufficient to resist the action of the shear forces generated by motion of the chip and the freshly cut workpiece surface over the faces of the tool.

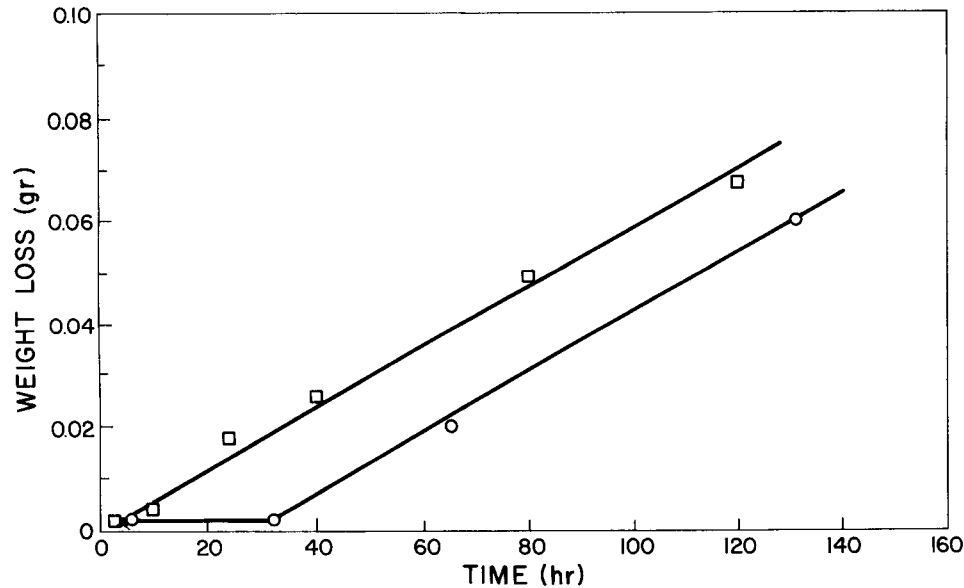

FIG. 3. Weight loss as a function of time for pure cobalt in aqueous solutions of 1.0 N tannic acid (□) and of digested oak (○) at 60 °C [Bailey et al. 1983].

ANALYSIS OF TOOL WEAR MECHANISMS

The analysis of tool wear occurring during the cutting of green oak is based on the wear mechanism described above, which proposed that the primary wear mechanism involved the removal of the binder surrounding the carbide grains by chemical attack. In the theoretical analysis described here, the wear of carbide tools is idealized as a two-stage process involving chemical dissolution of a layer of the binder followed by removal of a layer of carbide grains and a small amount of binder by mechanical action, as illustrated in Figs. 4 and 5 [Bayoumi and Bailey 1984].

The assumptions made in the analysis are:

1. The carbide particles are inert, rigid, and identical spheres of average diameter d , and arranged in a body-centered cubic array with an average interparticle spacing between adjacent corner particles of p (Fig. 5).
2. The organic acid removes the binder from around the carbide particles in a uniform and continuous manner.
3. After a critical time (t_c), the carbide particles are suddenly removed mechanically.
4. The concentration of the organic acid is constant.
5. The products of chemical reaction are removed continuously.
6. When the carbide particles are detached from the binder matrix, failure occurs by a process of shear at the binder-particle interface.

Assuming a first-order reaction representing dissolution of the binder where the time rate of change of the binder volume is equal to the product of the binder

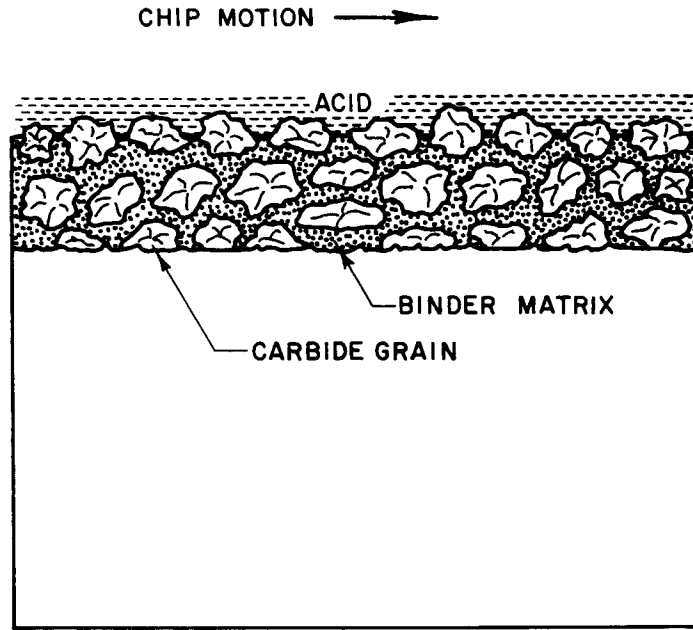

FIG. 4. Schematic representation of the cemented carbide structure.

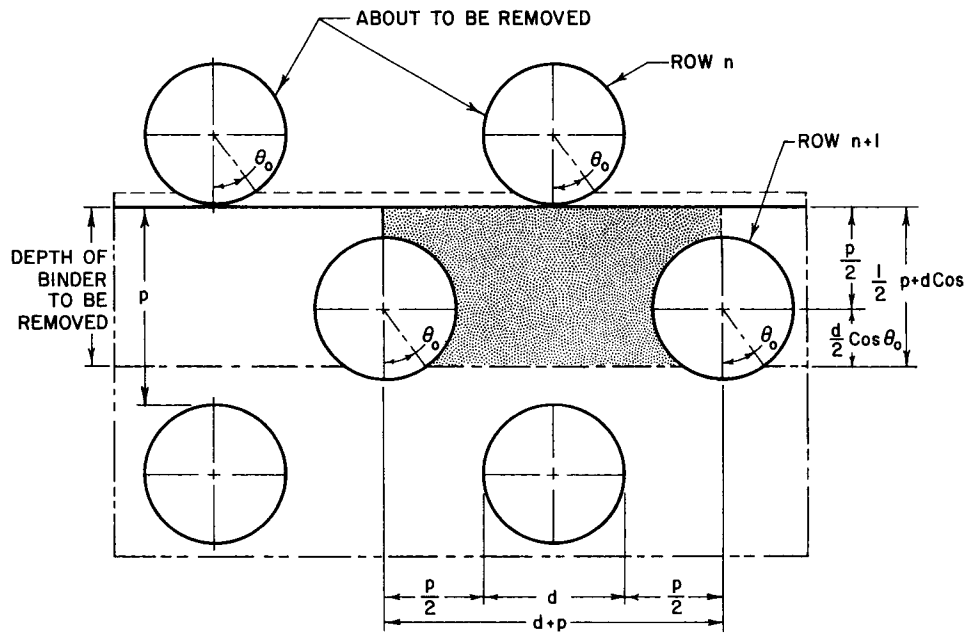

FIG. 5. Idealized model of the cemented carbide structure (b.c.c. arrangement).

volume and the rate constant (k), the time needed to remove a unit layer of binder is [Bayoumi and Bailey 1984]:

$$t_c = \frac{1}{k} \ln \left\{ \frac{144p(d+p)^2(p+d \cos \theta_0)}{\pi d^3(3p+d)(8+9 \cos \theta_0 \cos 3\theta_0) - 48d(p+d)^2(p+d \cos \theta_0)} \right\} \quad (1)$$

where θ_0 is the critical angle at which a layer of grains is removed from the cemented carbide which is taken as:

$$\theta_0 = \cos^{-1} \left(1 - \frac{2F_{sg}}{\pi \tau_d d^2} \right) \quad (2)$$

The average wear rate during the removal of a layer of grains is:

$$\dot{w} = \frac{d+p}{2t_c} \quad (3)$$

Thus, from Eqs. (1), (2), and (3), the wear rate can be calculated from knowledge of the average interparticle spacing p , the average grain size d , the first-order reaction rate constant k , the ultimate shear strength of the binder-particle interface, τ_b , and the shear force exerted on each carbide particle at the workpiece-tool interface, F_{sg} . For specific grades of cutting tool materials, values of d and p can be determined by quantitative metallography, whereas values of k and F_{sg} can only be determined by additional experiments. In the absence of mechanical wear, e.g., when the surface forces on the cemented carbide are low, wear will occur only by chemical loss of the binder, and the resulting wear rate may be obtained by putting θ_0 equal to zero once the reaction rate constant (k) is determined.

Of particular interest is the effect of binder volume fraction, grain size d , reaction rate constant k and rubbing force on the wear rate. The model shows that the wear increases with increasing reaction rate constant, k , binder volume fraction, rubbing force, and grain size, d . An increase in the binder volume fraction leads to an increase in the shear force that is applied to each carbide particle. An increase in shear force gives an increase in the angle θ_0 , the angle at which the carbide particles are removed mechanically. This leads to a decrease in the critical time t_c and to an increase in wear rate. An increase in the first-order reaction rate constant, k , will clearly lead to an increase in the rate of removal of the binder and thus to an increase in wear rate. An increase in the normal force at the tool-workpiece interface, will lead to an increase in F_{sg} , the shear force exerted on each grain. This, in turn, will lead to an increase in θ_0 , a decrease in t_c , and an increase in wear rate. It is also noted that an increase in bond strength at the binder-particle interface decreases wear rate.

EXPERIMENTAL WORK

The first step in the wear behavior investigation consisted of an experimental determination of the reaction rate constant, k , for various types of carbide binder materials. Based on this information, the testing of actual cutting tools under simulated field conditions was undertaken.

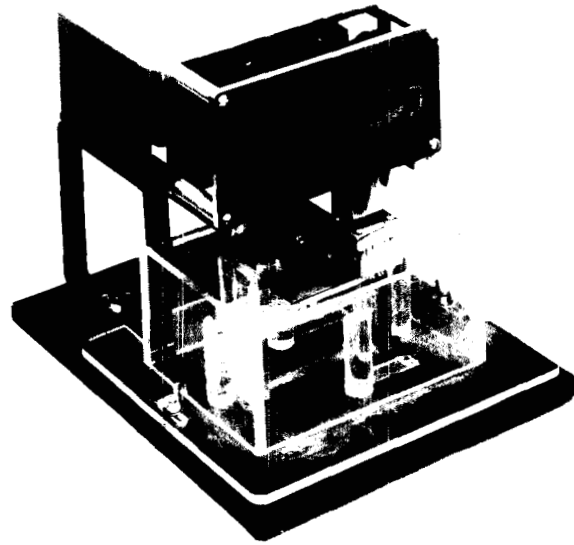

FIG. 6. Photograph of the apparatus used to determine the reaction rate constant [Bayoumi and Bailey 1984].

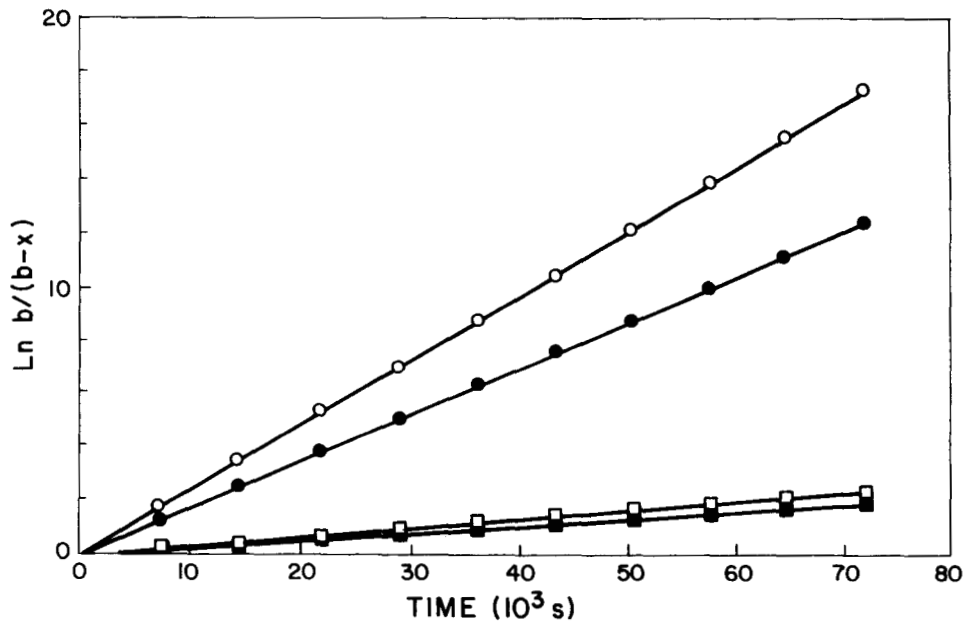

FIG. 7. Chemical reaction kinetics for cobalt and a Co-20%Cr alloy binder with both tannic and acetic acids: O, pure cobalt with tannic acid ($k = 23.6 \times 10^{-5} \text{s}^{-1}$); ●, pure cobalt with acetic acid ($k = 17.2 \times 10^{-5} \text{s}^{-1}$); □, 80% Co-20%Cr with tannic acid ($k = 3.1 \times 10^{-5} \text{s}^{-1}$); ■, 80%Co-20%Cr with acetic acid ($k = 2.5 \times 10^{-5} \text{s}^{-1}$) [Bayoumi and Bailey 1984].

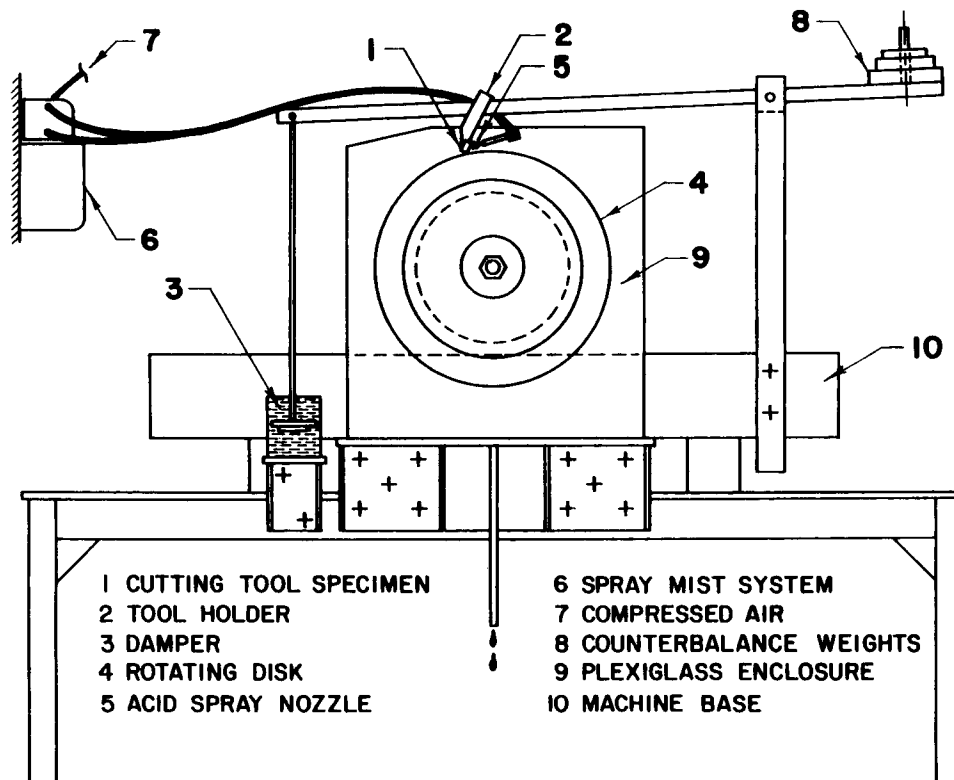

FIG. 8. Wear simulation apparatus.

Determination of the reaction rate constant

The reaction rate constant, k , was shown in the previous section to govern the chemical attack of the carbide binder material. The reaction rate constant investigation was focused on conventional cobalt binder materials and on alternative binder materials believed to be more resistant to acid attack based on chemical composition.

Figure 6 is a photograph of the test apparatus used to determine the reaction rate constant. This apparatus consists of an oscillating nylon brush that continuously scrubs the test material with a diluted aqueous solution of acid, thereby keeping the surface free of the products of reaction. Two binder materials were used, namely, pure cobalt and a cobalt alloy containing 20 wt.% of chromium. The acid was replenished at intervals of two hours, at which time the specimen was weighed.

Figure 7 shows a graph of the natural logarithm of the ratio of the initial volume (or weight) of the specimen to the remaining volume (or weight) of the specimen as a function of time for the reaction of pure cobalt and an 80% cobalt-20% chromium alloy (binders) with both tannic acid and acetic acid for various acid concentrations. It can be seen that linear relationships are obtained for both binders, indicating that the reaction is first-order. The slope of the graphs is the reaction rate constant $k(s^{-1})$.

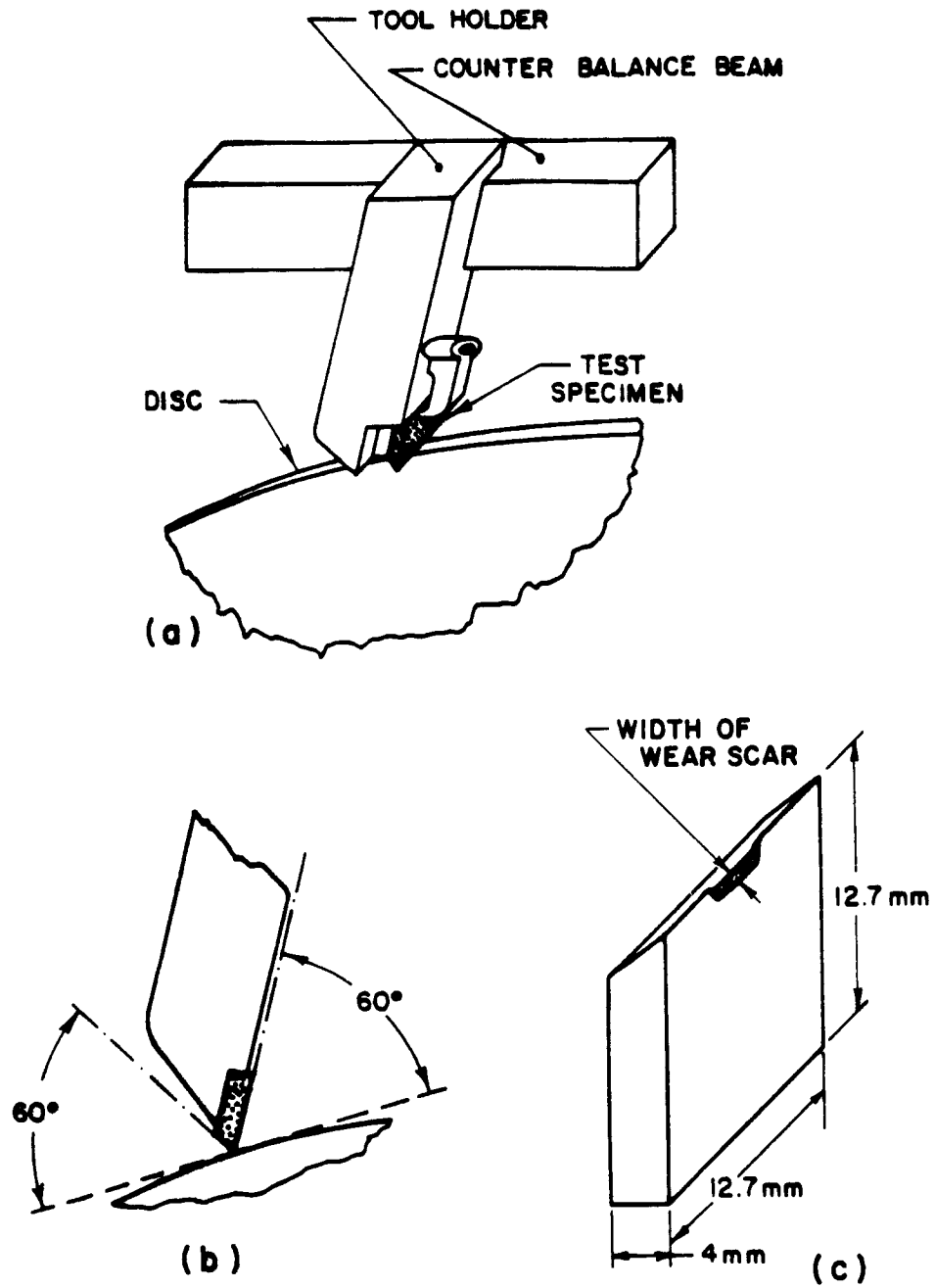

FIG. 9. Test specimen: (a) tool holder; (b) specimen orientation; (c) wear surface [Bayoumi et al. 1983].

TABLE 1. Chemical composition and important property data for cutting tool materials used in the investigation (General Electric Company) [Brooks (ed), 1979].

Grade	Composition (wt.%)				Properties				
	WC	Co	Cr	Ni	Rockwell hardness (HR _c)	Density (g cm ⁻³)	Transverse rupture strength (GN m ⁻²)	Modulus of elasticity (GN m ⁻²)	Average carbide particle size (μm)
GE999	97.0	3.0			93.1	15.3	1.586	652.9	
GE883	94.0	6.0			92.1	14.95	1.999	613.6	1.25
GE44A	94.0	6.0			91.2	14.95	2.206	612.2	1.70
GEX6012	87.5	10.0	2.5		92.2	14.3	1.517	549.2	1.00
GEX7109	82.0	16.0	2.0		89.9	13.8	1.930	495.7	
GE616	82.0	2.0		16.0	87.8	13.95	2.413	518.5	
GEX7125-TC3	87.5	10.0	2.5		91.3				1.40
TEX7125-TC1	87.5	10.0	2.5		91.0				1.60

Figure 7 shows a significant difference in the chemical reaction kinetics when chromium is alloyed with cobalt, which indicates that significant improvement in cemented carbide tool performance in cutting green lumber may be possible by using cobalt-chromium alloy binders.

Experimental evaluation of wear characteristics

Based on the results of the reaction rate constant experiments, an actual wear test of various carbide grades was undertaken in the laboratory. The principal requirement in the design of the test apparatus was the production of relative motion (sliding) between a candidate tool material and a simulated workpiece (wood) within the approximate range of surface speeds encountered in production and under various environmental conditions. A schematic diagram of the wear simulation apparatus is shown in Fig. 8. It consists of a fiberboard disc, 0.45 m in diameter and 5 mm wide, attached to a 1.4-kW electric motor mounted on a heavy steel base. The test specimen is clamped in a special tool holder that is, in turn, attached to a counterbalanced beam. The tool holder is positioned so that only one edge of the test specimen is in contact with the disc as shown in Fig. 9. Adjustable counterbalancing weights are attached to one end of the beam which allow the force between the disc and the test specimen to be varied. An oil drum dashpot is attached to the other end of the counterbalanced beam and is used to minimize vibration in the system.

The apparatus is fitted with a compressed air atomizer that can spray a mist of an extractive (dilute acid) into the region of contact between the test specimen and the rotating disc. The disc and test specimen are contained in a Plexiglas enclosure that is fitted with an exhaust fan and appropriate ducting in order to remove excess mist.

The test specimens used in this work were standard rectangular cutting tool inserts 12.7 mm × 12.7 mm × 3.48 mm in size (Fig. 9). The inserts were selected from three manufacturers, namely General Electric Company, Kennametal Incorporated, and Fansteel VR/Wesson Company. The nominal compositions and important property data for the inserts are given in Tables 1, 2, and 3.

TABLE 2. Chemical composition and important property data for cutting tool materials used in the investigation (Kennametal Incorporated) [Brooks (ed.), 1979].

Grade	Composition (wt.%)							Properties			
	WC	Co	Cr	Ni	TaC	NbC	TiC	Rockwell hardness (HR _c)	Density (g cm ⁻³)	Transverse rupture strength (GN m ⁻²)	Modulus of elasticity (GN m ⁻²)
K602	98.5	1.5						94.3	15.3	0.827	590.2
K703	93.0	6.0	1.0					91.5	14.7	1.724	627.4
K714	83.6	6.3	1.0					92.5	13.1	1.379	548.1
K801	93.2	0.5		6.3				90.9	14.8	1.724	617.8
K3833	89.0	11.0						89.3	14.3	2.758	560.5
K68	94.4	5.6						92.6	14.9	1.724	619.1

Experimental procedure

Tests were carried out by allowing the test specimen to rub against the edge of the rotating fiberboard disc either in the presence (wet) or in the absence (dry) of a mist spray of dilute organic acids (0.2 N acetic acid and 0.1 N tannic acid). These tests were carried out in order to simulate the cutting of green wood having a high moisture content (green) and the cutting of wood with a low moisture content (dried). The rotational frequency of the fiberboard disc was 30 s⁻¹, which gave a relative sliding velocity of 42.4 m/sec, which is close to the velocity experienced in practice. The counterbalancing weight was adjusted to give a contact force of 75 N between the test specimen and the disc.

Sliding under both wet and dry conditions led to the development of a flat wear surface on the edge of the test specimen. This is shown schematically in Fig. 9. The width of the wear surface was measured for each hour of sliding time on a Vickers M55 metallograph until a total of 12 hours of sliding time was accumulated. All the selected tool materials were tested under dry sliding conditions (no acid injection) and wet sliding conditions using a 0.1 N aqueous solution of tannic acid.

RESULTS

Eighteen grades of cemented carbide produced by the three manufacturers were tested under both dry and wet (tannic acid and acetic acid) sliding conditions. The carbides selected included cemented tungsten carbides having binders com-

TABLE 3. Chemical composition and important property data for cutting tool materials used in the investigation (Fansteel VR/Wesson Company) [Brooks (ed.), 1979].

Grade	Composition (wt.%)						Properties		
	WC	Co	Cr ₃ C ₂	TiC	Mo ₂ C	Ni	Rockwell hardness (HR _c)	Density (g cm ⁻³)	Transverse rupture strength (GN m ⁻²)
VR24	82.0	18.0					88.7	13.76	3.275
VR54	92.5	7.0	0.5				92.3	14.70	1.896
W588				67.0	15.0	18.0	91.3	6.04	1.655
Ramet 1	89.5	0.5					91.5	14.50	2.758

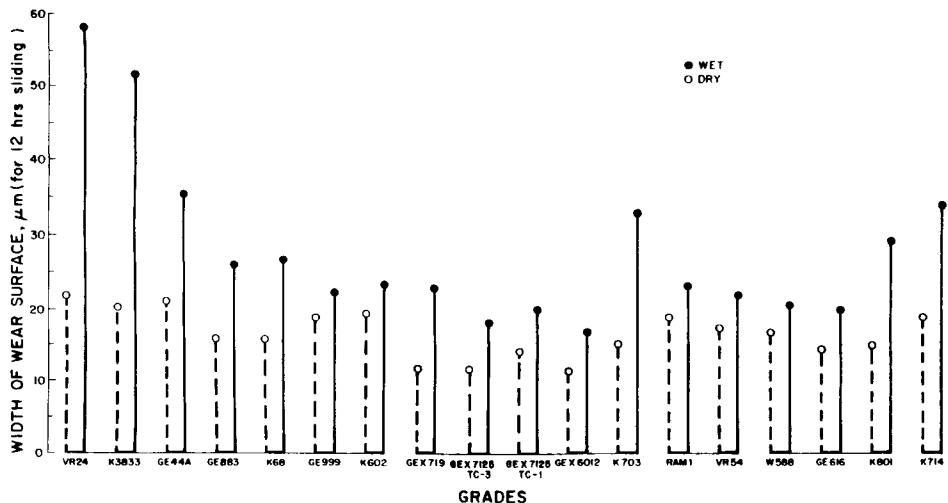

FIG. 10. Effect of chemical composition on wear. Dry sliding conditions and wet sliding conditions (0.1 normal solution tannic acid) [Bayoumi et al. 1983].

posed of cobalt, cobalt and chromium, cobalt and nickel, nickel and chromium, cobalt and chromium carbide, and a titanium carbide alloy with a nickel-molybdenum binder. The 18 grades are grouped in Fig. 10, which shows the wear scar resulting from 12 hours of sliding under both dry and wet (tannic acid) sliding conditions.

The manner in which the wear progresses with time is also of interest since the slope of the wear-time curve is essential in predicting wear surfaces for longer sliding times. Figures 11 and 12 show the growth of the wear surface as a function of time for several materials manufactured by the General Electric Company (Carboloy).

It can be seen from Figs. 10, 11, and 12 that (i) the width of the wear surface increases with an increase in sliding time (distance), but at a decreasing rate; (ii) there is a significant difference in the behavior of the various grades that depends on both the amount and the type of binder present; and (iii) wear under wet sliding conditions is greater than that under dry sliding conditions, for a given sliding time (distance).

Much of the data for wet (tannic acid) sliding conditions (K602, GE999, GE44A, K703, K801, K68, GE883, K3833, K714 and VR24) indicates that the resistance to wear as determined by the width of the wear surface decreases with an increase in binder content in an approximately linear manner. An increase in the amount of binder produces an increase in the interparticle (carbide) spacing. It is believed that this increases the ability of the extractive to penetrate the interstices between the carbide grains and to produce chemical reaction. In addition, removal of the products of chemical reaction will become progressively easier as the interparticle (carbide) spacing increases, thus increasing the effective material removal rate.

The remaining data (GEX719, GEX6012, GEX7125-TC1, GEX7125-TC3, Ramet 1, VR54, W588 and GE616) do not fit the general trend of the results.

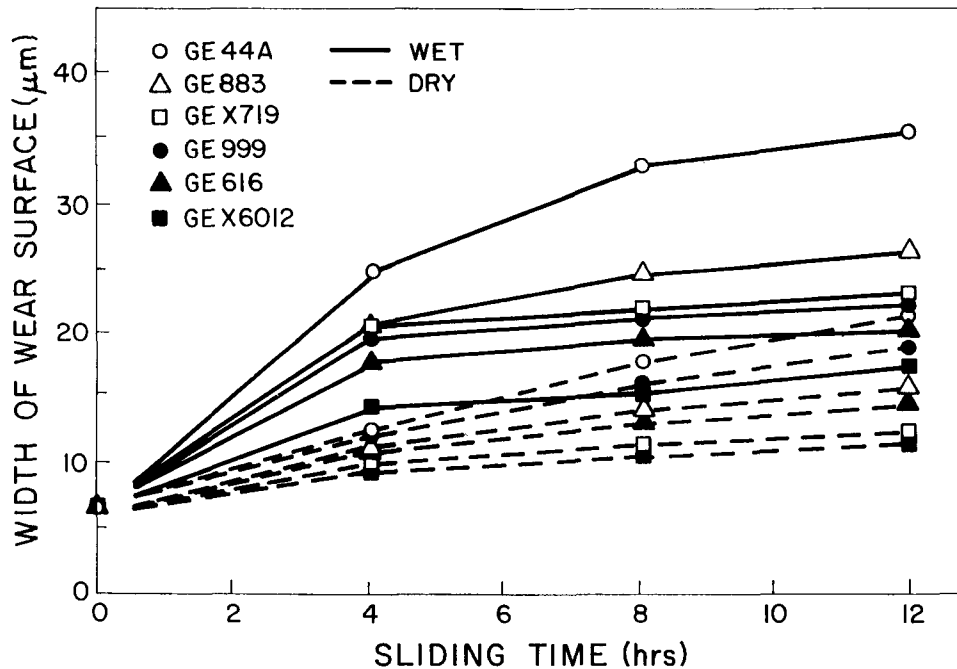

FIG. 11. Growth of the width of the wear surface as a function of time for dry sliding conditions and wet (0.1 N solution of tannic acid) sliding conditions for General Electric Company materials [Bayoumi et al. 1983].

These data indicate enhanced resistance to wear. It is evident that the addition of a high proportion of chromium to cobalt (GEX719, GEX6012, GEX7125-TC1 and GEX7125-TC3) has brought about an increase in the resistance to wear when compared with materials with the same amount of pure cobalt binder. It is believed that this occurs because of an increase in the resistance to chemical attack produced by the addition of chromium. Moreover, the addition of chromium carbide (Ramet 1 and VR54) to those cutting tool materials containing cobalt as the primary binder also brings about an improvement in the resistance to wear when compared to materials with a similar cobalt content but with the absence of any additives. This result is surprising because the addition of such carbides would not be expected to influence the chemical stability of the binder.

Partial substitution of cobalt by nickel as the binder (K801) produces little change in the wear rate, as may be expected from the similarities in properties between nickel and cobalt. When chromium (GE616) or molybdenum carbide (W588) is added to those materials where nickel is used as the primary binder, a significant improvement in wear resistance is produced. It is believed that the addition of chromium assists in increasing the resistance to chemical attack (GE616). It is also evident that the addition of carbides of titanium, tantalum, and niobium (K714) do not affect resistance to wear, a result that may be expected.

Several samples (Kennametal K68) from the wear simulation tests that were carried out under both wet and dry sliding conditions were examined using a JSM II scanning electron microscope over a wide range of magnifications in order to determine the general characteristics of the worn surfaces. Samples of the same

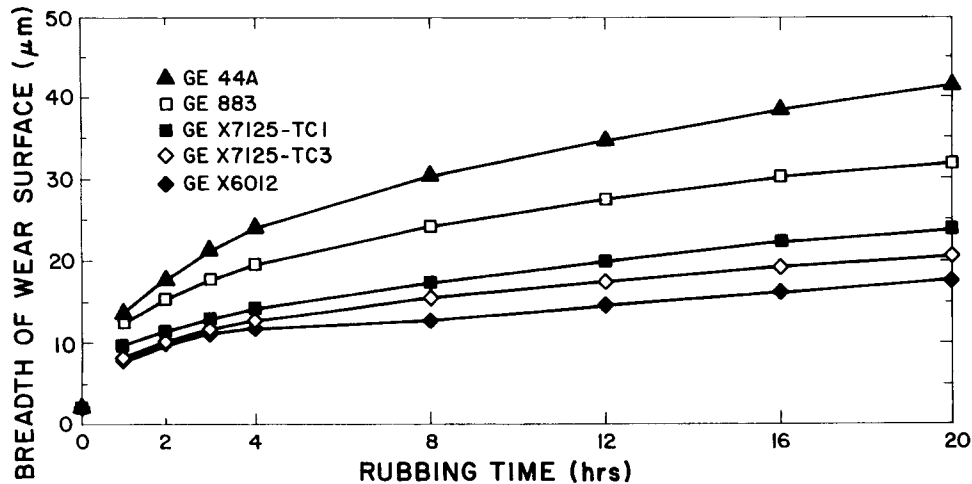

FIG. 12. Growth of the width of the wear surface as a function of time for dry sliding conditions and wet (0.1 N of tannic acid) sliding conditions for General Electric Company materials [Bayoumi and Bailey 1984].

material (Kennametal K68) that had been used in service for cutting green wood and dry wood were retrieved and were also examined on the scanning electron microscope.

Figure 13 is a scanning electron photomicrograph of the worn surfaces of cutting tool inserts (K68). The surface shown in Fig. 13(a) was generated from a field test where green oak was surfaced. The tool surface shown in Fig. 13(b) was generated from the corresponding wear simulation test (wet/tannic acid). It can be seen that the appearances of the worn surfaces are very similar, which tends to lend credence to the validity of the simulation tests.

These results are consistent with the conclusions reached in the theoretical analysis presented earlier. Figures 14 and 15 compare theoretical predictions with experimental results for several grades of carbide for operation with acetic acid. In general, the agreement between the theoretical model and experimental results has been good and has provided a reliable means of estimating the time required to generate a specified wear surface width.

FIELD TESTING OF SELECTED CEMENTED CARBIDES

The objective of the field tests was to verify that the improvements in life predicted in the theoretical analysis and determined from wear simulation tests for selected cemented carbides could be reproduced under actual service conditions.

The field test site selected was Merillat Industries Incorporated of Jackson, Ohio. This facility employs approximately 400 people and is engaged in the manufacture of oak kitchen cabinet components. In order to achieve the desired dimensional characteristics of the lumber, it is surfaced in the green state prior to kiln-drying. The surfacing operation at Merillat is performed on a Newman Model 382 surfer, equipped with helical carbide cutterheads.

The cutterheads rotate at 3550 rpm, are 180 mm in diameter, and have 8 rows

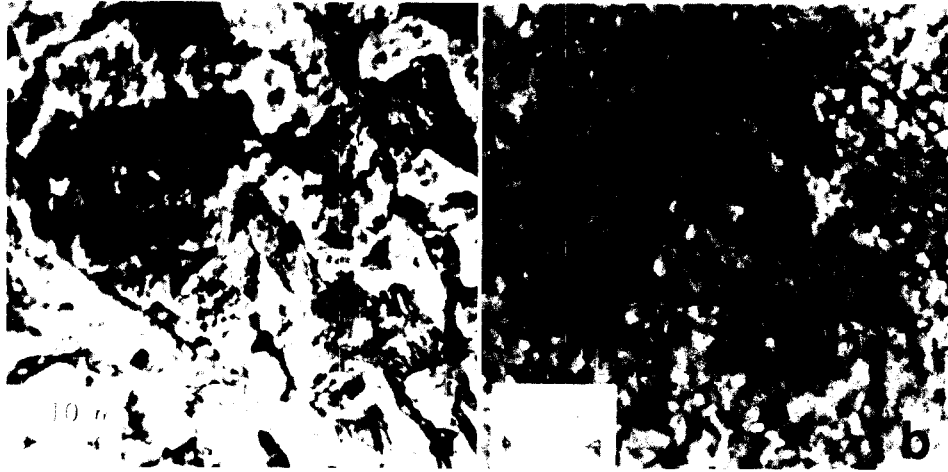

FIG. 13. Scanning electron photomicrographs of worn surfaces of cemented tungsten carbide (K68) tool inserts (a) field use (green oak); (b) simulation test (0.1 N solution of tannic acid) [Bayoumi et al. 1983].

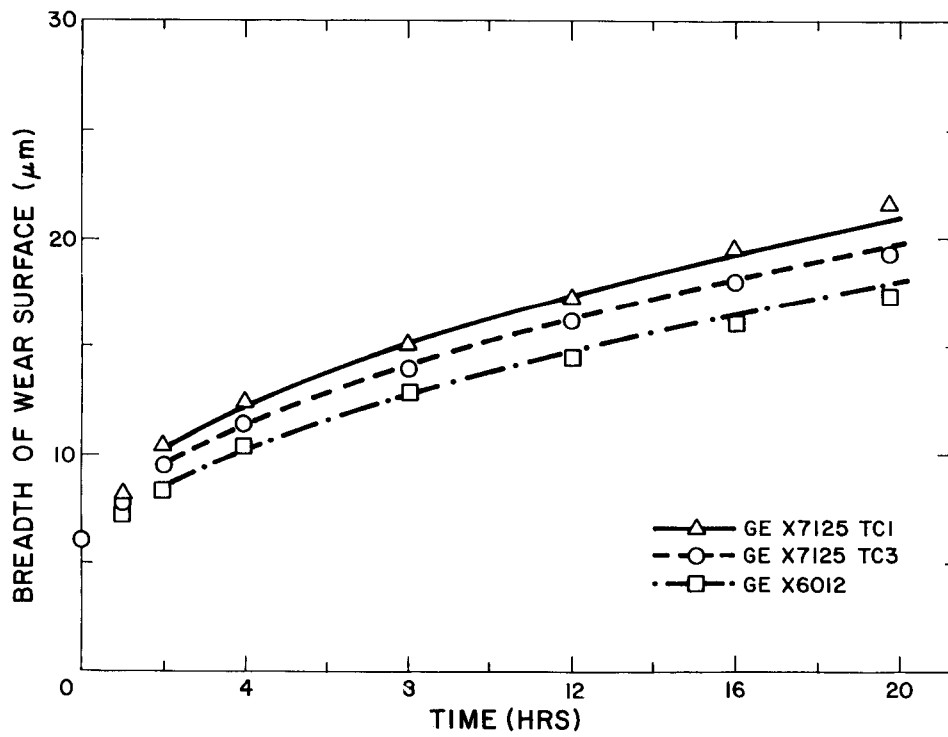

FIG. 14. Comparison of theoretical predictions (—, ---, -·-), with experimental results (Δ, ○, □): □, ---, GE 6012 (acetic; 0, ---, GE X7125 TC3 (acetic acid); Δ, —, GE X7127 TC1 (acetic acid).

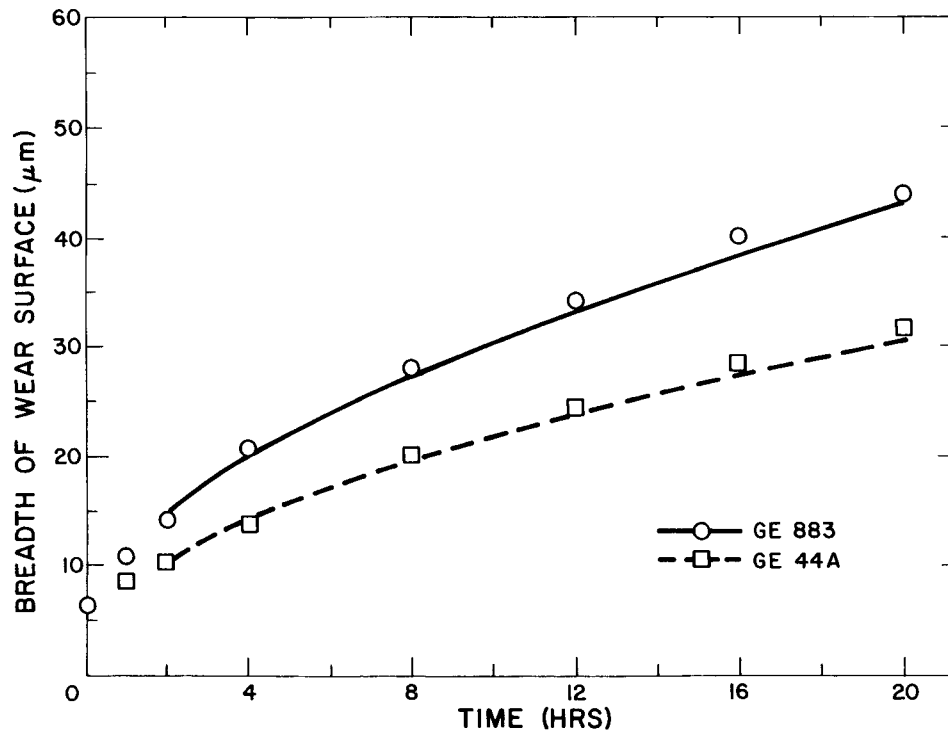

FIG. 15. Comparison of theoretical predictions (—, ---) with experimental results (O, □):□, ---, G883 (acetic acid); 0, —, GE 44A (acetic acid).

of knives formed by individual carbide tipped inserts which abut to form a continuous helical cutting edge. The carbide tip is ground to form the cutting edge at a 15-degree clearance and 15-degree cutting angle. Figure 16 illustrates the cutterhead and carbide tip geometry.

The lumber processed is approximately 25 mm in thickness (nominal) and ranges in width from 100 mm to 300 mm. The lumber is typically fed at a rate of around 1 m/sec. The species surfaced in this operation is exclusively red oak (Appalachian), averaging from 60% to 80% in moisture content. An average of 1.5 mm of material is removed by each cutterhead. The Merillat operation is such that approximately 17,000 linear meters of lumber are processed per shift.

The field test consisted of comparing performance characteristics for a conventional cobalt binder carbide (6% total binder) (GE883) and an alloyed binder (12.5% total binder), 10% cobalt and 2.5% chromium (GEX6012). The tests were conducted over a two-year period utilizing two separate batches of carbide from the carbide manufacturer. Tests were run with each grade in the upper and lower cutterheads respectively, as well as mixed tests utilizing both types in a single cutterhead. Care was taken to base all conclusions on observations of inserts operating near the center of the machine feed bed to insure that the test inserts had been in continuous use. In the field tests several parameters were considered, including:

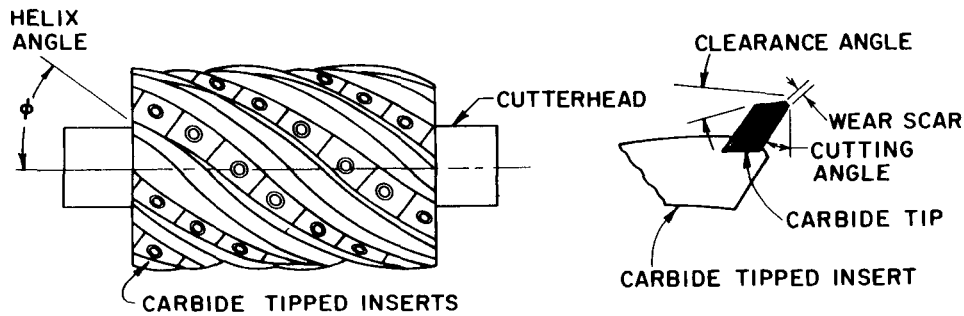

FIG. 16. Helical cutterhead and insert geometry.

- * Permissible dullness (width of the wear scar) for the desired surface finish (see Fig. 16).
- * The cutting distance required to achieve the maximum permissible wear scar, and
- * The amount of carbide removal (grinding) required to return the edge to its original sharpened condition.

Permissible dullness (maximum wear scar)

The permissible dullness is the major determinant of surface quality of lumber and drastically affects the results of the comparison since the wear-cutting distance curves for the two types of carbide under consideration exhibit quite different slopes (Figs. 11 and 12). Thus any difference in performance between the two types of carbide under test would be expected to be less for lower permissible wear scars and greater for larger permissible wear scar values. A measure of wear scar (as shown schematically in Fig. 16) was used by Merillat to establish a tool life criterion. Such a criterion was based on extensive studies and data correlating wear surface, power consumption, and surface finish. A wear surface of approximately $150\ \mu\text{m}$ was selected. The determination of wear surface width was made using a simple $20\times$ stereo microscope and appropriate fixturing for consistently locating the tool tip under the microscope. The surface finish resulting from the $150\text{-}\mu\text{m}$ wear scar was judged by Merillat to be good and more than adequate for the surface quality required prior to kiln-drying. Larger permissible wear scars could be tolerated in some applications based on surface finish quality requirements, provided that adequate power is available for the particular operation.

Cutting distance required to produce the maximum permissible wear scar

The amount of lumber surfaced before the wear scar reached the target value was determined by periodically removing sample inserts and making a microscopic evaluation of the wear scar. In this way the progression of the edge wear could be documented up to the established wear limit. At this point, the clearance face of the inserts was reground using an in-machine grinding attachment equipped with a diamond grinding wheel in order to remove the wear scar and regain the original sharpness condition. The results of two representative wear periods (1 period = freshly ground to maximum dullness permissible) are shown in Fig. 17

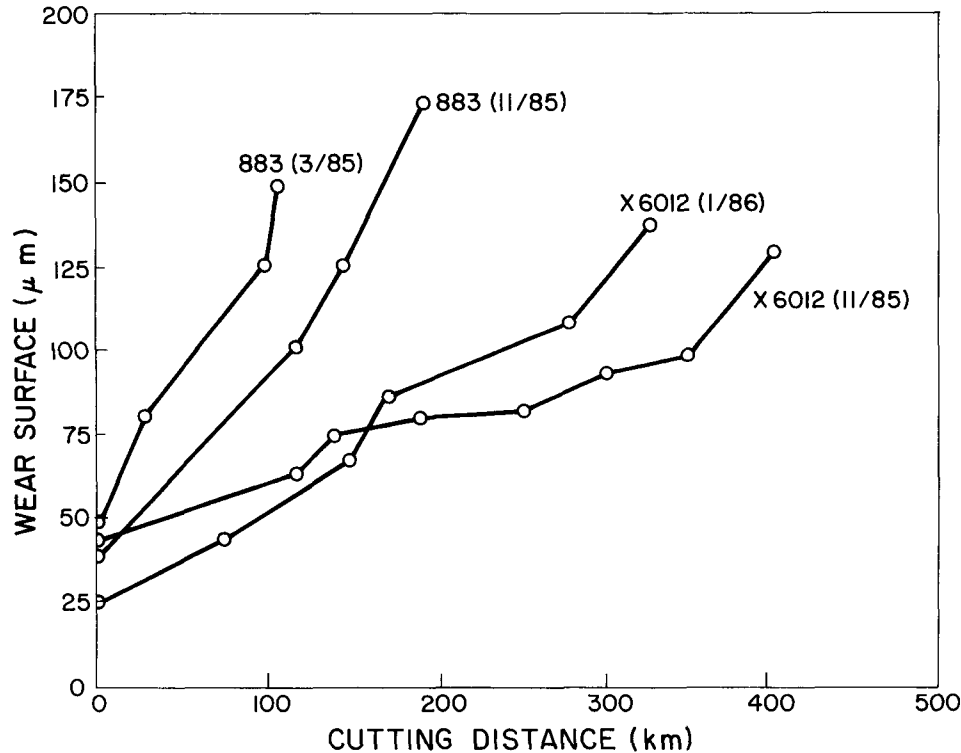

FIG. 17. Typical wear results from field tests of GE883 (6%Co) and GEX6012 (10%Co-2.5%Cr).

for the two carbide grades tested. Similar comparisons were made over the test period, and additional performance graphs for the chromium-cobalt binder carbide have been compiled since both cutterheads were converted to this grade. The typical cutting distance required to reach the 150- μm permissible wear scar was around 400,000 meters for the chromium-cobalt binder and 150,000 meters for the 6% cobalt binder carbide based on data gathered over the two-year field test. Variations in wear behavior, as indicated in Fig. 17, probably result from acid concentration and moisture content variations in the wood.

Carbide removal required to resharpen

Although the interval between regrinding discussed in the preceding paragraph is important to achieve an efficient maintenance procedure, the total number of regrinds possible (which depends on the carbide removed per grind) must be established in order to estimate the actual tool life. This performance characteristic was evaluated by directly measuring the carbide loss resulting from removal of the wear scar by grinding the clearance face of the tool. This was performed using a simple dial indicator set up to measure the carbide tip projection above the insert body before and after regrinding. Figure 18 illustrates the regrinding procedure as well as the technique for measuring loss in tip projection resulting from regrinding the clearance face. The average loss in carbide tip projection due to regrinding was 100 μm for the X6012 (chromium-cobalt binder) and 250 μm

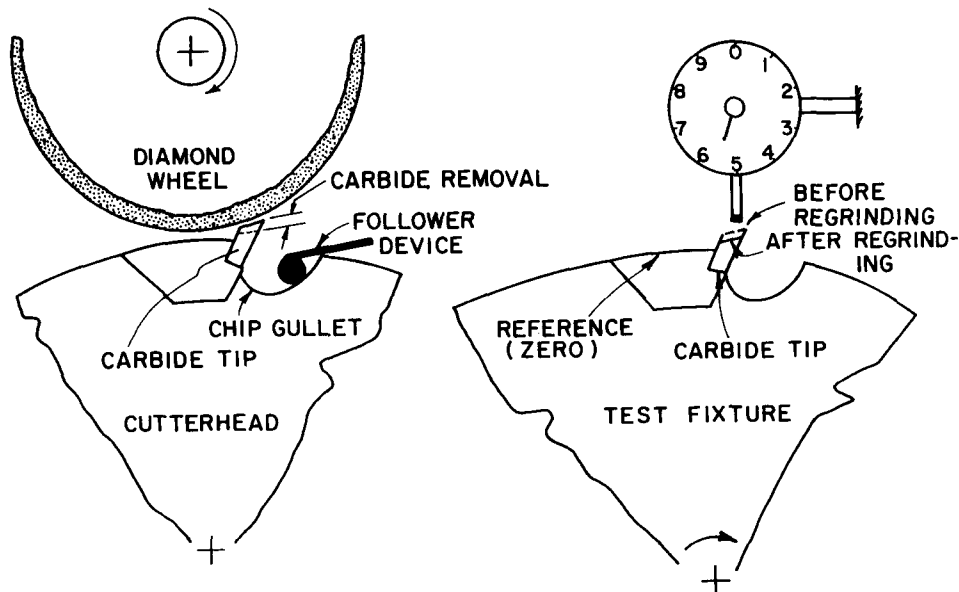

FIG. 18. Illustration of regrinding technique and method for determining carbide removal due to regrinding.

for the 883 (6% cobalt binder) carbide, a result which was anticipated from microscopic examinations of rake face wear for the two grades. These differences would translate into a similar increase (2.5:1) in the number of grinds possible if grinding is done only to the extent required, i.e., excess carbide is not removed.

CONCLUSIONS

The mechanism resulting in accelerated wear when conventional cobalt binder carbides are used to surface green oak lumber has been shown to be preferential attack of the binder material by organic acids in the wood. The corrosion of the binder progressively weakens the bond holding the carbide particles in place until the exposed particles are removed mechanically and the process is repeated.

The simple theoretical model developed seems to adequately predict the wear behavior of cemented carbides when subjected to green wood wherein the major wear mechanism is erosion of the binder material.

In more depth, the following conclusions can be drawn:

1. The experimental results show that for cemented carbides wear resistance increases with (i) the addition of chromium to the binder matrix material and (ii) a decrease in carbide particle size.
2. The predictions of the theoretical model for the effect of grain size and chemical rate constant on wear agree remarkably well with experimental data.
3. The wear rate of carbide in green lumber was shown to depend strongly on the chemical reaction rate between the acids present in the wood and the carbide binder material. This reaction rate can be modified through changes in the binder metallurgy as described in the theoretical analysis.

4. The addition of chromium to the conventional cobalt binder produced a significant improvement in wear performance under both laboratory and field test conditions. For a maximum acceptable wear scar of 150 mm, a 2.5:1 improvement in cutting distance was observed in the field test accompanied by a similar reduction in the amount of carbide removal required for resharpening.

FINAL COMMENT

The projected improvement in overall carbide tool life (around 5:1) is being duplicated in separate field tests on separate batches of carbide inserts and is considered to be representative for similar operations, i.e., surfacing of green oak prior to drying. Since this increase in wear resistance corresponds to a tool life expectancy of 3–4 years for this test site (depending on plant production), an evaluation based on the complete tool life has not been completed. The improvement to be expected for other cases (other types of wood) can be estimated using the theory presented herein, provided that the types of acids involved, concentration, and reaction rate constant can be determined. In general, the improvement in performance resulting from use of the alloyed binder would be expected to be less for woods containing weak acids and/or woods having a low moisture content.

REFERENCES

- BAILEY, J. A., A. E. BAYOUMI, AND J. S. STEWART. 1983. Wear of some cemented carbide tools in machining oak. *Int. J. Wear* (85):69–79.
- BAYOUMI, A. E., J. A. BAILEY, AND J. S. STEWART. 1983. Comparison of the wear resistance of various grades of cemented carbide that may find application in machining wood. *Int. J. Wear* (89):185–200.
- , AND ———. 1984. Analytical and experimental investigation of wear of cemented carbide in the presence of dilute organic acids. *Int. J. Wear* (94):29–45.
- BROOKS, K. J. A., ed. 1979. *World directory and handbook of hard metals*. Engineering Digest, New York, 2nd edition.
- HILLS, W. E., AND W. M. MCKENZIE. 1964. Chemical attack as a factor in the wear of woodworking cutters. *Forest Prod. J.* 14:310–312.
- KIRBACH, E., AND S. CHOW. 1976. Chemical wear on tungsten carbide cutting tools by Western Redcedar. *For. Prod. J.* 26(3):87.
- KRILOV, A., AND R. GREF. 1986. Mechanism of sawblade corrosion by polyphenolic compounds. *Wood Sci. Technol.* 20:369–375.
- SUGIHARA, H. 1961. Wood cutting. Page 329 in S. Kadita, ed. *Wood technology*, Yoken-Do, Tokyo.
- , S. OKUMURA, M. HOAKA, T. OHI, AND Y. MAKINO. 1979. Wear of tungsten carbide tipped circular saws in cutting particle-board: Effect of carbide grain size on wear characteristics. *Wood Sci. Technol.* 13(4):283–299.
- STEWART, J. S., AND F. D. HART. 1976. Control of industrial wood planer noise through improved cutterhead design. *Noise Control Engineering* 7(1):July–August.
- TSAI, G. S. C., AND B. E. KLAMECKI. 1980. Separation of abrasive and electrochemical tool wear mechanisms in wood cutting. *Wood Science* 12(4):236.