

2012

The effects of teaching style on student learning of DNA

Rebecca Branton

Louisiana State University and Agricultural and Mechanical College

Follow this and additional works at: https://digitalcommons.lsu.edu/gradschool_theses



Part of the [Physical Sciences and Mathematics Commons](#)

Recommended Citation

Branton, Rebecca, "The effects of teaching style on student learning of DNA" (2012). *LSU Master's Theses*. 2345.

https://digitalcommons.lsu.edu/gradschool_theses/2345

This Thesis is brought to you for free and open access by the Graduate School at LSU Digital Commons. It has been accepted for inclusion in LSU Master's Theses by an authorized graduate school editor of LSU Digital Commons. For more information, please contact gradetd@lsu.edu.

THE EFFECTS OF TEACHING STYLE ON STUDENT LEARNING OF DNA

A Thesis

Submitted to the Graduate Faculty of the
Louisiana State University and
Agricultural and Mechanical College
in partial fulfillment of the
requirements for the degree of
Master of Natural Sciences

in

The Interdepartmental Program in Natural Sciences

by
Rebecca Ann Branton
B.S., University of Louisiana - Monroe, 2000
August 2012

ACKNOWLEDGMENTS

I would like to express my sincere appreciation to my committee chair, Dr. Dana Browne, for his guidance and suggestions. To my committee members, Dr. Cyrill Slezak and Dr. Juana Moreno, thank you for pushing me to challenge myself. Without their support and advice, this thesis would not have been possible.

To my MNS family, the past three years have been a struggle but you have all been here for me and I greatly appreciate it. I could not have completed this thesis without the laughter, constructive criticism, discussions, editing, and mutual frustration we had together. To my parents, David and Cyndy Branton, thank you for your constant support and words of encouragement throughout this process.

TABLE OF CONTENTS

Acknowledgments	ii
Abstract	v
Introduction	6
Literature Review	8
Materials and Methods	13
Experimental Group – Inquiry Based Learning	14
Control Group – Traditional Style Learning	17
Data and Analysis	21
Does it make a difference whether students were in an honors class rather than an academic class?	22
Does gender make a difference when comparing instructional format?.....	24
Does instructional format make a difference in unit test scores and/or in final course grades?.....	26
Conclusions.....	31
References.....	34
Appendix A: Outline of Procedure	35
Appendix B: Pretest/Posttest.....	36
Appendix C: Vocabulary terms	40
Appendix D: DNA Strawberry Extraction Lab	41
Appendix E: DNA Replication Worksheet.....	43
Appendix F: DNA Unit Test Study Guide.....	44
Appendix G: DNA Unit test	45
Appendix H: Traditional Group DNA PowerPoint	51
Appendix I: Traditional Group DNA Guided Notes	53

Appendix J: Traditional group – DNA Model	55
Appendix K: Traditional Group DNA Replication Notes PowerPoint	57
Appendix L: DNA Replication Guided Notes	58
Appendix M: Traditional Group RNA Notes PowerPoint.....	59
Appendix N: Traditional Group RNA Guided Notes	61
Appendix O: Traditional Group Translation and Transcription PowerPoint	62
Appendix P: Translation Guided Notes	64
Appendix Q: IRB Exemption Documentation.....	66
Vita	67

ABSTRACT

New methods and practices are constantly being introduced in education due to new research that emerges as a push for student achievement increases. We as teachers must adapt to these new ideas to ensure student success. This study was completed to determine if inquiry-based teaching methods would be more beneficial in learning Biology concepts than traditional lecture instruction. The students were divided into two groups, which differed based solely on their instructional format. The activities involved in this study included inquiry-based activities and traditional activities, i.e. Power Points, guided notes, experiments and worksheets. The participants in this study, students in a ninth grade Biology class, were given a pretest to assess prior knowledge of the unit on DNA that would be covered in the classroom lessons. The same assessment was also administered at the completion of the unit to measure learning gain.

The instructional format of the material given showed an effect on learner outcomes. In general, there was a significant difference in the mean posttest scores. However, further analysis showed this difference was between honors students and academic students. When comparing unit test scores, inquiry students' scores were significantly higher than the traditional lecture students. If inquiry activities are executed properly, implementing them into the Biology curriculum can increase learning gains of Biology topics.

INTRODUCTION

A constant struggle for teachers in all disciplines of education is to ensure that students not only understand the concepts and skills that they are taught, but also that they can then analyze and apply those tools to different situations that arise. Because Biology is a subject that relies heavily on rote memorization, it has traditionally been taught through the use of lectures, note taking, and supplemental laboratory activities. Education is a continually changing discipline; new research is constantly considering new methods to improve student gains in the classroom and increase overall knowledge retention. In order for students to be successful in school and in life, teachers need to constantly revise their teaching practices based on new methods that are introduced in order to ensure that students are engaged, invested, and increasing their academic achievements.

One method that has been found to produce strong results in student achievement is teaching by inquiry. When I first began my journey as an LSU graduate student participating in the LaMSTI program, I had never experienced a class that used inquiry-based activities as a teaching tool. After completing the Physics by Inquiry course in Summer 2010, I felt I had a better understanding of physics concepts than I ever had during my high school Physics course. The Chemistry Modeling program from Summer 2011 also helped me to understand the basic concepts much better than I had before. The hands-on activities utilized were more interesting, more engaging, and increased my confidence as I began to discover information on my own. I was extremely impressed with the way inquiry and Modeling helped me to understand these concepts,

while at the same time they held my interest enough so that I was invested in my own learning.

After experiencing such success in Physics and Chemistry, I was curious to know if these inquiry-based activities could be applied to Biology classes so that my students could feel the same level of success that I had. In my classroom, I currently do numerous lab activities throughout the year, but not necessarily in an inquiry-based fashion. The majority of my instruction relies on lectures and note taking; inquiry-based activities would probably increase student engagement as well as reach out to different types of learners. Although Biology does involve so much direct memorization, students may still be able to benefit from more hands-on activities and self-discovery, rather than teacher-led lessons. The topic of DNA is one that students constantly struggle with as it is such an intangible concept that students have a hard time grasping it. An analysis of student gains on the Genetic Concept Inventory between a group of traditionally-taught students and a group of students taught by inquiry-based methods will show if there are positive effects of inquiry in the realm of Biology.

LITERATURE REVIEW

The use of inquiry-based activities in science seems to be more advanced in the areas of Physics and Chemistry, although Biology is catching up. Physics courses have been able to use the Force Concept Inventory since 1992 as an effective assessment tool that measures changes in conceptual understanding within an active learning environment (Savinainen, Scott, 2002). Research also shows that traditional styles of teaching are doing little to improve the conceptual learning in Physics (Halloun, Hestenes, 1985). A study from 1998 used students in introductory Physics courses on the high school and college level to compare interactive engagement methods to traditional methods in order to see an effect on student gains. Interactive engagement (IE) methods, i.e. inquiry-based methods, are defined as those “designed at least in part to promote conceptual understanding through interactive engagement of students in heads-on (always) and hands-on (usually) activities which yield immediate feedback through discussion with peers and/or instructors,” all as judged by their literature descriptions; Traditional courses are those reported by instructors to “make little or no use of Interactive Engagement methods, relying primarily on passive-student lectures, recipe labs, and algorithmic problem exams” (Hake, 1998). Results showed higher gains in the interactive engagement classes rather than the traditional classes. Results also showed higher gains when using a conceptual based assessment, such as Mechanics Baseline test of Hestenes-Wells, which implies interactive engagement strategies enhance problem-solving ability. Overall data showed “the conceptual test results strongly suggest that the use of IE strategies can increase mechanics-course

effectiveness well beyond that obtained with traditional methods” (Hake, 1998). Inquiry-based activities are showing a difference in student learning in Physics courses.

Although a multitude of research has been done to show the positive benefits of inquiry-based activities or achievement in Physics, this depth of research is lacking regarding Biology courses. The majority of Biology learning is primarily rote memorization; students either know the basic concepts and vocabulary or they do not. As freshman in high school, many students do not have the study skills or maturity level to be successful in memorizing the wealth of information they need in order to be successful. Since inquiry-based methods have been so successful in other science courses, an analysis of their effects on student knowledge gains in Biology as compared to traditional teaching methods would be beneficial to the academic community as a whole.

Most literature found on inquiry-based instruction in Biology involves introductory college courses, rather than a high school setting. A study performed by Wilden et al., (2002), concerned students at the University of Nevada, Reno. The researchers compared two Biology courses - one an introductory course (Biology 100 – Principles and Applications of Biology) for non-science majors while the other one was a newly created course (Biology 110 – Biology for Education Majors) designed for Elementary Education majors. The Biology 100 group was further divided into non-science majors (n=194) and Elementary Education majors (n=14), while the Biology 110 was composed only of Elementary Education students (n=15). The course for non-science majors was taught in a traditional lecture and laboratory format, while the course for the education majors was strictly taught using inquiry, collaborative work, and investigations. The

same topics were covered in both courses, just in different ways. The assessment used as a pretest and posttest was a modification of the National Association of Biology Teachers (NABT) Content Biology test. Both groups were given the pre-test, participated and completed assignments in the classes taught in the different styles, and then given the same assessment as a posttest. Results concluded by an Analysis of Variance (ANOVA) test showed no significant difference in the pretest scores. Additional statistical tests showed a significant difference only between the Biology 110 inquiry-based group and the Biology 100 lecture-based group on the posttest. The researchers concluded that inquiry-based instruction was more effective than traditional-based instruction for the students in this study (Wilden et al., 2002). However, the study does not account for any differences in student gains other than for education majors.

Another study done at the University of South Carolina also concerned introductory Biology courses, one taught by lecture and one taught by inquiry methods. Student learning was measured by comparing pretest to posttest scores, which included content knowledge as well as open-ended written responses. In the open-ended responses, students were asked to address a misconception they had at the beginning of the course that was reconciled by the end. The pre/posttest was designed by the university instructors, and was given over five semesters of the same course (n=1493). Results showed that more concrete ideas, such as anatomy and physiology, were better understood with traditional lecture style, whereas abstract topics, such as evolution and biodiversity, showed better results with inquiry based techniques (Timmerman et al., 2010).

One of the topics often addressed in the study of Biology learning is the field of Genetics. A Genetics Concept Inventory (GCI), modeled after the Force Concept Inventory, is being developed in an effort to assess misconceptions most commonly found in this topic. The GCI was initially piloted in a Genetics course of 49 students at California Polytechnic State University and consisted of 38 questions in total: 36 were a mixture of multiple choice, fill in the blank, matching, and true/false, and 2 were short answer questions. The questions included cover a variety of topics, including components of DNA, its structure, how DNA codes for proteins, cell reproduction, and how genes are passed from generation to generation. These piloted GCI questions were posted publicly in a paper titled "Genetics Concept Inventory" (Elrod, 2007). A Genetics Concept Assessment is still in the works as a possible better means to evaluate the misconceptions in genetics, but has not yet been published (Smith et al., 2008).

Overall, while a multitude of research on the relationship between inquiry-based activities and student achievement has been done in the areas of Physics and Chemistry, much of this research is missing regarding Biology. Since a large component of Biology is concerned with the memorization of knowledge and concepts and is not as skill-based as other science disciplines, this missing research is not very surprising. However, there are some specific concepts in Biology where students could benefit more from inquiry-based activities than traditional learning by lecture. Other studies have been completed by looking at college level Biology courses, not many have been conducted on high school students. In addition, most studies have taught using inquiry throughout the course. However, because there is no inquiry curriculum for Biology, the

information is limited to one topic. It would have been better to use the method all year, but there was not an available curriculum. This study seeks to fill this void by focusing on the use of inquiry-based learning as compared to lecture-based learning regarding the concepts and skills needed to have a full understanding of DNA, its structure, and its function.

MATERIALS AND METHODS

This study group consisted of ninth grade students that were taught Biology throughout an entire school year on an A/B schedule. On this type of schedule, students alternate the days on which they go to Biology, meaning that all A day students are seen one day and all B day students are seen the following day. For simplicity, A day students became the experimental group and B day students became the control group. The unit studied was titled DNA and its Structure. On A day, students (n=69) were taught using inquiry-based activities and follow-up worksheets; B day students (n=57) were taught traditionally using lectures, guided notes, and laboratory and supplementary activities. Both populations were taught the same times each day: 2nd, 3rd, and 4th blocks, with 90 minutes in each class period. Third block for both A and B days was interrupted by a 30 minute lunch period, about midway through the 90 minute period. However, one block of A day (2nd block) was an honors class, while the other five classes were academic in nature. Prior knowledge of Biology content was the same for all classes, as all students had taken Life Science in middle school. Intrinsic motivation could be different among the classes, since traditionally honors students are usually more motivated than most academic students; however, this idea was not addressed in these classes prior to this study.

The demographics of my study were comparable to the school's population of ninth grade students. Table 1 shows the demographic breakdown of my study group as compared to the school-wide ninth grade demographics. 49% of students qualify for free or reduced lunch, an indicator of poverty.

Table 1: Demographics of my study group compared to the freshman population

	Caucasian	African American	Hispanic	Other
Total enrolled Freshman	51%	39%	8%	2%
Study Group	51%	40%	8%	2%

The procedure followed was to give a pretest, teach lessons using two different instructional formats, and then follow up with the same pretest as a posttest (Appendix A). The pretest and posttest scores were analyzed to assess which instructional format helped students learn better. For the pre and posttest, a modified Genetics Concept Inventory (GCI) was used for each set of students, consisting of 9 of the 38 piloted GCI questions that pertained to the topic of DNA (Appendix B). Most questions were removed because they did not pertain to our focus on the structure of DNA or had advanced vocabulary that my students would likely not understand, due to the fact that the GCI is geared towards those that are in a Genetics course.

EXPERIMENTAL GROUP – INQUIRY BASED LEARNING

An important aspect necessary to this study was to find inquiry-based activities relating to DNA that would be appropriate for high school students. There is not a specific set of inquiry activities to follow for Biology, since most research on inquiry-based activities applies to Physics and Chemistry only. Therefore, a search was done for inquiry-based activities about DNA and its structure, which produced many

suggestions and links. Activities were chosen based on whether they were tactical, used higher order thinking skills, and were within my students' ability level.

On Day 1, before we began the lesson, students were asked to define terms (Appendix C) from the textbook that they needed to know in order to understand what we would discuss in that lesson. After completing and discussing the daily vocabulary terms, our first activity was to construct a model of DNA (<http://www.mysciencebox.org/DNAmodels>). Students cut out the pieces of the DNA "puzzle". On Day 2, students then observed that there was only one way for the pieces to fit together perfectly. After putting the model together, we were able to discuss that DNA can only fit together in one way, consistently. A follow-up worksheet (<http://smtaylor.wikispaces.com/file/view/DNA+Structure+WS.pdf>) was completed, in groups with teacher guidance, for reviewing the information discussed in the lesson.

On Day 3, vocabulary terms from Day 2 were reviewed and then students completed a lab in which DNA was extracted from a strawberry (Appendix D). Several strawberries were smashed together in a plastic bag. A soapy, salty fluid was added to the smashed strawberries in order to break the bonds that hold the DNA together. This mixture was then filtered into a smaller container removing the large pieces of strawberry. Ice cold isopropyl alcohol was added to separate the DNA from the rest of the mixture, the DNA "floated" to the top of the liquid and students removed it with a toothpick for further inspection. This lab communicated to the students that one strand of DNA is very small, but when many strands are together, the DNA can be seen, much the same way that a single thread cannot be seen from a distance, but multiple threads wound in a rope can be seen from a distance. This lab was used in both the

experimental and control groups, due to the fact it is part of the traditional style as well as inquiry. After the lab, we also completed a worksheet regarding how DNA replicates (Appendix E).

On Day 4, students completed a worksheet assignment correlating with the textbook that explored the structure and function of DNA. They had to use vocabulary we had previously discussed in order to work together to answer questions and solve problems.

On Day 5, students began the lesson by completing the vocabulary necessary to understand the day's main concepts. After discussing the new terms, students completed an activity called Secret Codes (<http://www.mysciencebox.org/secretcodes>), in which they had to decode secret messages; first using Morse code, and again using their own created code. Once they understood how a code worked, the idea was applied to tangible concepts that are coded in life, such as DNA codes to make proteins. Using a worksheet on protein synthesis, the students were given step by step explanations of how DNA replicates, then translates into RNA and then transcribes into amino acids to make proteins using these special codes (http://www.lessonplansinc.com/lessonplans/protein_synthesis_ws.pdf). The worksheet was completed as guided practice, where students worked independently but could ask questions from either myself or their peers.

On Day 6, a review worksheet was completed on Protein Synthesis (<http://home.comcast.net/~clupold96/printables/xproteinsynwk.pdf>) and discussed in class. The next activity was to complete the study guide (Appendix F) for the DNA Unit

Assessment as a class. We worked through this together as a class to ensure that students had the correct answers in case there were questions that were not covered in our inquiry-based activities. On Day 7, students were administered the posttest as well as the DNA test (Appendix G).

CONTROL GROUP – TRADITIONAL STYLE LEARNING

The control groups' method of learning was extremely different from the experimental groups'. This group was taught using lecture and guided notes, as well as worksheets and one lab activity. On Day 1, three activities were completed. First, students defined vocabulary terms for the entire unit on DNA (Appendix C), which would be discussed during the lectures. Secondly, students viewed a PowerPoint (Appendix H) and filled in guided notes (Appendix I) that explained what DNA was and what it is made of. Finally, students completed a worksheet using the textbook, and labeled the components found in DNA's structure.

On Day 2, we reviewed the DNA worksheet from Day 1 and students were encouraged to correct their wrong answers. The next activity was to construct a model of DNA (Appendix J). Students colored and cut out the pieces, then glued the pieces together in a particular order/pattern onto a paper towel roll. This model demonstrated how DNA resembled a twisted ladder. Students worked with a partner to understand the structure of DNA.

On Day 3, students completed a quiz where they had to match vocabulary terms with the correct definitions, and could use their vocabulary flashcards. Next, students completed the same lab as the inquiry-based group, in which DNA was extracted from a

strawberry (Appendix D). Once the lab was completed, students were assigned to finish the DNA model from Day 2 and complete it for homework if necessary.

On Day 4, students completed a worksheet in which they colored the different components that make up the structure of DNA (<http://biologycorner.com/worksheets/DNAcoloring.html>). This worksheet was meant to reinforce their understanding of how DNA is put together. They worked in pairs and could use the textbook for guidance.

On Day 5, students viewed a short PowerPoint on DNA replication (Appendix K) and filled in guided notes (Appendix L). Students then completed a worksheet practicing DNA replication and were able to ask questions for clarification (Appendix E). This worksheet was the same one as used by the inquiry group. A second short PowerPoint was viewed on RNA (Appendix M) and students filled in guided notes (Appendix N). Students were then allowed time to finish the DNA model from Days 2 and 3.

On Day 6, students viewed a PowerPoint on Transcription and Translation (Appendix O) and filled in guided notes (Appendix P). A worksheet (http://www.biologycorner.com/worksheets/DNA_snorks.html) was completed (partially as a class for demonstration, and partially as individual practice) to practice how DNA translates to RNA and then transcribes to an amino acid. At the end of the guided practice worksheet, a game was played to practice the same processes. Codon bingo is a game where the bingo squares consist of names of amino acids (http://www.accessexcellence.org/AE/AEPC/WWC/1994/codon_bingo.php). Students are told the 3-letter DNA sequence that they then have to translate to RNA and

transcribe to the correct amino acid to be able to cross out the square on their bingo card. Students were also given a study guide for the test to complete individually as homework. On Day 7, students were administered the posttest, followed by the unit DNA test.

There were several main differences between the way the experimental inquiry group and the control traditional group were taught (Table 2). The first main difference was that the control group was often shown PowerPoints and filled in guided notes as I lectured, while the experimental group had no PowerPoints, lectures, or guided notes of any kind. Another difference between the two groups was the type of DNA model created. The experimental group was given the pieces of the DNA components and then had to collaboratively conclude “how” to put them together, whereas the control group’s model involved students cutting, folding, and pasting according to my directions. No higher order thinking was needed for the assignment because it was fully guided activity.

A third difference was in the teaching of translation and transcription. The experimental group first “translated” messages by using Morse code then related this concept of coding in the process of protein synthesis. The control group had no such relationship demonstrated, and the only example given was in the lecture and notes. The control group was given practice worksheets and provided assistance from myself or their peers to understand this same concept.

The final difference between the two groups was that when given the study guide for the unit test, the inquiry groups worked on it in class and were given assistance as

needed, while the traditional group worked on it individually out of class. These students were still allowed to receive assistance through email or after school.

Table 2: Differences in activities for each group

Traditional Group	Inquiry Group
<ul style="list-style-type: none">• PowerPoint, guided notes, teacher lecture	<ul style="list-style-type: none">• Did not view a PowerPoint, fill in any guided notes, no lectures
<ul style="list-style-type: none">• Teacher-led DNA model	<ul style="list-style-type: none">• Student-led DNA model
<ul style="list-style-type: none">• Examples for DNA coding from guided notes/lecture	<ul style="list-style-type: none">• Morse code activity, DNA coding worksheet
<ul style="list-style-type: none">• Study guides for homework	<ul style="list-style-type: none">• Study guides were completed in class together; teacher led

DATA AND ANALYSIS

After completing the DNA unit with both groups, the data from the pretest and posttest was analyzed. Some student scores were excluded because they did not complete either the pretest or posttest, or neither, due to absences. All t-tests run in this study were at a 95% confidence level, unless otherwise stated. There was no significant difference in pretest scores for both groups of students, indicating all students were homogenous in their prior knowledge of DNA and its structure (Table 3). After teaching both groups in their respective formats, another t-test indicated there is likely a significant difference between the traditionally instructed students and the inquiry students (Table 3). Based on the results shown in Figure 1, it appears that inquiry-based teaching produces higher posttest scores than the traditional teaching method.

Table 3: Pretest and Posttest Average Scores

Class Type	Pretest Mean Raw Scores	Posttest Mean Raw Scores
Inquiry (n=69)	35.8% ± 1.8%	43.0% ± 1.9%
Traditional (n=57)	33.9% ± 1.8%	35.1% ± 2.1%
T-test Results	p > 0.05	p < 0.05

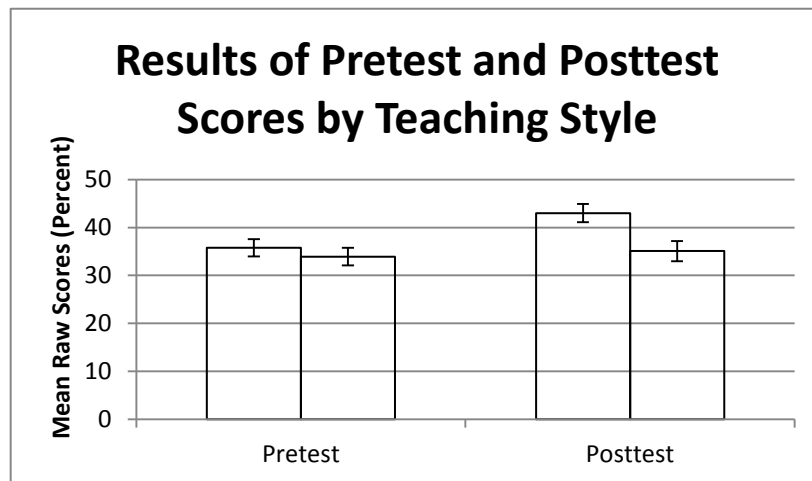

Figure 1: Pretest and Posttest Average Scores: The diagonal hatching represents the inquiry group, while the checkered hatching represents the traditional group

However, these results also brought up several other questions.

- Was there a significant difference between the honors class and the academic classes who were both taught through inquiry?
- Does gender make a difference in learning gains, if inquiry males were compared to traditional males, and the same for the females in each group?
- Would the inquiry groups perform better on the unit test and/or the final course grades?

An individual analysis of these questions can provide further insight from the data.

DOES IT MAKE A DIFFERENCE WHETHER STUDENTS WERE IN AN HONORS CLASS RATHER THAN AN ACADEMIC CLASS?

The inquiry group was split into two subgroups – honors inquiry (n=26) and academic inquiry (n=43). The traditional group stayed the same. There was no significant difference in the pretest scores ($p = 0.66$) as a result of an ANOVA test, but

there was a significant difference in the posttest scores ($p = 0.012$), as shown in Figure 2. Therefore, students started with the same prior knowledge, no matter which group they were in, but it is not specified through this test which of the three groups improved. To try and determine which group(s) improved, the learning gains were compared using ANOVA. The results showed no significant difference ($p = 0.23$) when comparing the three groups. To compare each group to each other, t-tests were conducted. A comparison of the honors inquiry group and the academic traditional group showed a significant difference ($p = 0.004$), indicating that the honors group improved with the inquiry-based teaching style over the academic group of traditionally taught students. A comparison of the academic inquiry group to the academic traditional group showed no significant difference between the two groups ($p = 0.104$), indicating that for the academic students, teaching style did not make a difference.

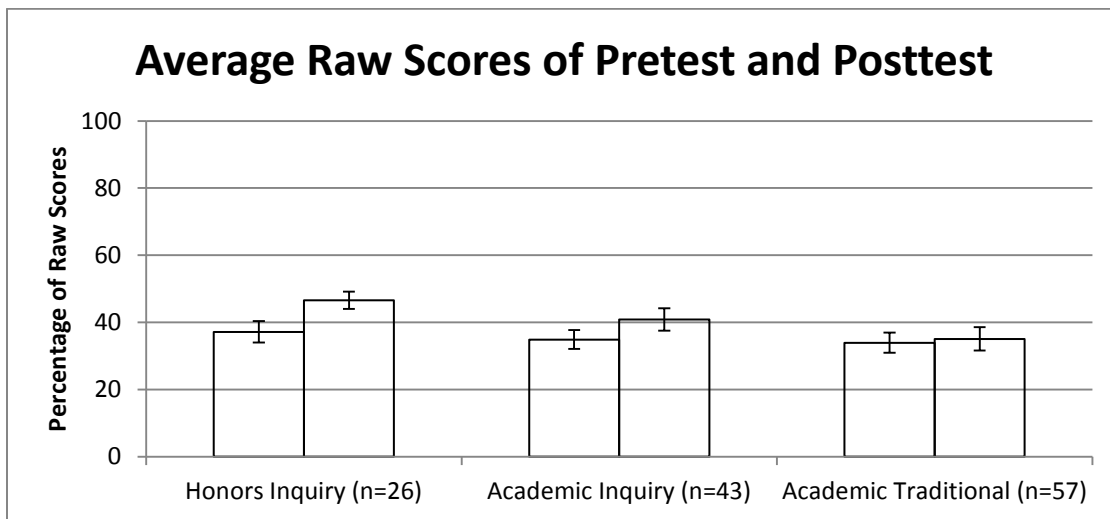

Figure 2: Average Raw Scores of Pretest and Posttest for Inquiry and Traditional Groups: The diagonal hatching represents the Pretest scores, while the checkered hatching represents the Posttest scores

When comparing the raw learning gains for all three groups, all three appeared to have some growth from pretest to posttest. However, the only significant difference was between the honors inquiry group and the academic traditional group, as seen in Figure 3. The trend between the three groups suggests that not only do teaching styles need to be compared, but the fact of whether they are honors students or academic students can also play into the results.

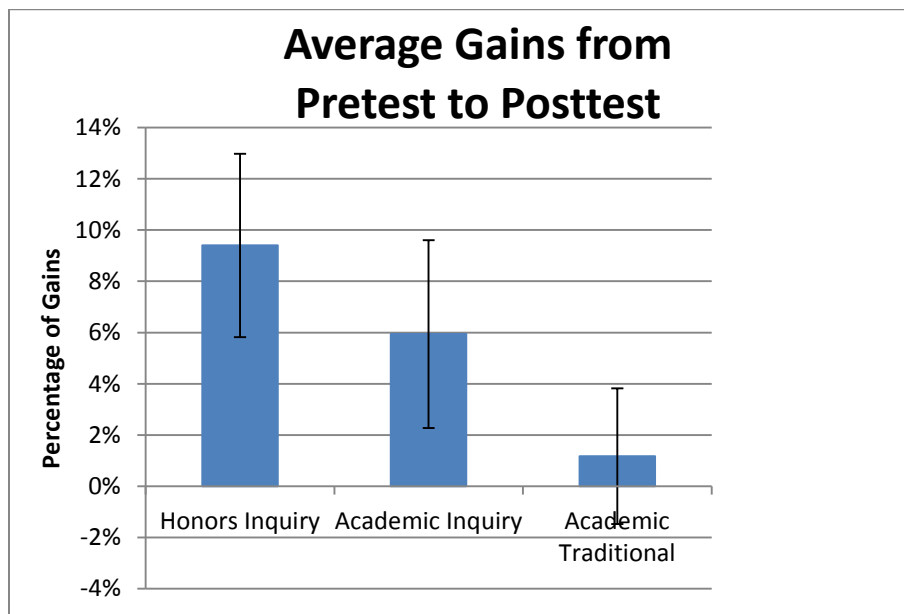

Figure 3: Average Raw Gains from Pretest to Posttest for Inquiry and Traditional Groups

DOES GENDER MAKE A DIFFERENCE WHEN COMPARING INSTRUCTIONAL FORMAT?

When comparing males to females, a t-test was first used to compare the pretest scores of all females to the pretest scores of all males. The results showed there was likely no significant difference between males and females regarding prior knowledge before the different teaching styles were used ($p < 0.05$). ANOVA was then used to

compare the females posttest scores and then again for the males posttest scores. A Bonferroni correction was used to reduce the critical p-value to 0.017, since multiple comparisons were taking place. Between the females, ANOVA results showed there was no statistical difference in the posttest scores ($p = 0.28$), but the males showed there was a significant difference between the three groups ($p = 0.02$), T-tests were run for the males to find where that difference was. Results showed the difference was between the honors inquiry and traditional groups ($p = 0.013$), as seen in Figure 4.

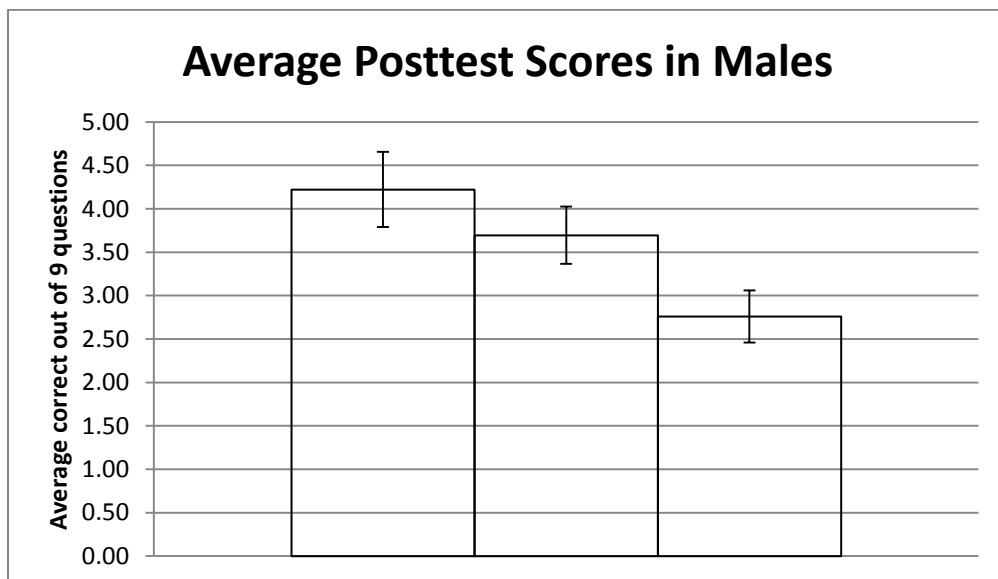

Figure 4: Average Posttest Scores of Males: Honors inquiry (n=9) is represented by diagonal stripe hatching, Academic inquiry (n=23) is represented by checkered hatching, and Academic traditional (n=25) is represented by dotted hatching

Next, the average learning gains for each gender were compared after completing the unit with all classes. There was not a significant difference when comparing the gains in females ($p = 0.96$) according to ANOVA, but there was a significant difference when comparing the gains of the males ($p = 0.03$). T-tests were then run to compare each group of males to each other, using a Bonferroni correction

test. Results showed only a significant difference honors inquiry and academic traditional, as seen in Figure 5. From this information, I can deduce that while females can learn the same material either traditionally or through inquiry, males can excel more when using the inquiry based learning rather than the traditional style of learning, particularly in an honors class. In fact, the only overall gains that appeared were due to the male population. The females remained similar.

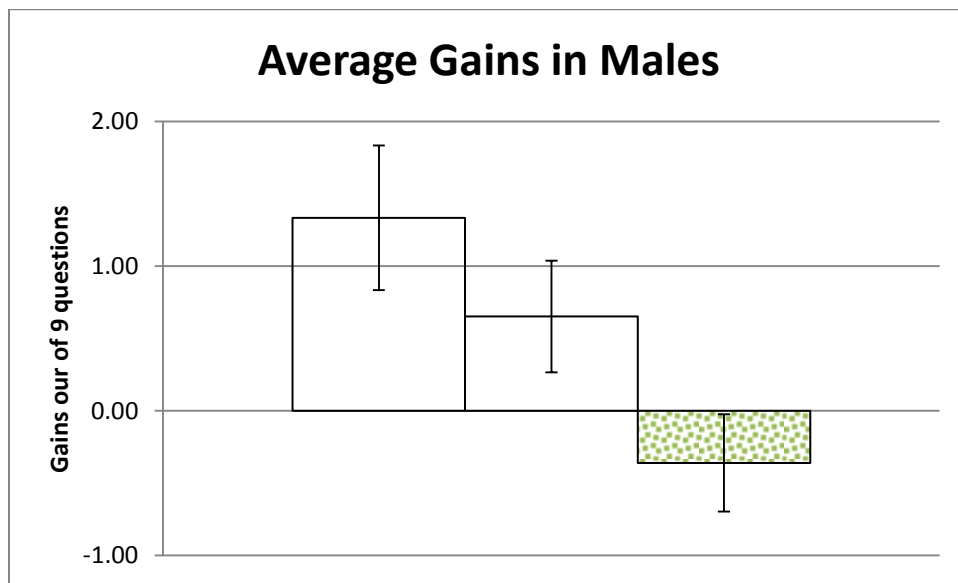

Figure 5: Average Raw Gains in Males: Honors inquiry (n=9) is represented by diagonal stripe hatching, Academic inquiry (n=23) is represented by checkered hatching, and Academic traditional (n=25) is represented by dotted hatching

DOES INSTRUCTIONAL FORMAT MAKE A DIFFERENCE IN UNIT TEST SCORES AND/OR IN FINAL COURSE GRADES?

According to my results in this study, only the honors students seemed to benefit from doing inquiry-based activities. However, it raised another question: did having inquiry-based activities improve scores on the DNA unit test for only honors inquiry students or did it also improve the academic scores? An ANOVA test concluded there

was a significant difference between the three groups – honors inquiry, academic inquiry, and academic traditional. A Bonferroni correction was used to reduce the critical p-value to 0.017, since multiple comparisons were taking place. A significant difference was found between the honors inquiry students and the academic traditional students ($p < 0.001$) using a t-test, and also between the academic inquiry students to the academic traditional students ($p = 0.01$). This data implies that the inquiry students performed better on the DNA unit test than did the traditional students, as seen in Figures 6 and 7. There was no significant difference between the two inquiry groups ($p = 0.04$), meaning that these two groups were similar.

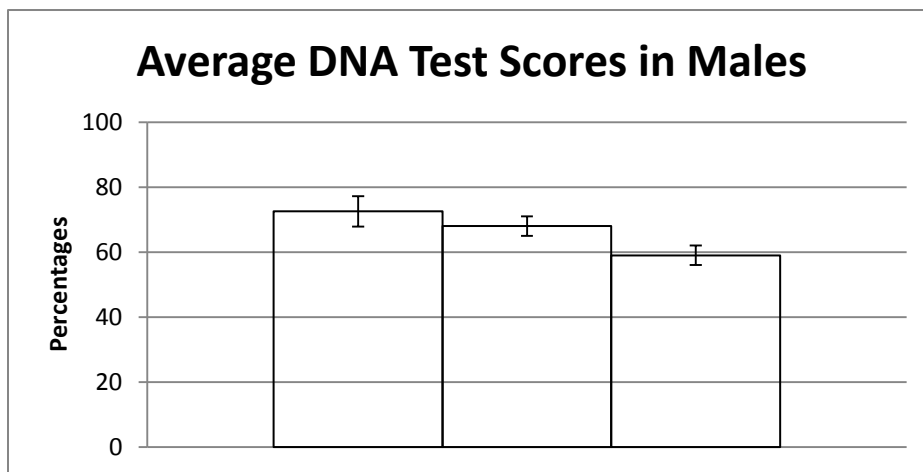

Figure 6: Average Unit Test Scores in Males by Teaching Style: Honors inquiry is represented by diagonal stripe hatching, Academic inquiry is represented by checkered hatching, and Academic traditional is represented by dotted hatching

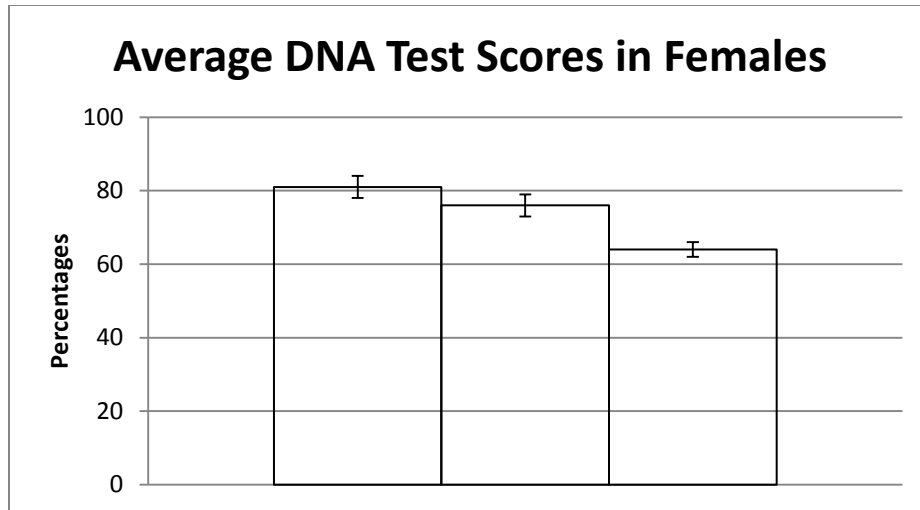

Figure 7: Average Test Scores for Unit Test in Females by Teaching Style: Honors inquiry is represented by diagonal stripe hatching, Academic inquiry is represented by checkered hatching, and Academic traditional is represented by dotted hatching

In a small way, this similarity was expected based on my Biology class grades. I wanted to see if the experiment had an effect on student's grades. I compared Quarter 2 grades, which included the DNA test scores (Figures 6 and 7); to the final course grades, which are cumulative of Quarters 1 – 4. Quarter 1 grades were used as a basis of comparison in order to see if there really was an improvement. It should be noted that grades for all students who participated in the study were not available due to students moving to other schools. The number of honors males stayed the same, but the academic inquiry males' number dropped by 3, and the traditional group dropped by 5. The number of students reviewed is noted in the graphs.

Using an ANOVA test, no significant difference was found for the females in either Quarter 1 grades, Quarter 2 grades, or the final course grades when comparing all three subgroups. However, ANOVA showed all male subgroups had significant differences for Quarter 1, Quarter 2, and final course grades. Using a Bonferroni

correction test ($p = 0.017$), significant differences were found in the Quarter 1 grades only between the two inquiry groups ($p = 0.003$) and between the honors inquiry and the traditional students ($p = 0.003$). In the Quarter 2 grades, only a significant difference was found between the honors inquiry and the traditional groups ($p = 0.004$). When comparing the final course grades for the males, a small significant difference was found between the honors and academic inquiry students ($p = 0.01$). Another significant difference was found between the honors inquiry and the traditional groups ($p = 0.001$). These differences can be seen in Table 4 and Figure 8. There is a difference in male scores for the inquiry groups, but it seems to come solely from different scores between the honors inquiry group and the traditional academic group. This is to be expected because honors students generally score higher overall.

Table 4: Comparison of Quarter grades before experiment (Quarter 1) and after experiment (Quarter 2 and final course grades) for Males

	Honors Inquiry Males (n=9)	Academic Inquiry Males (n=20)	Traditional Males (n=20)
Quarter 1 Grade	78% ± 2%	67% ± 2%	67% ± 2%
Quarter 2 Grade	82% ± 3%	75% ± 2%	70% ± 3%
Final Grade	80% ± 2%	71% ± 2%	67% ± 3%

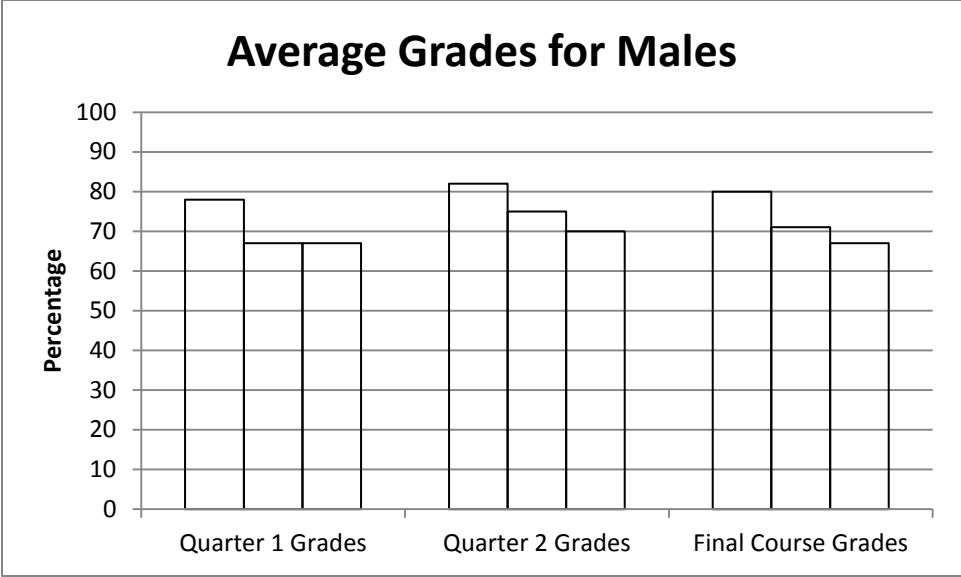

Figure 8: Average Grades for Males: Honors inquiry (n=9) is represented by diagonal stripe hatching, Academic inquiry (n=23) is represented by checkered hatching and Academic traditional (n=25) is represented by dotted hatching

CONCLUSIONS

Based on my results, it appears that inquiry-based activities make a difference in learning gains for honors students, and to some degree for academic students. All students began with the same level of knowledge, but only the honors students appeared to benefit statistically by the inquiry-based activities. When comparing just the academic students, inquiry-based learning did not seem to make a difference over the traditional learning style in this study. However, when looking at unit test scores, the inquiry students scored significantly higher than the traditional students. This difference leads me to believe that inquiry-based learning does work and that my modified Genetics Concept Inventory consisting of 9 questions was likely not a good assessment tool with so few questions.

After completing both teaching styles, I noted some qualitative differences between the groups. My initial personal impression was that the inquiry group was more engaged; the students were interested in the idea as soon as I told them they wouldn't be taking notes. Both groups reviewed material daily, but when references were made to previous material such as the DNA model, it seemed to me that the inquiry group was quicker to recall information and could remember details that the traditional group could not. There also appeared to be a better rapport with my inquiry-based group than my traditional group. Usually when taking notes, students tend to "tune out" the information being taught and just fill in the blanks on the guided notes, rather than actually process the new information. With the inquiry group, I observed they were more engaged and had more interpersonal interaction because they had to participate in the discussions and actively review in order to grasp the new information.

Engagement of students is just one factor that could produce these differences in student learning, in addition to the teaching style. Perhaps if we can get students engaged in any activity, notes included, they will learn more despite the teaching format. It's difficult to conclude if my students performed better because they were more engaged or if it was because of the inquiry activities themselves, but my data still shows a significant difference between the two groups based on the posttest results.

If I could do this study again, I would like to use more inquiry activities throughout the year, rather than one topic, so students could become more familiar with the method. With this study, I'm not sure the students understood exactly what they were supposed to be doing in inquiry. I am going to use two of the inquiry activities used in this study because I think it is a better way of teaching the concept. In addition, I have begun thinking of lab activities that we use already in our curriculum, but could become inquiry based by doing them as a discovery activity prior to the lecture. I would also change my assessment tool to include more questions to obtain more data so that my results could be more accurate. With only nine questions, a change from one answer on the pretest to a different answer on the posttest could considerably change my results.

I felt some students did not give me their "best effort" on the pretest and posttest, so I could offer more incentives or rewards for them to motivate them. Also, I could use the posttest and other activities as "real" grades, not just participation points. Finally, I would like to see something similar to this study completed in upperclassmen to eliminate the immaturity factor of ninth grade students. As ninth grade students, there are already so many things changing, socially and emotionally, as they transition from middle school to high school that some students tend to lose focus on their academics.

Although there were many factors that could have been different throughout this study, overall, the positive results gained from the students in the experimental group shows that inquiry-based activities help to increase student engagement and achievement.

REFERENCES

- Elrod, S. 2008. Genetics concept inventory (GenCI) development. 2008. Paper presented at Conceptual Assessment in Biology Conference II; 3–8 January, Asilomar, California. (25 September 2008; <http://bioliteracy.net/CABS.html>)
- Hake, R.R. 1998. Interactive-engagement versus traditional methods: A six-thousand-student survey of mechanics test data for introductory physics courses. *American Journal of Physics*, 66(1), 64-74.
- Halloun, I., Hestenes, D. 1985. The initial knowledge state of college physics students. *American Journal of Physics* 53: 1043–1055.
- Hestenes, D., Wells, M., Swackhamer, G. 1992. Force Concept Inventory. *Physics Teacher* 30: 141–158
- Savinainen, A., and Scott, P. 2002, The Force Concept Inventory: a tool for monitoring student learning, *Phys Educ* 37(1): 45-52.
- Smith MK, Wood WB, Knight JK. 2008. The genetics concept assessment: A new concept inventory for gauging student understanding of genetics. *CBE Life Sci Edu* 7, 422-430. Additional future tests to be posted online at www.colorado.edu/sei/departments/mcdb_assessment.htm
- Timmerman, B.E., Strickland, D.C. & Carstensen, S.M. 2008. Curricular reform and inquiry teaching in biology: where are our efforts most fruitfully invested? *Integrative and Comparative Biology*, 48, 226–240.
- Wilden, J., Crowther, D., Gubanich, A., Cannon, J. 2002. A Quantitative Comparison of Instruction Format of Undergraduate Introductory Level Content Biology Courses: Traditional Lecture Approach vs. Inquiry Based for Education Majors. Paper presented at the Annual International Conference of the Association for the Education of Teachers in Science, Charlotte, North Carolina, Jan 10-13

APPENDIX A: OUTLINE OF PROCEDURE

Experimental Group - Inquiry

Day 1

- Pre-test
- Bell Work – Define terms
- DNA Model Activity

Day 2

- Put DNA Model together
- Complete DNA worksheet

Day 3

- Berry Full of DNA Extraction Lab
- DNA Replication Worksheet

Day 4

I was absent. Students completed textbook based worksheet assignment that was not inquiry based.

Day 5

- Define terms
- Secret Codes Activity

Day 6

- Worksheet – Follow-up to Translation/Protein Synthesis
- Complete Study guide for Test as a class

Day 7

- Post-Test
- DNA Test

Control Group - Traditional

Day 1

- Pre-test
- DNA Unit Vocabulary
- Notes - DNA
- DNA Structure Worksheet
- HOMEWORK – Finish Vocabulary and Worksheet

Day 2

- Collect DNA worksheet (HW grade)
- Check Vocabulary (HW grade)
- Begin DNA model

Day 3

- Open Note Vocabulary Quiz
- Berry Full of DNA Lab
- Finish DNA model

Day 4

I was absent. Students completed DNA coloring activity

Day 5

- Notes – DNA Replication
- DNA Replication Worksheet
- Notes – RNA
- Finish DNA model/Finish DNA Coloring from Thursday

Day 6

- Notes – Transcription/Translation
- Snorks Worksheet
- Codon Bingo
- Given study guide for test

Day 7

- Post-Test
- DNA Test

APPENDIX B: PRETEST/POSTTEST

Name _____ Block _____

- 1) _____ In eukaryotic cells, where does transcription occur?
 - a) ribosomes
 - b) cytoplasm
 - c) nucleus
 - d) vacuole

- 2) _____ Which of the following molecules are the products of transcription?
 - a) DNA
 - b) amino acids
 - c) messenger RNAs
 - d) proteins
 - e) cells
 - f) chromosomes

- 3) _____ Which of the following molecules are the products of translation?
 - a) DNA
 - b) amino acids
 - c) messenger RNAs
 - d) proteins
 - e) cells
 - f) chromosomes

- 4) _____ In which of the following cell types within your body are genes found?
 - a) brain
 - b) blood
 - c) eye
 - d) heart
 - e) reproductive (gametes, etc.)
 - f) all of these

- 5) _____ What are most genes made of?
- a) protein
 - b) RNA
 - c) DNA
 - d) chromosomes
 - e) alleles
 - f) cells
- 6) _____ Where can DNA be found within animal cells?
- a) nucleus
 - b) Ribosomes
 - c) Mitochondria
 - d) both nucleus and mitochondria
 - e) both nucleus and ribosomes
- 7) _____ After DNA replication of a DNA double helix molecule, two DNA double helices result. Which of the following statements best describes the composition of the two remaining double helices?
- a) Both strands in one of the two helices are new and both strands in the other helix are old
 - b) In each of the two helices, one of the two strands is new
 - c) Random pieces along each strand of both helices are newly synthesized
- 8) _____ During DNA replication, what serves as the template for synthesis of a new strand?
- a) one of the two strands of the double helix
 - b) each of the two strands of the double helix
 - c) Random pieces of both strands of the double helix
- 9) _____ What is the chemical composition of DNA?
- a) protein
 - b) nucleotides
 - c) genes
 - d) traits

Answer Key

- 1) _____ In eukaryotic cells, where does transcription occur?
 - a) ribosomes
 - b) cytoplasm
 - c) nucleus**
 - d) vacuole

- 2) _____ Which of the following molecules are the products of transcription?
 - a) DNA
 - b) amino acids
 - c) messenger RNAs**
 - d) proteins
 - e) cells
 - f) chromosomes

- 3) _____ Which of the following molecules are the products of translation?
 - a) DNA
 - b) amino acids
 - c) messenger RNAs
 - d) proteins**
 - e) cells
 - f) chromosomes

- 4) _____ In which of the following cell types within your body are genes found?
 - a) brain
 - b) blood
 - c) eye
 - d) heart
 - e) reproductive (gametes, etc.)
 - f) all of these**

- 5) _____ What are most genes made of?
 - a) protein
 - b) RNA
 - c) DNA**
 - d) chromosomes
 - e) alleles
 - f) cells

- 6) _____ Where can DNA be found within animal cells?
- a) nucleus
 - b) ribosomes
 - c) mitochondria
 - d) both nucleus and mitochondria**
 - e) both nucleus and ribosomes
- 7) _____ After DNA replication of a DNA double helix molecule, two DNA double helices result. Which of the following statements best describes the composition of the two remaining double helices?
- a) Both strands in one of the two helices are new and both strands in the other helix are old
 - b) In each of the two helices, one of the two strands is new**
 - c) Random pieces along each strand of both helices are newly synthesized
- 8) _____ During DNA replication, what serves as the template for synthesis of a new strand?
- a) one of the two strands of the double helix
 - b) each of the two strands of the double helix**
 - c) Random pieces of both strands of the double helix
- 9) _____ What is the chemical composition of DNA?
- a) protein
 - b) nucleotides**
 - c) genes
 - d) traits

APPENDIX C: VOCABULARY TERMS

Inquiry Group

Day 1 Vocabulary

DNA
Deoxyribose
Phosphate
Nucleic acid
Adenine
Thymine
Cytosine
Guanine
Base pairs
Nucleotide

Day 5 Vocabulary

DNA
Messenger RNA
Ribosome
Amino acids
Protein
Codon
Morse code
Genetic code
Transcription
Translation

Traditional Group

Day 1 DNA Vocabulary

DNA
Purine
Pyrimidine
Messenger RNA
RNA
Ribosomal RNA
Transfer RNA
Transcription
Anticodon
Codon
Translation
Protein Synthesis
Base-pairing rule
Replication
DNA polymerase
RNA polymerase

APPENDIX D: DNA STRAWBERRY EXTRACTION LAB

(Standard used in Biology Department)

LAB ACTIVITY: BERRY FULL OF DNA

MATERIALS (per group):

Ziploc bag	Ice cold ethanol
3 strawberries	Clear plastic container
DNA extraction liquid	Toothpick
Meat tenderizer	Cheesecloth

PROCEDURE:

1. Put the strawberries into the Ziploc bag and smash for about two minutes. You need to completely crush the strawberries. You do not want this mixture to be really bubbly. The less bubbles the better.
2. When you are finished smashing, put 30 mL of the DNA extraction liquid (soapy, salt water) and $\frac{1}{2}$ teaspoon of meat tenderizer into the bag.
3. Smash for another minute. Be careful not to make too many soap bubbles.
4. Place the cheesecloth over the clear container and filter the solution. You need to collect around $\frac{2}{3}$ of the container.
5. Add 5 mL on ethanol into the container.
6. Watch for the development of several large air bubbles that have a white cloudy substance attached to them. This cloudy substance is DNA!
7. Take the toothpick and spin and twist it like you're making cotton candy. Try to tilt the container. You may get more DNA.
8. Pull out the DNA. It will look like mucus or egg white. As it dries, it will look like a spider web. These fibers are millions of DNA strands.

Name _____ Date _____ Block _____

CONCLUSION QUESTIONS: (3 points each) – *Restate the question!*

1. What did the DNA look like?
2. A person cannot see a single cotton thread 100 feet away, but if you would thousands of threads together into a rope, it would be visible. How does this statement relate to our DNA extraction?
3. In order to study our genes, scientists must extract the DNA from human tissue. Would you expect the method of DNA extraction we used for the strawberry to be the same for human DNA? Why or why not?
4. Is DNA the same in any cell in the human body? Defend your answer.
5. Do you think human DNA will look the same as strawberry DNA? Explain.
6. Describe two practical applications for being able to extract DNA from cells.

APPENDIX E: DNA REPLICATION WORKSHEET
(Standard used in Biology Department)

Name: _____

Replicate the following strands of DNA. Be sure to label the **5' and 3' ends** and the **template** and **complementary** strands.

DNA strand #1:

5' A – T 3'
A – T
C – G
T – A
G – C
3' G – C 5'

DNA strand #2:

5' C – G 3'
G – C
T – A
A – T
G – C
C – G
G – C
3' G – C 5'

DNA strand #3:

5' T – A 3'
T – A
A – T
G – C
C – G
3' T – A 5'

APPENDIX F: DNA UNIT TEST STUDY GUIDE

(Standard used in Biology Department)

Study Guide – Nucleic Acids and Protein Synthesis

1. What does DNA stand for?
2. What is the purpose of DNA?
3. What type of bonds hold the nitrogen bases of DNA together?
4. What type of bonds hold amino acids together?
5. The strands of DNA are made up of repeating ____.
6. A nucleotide consists of ____, ____, & ____.
7. What are the four nitrogen bases found in DNA?
8. What are the four nitrogen bases found in RNA?
9. What is the difference between purines and pyrimidines? Give examples of each.
10. In which order do the nitrogen bases bind to each other? And what kind of bond is it?
11. The DNA molecule is often called the ____.
12. Who discovered the structure of DNA?
13. What is the function of helicase in replication?
14. What is the end result of replication?
15. What does RNA stand for and what is its function? (What are the four bases?)
16. Name three ways that RNA's structure is different from DNA.
17. What enzymes break Hydrogen bonds and lay down free RNA nucleotides during transcription?
18. What is the end result of transcription?
19. Describe translation: (codon, anticodon, where does it take place, how many amino acids, genes, end result, how does the amino acids join together.)
20. Label the following on a DNA molecule: base pair, nucleotide, Deoxyribose, nitrogen base.
21. Use codon chart: Given RNA sequence what is amino acid sequence? (GUAUUUCCCUGA) What sequence of RNA will give valine, alanine, stop. Given DNA sequence, what is amino acid sequence? (CCTAAGGGT)
22. Where does DNA replication take place?
23. What are 3 reasons your body undergoes the DNA replication process?

APPENDIX G: DNA UNIT TEST
(Standard used in Biology Department)

Name _____ Date _____ Block _____

Biology Test

Test #5 - Nucleic Acids and Protein Synthesis

- 1) _____ The double strands of DNA are held together at the nitrogen bases by
 - a) glue
 - b) nitrogen bonds
 - c) hydrogen bonds
 - d) helix

- 2) _____ What chemical units make up a nucleotide?
 - a) thymine, guanine, uracil, phosphates
 - b) phosphates, nitrogen bonds, bases
 - c) 5-carbon sugar, phosphates, nitrogen bases
 - d) ribose, phosphates, bases

- 3) _____ Each set of three nitrogen bases representing an amino acid is referred to as a(n)
 - a) anticodon
 - b) Morse code
 - c) nucleotide
 - d) codon

- 4) _____ During the process of transcription, DNA serves as the template for making _____ which leaves the nucleus with the message from DNA.
 - a) tRNA
 - b) rRNA
 - c) mRNA
 - d) ribosome

- 5) _____ The process of converting RNA code into an amino acid sequence is called _____.
 - a) replication
 - b) transcription
 - c) translation
 - d) mutation

- 6) _____ The scientists that developed the double helix model of DNA were _____.
 - a) Lewis and Clark
 - b) Orville and Wilbur Wright
 - c) Watson and Crick
 - d) Gregor Mendel

- 7) _____ Which of the following "unzips" the DNA molecule during replication?
 - a) helicase
 - b) polymerase
 - c) start codon
 - d) anticodon

- 8) _____ Adenine and _____ are the two purines found in DNA.
- | | |
|-------------|------------|
| a) thymine | b) uracil |
| c) cytosine | d) guanine |
- 9) _____ How many different amino acids are there?
- | | |
|-------|-------|
| a) 4 | b) 10 |
| c) 20 | d) 64 |
- 10) _____ The process by which DNA duplicates itself is called _____.
- | | |
|------------------|----------------|
| a) transcription | b) translation |
| c) replication | d) mutation |
- 11) _____ Proteins are made in the cytoplasm whereas DNA is found only in the _____.
- | | |
|-----------------|------------------|
| a) mitochondria | b) nucleus |
| c) smooth ER | d) cell membrane |
- 12) _____ The process of _____ is very similar to the process of DNA replication.
- | | |
|------------------|----------------|
| a) transcription | b) translation |
| c) replication | d) mutation |
- 13) _____ Which of the following is not a nitrogen base found in RNA?
- | | |
|-------------|------------|
| a) adenine | b) guanine |
| c) cytosine | d) thymine |
- 14) _____ in DNA, guanine always binds with _____.
- | | |
|------------|-------------|
| a) adenine | b) cytosine |
| c) thymine | d) uracil |
- 15) _____ In the double helix, the _____ and the _____ form the rail of the "ladder" and the _____ form the rungs of the "ladder".
- | |
|--|
| a) deoxyribose, phosphates, nitrogen bases |
| b) nitrogen bases, deoxyribose, phosphates |
| c) phosphates, nitrogen bases, deoxyribose |
| d) guanine, cytosine, uracil |
- 16) _____ Amino acids join together with _____.
- | | |
|-------------------|-------------------|
| a) hydrogen bonds | b) nitrogen bonds |
| c) peptide bonds | d) glue |

- 17) _____ Thymine and cytosine are _____.
- | | |
|---------------|----------------|
| a) purines | b) pyrimidines |
| c) phosphates | d) sugars |
- 18) _____ In DNA, adenine bonds with _____.
- | | |
|------------|-------------|
| a) guanine | b) cytosine |
| c) thymine | d) uracil |
- 19) _____ In RNA, adenine bonds with _____.
- | | |
|------------|-------------|
| a) guanine | b) cytosine |
| c) thymine | d) uracil |
- 20) _____ During translation, amino acids bond with the anticodon to form _____.
- | | |
|-----------|----------------|
| a) codons | b) nucleotides |
| c) genes | d) proteins |

Use the diagram to answer the following questions. Use the figure below for questions 21–24.
(1 pt. each)

21. Which letter demonstrates a base pair? _____
22. Which letter shows a nucleotide? _____
23. Which letter points to a deoxyribose? _____
24. Which letter labels a nitrogen base? _____

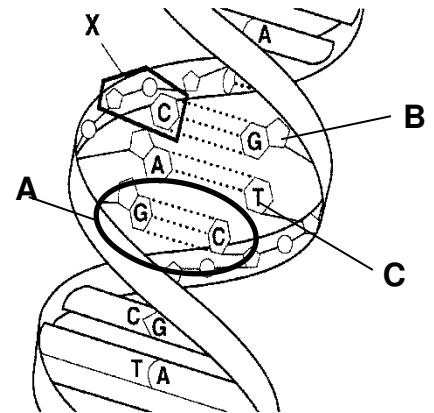

Use the codon chart for questions 25 – 27:
(2 pts. each)

- _____ 25. What would be the amino acid sequence for the following RNA sequence? **AUGGCUUUGUGA**
- A. start, threonine, glutamate, stop
 - B. valine, methionine, serine, glycine
 - C. methionine, alanine, leucine, stop
 - D. none of the answers

- _____ 26. Find the sequence of RNA that will give the following sequence of amino acids, proline, valine, leucine.

- A. **GGCGUAAUU**
- B. **CGGAAUGUC**
- C. **GGGAUGAAU**
- D. **CCCGUAUUA**

- _____ 27. Using this sequence of DNA, **TACGGGCAGATT**, find the sequence of amino acids.

- A. methionine, proline, valine, stop
- B. proline, valine, methionine, lysine
- C. theonine, threonine, asparagine, stop
- D. alanine, glutamate, glycine, serine

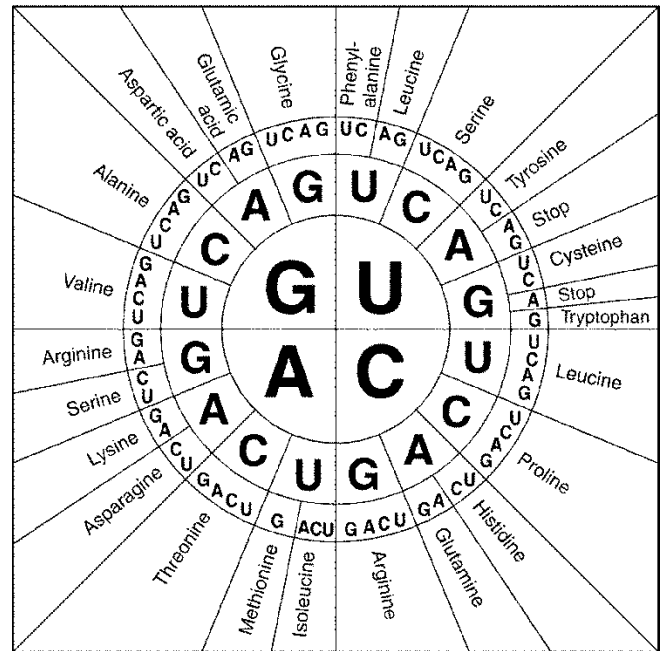

Constructed Response:

28. RNA and DNA are similar in structure yet different. Explain the three differences between them. (6 points)

DNA	RNA
•	•
•	•
•	•

29. DNA uses RNA to get the information to the ribosome so it can make the protein. Use the following DNA strand to transcribe to RNA, and then translate that to the amino acid. Use the codon chart on your test to create the amino acid sequence. (8 points)

DNA = TAC | AGA | TTG | TTT | GTC | CGA | ATT

mRNA = | | | | | |

amino acid sequence =

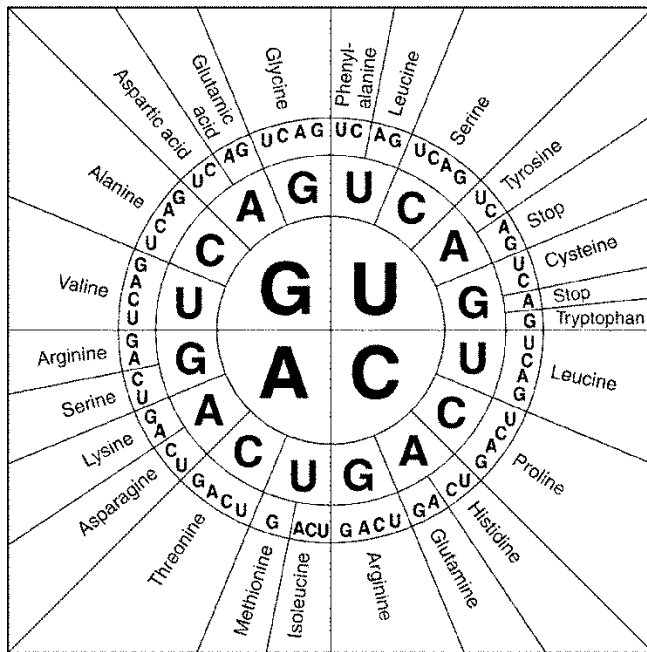

30. DNA replication is a vital process which occurs in the cells of the body. Every new cell that develops in your body needs an exact copy of the DNA from its parent cell. Using this information and what you learned in class, answer the following questions:

A) What is DNA replication? (2 points)

B) Where in the cell does DNA replication occur? (2 points)

C) What are three reasons your body undergoes DNA replication? (3 points)

D) Replicate the following DNA strand. Be sure to label your 5' and 3' ends and the complementary and template strands. (8 points)

5' C – G 3'
G – C
T – A
A – T
A – T
G – C
C – G
G – C
G – C
T – A
T – A
A – T
G – C
C – G
3' T – A 5'

APPENDIX H: TRADITIONAL GROUP DNA POWERPOINT (Standard used in Biology Department)



Stands for:
Deoxyribose
Nucleic Acid

1. DNA has 2 primary functions:

- Store and use information to direct activities of the cell
- To copy itself exactly for new cells that are created

2. Structure of DNA

- It is a polymer (composed of repeating subunits called monomers)
- The repeating units or monomers of DNA are nucleotides.
- DNA is composed of 2 long strands each of which is a chain of nucleotide monomers
- Each nucleotide has 3 parts: a 5 carbon sugar called deoxyribose, a phosphate group, and a nitrogen base

- The sugar molecule and phosphate groups are the same in every nucleotide but there are 4 nitrogen bases.

- Adenine (A)
- Guanine (G)
- Thymine (T)
- Cytosine (C)

3. The nitrogen bases

- Adenine and guanine are purines. They are composed of a double ring of carbon and nitrogen atoms

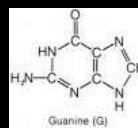
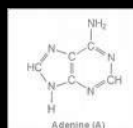

- Thymine and Cytosine are pyrimidines. They are composed of a single ring of carbon and nitrogen atoms.

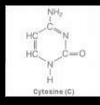
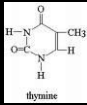

7

4. The Double Helix

- Each nucleotide bonds to another to form a long strand.
- The 2 strands bond together through hydrogen bonds that attach the nitrogen bases
- The nitrogen bases bond in a specific order
 - Adenine to thymine
 - Guanine to cytosine

8

- This forms a ladder with the deoxyribose and phosphate groups forming the rails of the ladder and the nitrogen bases forming the rungs of the ladder.
- Structure gets more complicated because it resembles a twisted ladder or DOUBLE HELIX structure
- Structure was discovered in 1953 by James Watson and Francis Crick. The most important discovery of the century.

9

APPENDIX I: TRADITIONAL GROUP DNA GUIDED NOTES

DNA (Stands for _____)

1. DNA has 2 primary _____:

- Store and use information to _____.
- _____ for new cells that are created

2. Structure of DNA

- It is a _____ (composed of repeating subunits called _____)
- The repeating units or monomers of DNA are _____.
- DNA is composed of _____ each of which is a chain of nucleotide monomers
- Each nucleotide has _____: a 5 carbon sugar called _____, a _____, and a _____.
- The sugar molecule and phosphate groups are _____ in every nucleotide but there _____.
 - _____ (A)
 - _____ (G)
 - _____ (T)
 - _____ (C)

3. The nitrogen bases

- Adenine and guanine are _____. They are composed of a _____ ring of carbon and nitrogen atoms
- Thymine and Cytosine are _____. They are composed of a _____ ring of carbon and nitrogen atoms.

4. The Double Helix

- Each nucleotide bonds to another to form a _____.
- The 2 strands bond together through _____ that attach the nitrogen bases.
- The nitrogen bases bond in a specific order
 - _____ to _____
 - _____ to _____
- This forms a ladder with the _____ forming the rails of the ladder and the _____ forming the rungs of the ladder.
- Structure gets more complicated because it resembles a twisted ladder or _____ structure

- Structure was discovered in 1953 by _____ and _____ . The most important discovery of the century.

APPENDIX J: TRADITIONAL GROUP – DNA MODEL

(Standard used in Biology Department)

DNA Model Instructions

IMPORTANT: If you do not follow directions, it will not look right. This counts as an activity/lab grade.

1. Work in partners. Get a paper towel tube and write both of your names at the very top edge.
2. Color all the **sugar** pieces the SAME color – check with your partner to be sure you do them the same. You may choose what color. Sugar is on each side of the Phosphate.
3. Color all the **phosphate** pieces the SAME color – check with your partner to be sure you do them the same. You may choose what color.
4. Color all the **A** pieces the SAME color – check with your partner to be sure you do them the same. You may choose what color. Color all the way to the zig-zag line. Your A piece will be longer than your T piece
5. Color all the **T** pieces the SAME color – check with your partner to be sure you do them the same. You may choose what color. Color all the way to the zig-zag line.
6. Color all the **G** pieces the SAME color – check with your partner to be sure you do them the same. You may choose what color. Color all the way to the zig-zag line. Your G piece will be longer than your C piece.
7. Color all the **C** pieces the SAME color – check with your partner to be sure you do them the same. You may choose what color. Color all the way to the zig-zag line.
8. Cut out everything, **INCLUDING THE CIRCLES AT THE END OF EACH A-T AND C-G PIECE. INCLUDE THE BLACK ARROWS!!!!**
9. Hole punch the circles in the Sugar/Phosphate piece.
10. Fold the A-T pieces and C-G pieces in half, hot dog style On the dotted line.
11. Glue an A-T piece to the top of the tube. Skip a little space and glue a C-G piece. The black arrow of the A-T piece should match up to the “C” line directly in the middle.
12. Continue until all A-T and C-G pieces are used. This forms the RUNGS of the ladder.
13. Then attach the hole punched Sugar/phosphate pieces. Thread the circle on each end into the hole punched area. These pieces make the RAILS of the ladder.
14. SEE MY EXAMPLE IF YOU NEED FURTHER CLARIFICATION!

(Model continues on next page)

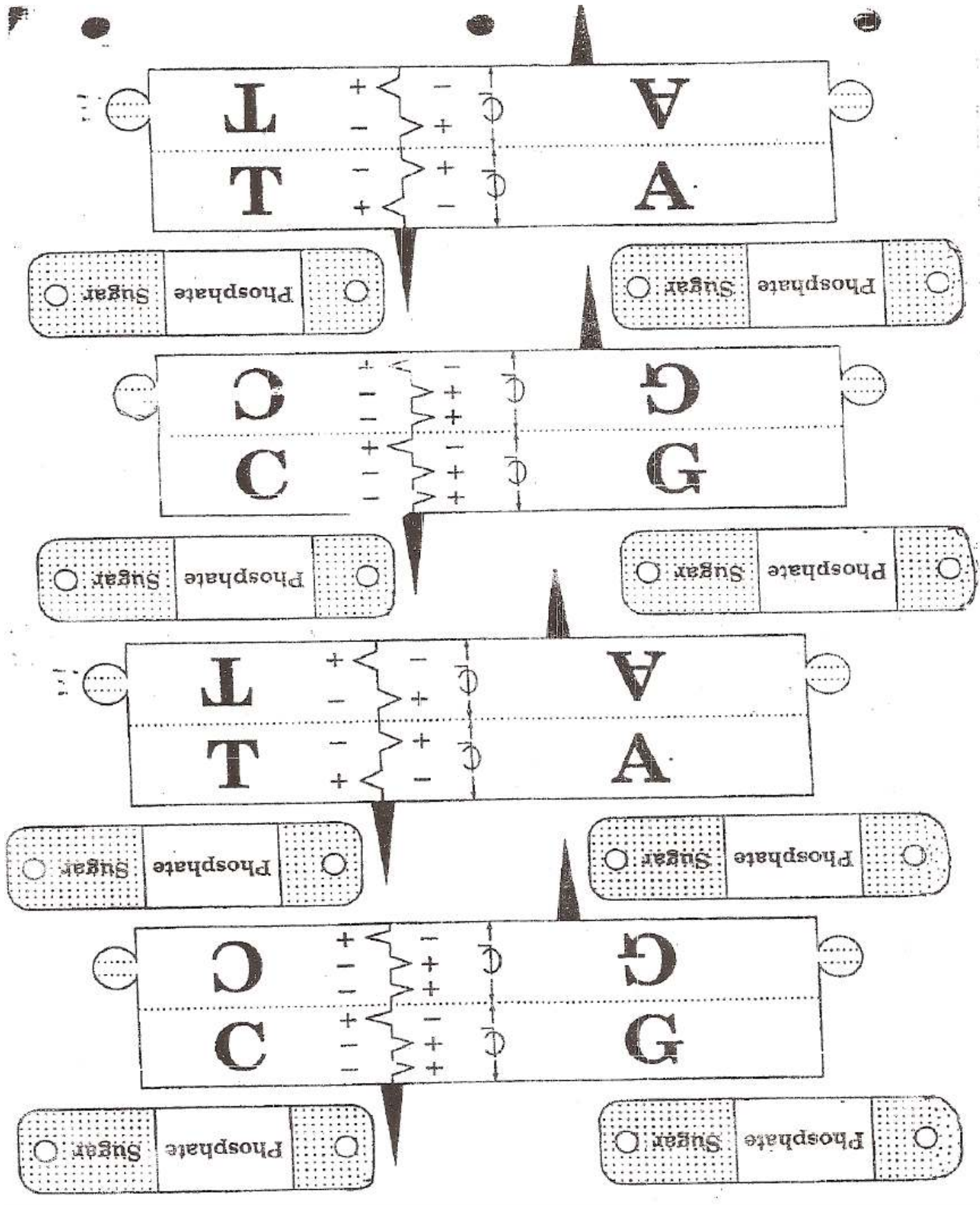

APPENDIX K: TRADITIONAL GROUP DNA REPLICATION NOTES POWERPOINT

(Standard used in Biology Department)

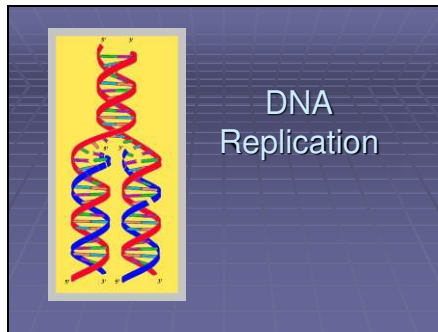

What is it?

- The process of copying DNA in a cell is called replication
- During replication, the 2 nucleotide chains separate by unwinding, and each chain serves as a template for a new nucleotide chain.

Where and Why?

- Occurs in the nucleus
- Three reasons your body undergoes replication are:
 - Growth
 - Repair
 - Reproduction

Steps of Replication:

- **Helicase** enzymes unwind the DNA's two chains of nucleotides
- DNA **polymerases** bind to the separated chains of nucleotides. One nucleotide at a time, the enzyme constructs a new complementary chain of nucleotides.
- At the end of replication, there are two **identical** copies of the original DNA molecule. Each DNA molecule is made of one chain of nucleotides from the **original** DNA molecule and one **new** chain of nucleotides.

Side Notes

- DNA always replicates from the **5'** end to the **3'** end. (" is pronounced "prime"). Just like you read a book from left to right, DNA replicates in one direction only.

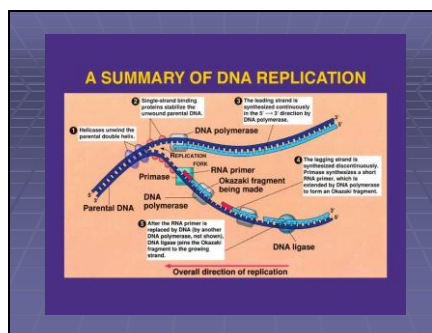

APPENDIX L: DNA REPLICATION GUIDED NOTES

DNA Replication

What is it?

- The process of _____ DNA in a cell is called _____.
- During replication, the 2 nucleotide chains _____ by unwinding, and each chain serves as a _____ for a new nucleotide chain.

Where and Why?

- Occurs in the _____
- Three reasons your body undergoes replication are: _____, _____, and _____.

Steps of Replication:

- _____ enzymes unwind the DNA's two chains of nucleotides
- DNA _____ bind to the separated chains of nucleotides. One nucleotide at a time, the enzyme constructs a new complementary chain of nucleotides.
- At the end of replication, there are two _____ copies of the original DNA molecule. Each DNA molecule is made of one chain of nucleotides from the _____ DNA molecule and one _____ chain of nucleotides.

** DNA always replicates from the _____ end to the _____ end. (' is read as "prime"). Just like you read a book from left to right, DNA replicates in one direction only.

APPENDIX M: TRADITIONAL GROUP RNA NOTES POWERPOINT

(Standard used in Biology Department)

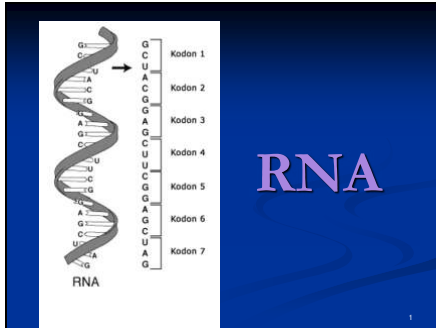

**Primary Function:
Protein Synthesis**

RNA vs. DNA

1. RNA only has one strand of nucleotide; DNA has 2 strands
2. RNA has ribose as its 5-carbon sugar; DNA has deoxyribose as its sugar
3. RNA has nitrogen base of uracil instead of thymine; DNA does not

3 types of RNA

1. Messenger RNA (mRNA)- single uncoiled chain

2. Transfer RNA (tRNA) "hairpin" shaped

Transfer RNA

Amino acid

Anticodon

3. Ribosomal RNA (rRNA)- most abundant type, globular shaped

Large Subunit

Small Subunit

Transcription (DNA to RNA)

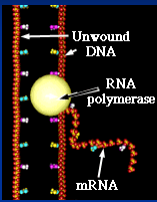

- RNA polymerase causes separation of DNA molecule
- Binds to a promoter region
- Only one strand used as a template
- RNA polymerase adds RNA nucleotides following base pair rule. (adenine-uracil)
- Continues until reach a termination signal

7

Following transcription- mRNA leaves the nucleus through pores to the cytosol to direct protein synthesis

8

APPENDIX N: TRADITIONAL GROUP RNA GUIDED NOTES

RNA

1. Primary Function: _____

2. RNA vs. DNA

- RNA only has _____ of nucleotide
- RNA has _____ as its 5-carbon sugar
- RNA has nitrogen base of _____ instead of thymine

3. Three types of RNA

- a. Messenger RNA (mRNA) - _____
- b. Transfer RNA (tRNA) - _____
- c. Ribosomal RNA (rRNA) - _____

4. Transcription (From DNA to RNA)

- _____ causes separation of DNA molecule
- Binds to a _____ region
- Only _____ used as a template
- RNA polymerase adds RNA nucleotides following base pair rule. (adenine-uracil)
- Continues until reach a _____ signal

5. Following transcription- mRNA leaves the nucleus through pores to the cytoplasm to direct protein synthesis

APPENDIX O: TRADITIONAL GROUP TRANSLATION AND TRANSCRIPTION POWERPOINT

(Standard used in Biology Department)

DNA Translation (mRNA to Proteins)



1

- Each set of 3 nitrogen bases representing an amino acid is called a codon [triplet code].
- The start codon is always AUG, Which codes for the amino acid - methionine



2

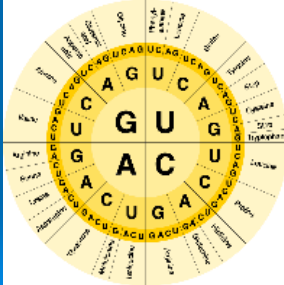

3

- More than one codon can code for the same amino acid, but there is only one amino acid per codon. Example:
 - AUU
 - AUC
 - AUA
 - All represent *Isoleucine*

4

Translation, Part 2

B. Ribosomal RNA The ribosome positions the start codon to attract its anticodon, which is part of the tRNA. The ribosome also binds the next codon and its anticodon and so on.

5

Translation, Part 3

C. Transfer RNA Each transfer RNA has an anticodon whose bases are complementary to a codon on the mRNA strand. Each tRNA also carries an amino acid.

6

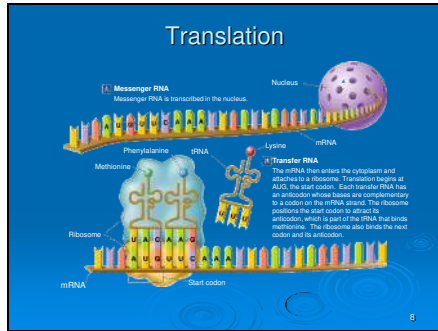

The Polypeptide “Assembly Line”

➤ The ribosome joins the two amino acids with a **peptide bond** - methionine and phenylalanine and breaks the bond between methionine and its tRNA. The tRNA floats away, allowing the **ribosome** to bind to another tRNA. The ribosome moves along the mRNA, binding new tRNA molecules and amino acids.

➤ The process continues until the ribosome reaches one of the three stop codons. The result is a growing polypeptide chain or a **PROTEIN**

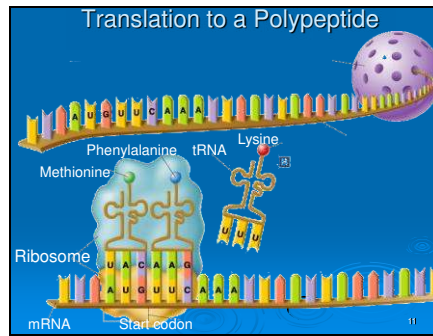

➤ The order of the nitrogen bases in DNA can determine the type and order of amino acids in a protein. Example:
DNA = TAC AGA TTG TTT GTC CGA ATT
mRNA = AUG UCU AAC AAA CAG GCU UAA

➤ Amino Acid Sequence:
 Methionine [start] - serine- asparagine - lysine - glutamine - alanine - stop

APPENDIX P: TRANSLATION GUIDED NOTES

Translation (_____)

Each set of 3 nitrogen bases representing an amino acid is called a _____ [triplet code].

The start codon is always _____, which codes for _____.

More than one codon can code for the same _____, but there is only one amino acid per codon.

Example: AUU, AUC, AUA

All represent _____

TRANSLATION PROCESS:

(From mRNA to Amino acid to protein)

- _____ is transcribed in the nucleus. The mRNA then enters the cytoplasm and attaches to a _____.
- _____: The ribosome positions the start codon to attract its _____, which is part of the tRNA. The ribosome also binds the next codon and its anticodon and so on.
- _____: Each transfer RNA has an _____ whose bases are complementary to a codon on the mRNA strand. Each tRNA also carries an _____.

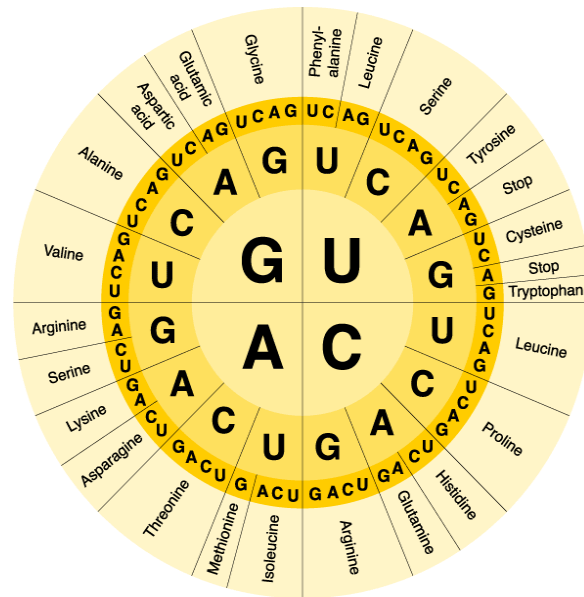

The Polypeptide (*Amino Acid*) “Assembly Line”

- The ribosome joins the two amino acids with a _____ — methionine and phenylalanine and breaks the bond between methionine and its tRNA. The tRNA floats away, allowing the ribosome to bind to another tRNA. The ribosome moves along the mRNA, binding new tRNA molecules and amino acids.
- The process continues until the ribosome reaches one of the three _____ codons. The result is a growing polypeptide (*amino acid*) chain or a _____

Translation to an Amino Acid (Polypeptide)

- The order of the nitrogen bases in _____ can determine the type and order of amino acids in a protein.
- Example:
 - DNA = TAC | AGA | TTG | TTT | GTC | CGA | ATT
 - mRNA = ____ | ____ | ____ | ____ | ____ | ____ | ____
 - amino acid sequence:

Codons

- How many codons are needed to specify ONE amino acids? _____
- Why is it possible for an amino acid to be specified by more than one kind of codon?

APPENDIX Q: IRB EXEMPTION DOCUMENTATION

Application for Exemption from Institutional Oversight



Institutional Review Board
Dr. Robert Mathews, Chair
131 David Boyd Hall
Baton Rouge, LA 70803
P: 225.578.8692
F: 225.578.6792
irb@lsu.edu
lsu.edu/irb

Unless qualified as meeting the specific criteria for exemption from Institutional Review Board (IRB) oversight, ALL LSU research/ projects using living humans as subjects, or samples, or data obtained from humans, directly or indirectly, with or without their consent, must be approved or exempted in advance by the LSU IRB. This Form helps the PI determine if a project may be exempted, and is used to request an exemption.

-- Applicant, Please fill out the application in its entirety and include the completed application as well as parts A-E, listed below, when submitting to the IRB. Once the application is completed, please submit two copies of the completed application to the IRB Office or to a member of the Human Subjects Screening Committee. Members of this committee can be found at <http://www.lsu.edu/screeningmembers.shtml>

- A Complete Application Includes All of the Following:

- (A) Two copies of this completed form and two copies of part B thru E.
- (B) A brief project description (adequate to evaluate risks to subjects and to explain your responses to Parts 1&2)
- (C) Copies of all instruments to be used.

*If this proposal is part of a grant proposal, include a copy of the proposal and all recruitment material.

- (D) The consent form that you will use in the study (see part 3 for more information.)
- (E) Certificate of Completion of Human Subjects Protection Training for all personnel involved in the project, including students who are involved with testing or handling data, unless already on file with the IRB. Training link: (<http://phrp.nihtaining.com/users/login.php>.)
- (F) IRB Security of Data Agreement: (<http://www.lsu.edu/irb/IRB%20Security%20of%20Data.pdf>)

1) Principal Investigator: DANA BROWNE Rank: PROFESSOR.
Dept: PHYSICS ASTRONOMY Ph: 578-6843 E-mail: pbrowne@lsu.edu

2) Co Investigator(s): please include department, rank, phone and e-mail for each

Rebecca Branton - LaMSTI Program, Graduate Student
(225)936-8654
rbrant2@lsu.edu

IRB#	LSU Proposal #
<input checked="" type="checkbox"/>	Complete Application
<input checked="" type="checkbox"/>	Human Subjects Training

3) Project Title: The Effects of Inquiry Based Learning versus Traditional Lecture Style Learning

Study Exempted By:
Dr. Robert C. Mathews, Chairman
Institutional Review Board
Louisiana State University
203 B-1 David Boyd Hall
225-578-8692 | www.lsu.edu/irb
Exemption Expires: 8-17-2014

4) Proposal? (yes or no) No Yes, LSU Proposal Number
Also, if YES, either This application completely matches the scope of work in the grant
OR More IRB Applications will be filed later

5) Subject pool (e.g. Psychology students) 9th grade Biology Students
*Circle any "vulnerable populations" to be used: (children <18; the mentally impaired, pregnant women, the aged, other). Projects with incarcerated persons cannot be exempted.

6) PI Signature Dana Browne Date 6/30/11 (no per signatures)

** I certify my responses are accurate and complete. If the project scope or design is later changes, I will resubmit for review. I will obtain written approval from the Authorized Representative of all non-LSU institutions in which the study is conducted. I also understand that it is my responsibility to maintain copies of all consent forms at LSU for three years after completion of the study. If I leave LSU before that time the consent forms should be preserved in the Departmental Office.

Screening Committee Action: Exempted <input checked="" type="checkbox"/> Not Exempted <input type="checkbox"/>	Category/Paragraph <u>1</u>	
Reviewer <u>Mathews</u>	Signature <u>Robert Mathews</u>	Date <u>8/18/11</u>

VITA

Rebecca A. Branton was born in New Orleans, Louisiana, in May 1978. She attended elementary, middle, and high school in Denham Springs, Louisiana. She graduated from Denham Springs High School in May 1996. She then entered Northeast Louisiana University in August 1996 and earned her degree in Science Education in December 2000. She entered the Graduate School at Louisiana State University Agricultural and Mechanical College in June 2010 and is a candidate for a Master of Natural Sciences. She has been a high school teacher in Ouachita Parish for 1 year, Livingston Parish for one year, and Ascension Parish for the past 7 years. She currently teaches at a high school in Ascension Parish.