



## The European land and inland water CO<sub>2</sub>, CO, CH<sub>4</sub> and N<sub>2</sub>O balance between 2001 and 2005

S. Luyssaert<sup>1</sup>, G. Abril<sup>2</sup>, R. Andres<sup>3</sup>, D. Bastviken<sup>4</sup>, V. Bellassen<sup>1</sup>, P. Bergamaschi<sup>5</sup>, P. Bousquet<sup>1</sup>, F. Chevallier<sup>1</sup>, P. Ciais<sup>1</sup>, M. Corazza<sup>5</sup>, R. Dechow<sup>6</sup>, K.-H. Erb<sup>7</sup>, G. Etiope<sup>8</sup>, A. Fortems-Cheiney<sup>1</sup>, G. Grassi<sup>5</sup>, J. Hartmann<sup>9</sup>, M. Jung<sup>10</sup>, J. Lathière<sup>1</sup>, A. Lohila<sup>11</sup>, E. Mayorga<sup>12</sup>, N. Moosdorf<sup>9</sup>, D. S. Njakou<sup>13</sup>, J. Otto<sup>1</sup>, D. Papale<sup>14</sup>, W. Peters<sup>15</sup>, P. Peylin<sup>1</sup>, P. Raymond<sup>16</sup>, C. Rödenbeck<sup>17</sup>, S. Saarnio<sup>18</sup>, E.-D. Schulze<sup>10</sup>, S. Szopa<sup>1</sup>, R. Thompson<sup>1</sup>, P. J. Verkerk<sup>19</sup>, N. Vuichard<sup>1</sup>, R. Wang<sup>20</sup>, M. Wattenbach<sup>21</sup>, and S. Zaehle<sup>17</sup>

<sup>1</sup>CEA-CNRS-UVSQ, UMR8212 – Laboratoire des sciences du climat et de l’environnement (LSCE), Orme des Merisiers, 91191 Gif-sur-Yvette, France

<sup>2</sup>Laboratoire EPOC, Environnements et Paléoenvironnements Océaniques et Continentaux, UMR5805, CNRS, Université de Bordeaux, Bordeaux, France

<sup>3</sup>Oak Ridge National Laboratory, Environmental Sciences Division, Oak Ridge, TN 37831-6290, USA

<sup>4</sup>Linköping University, The Department of Thematic Studies – Water and Environmental Studies, 586 62 Linköping, Sweden

<sup>5</sup>European Commission, Joint Research Centre, Institute for Environment and Sustainability, Via E. Fermi 2749, 21027 Ispra (VA), Italy

<sup>6</sup>Johann Heinrich von Thünen-Institut, Institute for Agricultural Climate Research, Bundesallee 50, 38116 Braunschweig, Germany

<sup>7</sup>Alpen-Adria Universitaet Klagenfurt-Vienna-Graz, Institute of Social Ecology Vienna (SEC), Schottenfeldgasse 29, 1070 Vienna, Austria

<sup>8</sup>Istituto Nazionale di Geofisica e Vulcanologia, Sezione Roma 2, Via Vigna Murata 605, Italy

<sup>9</sup>Institute for Biogeochemistry and Marine Chemistry, KlimaCampus, University of Hamburg, Bundesstrasse 55, 20146 Hamburg, Germany

<sup>10</sup>Max-Planck Institute for Biogeochemistry, Biogeochemical Processes, P.O. Box 100164, 07701 Jena, Germany

<sup>11</sup>Finnish Meteorological Institute, Climate Change Research, P.O. Box 503, 00101 Helsinki, Finland

<sup>12</sup>University of Washington, Applied Physics Laboratory, Box 355640, Seattle, WA 98105-6698, USA

<sup>13</sup>University of Antwerp, Researchgroup Plant and Vegetation Ecology, Universiteitsplein 1, 2610 Wilrijk, Belgium

<sup>14</sup>University of Tuscia, Department for innovation in biological, agro-food and forest systems (DIBAF), Via S. Camillo de Lellis, snc- 01100 Viterbo, Italy

<sup>15</sup>Wageningen University, Meteorology and Air Quality, Droevendaalsesteenweg 4, 6700 PB, Wageningen, The Netherlands

<sup>16</sup>Yale University, School of Forestry and Environmental Studies, 195 Prospect Street, New Haven, CT 06511, USA

<sup>17</sup>Max Planck Institute for biogeochemistry, Biogeochemical Systems Department, P.O. Box 100164, 07701 Jena, Germany

<sup>18</sup>University of Eastern Finland, Department of Biology and Finnish Environment Institute, the Joensuu Office, PL 111, 80101 Joensuu, Finland

<sup>19</sup>European Forest Institute, Sustainability and Climate Change Programme, Torikatu 34, 80100 Joensuu, Finland

<sup>20</sup>Laboratory for Earth Surface Processes, College of Urban and Environmental Sciences, Peking University, Beijing 100871, China

<sup>21</sup>Helmholtz Centre Potsdam GFZ German Research Centre For Geosciences, Deutsches GeoForschungsZentrum GFZ, Telegrafenberg, 14473 Potsdam, Germany

*Correspondence to:* S. Luyssaert (sebastian.luyssaert@lsce.ipsl.fr)

Received: 23 November 2011 – Published in Biogeosciences Discuss.: 21 February 2012

Revised: 29 June 2012 – Accepted: 23 July 2012 – Published: 24 August 2012

**Abstract.** Globally, terrestrial ecosystems have absorbed about 30 % of anthropogenic greenhouse gas emissions over the period 2000–2007 and inter-hemispheric gradients indicate that a significant fraction of terrestrial carbon sequestration must be north of the Equator. We present a compilation of the CO<sub>2</sub>, CO, CH<sub>4</sub> and N<sub>2</sub>O balances of Europe following a dual constraint approach in which (1) a land-based balance derived mainly from ecosystem carbon inventories and (2) a land-based balance derived from flux measurements are compared to (3) the atmospheric data-based balance derived from inversions constrained by measurements of atmospheric GHG (greenhouse gas) concentrations. Good agreement between the GHG balances based on fluxes ( $1294 \pm 545$  Tg C in CO<sub>2</sub>-eq yr<sup>-1</sup>), inventories ( $1299 \pm 200$  Tg C in CO<sub>2</sub>-eq yr<sup>-1</sup>) and inversions ( $1210 \pm 405$  Tg C in CO<sub>2</sub>-eq yr<sup>-1</sup>) increases our confidence that the processes underlying the European GHG budget are well understood and reasonably sampled. However, the uncertainty remains large and largely lacks formal estimates. Given that European net land to atmosphere exchanges are determined by a few dominant fluxes, the uncertainty of these key components needs to be formally estimated before efforts could be made to reduce the overall uncertainty. The net land-to-atmosphere flux is a net source for CO<sub>2</sub>, CO, CH<sub>4</sub> and N<sub>2</sub>O, because the anthropogenic emissions by far exceed the biogenic sink strength. The dual-constraint approach confirmed that the European biogenic sink removes as much as  $205 \pm 72$  Tg C yr<sup>-1</sup> from fossil fuel burning from the atmosphere. However, This C is being sequestered in both terrestrial and inland aquatic ecosystems. If the C-cost for ecosystem management is taken into account, the net uptake of ecosystems is estimated to decrease by 45 % but still indicates substantial C-sequestration. However, when the balance is extended from CO<sub>2</sub> towards the main GHGs, C-uptake by terrestrial and aquatic ecosystems is offset by emissions of non-CO<sub>2</sub> GHGs. As such, the European ecosystems are unlikely to contribute to mitigating the effects of climate change.

## 1 Introduction

Globally, terrestrial ecosystems have absorbed about 30 % of anthropogenic CO<sub>2</sub> emissions over the period 2000–2007 (Canadell et al., 2007; Le Quéré et al., 2009). The fact that the inter-hemispheric gradient of CO<sub>2</sub>, δ<sup>13</sup>C, and O<sub>2</sub> in the atmosphere is smaller than predicted from fossil fuel emissions and atmospheric transport alone (Ciais et al., 1995; Keeling et al., 1995; Tans et al., 1990) suggests that a significant fraction of terrestrial carbon sequestration must be north of the Equator. Using vertical profiles of atmospheric CO<sub>2</sub> concentrations as a constraint in atmospheric inversions, Stephens et al. (2007) inferred that the magnitude of the total northern land uptake ranges between  $-900$  and  $-2100$  Tg C yr<sup>-1</sup>. This range was confirmed through atmospheric inversions

( $-1100$  to  $-2500$  Tg C yr<sup>-1</sup>) and land-based accounting ( $-1400$  and  $-2000$  Tg C yr<sup>-1</sup>) (Ciais et al., 2010a). By assuming that carbon uptake is evenly distributed across the land surface, we obtain a threshold value against which the actual uptake can be compared. Under the assumption of a uniform uptake, the European continent, as defined in this synthesis ( $5 \times 10^6$  km<sup>2</sup>; see below), would absorb about 5 % or equivalently  $-45$  to  $-105$  Tg C yr<sup>-1</sup>.

Early estimates indicated that carbon uptake ( $-135$  to  $-205$  Tg C yr<sup>-1</sup>) (Janssens et al., 2003) of the European ecosystems extending to the Ural Mountains ( $9 \times 10^6$  km<sup>2</sup>) was indeed close to the average Northern Hemisphere sink (i.e.  $-90$  to  $-210$  Tg C yr<sup>-1</sup> for that area). More recent estimates found evidence for a stronger carbon sink of about  $-270$  Tg C yr<sup>-1</sup> (Schulze et al., 2009) for the same region. However, these new estimates also suggest that the climate mitigation effect of this uptake is being compromised by emissions of other greenhouse gases (e.g. CH<sub>4</sub> and N<sub>2</sub>O), leaving little or no total greenhouse gas mitigation for the European continent. Due to differences in methodology and data products, the aforementioned sink estimates cannot be compared against each other and should therefore not be used in support of the hypothesis of an increasing C-sink in Europe. The more recent estimates (Schulze et al., 2009) should be simply considered as an update of the earlier estimates (Janssens et al., 2003), because the new estimates made use of new and probably more realistic cropland models (Ciais et al., 2010c), revised estimates of forest heterotrophic respiration (Luysaert et al., 2010, 2007), incorporated Russian forest inventories (Shvidenko and Nilsson, 2002; Shvidenko et al., 2001) to account for differences in forest management and productivity between EU-25 and eastern Europe, and accounted for soil carbon losses and gains following land-use change (UNFCCC, 2011).

When estimating the GHG balance of Europe, one has to deal with the small-scale variability of the landscape and of emission sources and simultaneously cover the entire geographic extent of the continent. No single technique spans the range in temporal and spatial scales required to produce reliable regional-scale GHG balances. Nevertheless, we believe the problem can be tackled by using an integrated suite of data and models, based on the philosophy that the continental GHG balance must be estimated by at least two independent approaches: one coming down from a larger scale and one coming up from a smaller scale. Alternatively, all information types could be merged simultaneously, an approach that is currently being developed (Rayner et al., 2005).

We present a new compilation of the GHG balance of Europe as defined in Sect. 2.1 following the dual constraint approach in which (1) the atmospheric-based balance derived from inversion informed by measurements of atmospheric GHG concentrations was compared to (2) a land-based balance derived partly from eddy-covariance measurements and (3) a land-based balance derived mainly from ecosystem carbon inventories.

This work builds on earlier compilations by Janssens et al. (2003), Schulze et al. (2010, 2009) and Ciais et al. (2010a) but (1) formalizes the accounting framework, (2) better separates the data sources, which resulted in two independent rather than a single land-based estimate, (3) increases the number of data products and as such presents a more realistic bias estimate and (4) achieves a higher spatial and temporal consistency of the sink strength through accurate accounting and reporting of the spatial and temporal extent of the estimates.

## 2 Methods and material

### 2.1 Spatial and temporal extent of this study

The area under study (Fig. 1) was limited to Europe defined as the landmass containing the EU-27 plus Albania, Bosnia and Herzegovina, Croatia, Iceland, Kosovo, Macedonia, Norway, Serbia, Montenegro and Switzerland. A geographical rather than a political definition was followed. Therefore, overseas territories (e.g. French Guyana) and distant islands (e.g. Spitsbergen; Canary Islands) were excluded from the carbon and GHG budgets whenever possible. It is often not clear whether the fluxes and stock changes from these islands are included in the national statistics underlying the data products used here to compile carbon and GHG budgets. However, this resulted in minor inconsistencies in the spatial extent of the region under study. Also, it is often unclear whether the data for Serbia and Montenegro include Kosovo or not. We assumed they did not and whenever needed applied a bias correction for Kosovo. For each data product, the known anomalies in the spatial extent are indicated in Table 1.

Geographical Europe typically extends as far as the Ural Mountains and thus includes Belarus, Ukraine, the Caucasian republics and part of Russia. Under the RECCAP initiative (Canadell et al., 2011), these states are the subject of a separate synthesis included in this series (Dolman et al., 2012).

Where data availability permitted, carbon and GHG budgets were estimated for two arbitrary time periods: 1996–2000 and 2001–2005. However, especially for the flux-based and inventory-based approaches, the time period of several fluxes and stock changes was limited to a period shorter than the study period or ill-defined when based on a compilation of data with different time frames. Table 1 indicates anomalies in the temporal extent.

### 2.2 Accounting framework for GHG budgets

An accounting framework was developed to infer the C-flux between terrestrial ecosystems and the atmosphere (Fig. 2). The framework is based on a mass balance approach and given that for Europe most of the components have been independently estimated, different accounting schemes (within the same framework) may be used to estimate the variable

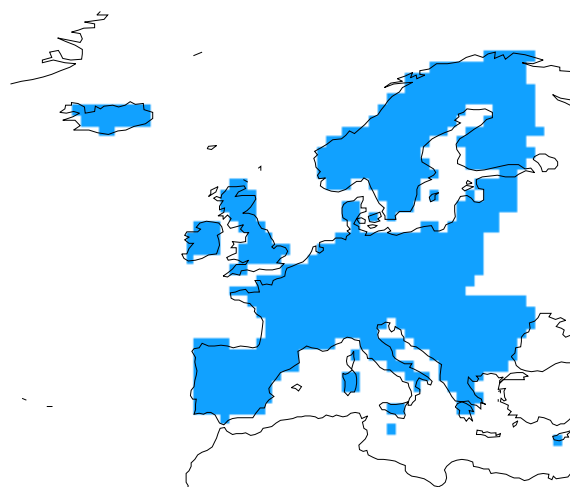

**Fig. 1.** Spatial extent of the region under study including: Albania (ALB), Austria (AUT), Belgium (BEL), Bosnia and Herzegovina (BIH), Bulgaria (BGR), Croatia (HRV), Cyprus (CYP), Czech Republic (CZE), Denmark (DNK), Estonia (EST), Finland (FIN), France (FRA), Germany (DEU), Greece (GRC), Hungary (HUN), Iceland (ISL), Ireland (IRL), Italy (ITA), Kosovo (UNK), Latvia (LVA), Lithuania (LTU), Luxembourg (LUX), Macedonia (MKD), Malta (MLT), the Netherlands (NLD), Norway (NOR), Poland (POL), Portugal (PRT), Romania (ROU), Serbia and Montenegro (SCG), Slovakia (SVK), Slovenia (SVN), Spain (ESP), Sweden (SWE), Switzerland (CHE) and United Kingdom (GBR).

of interest, i.e. the land-to-atmosphere CO<sub>2</sub>, CO, CH<sub>4</sub> and N<sub>2</sub>O flux of Europe. In this study we applied three, largely independent, accounting schemes based on (1) atmospheric inversions, (2) land-based flux measurements and (3) land-based carbon inventories.

Atmospheric inversions used in this study are Bayesian synthesis inversions (Enting, 2002) which combine a priori knowledge of CO<sub>2</sub> fluxes, including natural sources and sinks and fossil fuel CO<sub>2</sub> emissions, with atmospheric CO<sub>2</sub> concentration measurements made at around 100 stations of the surface network and a transport model. Random Gaussian uncertainties are formally propagated for the prior fluxes, the atmospheric measurements and on the ability of the transport model to represent these measurements. A similar approach is applied for the CH<sub>4</sub> and N<sub>2</sub>O inversions. Following the notation introduced in Fig. 2 and Table 1 (see note on the sign convention at the bottom of this section), this can be formalized for CO<sub>2</sub> as

$$\text{Net land to atmosphere flux} = f_{14a} \quad (1)$$

where flux 14a (Fig. 2) represents the change in atmospheric CO<sub>2</sub> as derived from the inversions.

In the land-based approaches, the change in C-stock can be estimated from flux-based estimates of the different components of the budget, or, alternatively, some of the fluxes can be estimated from repeated C-inventories. These approaches

**Table 1.** Spatial and temporal extent of the component fluxes and stock changes of the European C and GHG balance. For the spatial extent, the ISO3166 country is used. Component fluxes are expressed in Tg C yr<sup>-1</sup> for CO<sub>2</sub>, CO and CH<sub>4</sub>, Tg CO<sub>2</sub>-eq C yr<sup>-1</sup> for CH<sub>4</sub> (global warming potential of 23 over 100 yr; shown between brackets) and Tg CO<sub>2</sub>-eq C yr<sup>-1</sup> for N<sub>2</sub>O (global warming potential of 298 over 100 yr; shown between brackets) for the periods 1996–2000 and 2001–2005. Estimates of the different sources of uncertainty and heterogeneity for the fluxes are expressed in Tg C yr<sup>-1</sup> for CO<sub>2</sub>, CO and CH<sub>4</sub> and Tg CO<sub>2</sub>-eq C yr<sup>-1</sup> N<sub>2</sub>O. The uncertainty and heterogeneity for the fluxes and stock changes are expressed in Tg C. The following uncertainties and heterogeneities (defined in Sect. 2.5) are reported: (a) quasi-uniform range of likely model outputs derived from sensitivity analyses (standard deviation of a uniform distribution), (b) normally distributed uncertainty due to the set-up of the inversion model and is typically obtained through the Bayesian approach (standard deviation of a normal distribution), (c) expert estimate of the total uncertainty (%), (d) spatial heterogeneity (standard deviation of a normal distribution), (e) temporal heterogeneity (standard deviation of a normal distribution). The sources are further described in the Supplementary material.

Component	Spatial extent	Temporal extent	1996/2000	2001/2005	Uncertainty and heterogeneity					Product name in SI
					(a)	(b)	(c)	(d)	(e)	
Freshwater ecosystems										
1a River, lake and estuary outgassing CO <sub>2</sub>	Temperate and boreal ecosystems	Undefined	n.a.	73	n.a.	n.a.	50	n.a.	n.a.	Bastviken
	Watersheds draining into the Atlantic Ocean, Arctic, Baltic, North, Mediterranean and Black Sea	Undefined	n.a.	60	n.a.	n.a.	50	n.a.	n.a.	Ciais
1a' River, lake and estuary outgassing CH <sub>4</sub>	Temperate and boreal ecosystems	Undefined	n.a.	1 (11)	n.a.	n.a.	50	n.a.	n.a.	Bastviken A
	Temperate and boreal ecosystems	Undefined	n.a.	4 (16)	n.a.	n.a.	50	n.a.	n.a.	Bastviken B
	All excl. UNK Watersheds draining into the Atlantic Ocean, Arctic, Baltic, North, Mediterranean and Black Sea	Undefined Undefined	n.a.	0.6 (5) 2 (12)	n.a. n.a.	n.a. n.a.	50 50	>0.1 n.a.	n.a. n.a.	Saarnio Abril
1a''' River, lake and estuary outgassing N <sub>2</sub> O 1b Lateral transport to ocean	Temperate and boreal ecosystems	Undefined	n.a.	(10)	n.a.	n.a.	50	n.a.	n.a.	Bastviken
	Watersheds draining into the Atlantic Ocean, Arctic, Baltic, North, Mediterranean and Black Sea	Undefined	n.a.	22	n.a.	n.a.	50	n.a.	n.a.	Ciais
	Watersheds draining into the Atlantic Ocean, Arctic, Baltic, North, Mediterranean and Black Sea	Undefined	n.a.	49	n.a.	n.a.	50	n.a.	n.a.	Raymond
Land ecosystems										
2ab NEE	Global on 1°x1°grid	1983–2008	-905	-876	n.a.	n.a.	50	35	68	Jung
	Global on 0.5°x0.5°grid	1990–2008	-1048	-1030	n.a.	n.a.	50	45	72	Papale
2c Lateral transport to freshwater (excl. DIC)	Watersheds draining into the Atlantic Ocean, Arctic, Baltic, North, Mediterranean and Black Sea	Undefined	n.a.	-72	n.a.	n.a.	50	n.a.	n.a.	Ciais
	Global on 0.5°x0.5°grid	1997–2009	n.a.	4	n.a.	n.a.	50	0.3	1.5	Van der Werf
2d' Ecosystem fires CO <sub>2</sub>	Global on 0.5°x0.5°grid	1997–2009	n.a.	<0.1 (0.3)	n.a.	n.a.	50	>0.1	>0.1	Van der Werf
2d'' Ecosystem fires CO	Global on 0.5°x0.5°grid	1997–2009	n.a.	0.3	n.a.	n.a.	50	>0.1	0.1	Van der Werf
2d''' Ecosystem fires N <sub>2</sub> O	Global on 0.5°x0.5°grid	1997–2009	n.a.	(0.3)	n.a.	n.a.	50	>0.1	0.1	Van der Werf
2e Storms & insect disturbance	All excl. CYP, EST, ISL, LVA, LTU, MLT	Mean for 1950–2000	6	n.a.	n.a.	n.a.	50	n.a.	n.a.	Schelhaas
2fgh Net (decay, vegetation fires and regrowth) land-use change emissions	All excl. ALB, BIH, CYP, MKD, MLT, UNK & SCG	Mean for 2000–2009	n.a.	1	n.a.	n.a.	50	0.8	n.a.	Grassi
2i BVOC emissions	Global on 1°x1°grid	1983–1995	18	n.a.	n.a.	n.a.	50	0.6	n.a.	Lathière
	All excl. ALB, BIH, HRV, CYP, ISL, MKD, MLT, SCG, NOR, UNK & CHE	Mean for 1991–2000	n.a.	(62)	n.a.	n.a.	50	3	n.a.	Wattenbach
2j (a) Cropland emissions N <sub>2</sub> O	All excl. ALB, BIH, HRV, CYP, ISL, MKD, MLT, SCG, NOR, UNK & CHE	Mean for 1991–2000	(64)	n.a.	n.a.	n.a.	50	2	n.a.	Dechow
	All excl. ALB, BIH, HRV, CYP, ISL, MKD, MLT, SCG, NOR, UNK & CHE	Mean for 1991–2000	n.a.	(24)	n.a.	n.a.	50	1	n.a.	Wattenbach
2j (b) Grassland emissions N <sub>2</sub> O	All excl. ALB, BIH, HRV, CYP, ISL, MKD, MLT, SCG, NOR, UNK & CHE	Mean for 1991–2000	(21)	n.a.	n.a.	n.a.	50	1	n.a.	Dechow

Table 1. Continued.

Component	Spatial extent	Temporal extent	1996/2000	2001/2005	Uncertainty and heterogeneity					Product name in SI
					(a)	(b)	(c)	(d)	(e)	
	All excl. ALB, BIH, HRV, CYP, ISL, MKD, MLT, SCG, NOR, UNK & CHE	Mean for 1991–2000	(21)	n.a.	n.a.	n.a.	50	1	n.a.	Vuichard
2k Marsh emissions CH <sub>4</sub>	Watersheds draining into the Atlantic Ocean, Arctic, Baltic, North, Mediterranean and Black Sea	Undefined	n.a.	0.2 (1)	n.a.	n.a.	50	n.a.	n.a.	Abril
2l Peatland emissions CH <sub>4</sub>	SWE, FIN, DEU, GBR	2000–2002	n.a.	2 (15)	n.a.	n.a.	50	n.a.	n.a.	Byrne
	Watersheds draining into the Atlantic Ocean, Arctic, Baltic, North, Mediterranean and Black Sea	Undefined	n.a.	1 (9)	n.a.	n.a.	50	n.a.	n.a.	Abril
2kl Marsh and peatland emissions CH <sub>4</sub> 36	Watersheds draining into the Atlantic Ocean, Arctic, Baltic, North, Mediterranean and Black Sea	Undefined	n.a.	1 (10)	n.a.	n.a.	50	n.a.	n.a.	Abril
2m Agricultural (including cattle) emissions CH <sub>4</sub>	All excl. UNK All excl. ALB, BIH, CYP, MKD, MLT, UNK & SCG	Undefined 1990–2008	n.a. 7 (63)	1 (8) 7 (60)	n.a.	n.a.	50	0.3	0.3	Saarnio UNFCCC
Biological products										
3a (a) Peat harvest for fuel production	CZE, EST, FIN, DEU, HUN, IRL, LTU, NOR, POL, SWE & GBR	1999	10	n.a.	n.a.	n.a.	50	1	n.a.	IPS
3a (b) Wood harvest for fuel production	All excl. UNKR	2001–2010	n.a.	16	n.a.	n.a.	50	1	1	FAO
3b (a) Peat harvest for other uses	CZE, EST, FIN, DEU, HUN, IRL, LTU, NOR, POL, SWE and GBR	1999	4	n.a.	n.a.	n.a.	50	0.4	n.a.	IPS
3b (b) Wood harvest for other uses	All excl. UNK & CYP	2005	n.a.	86	n.a.	n.a.	50	4	n.a.	GFRA
3b (c) Crop harvest for other uses	All excl. UNK	2000	n.a.	378	n.a.	n.a.	50	17	n.a.	Haberl and Krausmann
3b (d) Grazing for other uses	All excl. UNK	2000	n.a.	161	n.a.	n.a.	50	8	n.a.	Haberl and Krausmann
3c Export	All excl. UNK	2000	n.a.	–142	n.a.	n.a.	50	6	n.a.	Haberl and Krausmann
3d Import	All excl. UNK	2000	n.a.	161	n.a.	n.a.	50	6	n.a.	Haberl and Krausmann
3cd Net trade	All excl. UNK	2000	n.a.	19	n.a.	n.a.	50	4	n.a.	Haberl and Krausmann
3e (a) Decay of products in landfill CO <sub>2</sub>	All excl. ALB, BIH, CYP, MKD, MLT, UNK & SCG	1990–2008	1	1	n.a.	n.a.	50	0.1	0.1	UNFCCC
3e (b) Burning of agricultural residues C	All countries	2000	n.a.	28	n.a.	n.a.	50	3	n.a.	Haberl and Krausmann
3e (c) Decay of products outside landfills CO <sub>2</sub> & CH <sub>4</sub>	All excl. UNK	2000	n.a.	529	n.a.	n.a.	50	n.a.	n.a.	Residual Haberl and Krausmann
3e' Decay of products in landfills CH <sub>4</sub>	All excl. ALB, BIH, CYP, MKD, MLT, UNK & SCG	1990–2008	6 (51)	5 (43)	n.a.	n.a.	50	0.2	0.3	UNFCCC
3e''' Decay of products in landfills N <sub>2</sub> O	All excl. ALB, BIH, CYP, MKD, MLT, UNK & SCG	1990–2008	(<0.1)	(<0.1)	n.a.	n.a.	50	<0.1	<0.1	UNFCCC
Burning of biofuels										
4a (a) Peat burning CO <sub>2</sub>	CZE, EST, FIN, DEU, HUN, IRL, LTU, NOR, POL, SWE & GBR	1999	10	n.a.	n.a.	n.a.	15	1	n.a.	IPS
4a (b) Wood and charcoal burning CO <sub>2</sub>	All excl. UNK	2001–2010	n.a.	16	n.a.	n.a.	50	1	1	FAO
4a' (a) Peat burning CH <sub>4</sub>	CZE, EST, FIN, DEU, HUN, IRL, LTU, NOR, POL, SWE & GBR	1999	0.3 (3)	n.a.	n.a.	n.a.	50	>0.1	n.a.	IPS
4a' (b) Wood & charcoal burning CH <sub>4</sub>	All excl. UNK	2001–2010	n.a.	0.5 (4)	n.a.	n.a.	50	>0.1	>0.1	FAO
4a'' (a) Peat burning CO	CZE, EST, FIN, DEU, HUN, IRL, LTU, NOR, POL, SWE & GBR	1999	1	n.a.	n.a.	n.a.	50	0.1	n.a.	IPS
4a'' (b) Wood & charcoal burning CO	All excl. UNK	2001–2010	n.a.	2	n.a.	n.a.	50	0.1	0.1	FAO
4b Other biofuel burning CO <sub>2</sub>	Global on 0.1°x0.1°grid	Undefined	n.a.	53	n.a.	n.a.	50	n.a.	4	Wang
4b' Other biofuel burning CH <sub>4</sub>	Global on 0.1°x0.1°grid	Undefined	n.a.	2 (16)	n.a.	n.a.	50	n.a.	n.a.	Wang
4b'' Other biofuel burning CO	Global on 0.1°x0.1°grid	Undefined	n.a.	5	n.a.	n.a.	50	n.a.	n.a.	Wang

Table 1. Continued.

Component	Spatial extent	Temporal extent	1996/2000	2001/2005	Uncertainty and heterogeneity					Product name in SI
					(a)	(b)	(c)	(d)	(e)	
Fossil fuels										
5a Burning and product use CO <sub>2</sub>	All excl. ALB, BIH, CYP, MKD, MLT, UNK & SCG	1990–2008	1173	1193	n.a.	n.a.	100	53	18	UNFCCC
5a' Burning and product use CH <sub>4</sub>	Region on 1°x1°grid All excl. ALB, BIH, CYP, MKD, MLT, UNK & SCG	1990–2008	1109 4 (34)	1109 3 (29)	n.a.	n.a.	20	51	35	CDIAC UNFCCC
5a'' Burning and product use CO	All excl. ALB, BIH, CYP, MKD, MLT, UNK & SCG	1990–2008	20	15	n.a.	n.a.	50	1	2	UNFCCC
5a''' Burning and product use N <sub>2</sub> O	All excl. ALB, BIH, CYP, MKD, MLT, UNK & SCG	1990–2008	(37)	(29)	n.a.	n.a.	50	2	2	UNFCCC
Geological processes										
6a Silicate and carbonate weathering	Global 1 km × 1 km grid	Undefined	−13	−13	n.a.	n.a.	50	0.6	n.a.	Hartmann and Moosdorf
6b Geothermal-volcanic CO <sub>2</sub>	CZE, DEU, GRC, HUN, ISL, ITA & ESP	Undefined	>10	>10	n.a.	n.a.	25	2	n.a.	Etiopie
6b' Natural hydrocarbon seepage and geothermal exhalations CH <sub>4</sub>	ALB, AUT, BGR, CZE, DNK, FRA, DEU, GRC, HUN, ISL, ITA, NLD, POL, ROU, ESP, CHE & GBR	Undefined	>0.5 (>4)	>0.5 (>4)	n.a.	n.a.	25	0.04	n.a.	Etiopie
6c Cement and lime production	All excl. ALB, BIH, CYP, MKD, MLT, UNK & SCG	1990–2008	35	35	n.a.	n.a.	50	1	1	UNFCCC
6d Dissolved lithogenic carbon from carbonate weathering	Global 1 km × 1 km grid	Undefined	7	7	n.a.	n.a.	50	0.4	n.a.	Hartmann and Moosdorf
Atmospheric processes										
7a Oxidation of non-CO <sub>2</sub> gasses	Global 1.9°x3.75°grid	Mean for 1995–2005	63	63	n.a.	n.a.	50	n.a.	1	Szopa
7b Net non-CO <sub>2</sub> export to adjacent regions										?
7c Dust emission and sedimentation	Global 4°x5°grid	Mean for 20 yr	−0.5	−0.5	n.a.	n.a.	50	n.a.	n.a.	Yúe
7d net BVOC and POC transport to adjacent regions										?
7e net CO <sub>2</sub> transport to adjacent regions										?
7f Rain contained DOC on freshwater ecosystems	All countries	Undefined	−0.4	n.a.	n.a.	n.a.	50	n.a.	n.a.	Willey
7g Rain contained DOC on land ecosystems	All countries	Undefined	−13	n.a.	n.a.	n.a.	50	n.a.	n.a.	Willey
Biomass stocks changes										
8a Above and below ground	All excl. UNK	Mean for 1990–1999 2000–2007	112	135	n.a.	n.a.	50	n.a.	n.a.	Pan
8b Dead wood	All excl. UNK	Mean for 1990–1999 2000–2007	2	2	n.a.	n.a.	50	n.a.	n.a.	Pan
Changes in sediment, soil and biomass stocks										
9a Artificial areas	No data available	Undefined	n.a.	0	n.a.	n.a.	n.a.	n.a.	n.a.	Assumption
9b Arable land and permanent crops	AUT, BEL, DNK, FIN, FRA, DEU, GBR	Undefined	21	21	n.a.	n.a.	50	42	n.a.	Ciais
9c Arable land on drained peatland	FIN, SWE, NLD, NOR, GBR	Undefined	n.a.	24	n.a.	n.a.	50	n.a.	n.a.	Lohila
9d Pastures and mosaics	BEL, GBR, FRA	Undefined	n.a.	−24	n.a.	n.a.	50	16	n.a.	Ciais
9e Forest (incl. biomass)	EU-27	Mean for 2000–2005	n.a.	−121	n.a.	n.a.	50	130	n.a.	Tupek
	All excl. UNK	Mean for 1990–1999 2000–2007	−266	−219	n.a.	n.a.	50	n.a.	n.a.	Pan
9f Forest (incl. biomass) on drained peatland	FIN	Mean for 1990–2008	n.a.	−4	n.a.	n.a.	50	n.a.	n.a.	Lohila
9g Semi-natural vegetation	All excl. UNK	2000	n.a.	−2	n.a.	n.a.	50	n.a.	n.a.	FRA
9h Open spaces and bare soils	No data available	Undefined	n.a.	0	n.a.	n.a.	n.a.	n.a.	n.a.	Assumption
9i Peatlands	SWE, FIN, DEU, GBR	2000–2002	n.a.	−3	n.a.	n.a.	50	n.a.	n.a.	Bryne
9j Water bodies	Temperate and boreal ecosystems	Undefined	n.a.	−41	n.a.	n.a.	50	n.a.	n.a.	Bastviken
	Watersheds draining into the Atlantic Ocean, Arctic, Baltic, North, Mediterranean and Black Sea	Undefined	n.a.	−19	n.a.	n.a.	50	n.a.	n.a.	Ciais

Table 1. Continued.

Component	Spatial extent	Temporal extent	1996/2000	2001/2005	Uncertainty and heterogeneity					Product name in SI
			(a)	(b)	(c)	(d)	(e)			
Harvested product stock change										
10a Wood	All excl. CYP, EST, ISL, LVA, LTU, MLT	2000	-2	n.a.	n.a.	n.a.	50	n.a.	n.a.	Eggers
10b Food	All countries	1990–2009	0	n.a.	n.a.	n.a.	n.a.	n.a.	n.a.	Assumption
Landfill stock change										
11a Wood stock change in landfills	All excl. CYP, EST, ISL, LVA, LTU, MLT	2000	-17	n.a.	n.a.	n.a.	50	n.a.	n.a.	Eggers
11b Food stock change in landfills	EU-27	2008	n.a.	-6	n.a.	n.a.	n.a.	n.a.	n.a.	Decay function
12 Fossil fuel stock change										?
13 Geological stock change										?
Atmospheric stock change										
14a Atmospheric CO <sub>2</sub> stock change	Global, nested grids with resolution 1° × 1° over Europe	2000–2007	n.a.	1239	100	n.a.	n.a.	60	71	Peters
	Global 5° × 4° grid	1996–2008	654	664	30	n.a.	n.a.	29	153	Jena Inversion
	Global 3.75° × 2.5° grid	1996–2004	860	n.a.	35	n.a.	n.a.	43	157	Peylin
	Global 3.75° × 2.5° grid	1988–2008	1226	1076	n.a.	400	n.a.	43	142	Chevallier
	Global 22 regions	1995–2008	772	840	n.a.	n.a.	n.a.	44	137	Transcom
14a' Atmospheric CH <sub>4</sub> stock change	Global 1° × 1° grid	1984–2008	20 (179)	20 (184)	45	50	n.a.	1	0.5	Bousquet
14a'' Atmospheric CO stock change	Global 3.75° × 2.5° grid	2002–2009	n.a.	39	10	n.a.	n.a.	2	22	Fortems-Cheiney
14a''' Atmospheric non-CO <sub>2</sub> C-stock change	Global 1.9° × 3.75° grid	Mean for 1995–2005	90	90	n.a.	n.a.	n.a.	n.a.	3	Szopa
14a'''' Atmospheric N <sub>2</sub> O stock change	Regional 1° × 1° grid	2006–2007	n.a.	(113)	40	45	n.a.	5	1	Thompson
	Regional 1° × 1° grid	2006	n.a.	(152)	n.a.	n.a.	n.a.	6	n.a.	Corazza

are respectively formalized as (notation explained in Table 1 and Fig. 2)

$$\begin{aligned} \text{Net land to atmosphere flux} = & f_{1a} - f_{2a} + f_{2b} + f_{2d} \\ & + f_{2e} + f_{2f} + f_{2g} - f_{2h} + f_{3e} + f_{4a} + f_{4b} + f_{5a} \\ & - f_{6a} + f_{6b} + f_{6c} + f_{7a} - f_{7e} \end{aligned} \quad (2)$$

where the net exchange between inland water and the atmosphere ( $f_{1a}$ ), the net exchange between land ecosystems and the atmosphere ( $-f_{2a} + f_{2b} + f_{2d} + f_{2e} + f_{2f} + f_{2g} - f_{2h}$ ), the decomposition of biological products ( $f_{3e}$ ), the combustion of C-containing fuels ( $f_{4a} + f_{4b} + f_{5a}$ ), the net exchange between the geological stock and the atmosphere ( $f_{6b} + f_{6c} - f_{6a}$ ), the oxidation of non-CO<sub>2</sub> C-gases to CO<sub>2</sub> ( $f_{7a}$ ) and the net CO<sub>2</sub> exchange between adjacent regions ( $-f_{7e}$ ) are accounted for, where  $f_{2a}$  denotes gross primary production (GPP or photosynthesis) and  $f_{2b}$  denotes ecosystem respiration (Re or the sum of autotrophic and heterotrophic respiration). When the eddy-covariance method is used, the net flux  $-f_{2a} + f_{2b}$  is directly measured (further labelled as  $f_{2ab}$  in Table 1) and the component fluxes can only be estimated (Reichstein et al., 2005).

Following the principle of mass conservation, every individual component flux can be calculated based on the sum of the observed stock change and incoming and outgoing fluxes. Stock changes of carbon for fresh water ecosystems ( $f_{9j}$ ), land ecosystems ( $f_{9a}$  to  $f_{9i}$ ), biological products ( $f_{10a}$ ,

$f_{10b}$  and  $f_{11}$ ) and non-CO<sub>2</sub> C-gases ( $f_{14a'}$  and  $f_{14a''}$ ) have been estimated. Estimated stock changes allow calculating the net C-exchange between inland waters and the atmosphere ( $f_{1a}$ ) applying the simple mass balance principle that stock change in the system equals import minus export. The resulting equation is

$$f_{1a} = -f_{1b} - f_{1a'} + f_{2c} + f_{6a} + f_{6d} + f_{7f} + f_{9j} \quad (3)$$

where the individual fluxes are detailed in Table 1. Nevertheless, note that indices without a quote (') denote C-fluxes, and indices with one, two or three quotes refer to CH<sub>4</sub>, N<sub>2</sub>O and CO fluxes respectively. Using the same principle for the net exchange between land ecosystems and the atmosphere

$$\begin{aligned} -f_{2a} + f_{2b} + f_{2d} + f_{2e} + f_{2f} + f_{2g} - f_{2h} = & -f_{2c} - f_{2d'} \\ -f_{2d''} - f_{2i} - f_{2kl} - f_{2m} - f_{3a} - f_{3b} - f_{7c} - f_{7d} + f_{7g} \\ & + f_{9a} + f_{9b} + f_{9c} + f_{9d} + f_{9e} + f_{9f} + f_{9g} + f_{9h} + f_{9i} \end{aligned} \quad (4)$$

for the decomposition of the biological product pool:

$$f_{3e} = f_{10a} + f_{10b} + f_{11} + f_{3b} - f_{3c} + f_{3d} - f_{3e'} \quad (5)$$

and for the oxidation of non-CO<sub>2</sub> C-gases

$$\begin{aligned} f_{7a} = & f_{1a'} + f_{2d'} + f_{2d''} + f_{2i} + f_{2kl} + f_{2m} + f_{3e'} \\ & + f_{4a'} + f_{4a''} + f_{4b'} + f_{4b''} + f_{5a'} + f_{5a''} + f_{6b'} \\ & - f_{7b} + f_{7c} + f_{14a'} + f_{14a''} \end{aligned} \quad (6)$$

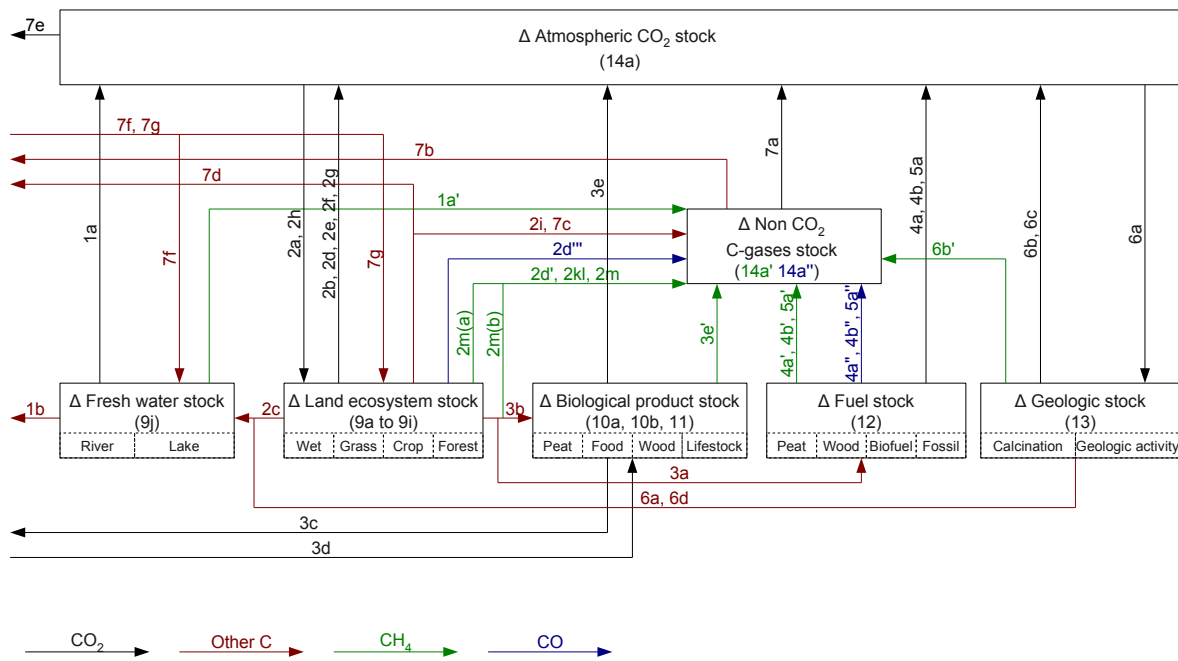

**Fig. 2.** Accounting framework of the C-balance. The framework is based on a mass balance approach and, given that for Europe most of the components have been independently estimated, different schemes may be used to estimate the variable of interest, i.e. the net land to atmosphere exchange. In this study, we applied three quasi-independent accounting schemes based on (1) atmospheric inversions, (2) flux measurements and (3) carbon inventories. Black arrows indicate CO<sub>2</sub> fluxes, green CH<sub>4</sub> fluxes, blue CO and red indicates other C-fluxes. Labelling is explained in Table 1.

Substitution of Eq. (3) to 6 in Eq. (2) results into the following expression for the inventory-based net land to atmosphere flux:

$$\begin{aligned}
 & \text{Net land to atmosphere flux} \\
 & = (-f_{1b} - f_{1a'} + f_{2c} + f_{6a} + f_{6d} + f_{7f} + f_{9j}) \\
 & + (-f_{2c} - f_{2d'} - f_{2d'''} - f_{2i} - f_{2kl} - f_{2m} - f_{3a} - f_{3b} \\
 & - f_{7c} - f_{7d} + f_{7g} + f_{9a} + f_{9b} + f_{9c} + f_{9d} + f_{9e} + f_{9f} \\
 & + f_{9g} + f_{9h} + f_{9i}) + (f_{10a} + f_{10b} + f_{11} + f_{3b} - f_{3c} \\
 & + f_{3d} - f_{3e'}) + (f_{4a} + f_{4b} + f_{5a}) + (f_{6b} + f_{6c} - f_{6a}) \\
 & + (f_{1a'} + f_{2d'} + f_{2d'''} + f_{2i} + f_{2kl} + f_{2m} + f_{3e'} + f_{4a'} \\
 & + f_{4a''} + f_{4b'} + f_{4b''} + f_{5a'} + f_{5a''} + f_{6b'} - f_{7b} + f_{7c} \\
 & + f_{14a'} + f_{14a''}) - f_{7e}
 \end{aligned} \tag{7}$$

where, the brackets in Eq. (7a) delimit the terms for respectively, the net exchange between inland water and the atmosphere, land ecosystems and the atmosphere, biological product pool and the atmosphere, combustion of C-containing fuels, exchange between the geological C-pool and the atmosphere, oxidation of non-CO<sub>2</sub> C-gases and the net CO<sub>2</sub> exchange between adjacent regions. Following elimination of

terms, this expression can be rewritten as

$$\begin{aligned}
 & \text{Net land to atmosphere flux} = -f_{1b} - f_{3a} - f_{3c} + f_{3d} \\
 & + f_{4a} + f_{4a'} + f_{4a''} + f_{4b} + f_{4b'} + f_{4b''} + f_{5a} + f_{5a'} \\
 & + f_{5a''} + f_{6b} + f_{6b'} + f_{6c} + f_{6d} - f_{7b} - f_{7d} - f_{7e} \\
 & + f_{7f} + f_{7g} + f_{9a} + f_{9b} + f_{9c} + f_{9d} + f_{9e} + f_{9f} + f_{9g} \\
 & + f_{9h} + f_{9i} + f_{9j} + f_{10a} + f_{10b} + f_{11} + f_{14a'} + f_{14a''}
 \end{aligned} \tag{8}$$

Given that several inversions used a land surface model to derive the prior fluxes and their errors and that these models are often calibrated and validated against different subsets of eddy-covariance data (see for example Bousquet et al., 2011), many inversion-based and flux-based accounting schemes are not entirely independent. However, the assumptions and subsequent post-processing of the eddy-covariance observations differed substantially between their use in inversion-based and flux-based accounting resulting in quasi-independent schemes. Also, CO<sub>2</sub> inversion and inventory-based schemes share their data sources for fossil fuel emissions and are therefore not entirely independent for this study. Finally, the inventory-based approach cannot make use of stock changes in the geological pool and therefore uses the same data as the flux-based estimate. Inventory and flux-based approaches also share the data for emissions from biofuels.

A similar mass balance approach as used for the CO<sub>2</sub> can be applied to estimate the C and GHG sink in ecosystems and



biological product pools. Also these sinks could be estimated following three quasi-independent approaches: inversion-based, flux-based and inventory-based. Following the notation introduced in Fig. 2 and Table 1, this can be formalized for C as

$$\begin{aligned} \text{Inversion based C sink} &= (f_{14a} + f_{14a'} + f_{14a''}) \\ &+ (-f_{7e} - f_{4a} - f_{4a'} - f_{4a''} - f_{4b} - f_{4b'} - f_{4b''} \\ &- f_{5a} - f_{5a'} - f_{5a''}) + (f_{6a} - f_{6b} - f_{6c}) \end{aligned} \quad (9)$$

where the inversion-based estimates are lowered by subtracting the contributions from combustion of C-containing fuels and atmospheric exchange with the geological stock. The terms contained in the inversion-based estimate, the flux from fuel combustion and the geological flux are delimited by brackets in Eq. (8). For the flux-based approach, the contributions from inland waters, land ecosystems and the biological products (these three components are delimited by brackets) should be summed:

$$\begin{aligned} \text{Flux based C sink} &= (-f_{1a} - f_{1a'} - f_{1b} + f_{2c} + f_{6a} \\ &+ f_{6d} + f_{7f}) + (-f_{2ab} - f_{2c} - f_{2d} - f_{2d'} - f_{2d''} \\ &- f_{2e} - f_{2f} - f_{2g} + f_{2h} - f_{2i} - f_{2kl} - f_{2m} - f_{3a} - f_{3b} \\ &- f_{7c} - f_{7d} + f_{7g}) + (f_{3b} - f_{3c} + f_{3d} - f_{3e} - f_{3e'}) \end{aligned} \quad (10)$$

Finally, an inventory-based estimate is obtained by summing the stock change in inland waters, land ecosystems and the biological product pool (components are delimited by brackets):

$$\begin{aligned} \text{Inventory based C sink} &= f_{9j} + (f_{9a} + f_{9b} + f_{9c} + f_{9d} \\ &+ f_{9e} + f_{9f} + f_{9g} + f_{9i}) + (f_{10a} + f_{10b} + f_{11}) \end{aligned} \quad (11)$$

The flux-based and inventory-based approaches do not share any data and are therefore completely independent.

Equations (1) to (10) follow a mass balance approach where a stock change is calculated as the imported minus the exported mass. Consequently, these equations are generally applicable. It should be noted that the signs shown in Table 1 indicate whether the fluxes are sinks or sources for the atmosphere, except for the lateral fluxes where an atmospheric perspective is meaningless. The atmospheric perspective may differ from the import/export perspective applied in equations 1 to 10. Hence, when using equations 1 to 10 in combination with the data in Table 1, differences in sign convention need to be accounted for.

### 2.3 Balance closure

The mass balance approach introduced in Sect. 2.2 supports internal consistency checks. Stock-based changes in carbon content of inland aquatic ecosystems, land ecosystems, biological products and atmospheric pools obtained from inventories or inversions were compared to their flux-based equivalents. This approach is formalized in Eq. (3) for inland aquatic ecosystems, Eq. (4) for land ecosystems, Eq. (5) for

the biological product pool and Eq. (6) for the atmospheric pool of non-CO<sub>2</sub> gasses.

### 2.4 Boundaries of the GHG budget

The GHG budget is determined by three boundaries: the spatial, the temporal and the accounting boundary. In this study, we used a single spatial boundary (see Sect. 2.1) and two temporal boundaries (see Sect. 2.1). The accounting boundary describes the components that are included in the budget (Fig. 2). However, each of the included components has its own spatial boundaries (e.g. depth to which soil carbon is measured in inventory studies) and its own accounting boundaries. Given that these boundaries are often method-dependent, we choose to specify them in the supplementary material describing the data products (see Supplement).

### 2.5 Data products

All data products used in this study are described in the supplementary material providing details on the underlying observations, processing done by the data owner, uncertainty estimates and post-processing done in this study in addition to literature references.

### 2.6 Uncertainty estimates and error propagation

For data products that were subject of a formal uncertainty analysis, these uncertainty estimates were propagated in the balance computations. However, for the vast majority of the data products, no formal uncertainty analysis was available. For those products, we assumed a normal uncertainty distribution with 95 % uncertainty interval amounting to 100 % of the flux estimate (thus 1 standard deviation is ~50 % of the flux estimate). This imposed uncertainty was also propagated in the balance computations.

In addition to the uncertainty, we quantified the spatial and temporal heterogeneity of the data product for the region (Table 1). Spatial heterogeneity was defined as the between-country heterogeneity of the annual flux of the first year of the sampling period. The country level was the smallest common unit across the different data products. Temporal heterogeneity was calculated as the interannual variability of the aggregated flux of the region under study. The heterogeneity estimates (one standard deviation) are simply reported but not used in any of the uncertainty estimates.

At the global scale, the current uncertainty (one standard deviation) on fossil fuel combustion emissions is 0.5 Pg C yr<sup>-1</sup>, while the annual CO<sub>2</sub> growth rate is known with an a precision of 0.2 Pg C yr<sup>-1</sup>. The growth rate is the sum of the fossil fuel emissions, net fluxes between oceans and atmosphere and the net fluxes between atmosphere and inland waters, land and biological product pools. The lower uncertainty on the growth rate thus implies that there is a negative covariance between uncertainties of the aforementioned net fluxes and those of fossil fuel emissions. Over a region

where both natural fluxes and fossil fuel combustion emissions co-exist, like western Europe, error reduction on each flux term would depend on the prior error correlation structure specific to each flux (assuming the fossil fuel emission prior errors were formally prescribed). In turn, the correlation structure depends on the network density and location of stations with respect to fossil fuel CO<sub>2</sub> emission centers and to the more diffuse but regionally intense natural biospheric CO<sub>2</sub> fluxes.

In the RECCAP CO<sub>2</sub> inversions, however, the (a posteriori) optimized flux does not account for the prior flux uncertainties of fossil fuel emissions. In other words, each inversion prescribes to the atmospheric transport model fossil fuel emissions of which the global magnitude and spatio-temporal distribution are assumed to be perfectly known. Consequently, the a posteriori uncertainty of these inversions is ill-defined. Some inversions try to partly overcome this issue by reporting two error components. The first component describes a quasi-uniform range of likely model outputs and is derived from sensitivity analyses (Table 1). The second component describes a normally distributed uncertainty and is determined by the set-up of the inversion model and is typically obtained through a Bayesian approach. For each inversion, these components depend on each other and the former should be within the bounds of the latter, if the latter is well-defined.

In order to account for the uncertainty in the regional fossil fuel CO<sub>2</sub> emission, we adjusted the uncertainty of the CO<sub>2</sub> inversions in this study. To do so, we added the one standard deviation uncertainty, 20 Tg C yr<sup>-1</sup>, from fossil fuel inventories (Table 1) to the European fossil fuel CO<sub>2</sub> emission (5a in Fig. 2) to the one standard deviation on the net land to atmosphere CO<sub>2</sub> flux (14a in Fig. 2) returned by inversions. Since the only inversion that estimated an a posteriori error on flux 14a is the one of Chevallier et al. (2010), we used this error of 400 Tg C yr<sup>-1</sup> as the default for each other inversion (Fig. 1 from Ciais et al., 2010a supports the fact that an error of 400 Tg C yr<sup>-1</sup> encompasses the between-model spread of different inversion model results for the flux 14a). Assuming errors on (14a) and (5a) to be independent, which possibly is an overestimate given the likelihood of negative covariances discussed above, we obtain an error on the residual land to atmosphere flux (14a)–(5a) issued from inversions of 400 Tg C yr<sup>-1</sup>.

The probability distribution of the uncertainties was assumed to be normal with mean and standard deviation equal to the reported values. Probability distributions were fully accounted for in the aggregated fluxes by means of simulations based on Monte Carlo techniques. Within each realization of the 6000 Monte Carlo simulations that were performed, (sub)totals were computed from randomly selected realizations of the component fluxes. Mean and standard deviations of the (sub)totals were taken from their probability distribution based on 6000 realizations.

## 2.7 Best available estimate

The inversion-based, inventory-based and flux-based estimates were used to obtain a single “best available estimate”. The Bayesian theorem was used to calculate the posterior density of the flux estimates by informing a vague normally distributed prior with extremely large variance with the flux estimates from the three aforementioned sources. The posterior density was approximated through Markov Chain Gibbs sampling making use of WinBUGS software (Spiegelhalter et al., 2002).

## 2.8 Life cycle analysis

We performed a basic country-based life cycle analysis of the CO<sub>2</sub> cost of land management including the following processes: (a) agricultural activities (ploughing, harrowing, cultivation and planting); (b) production and application of fertilizer; (c) production and application of herbicide (glyphosate); (d) thinning, harvesting and planting of forest; (e) transport of roundwood; and (f) transport of firewood. Emission factors were retrieved from Ecoinvent database (Frischknecht et al., 2007). Fertilizer and herbicide consumption are respectively based on European Fertilizer Association on fertilizer consumption in the EU between 2006 and 2007 (EFMA, 2007). Wood harvest comes from the FAO (2008). Although the time frames of these data are not exactly in line with the time frame of the study, this inconsistency was thought to be of minor importance given the assumptions made in the life cycle analysis.

For cropland the following assumptions were made: each cropland is ploughed, harrowed, planted, cultivated, fertilized, sprayed and harvested annually. Grassland is ploughed and harrowed every 10 yr and cultivated and fertilized every year. In the absence of specific data, the CO<sub>2</sub> cost of fertilizer production was distributed over crop and grassland assuming that grasslands received half the dose of croplands. One percent of the forestland was harvested and planted, and 10 % was thinned each year. The harvested wood was transported over a distance of 80 km if used as industrial roundwood. Firewood was transported over a distance of 40 km.

## 3 Results and discussion

### 3.1 Inversion-derived net land to atmosphere GHG fluxes

A subset of inversions, optimized for Europe, was selected to compile the European CO<sub>2</sub>, CH<sub>4</sub>, CO and N<sub>2</sub>O budgets (Tables 1 and 2). Despite the effort in harmonizing the spatial and temporal extent, the different inversions resulted in largely different estimates of the land to atmosphere flux ranging from 654 Tg C yr<sup>-1</sup> to 1239 Tg C yr<sup>-1</sup> for CO<sub>2</sub> (Chevallier et al., 2010; Peters et al., 2010; Peylin et al., 2005; Rödenbeck et al., 2003). For N<sub>2</sub>O the two available

inversions converged to within 25 % of each other. Although at first this looks very encouraging, it should be noticed that both inversions largely used the same observations and a priori fluxes (Corazza et al., 2011; Thompson et al., 2011) so that the difference between the inversions is most likely due to differences in atmospheric transport and the definitions for the prior uncertainties. For CH<sub>4</sub> (Bousquet et al., 2006) and CO (Fortems-Cheiney et al., 2011), just a single inversion was used and therefore inter-model variability could not be estimated. Furthermore, inversions provide only a top-down estimate for the regions constrained by the observations. For N<sub>2</sub>O the constrained region was smaller than the region under consideration (Corazza et al., 2011).

The land to atmosphere flux of GHGs determines to a large extent the rate of accumulation of GHGs in the atmosphere, and its interannual variability modulates the year-to-year growth rate of GHGs and is thus of special interest to the climate system. Also, interannual variability hints at the sensitivity of the land surface to climate variability and, therefore, may provide prognoses about future land surface responses to climate change. For example, the 2003 heat wave over Europe was instrumental in understanding how the land surface may respond to future climate (Ciais et al., 2005) for which similar events are predicted to become more frequent (Stott et al., 2004). The interannual variability of Europe was studied by simultaneously considering two characteristics: (1) the absolute value of the land to atmosphere flux  $\mu_j(\mu_i(|\text{Flux}_{ij}|))$  and (2) the mean interannual variability of the land to atmosphere flux  $\mu_j(\sigma_i(|\text{Flux}_{ij}|))$ , where  $i$  indicates the pixel and  $j$  indicates the data product. The first characteristic identifies regions where the land to atmosphere flux is potentially important for the climate system, whereas the second characteristic identifies regions where the interannual variability is expected to be large. Combining both characteristics in a single variable (Fig. 3) allows the regions to be distinguished that contribute most to the year-to-year variability in atmospheric CO<sub>2</sub> concentration.

For both periods (1996–2000 and 2001–2005), the net land to atmosphere flux in Scandinavia is a small contributor and the central region appears as an important contributor to the interannual variability in atmospheric CO<sub>2</sub> concentration over Europe. A similar latitudinal pattern in interannual variability was observed for deciduous forests but contradicted for evergreen forests based on observations from 39 Northern Hemisphere eddy-covariance sites located at latitudes ranging from 29° N to 64° N (Yuan et al., 2009). A comparison between two deciduous and one evergreen site suggests that deciduous forests may contribute disproportionately to variability in atmospheric CO<sub>2</sub> concentrations within the Northern Hemisphere (Welp et al., 2007). Given the higher abundance of deciduous forests in central and southern compared to northern Europe, this finding may help to explain the observed spatial pattern (Fig. 3) in interannual variability. However, it should be noted that the observed higher variability for deciduous trees compared to evergreen is pre-mature

given that only three sites were investigated (Welp et al., 2007).

Rather than being an ecosystem property, the interannual variability in ecosystem productivity may be due to differences in weather patterns between central and northern Europe. Such a difference could for example be determined by the North Atlantic Oscillation (NAO) (Hoerling et al., 2001). In some years, the NAO pushes the Mediterranean climate southward resulting in wet weather in central and Mediterranean Europe. Other years, the NAO allows a more northern occurrence of the Mediterranean climate resulting in dry weather in central Europe (Hurrell, 1995). Differences in the spatial extent of the summer and winter NAO (Linderholm et al., 2009) may contribute to the observed north-south trend in interannual variability of the land to atmosphere CO<sub>2</sub> flux.

The inversion-derived interannual variability over Europe is sensitive to the lack of observational constraint on fluxes and imperfect knowledge of the prior flux estimates. Atmospheric inversions are forced to achieve mass balance closure. The inversions may achieve mass balance closure by simply attributing the residual fluxes to the least constrained regions. In Europe, the tall tower network that is used to constraint the inversions is less dense in northern, southern and eastern compared to central Europe (Ramonet et al., 2010). Contrary to the observed low variability in northern Europe, this set-up of the inversions is expected to assign the residual fluxes and thus the highest variability to northern and southern Europe. However, in line with the set-up of the inversions, the inversions assigned a high variability to eastern Europe (EST, LVA, LTU and POL), a region poorly constrained by measurements. Therefore, the observed pattern in eastern Europe could reflect the state of the art in inversion rather than a biological phenomenon.

## 3.2 Eddy-covariance and inventory-based net land to atmosphere GHG fluxes

### 3.2.1 Land-use and surface area

The study region has a surface area of  $5 \times 10^6$  km<sup>2</sup>, of which all of Europe except Switzerland is being accounted for in the CORINE database. The dominant land cover is forest (35 %) followed by cropland (25 %) and grassland (18 %). Estimates for forest area differ at most 12 % for the EU-25 when FAO and CORINE are compared. This difference is likely explained by CORINE classifying part of the harvested forest as semi-natural vegetation. While different sources (e.g. CORINE versus FAO) agree on the importance of forest and cropland (estimates differ at most 6 % for the EU-25), such convergence is absent for grazing land with estimates diverging by more than 20 % for the EU-25, which contains the best documented nations of Europe. This uncertainty is caused by whether the classification of grazing land includes only permanent grasslands (e.g. permanent pastures), which are intensively and continuously managed (i.e. mowing or

**Table 2.** Carbon (Tg C yr<sup>-1</sup>) and GHG (Tg C in CO<sub>2</sub>-eq yr<sup>-1</sup>) balance for CO<sub>2</sub>, CO, CH<sub>4</sub> and N<sub>2</sub>O between 2001 and 2005 estimated from inversions (Eq. 1), inventories (Eq. 7) and flux-based approaches (Eq. 2; only for CO<sub>2</sub>). Fluxes per unit area were calculated for a European surface area of 5 035 147 km<sup>2</sup>.

			CO <sub>2</sub>	CO	CH <sub>4</sub>	N <sub>2</sub> O	Total
Inversion-based	C-balance	Tg C yr <sup>-1</sup>	896 ± 400	39 ± 10	20 ± 15	–	995 ± 400
		Tg C m <sup>-2</sup> yr <sup>-1</sup>	178 ± 80	8 ± 2	4 ± 3	–	197 ± 80
	GHG-balance	Tg C in CO <sub>2</sub> -eq yr <sup>-1</sup>	896 ± 400	–	184 ± 135	130 ± 70	1210 ± 405
		Tg C in CO <sub>2</sub> -eq m <sup>-2</sup> yr <sup>-1</sup>	178 ± 80	–	37 ± 27	26 ± 14	240 ± 80
Inventory-based	C-balance	Tg C yr <sup>-1</sup>	993 ± 190	23 ± 5	21 ± 5	–	1037 ± 190
		Tg C m <sup>-2</sup> yr <sup>-1</sup>	197 ± 38	5 ± 1	4 ± 1	–	205 ± 38
	GHG-balance	Tg C in CO <sub>2</sub> -eq yr <sup>-1</sup>	993 ± 190	–	181 ± 45	125 ± 35	1299 ± 200
		Tg C in CO <sub>2</sub> -eq m <sup>-2</sup> yr <sup>-1</sup>	187 ± 107	–	36 ± 9	25 ± 7	258 ± 40
Flux-based	C-balance	Tg C yr <sup>-1</sup>	988 ± 540	–	–	–	1031 ± 540
		Tg C m <sup>-2</sup> yr <sup>-1</sup>	197 ± 107	–	–	–	206 ± 107
	GHG-balance	Tg C in CO <sub>2</sub> -eq yr <sup>-1</sup>	988 ± 540	–	–	–	1294 ± 545
		Tg C in CO <sub>2</sub> -eq m <sup>-2</sup> yr <sup>-1</sup>	197 ± 107	–	–	–	257 ± 108
Best estimate	C-balance	Tg C yr <sup>-1</sup>	891 ± 155	26 ± 4	21 ± 5	–	938 ± 155
		Tg C m <sup>-2</sup> yr <sup>-1</sup>	177 ± 31	5 ± 1	4 ± 1	–	188 ± 31
	GHG-balance	Tg C in CO <sub>2</sub> -eq yr <sup>-1</sup>	891 ± 155	–	179 ± 119	126 ± 31	1160 ± 160
		Tg C in CO <sub>2</sub> -eq m <sup>-2</sup> yr <sup>-1</sup>	177 ± 31	–	36 ± 60	25 ± 6	232 ± 155

grazing), or also natural or semi-natural vegetation that is extensively grazed.

Where the CORINE land cover classes account for wetlands, it is important to distinguish between marshes and peatland and, more specifically, between disturbed and undisturbed peatland. For GHG budgets, distinguishing between these management types is essential because the undisturbed peatland typically acts as a GHG sink, whereas the disturbed peatland under cropland and forests often acts as a GHG source because of enhanced decomposition following harvest, ploughing and/or drainage. The areas for different land uses on peatland have been taken from Joosten (2010). Although not explicitly reported by Joosten (2010), for this study, the areas were assumed constant between 1996 and 2005.

### 3.2.2 Eddy covariance-based net land to atmosphere flux

The current eddy-covariance tower network is equipped to record the CO<sub>2</sub> exchange between land and atmosphere (this flux is also known as NEE in the sense of Chapin et al. (2005)). Although an eddy covariance-based CH<sub>4</sub> network is emerging, at present only very few sites report other greenhouse gas fluxes than CO<sub>2</sub>. Therefore, our eddy covariance-based estimates are limited to CO<sub>2</sub> exchange.

At the site scale, the scale for which eddy-covariance measurements are available, CO<sub>2</sub> is exchanged with neighbouring sites (i.e. lateral CO<sub>2</sub> transport, harvest and trade), the underlying soil matrix and the overlying atmosphere. The typical eddy-covariance tower set-up records only small-scale vertical exchange between ecosystem and atmosphere.

Consequently, NEE estimates need to be corrected for lateral transport and leaching from the soil matrix to obtain the ecosystem carbon sink. Accounting is further complicated by the fact that (Körner, 2003) (1) C, CH<sub>4</sub> and CO<sub>2</sub> are exported to neighbouring ecosystems that are not part of the eddy-covariance network, i.e. inland water and product pools (Fig. 2). Therefore, lateral fluxes and the CO<sub>2</sub> exchange between these ecosystems and the atmosphere also need to be accounted for by additional measurements. (2) For forests and grasslands, the network is biased towards uniform established ecosystems. Hence, newly established ecosystems following land-cover change need to be separately accounted for through land-cover statistics. (3) Eddy-covariance measurements are not made during fires to prevent the equipment from being damaged; fires emissions thus need to be separately accounted for typically through the use of emission factors that depend on burning intensity. (4) Only in recent years, an eddy-covariance network over urban and industrial areas has been under development. Therefore, fossil fuel emissions need to be separately accounted for through fossil fuel emission inventories. (5) The eddy-covariance network is not globally representative, but, given its density over Europe, this is likely a minor issue for estimating mean fluxes over the study region (Sulkava et al., 2011). Equation (2) and Fig. 2 show how issues 1 to 4 were addressed in the accounting framework.

Despite being well documented that annual NEE poorly correlates to climate and is more likely driven by site disturbance such as harvest, grazing, thinning, fire, ploughing, etc. (Luysaert et al., 2007), for a given site, NEE fluxes at high temporal resolutions (i.e. hourly to monthly) are (partly)

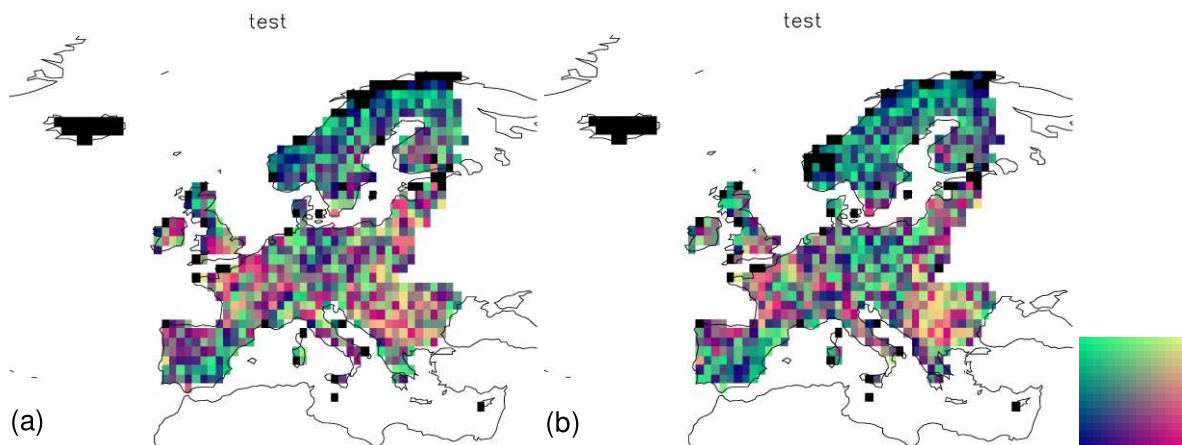

**Fig. 3.** Relative importance of the inversion-derived interannual variability of the CO<sub>2</sub> flux for the two periods under study: (a) 1996–2000 and (b) 2001–2005. The colour scale ranging from blue to green (y-axis) indicates an increasing magnitude of the interannual variability where the scale ranging from blue to purple (x-axis) indicates an increasing importance of the CO<sub>2</sub> flux. Hence, blue pixels indicate regions with small CO<sub>2</sub> flux characterized by a small interannual variability of this flux, purple pixels show regions where the flux is important but characterized by low interannual variability and green pixels have high interannual variability but small CO<sub>2</sub> fluxes.

driven by meteorology (Baldocchi, 2008; Law et al., 2002). Jung et al. (2011) and Papale et al. (2003) used this observation to upscale eddy-covariance measurement to the region. Nevertheless, these authors caution for the lack of spatially explicit disturbance data in their upscaling approach and the substantial uncertainty of their data products (Jung et al., 2009, 2011).

For the region and period under consideration, both eddy covariance-based estimates (Table 1), using almost the same data but different statistical methods, converged at  $-965 \text{ Tg C yr}^{-1}$  within 10% (one standard deviation). Not surprisingly, the estimates indicate that the European land surface consistently takes up CO<sub>2</sub> from the atmosphere. Interannual variability was estimated at 70% (one standard deviation) and was tightly related to meteorology. Although the spatial variability in NEE is thought to be driven by disturbances, the relationship between the temporal variability in NEE and meteorology may be real (Baldocchi, 2008; Law et al., 2002). Nevertheless, the strength of this relationship is most likely an artefact of the fact that the upscaling makes use of remotely sensed fraction of photosynthetic active radiation (fpar) and meteorological data (Jung et al., 2011). Following accounting for fluxes not measured by the eddy-covariance technique (Eq. 2), the net land to atmosphere flux for CO<sub>2</sub> was estimated at  $-988 \pm 540 \text{ Tg C yr}^{-1}$  between 2001 and 2005. Several of the flux estimates were temporally unresolved. Hence, the interannual variability of the net land to atmosphere flux could not be estimated.

### 3.2.3 Inventory-based net land to atmosphere flux

Alternatively, net land to atmosphere fluxes of CO<sub>2</sub>, CH<sub>4</sub> and CO can be estimated from repeated C-inventories often in conjunction with deterministic models (e.g. Tupek et

al., 2010; see also Supplement) and flux measurements to complete the inventory measurements (see Methods and material). This approach has been formalized in Eq. (7). Although this appears as the most straightforward of the three applied approaches to estimate the net land to atmosphere flux, the representativeness of the European estimates may be hampered by data scarcity (see Supplement). For example, changes in soil carbon for the entire territory are based on a rather limited number of sampling plots for croplands (Ciais et al., 2010c) and grasslands (Letten et al., 2005; Goidts and Wesemael, 2007; Soussana et al., 2004; Bellamy et al., 2005) and are based on deterministic modelling for forests (Luysaert et al., 2010; Tupek et al., 2010). Further, spatially explicit estimates are non-existent for several potential hotspots such as drained peatlands, reservoirs and areas under land-use change. For example, it remains unclear what happens with soil carbon following urbanisation.

Assuming that the regions that were inventoried are representative for the spatial domain under study, the European net land to atmosphere flux for CO<sub>2</sub> was estimated at  $993 \pm 190 \text{ Tg C yr}^{-1}$  between 2001 and 2005 (Table 2; Eq. 7). A similar approach was used to estimate the net land to atmosphere fluxes for CH<sub>4</sub>, CO and N<sub>2</sub>O. The land surface is a source for CH<sub>4</sub> and CO of respectively  $23 \pm 5$  and  $21 \pm 5 \text{ Tg C yr}^{-1}$ . For N<sub>2</sub>O the land to atmosphere flux is estimated at  $125 \pm 35 \text{ Tg C in CO}_2\text{-eq yr}^{-1}$  or  $1 \text{ Tg N yr}^{-1}$ . Several of the flux estimates required to estimate the net land to atmosphere flux of CO<sub>2</sub>, CH<sub>4</sub>, CO and N<sub>2</sub>O were temporally unresolved. Hence, the interannual variability was not estimated.

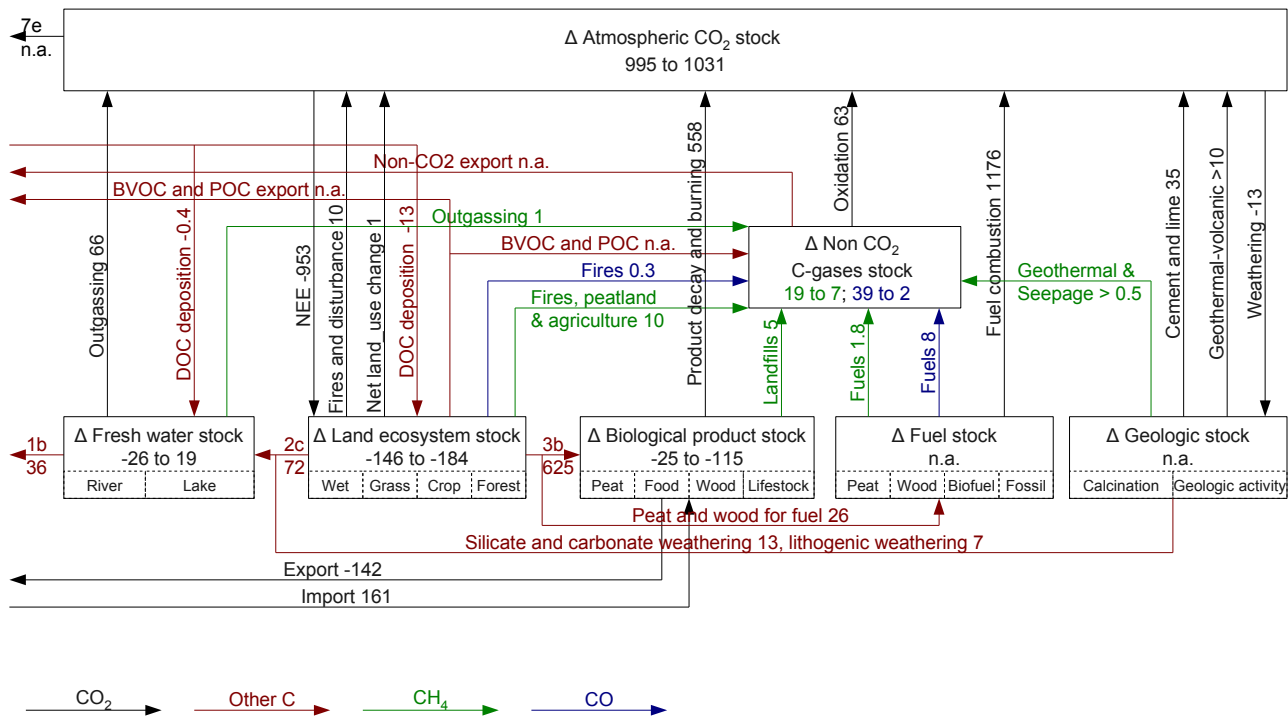

**Fig. 4.** European C-balance for CO<sub>2</sub>, CH<sub>4</sub>, CO and other C-compounds (Tg C yr<sup>-1</sup>) based on diverse data sources including atmospheric inversions, flux measurements and stock inventories. Flux estimates were taken from Table 1, stock changes from Table 3. Black arrows indicate CO<sub>2</sub> fluxes, green CH<sub>4</sub> fluxes, blue CO and red indicates other C-fluxes. Labelling is explained in Table 1.

### 3.2.4 The European C-balance

Data from the inversion-, flux- and inventory-based methods were used to compile a C-balance (Fig. 4) for CO<sub>2</sub>, CO, CH<sub>4</sub> and other C-compounds such as dissolved organic carbon. The diagram shows the dominance in the carbon balance of the combustion of fossil fuels ( $f_{5a}$ ), the net ecosystem productivity of the terrestrial ecosystems ( $f_{2ab}$ ; NEE) and the use of biological products ( $f_{3b}$ ). Most other fluxes are one to three orders of magnitude smaller.

### 3.3 Uncertainty and consistency of the net land to atmosphere GHG fluxes

The uncertainty of the eddy covariance- and inventory-based estimate of the net land to atmosphere flux was estimated from the uncertainty of its components and is thus determined by the assumed uncertainty of 50%. Despite the shared assumption, the uncertainty of the inventory-based estimate was estimated to be almost one-third of that of the flux-based estimate (Table 2). This difference is due to the difference in the magnitude of the fluxes that are used in the balance calculations (i.e. Eq. 2 vs. Eq. 7). Given our assumption, the largest component flux comes with the largest uncertainty. Consequently, the total uncertainty is determined by the uncertainty of the upscaled NEE (2ab; Table 1) in the flux-based approach, whereas the uncertainty

of the inventory-based approach is determined by the uncertainties of fossil fuel burning (5a; Table 1) and the changes in forest carbon (9e; Table 1). Improved uncertainty estimates require formal uncertainty analyses for the upscaled NEE and changes in forest carbon.

The mass balance approach introduced in Sect. 2 supports internal consistency checks. Stock-based changes in carbon content of the aquatic, terrestrial, product and atmospheric pool obtained from inventories or inversions were confronted with their flux-based equivalents (Fig. 2). This approach is formalized for CO<sub>2</sub> in Eqs. (3) to (6), and the balance closure has been reported in Table 3. Balance closure between the stock-based and flux-based estimates is not significantly different from zero mainly because of the wide uncertainty intervals. Hence, our estimates for these components were considered consistent. Consistency is expected to further improve if atmospheric transport to adjacent regions would be accounted for (7b, 7d and 7e in Table 1).

However, in absolute terms the closure gap for the biological product pool (i.e. all harvested biomass and subsequent products such as food, fodder, wood, paper, etc.) is with 88 Tg C yr<sup>-1</sup> important. This inconsistency represents about 40% of the inventory-based change in carbon stock for the region under study. This inconsistency may be due to the lack of dense harvest and herbivory observations for grasslands and croplands. The current budget relies on modelled data (see 3b (c) and 3b (d) in Table 1). Hence, it is expected

**Table 3.** Estimates of C-sinks based on inventory-based stock changes and indirect calculation of stock changes from associated flux estimates. The difference between both estimates is the closure gap and was used as a proxy for the internal consistency of the CO<sub>2</sub>, CO and CH<sub>4</sub> fluxes between 2001–2005. Calculation details are given in the text (Eqs. 3 to 6).

	Stock change (Tg C yr <sup>-1</sup> )		Closure gap (Tg C yr <sup>-1</sup> )
	Inventory-based	Flux-based	
Inland aquatic ecosystems	-26 ± 12	19 ± 56	-50 ± 45
Land ecosystems	-146 ± 85	-184 ± 180	36 ± 590
Biological products	-25 ± 10	-115 ± 195	88 ± 420
Atmospheric non-CO <sub>2</sub> CO	39 ± 10	2 ± 15	35 ± 20
Atmospheric non-CO <sub>2</sub> CH <sub>4</sub>	19 ± 9	7 ± 10	11 ± 11
Atmospheric non-CO <sub>2</sub> All	58 ± 13	9 ± 31	50 ± 36

that the internal consistency of the European C-budget could largely improve by informed emission estimates of biological product pools by measurements.

It should be noted that in this consistency check, two inaccurate fluxes could compensate each other resulting in an apparently high consistency. Consequently, the information content of our balance closure approach is limited as it does not identify which fluxes or stock change estimates need to be further improved to improve the consistency and accuracy of the net land to atmosphere flux.

### 3.4 GHG mitigation of European ecosystems

Irrespective of its mitigation potential, the classification of an ecosystem (or C-pool) as “sink” or “source” may depend on whether an in-situ or atmospheric reference is used. A different classification is typically caused by the magnitude of the lateral C-fluxes. From the atmospheric point of view, croplands and geological pools are CO<sub>2</sub> sinks as they take up CO<sub>2</sub> for respectively growth and weathering. However, from an in-situ perspective, the same croplands and geological pools will be sources: current cropland management in Europe results in decreasing soil C-stocks and weathering dissolves C that is subsequently being lost in run-off and drainage. The opposite happens in landfills and inland waters, where, despite the fact that these land and product uses emit GHG to the atmosphere, the in-situ C-pool is currently increasing in the product pool and sediments respectively. This terminological ambiguity is absent for European forests, grasslands and peatlands, which are sinks, irrespective of the perspective. Fossil fuels are sources from both an in-situ and atmospheric point of view. As the mitigation potential is more closely linked to the in-situ perspective, we used the in-situ perspective to classify ecosystems and pools as sink or sources.

Sink estimates, based on Eqs. (8) to (10), show that the European ecosystems and biological product pools were a C-sink between -356 and -201 Tg C yr<sup>-1</sup> between 2001 and 2005 (Table 4). Individual sink estimates come with large uncertainties ranging between 80 and 330 Tg C yr<sup>-1</sup>. However,

the extremely high and low sink-strengths are in conflict with the inventory-based approach that has a much smaller uncertainty of 80 Tg C yr<sup>-1</sup> and as such puts a tighter constraint on the estimated sink strength. Applying the Bayesian theorem, a sink of -205 ± 72 Tg C yr<sup>-1</sup> was considered the best available estimate as it is consistent with our three independent data sources (i.e. atmospheric measurements, observed stock changes and measured fluxes).

This C-sink in European ecosystems and biological product pools is thought to be mainly driven by changes in atmospheric CO<sub>2</sub>, climate, atmospheric N-deposition, land use (intensity) change and to a minor extent by changes in ozone concentration and diffuse versus direct light flux (Le Quéré et al., 2009). Proper understanding of the drivers, their interaction and their contributions to the current sink is a prerequisite to predict whether the current sink strength will increase, decrease or persist in the future. Spatially explicit sink attribution at the European scale is beyond the capacity of experimental work and can only be achieved by well-validated model-based experiments. For example, model-based experiments could shed light on the effect of large-scale bioenergy production on the current sink strength. Such modelling experiments could extend the time period of data-driven studies (for example, Hudiburg et al., 2011). However, model-based sink attribution is still in its infancy because currently no single large-scale model can deal with all aforementioned factors. At present, multiple model-based experiments have been performed with different models. Hence, the observed sink is attributed to just a limited number of drivers, likely overestimating the importance of the drivers the model accounts for.

JULES (Joint UK Land Environment Simulator), a land surface model integrating climate change and [CO<sub>2</sub>], showed that [CO<sub>2</sub>] increase had a higher impact on the European C-sink than climate (Harrison et al., 2008b). Note that Europe was here defined as continental Europe. Warming was reported to emit C to the atmosphere. This C-source, however, was more than offset by the effect of increasing atmospheric [CO<sub>2</sub>] resulting in a -114 Tg C yr<sup>-1</sup> sink between 1980–2005 (Harrison et al., 2008a). This modelling experiment



**Table 4.** Three quasi-independent estimates of the land-based carbon (Tg C yr<sup>-1</sup>) and GHG (Tg C in CO<sub>2</sub>-eq yr<sup>-1</sup>) balances of Europe between 2001 and 2005. The inversion-based estimate is based on Eq. (8), the flux-based estimate on Eq. (9) and the inventory-based estimate on Eq. (10). The C-balance accounts for CO<sub>2</sub>, CH<sub>4</sub>, CO and other C-fluxes. The GHG balance accounts for CO<sub>2</sub>, CH<sub>4</sub>, CO, other C-fluxes and N<sub>2</sub>O. Fluxes per unit area were calculated for a European surface area of 5 035 147 km<sup>2</sup>.

		C-sink	GHG-sink
Inversion-based	Tg C (in CO <sub>2</sub> -eq) yr <sup>-1</sup>	-356 ± 330	-42 ± 360
	Tg C (in CO <sub>2</sub> -eq) m <sup>-2</sup> yr <sup>-1</sup>	-71 ± 73	-8 ± 72
Inventory-based	Tg C (in CO <sub>2</sub> -eq) yr <sup>-1</sup>	-201 ± 80	105 ± 100
	Tg C (in CO <sub>2</sub> -eq) m <sup>-2</sup> yr <sup>-1</sup>	-40 ± 16	21 ± 20
Fluxes-based	Tg C (in CO <sub>2</sub> -eq) yr <sup>-1</sup>	-196 ± 320	110 ± 330
	Tg C (in CO <sub>2</sub> -eq) m <sup>-2</sup> yr <sup>-1</sup>	-39 ± 44	22 ± 46
Best estimate	Tg C (in CO <sub>2</sub> -eq) yr <sup>-1</sup>	-205 ± 72	95 ± 91
	Tg C (in CO <sub>2</sub> -eq) m <sup>-2</sup> yr <sup>-1</sup>	-41 ± 14	19 ± 18

likely overestimates the effects of climate change and increasing [CO<sub>2</sub>], because it accounted for land-use (intensity) change, N-deposition, increasing atmospheric ozone and diffuse vs. direct light.

Another model experiment performed with a version of the LPJ (Lund Potsdam Jena) land surface model accounting for climate change, increasing atmospheric [CO<sub>2</sub>] and land cover change, found an important effect of land use change over the EU-15 (Zaehle et al., 2007). During the 1990s, 3.3 Tg C yr<sup>-1</sup> were lost to urbanization, 19.3 Tg C yr<sup>-1</sup> to agricultural and 14.5 Tg C yr<sup>-1</sup> to grasslands. Emissions due to land cover change were offset by sequestration of -59.1 Tg C yr<sup>-1</sup> in forest and wood products resulting in a mean annual C-sink of -29 Tg C yr<sup>-1</sup> (Zaehle et al., 2007).

O-CN, a branch of ORCHIDEE (Organizing Carbon and Hydrology in Dynamic Ecosystems) integrating climate change, increasing atmospheric [CO<sub>2</sub>] and the nitrogen cycle, shows that nitrogen deposition considerably alters the attribution of the C-sink to its drivers. Including nitrogen dynamics limited the global sink strength by almost 0.4 Pg C yr<sup>-1</sup> in the N-limited boreal regions, whereas N-deposition was reported to enhance the global terrestrial C-sink by 10 to 20 % (i.e. -0.2 to -0.4 Pg C yr<sup>-1</sup>). Given that no N-effect was simulated for tropical regions, interactions with reactive nitrogen (Nr) substantially contribute to the C-sink in the temperate zone (Zaehle et al., 2010). A similar modelling experiment using a slightly different version of O-CN that also accounts for the effects of land cover change (Zaehle et al., 2011) resulted in a net forest uptake rate due to Nr deposition of 23.5 ± 8.5 Tg C yr<sup>-1</sup> (mean and standard deviation of the temporal heterogeneity for the years 1996–2005). In addition, the Nr effect on unmanaged grasslands accounts for a further sink of 2.8 Tg C yr<sup>-1</sup>. The simulations with O-CN suggest that Nr deposition has played only a minor role in terrestrial C-cycling prior to the 1950s, after which the effect increased in the mid-1980s. The effect has thereafter remained relatively constant with some

inter-annual variations related mainly to the interactions of Nr availability with climatic variability (Zaehle et al., 2011).

A comparison of BIOME-BGC (Global Biome model – Biogeochemical Cycles), JULES, ORCHIDEE and O-CN suggested a continuous increase in carbon storage from 85 Tg C yr<sup>-1</sup> in 1980s to 108 Tg C yr<sup>-1</sup> in 1990s, and to 114 Tg C yr<sup>-1</sup> in 2000–2007 (Churkina et al., 2010). These estimates are for continental Europe and limited to the terrestrial ecosystem sink. The study identified the effect of rising [CO<sub>2</sub>] in combination with Nr-deposition and forest regrowth as the important explanatory factors for this net carbon storage. However, the modelling experiments did not account for changes in the age structure of woody vegetation, a potentially important contributor.

Some modelling experiments zoomed in on a single ecosystem and its specific characteristics. The effect of changes in age structure of forest has been subjected to separate modelling experiments (Bellassen et al., 2011; Zaehle et al., 2006). For Europe, ORCHIDEE-FM (another branch of ORCHIDEE integrating climate change, increasing atmospheric [CO<sub>2</sub>], net forest cover change and changing age structure of forest) shows spatial variation in the main drivers. Locally, climate change and changing age structure often determine temporal changes in the forest C-sink, whereas at the continental scale, increasing atmospheric [CO<sub>2</sub>] drives the increase of the forest sink (Bellassen et al., 2011). A modelling experiment with a similar capacity but making use of a LPJ (Zaehle et al., 2006) instead of ORCHIDEE-FM (Bellassen et al., 2011) found that climate change and increased atmospheric [CO<sub>2</sub>] resulted in a net increase in the vegetation carbon stock of -57 Tg C yr<sup>-1</sup> in the 1990s over the EU-25. Afforestation doubled the sink strength to -118 Tg C yr<sup>-1</sup>. Despite its local importance for determining the carbon balance on the European scale, changes in harvest intensity decreased C-sequestration by 5 Tg C yr<sup>-1</sup> in forest vegetation and thus had a small impact on the European scale. Both Zaehle et al. (2006) and Bellassen et al. (2011) attributed a modest contribution of



changing age structure to the current C-sink, and both models were capable of reproducing large-scale forest inventory statistics.

Contrary to the inventory-based estimates (Table 1), model simulations estimated a small but uncertain CO<sub>2</sub> C-sink in croplands (Ciais et al., 2010b). This sink was attributed mainly to past and current management, and to a minor extent the shrinking areas of arable land consecutive to abandonment during the 20th century (Ciais et al., 2010b). When assessing the effects of rising atmospheric [CO<sub>2</sub>], changing climate, and agro-technology changes on the carbon balance of European croplands, agro-technology changes and varieties selection were found to be largely responsible for the sink rather than rising [CO<sub>2</sub>] and climate change (Gervois et al., 2008). Sink uncertainty for croplands was dominated by unknown historical agro-technology changes (Ciais et al., 2010b; Kutsch et al., 2010; Ceschia et al., 2010) and model structure (Ciais et al., 2010b) with the model potentially missing processes that contribute to the observed C-source (e.g. ploughing). Errors in climate forcing played a minor role (Ciais et al., 2010b).

The above-mentioned modelling experiments limited their simulations to CO<sub>2</sub> uptake and emissions. However, the same European ecosystems and biological product pools that were a CO<sub>2</sub>-sink were a source for CH<sub>4</sub>, CO and N<sub>2</sub>O (Table 2). When converted to a common unit (i.e. Tg C in CO<sub>2</sub>-eq yr<sup>-1</sup>), the C-sink is most likely offset by the global warming potential of CH<sub>4</sub> and N<sub>2</sub>O. As a consequence, the European ecosystems and biological product pools are a GHG source of 105 ± 100 Tg C in CO<sub>2</sub>-eq yr<sup>-1</sup> to the atmosphere and thus contribute to global warming (Table 4). This finding confirms previous data-driven (Schulze et al., 2010, 2009) and model-based (Zaehle et al., 2011) studies.

To our best knowledge, there are no comprehensive attribution studies of the GHG balance. However, global GHG-species-specific studies possibly shed some light on the global drivers of N<sub>2</sub>O and CH<sub>4</sub> emissions. Before 1960, agricultural expansion, including livestock production, may have caused globally significant mining of soil nitrogen, fuelling a steady increase in atmospheric N<sub>2</sub>O (Davidson, 2009). After 1960, the rate of the increase rose, due to accelerating use of synthetic nitrogen fertilizers. Both agricultural expansion and the use of synthetic nitrogen fertilizers are highly relevant for Europe.

The emissions of atmospheric methane were investigated by using two atmospheric inversions to quantify the distribution of sources and sinks for the 2006–2008 period, and a process-based model of methane emissions by natural wetland ecosystems (Bousquet et al., 2011). At the global scale, a significant contribution of CH<sub>4</sub> emissions was thought to come from wetlands in Eurasia where annual changes in precipitation were thought to be the underlying driver (Bousquet et al., 2011). However, other studies put forward other drivers (e.g. more efficient rice production) (Fuu Ming et al., 2011) as unlikely to be important for Europe, or changes

in petroleum production and use (Aydin et al., 2011). It remains to be quantified how relevant these global drivers are in explaining the European CH<sub>4</sub> emissions.

Integrated studies of the interactions of carbon (i.e. CO<sub>2</sub>, CH<sub>4</sub>, BVOC, CO) and nitrogen (N<sub>2</sub>O) dynamics, land use (intensity) changes and environmental changes (e.g. increasing atmospheric [CO<sub>2</sub>], climate change, increasing [O<sub>3</sub>], changes in direct versus diffuse light) are needed to further improve the quantitative understanding of the driving forces of the European land carbon balance. Although such simulations may become available within a couple of years for forest, grasslands or croplands, a single simulation simultaneously accounting for the different ecosystems (including aquatic ecosystems) may not be available within the next 5 yr or so. The major constraints in realizing such simulations are (a) model development in support of such simulations and (b) lack of multi-factorial field experiments that can be used to validate of such model outcome.

### 3.5 Fossil fuel cost of the C-sinks

The carbon sink is often presented as a free service from “nature” to “mankind”, and in this section we test whether this statement is justified for Europe. It has been shown that land management is among the main drivers of the European ecosystem-based sink (See Sect. 3.4). It should, however, be recognized that land management requires the input of energy. Hence, there is a CO<sub>2</sub> cost to realize the ecosystem-based C-sink. In Table 1 this CO<sub>2</sub> cost is accounted for in the following fluxes: 5a “burning and product use CO<sub>2</sub>”, 4a “peat, wood and charcoal burning CO<sub>2</sub>” and 4b “other bio-fuel burning CO<sub>2</sub>”. In this section, we used life cycle analysis (LCA) to estimate how much of the CO<sub>2</sub> emitted through fluxes 4a and 4b and 5a can be allocated to land management.

Based on our LCA assumptions (see Sect. 2.8), we estimated that the CO<sub>2</sub> cost for ecosystem management is 65 Tg C yr<sup>-1</sup> for cropland, 14 Tg C yr<sup>-1</sup> for grassland and 10 Tg C yr<sup>-1</sup> for forest (Table 5). Total emission for land management is thus 89 Tg C yr<sup>-1</sup> which represents less than 10% of the total European emissions from fossil fuel burning. However, when the land sink rather than the fossil fuel emissions are used as a reference, emissions due to land management practices (e.g. ploughing, harvesting, fertilizing, etc.) can no longer be ignored.

Current agricultural ecosystems are a source of 21 Tg C yr<sup>-1</sup> (Table 1), and to create this source at least another 65 Tg C yr<sup>-1</sup> are emitted through energy use for land management (including fertilizer and herbicide production and application). Management of grasslands is a small sink: the ecosystems store about 24 Tg C yr<sup>-1</sup>; their management emits about 14 Tg C yr<sup>-1</sup>. Forest management is doing considerably better: only 0.02 to 0.04 Tg of C are emitted to sequester 1 Tg C in the ecosystem. We hypothesise that in addition to fossil fuels consumed to manage the forest C-sink, the sink strength in European forests is an

**Table 5.** CO<sub>2</sub> cost of land management in Europe based on life cycle analysis. The inventory-based sink was used to estimate the CO<sub>2</sub> cost per unit sink strength.

Land-use type	CO <sub>2</sub> sink (Tg C yr <sup>-1</sup> )	CO <sub>2</sub> cost (Tg C yr <sup>-1</sup> )	CO <sub>2</sub> cost per surface area (g C m <sup>-2</sup> )	CO <sub>2</sub> cost per sink strength (-)
Artificial areas	?	?	?	?
Arable land and permanent crops (excl. drained peatlands)	21	65	59	3.1
Pastures and mosaics	-23	14	11	-0.6
Forested land	-125 to -223	10	6	-0.02 to -0.04
Semi-natural vegetation	-2	?	?	?
Open spaces and bare soils	0	0	-	0
Wetlands	-3	0	0	-∞
Water bodies	-19 to -41	?	?	?

indirect result of high fossil fuel consumption, as has been shown for Austria (Erb et al., 2008; Gingrich et al., 2007). Part of the current forest sink is thought to be a result of society's decreasing dependency on forest biomass resulting in harvest levels well below wood increment. This situation is maintained by the fact that the energy and raw material previously provided by forests have now been substituted by fossil fuel-based energy and products.

It should be noted that undisturbed peatlands are observed to be C-sinks (Table 1) but at no management cost as these systems are typically unmanaged (Table 5). The annual C-balance of undisturbed peatlands is however highly sensitive for weather conditions. For example, summer droughts, which are becoming more frequent, may turn both ombrotrophic and minerotrophic mires into net sources of C (Saarnio et al., 2007). The structure of the management costs of rivers, lakes and reservoirs is somehow different from terrestrial ecosystems as it consists mainly of the cost for constructing canals and dams and maintaining water levels, of which we had insufficient information to estimate their costs.

Since our cost analysis was strictly limited to ecosystem management, subsequent processing of the food and raw material was not included. Such inclusion is likely to change the outcome of the LCA substantially. The CO<sub>2</sub> cost for food processing in the EU-27 was at least 12 Tg C yr<sup>-1</sup> between 2001 and 2005 (item 1.AA.2.E in UNFCCC, 2007) and thus relatively low compared to its production costs. The CO<sub>2</sub> cost of wood processing, especially pulp and paper production, is with 8 Tg C yr<sup>-1</sup> between 2001 and 2005 (item 1.AA.2.D in UNFCCC, 2007) high compared to the production cost of the wood itself. Also the CO<sub>2</sub> costs for managing the biological product pool are expected to be substantial but not included in this LCA. Given the assumptions and the accounting boundary of this LCA, the results should be considered as indicative rather than final. Nevertheless, it clearly demonstrates the point that the European C-sink in ecosystems and biological product pools is not a free service but comes at a considerable CO<sub>2</sub> cost.

#### 4 Outlook

The observation that the net land-to-atmosphere and the land sink estimates are both consistent within their uncertainties is a minimal quality requirement for GHG budgets. If the uncertainty intervals of the different methods would not overlap, the estimates would be in conflict with one another indicating poor data quality or insufficient process understanding. However, overlapping uncertainty intervals, as found in this study, could simply be the result of large uncertainty intervals. Depending on the intended use (e.g. enhancing our understanding of biogeochemical cycling, setting priorities in climate change mitigation policy and the so-called "verification"), different actions may be necessary to improve the GHG budgets.

Although current uncertainties are considerable, little is to be expected from an effort to decrease these uncertainties when the intended use is enhancing our understanding of biogeochemical cycling because the conclusions of subsequent studies (Janssens et al., 2003; Schulze et al., 2010, 2009), all with large uncertainties, already converge. However, much of our large-scale understanding is based on spatially and temporally aggregated fluxes from a geographically restricted area. Increasing the spatial and temporal resolution of the data is expected to bring new insights as such data would support analysing seasonal and interannual variability.

Similarly, the currently large uncertainties should not hamper setting priorities in climate change mitigation policy as subsequent studies agree on the major contributors to both sources and sinks (Janssens et al., 2003; Schulze et al., 2010, 2009). Since the first European GHG budget was compiled, the major sources were identified as fossil fuel burning (for CO<sub>2</sub>, CH<sub>4</sub> and N<sub>2</sub>O), decay of biological products (for CO<sub>2</sub>, CH<sub>4</sub>), importation of biological products (for CO<sub>2</sub>) and agricultural production (for CH<sub>4</sub> and N<sub>2</sub>O). The major sinks in Europe are the exportation of biological products (for CO<sub>2</sub>) and forest biomass accumulation (for CO<sub>2</sub>). Current knowledge requires no further uncertainty reduction to

focus mitigation efforts on the major sinks and sources (see also Sect. 3.5). Nevertheless, the effectiveness of mitigation strategies should be verified. Unless uncertainties are formally analysed and reduced compared to their current level, verification is likely to be meaningless.

At national level, inventories of greenhouse gas emissions and removals from the land use, land-use change and forestry sector (LULUCF), including estimates from 1990 onward, are submitted annually to the UNFCCC, following well-established IPCC methodological guidance (although with some variation in the degree of accuracy and completeness between countries). When these estimates are used to evaluate progress towards the commitments under the Kyoto Protocol (the so-called compliance), independent verification should be provided to ensure that national claims mirror real achievements. In most cases, however, the methods used in UNFCCC inventories cannot be expected to produce the same annual results as the inventory-based, flux-based and inversion-based methodologies. This is mainly because, even when the UNFCCC inventory is complete, in most cases the impact of extreme weather events is not fully taken into account, or it is averaged over longer periods (only sophisticated models, not yet widely used in Europe, may aim to incorporate the full impact of climatic conditions on annual GHG and LULUCF inventories). Furthermore, the current uncertainties of the inversion-, inventory- and flux-based estimates are too large to verify UNFCCC-based estimates at the national or even the aggregated European scale. Several data products lack the spatial resolution to support verification at the national level which is further hampered by the observation that all three estimates presented in this study relied to some extent on UNFCCC data.

Given the heterogeneity of the European land surface, compliance verification will most likely rely on both atmospheric and surface observations where the atmospheric observations will be used to constrain the land surface characteristics for regions that are sparsely sampled. Currently, the atmospheric network over Europe is able to reduce the uncertainty of monthly net biogenic fluxes by as much as 60 % (Broquet et al., 2011), although currently no uncertainty reduction from using atmospheric observations is to be expected for the inventory-based net biogenic flux estimates. The uncertainty of the net land-to-atmosphere estimate could be improved by improving both the atmospheric network and/or by improving the surface observations. Which improvements will result in the largest uncertainty reduction depend on the quality of the atmospheric observations and inversion relative to the quality of the land surface observations.

## 5 Conclusions

This study confirmed that the anthropogenic emissions by far exceed the biogenic sinks and that the European land surface (including inland waters and urban areas) is thus a net source for CO<sub>2</sub>, CO, CH<sub>4</sub> and N<sub>2</sub>O. However, ecosystems do remove a portion of the CO<sub>2</sub> released through fossil fuel burning from the atmosphere. This carbon is sequestered in both terrestrial and inland aquatic ecosystems. Note that, after forests, the aquatic systems are estimated to contribute second most to carbon sequestration, and thus rank above the European croplands and grassland. However, riverine carbon comes predominantly from terrestrial ecosystems (and not from photosynthesis by aquatic organisms). As such, it is terrestrial carbon that is buried in inland sediments. This import of terrestrial C explains why inland waters can be both a net source of C and GHG (by returning a proportion of the imported C to the atmosphere) and a C-sink (through burial of another proportion of the terrestrial C).

If global CO<sub>2</sub> uptake would be uniformly distributed over the globe, the region under study is expected to sequester  $-45$  to  $-105$  Tg C yr<sup>-1</sup>. Based on three independent approaches, we estimated the European C-sequestration to amount  $-205 \pm 72$  Tg C yr<sup>-1</sup>. Owing to its large uncertainty, the additional uptake of 100 to 160 Tg C was not statistically significant but was nevertheless seen as an indicator that the European land surface (including inland waters) takes up more C than the global average. Along the same lines of reasoning, the region under consideration represents less than 4 % of global photosynthesis but realizes 8 to 18 % of the global terrestrial C-sink.

If the C-cost for ecosystem management is taken into account, the net uptake of ecosystems was estimated to decrease by 45 % but still indicates substantial C-sequestration. Also, when the balance is extended from CO<sub>2</sub> towards the main GHGs, C-uptake by terrestrial and aquatic ecosystems is compensated for by emissions of GHGs. As such, the European ecosystems are unlikely to contribute to mitigating the effects of climate change.

Until the present, it had appeared impossible to independently estimate temporally resolved GHG balances over Europe for 1991–2000 and 2001–2009 due to the lack of data. For several of the fluxes, all available data needed to be combined into a single and, therefore, temporally undefined estimate. We assigned our estimate to the period 2001–2005 but made use of data from other time periods. Hence, we did not succeed in obtaining high temporal consistency as stated in the objectives of this study; therefore, temporal patterns in the GHG balance are not supported by this data compilation. For the same reason, we could not estimate the European sink for two time periods and can, therefore, not determine whether the sink increased, decreased or remained unchanged. Given the high uncertainty, important changes in the sink strength would be required to result in a statistically significant change.

Obtaining high spatial consistency, another objective of this study, was reasonably well achieved as most data products come with a well-defined spatial extent. However, it remains unclear whether all products could be considered representative for the whole spatial domain as often only subregion(s) of the under study were sampled. These inconsistencies are not reflected in the GHG balances for 2001–2005; for five out of six budget components, a good agreement was found between the flux-based and inventory-based approach. Poor agreement was only observed for the biological product pool.

Good agreement between fluxes, inventories and inversions (Table 2) increases our confidence that the current estimate of the GHG balance is unlikely to be strongly biased. However, due to largely unknown uncertainty of most data products, the uncertainty of both net land to atmosphere CO<sub>2</sub> balance and land C-uptake remains high. Given that both the net land to atmosphere CO<sub>2</sub> balance and the land C-uptake are determined by a few large fluxes (i.e. emissions from fossil burning, change in C-content of forests and product decay), the uncertainty of these key components needs to be formally estimated before efforts could be made to reduce the uncertainty. Reduced uncertainties in combination with the already reasonable accuracy would further increase our confidence in the European GHG balances.

**Supplementary material related to this article is available online at: <http://www.biogeosciences.net/9/3357/2012/bg-9-3357-2012-supplement.pdf>.**

#### Acknowledgements.

- Sebastiaan Luyssaert is funded by ERC Starting Grant 242564.
- Robert Andres was sponsored by US Department of Energy, Office of Science, Biological and Environmental Research (BER) programs and performed at Oak Ridge National Laboratory (ORNL) under US Department of Energy contract DE-AC05-00OR22725.
- David Bastviken was supported by the Swedish Research councils VR and FORMAS and by Linköping University.
- Frederic Chevallier is funded by the European Commission under the EU Seventh Research Framework Programme (grant agreement 212196, COCOS)
- Karl-Heinz Erb is funded by ERC Starting Grant 263522.
- Jens Hartmann and Nils Moosdorf are funded by the German Research Foundation (DFG), Grants EXC117 and HA4472-6/1.
- Annalea Lohila is funded by the EU-project GHG Europe (244122).
- Sylvestre Njakou Djomo is supported by the ERC Advanced Grant 233366.
- Dario Papale was partly supported by the EU projects GeoCarbon and Geoland-2.

- Wouter Peters is funded by NWO VIDI grant 864.08.012.
- Rona Thompson was supported by NitroEurope (SUS-812TDEV-2004-3.I.1.1) (formerly at LSCE, Gif sur Yvette, France, now at Norwegian Institute for Air Research (NILU), Kjeller, Norway).
- Martin Wattenbach was partly funded by the MILIEU project as part of the German Excellency Initiative, GHG-Europe, CC-tame and CarboExtreme.
- Sönke Zaehle is supported by Marie Curie Reintegration Grant 224775.

*Disclaimer.* The views expressed in this paper are those of the authors and do not necessarily reflect the position of the Institutions to which they are affiliated.

Edited by: J. Canadell



The publication of this article is financed by CNRS-INSU.

#### References

- Aydin, M., Verhulst, K. R., Saltzman, E. S., Battle, M. O., Montzka, S. A., Blake, D. R., Tang, Q., and Prather, M. J.: Recent decreases in fossil-fuel emissions of ethane and methane derived from firm air, *Nature*, 476, 198–201, doi:10.1038/nature10352, 2011.
- Baldocchi, D. D.: “Breathing” of the terrestrial biosphere: Lessons learned from a global network of carbon dioxide flux measurement systems, *Aust. J. Bot.*, 56, 1–26, 2008.
- Bellamy, P. H., Loveland, P. J., Bradley, R. I., Lark, R. M., and Kirk, G. J. D.: Carbon losses from all soils across England and Wales 1978–2003, *Nature*, 437, 245–248, 2005.
- Bellassen, V., Viovy, N., Luyssaert, S., le Maire, G., Schelhaas, M. J., and Ciais, P.: Reconstruction and attribution of the carbon sink of European forests between 1950 and 2000, *Global Change Biol.*, 17, 3274–3292, doi:10.1111/j.1365-2486.2011.02476.x, 2011.
- Bousquet, P., Ciais, P., Miller, J. B., Dlugokencky, E. J., Hauglustaine, D. A., Prigent, C., Van der Werf, G. R., Peylin, P., Brunke, E. G., Carouge, C., Langenfelds, R. L., Lathiere, J., Papa, F., Ramonet, M., Schmidt, M., Steele, L. P., Tyler, S. C., and White, J.: Contribution of anthropogenic and natural sources to atmospheric methane variability, *Nature*, 443, 439–443, 2006.
- Bousquet, P., Ringeval, B., Pison, I., Dlugokencky, E. J., Brunke, E.-G., Carouge, C., Chevallier, F., Fortems-Cheiney, A., Frankenberg, C., Hauglustaine, D. A., Krummel, P. B., Langenfelds, R. L., Ramonet, M., Schmidt, M., Steele, L. P., Szopa, S., Yver, C., Viovy, N., and Ciais, P.: Source attribution of the changes in atmospheric methane for 2006–2008, *Atmos. Chem. Phys.*, 11, 3689–3700, doi:10.5194/acp-11-3689-2011, 2011.

- Broquet, G., Chevallier, F., Rayner, P., Aulagnier, C., Pison, I., Ramonet, M., Schmidt, M., Vermeulen, A. T., and Ciais, P.: A european summertime CO<sub>2</sub> biogenic flux inversion at mesoscale from continuous in situ mixing ratio measurements, *J. Geophys. Res.*, 116, D23303, doi:10.1029/2011jd016202, 2011.
- Canadell, J. G., Le Quere, C., Raupach, M. R., Field, C. B., Buitenhuis, E. T., Ciais, P., Conway, T. J., Gillett, N. P., Houghton, R. A., and Marland, G.: Contributions to accelerating atmospheric CO<sub>2</sub> growth from economic activity, carbon intensity, and efficiency of natural sinks, *Proc. Natl. Acad. Sci. USA*, 104, 18866–18870, 2007.
- Canadell, J. G., Ciais, P., Gurney, K., Le Quere, C., Piao, S. L., Raupach, M. R., and Sabine, C. L.: An international effort to quantify regional carbon fluxes, *EOS*, 92, 81–82, 2011.
- Ceschia, E., Beziat, P., Dejoux, J. F., Aubinet, M., Bernhofer, C., Bodson, B., Buchmann, N., Carrara, A., Cellier, P., Di Tommasi, P., Elbers, J. A., Eugster, W., Grunwald, T., Jacobs, C. M. J., Jans, W. W. P., Jones, M., Kutsch, W., Lanigan, G., Magliulo, E., Marloie, O., Moors, E. J., Moureaux, C., Olioso, A., Osborne, B., Sanz, M. J., Saunders, M., Smith, P., Soegaard, H., and Wattenbach, M.: Management effects on net ecosystem carbon and ghg budgets at european crop sites, *Agr. Ecosyst. Environ.*, 139, 363–383, doi:10.1016/j.agee.2010.09.020, 2010.
- Chapin, F. S., Woodwell, G. M., Randerson, J. T., Lovett, G. M., Rastetter, E. B., Baldocchi, D., Clark, D. A., Harmon, M. E., Schimel, D., Valentine, D. W., Wirth, C., Aber, J., Cole, J. J., Gibling, A. E., Goulden, M. L., Harden, J. W., Heimann, M., Howarth, R. W., Matson, P., McGuire, A. D., Melillo, J., Mooney, H. A., Neff, J. C., Houghton, J. T., Pace, M. L., Ryan, M. G., Running, S., Sala, O. E., Schlesinger, R. C., and Schulz, E.-D.: Reconciling carbon-cycle concepts, terminology and methodology, *Ecosystems*, 9, 1041–1050, 2005.
- Chevallier, F., Ciais, P., Conway, T. J., Aalto, T., Anderson, B. E., Bousquet, P., Brunke, E. G., Ciattaglia, L., Esaki, Y., Froehlich, M., Gomez, A., Gomez-Pelaez, A. J., Haszpra, L., Krummel, P. B., Langenfelds, R. L., Leuenberger, M., Machida, T., Maignan, F., Matsueda, H., Morgui, J. A., Mukai, H., Nakazawa, T., Peylin, P., Ramonet, M., Rivier, L., Sawa, Y., Schmidt, M., Steele, L. P., Vay, S. A., Vermeulen, A. T., Wofsy, S., and Worthy, D.: CO<sub>2</sub> surface fluxes at grid point scale estimated from a global 21 year reanalysis of atmospheric measurements, *J. Geophys. Res.*, 115, D21307, doi:10.1029/2010jd013887, 2010.
- Churkina, G., Zaehle, S., Hughes, J., Viovy, N., Chen, Y., Jung, M., Heumann, B. W., Ramankutty, N., Heimann, M., and Jones, C.: Interactions between nitrogen deposition, land cover conversion, and climate change determine the contemporary carbon balance of Europe, *Biogeosciences*, 7, 2749–2764, doi:10.5194/bg-7-2749-2010, 2010.
- Ciais, P., Tans, P. P., Trolier, M., White, J. W. C., and Francey, R. J.: A large northern-hemisphere terrestrial CO<sub>2</sub> sink indicated by the c<sup>13</sup>/c<sup>12</sup> ratio of atmospheric CO<sub>2</sub>, *Science*, 269, 1098–1102, 1995.
- Ciais, P., Reichstein, M., Viovy, N., Granier, A., Ogee, J., Allard, V., Aubinet, M., Buchmann, N., Bernhofer, C., Carrara, A., Chevallier, F., De Noblet, N., Friend, A. D., Friedlingstein, P., Grunwald, T., Heinesch, B., Keronen, P., Knohl, A., Krinner, G., Loustau, D., Manca, G., Matteucci, G., Miglietta, F., Ourcival, J. M., Papale, D., Pilegaard, K., Rambal, S., Seufert, G., Soussana, J. F., Sanz, M. J., Schulze, E. D., Vesala, T., and Valentini, R.: Europe-wide reduction in primary productivity caused by the heat and drought in 2003, *Nature*, 437, 529–533, doi:10.1038/nature03972, 2005.
- Ciais, P., Canadell, J. G., Luysaert, S., Chevallier, F., Shvidenko, A., Poussi, Z., Jonas, M., Peylin, P., King, A. W., Schulze, E. D., Piao, S. L., Rodenbeck, C., Peters, W., and Breon, F. M.: Can we reconcile atmospheric estimates of the northern terrestrial carbon sink with land-based accounting?, *Current Opinion in Environmental Sustainability*, 2, 225–230, doi:10.1016/j.cosust.2010.06.008, 2010a.
- Ciais, P., Gervois, S., Vuichard, N., Piao, S. L., and Viovy, N.: Effects of land use change and management on the european cropland carbon balance, *Global Change Biol.*, 17, 320–338, doi:10.1111/j.1365-2486.2010.02341.x, 2010b.
- Ciais, P., Wattenbach, M., Vuichard, N., Smith, P., Piao, S. L., Don, A., Luysaert, S., Janssens, I. A., Bondeau, A., Dechow, R., Leip, A., Smith, P. C., Beer, C., van der Werf, G. R., Gervois, S., Van Oost, K., Tomelleri, E., Freibauer, A., Schulze, E. D., and Team, C. S.: The european carbon balance. Part 2: Croplands, *Global Change Biol.*, 16, 1409–1428, doi:10.1111/j.1365-2486.2009.02055.x, 2010c.
- Corazza, M., Bergamaschi, P., Vermeulen, A. T., Aalto, T., Haszpra, L., Meinhardt, F., O'Doherty, S., Thompson, R., Moncrieff, J., Popa, E., Steinbacher, M., Jordan, A., Dlugokencky, E., Brühl, C., Krol, M., and Dentener, F.: Inverse modelling of European N<sub>2</sub>O emissions: assimilating observations from different networks, *Atmos. Chem. Phys.*, 11, 2381–2398, doi:10.5194/acp-11-2381-2011, 2011.
- Davidson, E.: The contribution of manure and fertilizer nitrogen to atmospheric nitrous oxide since 1860, *Nat. Geosci.*, 2, 659–662, 2009.
- Dolman, A. J., Shvidenko, A., Schepaschenko, D., Ciais, P., Tchepakova, N., Chen, T., van der Molen, M. K., Beletti Marchesini, L., Maximov, T. C., Maksyutov, S., and Schulze, E.-D.: An estimate of the terrestrial carbon budget of Russia using inventory based, eddy covariance and inversion methods, *Biogeosciences Discuss.*, 9, 6579–6626, doi:10.5194/bgd-9-6579-2012, 2012.
- EFMA: Nitrogen fertiliser consumption in eu-27 countries 2006/07 (agricultural use), European Fertiliser Manufacturer Association (EFMA), Brussels, Belgium, 2007.
- Enting, I. G.: Inverse problems in atmospheric constituent transport, Cambridge University Press, Cambridge, UK, 2002.
- Erb, K.-H., Gingrich, S., Krausmann, F., and Haberl, H.: Industrialization, fossil fuels, and the transformation of land use, *J. Ind. Ecol.*, 12, 686–703, 2008.
- FAO: Faostat forest products and trade, in: FAO, 2008.
- Fortems-Cheiney, A., Chevallier, F., Pison, I., Bousquet, P., Szopa, S., Deeter, M. N., and Clerbaux, C.: Ten years of CO<sub>2</sub> emissions as seen from measurements of pollution in the troposphere (mopitt), *J. Geophys. Res.*, 116, D05304, doi:10.1029/2010JD014416, 2011.
- Frischknecht, R., Jungbluth, N., Althaus, H. J., Bauer, C., Doka, G., Dones, R., Hischier, R., Hellweg, S., Humbert, S., Kollner, T., Loerincik, Y., Margni, M., and Nemecek, T.: Implementation of life cycle impact assessment methods, in: Ecoinvent report No. 3, V2.0, Swiss Centre for Life Cycle Inventory, Dübendorf, Switzerland, 2007.

- Fuu Ming, K., Tyler, S. C., Randerson, J. T., and Blake, D. R.: Reduced methane growth rate explained by decreased northern hemisphere microbial sources, *Nature*, 476, 194–197, doi:10.1038/nature10259, 2011.
- Gervois, S., Ciais, P., de Noblet-Duoudre, N., Brisson, N., Vuichard, N., and Viovy, N.: Carbon and water balance of european croplands throughout the 20th century, *Glob. Biogeochem. Cy.*, 22, Gb2022, doi:10.1029/2007gb003018, 2008.
- Gingrich, S., Erb, K.-H., Krausmann, F., Gaube, V., and Haberl, H.: Long-term dynamics of terrestrial carbon stocks in austria: A comprehensive assessment of the time period from 1830 to 2000, *Reg. Environ. Change*, 7, 37–47, 2007.
- Goidts, E. and Wesemael, M.: Regional assessment of soil organic carbon changes under agriculture in southern belgium (1955–2005), *Geoderma*, 141, 341–354, 2007.
- Harrison, A. F., Taylor, K., Scott, A., Poskitt, J. A. N., Benham, D., Grace, J., Chaplow, J., and Rowland, P.: Potential effects of climate change on doc release from three different soil types on the northern pennines uk: Examination using field manipulation experiments, *Global Change Biol.*, 14, 687–702, doi:10.1111/j.1365-2486.2007.01504.x, 2008a.
- Harrison, R. G., Jones, C. D., and Hughes, J. K.: Competing roles of rising CO<sub>2</sub> and climate change in the contemporary European carbon balance, *Biogeosciences*, 5, 1–10, doi:10.5194/bg-5-1-2008, 2008b.
- Hoerling, M. P., Hurrell, J. W., and Xu, T. Y.: Tropical origins for recent north atlantic climate change, *Science*, 292, 90–92, 2001.
- Hudiburg, T., Law, B. E., Wirth, C., and Luysaert, S.: Regional carbon dioxide implications of forest bioenergy production, *Nature Climate Change*, 1, 419–423, 2011.
- Hurrell, J. W.: Decadal trends in the north-atlantic oscillation - regional temperatures and precipitation, *Science*, 269, 676–679, 1995.
- Janssens, I. A., Freibauer, A., Ciais, P., Smith, P., Nabuurs, G. J., Folberth, G., Schlamadinger, B., Hutjes, R. W. A., Ceulemans, R., Schulze, E. D., Valentini, R., and Dolman, A. J.: Europe's terrestrial biosphere absorbs 7 to 12% of european anthropogenic CO<sub>2</sub> emissions, *Science*, 300, 1538–1542, 2003.
- Joosten, H.: The global peatland CO<sub>2</sub> picture. Peatland status and drainage related emissions in all countries of the world, Greifswald University, Ede, 36, 2010.
- Jung, M., Reichstein, M., and Bondeau, A.: Towards global empirical upscaling of FLUXNET eddy covariance observations: validation of a model tree ensemble approach using a biosphere model, *Biogeosciences*, 6, 2001–2013, doi:10.5194/bg-6-2001-2009, 2009.
- Jung, M., Reichstein, M., Margolis, H. A., Cescatti, A., Richardson, A. D., Arain, M. A., Arneth, A., Bernhofer, C., Bonal, D., Chen, J., Gianelle, D., Gobron, N., Kiely, G., Kutsch, W., Lasslop, G., Law, B. E., Lindroth, A., Merbold, L., Montagnani, L., Moors, E. J., Papale, D., Sottocornola, M., Vaccari, F., and Williams, C. A.: Global patterns of land – atmosphere fluxes of carbon dioxide, latent heat, and sensible heat derived from eddy covariance, satellite, and meteorological observations, *J. Geophys. Res.*, 16, G00J07, doi:10.1029/2010JG001566, 2011.
- Keeling, C. D., Whorf, T. P., Wahlen, M., and van der Plicht, J.: Interannual extremes in the rate of rise of atmospheric carbon dioxide since 1980, *Nature*, 375, 666, doi:10.1038/375666a0, 1995.
- Körner, C.: Slow in, rapid out – carbon flux studies and kyoto targets, *Science*, 300, 1242–1243, 2003.
- Kutsch, W. L., Aubinet, M., Buchmann, N., Smith, P., Osborne, B., Eugster, W., Wattenbach, M., Schrumpf, M., Schulze, E. D., Tomelleri, E., Ceschia, E., Bernhofer, C., Beziat, P., Carrara, A., Di Tommasi, P., Grunwald, T., Jones, M., Magliulo, V., Marloie, O., Moureaux, C., Olioso, A., Sanz, M. J., Saunders, M., Søgaard, H., and Ziegler, W.: The net biome production of full crop rotations in europe, *Agr. Ecosyst. Environ.*, 139, 336–345, 2010.
- Law, B. E., Falge, E., Gu, L., Baldocchi, D. D., Bakwin, P., Berbigier, P., Davis, K., Dolman, A. J., Falk, M., Fuentes, J. D., Goldstein, A., Granier, A., Grelle, A., Hollinger, D., Janssens, I. A., Jarvis, P., Jensen, N. O., Katul, G., Mahli, Y., Matteucci, G., Meyers, T., Monson, R., Munger, W., Oechel, W., Olson, R., Pilegaard, K., Paw, K. T., Thorgeirsson, H., Valentini, R., Verma, S., Vesala, T., Wilson, K., and Wofsy, S.: Environmental controls over carbon dioxide and water vapor exchange of terrestrial vegetation, *Agric. For. Meteorol.*, 113, 97–120, 2002.
- Le Quééré, C., Raupach, M. R., Canadell, J. G., Marland, G., Bopp, L., Ciais, P., Conway, T. J., Doney, S. C., Feely, R. A., Foster, P., Friedlingstein, P., Gurney, K., Houghton, R. A., House, J. I., Huntingford, C., Levy, P. E., Lomas, M. R., Majkut, J., Metz, N., Ometto, J. P., Peters, G. P., Prentice, I. C., Randerson, J. T., Running, S. W., Sarmiento, J. L., Schuster, U., Sitch, S., Takahashi, T., Viovy, N., van der Werf, G. R., and Woodward, F. I.: Trends in the sources and sinks of carbon dioxide, *Nat. Geosci.*, 2, 831–836, 2009.
- Letten, S., van Orshoven, J., van Wesemael, B., Muys, B., and Perin, D.: Soil organic carbon changes in landscape units of belgium between 1960 and 2000 with reference to 1990, *Global Change Biol.*, 11, 2128–2140, 2005.
- Linderholm, H. W., Folland, C. K., and Walther, A.: A multicentury perspective on the summer north atlantic oscillation (snao) and drought in the eastern atlantic region, *J. Quaternary Sci.*, 24, 415–425, doi:10.1002/jqs.1261, 2009.
- Luysaert, S., Inglima, I., Jung, M., Richardson, A. D., Reichstein, M., Papale, D., Piao, S. L., Schulz, E.-D., Wingate, L., Matteucci, G., Aragao, L., Aubinet, M., Beer, C., Bernhofer, C., Black, K. G., Bonal, D., Bonnefond, J.-M., Chambers, J., Ciais, P., Cook, B., Davis, K. J., Dolman, A. J., Gielen, B., Goulden, M., Grace, J., Granier, A., Grelle, A., Griffis, T. J., Grünwald, T., Guidolotti, G., Hanson, P. J., Harding, R., Hollinger, D. Y., Hutya, L. R., Kolari, P., Kruijt, B., Kutsch, W., Lagergren, F., Laurila, T., Law, B. E., Le Maire, G., Lindroth, A., Loustau, D., Malhi, Y., Mateus, J., Migliavacca, M., Misson, L., Montagnani, L., Moncrieff, H., Moors, E., Munger, J. W., Nikinmaa, E., Ollinger, S. V., Pita, G., Rebmann, C., Rouspard, O., Saigusa, N., Sanz, M. J., Seufert, G., Sierra, C., Smith, M.-L., Tang, J., Valentini, A., Vesala, T., and Janssens, I. A.: CO<sub>2</sub>-balance of boreal, temperate and tropical forest derived from a global database, *Global Change Biol.*, 13, 2509–2537, 2007.
- Luysaert, S., Ciais, P., Piao, S. L., Schulze, E. D., Jung, M., Zaehle, S., Schelhaas, M. J., Reichstein, M., Churkina, G., Papale, D., Abril, G., Beer, C., Grace, J., Loustau, D., Matteucci, G., Magnani, F., Nabuurs, G. J., Verbeeck, H., Sulkava, M., van der Werf, G. R., Janssens, I. A., and Team, C.-I. S.: The european carbon balance, Part 3: Forests, *Global Change Biol.*, 16, 1429–1450, doi:10.1111/j.1365-2486.2009.02056.x, 2010.

- Papale, D. and Valentini, A.: A new assessment of european forests carbon exchanges by eddy fluxes and artificial neural network spatialization, *Global Change Biol.*, 9, 525–535, 2003.
- Peters, W., Krol, M. C., van der Werf, G. R., Houweling, S., Jones, C. D., Hughes, J., and Schaefer, K.: Seven years of recent european net terrestrial carbon dioxide exchange constrained by atmospheric observations, *Global Change Biology Bioenergy*, 16, 1317–1337, doi:10.1111/j.1365-2486.2009.02078.x, 2010.
- Peylin, P., Rayner, P. J., Bousquet, P., Carouge, C., Hourdin, F., Heinrich, P., Ciais, P., and AEROCARB contributors: Daily CO<sub>2</sub> flux estimates over Europe from continuous atmospheric measurements: 1, inverse methodology, *Atmos. Chem. Phys.*, 5, 3173–3186, doi:10.5194/acp-5-3173-2005, 2005.
- Ramonet, M., Ciais, P., Aalto, T., Aulagnier, C., Chevallier, F., Cipriano, D., Conway, T. J., Haszpra, L., Kazan, V., Meinhardt, F., Paris, J. D., Schmidt, M., Simmonds, P., Xueref-Remy, I., and Necki, J. N.: A recent build-up of atmospheric CO<sub>2</sub> over Europe. Part 1: Observed signals and possible explanations, *Tellus*, 62, 1–13, doi:10.1111/j.1600-0889.2009.00442.x, 2010.
- Rayner, P. J., Scholze, M., Knorr, W., Kaminski, T., Giering, R., and Widmann, H.: Two decades of terrestrial carbon fluxes from a carbon cycle data assimilation system (ccdas), *Glob. Biogeochem. Cycle.*, 19, GB2026, doi:10.1029/2004GB002254, 2005.
- Reichstein, M., Falge, E., Baldocchi, D., Papale, D., Aubinet, M., Berbigier, P., Bernhofer, C., Buchmann, N., Gilmanov, T., Granier, A., Grunwald, T., Havrankova, K., Ilvesniemi, H., Janous, D., Knohl, A., Laurila, T., Lohila, A., Loustau, D., Matteucci, G., Meyers, T., Miglietta, F., Ourcival, J. M., Pumpanen, J., Rambal, S., Rotenberg, E., Sanz, M., Tenhunen, J., Seufert, G., Vaccari, F., Vesala, T., Yakir, D., and Valentini, R.: On the separation of net ecosystem exchange into assimilation and ecosystem respiration: Review and improved algorithm, *Global Change Biol.*, 11, 1424–1439, 2005.
- Rödenbeck, C., Houweling, S., Gloor, M., and Heimann, M.: CO<sub>2</sub> flux history 1982–2001 inferred from atmospheric data using a global inversion of atmospheric transport, *Atmos. Chem. Phys.*, 3, 1919–1964, doi:10.5194/acp-3-1919-2003, 2003.
- Saarnio, S., Morero, M., Shurpali, N. J., Tuittila, E.-S., Makila, M., and Alm, J.: Annual CO<sub>2</sub> and CH<sub>4</sub> fluxes of pristine boreal mires as a background for the lifecycle analyses of peat energy, *Boreal Environ. Res.*, 12, 101–113, 2007.
- Schulze, E. D., Luyssaert, S., Ciais, P., Freibauer, A., Janssens, I. A., Soussana, J. F., Smith, P., Grace, J., Levin, I., Tiruchittampalam, B., Heimann, M., Dolman, A. J., Valentini, R., Bousquet, P., Peylin, P., Peters, W., Rödenbeck, C., Etiope, G., Vuichard, N., Wattenbach, M., Nabuurs, G. J., Poussi, Z., Nieschulze, J., Gash, J. H., and Team, C.: Importance of methane and nitrous oxide emissions for Europe's terrestrial greenhouse gas balance, *Nat. Geosci.*, 2, 842–850, 2009.
- Schulze, E. D., Ciais, P., Luyssaert, S., Schrumpp, M., Janssens, I. A., Thiruchittampalam, B., Theloke, J., Saurat, M., Bringezu, S., Lelieveld, J., Lohila, A., Rebmann, C., Jung, M., Bastviken, D., Abril, G., Grassi, G., Leip, A., Freibauer, A., Kutsch, W., Don, A., Nieschulze, J., Börner, A., Gash, J. H., and Dolman, A. J.: The European carbon balance. Part 4: Integration of carbon and other trace-gas fluxes, *Global Change Biol.*, 16, 1451–1469, doi:10.1111/j.1365-2486.2010.02215.x, 2010.
- Shvidenko, A., and Nilsson, S.: Dynamics of Russian forests and the carbon budget in 1961–1998: An assessment based on long-term forest inventory data, *Clim. Change*, 55, 5–37, 2002.
- Shvidenko, A. Z., Nilsson, S., Stolbovoi, V. S., Rozhkov, V. A., and Gluck, M.: Aggregated estimation of basic parameters of biological production and the carbon budget of Russian terrestrial ecosystems: 2. Net primary production, *Russ. J. Ecol.*, 32, 71–77, doi:10.1023/A:1009538529069, 2001.
- Soussana, J. F., Loiseau, P., Vuichard, N., Ceschia, E., Balesdent, J., Chevallier, T., and Arrouays, D.: Carbon cycling and sequestration opportunities in temperate grasslands, *Soil Use Manage.*, 20, 219–230, 2004.
- Spiegelhalter, D. J., Best, N. G., Carlin, B. P., and van der Linde, A.: Bayesian measures of model complexity and fit, *J. Roy. Stat. Soc. B*, 64, 583–639, 2002.
- Stephens, B. B., Gurney, K. R., Tans, P. P., Sweeney, C., Peters, W., Bruhwiler, L., Ciais, P., Ramonet, M., Bousquet, P., Nakazawa, T., Aoki, S., Machida, T., Inoue, G., Vinnichenko, N., Lloyd, J., Jordan, A., Heimann, M., Shibistova, O., Langenfelds, R. L., Steele, L. P., Francey, R. J., and Denning, A. S.: Weak northern and strong tropical land carbon uptake from vertical profiles of atmospheric CO<sub>2</sub>, *Science*, 316, 1732–1735, 2007.
- Stott, P. A., Stone, D. A., and Allen, M. R.: Human contribution to the European heatwave of 2003, *Nature*, 432, 610–614, 2004.
- Sulkava, M., Luyssaert, S., Zaehle, S., and Papale, D.: Assessing and improving the representativeness of monitoring networks: The European flux tower network example, *J. Geophys. Res.*, 116, G00J04, doi:10.1029/2010jg001562, 2011.
- Tans, P. P., Fung, I. Y., and Takahashi, T.: Observational constraints on the global atmospheric CO<sub>2</sub> budget, *Science*, 247, 1431–1438, 1990.
- Thompson, R. L., Bousquet, P., Chevallier, F., Dlugokencky, E., Vermeulen, A. T., Aalto, T., Haszpra, L., Meinhardt, F., O'Doherty, S., Moncrieff, J., Poppo, M. E., Steinbacher, M., Jordan, A., Schuck, T., and Brenninkmeijer, C. A. M.: Global and European scale N<sub>2</sub>O emissions estimated using a variational inversion approach, *Nitrogen & Global Change Proceedings*, Edinburgh, 11–14 April 2011, 2011.
- Tupek, B., Zanchi, G., Verkerk, P. J., Churkina, G., Viovy, N., Hughes, J. K., and Lindner, M.: A comparison of alternative modelling approaches to evaluate the European forest carbon fluxes, *Forest Ecol. Manag.*, 260, 241–251, 2010.
- UNFCCC: National greenhouse gas inventory data for the period 1990–2005, United Nations Office, Geneva, Switzerland, 28, 2007.
- UNFCCC: National inventory submissions 2011, available at: [http://unfccc.int/national\\_reports/annex\\_i\\_ghg\\_inventories/national\\_inventories\\_submissions/items/5888.php](http://unfccc.int/national_reports/annex_i_ghg_inventories/national_inventories_submissions/items/5888.php), 2011.
- Welp, L. R., Randerson, J. T., and Liu, H. P.: The sensitivity of carbon fluxes to spring warming and summer drought depends on plant functional type in boreal forest ecosystems, *Agric. For. Meteorol.*, 147, 172–185, 2007.
- Yuan, W. P., Luo, Y. Q., Richardson, A. D., Oren, R., Luyssaert, S., Janssens, I. A., Ceulemans, R., Zhou, X. H., Grunwald, T., Aubinet, M., Berhofer, C., Baldocchi, D. D., Chen, J. Q., Dunn, A. L., Deforest, J. L., Dragoni, D., Goldstein, A. H., Moors, E., Munger, J. W., Monson, R. K., Suyker, A. E., Star, G., Scott, R. L., Tenhunen, J., Verma, S. B., Vesala, T., and Wofsy, S. C.: Latitudinal patterns of magnitude and interannual variability in net

- ecosystem exchange regulated by biological and environmental variables, *Global Change Biol.*, 15, 2905–2920, 2009.
- Zaehle, S., Sitch, S., Prentice, I. C., Liski, J., Cramer, W., Erhard, M., Hickler, T., and Smith, B.: The importance of age-related decline in forest npp for modeling regional carbon balances, *Ecol. Appl.*, 16, 1555–1574, 2006.
- Zaehle, S., Bondeau, A., Carter, T. R., Cramer, W., Erhard, M., Prentice, I. C., Reginster, I., Rounsevell, M. D. A., Sitch, S., Smith, B., Smith, P. C., and Sykes, M.: Projected changes in terrestrial carbon storage in europe under climate and land-use change, 1990–2100, *Ecosystems*, 10, 380–401, 2007.
- Zaehle, S., Friend, A. D., Friedlingstein, P., Dentener, F., Peylin, P., and Schulz, M.: Carbon and nitrogen cycle dynamics in the o-cn land surface model: 2, Role of the nitrogen cycle in the historical terrestrial carbon balance, *Glob. Biogeochem. Cy.*, 24, Gb1006, doi:10.1029/2009gb003522, 2010.
- Zaehle, S., Ciais, P., Friend, A. D., and Prieur, V.: Carbon benefits of anthropogenic reactive nitrogen offset by nitrous oxide emissions, *Nat. Geosci.*, 4, 601–605, doi:10.1038/NNGEO1207, 2011.