

Research Report
UKTRP-85-32

THE FEASIBILITY OF DRAGLINES
FOR
MINE RECLAMATION

by

Mark Anderson
Senior Research Engineer

December 1985

Research Report
UKTRP-85-32

THE FEASIBILITY OF DRAGLINES
FOR
MINE RECLAMATION

by

Mark Anderson
Senior Research Engineer

Kentucky Transportation Research Program
College of Engineering
University of Kentucky
Lexington, Kentucky

The contents of this report reflect the views of the author, who is responsible for the facts and accuracy of the data presented herein. The contents do not necessarily reflect the official views or policies of the University of Kentucky. The report does not constitute a standard, specification, or regulation.

December 1985

The Feasibility of Draglines for Mine Reclamation

Mark Anderson, P. E.
Senior Research Engineer
University of Kentucky
Lexington, Kentucky 40506

Abstract. Draglines are presented in this paper as an alternative for mine reclamation in steep sloping areas. Some abandoned mines in steep sloping areas of Kentucky have unreclaimed slopes which pose safety problems, as well as environmental and aesthetic problems. In addition, many active mines in steep sloping areas of Kentucky have slopes which must be reclaimed in the near future. Current methods of slope reclamation in Kentucky typically involve traditional heavy equipment. The current methods are not cost efficient in some cases, and are not safe in some applications.

The paper includes a history of draglines. Early development is summarized, and major improvements are discussed. Unreclaimed acreage in Kentucky and the mining and reclamation methods traditionally used for strip mines in Kentucky are discussed. The engineering feasibility of draglines is discussed. Bearing capacity and slope stability are presented as factors which influence the engineering feasibility of draglines in steep sloping areas. A presumptive value of bearing capacity for a typical spoil bank is calculated. The factor of safety against slope stability failure is discussed. A reclamation method which minimizes the risk of bearing or slope stability failures is presented. The economic feasibility of dragline reclamation is also presented. The initial cost and production costs of dragline equipment is compared to the initial cost and production costs of other reclamation equipment. In addition, the "Crescent" scraper system is introduced as an alternative to conventional dragline bucket and line systems. A dragline equipped with a "Crescent" scraper system can reclaim very long slopes in steep areas which were previously considered unfeasible for dragline use.

Introduction

The author became interested in strip mine reclamation at the age of ten, when his family moved to a mine scarred area of Floyd County, Kentucky. The author also lived in Johnson County and Magoffin County, Kentucky, and saw first hand the damage that unreclaimed strip mines caused. This paper is presented at this time because the author believes that many otherwise well informed professionals in the engineering and mining industries do

not realize the potential of the dragline for the reclamation of strip mines in eastern Kentucky, and in other locales, such as the Rocky Mountain mining areas. The author recognizes the value of traditional techniques and equipment, but feels that consideration should be given to the dragline as a reclamation tool. This paper presents the small walking dragline and the crawler-mounted dragline as equipment which can be used successfully and economically for reclamation in steep sloping areas.

History of the Dragline¹

The need for efficient excavation techniques grew dramatically in the early 1900's. Coal mining expanded rapidly as power was needed to supply homes and new industries. Dams and irrigation projects were constructed to insure adequate water supplies. Foundation and basement excavation was necessary for new factories and buildings. Excavator manufacturers at the turn of the century produced equipment which moved billions of tons of earth. Although the equipment was primitive by today's standards, it met the challenge of the times, and laid the groundwork for the development of modern excavators.

The first dragline was patented by Ralph R. Osgood in 1880. The Osgood Dredge Company advertised the machine as the "Number 15 Steam Shovel to Work Backwards." Prior to the development of this device, all power excavators dug away from themselves. This meant that for all but the smallest trenches, some type of bridge was required for the machine as it moved across the excavation. The Osgood dragline allowed a channel to be dug without bridging the excavation, as the machine stayed on the solid ground above the cut. However, the Osgood dragline had numerous problems which limited its commercial success. The device was mounted on a modified dredge designed to be skidded over the ground. Steam jets lubricated the ground behind the rig, but movement was still very difficult. The early drag buckets were made of hardwoods and lacked digging teeth. In addition, the initial design required separate leads for digging, hoisting, and dumping, which made it difficult to maneuver the bucket and to regulate the cutting depth.

Draglines first became a commercial success in the early 1900's, after some basic design improvements. Boom design was improved and steel buckets were introduced. Skid rigs were replaced with track and roller mounts. A major improvement came in 1912 with the introduction of the crawler-mounted dragline by the Bucyrus Company. However, even with these design improvements, dragline use was limited in scope. The traditional track or skid mounted draglines could not maneuver in close work and the crawler-mounted draglines could work only in areas with very firm soil support.

The biggest breakthrough in dragline design came in 1913 when Oscar Martinson invented the Martinson Tractor, which came to be known as "the walking device." The "walking" motion was produced by a pair of pontoon shoes driven by a rotating eccentric cam system. As the cam rotated, the shoes lifted the frame and moved it forward. This motion could be manipulated to move the dragline forward, backward, or to effect turns in a tight radius. When working, the dragline rested on a circular plate of large area, to reduce the bearing

pressure. The walking dragline quickly became the most popular excavating tool of the era.

In the 1920's, Monighan draglines using the Martinson Tractor were used extensively for reclamation projects, as the United States Reclamation Service utilized dozens of the machines. Emergency reclamation was effected using Monighan draglines following the 1927 Mississippi River floods.

In the 1930's, the walking dragline became a force in the strip mining of anthracite coal. By 1937, the walking dragline was stripping bituminous in the midwestern states, including Kentucky. In the 1940's and 1950's, huge stripping shovels replaced draglines as the primary strip mine excavator. But in the 1960's, draglines with increased size and power were again recognized as major excavating tools. In 1963, a Bucyrus-Erie 1450-W dragline was obtained by the Peabody Coal Company for strip mining at the Paradise Mine. This dragline had a 250-foot boom and 60-cubic yard bucket.

In the 1980's, walking draglines of all sizes are being produced. These include the immense draglines used primarily for area strip mining, medium sized draglines used for a variety of excavation purposes, and small draglines which are particularly useful for reclamation. A small crawler-mounted dragline is shown in Figure 1.

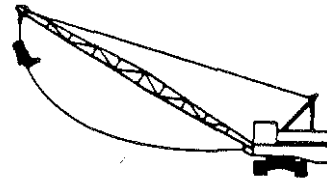

Figure 1. Crawler-mounted dragline.

Unreclaimed Acreage in Kentucky

The United States Department of the Interior has estimated that there is over one million acres in Kentucky which overlay strippable coal reserves.² A large percentage of the coal mined in Kentucky comes from the steep sloping areas of eastern Kentucky. The strip mines in eastern Kentucky are often located in remote areas on land which has little value after the coal is removed. The very low value of reclaimed acreage in these areas have traditionally provided little or no economic justification to proceed with a reclamation effort. As a result, about one hundred thousand acres of stripped land were left unreclaimed in Kentucky during the years from 1930-1971.³ Recent legislation which requires reclamation of active mines and legislation providing for reclamation of abandoned mines has created a new emphasis on reclamation techniques.

Shoot-and-Shove Mining

Reclamation of abandoned mines in eastern Kentucky is complicated by the methods used in the original stripping. Since reclamation was not anticipated, the fastest method of stripping was used. This method is known as the block-cut method of strip mining.⁴ The common and more descriptive name for this method is "shoot-and-shove". Figure 2(a) shows the block-cut method of mining for a typical eastern Kentucky strip mine. A typical overburden template is shown, with shale and sandy shale directly overlying the coal seam. Further up the template, higher quality shaly sandstone and sandstone are found. The expanded view shows a simplified sketch of the mining method. The bulk area labeled "A" is first "shot-and-shoved" over the slope, followed in order by other bulk areas. A close examination reveals that the initial bulk areas have a much higher percentage

of lower quality materials. This creates an underlying layer of very low quality in the resulting spoil bank. This phenomenon is illustrated in Figure 2(b). The disturbed shale, when routinely exposed to water, will weather and develop soil-like qualities, with a large drop in shear strength. This weathering process often causes long term stability problems in spoil banks with high short term stability. Current mining methods favor the modified block-cut method. This method utilizes as fill areas those portions of the bench where coal removal has been completed. In this way, the bench is incrementally filled and only a very small spoil bank is formed on the outslope.

Traditional Reclamation Techniques

Traditional reclamation efforts in Kentucky use the method of terracing with such equipment as bulldozers, graders,

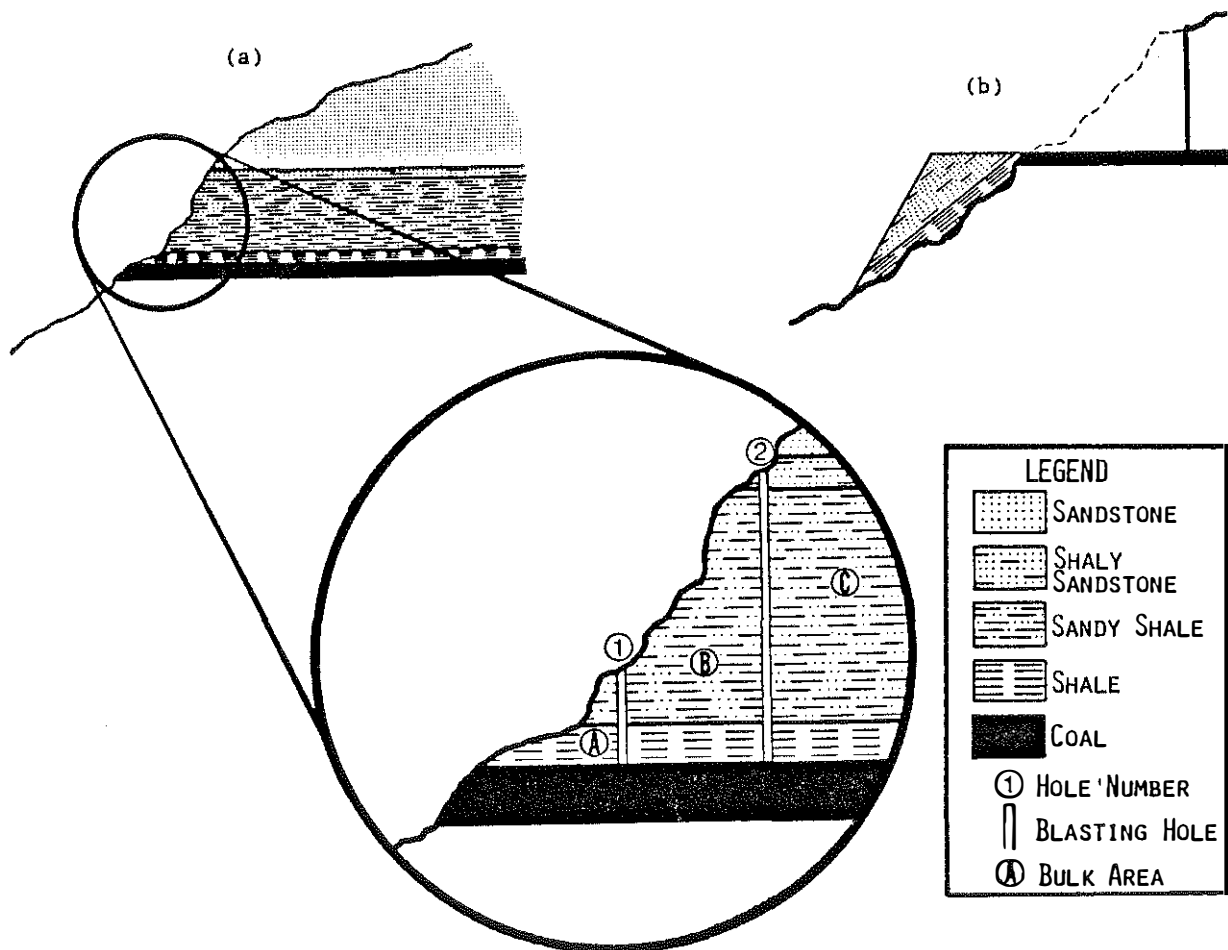

Figure 2. (a) Sketch of a typical eastern Kentucky coal seam with overburden. The expanded view illustrates the block-cut mining method ("shoot-and-shove").

(b) Sketch of the spoil pile which results from block-cut mining. Note the underlying layer of low quality spoil.

end-loaders, and pan scrapers. This method is often the preferred method when the reclamation effort is directed toward "improving" the acreage. In some cases, the terraces are utilized for farming or building in previously unusable areas. However, recent legislation has required that in many cases the land be returned to its approximate original contours. In steep sloping areas, this often creates problems for traditional equipment. The author has witnessed reclamation practices which were not cost-efficient and were, at times, dangerous. An example of a dangerous practice witnessed by the author is the finishing of a slope by pulling a grader up the slope by a cable attached to a bulldozer. The irony of this very dangerous practice is that this combination is a "home-made" dragline, but with an extremely heavy bucket. In all cases, traditional techniques require a large percentage of work be performed with heavy equipment located on the spoil bank. This can cause bearing capacity and slope stability problems which can halt or slow the reclamation effort.

Bearing Capacity in Reclamation

Bearing capacity should be considered in any analysis of feasibility of equipment to be used on soil or soil-like material. Figure 3(a) illustrates a general bearing capacity failure, with lateral and vertical soil displacement. Figure 3(b) illustrates the reduced bearing capacity for a load near the crest of a slope. The dashed line indicates the resistance plane for bearing capacity failure. The shaded area shows that some of the usual plane of resistance does not exist. The reduction factor increases as the load gets closer to the crest of the slope. Bearing failures in slope reclamation rarely are catastrophic. However, these failures can cause work stoppages and slowdowns which can be economically damaging. Draglines have two major advantages when bearing capacity is considered. First, draglines have the advantage of being able to work well back from the crest of the slope. Often the dragline may work completely on parent material, where bearing is not usually critical. In addition, walking draglines have very low bearing pressures. Typical ground pressures for small walking draglines vary from 800 to 1,500 pounds per square foot. Bearing pressures of walking draglines are far lower than for any of the traditional heavy equipment previously mentioned. Bearing capacity values of 1,500 pounds per square foot can be generated by all but the weakest soils.⁵

Presumptive bearing capacity values may be calculated for a spoil bank if certain assumptions are made. Drnevich, et al, proposed presumptive shear strength parameters of cohesion and angle of internal friction of 200 pounds per square foot and 30 degrees, respectively, for mine spoils.⁶ Using these values, the typical ultimate bearing capacity of a spoil bank can be calculated by the

modified Terzaghi equation.⁷ Additional assumptions for this calculation include a unit weight of soil of 125 pounds per cubic foot, a square load of ten feet, no embedment, and location of the load at the crest of the slope. The bearing capacity can be calculated as follows:

$$\begin{aligned} \text{Bearing Capacity} &= (CF_c)(C)(N_c') + (B/2)(CF_\gamma)(\gamma_t)(N_\gamma) \\ &= (1.25)(200)(26.80) \\ &\quad + (10/2)(0.90)(125)(5.5) \\ &= 9,800 \text{ pounds per square foot} \end{aligned}$$

where : CF_c, CF_γ = correction factors based on load geometry
 C = cohesion
 N_c' = bearing capacity factor for cohesion (prime indicates correction for slope)
 B = load width
 γ_t = total unit weight of soil
 N_γ = bearing capacity factor for unit weight

The value calculated above represents the ultimate bearing capacity of a typical spoil bank. The allowable value for bearing capacity would include a safety factor. For a factor of safety of three (a typical value), the allowable bearing pressure for a typical spoil bank would be 3,300 pounds per square foot. The typical allowable bearing pressure is well above the necessary value for small walking draglines. The value calculated above must be considered a presumptive value, as bearing capacity of spoil banks is site specific. Crawler-mounted draglines have static bearing pressures which are typically less than most conventional heavy equipment, but of the same order of magnitude. However, the ability of the dragline to work from the stronger parent material reduces the influence of bearing capacity on the feasibility of dragline reclamation at most eastern Kentucky strip mines.

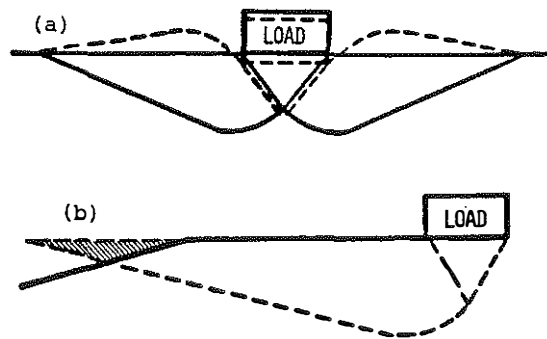

Figure 3. (a) General shear failure. Dashed lines show soil displacement.
 (b) Reduced bearing capacity due to a slope. Dashed lines show resistance plane. Shaded area shows reduced resistance plane.

Slope Stability in Reclamation

Slope stability is the single most important factor in the engineering feasibility of any reclamation effort in a steep sloping area. Figure 4 illustrates the two modes for slope failure. Figure 4(a) shows a circular failure surface, which is usually indicative of a fairly homogeneous slope. Figure 4(b) shows a plane failure (more commonly known as a sliding wedge failure).

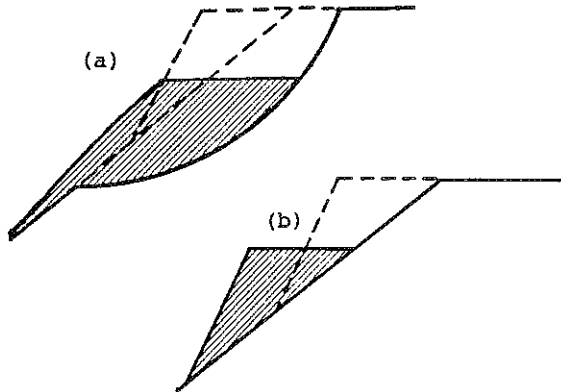

Figure 4. (a) Circular failure.
(b) Plane failure.

Plane failure is generally associated with a plane of weakness (low shear strength) at which sliding can occur. In a plane failure, the soil wedge will continue to slide until resisted. Sliding wedge failure is the most common mode of failure for spoil banks which have been created by the block-cut mining method. As previously discussed, the spoil bank is underlain by low quality spoil material which weathers into a soil-like layer of low shear strength. In addition, most outcrops were covered with vegetation, or grubbing material, at the time of the stripping. This material tends to improve the short term stability, but may act as a lubricant as the vegetable matter decomposes. To further reduce the stability, the spoil bank tends to hold water, often leading to high excess pore pressures. Often, an abandoned mine spoil bank will show signs of impending failure, as in Figure 5. Tension cracks at the crest of the slope of the parent material indicate impending catastrophic failure.

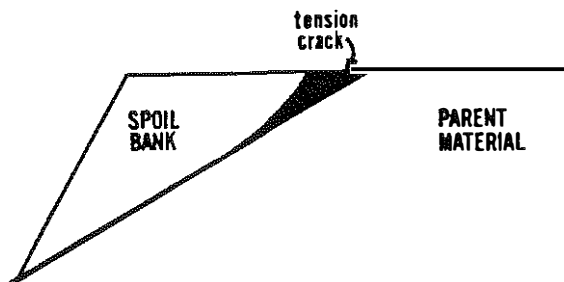

Figure 5. Impending catastrophic failure.

Putting heavy equipment on a spoil bank such as the one shown in Figure 5 adds to the load and increases the chances of a life-threatening confrontation. A full discussion of slope stability is beyond the scope of this paper. However, for clarity, a short discussion of the factor of safety for plane failure is included. The factor of safety is the ratio of the resisting forces to the driving forces. Figure 6 shows the terms used to calculate the factor of safety for plane failure. The equation for plane failure is:

$$\text{Factor of Safety} = \frac{\Sigma F_r}{\Sigma F_d}$$

where:

$$\Sigma F_r = \text{sum of resisting forces} \\ = W_f C \sin \beta / \sin(\beta - \alpha) + (1 - r_u) W \cos \alpha \tan \phi$$

$$\Sigma F_d = \text{sum of driving forces} \\ = W \sin \alpha$$

- W_f = width of spoil bank
- C = cohesion
- β = outslope angle of spoil bank
- α = outslope angle of parent slope
- W = weight of spoil bank
- ϕ = angle of internal friction
- r_u = pore pressure ratio

From inspection of the above equation, it can be seen that an additional load on the spoil bank reduces the factor of safety against plane failure. However, additional loading on the parent material does not reduce the factor of safety against plane failure. This emphasizes the advantage of dragline use for slope stability.

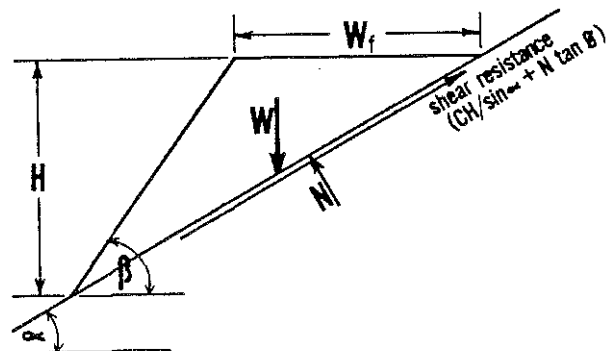

Figure 6. Parameters for calculation of factor of safety.

Proper Dragline Use in Reclamation

Figure 7 illustrates two schemes utilizing a dragline to reclaim a spoil bank. Figure 7(a) shows the improper method. The dragline is working from the spoil bank, risking bearing and stability problems. In addition, inspection of the bulk areas removed reveals that the resistance plane is reduced, with a small reduction in driving force. Catastrophic slope failure could result. Figure 7(b)

shows the proper method for reclaiming a spoil bank with a dragline. The dragline is located on the stronger parent material. Inspection of the bulk areas removed shows that the driving forces are reduced with no reduction in the resistance plane. The slope becomes more stable as material is removed.

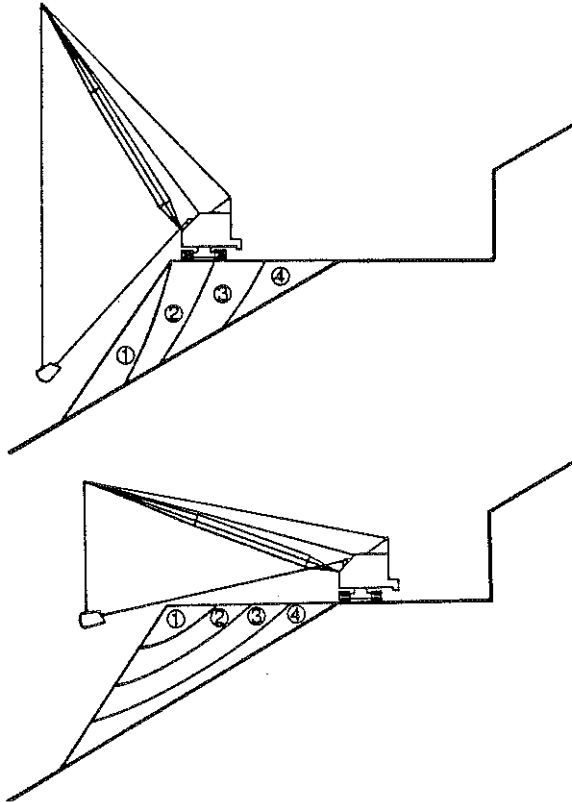

Figure 7. (a) Improper Dragline use. Dragline works on spoil bank and stability is reduced as spoil is moved.
 (b) Proper dragline use. Dragline works on parent material and stability is increased as spoil is moved.

Economics of Draglines in Reclamation

One of the reasons that draglines have not been used extensively for slope reclamation in Kentucky is the high initial cost. Table 1 lists approximate costs for draglines and conventional equipment used in reclamation.

Other costs which may be considered are indirect costs (interest, taxes, insurance, and depreciation) and direct costs (operation and maintenance). Annual indirect costs may be estimated as $(N+1)/2N$ times the capital cost.⁸ Depreciation is usually computed by the straight-line method. Most draglines have

actual lives which outlast their economic lives. Maintenance costs for draglines, as with most heavy equipment, start out low and gradually increase for the life of the unit. In addition, teardown and erection costs must be included if the dragline is to be moved any great distance. Operating costs depend on labor costs, fuel costs, and production rates. Direct comparisons of production rates of draglines and conventional equipment for spoil reclamation are not available. However, the high production rates of draglines are well documented.⁹ Manufacturers specifications of production rates for conventional equipment rarely reflect grades of over 10%, making objective comparisons almost impossible. However, subjective comparisons can be made. A compilation of reclamation costs furnished by Kentucky indicated significant differences in the cost of backfilling and grading for two different types of reclamation.¹⁰ The reported maximum cost for terracing was \$185 per acre. The reported maximum cost for return to approximate original contour was \$1,200 per acre. It is obvious that production rates for conventional equipment drop substantially when return to approximate original contour is required. Manufacturers data indicate that production rates for bulldozers may drop by 50% for a 30% grade.¹¹ Similar drops are anticipated for other heavy equipment. The use of draglines for return to approximate original contour has the advantage of reclaiming and finishing the slope in one operation. The author believes that the cost per acre would be reduced with the use of draglines for spoil reclamation.

Table 1. Capital Costs of Equipment

Description of Equipment	Example of Equipment	Approximate Capital Cost *
Walking Dragline	Bucyrus-Erie 380W	\$ 3,000,000
Crawler-Mounted Dragline	Bucyrus-Erie 88B	\$ 800,000
Bulldozer	Caterpillar D10	\$ 550,000
Pan-Scraper	Caterpillar 657.	\$ 500,000
End-Loader	Caterpillar 992	\$ 500,000
Grader	Caterpillar 16G	\$ 200,000

* All prices are approximate. Actual prices depend on the model, options, location, and market changes.

Modified Dragline Equipment

One argument frequently used against draglines is that they cannot reclaim very

long slopes. This was once a valid complaint. However, the "Crescent" scraper system, developed by Sauerman Bros., Inc., allows reclamation of slopes of almost any length. Figure 8 shows the "Crescent" scraper system. Modifications needed to install the "Crescent" system include the addition of a small tower under the dragline boom, installation of the scraper bucket, and use of a piece of heavy equipment as an anchor. Use of this system can actually speed production. The scraping motion requires no vertical lifting, allowing bucket capacities of up to 150% of the rated capacity. In addition, the open back design of the scraper allows for automatic dumping as the scraper nears the tower. Lateral movement is not hindered, as the tower can be lifted by the boom and moved in unison with the anchoring equipment.

Conclusions

It is the author's conclusion that small draglines could be used to economically reclaim active and abandoned strip mines in eastern Kentucky or any steep sloping area. The author does not believe that draglines could or should be used in every reclamation effort, but that draglines represent an alternative which should be considered. In addition, the author concludes that the combination of a

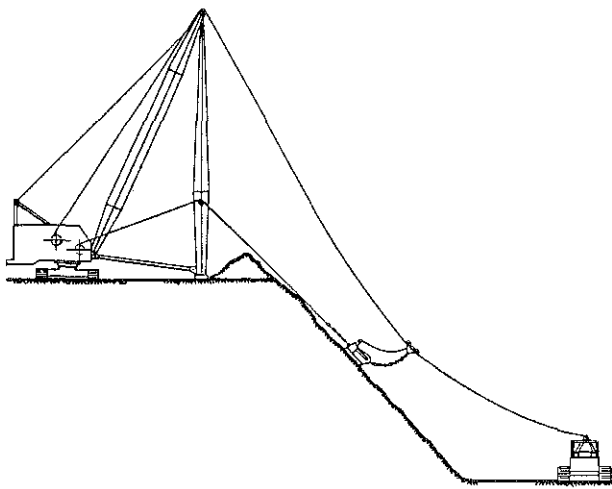

Figure 8. Use of a "Crescent" scraper system to reclaim a long slope. Note that no vertical lifting is required.

dragline with a "Crescent" scraper system can be a powerful tool for reclamation of long slopes.

References

1. "The Big Step," Bucyrus-Erie Publication Number 2013, Bucyrus-Erie Company, South Milwaukee, Wisconsin, 1980.
2. Committee on Soil as a Resource in Relation to Surface Mining for Coal, Surface Mining: Soil, Coal, and Society, National Research Council, National Academy Press, Washington, D.C., 1981.
3. J. Paone, J. L. Morning, and L. Giorgetti, "Land Utilization and Reclamation in the Mining Industry, 1930-1971," Bureau of Mines Information Circular 8642, United States Government Printing Office, Washington, D.C., June 1974.
4. D. R. Maneval, "Coal Mining vs. Environment," Appalachia, Volume 5, Number 4, February-March 1972.
5. J. E. Bowles, Foundation Analysis and Design, McGraw-Hill, New York, 1977, pp. 140.
6. V. P. Drnevich, et al, "Geotechnical Properties of Surface Mine Spoils," Proceedings, Seventh Ohio River Valley Soils Seminar, Lexington, Kentucky, 1976.
7. K. Terzaghi, Theoretical Soil Mechanics, John Wiley and Sons, New York, 1943.
8. A. B. Cummins and I. A. Given, SME Mining Engineering Handbook, AIMMPE, Port City Press, Baltimore, Maryland, 1973.
9. R. K. Singhal, "Excavation and Transportation in Surface Coal Mining - The Recent Past and Near Future," Proceedings, Symposium on Surface Mining, Hydrology, Sedimentology, and Reclamation, University of Kentucky, Lexington, Kentucky, 1984.
10. W. S. Doyle, Strip Mining of Coal - Environmental Solutions, Noyes Data Corporation, Park Ridge, New Jersey, 1976.
11. "Champions by the Yard," Fiat-Allis Publication Number CM-1846, Fiat-Allis, Deerfield, Illinois, 1979.

