

## The Function of the Legs in the Free Walking Stick Insect, *Carausius morosus* \*

H. Cruse

Fachbereich Biologie der Universität, Pfaffenbergstraße, D-6750 Kaiserslautern,  
Federal Republic of Germany

Received July 10, 1976

**Summary.** 1. The function of the legs of a free walking mature stick insect (*Carausius morosus*) is investigated in four different walking situations: walks on a horizontal path, walks on a horizontal plane, walks on a horizontal beam with the body hanging from the beam and walks up a vertical path.

2. The geometrical data, which are necessary to describe the movement of the legs, are determined (Tables 1, 2, 3, 4; Figs. 2, 3, 4, 5).

3. The forces, by which the leg of a free walking animal acts on the walking surface, are measured (Table 5). Typical results are shown in Figures 6, 7, 8, 9 for each walking situation. From these forces and the known geometrical relationships the torques, which are produced by the antagonistic muscle systems at each leg joint, can be calculated (Fig. 10). Those torques calculated for different typical leg positions are shown in Table 6, 7, 8, 9 for each walking situation.

4. The results show that many things change depending upon the particular walking situation: the angular range in which the leg is moved (Table 2, Fig. 4), the activation and the kind of predominance of the antagonistic muscles (Table 6, 7, 8, 9), and especially the function of the single legs. Additionally, when looking at the direction of movement of a limb one cannot say which of the antagonistic muscles is predominating. Sometimes just the muscle opposite to the actual movement predominates (Table 7).

5. For two walking situations the function of the legs can be demonstrated in a simple way. In a walk on the horizontal plane: the forelegs mainly have feeler function, the middlelegs have only supporting function, while the hindlegs have supporting as well as propulsive function. In a walk with the body hanging from the horizontal beam: forelegs and hindlegs are used mainly to support the body, while the middlelegs additionally provide the propulsive forces.

6. In walking up the vertical path all legs provide support and propulsive forces. When walking on the horizontal path fore- and middlelegs on the

\* Supported by the Deutsche Forschungsgemeinschaft

one hand and hindlegs on the other form the static construction of a three centered arch (Fig. 11). In the same way when the insect walks hanging from the horizontal beam, a hanging three centered arch is assumed. The importance of this construction is discussed.

### A. Introduction

A considerable number of authors has dealt with investigations about the walking movements of insects. It is the aim of such investigations, to find out the structure of those neuronal mechanisms, that control and coordinate the different leg movements in the walking insect. Essentially two different methods have been used in these investigations up to now: the movements of the different legs have been recorded (usually filmed) and then evaluated (e.g. Bässler, 1972; Burns, 1973; Delcomyn and Usherwood, 1973; Graham, 1972; Hughes, 1952, 1957, Wendler, 1964). By this method you get information about the way in which the different legs work together. But it has the disadvantage, that you cannot discriminate between active and passive movements of the leg. (An active movement arises from active contraction of the responsible muscle. A passive movement of a leg can arise, when the tarsus of that leg is fixed to the ground and a relative movement between the body and the ground is produced e.g. by gravity or by active movements of the other legs). This disadvantage can be circumvented by a second method, in which the electrical activity of these muscles or their motoneurons is recorded in fixed or in free walking animals (e.g. Burns, 1973; Burrows, 1973; Delcomyn and Usherwood, 1973; Pearson and Iles, 1973). In spite of many successful applications of this method it possesses certain disadvantages. Up to now for technical reasons nobody has recorded electrical potentials from all muscles of one leg at the same time. Therefore up to now we have had no information about the function of the whole leg of the walking insect from electrophysiological investigations.

This information, however, can be obtained by the method used in the present paper. This method consists in measuring those forces, by which a single leg of the free walking insect acts upon the ground. From such measurements it is possible to reconstruct exactly the forces produced by the different pairs of antagonistic muscles of that leg. Besides a pure description of the coordination of the different systems of antagonistic muscles the method used here also offers the possibility of understanding the mechanical function of single legs in the free walking insect. One disadvantage is, that by this method the forces produced by the different leg muscles can only be measured in that part of the movement during which the leg touches the ground (retraction). The forces acting when the tarsus is moving forward (protraction) cannot be calculated by the method described in this paper but in principle they might be reconstructed from the film record.

### B. Method

The experiments have been done with adult female stick insects (*Carausius morosus*, Phasmids). When studying leg movements, these insects are preferred because of their relatively long legs and their rather slow movements compared to insects like the cockroach (at the highest speed

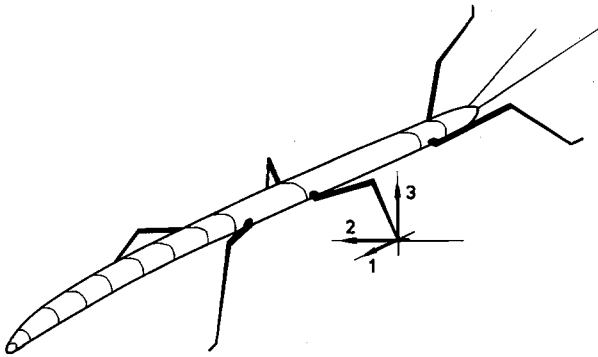

Fig. 1. The three spatial components of forces, measured in a free walking animal

there are about 2 to 3 steps per s). The animals have been tested in several walking situations: a) walk on a horizontal path of a breadth of 30 mm, b) walk on a horizontal plane, c) walk on a horizontal beam (breadth 10 mm) with the body hanging from the beam, and d) walk up a vertical path (breadth 30 mm). The forces by which the legs act upon the walking surface are measured in the following way: In the first walking situation (a) similar to the others a small piece of the margin of the walking path (5 mm broad, 8 mm long) was cut out and then fixed to a force meter, which consists of strain gauges (Hellige SG-4 series). The animal is allowed to walk over the path. If by chance the animal then touches the small platform fixed to the force meter, the force can be measured.

The force meter was oriented in three possible directions and a set of experiments was performed for each orientation of the detector. Thus the component of the force in each direction is measured separately. These directions form a coordinate system fixed relative to the body of the insect and are labelled in the following way: (1) means the component of force, which is parallel to the longitudinal axis of the body and is positive in the posterior direction; (2) means the component of force, which is parallel to the transverse axis of the body and therefore perpendicular to the longitudinal and to the vertical axis of the body and is positive when pointing to the body; (3) means that component, which is parallel to the vertical axis of the body and is positive in the dorsal direction. The coordinate system for the right middle leg is shown in Figure 1. The arrows show the direction in which the force is positive. This means, that because of the weight of the insect body component (3) will mainly be negative when the insect walks on the horizontal plane, and that it mainly will be positive, when the insect walks hanging from the horizontal beam.

In the walking situations (c) (hanging from the beam) and (d) (walking up the vertical path) the force meters were mounted as described earlier at the margin, however in situation (b) (walking on the horizontal plane) the force meter is fixed to a small platform (18 mm long, 4 mm broad), which is mounted in the middle of the walking plane. The resonance frequencies of the force meters depend on the kind of platform used and lie between 25 Hz and 80 Hz. The maximum displacement of the platform when stepped on is less than 1 mm.

The signals from the force meters were amplified and then recorded by a pen-recorder (Hellige He 16 or He 17), which has a corner frequency of about 100 Hz. In one series of experiments the signals were recorded by dual beam storage oscilloscope (Section D.5.). The forces were calibrated in Newton ( $1 \text{ mN} \approx 100 \text{ mp}$ ). When reading off the quantitative values of the forces from the recorder, one has to take into account, that the measurements are limited to an accuracy of about 0.2 mN ( $\approx 20 \text{ mp}$ ). In some experiments, when the insects walk on the horizontal path, two of the force meters were mounted one after the other. Thereby the probability of touching a force meter is higher, and sometimes the forces developed by two different legs can be measured at the same time when both legs stand on different force meters. In some experiments, when walking up the vertical path, a forcemeter constructed by the author was used, in which the three different spatial components of the force can be measured simultaneously. This force meter consists of six strain gauges and an electronic unit, which directly computes the necessary corrections.

To be able to correlate the measured force change with the time course of the movement of the corresponding leg, in separate experiments the animals were filmed from above in the different walking situations (S-8 camera, 18 frames/s). From these films by single frame analysis the anterior and the posterior extreme positions of the tarsus of each leg were determined.

### C. The Geometrical Relationships

From the measured forces acting upon the ground the values of the torques acting at each joint can be calculated. These reaction torques are balanced by the action of the different pairs of antagonistic muscles that control the position of each joint in the leg. To perform this calculation, the geometrical relationship of the leg parts, especially the position of the axis of rotation of the different joints must be measured. The spatial position of the axes of rotation has been investigated by aid of a stereomicroscope in dead and alive animals as well as by evaluation of films of free walking animals. The accuracy of the values of the angles measured with this methods is about  $\pm 10^\circ$ . The tarsus is considered to be attached to the ground and acts as a fixed point about which the tibia is free to rotate in any direction. The femur-tibia joint is a pure hinge joint. Its axis of rotation stands perpendicular to the plane formed by the longitudinal axes of the femur and tibia. The coxa-trochanter joint is also a pure hinge, the axis of rotation of which in all legs is perpendicular to the femur-tibia-plane within the accuracy of measurement, and therefore is parallel to the axis of rotation of the femur-tibia joint. This "femur-tibia-plane" is well suited to describe both the above mentioned joints and is used to define one of the rotational axes of the more complex coxa-thorax articulation. The dorsal rim of the coxa is attached to the thorax at one point which has the properties of a ball joint. The ventral part of the rim is attached to one end of a strut (trochantin) and this strut runs in the plane of the soft cuticle until it reaches the rigid body wall. For walking movements the trochantin strut remains in approximately the same position and its distal end defines the lower joint of the coxa-thorax articulation. However, the strut permits the ventral rim of the coxa to be moved towards or away from the body about an axis passing through the dorsal ball joint parallel to the body axis. Such yaw movements of the coxa cause slight pitching of the semi-vertical rotation axis (Graham, in preparation).

The range of movement about this semi-vertical axis, which is used in walking movements, is  $120\text{--}150^\circ$ , while the range of movement about the horizontal axis (parallel to the longitudinal axis of the body) is  $20\text{--}50^\circ$ . In order to describe the movements of the coxa-thorax articulation, it can be considered to be represented by two orthogonal hinge joints. The position of the axis of rotation of the first hinge, the semi-vertical axis, is defined as intersection of two reference planes, and the orientation of this axis can be obtained in the following way. The tarsus of the leg under examination is moved along the body axis until the femur-tibia-plane is perpendicular to the horizontal plane. This defines a plane which contains the coxa-thorax semi-vertical axis. These planes are shown schematically for all three legs as dotted planes in Figure 2. Here the animal is standing in the same position as in Figure 1. The projection of the semi-vertical

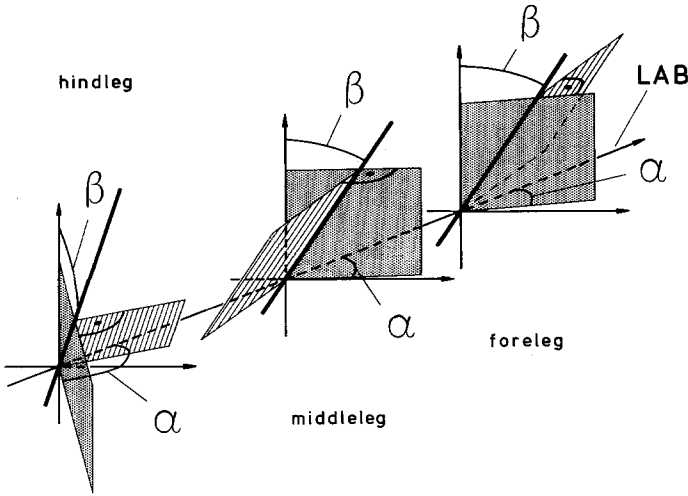

**Fig. 2.** Spatial presentation of the axis of rotation of the coxa-thorax joints in free walking animals (shown for the legs of the right side of the body). *LAB* is the longitudinal axis of the body. (See also Table 1)

**Table 1.** The angles  $\alpha$  and  $\beta$ , describing the spatial position of the axis of rotation of the coxa-thorax joints of a free walking insect. The accuracy of measurement is about  $\pm 10^\circ$ . (See also Fig. 2)

	$\alpha$	$\beta$
Foreleg	$75^\circ$	$40^\circ$
Middleleg	$85^\circ$	$40^\circ$
Hindleg	$135^\circ$	$50^\circ$

axis of rotation onto the horizontal plane forms with the longitudinal axis of the body (*LAB*, signed positive in anterior direction) the angle  $\alpha$  (Fig. 2). The second reference plane is perpendicular to the first and defines the angle  $\beta$  for the semi-vertical axis. To measure the angle  $\beta$  the tarsus is moved along the body axis until the femur-tibia-plane is orthogonal to the first reference plane. The angle between this plane shown as striped planes in Figure 2 and the vertical defines  $\beta$  for each leg. The measured values of the angles  $\alpha$  and  $\beta$  are shown in Table 1 for fore-, middle- and hindlegs.

As mentioned above, the coxa-thorax joint can also be rotated about a horizontal axis. In Figure 3 the extreme positions of the coxa and the trochantro-femur of each of the three legs are shown. These values are measured, when the femur-tibia-plane of the corresponding leg is perpendicular to the horizontal plane (Fig. 2, dotted planes). All angles are given relative to the horizontal line. The axes showing the position of the coxa and the femur are arbitrarily chosen lines only in order to be able to describe the position of coxa and femur.

The angle describing the position of the coxa in free walking animals or those standing on a horizontal plane are in the fore- and middleleg between  $30^\circ$  and  $40^\circ$  and in the hindleg between  $20^\circ$  and  $30^\circ$ . These values show that the coxae usually are positioned in the middle of their possible range. For this position the values of the angles  $\alpha$  and  $\beta$  describing the position of

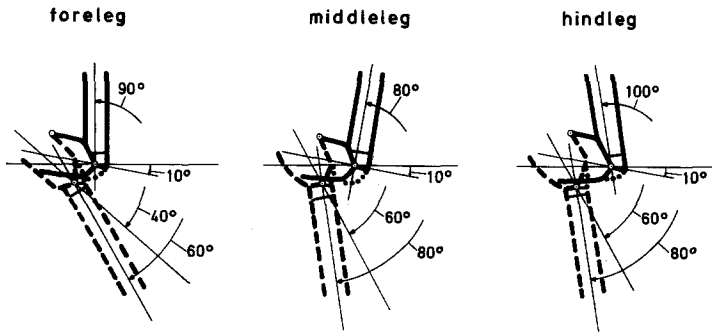

Fig. 3. The extreme position of the coxa and the trochanterofemur of all three legs

the axes of rotation of the coxa-thorax joint given above are valid. There are some exceptions, however, for one can find animals with their bodies lifted high above the surface and have their coxae at the low extreme position. Also if the animal walks with the body hanging from the beam, the coxae of the middle- and hindleg are in the lower extreme position. Again when walking upright the foreleg usually is moved in a range which lies in front of the femur-tibia-plane when it is perpendicular to the horizontal plane. However, in the anterior part of its range of movement the coxa of the foreleg has very little freedom to rotate about the horizontal axis. Therefore the coxa-thorax joint of the foreleg nearly always works as though the joint consists of a single hinge rotating about the semi-vertical axis shown in Figure 2. For this leg the coxa then moves only in the horizontal plane.

In order to calculate the torques acting at the joints from the forces applied to the ground by the tarsus one must also know the angles between leg segments. Although it would be possible to calculate these exactly from two simultaneous views of the leg recorded on film the same information within the accuracy of measurement can be obtained more simply from a plan view of the animal recorded on film and a knowledge of the dimensions of the leg segments. Using single frame analysis the anterior and the posterior extreme position of a tarsus were measured as the distance between the tarsus and a reference plane which is perpendicular to the longitudinal axis of the body and which touches the frontal part of the insect's head (Bässler, 1972). This distance is signed positive, when the tarsus is anterior to that plane and negative, when the tarsus is posterior to it. As these values depend on the length of the body of the animal, they are standardized on a total length of body of 73.2 mm, which is the mean value for these stick insects (s. Table 3). The mean values of the anterior and posterior extreme positions of all tarsi together with their standard deviations are shown in Table 2 for the four different walking situations. As the distances between the right and the left tarsi are also different in the different walking situations, the range of movement of the tarsi in the different walking situations is shown in Figure 4 by bars, which connect the mean values of the anterior and the posterior extreme position of each leg. Additionally those angles are shown in Figure 4, which are formed by the longitudinal axis of the body and the vertical projection of the connecting line between the

**Table 2.** The values (in mm) of the anterior (AEP) and posterior (PEP) extreme positions of the tarsi of the three legs in the different walking situations (see also Fig. 4). The values in brackets show the standard deviation. The minimum sample size of any measurement was  $n=63$

		Walk on the horizontal path	Walk on the horizontal plane	Walk hanging from the horizontal beam	Walk up the vertical path
Foreleg	AEP	11 ( $\pm 3$ )	17 ( $\pm 4$ )	14 ( $\pm 3$ )	18 ( $\pm 9$ )
	PEP	- 7 ( $\pm 4$ )	2 ( $\pm 8$ )	- 5 ( $\pm 3$ )	- 7 ( $\pm 5$ )
Middleleg	AEP	- 17 ( $\pm 2$ )	- 16 ( $\pm 4$ )	- 11 ( $\pm 4$ )	- 11 ( $\pm 6$ )
	PEP	- 35 ( $\pm 4$ )	- 34 ( $\pm 5$ )	- 31 ( $\pm 4$ )	- 33 ( $\pm 12$ )
Hindleg	AEP	- 40 ( $\pm 3$ )	- 39 ( $\pm 3$ )	- 34 ( $\pm 4$ )	- 34 ( $\pm 12$ )
	PEP	- 58 ( $\pm 4$ )	- 58 ( $\pm 4$ )	- 52 ( $\pm 5$ )	- 56 ( $\pm 15$ )

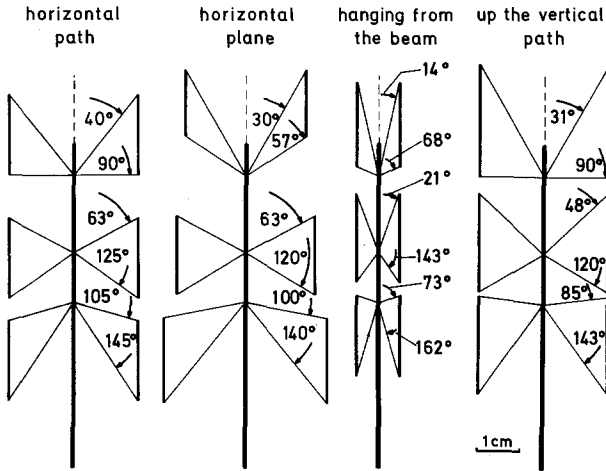

**Fig. 4.** The range of the movement of the tarsi in the different walking situations (see also Table 2)

coxa and the corresponding two extreme positions. These angles can be compared with the angle  $\alpha$  (Fig. 2, Table 1), which describes the position of that femur-tibia-plane, that is perpendicular to the horizontal plane. As mentioned above, for the middle- and the hindleg this femur-tibia-plane is always within the range of movement of the leg, while in the foreleg this range lies mostly in front of that femur-tibia-plane. Additionally one can see, that the values of the extreme positions significantly depend on the kind of this walking situation.

As most investigations dealing with the control of walking in insects are done with the insect walking on a horizontal plane, for this case not only the extreme positions, but also the whole movement of the tarsus was examined. The walking insect was filmed using a mirror to give a simultaneous view from the side and from above. A typical movement cycle of the tarsus of fore-, middle- and hindleg is shown in side elevation and in plan view in Figure 5. Open circles show the position of the tarsus when in the air (protraction).

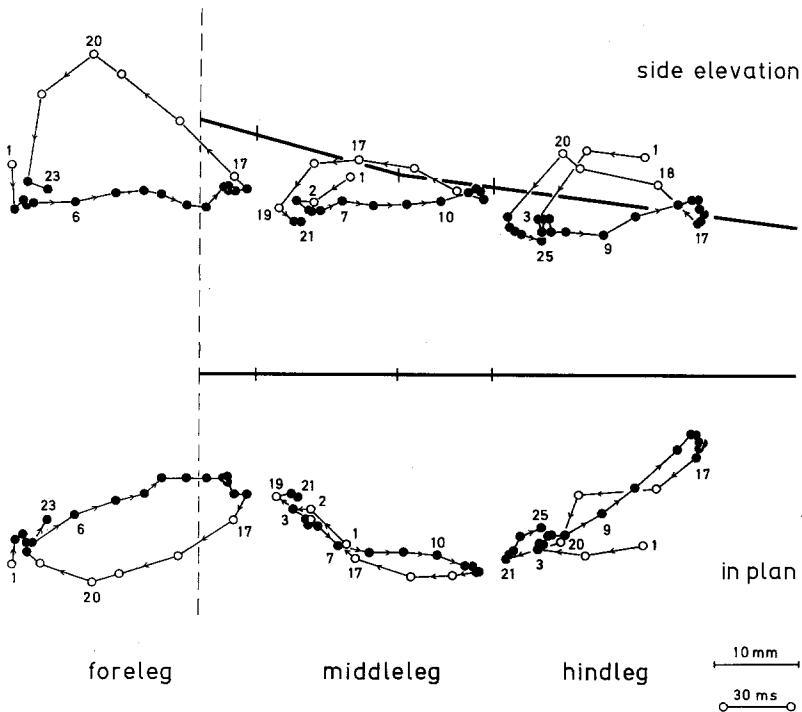

Fig. 5. The movement of the tarsi relative to the body of the insect, when it walks on the horizontal plane, seen in plan and in side elevation. Full circles mean, that the tarsus touches the ground

Closed circles show the position of the tarsus when touching the ground (retraction). Corresponding points in side elevation and in plan for one leg are labelled with the same number. The three cycles of the three legs are taken from different parts of the film. Therefore the same numbers in different legs are not corresponding points in time. The temporal difference between two points amounts to 30 ms. The movement of the tarsus of the middleleg is somewhat atypical, insofar, as the animal in this sequence walked in a slight curve. Therefore the tarsus in the anterior extreme position of the middleleg has moved more towards the inside than usual. Normally the tarsus of the middleleg is moved nearly parallel to the longitudinal axis of the body. In the greater part of the retraction movement, the tarsus is moved backward with a relatively constant speed (Fig. 5). Only sometimes at the beginning, and more often at the end of the retraction movement the tarsus shows within the accuracy of measurement no movement relative to the body.

In Table 3 the mean values of the most important linear measures of the insect body are given together with their standard deviations. These values are obtained from 40 different animals. In Table 4 the mean values (and standard deviations) of the distances between the coxae of the pro-, meso- and metathorax and the walking surface are given for the four different walking situations. These values have been measured in animals, which were filmed from the side.



**Table 3.** The mean values of some linear measures and the total body weight of these stick insects. The values in brackets show the standard deviations. Number of measured animals: 20

Total length of the body	73.2 ( $\pm 4.6$ ) mm
distance between frontal part of the head and	
– coxa of prothorax	7.1 ( $\pm 0.8$ ) mm
– coxa of mesothorax	24.6 ( $\pm 2.1$ ) mm
– coxa of metathorax	35.5 ( $\pm 2.8$ ) mm
– centre of gravity of the whole animal	35.8 ( $\pm 3.0$ ) mm
Foreleg:	
length of coxa	1.6 ( $\pm 0.2$ ) mm
length of trochanterofemur	14.7 ( $\pm 1.3$ ) mm
length of tibia	13.7 ( $\pm 1.4$ ) mm
Middleleg:	
length of coxa	1.5 ( $\pm 0.2$ ) mm
length of trochanterofemur	11.4 ( $\pm 0.9$ ) mm
length of tibia	10.7 ( $\pm 0.9$ ) mm
Hindleg:	
length of coxa	1.5 ( $\pm 0.2$ ) mm
length of trochanterofemur	12.3 ( $\pm 1.5$ ) mm
length of tibia	11.8 ( $\pm 1.7$ ) mm
Total weight	820 ( $\pm 160$ ) mg

**Table 4.** The distance from the base of the coxae to the walking surface for the different walking situations measured in mm. The values in brackets show the standard deviations

	Walk on the horizontal path and the horizontal plane	Walk hanging from the horizontal beam	Walk up the vertical path
Prothorax	9.1 ( $\pm 1.4$ )	19.0 ( $\pm 2.0$ )	7.6 ( $\pm 2.3$ )
Mesothorax	5.9 ( $\pm 0.9$ )	19.0 ( $\pm 2.0$ )	7.3 ( $\pm 2.1$ )
Metathorax	4.3 ( $\pm 0.6$ )	20.0 ( $\pm 2.5$ )	7.8 ( $\pm 2.2$ )

#### D. 1. Walk on the Horizontal Path

The margins of the walking path (30mm broad, 40cm long) consists of two 5mm wide beams of balsa wood joined by black cardboard. When the insect walks on the path, the tarsi usually grasp the balsa beams from above and the side. The forces by which a single leg acts on this balsa beams are measured for each of the three spatial directions. The component parallel to the longitudinal axis of the body is examined first. The typical force pattern is shown in Figure 6a. In all figures the unit of the abscissa is 1 s, and the unit of the ordinate is 1 mN ( $\approx 100$  mp). The walking situation is shown by the schematic drawing and the number of the measured component of the forces is circled. A leg is denoted by the abbreviation f.l. (foreleg), m.l. (middleleg) and h.l. (hindleg). Forces directed posteriorly are signed positive and accelerate the body. Figure 6a shows that the foreleg in this walking situation always decelerates the body. Sometimes at the beginning of a step a small positive force

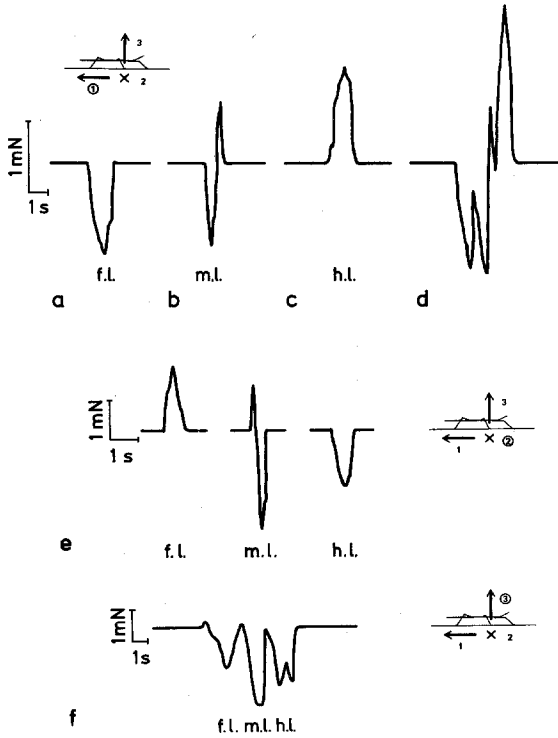

Fig. 6. The different force patterns, measured when the insect walks on the horizontal path. For further explanations see the text

can be seen. In the middleleg (Fig. 6b) one finds a decelerating component in the first part of the force pattern and an accelerating one in the second part. The hindleg (Fig. 6c) always accelerates the body, apart from very small negative forces which sometimes appear at the very beginning or end of the force pattern. Figure 6d shows an example, where all three legs touch the force meter one after the other.

In order to get a quantitative measure for these forces, the amplitudes of which differ to a large extent, the extreme values of these force patterns have been measured and averaged. The corresponding mean values and their standard deviations are shown in Table 5 for all spatial components and for all walking situations. When for instance the insect walks on the horizontal path, the component parallel to the longitudinal axis of the body for the foreleg at first shows a smaller positive peak (mean value 0.32 mN), which cannot be seen in the example of Figure 6a, and then it shows a pronounced negative peak (mean value  $-0.81$  mN).

Figure 6e shows a typical example of the force pattern of the component parallel to the transverse axis of the body. The corresponding mean values again can be read from Table 5: The foreleg always produces forces directed to the inside, the middleleg at first produces forces inwards then in the second part outwards. The hindleg produces only forces outwards. Looking at the

**Table 5.** The mean values and their standard deviations of the forces measured at the extreme points of the different force patterns. The unit is  $10^{-2}$  mN ( $\approx 1$  mp). The last columns show the number ( $n$ ) of evaluated force patterns

	Component parallel to the longitudinal axis of the body	Component parallel to the transverse axis of the body	Component parallel to the vertical axis of the body	
<b>Horizontal path</b>				
foreleg	32 ( $\pm 15$ )/-81 ( $\pm 31$ ) 75	70 ( $\pm 26$ )	24	20 ( $\pm 25$ )/-60( $\pm 31$ ) 57
middleleg	-92 ( $\pm 32$ )/ 89 ( $\pm 35$ ) 74	72 ( $\pm 34$ )/-52 ( $\pm 17$ )	24	-188 ( $\pm 66$ ) 50
hindleg	- 5 ( $\pm 2$ )/ 119 ( $\pm 40$ ) 84 /- 6 ( $\pm 2$ )	-41 ( $\pm 8$ )	19	-160 ( $\pm 40$ ) 53
<b>Horizontal plane</b>				
foreleg	-31 ( $\pm 18$ )/19 ( $\pm 9$ ) 50	12 ( $\pm 11$ )/-5 ( $\pm 6$ )	12	- 51 ( $\pm 26$ ) 71
middleleg	-43 ( $\pm 17$ )/35 ( $\pm 12$ ) 32	9 ( $\pm 3$ )/-84 ( $\pm 17$ )	23	-156 ( $\pm 46$ ) 41
hindleg	73 ( $\pm 25$ ) 54	-96 ( $\pm 17$ )	24	-177 ( $\pm 46$ ) 42
<b>Hanging from the beam</b>				
foreleg	25 ( $\pm 52$ ) 29	29 ( $\pm 38$ )	15	161 ( $\pm 82$ ) 61
middleleg	- 9 ( $\pm 2$ )/ 63 ( $\pm 29$ ) 24	95 ( $\pm 72$ )	13	236 ( $\pm 118$ ) 60
hindleg	14 ( $\pm 5$ )/-72 ( $\pm 40$ ) 19	73 ( $\pm 40$ )	13	389 ( $\pm 91$ ) 42
<b>Up the vertical path</b>				
foreleg	229 ( $\pm 69$ ) 45	202 ( $\pm 102$ )	45	316 ( $\pm 96$ ) 45
middleleg	230 ( $\pm 81$ ) 64	241 ( $\pm 126$ )	64	241 ( $\pm 149$ ) 64
hindleg	186 ( $\pm 65$ ) 53	110 ( $\pm 108$ )/-44 ( $\pm 66$ )	53	31 ( $\pm 103$ )/-113 ( $\pm 112$ ) 53

third spatial component, directed parallel to the vertical axis of the body the middle- and hindlegs because of the effect of the weight of the body always show downward forces (Fig. 6e, Table 5). In the foreleg however, very variable behaviour is found. Sometimes in the force patterns the forces are only positive, sometimes only negative. Very often in one force pattern at first a positive, then a negative force is produced.

## D.2. Walk on the Horizontal Plane

Comparing the results obtained when the insects walk over the walking path with the results when the insects walk over the horizontal plane (Fig. 7), in the component parallel to the longitudinal axis of the body the results are similar with a slight reduction in amplitude of the forces. Considering transverse forces there is an increase in the force directed away from the body for all legs giving approximately zero force where inward forces were present on the path. For the vertical forces the only change occurs in the foreleg where positively

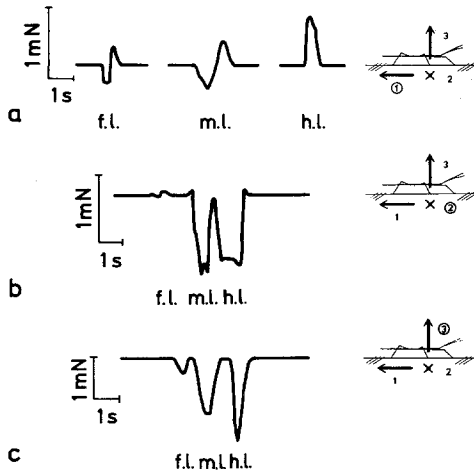

Fig. 7. The different force patterns, measured when the insect walks on the horizontal plane. For further explanations see the text

directed forces vanish and forelegs act in support of the body when in contact with the transducer.

Measuring the forces when the insects walk on a horizontal plane has been done with walking planes consisting of different materials as card board, styrofoam or cloth (calico) glued on a board. No difference could be found within the accuracy of measurement between these materials. Only when using a walking plane consisting of wire-netting (with a width of mesh of 1.7 mm) differences could be found. The results were between those obtained when the insect walks on the usual horizontal plane and when it walks on the horizontal path.

### D.3. Walk with the Body Hanging from the Horizontal Beam

Here the insects walk on a horizontal beam, made from styrofoam, with the body hanging from the beam. The breadth of the beam has been varied between 10 mm and 30 mm, but no qualitative differences in the patterns of the forces could be found. All quantitative measurements were made with a beam of 10 mm breadth, because with this beam width the animals relatively rarely try to deviate from a uniform horizontal walk. Figure 8a shows typical force patterns of the component parallel to the longitudinal axis of the body, produced by the three legs. The foreleg now only develops positive forces that accelerate the body. The same is true for the middleleg, although here sometimes at the beginning a small region of negative values can be observed. In the hindleg at the beginning sometimes a small positive value exists, while the dominant part of that force pattern is given by a pronounced decelerating force (Table 5). The forces parallel to the transverse axis are positive and therefore directed inwards for all legs (Fig. 8b, Table 5). The components parallel to the vertical axis of the body always show negative values (Fig. 8c, Table 5) because the coordinate system is defined relative to the body.

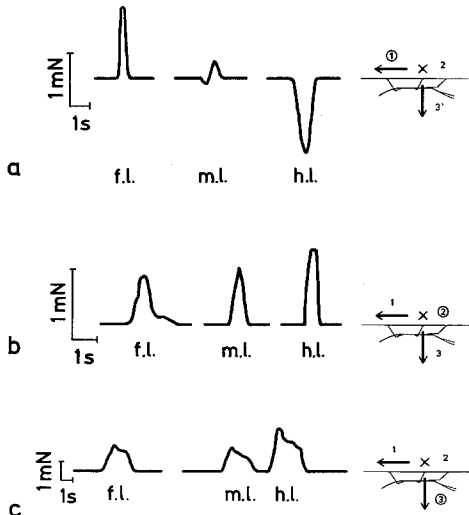

Fig. 8. The different force patterns, measured when the insect walks hanging from the horizontal beam. For further explanation see the text

#### D.4. Walk up the Vertical Path

To use another walking situation in order to look for its influence on the function of the different legs, the insects are investigated when walking on the same walking path as in Section D.1., which however is now mounted vertically. The animals have to walk vertically upward. As mentioned above (Section B), in these series another force meter is used, by which the three spatial components of the forces produced by the leg can be measured at the same time. Therefore the arrangement of the different force patterns is also changed, as now the values of the three components of one leg can be arranged with the same time axis. The upper trace in Figure 9 shows the pattern of the force of the component parallel to the longitudinal axis of the body, the

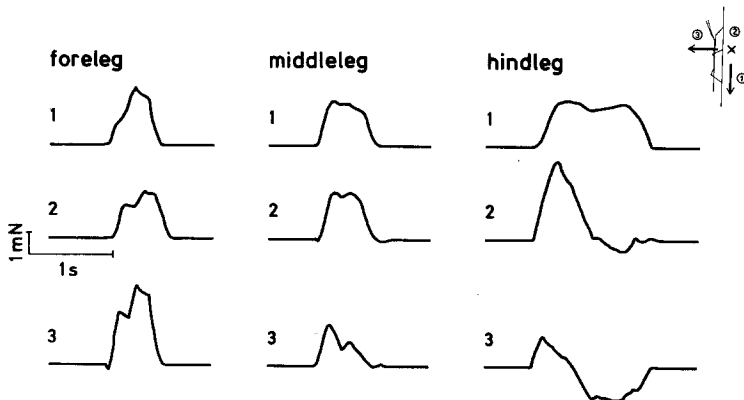

Fig. 9. The different force patterns, measured when the insect walks up the vertical path. For further explanations see the text

middle trace that of the component parallel to the transverse axis and the lower trace that of the component parallel to the dorsoventral axis. Looking at first at the component parallel to the longitudinal axis one can see that all forces have positive values (Fig. 9, Table 5). The component parallel to the transverse axis for the fore- and the middleleg is positive and therefore directed towards the body. This is also the case in the greater part of the force pattern of the hindleg. In the last part however one finds small amplitude negative forces. The component parallel to the dorsoventral axis of the body shows positive values in the foreleg, the middleleg and at the beginning in the hindleg. During a longer period and with a greater amplitude however the forces then produced by the hindleg in this direction are negative.

### **D.5. The Forces at the Beginning and at the End of the Retraction Phase**

To find the time when a leg makes contact with and leaves the transducer, the walking plane (consisting of cardboard) and the platform fixed on the force meter were connected to the two input terminals of an oscilloscope. If the gain of the oscilloscope's amplifier is high enough, because of the high resistance between the terminals there is a given value of 50 Hz noise. When then one tarsus of the insect stepped onto the transducer, the resistance of the circuit was decreased, and the amplitude of the noise decreased significantly.

This method was used to measure within 20 ms the time of setting down and lifting up the tarsus. As measurements of forces parallel to the longitudinal axis of the body show, within this accuracy measurable forces can be seen immediately after the tarsus touches the platform. In the same way at the end of the force pattern the forces show values different from zero until the tarsus is lifted from the ground.

### **E. The Static Situation**

Considering the standing animal one can think of two extreme models describing the function of the muscles controlling the position of the different joints. First one could consider the structure as a completely rigid body. This might be approximated by fixing the position of all joints by the simultaneous activation of the antagonistic muscles so that the joints are rigidly clamped and no significant bending occurs. With this condition a leg of an animal standing on a horizontal plane could produce only forces with vertical but not with horizontal components. Measuring these forces in standing animals, apart from vertical components you find significant values of horizontal components. Therefore the model of the body being rigid cannot be true. Such horizontal forces could however be obtained, if the extreme opposite model was realized. One could think of the animal being a statically stable system although no muscles produce forces at all. The stability under this supposition very much depends on the particular geometry of the body. Although such a possibility is excluded in principle by Borelli (1685) for insects, as a simple case you can imagine,

that some joints are at the end of their travel. This has the effect of reducing the total number of joints and when the number of free joints becomes small enough, the system indeed can stand without activation of muscles. The exact number of free joints depends on the individual geometric properties of the system. It does not appear to be possible to describe the standing insect by this model. However as will be shown later (Section G) in the dynamic situation when the insect is walking, in some cases at least for single pairs of legs the possibility of such an interpretation exists.

As a first approximation, one can treat the insect body as a static structure. The sum of all the forces parallel to the gravity vector for the legs have to equal the total weight of the animal at all times. In the dynamic situation, when in the walking animal the body is moved up and down, this will not be true, since because of the vertical acceleration of the body this sum is greater during an upward movement and smaller during a downward movement. But in walking animals at least the mean value of the sums during a walking period should be equal to the weight of the body, because for a whole walking cycle these effects must cancel each other.

To measure the values of the forces directed vertically, a typical movement cycle of this insect as described by Graham (1972) has been divided up into six different typical arrangements of the legs. Using the measured force patterns belonging to the different legs, the values of those forces can be estimated, which are developed by the single legs in each of these six leg arrangements. When comparing the sum of these forces for each of the six leg arrangements with the average weight of the animals, you find no difference, when considering animals which walk hanging from the horizontal beam. When the insects walk on the horizontal path or on the horizontal plane the measured values are too small by about 40%. The reason for this difference is, that the animals very often drag their abdomen along the ground when walking on the horizontal path or on the horizontal plane but not when hanging from the beam. Measurements in standing animals show that the abdomen indeed acts on the ground with a vertical force of about 35–40% of the weight of the body thus reducing the load supported by the legs.

In the situation, when the animals walk up the vertical path, the forces, which are propelling the body, act in the same direction as the forces, which support the weight of the body. Therefore the forces necessary only to support the body cannot be measured separately in this walking situation and can therefore not be compared with the weight of the body of the animal. It should be mentioned here, that these results do not influence the validity of the considerations dealing with the torques discussed in the following sections.

## **F. General Considerations Concerning the Torques**

If you know the resultant force, by which the leg acts on the ground in an arbitrary moment and the corresponding geometrical arrangement of the leg segments, you can calculate the values of all the different torques, which are produced by the different pairs of antagonistic muscles controlling the position

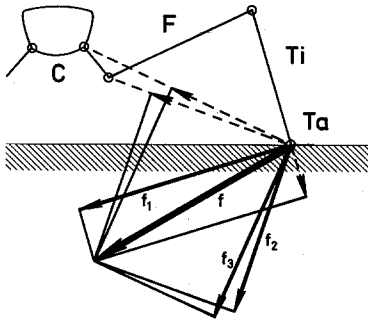

Fig. 10. A schematic drawing to demonstrate the calculation of the different torques. For further explanation see the text

of the joints. This is shown schematically in Figure 10 for the simple case, when the resultant force lies in the femur-tibia-plane (plane of the diagram). Relative to each joint the total force can be split up into two components, one parallel to the line joining the point of rotation of this joint and the point, at which the tarsus acts on the ground (Fig. 10, dashed lines) and the other perpendicular to that line. With this construction one obtains a unique value for the torque at each joint, because the systems of antagonistic muscles have to balance the reaction force measured by the force meter. In a normal hinge joint as in the femur-tibia joint and the coxa-trochanter joint those parts of the forces, which are parallel to this connection line (shown by dashed lines), only act against the pivots of the joints, while the component perpendicular to the corresponding connection line (in Fig. 10 labelled by  $f_i$ ) has to be produced by the system of antagonistic muscles, that move the joint. This is the flexor-extensor system controlling the femur-tibia joint and the flexor-extensor system controlling the coxa-trochanter joint. Therefore the torque produced by such a system of antagonistic muscles can be calculated as the product of that component  $f_i$  and the length of the corresponding arm of lever (length of the connection line between the tarsus and the joint). To describe the torques produced by the muscles of the coxa-thorax articulation this joint is functionally split into two orthogonal hinge joints. One has the axis of rotation as shown in Figure 2, and the other has an axis of rotation lying perpendicular to the first through the dorsal ball joint. The muscles which are involved in the first joint, may be referred to as elements of the protractor-retractor system, while those of the second joint may be referred to as elements of the levator-depressor system. For these two systems the torques can be computed in the same way as in the other joints. It is assumed, that any rotations of the joint about the coxal axis are small. It should perhaps be made clear that these muscle systems are functional classifications and do not preclude the possibility of bifunctional muscles.

Since the resultant force usually lies outside the femur-tibia-plane as shown in Figure 10, the different components of forces belonging to the different joints have to be calculated by three-dimensional graphical constructions. In this way the torques for different positions of each leg in the four walking situations have been calculated. These leg positions are characterized by the angle between the longitudinal axis of the body (posterior direction is signed positive) and



the vertical projection of the line joining coxa and tarsus in that position. Depending on the shapes of the respective force patterns for each leg the torques for a number of typical leg positions is calculated. These positions are chosen so that the values of the torques between these positions can be estimated by interpolation between the calculated values. Since the torques in the anterior and posterior extreme positions always have the value zero, these positions are not included in the following tables. Because of the inaccuracies when measuring the forces and angles the values of the torques can only be given to an accuracy of  $\pm 3 \cdot 10^{-6}$  Nm.

By the method used here you can only calculate the value of the total torque produced by a system of antagonistic muscles but not the values of torques produced by the individual muscles. Therefore, in the tables that muscle of an antagonistic pair is indicated which produces the greater torque. This can be done so much the more, as electrophysiological experiments in free walking insects (most recently confirmed in stick insects by Pflüger (1976); see here for further references) you find an alternative activation of the antagonistic muscles. Therefore one might assume that the torques measured here are mainly produced by one muscle. If a pair of antagonistic muscles both produce a measurable torque at the same time then the torques shown here correspond to the difference between the torques.

If you want to calculate from the torques the forces, which are produced by the different muscles, you have to take into account the distance between the tendon of the muscle and the axis of rotation of the joint. Storrer and Cruse (1975) have measured these distances for the tendons of the flexor and extensor muscles in the femur of *Carausius morosus* as being 0.5 mm each. When assuming for the other joints about the same value, with the limitations made above you can calculate the forces from the torques given in the Tables 6–9 by dividing the values of the torques by the factor of  $0.5 \cdot 10^{-3}$  m. A torque of 10 Nm ( $10^{-6}$ ) for example is obtained, when the muscle produces a force of 20 mN ( $\approx 2$  p).

## G. The Values of the Torques and the Function of the Different Legs

### 1. Walk on the Horizontal Path and on the Horizontal Plane

Comparing the values of the torques, which are computed in the insect walking on the horizontal path (Table 6) with those, when the insect walks on the horizontal plane (Table 7), in most cases one can find no qualitative differences. Therefore these two walking situations will be treated together. Regarding the torques produced by the muscles controlling the femur-tibia joints, you can see, that except for the second part of the retraction movement of the middleleg, the flexor muscle always dominates. Comparing the values of the torques produced by the muscles controlling the femur-tibia joint with the values of the other torques shown in Table 6 and Table 7, you can see, that the first of the two values are relatively small. In particular the value of the torque produced by the flexor of the hindleg, when the insect walks on the horizontal

**Table 6.** Walk on the horizontal path. The muscles, which produce the dominant torque in the different joints, and the total values of the torques produced in the corresponding joints, shown for some characteristic leg positions. The unit is  $10^{-6}$  Nm

	Foreleg		Middleleg			Hindleg
	45°	70°	75°	90°	105°	130°
Femur-tibia joint	flexor 7.7	flexor 5.3	flexor 9.1	extens. 5.5	extens. 3.3	flexor 1.0
Coxa-trochanter joint	extens. 2.4	extens. 11.1	extens. 21.3	extens. 25.0	extens. 16.1	extens. 22.8
Levator-depressor system of the coxa-thorax-joint	depr. 2.8	depr. 13.3	depr. 25.8	depr. 29.8	depr. 19.1	depr. 25.6
Protractor-retractor system of the coxa-thorax joint	protr. 6.0	protr. 18.7	protr. 16.6	0	retr. 5.1	retr. 10.0

**Table 7.** Walk on the horizontal plane. The muscles, which produce the dominant torque in the different joints, and the total values of the torques produced in the corresponding joints, shown for some characteristic leg positions. The unit is  $10^{-6}$  Nm

	Foreleg		Middleleg			Hindleg
	33°	45°	75°	90°	105°	130°
Femur-tibia joint	flexor 6.7	flexor 0.1	flexor 5.1	extens. 1.7	extens. 4.6	flexor 6.8
Coxa-trochanter joint	extens. 11.3	extens. 7.8	extens. 21.9	extens. 17.7	extens. 14.4	extens. 35.6
Levator-depressor system of the coxa-thorax joint	depr. 12.7	depr. 9.1	depr. 26.3	depr. 21.1	depr. 17.7	depr. 39.2
Protractor-retractor system of the coxa-thorax joint	retr. 8.5	protr. 0.2	protr. 2.5	0	protr. 2.6	protr. 1.8

path, cannot be discriminated from zero within the accuracy of measurement. Therefore one must conclude, that the muscles controlling the femur-tibia joint in all legs produce only relatively small torques in this situation.

The torques for the coxa-trochanter joint in all legs show that the extensor is strongly active. As the levator-depressor system of the coxa-thorax joint works in parallel with the muscle system of the coxa-trochanter joint and as the distance between both joints is very small, the torques produced by the levator-depressor system of the coxa-thorax joint are about equal to the torques produced by the flexor-extensor system of the coxa-trochanter joint except of a factor usually somewhat greater than one. Therefore in both walking situations discussed here the depressor is dominant.

When looking at the protractor-retractor system of the coxa-thorax joint, you find considerable differences between the torques produced in the two different walking situations. Therefore these results will be treated separately for the two walking situations.

*Plane.* When the insect walks on the horizontal plane, in the first part of the retraction of the foreleg the retractor is dominant, while during the greater part of the retraction no measurable torques can be seen. Altogether the forces produced by the foreleg in this walking situation are very small compared with those of the other legs. This fact, as well as the other observation, that the forelegs very often make groping movements, when the insect walks on the horizontal plane, support the assumption, that in this walking situation the forelegs have rather a feeler function than a walking function. The values of the forces parallel to the vertical axis seem to be higher than the real mean values, because during such groping movements no forces could be measured at all, which therefore do not contribute to the average. Possibly the forelegs can be used in two different ways in this walking situation: either as feeler producing nearly no measurable forces, or as walking legs only producing forces in the vertical direction and therefore having a pure supporting function. In the middlelegs the values of the torques produced by the protractor-retractor system are always so small, that they cannot be discriminated from zero because of the accuracy of measurement being  $\pm 3 \cdot 10^{-6}$  Nm. In addition when walking on the plane the longitudinal forces (Fig. 7a) are directed anteriorly when the tarsus is forward and posteriorly, when the tarsus is to the rear. Both longitudinal forces and the calculated torques for the protractor-retractor system suggest that the middleleg is only used as a passive strut supporting the body. As will be shown later, this is not the case when the insect walks on the horizontal path.

Since in the walk on the horizontal plane the force parallel to the longitudinal axis of the body is much higher in the hindleg than in the fore- or the middleleg, you could assume, that the essential function of the hindleg in the walking animal is to accelerate the body. However, in spite of a retraction movement in the coxa-thorax joint and an extension movement in the femur-tibia joint, you find a nonsignificant predominance of the protractor in the coxa-thorax joint and a significant predominance of the flexor of the femur-tibia joint. This seems to be a contradiction, because here just those muscles are predominating, which produce a movement in the direction opposite to the observed one. It also is somewhat unexpected, that at the same time, although the protractor of the coxa-thorax joint and the flexor of the femur-tibia joint are predominating, the component of forces parallel to the longitudinal axis of the body shows high positive values (forces directed posterior, Table 5). This shows, that in walking animals you cannot simply conclude from the direction of movement which muscles are involved. As an explanation of this unexpected result you can say, that in this walking situation the function of the hindlegs is not only to accelerate the body, but to support it. Therefore during the extending movement of the femur-tibia joint the predominating flexor prevents the metathorax and the abdomen from being pressed to the ground by their own weight.

*Path.* Although the two situations, when the insect walks on the horizontal plane or on the horizontal path seem to be rather similar, the function of the legs in both situations differ significantly. The forces produced by the forelegs show much higher amplitudes, when the insect walks on the horizontal path than when it walks on the horizontal plane. This corresponds to the observation, that on the horizontal path the forelegs are moved much more regularly than on the horizontal plane and that they perform also very rarely these groping movements, which very often can be seen, when the insect walks on the horizontal plane. Therefore on the horizontal path the forelegs seem to be much more integrated in the process of walking itself than on the horizontal plane. As shown in Table 6, in spite of the retraction movement of the foreleg always the protractor of the coxa-thorax joint predominates. From these results and from the values of the forces measured parallel to the longitudinal axis of the body, which were found mainly to be negative, you have to conclude, that the function of the foreleg in this walking situation is surprisingly to decelerate the body during the most part of the retraction movement.

In the middleleg the force pattern of the component parallel to the longitudinal axis of the body qualitatively is the same when the insect walks on the horizontal path and when it walks on the horizontal plane. Therefore you might expect, that on the horizontal path as on the horizontal plane the middlelegs have only a supporting function. The torques however, which are produced by the protractor-retractor system of the coxa-thorax joints, are significantly different from zero (Table 6). This means, that the middlelegs have not only a supporting function, but that they additionally decelerate the body in the first part of the retraction movement and accelerate the body in the second part, whereby the total amount of acceleration is smaller than that of the deceleration.

While in the hindlegs the protractor of the coxa-thorax joint predominates in a small degree, when the insect walks on the horizontal plane, on the horizontal path the retractor is predominating significantly (Tables 6, 7). This corresponds to the fact, that the forces parallel to the longitudinal axis of the body produce a much higher acceleration of the body on the horizontal path than on the horizontal plane. Although you consequently find some quantitative differences between the forces produced by the hindlegs in both walking situations, it qualitatively has the same function in both situations: When walking on the horizontal path the hindleg has a supporting function as well as an accelerating function, with the latter being more important compared with the situation, when the insect walks on the horizontal plane.

The higher value of the force to accelerate the body produced by the hindleg seems to be necessary to overcome the decelerating forces produced by the middle- and the foreleg. Taking into account the coordination of the fore- and the middlelegs (Graham, 1972), and then summing up the effect of the forces parallel to the longitudinal axis of the body at all four legs, one finds, that in the walking animal the fore- and the middlelegs act together to decelerate the body nearly all the time. This decelerating function of the fore- and middlelegs is best understood by regarding the whole animal as a static three-centered arch. This arch construction shown in Figure 11 is formed by the fore- and

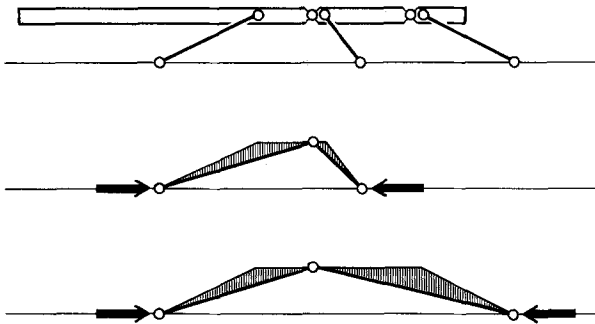

**Fig. 11.** Schematic representation of the articulation of the stick insect body showing the decomposition of the structure into two three-centered arches. The forces shown are the reactions to the horizontal components of forces applied to the ground by the legs. The joints are shown by circles

the middlelegs on one side and the hindlegs on the other side, with both parts being connected by the thorax. One possibility to prevent this arch from collapsing because of its own weight, is to activate the muscles of each joint in such a way that the whole structure becomes rigid. Then at the tarsi only vertical forces would be measured. If the muscles of one joint are activated less, horizontal forces have to be produced additionally to prevent the body from collapsing. This is the case in a static three-centered arch. According to this principle the function of the reaction forces shown in Figure 11 produced by the middle- and forelegs parallel to the longitudinal axis of the body and those produced by the hindlegs are understood to unburden the muscles controlling one of the joints involved in this arch. Figure 11 assumes as an illustration that the meso-metathoracic articulation is the upper joint of the three-centered arch.

## 2. Walk Hanging from the Horizontal Beam

The torques, which are produced by an animal, that walks hanging from the horizontal beam, are computed in the same way (Table 8). In the femur-tibia joints of all legs the flexor always predominates, whereas in both walking situations discussed above where the insect walks upright, in the second part of the retraction movement of the middleleg the extensor predominates. Another difference is that the values of the torques produced by the flexor tibialis of the middleleg and of the hindleg are much higher than those in the first two walking situations. The torques produced in the coxa-trochanter joint and by the levator-depressor system of the coxa-thorax joint are however much smaller than in the upright walking animals. In the foreleg and in the first part of the retraction movement of the middleleg the values cannot be discriminated from zero within the accuracy of measurement. In the greater part of the retraction of the middleleg and in the whole retraction of the hindleg the extensor of the coxa-trochanter joint

**Table 8.** Walk hanging from the horizontal beam. The muscles, which produce the dominant torque in the different joints, and the total values of the torques produced in the corresponding joints, shown for some characteristic leg positions. The unit is  $10^{-6}$  Nm

	Foreleg				Middleleg				Hindleg			
	30°		60°		25°		80°		80°	130°		
Femur-tibia joint	flexor	6.9	flexor	5.9	flexor	0.7	flexor	16.3	flexor	23.2	flexor	24.2
Coxa-trochanter joint	flexor	0.6	extens.	1.8	flexor	2.8	extens.	12.4	extens.	5.0	extens.	6.1
Levator-depressor system of the coxa-thorax joint	lev.	2.0	depr.	1.4	lev.	3.3	depr.	13.6	depr.	4.2	depr.	6.3
Protractor-retractor system of the coxa-thorax joint	protr.	12.8	retr.	0.6	protr.	17.0	retr.	9.4	protr.	3.2	protr.	1.3

and the depressor of the coxa-thorax joint dominate. This is again surprising, because one would expect, that to carry the weight of the body of the hanging insect the flexor of the coxa-trochanter joint and the levator of the coxa-thorax joint should dominate. The reason for this different result may be, that apart from forces in the vertical direction to prevent the body from slipping off the beam rather high forces parallel to the transverse axis of the body have to be produced to ensure good contact with the beam.

The torques produced by the protractor-retractor system of the coxa-thorax joint of the foreleg show a significant predominance of the protractor in the first part of the retraction movement, while in the second part the values cannot be discriminated from zero. Since in the first part of the retraction movement the angle between the longitudinal axis of the body and the line between coxa and tarsus is very small (Fig. 4), the protractor develops forces rather in the direction of the transverse axis of the body than in the direction of its longitudinal axis. Similar as discussed above, the function of the foreleg therefore would be to prevent the body from slipping off the beam. In the second part of the retraction movement these forces are produced by the flexor of the femur-tibia joint. Therefore and because of the value of the forces shown in Table 5 you can assume that the function of the foreleg in this walking situation is in a small degree to accelerate the body, but mainly is to support it. Comparing the values of the component parallel to the vertical axis of the body with the corresponding values in the two walking situations discussed above this becomes more evident, because the relative amount of the absolute values of these forces in the foreleg are much higher in the situation, when the insect walks hanging from the beam.

In the middleleg as in the foreleg in the short first part of the retraction movement the relatively high forces parallel to the transverse axis of the body are produced by the protractor of the coxa-thorax joint, while in the most

part of the retraction movement these forces are developed by the flexor of the femur-tibia joint and in the middleleg additionally by the extensor of the coxa-trochanter joint and the depressor of the coxa-thorax joint. As the component of forces parallel to the longitudinal axis shows, the middleleg in the short first part of the retraction movement decelerates the body and in the second part it produces a stronger and longer lasting acceleration (Table 5). Therefore the middleleg has apart from its supporting function also an accelerating function.

When the insect walks hanging from the horizontal beam, the anterior extreme position of the tarsus of the hindleg is shifted in anterior direction so far, that a small part of the range of movement of the hindleg lies in front of the coxa (Fig. 4). In this small section the forces parallel to the longitudinal axis of the body are accelerating, while during the rest of the retraction movement these forces act in a decelerating way. As the torques produced by the protractor-retractor system of the coxa-thorax joint are very small, as for the middleleg in the situation when the animal walks on the horizontal plane (Section G.1.), one must conclude that here the hindleg has only supporting function.

When you regard the cooperation of the forces parallel to the longitudinal axis of the body of all legs, you can assume similarly to the case of the insect walking on the horizontal path, that the animal forms a hanging three-centered arch, since now the forelegs and the middlelegs essentially produce accelerating forces, while the hindlegs produce decelerating forces. In the animal hanging from the beam this construction might have the corresponding effect as in the animal walking on the horizontal path. One of the joints of this arch, e.g. the meso-metathoracic joint may thereby be prevented from being bent by the weight of the body itself, although the muscles controlling the position of this joint produce very weak or no forces at all.

### 3. *Walk up the Vertical Path*

Although the two situations, when the insect walks on the horizontal path and on the horizontal plane, at first sight seem to be very similar, significant differences in the function of the legs in both walking situations could be confirmed. In spite of the increase of these differences, when you additionally look at the further situation, when the insect walks hanging from the horizontal beam, in all three walking situations you can find several common properties in the activation of the different muscles: In the coxa-trochanter joint no significant predominance of the flexor muscle is found. The same is true for the levator of the levator-depressor system of the coxa-thorax joint except for one case (Table 8), where the torque produced by the levator is somewhat higher than the accuracy of measurement. Apart from a few exceptions the torques produced by the flexor of the femur-tibia joint are very small. The extensor of this joint sometimes dominates by a small margin. All these results change for the situation where the animal walks up a vertical path.

Since the forelegs and the middlelegs only show quantitative, but no qualitative differences (Table 9), they will be treated together. In both cases the flexor

**Table 9.** Walk up the vertical path. The muscles, which produce the dominant torque in the different joints, and the total values of the torques produced in the corresponding joints, shown for some characteristic leg positions. The unit is  $10^{-6}$  Nm

	Foreleg		Middleleg		Hindleg		
	60°		85°		100°	130°	
Femur-tibia joint	flexor	34.0	flexor	23.8	flexor	8.6	extens. 13.0
Coxa-trochanter joint	flexor	29.8	flexor	14.3	flexor	2.9	extens. 8.7
Levator-depressor system of the coxa-thorax joint	lev.	36.5	lev.	16.7	lev.	3.5	depr. 10.1
Protractor-retractor system of the coxa-thorax joint	retr.	7.6	retr.	35.7	retr.	35.0	retr. 24.1

of the femur-tibia joint is strongly dominant. The values of the torques in these joints are never approached in any other walking situation. Different to all other walking situations in the foreleg as well as in the middleleg the flexor of the coxa-trochanter joint and the depressor of the levator-depressor system of the coxa-thorax joint dominate their antagonists. Again the corresponding torques have very high values. In the protractor-retractor system of the coxa-thorax joint always the retractor dominates.

In the hindleg in the first part of the retraction movement you find similar relationships to those in the fore- and middleleg, as there is a predominance of the flexor in the femur-tibia joint, and also of the flexor of the coxa-trochanter joint and of the levator of the coxa-thorax joint. Except of the latter however the values of the torques are relatively weak. The very strong predominance of the retractor in the coxa-thorax joint also continues in the second part of the retraction movement. In this second part you find for the first time in the hindleg a significant predominance of the extensor of the femur-tibia joint. In all other walking situations during the extension movement of the femur-tibia joint of the hindleg the flexor was predominating. The muscles controlling the coxa-trochanter joint and the levator-depressor system of the coxa-thorax joint however work in this part of retraction movement, as it is known from the other walking situations: In the coxa-trochanter joint the extensor dominates and in the levator-depressor system of the coxa-thorax joint the depressor dominates.

In the walking situation, when the insect walks up the vertical path, the forces to support the body and those to accelerate it point in the same direction, which is the direction of gravity. For this reason you cannot discriminate between the supporting function and the accelerating function of the different legs. The forces parallel to the vertical axis of the body (Table 5) can be understood for geometrical reasons. In this walking situation the tarsi of the forelegs and the middlelegs are always above the centre of gravity of the insect's body, as it is also the case in the first part of the retraction movement of the hindleg. Therefore in these cases the value of these forces should become positive, while



in the second part of the retraction movement of the hindleg, where the tarsus is below the centre of gravity of the body, negative values should arise. As it is to be seen in Table 5 and Figure 9, the measured forces indeed show these properties.

## H. Discussion

The results of the present investigation show, that the function of the different groups of muscles as well as the function of the whole leg can vary considerably depending on the type of walking situation. Since the walking insect needs a neuronal program, by which the temporal pattern of activation of the different muscles is controlled, the question arises, whether the change of the measured forces in the different walking situations is a consequence of a change in this program or whether it is only a consequence of the change of the mechanical situation. This question is of interest, because even if the insect was a completely rigid structure one would measure different forces depending on the changes in position relative to the direction of gravity.

In both walking situations, when the insect walks on the horizontal path and when it walks on the horizontal plane, the direction of gravity is the same. Therefore according to the assumption, that the change of the forces would be only a consequence of the change of the mechanical situation, in these two walking situations no difference should be found in the forces of all three spatial directions, which is not true (Table 5). Also the changes of the anterior and the posterior extreme positions of the tarsi in the different walking situations should not arise, if the neuronal program itself was not influenced. Therefore you have to conclude from these results, that the neuronal program itself is changed, when the walking situation changes.

This neuronal program can be assumed to consist of a main program controlling several subprograms, which again control the leg muscles themselves. Some of these subprograms might for example consist of servomechanisms controlling the angle of a joint or the value of a torque produced by an antagonistic system of muscles. You might then assume, that the different sensory inputs, caused by the different walking situations, might influence the neuronal program only at such low level subprograms as these two types of servomechanisms are. This at least cannot be the only way of influencing the program. If closed loop control mechanisms, the reference input of which are independent of the sensory inputs, control the values of the torques produced in the different joints, the values of the corresponding torques in the different walking situations would not be allowed to differ in such a high degree, especially not, when comparing the torques in the two walking situations on the horizontal path and on the horizontal plane, because here, as mentioned above, in both situations the direction of gravity is the same. If in the same way closed loop control mechanisms controlled only the values of angles of the joints, then, depending on the walking situation, the reference input might change, because on the narrow beam the angles of the joints have to be changed in order to get tarsal contact. Irrespective of this, neither the values of the extreme positions of

the tarsi are allowed to be changed nor for example the differences between the activation of the protractor-retractor system of the coxa-thorax joint of the middleleg, when the insect walks on the horizontal path or on the horizontal plane could be explained by this hypothesis.

By means of this consideration you have to assume, that the sensory input in the different walking situations at least additionally influences the central program at a higher level. The repetition of the following examples should show, that these influences can be rather dramatic: Concerning the protractor-retractor system of the coxa-thorax joint of the middleleg, this system seems to be totally switched off, when the insect walks on the horizontal plane (Section G.1.). The same muscle system is controlled in different ways in each of the two situations, when the insect walks on the horizontal path or when it walks hanging from the horizontal beam, without being able to explain this by the change of the direction of gravity (Section G.1., G.2.). Another example, whereby even the whole leg changes its function can be seen in the foreleg, which is used mainly as a feeler, when the insect walks on the horizontal plane (Section G.1.). According to this the torques produced by the protractor-retractor system of the coxa-thorax joint of this leg show a significant difference, when the insect walks on the horizontal plane and when it walks on the horizontal path. Comparing the protractor-retractor system of the coxa-thorax joints of the hindlegs in both situations, also significant differences can be observed. The last two observations are the essential reasons for the assumption, that a static three-centered arch is built up in the situation, when the insect walks on the horizontal path, but not, when it walks on the horizontal plane. Also the change of the forces parallel to the transverse axis of the body is a result of an influence of the sensory input on the central program at a higher level than given by the two servomechanisms discussed. The strong differences, which are found between the situation, when the insect walks up the vertical path, and the other situations, have however not necessarily to be the result of such kind of influence on the central program. It cannot be excluded, that in this situation the change of the values of the different torques is caused by the activation of servomechanisms, which control the angle of the joints. But as in this situation the gravity does not act parallel to the vertical axis of the body, but parallel to the longitudinal axis of the body, it is not easily possible to discriminate, whether the change of the torques in this situation depends on the change of the central program or only on the change of the mechanical situation.

As there are such dramatic changes depending on the different walking situations, you might assume, that there might exist some distinct central programs, each of which is "switched on", when the corresponding walking situation occurs, and which after that works without essential sensory feedback. But this does not seem to be true, because you can find transitions between such "programs" in other walking situations. In the walking situation not mentioned before where the insect walks on the horizontal plane, but trailing a weight fixed to the body by a thread, one finds about the following result. When looking at the forces parallel to the longitudinal axis of the body, in this situation the values of the decelerating forces in the foreleg and the middleleg

are smaller, while the accelerating parts become larger compared with the forces in the situation, when the insect walks freely on the horizontal plane. But still the maximum amplitude of the accelerating force of the hindleg is higher than that of the foreleg and the middleleg. This situation may correspond to a walk up an inclined plane, or perhaps better to a squeezing through a hindering foliage, and indeed these results lie between those of the walk on the horizontal plane and those of the walk up the vertical path. Similarly the results, when the insect walks on the horizontal plane, but with the weight pulling in (not against) the direction of walking lie between those, when the insect walks freely on the horizontal plane and those when the insect walks down the vertical path. If only some distinct central programs existed, you would not expect such transitions, if not the intermediate walking situation under view generated an own program, which by chance is similar to the other two programs and so only seems to be a transition program. Therefore it seems much more to be probable, that there is one central program, possibly consisting of a main program and some subprograms, which all the time is directly influenced by the sensory input.

This supposition in principal is similar to some models proposed by means of electrophysiological investigations (Pearson et al., 1973; Pearson and Iles, 1973; Delcomyn, 1973) insofar, as there is required a mixing between central and sensory influence in the way, that the sensory influence modifies the central commands. On the other hand one has to take into account, that the forces developed by the single legs are very variable, although this cannot be seen in the "typical" examples shown in Figures 6-9. These force patterns are typical in the sense, that they demonstrate about the mean shape of all measured force patterns. The rather strong variability can however be concluded from the values of the standard deviations shown in Table 5. This means, that the signals of those sensory organs, that measure the force in a direct or an indirect way, also vary in a high degree even from one step to the other within the same walking situation. Therefore this influence on the central program can presumably not be done by strong reflexes, which give a yes-or-no-reaction depending on whether the reflex overcomes it's threshold or not. For example Pearson et al. (1973) give a model, in which the value of the forces, by which the leg acts on the ground, and which are measured by the campaniform sensillae on the trochanter of the cockroach, produces the lifting up of the tarsus and so the beginning of the protraction movement. Looking at the force patterns of individual steps, in all three components you find very different shapes with positive, zero and negative values without the tarsus being lifted. Therefore at least in the case of the slowly walking stick insect a model using strong reflexes seems to be improbable. According to these results the problem remains unsolved, that on the one hand the sensory influence should be weak enough, that the accidental variability of an individual step produces no essential effects, while on the other hand it has to be strong enough to produce the dramatic changes in the activation of the different muscles, which can be found in the different walking situations. One possibility to answer this question might be, that not only one, but several sensory inputs, which probably don't come only from different sense organs of the leg itself, but also from those of the remaining

part of the body, have to act together. By this way accidental variations might be compensated.

I wish to express my thanks to Prof. N. Göpfert and Dr. D. Graham for helpful discussions and the latter for proof reading the English manuscript.

## References

- Bässler, U.: Proprioceptoren am Subcoxal- und Femur-Tibia-Gelenk der Stabheuschrecke *Carausius morosus* und ihre Rolle bei der Wahrnehmung der Schwerkraftrichtung. *Kybernetik* **2**, 168–193 (1965)
- Bässler, U.: Zur Beeinflussung der Bewegungsweise eines Beines von *Carausius morosus* durch Amputation anderer Beine. *Kybernetik* **10**, 110–119 (1972)
- Borelli, A.: *De motu animalium*. Rom (1685)
- Burns, M.D.: The control of walking in Orthoptera. I. Leg movements in normal walking. *J. exp. Biol.* **58**, 45–58 (1973)
- Burrows, A.: Physiological and morphological properties of the metathoracic common inhibitory neuron of the locust. *J. comp. Physiol.* **82**, 59–78 (1973)
- Delcomyn, F.: Motor activity during walking in the cockroach *Periplaneta americana*. II. Tethered walking. *J. exp. Biol.* **59**, 643–654 (1973)
- Delcomyn, F., Usherwood, D.N.R.: Motor activity during walking in the cockroach *Periplaneta americana*. I. Free walking. *J. exp. Biol.* **59**, 629–642 (1973)
- Graham, D.: A behavioural analysis of the temporal organisation of walking movements in the 1st instar and adult stick insect (*Carausius morosus*). *J. comp. Physiol.* **81**, 23–52 (1972)
- Hughes, G.M.: The coordination of insect movement. I. The walking movements of insects. *J. exp. Biol.* **29**, 267–285 (1952)
- Hughes, G.M.: The coordination of insect movement. II. The effect of limb amputation and the cutting of commissures in the cockroach (*Blatta orientalis*). *J. exp. Biol.* **34**, 306–333 (1957)
- Pearson, K.G., Fournier, C.R., Wong, R.K.: Nervous control of walking in the cockroach. In: Control of posture and locomotion. (Stein, R.B., Pearson, K.G., Smith, R.S., Redford, J.B., eds.). New York-London: Plenum Press 1973
- Pearson, K.G., Iles, J.F.: Nervous mechanisms underlying intersegmental coordination of leg movements during walking in the cockroach. *J. exp. Biol.* **58**, 725–744 (1973)
- Pflüger, H.-J.: Lauf- und Schaukelbewegung bei der Stabheuschrecke *Carausius morosus* Br. (Orthoptera, Phasmida). Dissertation Universität Kaiserslautern (1976)
- Storrer, J., Cruse, H.: Zur Regelung der Femur-Tibia-Stellung bei *Carausius morosus*. Kraftmessung am Flexor und Extensor tibialis. In: Proceedings of the Jurema 1975 (Muljević, V., ed.), pp. 59–67. Zagreb 1975
- Wendler, G.: Laufen und Stehen der Stabheuschrecke: Sinnesborstenfelder in den Beingelenken als Glieder von Regelkreisen. *Z. vergl. Physiol.* **48**, 198–250 (1964)