

The Functional Assessment of Balance in Concussion (FAB-C) Battery

by

Thaer El Manaseer

A thesis submitted in partial fulfillment of the requirements for the degree of

Doctor of Philosophy

in

Rehabilitation Science

Faculty of Rehabilitation Medicine
University of Alberta

© Thaer El Manaseer, 2020

ABSTRACT

Background: Current evidence suggests that athletes may be susceptible to subsequent injury after returning to play following a sport-related concussion (SRC). It is hypothesized that this increased risk may be due in part to residual postural control deficits that are not detectable with common clinical measures of postural control.

Objective: To develop and perform a preliminary evaluation of a new clinical postural control battery to inform return-to-play decisions following SRC called the Functional Assessment of Balance in Concussion (FAB-C).

Methods: A stepwise process was used to develop the FAB-C. Initially, components of postural control that could potentially be impacted by an SRC were identified through a systematic review and theoretical conceptualizations of postural control (studies one and two). Next, the FAB-C was compiled by including existing clinical tests that assessed potentially impacted components of postural control. New clinical tests were developed when none existed. The agreement (i.e., intraclass correlation coefficient or Kappa coefficients and 95%CI), and precision (i.e., standard error of measurement and minimal detectable change at 95% confidence level) of the individual clinical tests that comprise the FAB-C were then assessed in a sample of uninjured active participants (studies three and four). Finally, the feasibility (i.e., battery completion, FAB-C components correlation, adverse events, cost and administration time) and construct validity [i.e., differences (mean and standard deviation, median and range or proportion and 95% CI) in FAB-C outcomes between uninjured participants and participants who had recently returned to play following an SRC) of the FAB-C were examined (study five).

Results: A SRC can impact postural control by dysregulating sensory integration, control of dynamics (i.e., increased medial-lateral center-of-mass displacement and decreased gait velocity), and movement strategies (i.e., reaction time). Deficits in these components can only be thoroughly assessed under single-task, dual-task, and sport-specific testing paradigms. Three clinical tests (Balance Error Scoring System, Tandem Gait Test, and Clinical Reaction Time) assessed under single- and dual-task conditions, and a fourth fit-for-purpose Sport-Related Postural Control Test were included in the FAB-C. Depending on the clinical test of interest, ICC estimates ranged from 0.24 to 0.99, and kappa coefficients varied between 0.03 and 0.90. ICC estimates for most of the single-task tests, all dual-task tests, and the Sport-Related Postural Control Test were ≥ 0.7 . The Balance Error Scoring System, Tandem Gait Test, and Clinical Reaction Time demonstrated higher precision under the dual-task testing condition compared to the single-task task testing condition. With respect to feasibility, 100% of uninjured participants and 86% of participants who had recently returned to play following an SRC were able to complete the FAB-C. Between component correlation coefficients were < 0.7 . No adverse effects were reported. FAB-C cost was less than \$100CAD with a median administration time of 49 (44-60) minutes. A greater percentage of uninjured participants passed individual FAB-C components (range 52%-82%) compared to participants who had recently returned to play following an SRC (range 17-66%).

Conclusion: The FAB-C is a novel clinical assessment tool that aims to target different components of postural control that may be affected following SRC. Although promising, the FAB-C requires further evaluation before widespread use in clinical settings. FAB-C may provide clinicians with a practical framework around which to diagnose and treat postural control deficits after SRC.

PREFACE

This thesis is an original work by Thaer Manaseer under the supervision of Douglas P. Gross, Professor in the Department of Physical Therapy at the University of Alberta; Jackie L. Whittaker, Assistant Professor in the Department of Physical Therapy at the University of Alberta; and Kathryn Schneider, Associate Professor in Faculty of Kinesiology at the University of Calgary. The University of Alberta's Health Research Ethics Board approved the research studies in this thesis (No: Pro00077091, Date: December 19, 2017). The study in Chapter 2 was published in the Clinical Journal of Sport Medicine. The study in Chapter 3 was published in the Journal of Physiotherapy Theory and Practice. The study in Chapter 4 has been provisionally accepted for publication in The International Journal of Sports Physical Therapy.

DEDICATION

I dedicate this work to my most precious treasures in life, my family who encouraged me to go on every adventure, especially this one.

Thaer Manaseer

ACKNOWLEDGMENTS

I would like to express my sincere appreciation to my supervisors: Prof. Douglas Gross, Dr. Jackie Whittaker, and Dr. Kathryn Schneider. Their continued support and guidance have always been my strongest motivation and the essential source of energy behind this work.

I am highly grateful to my wife and daughters for their support over the last five years. This work would not be completed without you. I am also thankful to my dearest parents, brothers, and lovely sister for their tremendous support. Last but not least, I would like to thank the Hashemite University for the financial support throughout the years of my Ph.D.

TABLE OF CONTENTS

CHAPTER 1 - INTRODUCTION.....	1
1.1 Background	1
1.2 The postural control system	2
1.3 Sport-related concussion and postural control	3
1.4 The role of postural control assessment in sport-related concussion.....	4
1.5 Postural control assessment following sport-related concussion	6
1.6 Risk of injury after return to play following sport-related concussion	9
1.7 Problem statement.....	11
1.8 Goals and specific research objectives.....	11
1.9 Dissertation format.....	12
1.10 References	14
CHAPTER 2 – GAIT DEVIATIONS ASSOCIATED WITH CONCUSSION: A SYSTEMATIC REVIEW	25
2.1 Introduction	27
2.2 Methods.....	29
2.2.1 Data sources and search	29
2.2.2 Study selection	30
2.2.3 Data extraction and study rating process	30
2.2.4 Data synthesis	31
2.3 Results	32
2.3.1 Identification of studies.....	32
2.3.2 Study characteristics	32

2.3.3	Study quality and level of evidence	34
2.3.4	Synthesis of results	35
2.4	Discussion	35
2.4.1	Limitations	39
2.4.2	Recommendations.....	39
2.5	Conclusion.....	40
2.6	References	41
2.7	Tables	47
2.8	Figures.....	70
CHAPTER 3 – RE-CONCEPTUALIZING POSTURAL CONTROL ASSESSMENT IN SPORT-RELATED CONCUSSION: TRANSITIONING FROM THE REFLEX/HIERARCHICAL MODEL TO THE SYSTEMS MODEL		72
3.1	Introduction	74
3.2	Sport-related concussion and the Reflex/Hierarchical Model for postural control.....	75
3.3	Sport-related concussion and the Systems Model for postural control.....	76
3.3.1	Movement strategies	78
3.3.2	Control of dynamics.....	79
3.3.3	Sensory strategies.....	81
3.3.4	Cognitive contributions.....	82
3.3.5	Orientation in space	83
3.3.6	Biomechanical elements	85
3.4	Sport-related concussion and the Systems Model for postural control: Critique and summary.....	86
3.5	Implications for future research and clinical assessment of postural control impairments following sport-related concussion.....	87

3.6	Conclusion.....	89
3.7	References	90
3.8	Tables	101
3.9	Figures.....	103

CHAPTER 4 – THE RELIABILITY OF CLINICAL POSTURAL CONTROL TESTS UNDER SINGLE-TASK AND DUAL-TASK TESTING PARADIGMS 105

4.1	Introduction	107
4.2	Methods.....	109
4.2.1	Design	109
4.2.2	Participants.....	109
4.2.3	Procedures.....	110
4.2.4	Outcome measures	111
4.2.5	Analysis.....	113
4.3	Results	113
4.3.1	Participants.....	113
4.3.2	Relative reliability.....	114
4.3.3	Absolute reliability.....	115
4.4	Discussion	115
4.4.1	Clinical recommendations	118
4.4.2	Strengths and limitations.....	118
4.5	Conclusion.....	119
4.6	References	121
4.7	Tables	127
4.8	Figures.....	134

CHAPTER 5 - POSTURAL CONTROL ASSESSMENT FOLLOWING SPORT-RELATED CONCUSSION: THE DEVELOPMENT AND RELIABILITY OF A NEW SPORT-SPECIFIC TEST 138

5.1 Introduction 140

5.2 Methods 141

 5.2.1 Defining the measurement construct 142

 5.2.2 Generating a pool of potential clinical postural control tests 142

 5.2.3 Expert review of clinical postural control tests..... 143

 5.2.4 Pilot testing 143

5.3 Results 146

 5.3.1 Defining the measurement construct 146

 5.3.2 Generating a pool of potential clinical postural control tests 147

 5.3.3 Expert review of clinical postural control tests..... 148

 5.3.4 Pilot testing 148

5.4 Discussion 151

 5.4.1 Strengths and limitations..... 153

5.5 Conclusion..... 153

5.6 References 155

5.7 Tables 160

5.8 Figures 166

CHAPTER 6 – THE FUNCTIONAL ASSESSMENT OF BALANCE IN CONCUSSION (FAB-C) BATTERY 169

6.1 Introduction 171

6.2 Methods 172

 6.2.1 Development of the FAB-C battery 172

6.2.2	Participants.....	173
6.2.3	Procedures.....	174
6.2.4	Outcomes	174
6.2.5	Analysis.....	175
6.3	Results	176
6.3.1	FAB-C battery development.....	176
6.3.2	Participant characteristics	179
6.3.3	Feasibility.....	180
6.3.4	Differences in performance between uninjured and injured participants	181
6.4	Discussion	182
6.4.1	Strengths and limitations.....	184
6.5	Conclusion.....	185
6.6	References	186
6.7	Tables	194
CHAPTER 7 – GENERAL DISCUSSION AND CONCLUSIONS.....		212
7.1	Introduction	212
7.2	Theoretical foundations of the FAB-C.....	212
7.2.1	Gait deviations following sport-related concussion.....	212
7.2.2	Shifting the framework for understanding postural control in sport-related concussion.....	213
7.3	A novel clinical postural control assessment tool (the FAB-C).....	214
7.3.1	Tests considered for inclusion into the FAB-C.....	214
7.3.2	Introducing the FAB-C	216
7.4	Preliminary evaluation of the FAB-C	217

7.5	Limitations of the research.....	217
7.6	Clinical practice.....	220
7.7	Future directions.....	221
7.7.1	Reliability and validity.....	221
7.7.2	Postural control recovery pattern following sport-related concussion	222
7.7.3	Further development of the FAB-C	223
7.8	Knowledge translation.....	223
7.9	Conclusions	224
7.10	References	226

LIST OF TABLES

Table 2-1: Summary of Concussion Definition and Diagnosis Guidelines	47
Table 2-2: Systematic Review – Characteristics of Included Studies	51
Table 2-3: Systematic Review – Summary of Significant and Non-significant Gait Parameters by Quantity and Quality	68
Table 3-1: Underlying Postural Control Systems Operational Definitions	101
Table 4-1: Descriptive Statistics for the BESS, TGT, and CRT by Session, Rater, and Task ...	127
Table 4-2: Intra- and Inter-rater Reliability Estimates for the BESS, TGT, and CRT by Session, Rater, and Task	129
Table 4-3: Intra- and Inter-rater Reliability Estimates for the BESS, TGT, and CRT by Session, Rater, and Task	130
Table 4-4: Kappa Statistic (κ) Estimates for the Pass/Fail Task in the Tandem Gait Test.....	131
Table 4-5: Summary Data Associated with Bland-Altman Plots for the BESS, TGT, and CRT under Single-Task and Dual-Task Testing Conditions.....	132
Table 5-1: Participant Characteristics	160
Table 5-2: Summary Statistics for the Sport-Related Postural Control Test by Variation, Session, and Rater	161

Table 5-3: Intra- and Inter-Rater ICC, SEM, and MDC for Time Component of the Sport-Related Postural Control Test	162
Table 5-4: Kappa Statistics for the Pass/Fail Component of the Sport-Related Postural Control Test	164
Table 5-5: Summary Data Associated with Bland-Altman Plots for the Components of the Sport-Related Postural Control Test	165
Table 6-1: Candidate Clinical Tests for Possible Inclusion in the Functional Assessment of Balance in Concussion (FAB-C) Battery.....	194
Table 6-2: Participant Characteristics.....	205
Table 6-3: Summary Statistics for Participant Performance on the FAB-C Battery	206
Table 6-4: Multitrait Spearman Correlation Matrix among Postural Control Tests in Healthy Control Participants	209

LIST OF FIGURES

Figure 2-1: Systematic Review - Study Identification PRISMA Flowsheet	70
Figure 3-1: Systems that Underlie Postural Control.....	103
Figure 3-2: A New Model of Postural Control Assessment in Sport-Related Concussion	104
Figure 4-1: The Balance Error Scoring System.....	134
Figure 4-2: The Tandem Gait Test.....	135
Figure 4-3: The Clinical Reaction Time Test	136
Figure 4-4: Bland-Altman plot of the Tandem Gait Test	137
Figure 5-1: The Design of the Final Version of a Sport-Related Postural Control Test for Postural Control Assessment following Sport-Related Concussion.....	166
Figure 5-2: Bland-Altman Plots of the Difference in Sport-Related Postural Control Test between Trials and Sessions against the Mean Difference	167

LIST OF APPENDICES

Appendix 1: Systematic Review – Search Strategies and Results.....	266
Appendix 2: Systematic Review – Unique Articles Identified by Database	272
Appendix 3: Bland-Altman Plots for the BESS, TGT, and CRT under Single-Task and Dual-Task Testing Conditions.	273
Appendix 4: The Preliminary Version of a Sport-Related Postural Control Test for Postural Control Assessment following Sport-Related Concussion.	277
Appendix 5: The Final Sport-Related Postural Control Test with Scoring, Examiner, and Patient Instructions.....	280
Appendix 6: The Functional Assessment of Balance in Concussion (FAB-C).....	284

LIST OF ABBREVIATION

95% CI - 95% Confidence Interval
AAN - The American Academy of Neurology
ACRM - The American Congress of Rehabilitation Medicine
A-P - Anterior-Posterior
BESS - The Balance Error Scoring System
CISG - Concussion in Sport Group
COM - Center-of-mass
COMD - Center-of-mass displacement
COM-COPS - Center-of-mass center-of-pressure separation
COMV - Center-of-mass velocity
COP - Center-of-pressure
D&B criteria - Downs and Black criteria
DT - Dual-task paradigm
GRTPP - Graded Return to Physical Activities Protocol
GV - Gait velocity
M-L - Medial-lateral
mTBI - Mild Traumatic Brain Injury
NATA - The National Athletic Training Association
OCEBM - The Oxford Centre of Evidence-Based Medicine
PRISMA - The Preferred Reporting Items for Systematic reviews and Meta-Analysis
RTP - Return-to-play
SOT - Sensory Organization Test
SL - Stride length
SRT - Stride time
STL - Step length
STW - Step width
TBI - Traumatic Brain Injury
TGT - The Tandem Gait Test
WHO - The World Health Organization

CHAPTER 1- INTRODUCTION

1.1 BACKGROUND

Canadian youth have high sports and recreation participation.[1] While sports and recreation participation enhances overall physical and psychological health,[2] sports and recreation participation is the leading cause of injury in Canadian youth.[3] Sport-related concussion (SRC) is one of the most frequently reported injuries in Canadian youth.[4] For example, Statistics Canada reported that the majority (i.e., 64%) of emergency department visits among Canadian youth (i.e., 10-18 years old) in 2016 were due to injuries related to participation in sports and recreational activities.[5] Of those, 39% were diagnosed as SRC while a further 24% were possible SRC.[5] SRC has been reported to account for approximately 15% of the overall injury burden in youth athletes.[6, 7]

SRC is defined as “a traumatic brain injury induced by biomechanical forces”. [8] A SRC is not associated with alterations on standard structural imaging but can result in a vast range of acute neurophysiological signs and a multitude of symptoms that may persist for differing lengths of time.[8] Common short-term findings include symptoms (e.g., headache), physical signs (e.g., neurological deficits), postural control impairments (e.g., gait unsteadiness), behavioral changes (e.g., irritability), cognitive deficits (e.g., slow reaction time), and sleep disturbance (e.g., sleeping more than usual).[8] Possible long-term consequences of SRC include cognitive impairments,[9] postural control impairments,[10] and limited future participation in sports and recreational activities.[11]

The current consensus in SRC evaluation includes the use of a subjective examination, supported by multifaceted assessment batteries designed to target the various functions of the brain.[12] Postural control assessment forms an important component of this multifaceted assessment.[12] Historically, postural control assessment following SRC has included clinical tests that challenge the brain's ability to integrate sensory cues from the visual, vestibular, and somatosensory mechanisms.[13] This approach to postural control assessment, however, has been criticized for its limited ability to identify potential lingering postural control impairments following SRC.[14] Thus, there is a need to develop objective clinical measures of postural control that can aid in the assessment and monitoring of SRC, as well as to inform return-to-play (RTP) decisions following SRC.[8]

1.2 THE POSTURAL CONTROL SYSTEM

The postural control system consists of sensory, motor, and sensorimotor integration processes.[15] The sensory processes involve somatosensory, visual, and vestibular mechanisms. The visual mechanism provides information about the location of the body in space, the relation between body parts, and body motion in relation to the surrounding environment. Located in the inner ear, the vestibular labyrinth provides information related to the position and movement of the head. Finally, the somatosensory mechanism relies on mechanoreceptors located in the skin, muscles, joints, and ligaments to identify the position of the body in space.[15] Sensory information from these mechanisms is used in both feedback and feedforward processes. Feedback is information about the state of the body or body part. The feedforward process involves prediction and anticipation to prepare for imminent threats to stability.[16] Motor processes, on the other hand, involve outputs from the central nervous system to lower motor neurons. The

central outputs are attuned to the environmental context by sensory inputs and are mediated by the reticulospinal, vestibulospinal, and medial corticospinal tracts.[16]

Sensorimotor integration processes occur at multiple levels in the central nervous system including higher brain centers (i.e., basal ganglia, cerebellum, and the motor cortex), brain stem, and spinal cord. Overall, the higher brain centers are involved with the cognitive programming of movement.[15, 17] That said, individually each of these centers has more specific roles. While the basal ganglia are important to the initiation and continuation of repetitive tasks (e.g., walking) as well as maintaining posture and muscle tone, the cerebellum has a key role in the sensorimotor integration process, as well as the timing, progression, and smoothing of movement. In contrast, the brain stem has a major role in the processing of sensory input from various sensory mechanisms and the stabilization of posture.[15, 17] Finally, the spinal cord is involved in the initial processing of somatosensory information, and the reflex and voluntary control of posture through the motor neurons.[15]

The main functional goals of the postural control system include both postural orientation and equilibrium. Postural orientation involves the control of body alignment related to gravity, the support surface, visual surroundings, and internal references (i.e., representation of the body and world in the brain that is formulated based on the integration of sensory inputs). Postural equilibrium, on the other hand, involves the stabilization of the body's center of mass during both self-initiated and externally initiated disturbances in postural stability.[18] Postural control dysfunctions are frequently detected in neurologically impaired populations such as in individuals with SRC.[8]

1.3 SPORT-RELATED CONCUSSION AND POSTURAL CONTROL

Previous observational investigations involving the use of laboratory measures have examined the association between SRC and postural control and, in turn, identified aspects of impaired postural control across a variety of tasks. For instance, injured athletes demonstrated impaired static postural control (i.e., increased postural sway) that persisted up to 40 days following the initial injury compared to uninjured controls.[19] Similarly, injured athletes demonstrated impaired gait parameters (e.g., increased medial-lateral center-of-mass displacement, decreased peak anterior center-of-mass velocity, and increased peak medial-lateral center-of-mass velocity) for up to eight weeks following injury compared to uninjured controls.[20] To-date, there is a lack of consensus regarding which gait parameters are the most important to inform both the diagnosis of SRC and RTP decisions.

Several assumptions have been proposed to explain the physiological basis of postural control impairment that stems from SRC. For instance, it has been proposed that SRC alters postural control by causing functional disturbances in the cerebral cortex and reticular formation [21]; impairing cognitive functions [22]; disturbing the interaction of brain regions [23]; and/or limiting the central nervous system's ability to process and integrate sensory input from the visual, vestibular, and somatosensory mechanisms.[13] Although the underlying physiological basis of the resulting postural control impairment is not yet fully understood, postural control assessment remains a key component to the assessment of SRC.

1.4 THE ROLE OF POSTURAL CONTROL ASSESSMENT IN SPORT-RELATED CONCUSSION

SRC is a heterogenous injury that does not present the same way in every person.[24] The Sport Concussion Assessment Tool 5 has been recommended as a multifaceted screening tool in the

acute phase (i.e., initial 24-48 hours) following SRC.[24] The tool consists of two portions: on-field assessment and in-clinic assessment portions. The on-field assessment of SRC includes screening for red flags, documenting observable signs, memory assessment, the Glasgow coma scale, and a short cervical spine screen.[12, 24] The in-clinic assessment portion, on the other hand, includes a history, symptom reports, cognitive assessment, neurological screen, and postural control examination.[12] During the acute phase following an SRC, follow-up for medical assessment, and an initial period of both cognitive and physical rest is recommended.[24] Additional assessment tools that target vestibular and oculomotor signs and symptoms can be considered in the subacute phase (i.e., 2-10 days) following SRC.[25] After an initial 24–48 hours of cognitive and physical rest, a gradual and sequential RTP is recommended.[8, 24]

If symptoms are not resolved within 7–10 days following SRC, a thorough multifaceted assessment is warranted to facilitate management and/or appropriate referrals.[24] The assessment should include symptom reports, a neurological examination, cervical spine examination, exertion testing, headache assessment, and postural control assessment.[24] Examples of postural control assessments include sensorimotor integration examination, oculomotor and vestibular functions testing, and static and dynamic postural control examination.[24]

As shown in the discussion above, the assessment of postural control is a constituent component of the multifaceted assessment of SRC. For instance, it assists with identifying an individual who has sustained an SRC, making decisions related to RTP progression, and deciding whether injured individuals are ready to RTP. Next is a thorough discussion on the standard clinical postural control tests most commonly used in SRC.

1.5 POSTURAL CONTROL ASSESSMENT FOLLOWING SPORT-RELATED CONCUSSION

Currently, the Tandem Gait Test and Balance Error Scoring System (BESS) are the standard clinical postural control tests most commonly used in SRC.[12] These tests are fast, inexpensive, and easy to use in sports settings. Used to evaluate dynamic postural control ability, the Tandem Gait Test involves walking in a forward direction as quickly and accurately as possible down and back along a 38mm-wide three-meter line, with an alternate foot heel-to-toe gait. During the test, the administrator notes whether a patient steps off the line, separates his/her heel and toe, or touches the administrator or an object for support.

Previously, the Tandem Gait Test was scored based on the time an individual requires to complete the test.[26] It has been suggested that uninjured athletes can complete the Tandem Gait Test in 14 seconds.[27] Athletes with an acute SRC, in contrast, require more than 14 seconds to complete the test.[27, 28] That said, other studies have criticized the limited clinical utility of the 14-second cutoff point due to the variability in the Tandem Gait Test baseline times,[28] and the fact that up to 75% of uninjured athletes may fail to meet the 14-second cutoff point.[29] The timing component of the Tandem Gait Test was, therefore, replaced with a subjective (yes/no) assessment of an injured athlete's ability to perform the test without errors.[12] The Tandem Gait Test has demonstrated moderate-excellent test-retest reliability (intra-class correlation coefficient [ICC] range of 0.7 to 1.0) in athletic populations (age range=15-40 years) in both sexes.[30-32] Further, the test has demonstrated excellent inter-rater reliability (ICC>0.9) in athletic populations (age range=16-37 years) in both sexes.[31] This test has also been shown to accurately discriminate

between injured and uninjured youth and collegiate athletes immediately following SRC (Area Under the Curve [AUC]=0.87).[28]

The BESS is used to evaluate static postural control, and involves three stances (double, single, and tandem). Each stance takes 20 seconds to complete and is performed on both a firm and unstable (i.e., foam) surface with eyes closed. Both the testing surface (e.g., hard floor, filed, etc.) and footwear (e.g., shoes, tape, barefoot, or braces) should be standardized during the BESS as these factors may induce variability in individuals' performance.[12] In a given scenario, the tested individuals may perform the BESS with their shoes on during baseline testing to mimic real-world application of BESS testing during a sideline situation following an SRC.[12, 33] The BESS is scored based on the total number of errors an individual commits with lower scores indicating better postural control ability. Possible errors include stepping, stumbling, or falling; lifting hands off of the iliac crest; opening eyes; moving the hip into more than 30 degrees of abduction; lifting the forefoot or heel; or remaining out of test position for more than five seconds. Age- and sex-specific normative values for the BESS in youth (5-13 years old), high school, and collegiate athletes is available, which provides a reference to assist in clinical decision making across multiple providers caring for athletes with SRC.[34]

Several studies used the BESS to examine postural control ability in athletes with acute (i.e., within three days) SRC.[35-38] Participants included either collegiate athletes or a mix sample of college and high school athletes representing both sexes. Across studies, the authors used a control group, baseline scores, or a combination of both for comparison. The studies demonstrated that athletes with acute SRC tend to commit more errors on the BESS, which typically returns to baseline levels within three to five days after the initial injury.

Studies examining the psychometric properties of the BESS have shown that the BESS correlated with force plate measures for criterion-related validity.[39] Further, the test demonstrated high construct validity in identifying postural control impairments in athletes with SRC.[36-38, 40] The BESS has demonstrated moderate (ICC=0.60) to excellent (ICC=0.92) intra-tester reliability,[41, 42] and moderate (ICC=0.57) to good (ICC=0.85) inter-tester reliability for the total BESS score in uninjured athletic populations (age range=9-26 years) in both sexes.[39, 41-46] The six different stance positions of the BESS have demonstrated moderate (ICC=0.50) to good (ICC=0.88) intra-rater reliability, and moderate (ICC=0.44) to good (ICC=0.83) inter-rater reliability in uninjured individuals.[47] Finally, the BESS has demonstrated good (ICC=0.78-.83) intra-tester,[48] and good (ICC=0.87) inter-tester reliability for the total BESS among athletes with SRC.[49]

Compared to the full BESS, it is recommended to use a modified version of the BESS (i.e., m-BESS) as a sideline measure of postural control following SRC as additional equipment is often not available. The m-BESS only involves the three stances on firm ground, and follows the same scoring procedures as the full BESS.[12] Normative performance values on the m-BESS is currently available for adult individuals (20-69 years old),[50] high school athletes,[51] and youth (5-13 years old).[52]

Previous studies have used the m-BESS to examine postural control in athletes with acute (i.e., within one day) SRC.[53, 54] The recruited samples included either collegiate athletes or a mixed sample of college and high school athletes from both sexes. Across studies, the authors used pre-season baseline scores for comparison. The studies demonstrated that athletes with acute SRC tend to commit more errors in the m-BESS compared to their baseline score. The m-BESS demonstrated construct validity to discriminate between injured and uninjured athletes (AUC=0.64).[55] The m-

BESS has demonstrated good (ICC=0.80) inter-rater reliability in uninjured adults (mean age=23.3, standard deviation=3.8).[56] The test-retest and inter-rater reliability ICCs for the m-BESS ranged from 0.52 to 0.54 in high school and collegiate athletes.[53]

Every clinical outcome measure has its limitations, and both the Tandem Gait Test and BESS are not exceptions. For instance, Schneiders et al [32] found that performance on the Tandem Gait Test improves after 15 minutes of moderate intensity exercise. Schneiders et al [30] also reported that time to perform the Tandem Gait Test varies with the nature of the testing surface (grass, hardwood court, artificial grass), with footwear resulting in faster performance than when the test is performed barefoot. Similarly, the BESS is prone to from a learning effect as Valovich et al [45] found that the number of errors decreases with each consecutive BESS trial. Furthermore, the BESS suffers from a fatigue effect, with a higher number of errors observed after an exercise session compared to no exercising.[57] Each of the issues described will affect the validity of these outcome measures, and should be given careful consideration when using the measures.

While both the Tandem Gait Test and BESS (or m-BESS) are highly sensitive acutely following SRC, their sensitivity to detect postural control impairments decreases over the first three to five days following injury.[8, 13, 49, 58] Further, these assessments may not be challenging (i.e., advanced sport-specificity) enough to detect postural control impairments in high-level athletes.[14] Thus, the Tandem Gait Test and BESS (or m-BESS) may not be appropriate measures of postural control to assist in making safe and timely RTP decisions following SRC due to ceiling effects and limited ability to detect changes after three to five days following an SRC.

1.6 RISK OF INJURY AFTER RETURN TO PLAY FOLLOWING SPORT-RELATED CONCUSSION

Several studies have examined the risk of musculoskeletal injury after RTP following SRC.[59-68] The recruited samples included groups of athlete of various ages (i.e., high school and collegiate athletes) and skill levels from both sexes. Across studies, injury tracking period ranged from 42 days to 24 months after RTP. The studies demonstrated that athletes with SRC had a significantly higher odds of musculoskeletal injury after RTP than uninjured athletes (odds ratio=2.11; 95% CI=1.46-3.06).[69, 70]

Previous studies have also examined the risk of sustaining a subsequent SRC after RTP following a concussion.[71-78] The recruited samples included groups of athlete of various ages (i.e., high school and collegiate athletes) and sport (i.e., ice hockey, Rugby, American football) with and without a previous concussion. Overall, these studies demonstrated that athletes with a previous concussion had a threefold to sixfold increased risk in sustaining a subsequent SRC.[79]

While the underlying cause for the increased injury risk is not yet known, it has been suggested that neuromuscular control deficits that go undetected at RTP following SRC may contribute to risk.[69, 70] This hypothesis is supported further by preliminary evidence from studies examining brain activity in athletes with SRC using electroencephalogram. For instance; Tremblay [80] examined the brain activity in a sample of 12 athletes with a history of multiple SRC. Compared to 12 uninjured controls, injured athletes demonstrated abnormal brain activity in the primary motor cortex while somatosensory processing and sensorimotor integration were at normal levels. Barr [23] reported that such abnormal brain activity could persist beyond the point of recovery on clinical measures (i.e., Concussion Symptom Inventory, Standardized Assessment of Concussion, the BESS, and Automated Neuropsychological Assessment Metrics) that are commonly used for making RTP decisions following SRC. Thus, development of new clinical assessment measures

to postural control to better identify persistent postural control impairment prior to RTP following SRC is needed.[8, 23, 81]

1.7 PROBLEM STATEMENT

SRC is a common injury among athletes. Due to its heterogeneous nature and complexity, SRC causes impairments in multiple clinical domains including postural control. Both the Tandem Gait test and BESS (or m-BESS) are the current standard for postural control assessment following SRC. These postural control assessments are highly sensitive during the acute phase following SRC, but their sensitivity to detect postural control impairments decreases over the first three to five days following the initial injury. This suggests that even though an athlete with a SRC demonstrates normal levels of postural control ability relative to his/her baseline performance on these tests, physiological impairments may continue to exist and the athlete may RTP with residual postural control impairments,[69] which may increase their risk of future injury. Further, these assessments are not challenging enough to detect postural control impairments in high-level athletes. Thus, there is a need to develop objective clinical measures of postural control that can aid in the assessment and monitoring of SRC, as well as to inform RTP decisions following SRC. Building a case for such clinical measures, however, requires identifying which dynamic postural control parameters are the most important for SRC diagnosis or to inform RTP decisions, as well as understanding the physiological basis of postural control impairment that stems from SRC.

1.8 GOALS AND SPECIFIC RESEARCH OBJECTIVES

The goal of this thesis was to present the rationale for, develop and perform a preliminary evaluation of a new clinical postural control assessment tool (named the Functional Assessment

of Balance in Concussion [FAB-C] battery) to assist in diagnosis of SRC and RTP decisions following SRC. Specific objectives of the research were to;

1. Identify quantifiable gait deviations associated with concussion across populations and time since the injury.
2. Discuss the physiological basis of postural control impairment that stems from SRC based on the Reflex/Hierarchical and the Systems Models of postural and movement control.
3. Examine and compare the relative and absolute reliability of three clinical postural control tests under single- and dual-task conditions in uninjured active youth and young adults.
4. Develop a sport-related postural control test that is appropriate for SRC and examine its relative and absolute reliability in a sample of uninjured active youth and young adults.
5. Examine the feasibility and preliminary construct validity of the FAB-C battery in active youth and young adults with and without SRC.

The knowledge gained from this research is intended to provide a foundation for a comprehensive and challenging postural control testing protocol for evaluating postural control recovery status following SRC. This is expected to assist with RTP decisions following SRC, and will ultimately contribute to an improvement in long-term player welfare.

1.9 DISSERTATION FORMAT

Chapter 2 is a systematic review (published in Clinical Journal of Sport Medicine) that identifies, summarizes and evaluates the current evidence examining quantifiable gait deviations associated with concussion across populations and time since the injury. Chapter 3 is a narrative review (published in journal of Physiotherapy Theory and Practice) that discusses the physiological basis

of postural control impairment that stems from SRC based on the Reflex/Hierarchical and the Systems Models of postural and postural control. Chapter 4 is single-group, repeated-measures study (provisionally accepted for publication in The International Journal of Sports Physical Therapy) that examines and compares the relative and absolute reliability of the Balance Error Scoring System, Tandem Gait Test, and Clinical reaction Time Test under both single- and dual-task conditions in uninjured active youth and young adults. Chapter 5 is a single-group, repeated-measures study that examines the relative and absolute reliability of a novel sport-related postural control test that is appropriate for SRC in uninjured active youth and young adults. Finally, Chapter 6 is a cross-sectional study examining the feasibility and preliminary construct validity of the FAB-C battery in active youth and young adults with and without SRC. Chapter (7) discusses the main findings of the five manuscripts and provides directions for future research.

1.10 REFERENCES

1. Statistics Canada. Table 13-10-0096-01 Health characteristics, annual estimates. DOI: <https://doi.org/10.25318/1310009601-eng>
2. Organization WH. Global recommendations on physical activity for health. Switzerland: Geneva;2010. Available from: <https://www.who.int/dietphysicalactivity/global-PA-recs-2010.pdf> [Accessed 22nd June 2019].
3. Sheu Y, Chen LH, Hedegaard H. Sports- and Recreation-related Injury Episodes in the United States, 2011-2014. *Natl Health Stat Report*. 2016;(99):1-12.
4. King MA, Pickett W, King AJ. Injury in Canadian youth: A secondary analysis of the 1993-94 health behaviour in school-aged children survey. *Can J Public Health*. 1998;89(6):397-401.
5. Canada Go. Concussion in sport 2016 [updated May 02, 2018; cited 2018 September 24]. Available from: <https://www.canada.ca/en/canadian-heritage/services/concussions.html>.
6. Emery C, Tyreman H. Sport participation, sport injury, risk factors and sport safety practices in Calgary and area junior high schools. *J Paediatr Child Health*. 2009;14(7):439-44.
7. Emery CA, Meeuwisse WH, McAllister JR. Survey of sport participation and sport injury in Calgary and area high schools. *Clin J Sport Med*. 2006;16(1):20-6.
8. McCrory P, Meeuwisse W, Dvorak J, Aubry M, Bailes J, Broglio S, et al. Consensus statement on concussion in sport-the 5(th) International Conference on Concussion in Sport held in Berlin, October 2016. *Br J Sports Med*. 2017;51(11):838-47.

9. Guskiewicz KM, Marshall SW, Bailes J, McCrea M, Cantu RC, Randolph C, et al. Association between recurrent concussion and late-life cognitive impairment in retired professional football players. *Neurosurgery*. 2005;57(4):719-26.
10. Pan T, Liao K, Roenigk K, Daly JJ, Walker MF. Static and dynamic postural stability in veterans with combat-related mild traumatic brain injury. *Gait Posture*. 2015;42(4):550-7.
11. Emery CA, Black AM, Kolstad A, Martinez G, Nettel-Aguirre A, Engebretsen L, et al. What strategies can be used to effectively reduce the risk of concussion in sport? *Br J Sports Med*. 2017;bjsports-2016-097452.
12. Echemendia RJ, Meeuwisse W, McCrory P, Davis GA, Putukian M, Leddy J, et al. The Sport Concussion Assessment Tool 5th Edition (SCAT5): background and rationale. *Br J Sports Med*. 2017;51(11):848-50.
13. Guskiewicz KM. Balance assessment in the management of sport-related concussion. *Clin Sports Med*. 2011;30(1):89-102, ix.
14. Johnston W, Coughlan GF, Caulfield B. Challenging concussed athletes: the future of balance assessment in concussion. *QJM*. 2016;110(12):779-83.
15. Shumway-Cook A, Woollacott MH. *Motor control: translating research into clinical practice*. 3rd ed. Philadelphia: Lippincott Williams & Wilkins; 2007.
16. Lundy-Ekman L. *Neuroscience: fundamentals for rehabilitation* 4th ed. St. Louis, MO: Elsevier Health Sciences; 2013.

- 17.Sabin MJ. Reliability and validity of the Condition-Modified Star Excursion Balance Test: Influence of concussion history[dissertation]. University of Illinois; 2011.
- 18.Horak FB. Postural orientation and equilibrium: what do we need to know about neural control of balance to prevent falls? *Age Ageing*. 2006;35 Suppl 2(SUPPL.2):ii7-ii11.
- 19.Powers KC, Kalmar JM, Cinelli ME. Recovery of static stability following a concussion. *Gait Posture*. 2014;39(1):611-4.
- 20.Howell DR, Osternig LR, Chou LS. Adolescents demonstrate greater gait balance control deficits after concussion than young adults. *Am J Sports Med*. 2015;43(3):625-32.
- 21.Shaw NA. The neurophysiology of concussion. *Prog Neurobiol*. 2002;67(4):281-344.
- 22.Catena RD, van Donkelaar P, Chou L-S. Altered balance control following concussion is better detected with an attention test during gait. *Gait Posture*. 2007;25(3):406-11.
- 23.Barr WB, Prichep LS, Chabot R, Powell MR, McCrea M. Measuring brain electrical activity to track recovery from sport-related concussion. *Brain Inj*. 2012;26(1):58-66.
- 24.Schneider KJ. Concussion-Part I: The need for a multifaceted assessment. *Musculoskelet Sci Pract*. 2019;42:140-50.
- 25.McDevitt J, Appiah-Kubi K, Tierney R, Wright W. Vestibular and oculomotor assessments may increase accuracy of subacute concussion assessment. *Int J Sports Med*. 2016;37(09):738-47.

26. McCrory P, Meeuwisse WH, Aubry M, Cantu RC, Dvorak J, Echemendia RJ, et al. Consensus statement on concussion in sport--the 4th International Conference on Concussion in Sport held in Zurich, November 2012. *PM R*. 2013;5(4):255-79.
27. Howell DR, Osternig LR, Chou LS. Single-task and dual-task tandem gait test performance after concussion. *J Sci Med Sport*. 2017;20(7):622-6.
28. Galetta KM, Morganroth J, Moehringer N, Mueller B, Hasanaj L, Webb N, et al. Adding vision to concussion testing: a prospective study of sideline testing in youth and collegiate athletes. *J Neuroophthalmol*. 2015;35(3):235-41.
29. Santo A, Lynall RC, Guskiewicz KM, Mihalik JP. Clinical utility of the Sport Concussion Assessment Tool 3 (SCAT3) Tandem-Gait Test in high school athletes. *J Athl Train*. 2017;52(12):1096-100.
30. Schneiders AG, Sullivan SJ, Kvarnstrom J, Olsson M, Yden T, Marshall S. The effect of footwear and sports-surface on dynamic neurological screening for sport-related concussion. *J Sci Med Sport*. 2010;13(4):382-6.
31. Schneiders AG, Sullivan SJ, Gray AR, Hammond-Tooke GD, McCrory PR. Normative values for three clinical measures of motor performance used in the neurological assessment of sports concussion. *J Sci Med Sport*. 2010;13(2):196-201.
32. Schneiders AG, Sullivan SJ, McCrory PR, Gray AR, Maruthayanar S, Singh P, et al. The effect of exercise on motor performance tasks used in the neurological assessment of sports related concussion. *Br J Sports Med*. 2008;42(12):1011-3.

33. Onate JA, Beck BC, Van Lunen BL. On-field testing environment and Balance Error Scoring System performance during preseason screening of healthy collegiate baseball players. *J Athl Train.* 2007;42(4):446-51.
34. Ozinga SJ, Linder SM, Koop MM, Dey T, Figler R, Russman AN, et al. Normative performance on the Balance Error Scoring System by youth, high school, and collegiate athletes. *J Athl Train.* 2018;53(7):636-45.
35. McCrea M, Guskiewicz K, Randolph C, Barr WB, Hammeke TA, Marshall SW, et al. Incidence, clinical course, and predictors of prolonged recovery time following sport-related concussion in high school and college athletes. *J Int Neuropsychol Soc.* 2013;19(1):22-33.
36. McCrea M, Guskiewicz KM, Marshall SW, Barr W, Randolph C, Cantu RC, et al. Acute effects and recovery time following concussion in collegiate football players: the NCAA Concussion Study. *JAMA.* 2003;290(19):2556-63.
37. Riemann BL, Guskiewicz KM. Effects of mild head injury on postural stability as measured through clinical balance testing. *J Athl Train.* 2000;35(1):19-25.
38. Guskiewicz KM, Ross SE, Marshall SW. Postural stability and neuropsychological deficits after concussion in collegiate athletes. *J Athl Train.* 2001;36(3):263-73.
39. Riemann BL, Guskiewicz KM, Shields EW. Relationship between clinical and forceplate measures of postural stability. *J Sport Rehabil.* 1999;8(2):71-82.

40. Bell DR, Guskiewicz KM, Clark MA, Padua DA. Systematic review of the Balance Error Scoring System. *Sports Health*. 2011;3(3):287-95.
41. Hunt TN, Ferrara MS, Bornstein RA, Baumgartner TA. The reliability of the modified Balance Error Scoring System. *Clin J Sport Med*. 2009;19(6):471-5.
42. Erkmén N, Taşkın H, Kaplan T, Sanioglu A. The effect of fatiguing exercise on balance performance as measured by the balance error scoring system. *Isokinet Exerc Sci*. 2009;17(2):121-7.
43. McLeod TC, Armstrong T, Miller M, Sauers JL. Balance improvements in female high school basketball players after a 6-week neuromuscular-training program. *J Sport Rehabil*. 2009;18(4):465-81.
44. McLeod TCV, Barr WB, McCrea M, Guskiewicz KM. Psychometric and measurement properties of concussion assessment tools in youth sports. *J Athl Train*. 2006;41(4):399.
45. McLeod TCV, Perrin DH, Guskiewicz KM, Shultz SJ, Diamond R, Gansneder BM. Serial administration of clinical concussion assessments and learning effects in healthy young athletes. *Clin J Sport Med*. 2004;14(5):287-95.
46. Susco TM, McLeod TCV, Gansneder BM, Shultz SJ. Balance recovers within 20 minutes after exertion as measured by the Balance Error Scoring System. *J Athl Train*. 2004;39(3):241.
47. Finnoff JT, Peterson VJ, Hollman JH, Smith J. Intrarater and interrater reliability of the Balance Error Scoring System (BESS). *PM R*. 2009;1(1):50-4.

48. Cushman D, Hendrick J, Teramoto M, Fogg B, Bradley S, Hansen C. Reliability of the balance error scoring system in a population with protracted recovery from mild traumatic brain injury. *Brain Inj.* 2018;32(5):569-74.
49. Murray N, Salvatore A, Powell D, Reed-Jones R. Reliability and validity evidence of multiple balance assessments in athletes with a concussion. *J Athl Train.* 2014;49(4):540-9.
50. Iverson GL, Koehle MS. Normative data for the modified balance error scoring system in adults. *Brain Inj.* 2013;27(5):596-9.
51. Snedden TR, Brooks MA, Hetzel S, McGuine T. Normative Values of the Sport Concussion Assessment Tool 3 (SCAT3) in High School Athletes. *Clin J Sport Med.* 2017;27(5):462-7.
52. Hansen C, Cushman D, Anderson N, Chen W, Cheng C, Hon SD, et al. A normative dataset of the balance error scoring system in children aged between 5 and 14. *Clin J Sport Med.* 2016;26(6):497-501.
53. Chin EY, Nelson LD, Barr WB, McCrory P, McCrea MA. Reliability and validity of the Sport Concussion Assessment Tool-3 (SCAT3) in high school and collegiate athletes. *Am J Sports Med.* 2016;44(9):2276-85.
54. Putukian M, Echemendia R, Dettwiler-Danspeckgruber A, Duliba T, Bruce J, Furtado JL, et al. Prospective clinical assessment using Sideline Concussion Assessment Tool-2 testing in the evaluation of sport-related concussion in college athletes. *Clin J Sport Med.* 2015;25(1):36-42.

55. King LA, Horak FB, Mancini M, Pierce D, Priest KC, Chesnutt J, et al. Instrumenting the balance error scoring system for use with patients reporting persistent balance problems after mild traumatic brain injury. *Arch Phys Med Rehabil.* 2014;95(2):353-9.
56. Kleffelgaard I, Langhammer B, Sandhaug M, Pripp AH, Sørberg HL. Measurement properties of the modified and total Balance Error Scoring System—the BESS, in a healthy adult sample. *Eur J Physiother.* 2018;20(1):25-31.
57. Wilkins JC, Valovich McLeod TC, Perrin DH, Gansneder BM. Performance on the Balance Error Scoring System decreases after fatigue. *J Athl Train.* 2004;39(2):156-61.
58. Buckley TA, Munkasy BA, Clouse BP. Sensitivity and Specificity of the Modified Balance Error Scoring System in Concussed Collegiate Student Athletes. *Clin J Sport Med.* 2018;28(2):174-6.
59. Cross M, Kemp S, Smith A, Trewartha G, Stokes K. Professional Rugby Union players have a 60% greater risk of time loss injury after concussion: a 2-season prospective study of clinical outcomes. *Br J Sports Med.* 2016;50(15):926-31.
60. Lynall RC, Mauntel TC, Padua DA, Mihalik JP. Acute lower extremity injury rates increase after concussion in college athletes. *Med Sci Sports Exerc.* 2015;47(12):2487-92.
61. Nordstrom A, Nordstrom P, Ekstrand J. Sports-related concussion increases the risk of subsequent injury by about 50% in elite male football players. *Br J Sports Med.* 2014;48(19):1447-50.

62. Pietrosimone B, Golightly YM, Mihalik JP, Guskiewicz KM. Concussion frequency associates with musculoskeletal injury in retired NFL players. *Med Sci Sports Exerc.* 2015;47(11):2366-72.
63. Makdissi M, Schneider KJ, Feddermann-Demont N, Guskiewicz KM, Hinds S, Leddy JJ, et al. Approach to investigation and treatment of persistent symptoms following sport-related concussion: a systematic review. *Br J Sports Med.* 2017;51(12):958-68.
64. Brooks MA, Peterson K, Biese K, Sanfilippo J, Heiderscheid BC, Bell DR. Concussion increases odds of sustaining a lower extremity musculoskeletal injury after return to play among collegiate athletes. *Am J Sports Med.* 2016;44(3):742-7.
65. Burman E, Lysholm J, Shahim P, Malm C, Tegner Y. Concussed athletes are more prone to injury both before and after their index concussion: a data base analysis of 699 concussed contact sports athletes. *BMJ Open Sport Exerc Med.* 2016;2(1):e000092.
66. Hägglund M, Waldén M, Ekstrand J. Previous injury as a risk factor for injury in elite football: a prospective study over two consecutive seasons. *Br J Sports Med.* 2006;40(9):767-72.
67. Herman DC, Jones D, Harrison A, Moser M, Tillman S, Farmer K, et al. Concussion may increase the risk of subsequent lower extremity musculoskeletal injury in collegiate athletes. *Sports Med.* 2017;47(5):1003-10.
68. Gilbert FC, Burdette GT, Joyner AB, Llewellyn TA, Buckley TA. Association between concussion and lower extremity injuries in collegiate athletes. *Sports Health.* 2016;8(6):561-7.

69. Howell DR, Lynall RC, Buckley TA, Herman DC. Neuromuscular control deficits and the risk of subsequent injury after a concussion: a scoping Review. *Sports Med.* 2018;48(5):1097-115.
70. McPherson AL, Nagai T, Webster KE, Hewett TE. Musculoskeletal injury risk after sport-related concussion: a systematic review and meta-analysis. *Am J Sports Med.* 2018;47(7):1754-62.
71. Emery CA, Kang J, Shrier I, Goulet C, Hagel BE, Benson BW, et al. Risk of injury associated with body checking among youth ice hockey players. *JAMA.* 2010;303(22):2265-72.
72. Emery CA, Kang J, Schneider KJ, Meeuwisse WH. Risk of injury and concussion associated with team performance and penalty minutes in competitive youth ice hockey. *Br J Sports Med.* 2011;45(16):1289-93.
73. Emery C, Kang J, Shrier I, Goulet C, Hagel B, Benson B, et al. Risk of injury associated with bodychecking experience among youth hockey players. *CMAJ.* 2011;183(11):1249-56.
74. Zemper ED. Two-year prospective study of relative risk of a second cerebral concussion. *Am J Phys Med Rehabil.* 2003;82(9):653-9.
75. Guskiewicz KM, McCrea M, Marshall SW, Cantu RC, Randolph C, Barr W, et al. Cumulative effects associated with recurrent concussion in collegiate football players: the NCAA Concussion Study. *JAMA.* 2003;290(19):2549-55.

- 76.Hollis SJ, Stevenson MR, McIntosh AS, Shores EA, Collins MW, Taylor CB. Incidence, risk, and protective factors of mild traumatic brain injury in a cohort of Australian nonprofessional male rugby players. *Am J Sports Med.* 2009;37(12):2328-33.
- 77.Schneider KJ, Meeuwisse WH, Kang J, Schneider GM, Emery CA. Preseason reports of neck pain, dizziness, and headache as risk factors for concussion in male youth ice hockey players. *Clin J Sport Med.* 2013;23(4):267-72.
- 78.Slobounov SM, Sebastianelli WJ, editors. *Foundations of sport-related brain injuries.* New York: Springer Science & Business Media; 2006. Chapter 2: Aerobic fitness and concussion outcomes in high school football;p. 315-39.
- 79.Abrahams S, Fie SM, Patricios J, Posthumus M, September AV. Risk factors for sports concussion: an evidence-based systematic review. *Br J Sports Med.* 2014;48(2):91-7.
- 80.Tremblay S, de Beaumont L, Lassonde M, Theoret H. Evidence for the specificity of intracortical inhibitory dysfunction in asymptomatic concussed athletes. *J Neurotrauma.* 2011;28(4):493-502.
- 81.Marshall S, Bayley M, McCullagh S, Velikonja D, Berrigan L. Clinical practice guidelines for mild traumatic brain injury and persistent symptoms. *Can Fam Physician.* 2012;58(3):257-67, e128-40.

CHAPTER 2– GAIT DEVIATIONS ASSOCIATED WITH CONCUSSION: A SYSTEMATIC REVIEW

A version of this chapter has been published. Manaseer TS, Gross DP, Dennett L, Schneider K, et al. Gait Deviations Associated With Concussion: A Systematic Review [published online ahead of print, 2017 Nov 21]. Clin J Sport Med. 2017;10.1097/JSM.0000000000000537.

ABSTRACT

Background: Gait deviations resulting from concussion are important to consider in the diagnosis, treatment progression, and return to activity after a concussion. Objective: To identify quantifiable gait deviations associated with concussion across populations and time since injury.

Methods and Materials: Six electronic databases were systematically searched from January 1974 to September 2016. Studies selected included original data, had an analytic design, and reported a quantifiable gait parameter in individuals who had sustained a concussion as defined by the American Congress of Rehabilitation Medicine or related definitions. Preferred Reporting Items for Systematic reviews and Meta-Analysis guidelines were followed. Two independent authors assessed study quality [Downs and Black (DB) criteria] and level of evidence (Oxford Center of Evidence-Based Medicine Model).

Results: Of 2650 potentially relevant articles, 21 level 4 studies were included. The median DB score was 12/33 (range 10- 16). Heterogeneity in gait parameters and timing of post-concussion testing precluded meta-analysis. There is consistent level 4 evidence of increased medial-lateral

center-of-mass displacement, and inconsistent level 4 evidence of decreased gait velocity after concussion. Further, there is preliminary level 4 evidence that gait deficits may exist beyond the typical 10-day recovery period and return to activity.

Conclusion: These findings suggest that individuals who have suffered a concussion may sway more in the frontal plane, and walk slower compared to healthy controls. Consensus about the most important gait parameters for concussion diagnosis and clinical management are lacking. Further, high-quality prospective cohort studies evaluating changes in gait from time of concussion to return to activity, sport, recreation and/or work are needed.

2.1 INTRODUCTION

Concussion is the most frequent subtype of mild traumatic brain injury (mTBI).[1] The World Health Organization's (WHO) Collaborating Centre Task Force on mTBI estimates that the annual incidence of concussion is 100 to 300/100,000 emergency department visits.[1] However, as many concussions go unreported, it is estimated that the true annual incidence of concussion may be closer to 600/100 000.[1] Concussion is most prevalent in adolescents and young adult males, and is commonly attributed to sport participation, motor vehicle collision, and/or falls.[1]

A concussion is defined as a sequela of pathophysiological events that affect the brain as a result of a direct or indirect trauma to the head.[2] Concussions are not associated with alterations on standard structural imaging but can result in a vast range of acute neurophysiological signs and a multitude of symptoms that may persist for differing lengths of time.[2] Common short-term signs and symptoms include physical (e.g., imbalance, loss of consciousness, or gait unsteadiness) and neurocognitive (e.g., effected memory or reaction time) manifestations, sleep disturbance, and behavioral changes (e.g., irritability).[2] Possible long-term consequences of concussion include cognitive impairments,[3] altered postural control,[4] gait impairment,[5] and increased risk of musculoskeletal injury.[6]

Concussion diagnosis is multidimensional and involves the assessment of physical (e.g., loss of consciousness) and somatic symptoms (e.g., headache), cognition (e.g., reaction time), sleep quality, behavior (e.g., irritability), and postural control.[2] The American Congress of Rehabilitation Medicine (ACRM) has defined clinical criteria that are widely accepted and used in the field of neurophysiology and rehabilitation to diagnose concussion.[7] Similar guidelines

have been developed by the American Academy of Neurology (AAN),[7] the Consensus Statement on Concussion in Sport (CISG),[2] and the National Athletic Training Association (NATA; see Table 1).[8]

One functional task that is commonly used to assist in concussion diagnosis, treatment progression, or return to activity, sport, recreation and/or work decisions is gait. Gait is defined as “a method of locomotion involving the use of the two legs, alternately, to provide both support and propulsion”.[9] Gait can be evaluated using self-report, qualitative (e.g., rating of functional compensations, asymmetries, impairments or efficiency) or quantitative (e.g., objective measurement of gait with tools such as motion analysis) methods.[10] Self-report and qualitative evaluation techniques are inherently subjective and may result in inaccurate diagnosis, treatment, or return to activity, sport, recreation, and/or work decisions.[10] Conversely, quantitative gait assessment techniques enable the consideration of a variety of parameters and provide a more robust and reliable basis for diagnosis and decision-making.[10]

To date, most research examining the influence of concussion on gait has employed laboratory motion capture analysis systems to examine differences in kinematics and kinetics between individuals who have suffered a concussion and those who have not.[11, 12] These investigations have utilized single (e.g., gait alone) and/or dual (e.g., gait while conducting a mental task, avoiding obstacles, and/or responding to auditory stimuli) tasks and have been conducted at various intervals (e.g., 1, 2, 4, 8 weeks) post-concussion.[11, 12]

Although gait is commonly considered in the clinical assessment of concussion,[13] there is a lack of consensus regarding which gait parameters are the most important for concussion diagnosis or

to inform return to activity, sport, recreation and/or work decisions. The primary objective of this systematic review is to identify quantifiable gait deviations associated with concussion based on time since injury. The findings of this review will inform future research aimed at identifying which gait parameters are the most important to consider for clinical diagnosis of concussion and return to activity, sport, recreation and/or work decisions.

2.2 METHODS

This review was registered in the PROSPERO database (CRD 42016032529) and conducted according to the Preferred Reporting Items for Systematic reviews and Meta- Analysis (PRISMA) guidelines.[14]

2.2.1 Data Sources and Search

Six electronic databases [MEDLINE, CINAHL (Cumulative Index to Nursing and Allied Health Literature), Sport Discus, SCOPUS, EMBASE (Excerpta medical database) and PsycINFO] were searched from January 1, 1974 (Glasgow Coma Scale development) to September 29, 2016 to identify relevant studies.[15] The combination of medical subject headings (MeSH) and text words used to execute the literature search was developed in consultation with a librarian scientist (LD). Appendix 1 outlines the search term combinations for each database. Limits included; English or Arabic language, human participants and analytical concussion studies published in peer-reviewed journals. Returned articles were organized using the reference management software package RefWorks (ProQuest, 2016). The number of articles obtained from each search strategy by database was recorded and a running total constructed. After removing duplicate articles, the titles and corresponding abstracts of all returned articles were independently reviewed by two of the

authors (TM and DG or JW) blinded to journal title and author(s) using a Microsoft Excel workbook designed specifically for screening.[16] Data were compiled and consensus on items for which there was disagreement was reached through rater discussion. Prior to title and abstract review all authors independently screened a random sample of 120 titles and abstracts and reached a strong agreement with the lead author (probability of random agreement = 0.82, Cohen's Kappa = 0.91) using the same excel workbook.[16] Finally, two authors (TM and DG or JW) reviewed the full text of all potentially relevant studies to determine final study selection. Disagreements were resolved via author consensus. During the full text review, the reference lists of all potentially relevant articles were hand-searched to identify any potentially relevant studies that had not been identified in the database search.

2.2.2 Study Selection

Studies were included if they represented primary research published in peer-reviewed journals, analytical study design, and contained original data that investigated the association between a quantifiable gait parameter (e.g., step, stride, center of mass parameters) and concussion as defined according to one of the AAN, ACRM, CISG, or NATA criteria (Table 1). Studies were excluded if they involved: participants with moderate or severe TBI (e.g., involved brain hemorrhage, skull fracture, neuroimaging abnormality, or open head injury), or brain pathology (e.g., cardiovascular accident/stroke), animal models or cadavers. Further, reviews articles, meta-analyses, case studies, case series, editorials, commentaries, opinion based papers and conference proceedings were excluded.

2.2.3 Data Extraction and Study Rating Process

Data extracted from each study included: study year, design (repeated or non-repeated measures), location, population (age, sex, athletic vs nonathletic, symptomatic vs non-symptomatic, and sample size); concussion definition; gait parameters assessed; tasks performed; timing of post-concussion testing (hours, days, weeks, years, or a point after return to physical activity or play) and results (point estimates and measures of variability) where available. The first author (T.S.M.) performed the initial data extraction, and data accuracy was ensured by D.P.G. and J.L.W. Data extraction disagreements were resolved by author consensus.

Two authors (T.S.M. and D.P.G. or J.L.W.) independently evaluated the quality and level of evidence of each study. Quality of evidence was assessed based on criteria for internal validity (study design, quality of reporting, presence of selection and misclassification bias, potential confounding) and external validity (generalizability) using the Downs and Black (DB) quality assessment tool.[17] This tool assigns a score calculated out of 32 points (11 points for reporting, 3 points for external validity, 7 points for bias, 6 points for confounding and 5 for power) for each study. The level of evidence represented for each study was categorized according to the Oxford Centre of Evidence Based Medicine (OCEBM) model.[18] Disagreements in DB and OCEBM rating were resolved by rater consensus.

2.2.4 Data Synthesis

The quantity, quality, and level of evidence for the most commonly investigated gait parameters across 3 time periods (i.e., less than or equal to the typical 10-day post-concussion recovery period, greater than the typical 10-day post-concussion recovery period and after return to any activity including physical activity, sport and work) were collated. A cut-point of 10 days post-concussion

was used as it has previously been reported that 80% to 90% of concussed individuals recover within 7 to 10-day post-injury.[2]

2.3 RESULTS

2.3.1 Identification of Studies

An overview of the study identification process is shown in Figure 1 and Appendix 2 summarizes the identification of unique articles by database. The initial search yielded 2650 articles, 1187 duplicates were removed leaving 1463 potentially relevant articles. After the removal of studies not meeting inclusion criteria based on title and abstract reviews, this number was reduced to 92. One hundred and thirty-nine studies were excluded on study design (9 case studies, 15 case reports, 10 case series, 8 commentaries, 7 editorials, 7 book chapters, 7 abstracts, 42 reviews, 2 meta-analysis, 31 conference proceedings, 1 survey), 721 did not fit the criteria for concussion, 3 only reported subjective outcomes, 265 did not investigate the association between concussion and gait, and 243 involved animal models. Subsequent to full article screening, 71 studies were excluded leaving 21 studies deemed appropriate for inclusion to the systematic review. No additional articles were identified through reference list searches. Meta-analyses were precluded due to the heterogeneity of investigated gait parameters and timing of post-concussion testing (see columns 4 and 5 in Table 2).

2.3.2 Study Characteristics

Characteristics of the 21 included studies are summarized in Table 2.[13, 19-38] The 21 studies were published between 2005 and 2016. Nineteen of the 21 studies were conducted in the US, with

the remaining 2 taking place in Canada and Norway.[25, 29] Six of the 21 studies were cross-sectional in nature,[19, 27, 29, 34, 35, 38] while the remaining incorporated repeated measures. The total number of participants assessed across studies was 1120. Participants ranged in age from 5 to 53 years and included 675 males and 342 females (2 studies did not report participant sex). Fourteen (66%) of the studies investigated gait parameters in athletes,[19-23, 25-27, 31-33, 35, 37, 38] four (19%) considered high school and/or college students described as being involved in athletic-like activities,[24, 28, 34, 35] two considered adults,[29, 30] and 1 did not describe the source population.[13] Concussion was defined according to the AAN criteria in 11 studies (52%),[25, 27, 30-38] the CISG criteria in nine studies (43%),[13, 19-24, 26, 28] and the ACRM criteria in one study.[29] None of the included studies provided sufficient information to determine if participants were symptomatic or if they had been medically cleared to return to sport at the time of testing.

A variety of different gait tasks were used across the included studies. The majority (18/21) of studies used either a single [19-21, 23-31, 33-38] and/or a dual gait task (17/21),[13, 19, 21-24, 27, 28, 30-38] while four used an obstacle crossing task.[27, 31, 32, 35] The most commonly investigated gait parameters included gait velocity (GV; 15 studies),[13, 19, 20, 24-29, 33-38] center-of-mass displacement (COMD; 13 studies),[21-24, 28, 30, 31, 33-38] and center-of-mass velocity (COMV; 13 studies).[21-24, 28, 30, 31, 33-38] Other gait parameters assessed included center-of-mass, center-of- pressure separation (COM-COPS), [30, 31, 33-38] step width (STW),[25, 28, 34, 35, 37, 38] stride length (SL),[19, 34, 35, 37, 38] stride time (SRT),[34, 35, 37, 38] step length (STL),[25, 28] propulsive and braking forces percentage,[26] trunk roll angle and swing time,[25] lateral dynamic stability margin,[25] and obstacle-foot clearance.[32] Most

(19/21) of the included studies gathered kinematic and kinetic gait parameters using a traditional motion analysis system while two of the studies employed wearable technology (gait analysis sensors).[13, 19] The median interval between concussion and gait assessment across studies was 14 days (range 24 hours to 4 years). Sixteen studies reported gait deviations within the typical 10-day post-concussion recovery period,[13, 19, 20, 22, 24, 26-28, 30, 31, 33-38] Ten reported deviations after the typical 10-day post-concussion recovery period,[13, 22-24, 28, 30, 31, 33, 36, 37] and three reported deviations after return to activity.[21, 23, 29] The majority (18/21) of the included studies compared concussed individuals and match healthy controls, while three studies,[20, 21, 29] used baseline measures for comparison. Of the 21 included studies, two reported the clinometric properties of the measurement system employed in their investigation,[19, 29] and two studies reported the diagnostic accuracy (sensitivity and/or specificity) of gait parameters (i.e., GV and COM deviations) to differentiate between individuals who have suffered a concussion and those who have not.[13, 20]

2.3.3 Study Quality and Level of Evidence

The highest level of evidence demonstrated by the included studies as per the OCEMB levels of evidence model was level 4, corresponding to cross-sectional or case control studies, or poor quality prognostic cohort study. Based on the DB criteria, the median methodological quality rating for the included studies was 12/33 (range 10- 16). The DB is designed to evaluate the methodological quality of a scientific study and can be applied to both interventional and observational studies. As all of the included studies were observational in nature, 7 items (4, 8, 14, 19, 23, 24, and 27) totaling 10 points on the DB checklist were not applicable. The most consistent methodological weaknesses of the included studies included: a limited description of the principal

confounders (e.g., concussion modifiers), insufficient information upon which to determine how the study sample was representative of the population of interest (i.e., how the individuals who chose to participate differ from those who did not), inadequate sample size, and insufficient description of the validity and reliability of the measurement systems employed.

2.3.4 Synthesis of Results

Table 3 summarizes the quantity, quality and level of evidence of the most frequently investigated gait parameters within the typical 10-day post-concussion recovery period, beyond the typical 10-day post-concussion recovery period, and after return to activity. Within the typical 10-day post-concussion recovery period there is a moderate amount of consistent level 4 evidence of increased M–L COMD; a moderate amount of inconsistent level 4 evidence of decreased GV, A–P COMV, and disturbed (i.e., increased or decreased) M–L COMV and COM-COPS; and a small amount of inconsistent level 4 evidence of step and stride parameter alterations. Further, there is preliminary level 4 evidence that suggests that some of these gait deviations (i.e., decreased GV and increased M–L COMD and M–L COMV) exist, and therefore may persist, beyond the typical 10-day post-concussion recovery period, and after return to activity, sport, recreation, or work.[21, 23, 29]

2.4 DISCUSSION

To our knowledge, this is the first systematic review to identify and summarize quantifiable gait deviations associated with concussion that has incorporated both a formal evaluation of study quality and level of evidence. Although there is a lack of consensus about the most important gait parameters to assess after concussion, the current results suggest that concussed individuals sway more in the frontal plane (consistent level 4 evidence), and may walk slower (inconsistent level 4

evidence) compared with healthy controls within the typical 10-day post-concussion recovery period. Further, there is limited preliminary level 4 evidence that for some individuals, these deficits exist, and therefore may persist, beyond the typical 10-day post-concussion recovery period and return to activity. No studies were identified that assessed gait parameters to inform return to activity, sport, recreation, or work decisions. Further, few studies have assessed the association concussion and gait parameters in nonathletic populations.

It is important to highlight that the findings of this review are based upon an evaluation and synthesis of the existing literature and are limited by the design of the studies included. Overall there was a lack of high-quality evidence. The biggest threats to internal validity identified were related to selection bias, and the reporting and adjustment for potential confounding by factors such as preexisting gait deviations, the heterogenous nature of concussion (e.g., not all individuals who suffer a concussion may develop gait deviations), presence or absence of symptoms, medication use, sleep disorder, and style of play. Similarly, there was potential for measurement bias across studies due to insufficient operationalization of many gait parameters and a lack of information about the measurement properties (e.g., validity, reliability, resolution) of the measurement systems employed. In addition to limiting internal validity, the inability to assess for selection bias limits the degree to which the results of these studies can be generalized to the larger population from which the samples were drawn (external validity). The external validity of the results is brought further into question by the fact that 18(86%) of the studies included athletes or those who were involved in athletic-like activities. Further, as 15 (71%) included studies had sample sizes less than 50 participants (inclusive of concussed and healthy controls), and only 1

study had a sample size greater than 100,[20] it is possible that some of the included studies were inadequately powered to detect effects and overestimate the reported effect sizes.[39]

Another consideration is the lack of information justifying the time points chosen for post-concussion follow-up gait testing. To improve the clinical utility of future studies it is suggested that investigators consider a follow-up gait-testing schedule based on commonly accepted concussion recovery stages. For instance, the CIGS, report that 80% to 90% of individuals who sustain a concussion recover within 7 to 10 days.[2] Further, it is recommended that concussed individuals should progress through a Graded Return to Physical Activities Protocol (GRTPP) before being fully cleared to participate in physical activities (Full Clearance). This approach will improve our understanding of gait during each of the concussion recovery stages, and the utility of gait analysis as a concussion recovery measure.

The findings of the current review build upon a previous meta-analysis that examined the utility of a dual-task paradigm (DT) for sports-related concussion gait assessment,[40] that reported decreased GV[pooled mean difference (95%CI); 20.133 m/s (20.197 to 20.069)] and greater M–L COMD [0.007m(0.002-0.011)] 2 days post-concussion, and decreased M–L COMV at 6 [0.014 m/s, (0.003-0.026)] and 28 [0.013m/s (0.003-0.023)] days post-concussion. Taken together, the findings of this and the previous review suggest that concussed individuals may initially adopt a conservative approach to gait which involves walking slower and keeping their COM closer to their base of support (i.e., COP) which increases their M–L sway. This gait pattern is similar to that reported amongst other populations with a high risk of falling (e.g., moderate to severe traumatic brain injuries and elderly).[41, 42] These findings have implications for clinical tests designed to assess and detect gait disturbances in individuals who have suffered a concussion.

Specifically, a clinical test should include an assessment of GV and M–L sway to be sensitive to gait disturbances that may occur after concussion. The most common clinical test of gait in concussed patients is the Tandem Gait Test (TGT).[43] This test involves walking in a forward direction as quickly and as accurately as possible along a 38-mm wide, three-meter line and back, with an alternate foot heel-to-toe gait. The total time it takes to complete the task, the ability to stay on the line, and avoid separation of their heel and toe while maintaining posture are noted. Although rudimentary, the TGT does include a component of GV (distance 3 time) and M–L sway (ability to walk on a line). With that said, the diagnostic accuracy of the TGT for detecting gait disturbance is unknown, as concussed athletes have been shown to complete the test faster than non-concussed athletes.[44]

A novel finding of this review is that concussion-associated gait deficits, including decreased GV and increased M–L COMD and M–L COMV exist, and therefore may possibly persist beyond the typical 10-day recovery period after concussion, and after return to activity, sport, recreation, and work. The persistence of gait disturbances beyond return to activity, sport, and recreation may place an athlete at increased risk of future injury. This hypothesis is supported by initial evidence from professional rugby that demonstrates a 60% higher incidence of injury in players after concussion {incidence ratio rate [95% CI, 1.6 (1.4-1.8)]} compared with players who did not suffer a concussion.[45] Further, that, the median time to injury after return to sport was shorter among players who suffered a concussion [53 days (95% CI, 41-46)] than players who did not [114 days (95% CI, 85-143)]. Further investigation of the relationship between concussion related gait deficits and injury risk in the post-concussion return to activity, sport, recreation, and work period is required.

2.4.1 Limitations

Meta-analyses were not possible due to the heterogeneity of gait parameters assessed, and variable timing of post-concussion gait analysis. Despite a comprehensive search strategy, and the rigorous approach to study selection and data extraction, it is important to acknowledge the possibility of omitting a relevant study and inclusion of only Arabic and English language studies as additional potential limitations. As the findings of this review are based on the existing literature, it is important to consider that not all possibly relevant gait parameters may have been considered. Further, it is important to highlight that the associations between concussion and various gait parameters identified in this review are based on level 4 evidence with a high risk of bias, and given that 76% of the included studies were performed by three research teams the findings may lack external validity (i.e., generalizability). Finally, it is important to acknowledge that the findings related to the existence of gait deviations after the typical 10-day post-concussion recovery period and return to activity are based on a smaller number of investigations.

2.4.2 Recommendations

There is a need for high-quality prospective studies with sufficient sample sizes spanning the preinjury through to concussion and return to activity, sport, recreation, and/or work, and beyond. This research should use a definition for concussion that is consistent with the AAN, ACRM, CISG, or NATA criteria, and consider quantifying gait parameters that appear to be the most useful for detecting gait deficits post-concussion (i.e., GV and M–L COMD) within the first 10 days after concussion and at the time of symptom resolution, the start of graded activity or GRTPP, and at full clearance to return to activity, sport, recreation, and/or work. Further, there is a need for studies

examining the association between concussion and gait across nonathletic populations. Finally, from a clinical perspective, there is a need for a dynamic postural control assessment tool that is capable of detecting gait disturbances in concussed individuals in field settings. Ideally, this tool would challenge an individual's GV and M-L COMD under complex physical tasks (ie, walking, sport, and/ or work-specific tasks) with and without secondary cognitive demands to better understand alterations that may occur.

2.5 CONCLUSION

Individuals who have suffered a concussion may sway more in the frontal plane (consistent level 4 evidence), and walk slower (inconsistent level 4 evidence) compared to healthy controls within the typical 10-day post-concussion recovery period. Further, there is preliminary level 4 evidence that for some individuals, these deficits exist, and therefore may possibly persist, beyond the typical 10-day post-concussion recovery period and return to activity. There is a paucity of information about the role that gait parameters might have in informing return to activity, sport, recreation, or work decisions, and the current level of evidence is threatened by a risk of bias. Future research should include high-quality prospective studies spanning the period from concussion through return to activity and beyond to better understand the natural course of gait alterations after concussion across diverse populations.

2.6 REFERENCES

1. Cassidy JD, Carroll LJ, Peloso PM, Borg J, von Holst H, Holm L, et al. Incidence, risk factors and prevention of mild traumatic brain injury: results of the WHO Collaborating Centre Task Force on Mild Traumatic Brain Injury. *J Rehabil Med.* 2004;36(43 Suppl):28-60.
2. McCrory P, Meeuwisse WH, Aubry M, Cantu RC, Dvorak J, Echemendia RJ, et al. Consensus statement on concussion in sport--the 4th International Conference on Concussion in Sport held in Zurich, November 2012. *PM R.* 2013;5(4):255-79.
3. Guskiewicz KM, Marshall SW, Bailes J, McCrea M, Cantu RC, Randolph C, et al. Association between recurrent concussion and late-life cognitive impairment in retired professional football players. *Neurosurgery.* 2005;57(4):719-26.
4. De Beaumont L, Mongeon D, Tremblay S, Messier J, Prince F, Leclerc S, et al. Persistent motor system abnormalities in formerly concussed athletes. *J Athl Train.* 2011;46(3):234-40.
5. Pan T, Liao K, Roenigk K, Daly JJ, Walker MF. Static and dynamic postural stability in veterans with combat-related mild traumatic brain injury. *Gait Posture.* 2015;42(4):550-7.
6. Pietrosimone B, Golightly YM, Mihalik JP, Guskiewicz KM. Concussion frequency associates with musculoskeletal injury in retired NFL players. *Med Sci Sports Exerc.* 2015;47(11):2366-72.
7. Ruff RM, Iverson GL, Barth JT, Bush SS, Broshek DK, Policy NAN, et al. Recommendations for diagnosing a mild traumatic brain injury: a National Academy of Neuropsychology education paper. *Arch Clin Neuropsychol.* 2009;24(1):3-10.

8. Broglio SP, Cantu RC, Gioia GA, Guskiewicz KM, Kutcher J, Palm M, et al. National Athletic Trainers' Association position statement: management of sport concussion. *J Athl Train.* 2014;49(2):245-65.
9. Kharb A, Saini V, Jain Y, Dhiman S. A review of gait cycle and its parameters. *IJCEM.* 2011;13:78-83.
10. Muro-de-la-Herran A, Garcia-Zapirain B, Mendez-Zorrilla A. Gait analysis methods: an overview of wearable and non-wearable systems, highlighting clinical applications. *Sensors.* 2014;14(2):3362-94.
11. Catena RD. Attention and gait performance following a concussion [dissertation]. University of Oregon; 2008.
12. Fino PC. A preliminary study of longitudinal differences in local dynamic stability between recently concussed and healthy athletes during single and dual-task gait. *J Biomech.* 2016;49(9):1983-8.
13. Howell D, Osternig L, Chou LS. Monitoring recovery of gait balance control following concussion using an accelerometer. *J Biomech.* 2015;48(12):3364-8.
14. Liberati A, Altman DG, Tetzlaff J, Mulrow C, Gøtzsche PC, Ioannidis JPA, et al. The PRISMA statement for reporting systematic reviews and meta-analyses of studies that evaluate health care interventions: explanation and elaboration. *J Clin Epidemiol.* 2009;62:e1-34.

15. Jennett B. Development of Glasgow coma and outcome scales. *Nepal Journal of Neuroscience*. 2005;2(1):24-8.
16. VonVille HM. Excel workbooks for systematic reviews [internet]. Texas: The University of Texas; 2015 [Accessed January 1, 2016]. Available from: http://libguides.sph.uth.tmc.edu/excel_workbook_home.
17. Downs SH, Black N. The feasibility of creating a checklist for the assessment of the methodological quality both of randomised and non-randomised studies of health care interventions. *J Epidemiol Community Health*. 1998;52(6):377-84.
18. Howick J, Phillips B, Ball C, et al. Oxford centre for evidence-based medicine: Levels of evidence 2009. Oxford Centre for Evidence-Based Medicine; 2009 [Accessed January 3, 2016]. Available at: <http://www.cebm.net/oxford-centre-evidence-based-medicine-levels-evidence-march-2009/>.
19. Howell DR, Beasley M, Vopat L, Meehan WP, 3rd. The effect of prior concussion history on dual-task gait following a concussion. *J Neurotrauma*. 2017;34(4):838-44.
20. Galetta KM, Morganroth J, Moehringer N, Mueller B, Hasanaj L, Webb N, et al. Adding vision to concussion testing: a prospective study of sideline testing in youth and collegiate athletes. *J Neuroophthalmol*. 2015;35(3):235-41.
21. Howell DR, Osternig LR, Christie AD, Chou L-S. Return to physical activity timing and dual-task gait stability are associated 2 months following concussion. *J Head Trauma Rehabil*. 2015.

22. Howell DR, Osternig LR, Chou LS. Adolescents demonstrate greater gait balance control deficits after concussion than young adults. *Am J Sports Med.* 2015;43(3):625-32.
23. Howell DR, Osternig LR, Chou LS. Return to activity after concussion affects dual-task gait balance control recovery. *Med Sci Sports Exerc.* 2015;47(4):673-80.
24. Howell DR, Osternig LR, Koester MC, Chou LS. The effect of cognitive task complexity on gait stability in adolescents following concussion. *Exp Brain Res.* 2014;232(6):1773-82.
25. Powers KC, Kalmar JM, Cinelli ME. Dynamic stability and steering control following a sport-induced concussion. *Gait Posture.* 2014;39(2):728-32.
26. Buckley TA, Munkasy BA, Tapia-Lovler TG, Wikstrom EA. Altered gait termination strategies following a concussion. *Gait Posture.* 2013;38(3):549-51.
27. Chiu SL, Osternig L, Chou LS. Concussion induces gait inter-joint coordination variability under conditions of divided attention and obstacle crossing. *Gait Posture.* 2013;38(4):717-22.
28. Howell DR, Osternig LR, Chou LS. Dual-task effect on gait balance control in adolescents with concussion. *Arch Phys Med Rehabil.* 2013;94(8):1513-20.
29. Kleffelgaard I, Roe C, Soberg HL, Bergland A. Associations among self-reported balance problems, post-concussion symptoms and performance-based tests: a longitudinal follow-up study. *Disabil Rehabil.* 2012;34(9):788-94.
30. Catena RD, van Donkelaar P, Chou LS. The effects of attention capacity on dynamic balance control following concussion. *J Neuroeng Rehabil.* 2011;8:8.

31. Catena RD, van Donkelaar P, Chou LS. Different gait tasks distinguish immediate vs. long-term effects of concussion on balance control. *J Neuroeng Rehabil.* 2009;6:25.
32. Catena RD, van Donkelaar P, Halterman CI, Chou LS. Spatial orientation of attention and obstacle avoidance following concussion. *Exp Brain Res.* 2009;194(1):67-77.
33. Parker TM, Osternig LR, van Donkelaar P, Chou LS. Balance control during gait in athletes and non-athletes following concussion. *Med Eng Phys.* 2008;30(8):959-67.
34. Catena RD, van Donkelaar P, Chou LS. Cognitive task effects on gait stability following concussion. *Exp Brain Res.* 2007;176(1):23-31.
35. Catena RD, van Donkelaar P, Chou L-S. Altered balance control following concussion is better detected with an attention test during gait. *Gait Posture.* 2007;25(3):406-11.
36. Parker TM, Osternig LR, van Donkelaar P, Chou LS. Recovery of cognitive and dynamic motor function following concussion. *Br J Sports Med.* 2007;41(12):868-73; discussion 73.
37. Parker TM, Osternig LR, P VAND, Chou LS. Gait stability following concussion. *Med Sci Sports Exerc.* 2006;38(6):1032-40.
38. Parker TM, Osternig LR, Lee HJ, Donkelaar P, Chou LS. The effect of divided attention on gait stability following concussion. *Clin Biomech (Bristol, Avon).* 2005;20(4):389-95.
39. Button KS, Ioannidis JP, Mokrysz C, Nosek BA, Flint J, Robinson ES, et al. Power failure: why small sample size undermines the reliability of neuroscience. *Nat Rev Neurosci.* 2013;14(5):365-76.

40. Lee H, Sullivan SJ, Schneiders AG. The use of the dual-task paradigm in detecting gait performance deficits following a sports-related concussion: a systematic review and meta-analysis. *J Sci Med Sport*. 2013;16(1):2-7.
41. Basford JR, Chou LS, Kaufman KR, Brey RH, Walker A, Malec JF, et al. An assessment of gait and balance deficits after traumatic brain injury. *Arch Phys Med Rehabil*. 2003;84(3):343-9.
42. Kaya BK, Krebs DE, Riley PO. Dynamic stability in elders: momentum control in locomotor ADL. *J Gerontol A Biol Sci Med Sci*. 1998;53(2):M126-34.
43. Schneiders AG, Sullivan SJ, Gray AR, Hammond-Tooke GD, McCrory PR. Normative values for three clinical measures of motor performance used in the neurological assessment of sports concussion. *J Sci Med Sport*. 2010;13(2):196-201.
44. Schneiders A, Sullivan S, Lee H, McCrory P. An evaluation of Tandem Gait as a measure of dynamic balance and coordination in the assessment of individuals with medical diagnosed sports-related concussion. *J Sci Med Sport*. 2013;16(e88):e88.
45. Cross M, Kemp S, Smith A, Trewartha G, Stokes K. Professional Rugby Union players have a 60% greater risk of time loss injury after concussion: a 2-season prospective study of clinical outcomes. *Br J Sports Med*. 2016;50(15):926-31.

2.7 TABLES

Table 2-1: Summary of Concussion Definition and Diagnosis Guidelines

Table 1: Summary of Concussion Definition and Diagnosis Guidelines

Organization	Concussion Definition and Diagnosis
AAN	Definition: A clinical syndrome of biomechanically induced alteration of brain function, typically affecting memory and orientation, which may involve LOC.
	Diagnosis based on
	Post-Concussion Symptom Scale or Graded Symptom Checklist.
	The Standardized Assessment of Concussion (SAC)
	Neuropsychological testing
	The Balance Error Scoring System
	The Sensory Organization Test

ACRM	Definition: A traumatically induced physiological disruption of brain function.
	Diagnosis based on
	Loss of consciousness (LOC)
	Loss of memory of immediately before or after an incident
	Alteration in mental state at the time of an incident (ie, dazed, disoriented, or confused)
	Focal neurologic deficits) where the injury severity does not exceed: LOC of ; #30 min; Glasgow Coma Scale (GCS) score of 13–15 at 30 min; Posttraumatic amnesia (PTA) not .24 h.
CIGS	Definition: A brain injury and is defined as a complex pathophysiological process affecting the brain, induced by biomechanical forces. It may be caused either by a direct blow to the head, face, neck or elsewhere on the body with an “impulsive” force transmitted to the head, and typically results in the rapid onset of short-lived impairment of neurologic function that resolves spontaneously. However, in some cases, symptoms and signs may evolve over a number of minutes to hours. Further, concussion may result in neuropathological changes, but the acute clinical

	<p>symptoms largely reflect a functional disturbance rather than a structural injury and, as such, no abnormality is seen on standard structural neuroimaging studies. Concussion results in a graded set of clinical symptoms that may or may not involve LOC. Resolution of the clinical and cognitive symptoms typically follows a sequential course. However, it is important to note that in some cases symptoms may be prolonged.</p>
	Diagnosis based on
	Symptoms—somatic (ie, headache), cognitive (ie, feeling like in a fog) and/or emotional symptoms (ie, irritability)
	Physical signs (ie, loss of consciousness, PTA)
	Behavioral changes (ie, irritability)
	Cognitive impairment (ie, slowed reaction times)
	Sleep disturbance (ie, insomnia)
NATA	Definition: Trauma-induced alteration in mental status that may or may not involve LOC.

	Diagnosis based on
	Clinical evaluation supported by assessment tools.
	A brief concussion-evaluation tool (ie, SAC) in conjunction with symptom and motor-control evaluation for rapid assessment.

Table 2-2: Systematic Review – Characteristics of Included Studies

Table 2: Characteristics of Included Studies						
Study (Year, Design Follow-Up, Country)	Participants (Description, Age, Sex, Symptoms, Sample Size)	Concussion Definition	Gait Outcome(s), Time Point(s), and Task(s)	Gait Outcome(s) Reported as Significantly Different With Concussion	Gait Outcome(s) Reported as Not Significantly Different With Concussion	DB
Howell et al [19]	Adolescent athletes	CISG [2]	Outcome(s): 1. Average gait speed (m/s); 2. Cadence (steps/min); 3. Double support time (% gait cycle); 4. Gait cycle duration; 5.Stride length (m)	5. Smaller stride length (≥ 2 concussions) walk + cognitive task (P = 0.010, d = 0.070)	1. Average gait speed; 2. Cadence; 3. Double support time; 4. Gait cycle duration	12
No repeated measures	Mean age (range): CONC: 16 (14-17) .1 CONC: 17 (15-18); CONT: 15 (14-16)		Time point(s): Within 14 days of concussion			
USA	Female: 68		Task(s): 1. Walking (self- selected speed); 2. Walk + cognitive task (spelling, counting, or reciting backwards)			
	n = 68 (37 concussions)					
Galetta et al [20]	Youth and collegiate athletes	CISG [2]	Outcome(s): 1. Timed Tandem gait(s)	1. Increased Tandem gait time (P = 0.020)	None	10

Repeated measures	Mean age (SD; range): CONC: Youth: 11 (3; 5-17); Collegiate: 20 (1; 18-23); CONT: Baseline data		Time point(s): 1. Pre-season; 2. At concussion			
USA	Female: 61; Male: 271		Task(s): 1. Walking as fast as possible			
	n = 332 (12 concussions)					
Howell et al [13]	Not reported	CISG [2]	Outcome(s): 1. GV (m/s); 2. Peak A-P acceleration (m/s ²); 3. Peak M-L acceleration (m/s ²)	1. Decreased GV at 72 h (P = 0.003), 1 wk (P = 0.013), 2 wks (P = 0.031); 3. Decreased peak M-L acceleration at weeks 1, 2, 4, 8 (F _{1,14} = 5.770, P = 0.040)	2. Peak A-P acceleration	12
Repeated measures	Mean age (SD; range); CONT 20: (4.5; 15-24); CONC: 19 (5.5; 14-25)		Time point(s): 72 h, 1, 2, 4, 8 wks post-concussion			
USA	Female: 7; Male: 10		Task(s): 1. Walk + MAS			
	n = 17 (10 concussions)					
Howell et al [21]	High school and collegiate athletes	CISG2	Outcome(s): 1. Total M-L COMD (cm); 2. Peak linear M-L COMV (cm/s); 3. Peak anterior COMV (cm/s)	1. Increased total M-L COMD during Walk + MAS (P = 0.004); 2. Increased peak M-L COMV during Walk + MAS (P = 0.048)	3. Peak anterior COMV	11
Repeated measures	Mean age (SD; range): CONC: 17 (2.9, 14-25); CONT: Baseline data		Time point(s): within 2 mo after return to			

			physical activities			
USA	Female: 8; Male: 21		Task(s): 1. Walk; 2. Walk + MAS			
	n = 29 (29 concussions)					
Howell et al [22]	High school & collegiate athletes.	CISG [2]	Outcome(s): 1. Total M-L COMD (m); 2. Anterior COMV (m/s); 3. M-L COMV (m/s)	1. Increased total M-L COMD at 72 h (F3,75 = 4.770, P = 0.004), and 1, 2, 4, 8 wks (F3,75 = 5.260, P = 0.002); 2. Decreased peak anterior COMV at 72 h (F3,75 = 8.360, P = 0.001); 3. Increased peak M-L COMV at 72 h (F3,75 = 5.760, P = 0.001), across 8 wks (F12,284 = 2.200, P = 0.012) and at 8 wks (P = 0.004)	None	16
Repeated measures	Mean age (SD; range): CONC (adult): 20 (2.4; 18-27); CONT (adolescent): 15 (1.1; 14-17); CON (adult): 20 (2.1; 18-26); CONT (adolescent): 16 (1.1; 14-17)		Time point(s): 72 h; 1, 2, 8 wks post-concussion			

USA	Female: 24; Male: 52		Task(s): 1. Walk + MAS			
	n = 76 (38 concussions)					
Howell et al [23]	Athletes	CISG [2]	Outcome(s): 1. M-L COMD; 2. Peak M-L COMV; 3. Peak anterior COMV	1. Increased M-L COMD during Walk + MAS (P = 0.002)	2. Peak M-L COMV; 3. Peak anterior COMV	13
Repeated measures	Mean age (SD; range): CONT: 16 (1.1; 15-17); CONC: 15 (1.4; 14-17)		Time point(s): 72 h; 1, 2, 4, 8 wks; Pre and post return to physical activities (within 2 mo)			
USA	Female: 6; Male: 32		Task(s): 1. Walk; 2. Walk + MAS			
	n = 38 (19 concussions)					
Howell et al [24]	High school students	CISG [2]	Outcome(s): 1. Total M-L COMD (m); 2. Peak anterior COMV (m/s); 3. Peak M-L COMV (m/s); 4. Average GV (m/s)	1. Increased total M-L COMD at 72 h, 1, 2, 4, 8 wks during Walk + MAS and Walk + Q& A (F3,129 = 5.310, P = 0.004)	2. Peak anterior COMV; 3. Peak M-L COMV; 4. Average GV	11
Repeated measures	Mean age (SD; range): CONT: 16 (1.3; 14-17); CONC: 15 (1.3; 14-17)		Time point(s): 72 h; 1, 2, 4, 8 wks post-concussion			
USA	Female: 6; Male: 40		Task(s): 1. Walk; 2. Walk + SAS; 3. Walk + MAS; 4. Walk + Q&A			

	n = 46 (23 concussions)					
Powers et al [25]	Collegiate athletes	AAN [7]	Outcome(s): 1. Step length (cm); 2. Step width (cm); 3. GV (cm/s); 4. Trunk roll angle (degrees); 5. Trunk swing time (s); 6. Minimum lateral dynamic stability margin (cm)	5. Increased swing time at acute phase (P = 0.009, Cohen's d = 1.400), at return to practice phase (P = 0.005, Cohen's d = 1.520); 6. Increased lateral dynamic stability margin at acute phase (P = 0.027, Cohen's d = 1.150)	1. Step length; 2. Step width; 3. GV; 4. Trunk roll angle	15
Repeated measures	Age: CONT: (20); CONC: (20)		Time point(s): 1. Acute (CONC- acute), average days = 5.3; 2. After return to play (CONC-RTP), average days = 26.4			
Canada	Male: 18		Task(s): 1. Walking in 5 possible directions (degrees)			
	n = 18 (9 concussions)					

Buckley et al [26]	Intercollegiate athletes	CISG [2]	Outcome(s): 1. GV (m/s); 2. Propulsive force percentage (N); 3. Breaking force percentage (N)	1. Decreased GV at day 1 (CI 95%, 1.1-1.2, P = 0.01, effect size = 1.14); 2. Increased propulsive force %: at day 1 (CI 95%, 0.24-0.64, P < 0.010, effect size = 0.85), and at day 10 (CI 95%, 0.23-0.69, P < 0.01, effect size = 0.85); 3. Increased breaking force % at day 1 (CI 95%, 0.17 to 0.07, P < 0.010, effect size = 0.540), and day10 (CI 95%, 0.03-0.29, P <0.010, effect size = 0.950)	None	11
Repeated measures	Mean age (SD; range): CONT: 20 (1.7; 19-22); CONC: 19 (1.0; 18-20)		Time point(s): day 1 and 10 post-concussion			
USA	Sex not reported		Task(s): 1. Self-selected walking			
	n = 47 (21 concussions)					

Chiu et al [27]	Athletes	AAN [7]	Outcome(s): 1. GV(m/s)	1. Decreased GV during Obstacle crossing (P = 0.015) and Walking + Q& A (P = 0.040)	None	10
No repeated measures	Mean age (SD; range): CONT: 21 (3.2; 18-25); CONC: 22 (3.6; 18-25)		Time point(s): 48 h post-concussion			
USA	Female: 18; Male: 28		Task(s): 1. Walking; 2. Walking + crossing obstacles; 3. Walking + Q& A			
	n = 46 (23 concussions)					
Howell et al [28]	High school students	CISG [2]	Outcome(s): 1. Average GV (m/s); 2. Step length (m); 3. Step width (m); 4. Peak A-P COMV (m/s); 5. Peak M-L COMV (m/s); 6. Total M-L COMD (m)	1. Decreased GV during Walk + MAS (F1,37 = 6.02, P = 0.019); 4. Decreased peak A-P COMV during Walk + MAS (F1,37 = 6.230, P = 0.017); 5. Increased peak M-L COMV (F1,37 = 5.320, P = 0.027); 6. Increased total M-L COMD during Walk + MAS (F1,37 = 6.750, P = 0.013)	2. Step length; 3. Step width	13

Repeated measures	Mean age (SD; range): CONT: 16 (1; 14-17); CONC: 15 (1; 14-18)		Time point(s): 72 h; 1, 2, 4, 8 wks post-concussion			
USA	Female: 4; Male: 36		Task(s): 1. Walk; 2. Walk + MAS			
	n = 40 (20 concussions)					
Kleffelgaard et al [29]	Adults	ACRM [7]	Outcome(s): 1. Normal walking speed (s); 2. Maximum walking speed (s); 3. 6 min Walk Test (m)	1. Increased normal walking speed in CONC + self-reported balance problems (P = 0.030); 2. Increased maximum walking speed in CONC + self-reported balance problems (P = 0.001); 3. Decreased 6 min walking test among in CONC + self-reported balance problems (P = 0.030)	None	14
No repeated measures	Mean age (SD; range): CONC: 40 (12.8; 27-53); CONT: Baseline data		Time point (s): Four years post-concussion			
Norway	Female: 10; Male: 19		Task(s): 1. CONC with and without self-reported balance problems			

	n = 29 (29 concussed)					
Catena et al [30]	Young adults	AAN [7]	Outcome(s): 1. Peak sagittal COMV; 2. Peak frontal COMV; 3. Sagittal COP angular ROM (degrees); 4. Frontal COP angular ROM (degrees); 5. COM-COPS; 6. Frontal COMD (degrees)	1. Decreased peak sagittal COMV at day 2 during Walk + SAS (P = 0.064); 3. Decreased sagittal COP angular ROM at day 2 during Walk + SAS (P = 0.041); 4. Increased frontal COP angular ROM at day 14 Walk + SAS (P = 0.006); 5. Decreased COM-COPS at day 2 (P = 0.041); 6. Increased frontal COMD at day 14 during Walk + SAS (P = 0.006)	2. Peak frontal COMV	11
Repeated measures	Mean age (SD; range): CONT: 21 (4.1; 17-25); CONC: 21 (3.1; 18-24)		Time point(s): 2, 6, 14, 28 d post-concussion			
USA	Female: 10; Male: 10		Condition Task(s): 1. Walking; 2. Walking + SAS			
	n = 20 (10 concussions)					
Catena et al	Collegiate athletes	AAN [7]	Outcome(s): 1. M-L	1. Decreased M-L	None	12

[31]	and non- athletes		COMV (m/s); 2. A–P COMV (m/s); 3. M–L COMD (m); 4. A–P COMD (m); 5. COM-COPS (m)	COMV at day 14 with short obstacle (P + 0.014), and day 28 with tall obstacle crossing (P + 0.013); 2. Decreased A–P COMV at day 2 during Walk + Q& A (P = 0.014); 3. Decreased M–L COMD at day 28 with short obstacle (P = 0.000), and tall obstacle crossing (P = 0.001); 4. Decreased A–P COMD at day 2 with Walk + Q&A (P = 0.014); 5. Decreased sagittal COM-COPS at day 2 during Walk + Q&A (P = 0.038)		
Repeated measures	Mean age (SD; range): CONT: 22 (3.1; 18-25); CONC: 22 (3.3; 19-25)		Time point(s): 2, 6, 14, 28 d post-concussion			
USA	Female: 28; Male: 32		Task(s): 1. Walk; 2. Walk + short obstacle crossing; 3. Walk + tall obstacle crossing; 4.			

			Walk + Q&A			
	n 5 60 (30 concussion)					
Catena et al [32]	Collegiate athletes	AAN [7]	Outcome(s): 1. Lead foot clearance (cm); 2. Trailing foot clearance (cm); 3. Obstacle contact (count)	1. Increased lead foot crossing height variability at day 28 (P = 0.012); 3. Increased obstacle contact (P = 0.003)	2. Trailing foot clearance	11
Repeated measures	Mean age (SD; range): CONT: 21 (2.3; 18-27); CONC: 21 (1.7; 18-24)		Time point(s): 2, 6, 14, 28 days post-concussion			
USA	Female: 16; Male: 18		Task(s): 1. Walk + obstacle crossing; 2. Walk + obstacle crossing + Q&A			
	n 5 34 (17 concussions)					

Parker et al [33]	Collegiate athletes and non-athletes	AAN [7]	Outcome(s): 1. M–L COMD (m); 2. Peak M–L COMV (m/ s); 3. Average GV (m/s); 4. Maximum A–P COM-COPS (m)	1. Increased M–L COMD during Walk + mental tasks (P = 0.002); 2. Increased peak M–L COMV during Walk + mental task (P = 0.001); 3. Decreased GV during Walk + mental task (P = 0.002); 4. Decreased maximum A–P COM-COPS at days 2, 5, 14 with Walk + mental task	None	12
Repeated measures	Mean age (range): CONT: 22 (19-27); CONC: 22 (18-27)		Time point(s): 2, 5, 14, 28 d post-concussion			
USA	Sex not reported		Task(s): 1. Walk; 2. Walk + mental task (spelling, subtraction, and reciting backwards)			
	n = 56 (28 concussions)					
Catena et al [34]	College students	AAN [7]	Outcome(s): 1. GV (m/s); 2. Stride length (m); 3. Average step width (m); 4. Stride time (s); 5. A–P COMD (m); 6. M–L COMD (m); 7. Peak M–L	1. Decreased GV (P = 0.007); 4. Increased stride time with Walk and Walk + Q&A (P = 0.020); 6. Increased M–L COMD with	2. Stride length; 3. Step width; 5. A–P COMD; 9. A–P COM-COPS; 10. M–L COM-COPS	10

			COMV (m/s); 8. Peak A-P COMV (m/s); 9. Maximum A-P COM-COPS (m); 10. Maximum M-L COM-COPS (m)	Walk and Walk + Q&A (P = 0.041); 7. Increased Peak M-L COMV with Walk and Walk + Q&A (P = 0.046); 8. Decreased peak A-P COMV (P = 0.007)		
No repeated measures	Mean age (SD; range): CONT: 22 (3; 19-25); CONC: 22 (4.5; 18-27)		Time point(s): 48 h post-concussion			
USA	Female: 12; Male: 16		Task(s): 1. Walk; 2. Walk + Q & A; 3. Walk + SAS			
	n 5 28 (14 concussions)					
Catena et al [35]	College students	AAN [7]	Outcome(s): 1. A-P COMD (m); 2. M-L COMD (m); 3. Peak A-P COMV (m/s); 4. Peak M-L COMV (m/s); 5. Maximum A-P COM-COPS (m); 6. Maximum M-L COM-COPS (m); 7. Instantaneous A-P velocity (m/s); 8.	2. Increased M-L COMD with Walk + Q&A (P = 0.045); 3. Decreased peak A-P velocity (P = 0.007); 4. Increased peak M-L COMV (P = 0.034); 5. Decreased maximum A-P COM-COPS during Walk + Q& A task (P =	1. A-P COMD; 6. Maximum M-L COM COPS (m/s); 8. Instantaneous M-L velocity; 10. Stride length	10

			Instantaneous M–L velocity (m/s); 9. GV (m/s); 10. Stride length (m); 11. Step width (m); 12. Stride time (s)	0.038); 7. Decreased Instantaneous A–P velocity with Walk + Q & A and obstacle crossing (P = 0.010); 9. Decreased GV (P = 0.003); 11. Increased step width with obstacle crossing (P = 0.040); 12. Increased stride time with Walk = Q & A and obstacle crossing (P = 0.006)		
No repeated measures	Mean age (SD; range): CONT: 22 (3.1; 19-25); CONC: 22 (4.5; 18-27)		Time point(s): A post-concussion time point			
USA	Female: 12; Male: 16		Task(s): 1. Walk; 2. Walk + obstacle crossing; 3. Walk + Q&A			
	n = 28 (14 concussions)					
Parker et al [36]	Collegiate athletes	AAN [7]	Outcome(s): 1. M–L COMD; 2. Peak M–L COMV (m/s); 3. Average GV (m/s); 4. Maximum A–P; COM-COPS (m)	1. Increased M–L COMD at days 5 and 28 with Walk + mental task (P < 0.050); 4. Increased maximum A–P COM-COPS (P =	2. Peak M–L COMV; 3. GV	15

				0.001)		
Repeated measures	Mean age (SD; range): CONT: 21 (3.4; 18-25); CONC: 22 (3.3; 18-25)		Time point(s): 2, 5, 14, 28 d post-concussion			
USA	Female: 28; Male: 30		Task(s): 1. Walk; 2. Walk + mental task; (spelling, subtraction, and reciting backwards)			
	n = 58 (29 concussions)					
Parker et al [37]	College athletes	AAN [7]	Outcome(s): 1. GV (m/s); 2. Stride length (m); 3. Stride time (s); 4. Step width (m); 5. M-L COMD (m); 6. Anterior COMD (m); 7. Maximum M-L COM-COPS; 8. Maximum A-P COM-COPS; 9. Peak maximum instantaneous linear anterior COMV (m/s); 10. Peak maximum instantaneous linear	1. Decreased GV at day 2 (P < 0.012); 2. Decreased stride length at days 2 (P < 0.016); 5. Increased M-L COMD at days 2, 5, 28 (P < 0.013); 8. Decreased maximum A-P COM-COPS at day 2 with Walk task (P < 0.005); 8. Decreased maximum A-P COM-COPS at	3. Stride time; 4. Step width; 6. Anterior COMD; 7. Maximum M-L COM-COPS; 9. Peak maximum instantaneous linear anterior COMV; 10. Peak maximum instantaneous linear M-L COMV	13

			M-L COMV (m/s)	Walk + mental tasks (P < 0.005)		
Repeated measures	Mean age (SD; range): CONT: 21 (1.8; 19-22); CONC: 21 (1.6; 19-22)		Time point(s): 2, 5, 14, 28 d post-concussion			
USA	Female: 12; Male: 18		Task(s): 1. Walk; 2. Walk + mental task (spelling, subtraction, and reciting backwards)			
	n = 30 (15 concussions)					
Parker et al [38]	Collegiate athletes	AAN [7]	Outcome(s): 1. GV (m/s); 2. Step width (m); 3. Stride length (m); 4. Stride time (s); 5. A-P COMD (m); 6. M-L COMD (m); 7. Maximum instantaneous linear A-P COMV; 8. Maximum instantaneous linear M-L COMV; 9. Maximum A-P COM-COPS (m); 10.	3. Decreased stride length (P = 0.042); 6. Increased M-L COMD with Walk + mental task, and decreased with Walk task (P = 0.021); 7. Decreased maximum instantaneous linear A-P COMV (P = 0.041)	1. GV; 2. Step width; 4. Stride time; 5. A-P COMD; 8. Maximum instantaneous linear M-L COMV; 9. Maximum A-P COM-COPS (m); 10. Maximum M-L COM-COPS	10

			Maximum M-L COM-COPS (m)		(m)	
No repeated measures	Mean age (SD; range): CONT: 20 (1.9; 18-22); CONC: 20 (1.7; 19-22)		Time point(s): Within 48 h post-concussion			
USA	Female: 12; Male: 8		Task(s): 1. Walk; 2. Walk + mental task (spelling, subtraction, and reciting backwards)			
	n = 20 (10 concussions)					
<p>A-P, anterior to posterior; COM, center of mass; COMD, center of mass displacement; COMV, center of mass velocity; CONC, concussed; CONT, control; COP, center of pressure; GV, gait velocity; LOC, loss of consciousness; m, meter; MAS, multiple auditory stimulus; M-L, medial to lateral; m/s, meter/second; Q & A, question and answers; RTP, return to practice; SAS, single auditory stimulus; SD, standard deviation.</p>						

Table 2-3: Systematic Review – Summary of Significant and Non-significant Gait Parameters by Quantity and Quality

Table 3: Summary of Significant and Non-significant Gait Parameters by Quantity and Quality						
Time Since Concussion	Gait Parameters	Studies With Repeated Measures		Studies Without Repeated Measures		Total Studies
		SIG	NOT	SIG	NOT	
10 d post-concussion	GV↓	5 (11-13)	4 (11-15)	4 (10)	1 (10)	14
	M-L COMV*	4 (12-16)	5 (11-15)	2 (10)	1 (10)	12
	A-P COMV↓	4 (11-16)	4 (11-13)	3 (10)	—	11
	M-L COMD↑	6 (11-16)	—	3 (10)	—	9
	COM-COPS*	4 (11-13)	—	1 (10)	2 (10)	7
	STW	—	3 (13-15)	1 (10)	2 (10)	6
	SRT	—	1 (13)	2 (10)	1 (10)	4
	STL	2 (12-13)	1 (13)	—	1 (10)	4

	SL	—	1 (15)	1 (10)	1 (10)	3
10 d post-concussion	M–L COMV*	5 (122-16)	3 (11-15)	—	1 (11)	9
	M–L COMD↑	8 (11-16)	—	—	—	8
	GV↓	3 (12-13)	2 (11-15)	1 (14)	—	6
	A–P COMV↓	1 (13)	2 (12-13)	—	—	3
	COM-COPS*	3 (12-15)	—	—	—	3
After RTA	GV↓	—	—	1 (14)	—	1
	M–L COMD↑	1 (13)	—	1 (11)	—	2
	M–L COMV↑	—	—	1 (11)	—	1

Cell values represent the number of studies (range of Downs and Black quality assessment tool scores).

* Inconsistently reported direction of effect.

↑, consistently reported as increased; ↓, consistently reported as decreased; A–P COMV, anterior to posterior center of mass velocity; COM-COPS, center of mass – center of pressure separation; GV, gait velocity; M–L COMD, medial to lateral center of mass displacement; M–L COMV, medial to lateral center of mass velocity; NOT, studies that do not report a statistically significant difference between concussed and no n-concussed study groups; RTA, return to activity; SIG, studies that report a statistically significant difference between concussed and non-concussed study groups; SL, stride length; SRT, stride time; STL, step length; STW, step width.

2.8 FIGURES

Figure 2-1: Systematic Review - Study Identification PRISMA Flowsheet

Figure 1: Study Identification PRISMA Flowsheet

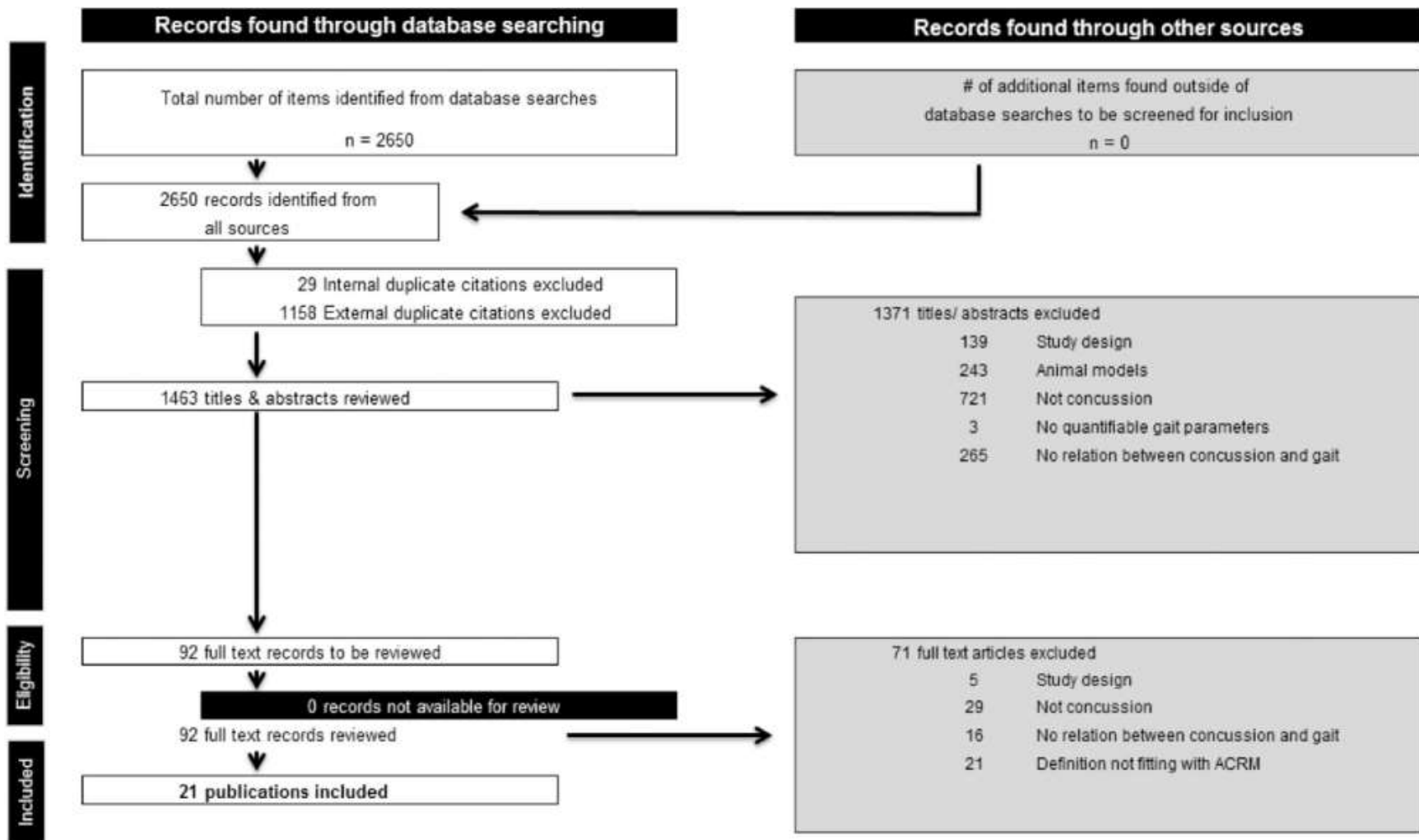

CHAPTER 3– RE-CONCEPTUALIZING POSTURAL CONTROL ASSESSMENT IN SPORT-RELATED CONCUSSION: TRANSITIONING FROM THE REFLEX/HIERARCHICAL MODEL TO THE SYSTEMS MODEL

A version of this chapter has been published. Manaseer TS GD, Mrazik M, Schneider K, Whittaker JL. Re-conceptualizing postural control assessment in sport-related concussion: Transitioning from the Reflex/Hierarchical Model to the Systems Model. Physiother Theory Pract. 2019;Aug(1):1-2.

ABSTRACT

While postural control impairment is common following sport-related concussion, few investigations have studied the physiological basis for this impairment. Both the Reflex/Hierarchical Model and the Systems Model are commonly used to characterize the physiological basis of postural control. The aim of this review was to discuss the physiological basis of postural control impairment resulting from sport-related concussion based on these models and suggest directions for future research. This review highlights that postural control impairment seen with sport-related concussion is a multifaceted construct that can result from deficits in numerous systems that underlie postural control as described by the Systems Model, rather than a unidimensional construct that stems from the central nervous systems' inability to integrate sensory input to control posture as per the Reflex/Hierarchical Model. Based on this discourse, we recommend a transition away from the Hierarchical/Reflex Model of postural control towards the Systems Model in the conceptualization of sport-related concussion. Future research on postural control following sport-related concussion should account for the multifaceted nature of the

resulting postural control impairment based on the Systems Model. Clinically, there is a need for a clinical postural control test that allows examination across the affected systems under single-task, dual-task, and sport-specific paradigms.

3.1 INTRODUCTION

Sport-related concussion (SRC) is a traumatic brain injury induced by either direct or indirect trauma to the head during the course of sporting activity.[1] SRC is a global health problem with an average annual incidence rate of 31.5/100,000 population.[2] SRCs are associated with a wide range of signs and symptoms that typically resolve within 10-14 days in adults and 30 days in children.[1] However, for up to 30% of individuals, symptoms may persist beyond this time period.[3] Common initial signs and symptoms include physical signs, cognitive or postural control impairments, behavioral changes, and sleep/wake disturbances.[1] Possible long-term consequences of SRC include cognitive impairments,[4] impaired postural control,[5] and increased risk of future musculoskeletal injury.[6] Among these consequences of SRC, postural control impairments are the focus of this article.

Impaired postural control is one of the most common signs of SRC with up to 30% of athletes with SRC demonstrating altered postural control.[1, 7] Historically, the clinical assessment of postural control in SRC has included the Balance Error Scoring System (BESS) and the Romberg test.[8, 9] These methods are practical and inexpensive to use in clinical and sport-related settings. That said, the BESS and Romberg tests have limited psychometric properties,[9] and are unable to identify lingering postural control deficits (e.g. impaired standing and gait) that can be detected using sophisticated measures of postural control (e.g. three dimensional movement analysis).[10, 11] Recently, therefore, there has been a call to develop new SRC postural control assessment methods.[1, 11] In order to appropriately develop new SRC postural control assessment methods, it is imperative to correctly characterize the physiological basis of the resulting postural control impairment.

According to Shumway-Cook and Woolcott,[12] both the Reflex/Hierarchical Model and the Systems Model are commonly used to characterize the physiological basis of postural control. In this review, we will discuss the physiological basis of postural control impairment following SRC based on these models and suggest directions for future research on postural control assessment following SRC.

3.2 SPORT-RELATED CONCUSSION AND THE REFLEX/HIERARCHICAL MODEL FOR POSTURAL CONTROL

According to the Reflex/Hierarchical Model, postural control is a simple skill that is controlled by one neurophysiological system.[13] The system consists of afferent pathways, the central nervous system, and efferent pathways.[7] Specifically, afferent pathways carry sensory cues from the visual, vestibular, and somatosensory mechanisms to the central nervous system. The central nervous system (i.e. cerebral cortex, cerebellum, basal ganglia, brainstem, and spinal cord) processes and hierarchically integrates the sensory cues. The spinal cord represents the lowest level of the hierarchy and is involved in the initial processing of somatosensory information, and the reflex and voluntary control of posture through the motor neurons.[12] Feedback based on the processed sensory cues travels along the efferent pathway to different muscles responsible for postural control and directs them to contract appropriately.[7]

According to this model, postural control impairment associated with SRC stems from the central nervous systems' inability to integrate sensory input, ignore changed environmental conditions, or apply the appropriate motor control strategies to maintain postural control.[14] Based on this, postural control recovery status following SRC can be assessed using tools that challenge one's

ability to accurately use and integrate sensory information from the visual, vestibular, and/or somatosensory mechanisms such as the BESS, the Romberg test, the Clinical Test of Sensory Organization and Balance, and the Sensory Organization Test.[7]

This reflex/hierarchical approach has been shown to be limited as it views postural control impairment stemming from a SRC as a unidimensional construct (i.e. only affects the sensory resources) without considering the motor and cognitive resources required for postural control that can also be disturbed with a SRC.[10] The utility of the reflex/hierarchical model for characterizing and/or examining postural control has generally decreased in the scientific literature due to its unidimensional nature.[15] Similarly, the utility of the reflex/hierarchical model for characterizing postural control does not align with the recommended multifaceted clinical assessment of SRC.[1] As a result, there has been a shift away from using approaches consistent with the Reflex/Hierarchical Model towards approaches consistent with the Systems Model when describing the physiological basis of postural control [15] and to guide the design of new clinical measures of postural control.[16] Although the Systems Model may be an alternative to the Reflex/Hierarchical Model for better characterizing the physiological basis of postural control impairment following SRC, there has not been a thorough characterization of postural control impairment resulting from SRC using this model.

3.3 SPORT-RELATED CONCUSSION AND THE SYSTEMS MODEL FOR POSTURAL CONTROL

According to the Systems Model, postural control is a complex skill that requires continuous interaction between the musculoskeletal and neural systems.[13] This interaction depends on the

task performed and is modified by environmental limitations.[13] The musculoskeletal component includes concepts related to the properties of muscles and joints, and the biomechanical relations between linked body parts.[12] The neural component includes: sensory processes that organize and integrate sensory cues from the visual, vestibular and somatosensory mechanisms; higher-levels processes (i.e. cognitive contributions) that map sensation into actions and control anticipatory and adaptive aspects of postural control; and motor processes that organize muscle action throughout the body.[12]

The Systems Model suggests that the main goals of postural control are postural stability and postural orientation (Horak, 2006).[13] Postural stability is defined as the ability to control center-of-mass within a controlled base of support (Horak, 2006).[13] Postural orientation, on the other hand, is defined as the ability to align the body segments in relation with gravity, visual surround, support surfaces, and internal references (i.e. models of the body and environment that are formulated by the parietal and temporal association cortical areas).[13, 17] As the body center-of-mass reflects the weighted average of each of the body segments, it is believed to be the key variable controlled by the postural control system.[12]

Building on the Systems Model, it has been suggested that six systems underlie postural control (Figure 1), each of which consists of a different neural circuit that is responsible for a specific aspect of postural control.[16] The underlying systems include movement strategies, control of dynamics, sensory strategies, cognitive contributions (i.e. dual-tasking), orientation in space, and biomechanical elements (Table 1).[16, 18] Although the underlying systems are independent of each other, the performance of a physical task requires continuous interaction among them.[16]

According to the Systems Model, altered postural control results from deficits in one or more of the underlying systems, and deficits in a single system may affect the ability to perform multiple tasks.[16] For example, vestibular system deficits may affect an injured athletes' ability to run in a straight line with their head turned or change direction, stand or walk on unstable surfaces, and/or track a flying ball.[16, 19] Several studies have supported this theory by showing the way in which deficits in one or more of the underlying systems result in altered postural control.[16] To understand how the Systems Model can be applied to SRC, it is important to understand how SRC is associated with deficits in multiple underlying systems responsible for postural control.

3.3.1 Movement strategies

The central nervous system uses both anticipatory and automatic postural responses to maintain the center-of-mass over the base-of-support and alignment between the center-of-mass and center-of-pressure.[20] To minimize the risk of losing postural stability, the central nervous system uses anticipatory postural responses by activating trunk and lower extremity muscles before initiating a movement.[20] Gait initiation is a task used frequently to examine the central nervous system's ability to use anticipatory postural responses.[14] To control gait initiation, the central nervous system should be able to regulate the spatial and temporal relationship between the location and motion of the center-of-mass.[21] Following a SRC, deficits in gait initiation have been noted.[22] While healthy adults are able to displace their center-of-pressure five to seven centimeters both in the posterior and lateral directions during gait initiation, Buckley, Oldham, Munkasy, and Evans [22] have reported a significant reduction in the posterior (pretest: 5.7 ± 1.6 centimeters; posttest: 2.6 ± 2.1 centimeters; $p < .001$) and lateral (pretest: 5.8 ± 2.1 centimeters; posttest: 3.8 ± 1.8 centimeters; $p < .001$) center-of-pressure displacement one day following SRC.

In contrast, the central nervous system uses automatic postural responses to restore the position of the center-of-mass after postural instability occurs.[20] Researchers and clinicians frequently use external perturbations to examine automatic postural responses.[12] External perturbations challenge postural stability by moving the center-of-mass outside the center-of-pressure, or moving the center-of-pressure from under the center-of-mass.[23] Typically, a healthy person sways, takes a step, or reaches to recover postural instability in response to an external perturbation.[12] Abnormal automatic postural responses include late (i.e. prolonged reaction time), weak, and hypermetric responses.[16] Following a SRC, deficits in automatic postural responses have been noted. For example, high school and collegiate athletes with a history of SRC demonstrated significant deteriorations in center-of-pressure control, hand kinematics (displacement and velocity), and reaction time when responding to external perturbations induced by the KINARM End Point Robot System, compared to athletes with no history of SRC.[23] Further, high school and collegiate athletes with acute (within 48 hours) SRC exhibited prolonged visuomotor reaction time while completing a clinical reaction time assessment (i.e. the Drop-stick test), compared to un-injured athletes.[24] Studies on movement strategies recovery following SRC have yielded mixed results. While deficits in anticipatory postural responses were detected up to 27 days following SRC,[22, 25] deficits in automatic postural responses have been detected up to 40 months following injury in others.[23]

3.3.2 Control of dynamics

In comparison to static postural stability, the control of dynamic postural stability (i.e. gait) is more challenging as it requires the control of a mobile center-of-mass, continually moving from the base-of-support.[13] Several laboratory studies have examined the association between SRC and

gait, and in turn identified gait deviations in athletes with SRC including: decreased gait velocity [26]; stride length [27]; anterior-posterior center-of-mass/center-of-pressure separation [28]; increased medial-lateral center-of-mass displacement [29]; and lateral dynamic stability margin and swing time during different walking tasks (i.e. walking and/or walking with changing direction).[30]

A recent systematic review concluded that SRC is associated with increased medial-lateral center-of-mass displacement and decreased gait velocity suggesting that athletes with a SRC may adopt a conservative approach to gait in order to better control the moving center-of-mass, and to minimize the risk of losing postural stability.[31] The authors, therefore suggested that a clinical test that aims at examining dynamic stability following SRC should include the assessment of gait velocity and medial-lateral center-of-mass displacement. Currently, the Tandem Gait Test is the most commonly used clinical test of dynamic stability following SRC [32]. This test involves walking in a forward direction as quickly and as accurately as possible along a 38 mm wide, three-meter line and back, with an alternate foot heel-to-toe gait. The total time it takes to complete the task, the ability to stay on the line and avoid separation of their heel and toe while maintaining posture are noted.[32] In a recent study, Howell, Osternig, and Chou [33] have examined the clinical utility of the Tandem Gait Test through examining time required to complete the test and medial-lateral center-of-mass displacement in a sample of concussed and uninjured controls. Concussed participants were tested at 72 hours, one week, two weeks, four weeks, and eight weeks following injury. Control participants were tested at the same testing schedule as injured participants. Concussed individuals walked slower than controls at the 72-hour time point only. Further, concussed individuals who walked slower tended to display greater medial-lateral center-

of-mass displacement across the two months testing period. Together, findings from the systematic review [31] and the study by Howell, Osternig, and Chou [33] further support the clinical utility of the Tandem Gait Test as a clinical measure of dynamic stability following SRC.

In terms of dynamic postural stability recovery, injured athletes exhibit an inconsistent pattern of recovery, in which various gait parameters show deficits at different time points following SRC. For instance, while deficits in the medial/lateral center-of-mass displacement were detected 28 days following SRC,[29] no deficits have been identified in the lateral dynamic stability margin beyond five days after a SRC.[30]

3.3.3 Sensory strategies

In order to maintain postural stability, sensory cues from visual, vestibular, and somatosensory mechanisms must be integrated in the brain (e.g. cerebral cortex, thalamus, reticular formation, cerebellum, and brain stem) to interpret complex sensory environments.[12, 13, 34] The visual mechanism provides information about the location of the body in space, the relation between body parts, and body motion in relation to the surrounding environment. Located in the inner ear, the vestibular labyrinth provides information related to the position and movement of the head. Finally, the somatosensory mechanism relies on mechanoreceptors located in the skin, muscles, joints, and ligaments to identify the position of the body in space.[12]

As the sensory environment changes, the brain re-weights its relative dependence on the different sensory mechanisms.[13] For example, while healthy individuals rely mostly on the somatosensory mechanism to maintain postural stability while standing on stable surfaces, they increase sensory weighting to the visual and vestibular mechanisms to maintain postural stability

on unstable surfaces.[35] Individuals' ability to re-weight their relative dependence on different sensory mechanisms can be altered by deficits in either the central nervous system (e.g. Parkinson's disease),[36] and/or the peripheral sensory mechanisms (e.g. peripheral vestibular loss).[13]

Following SRC, injured athletes frequently report postural instability, vertigo, and dizziness which suggest impaired integration of sensory cues from the vestibular mechanism with other sensory mechanisms in the cerebellum, thalamus, cerebral cortex, brainstem, and reticular formation.[34, 37] Further, injured athletes may report impaired eye movement (e.g. pursuit and saccades) which suggests dysfunction in the integration of sensory input in the midbrain, cerebral cortex, cerebellum, and pons.[34] Finally, SRC is believed to impair injured athletes' ability to re-weight their relative dependence on different sensory mechanisms under varying sensory conditions.[38] Typically, it is suggested that sensory strategies deficits, measured with conventional clinical postural control tests (e.g. BESS), recover within three to five days following SRC.[39] However, more precise measures of sensory strategies (i.e. a force plate) have identified persistent deficits in sensory strategies for more than a year following the initial injury.[40-42]

3.3.4 Cognitive contributions

According to the systems model, postural stability is not automatic and requires cognitive processing.[13] Therefore, the performance of concurrent postural stability and cognitive tasks may alter the performance of either or both tasks.[13] An understanding of postural stability assessment methods used in other clinical populations has fostered an interest in measuring the ability of athletes with SRC to perform a secondary cognitive task while controlling stability (i.e.

dual-tasking).[43, 44] The most common assessments of dual-task performance after SRC involve walking while completing a cognitive task and/or undertaking postural stability tasks simultaneously with a cognitive activity.[44] Cognitive tasks that are frequently used include a simple question and answer format or basic mental status questions.[27-29, 45-49] Examples include: an auditory version of the Stroop task [46, 50-56]; a Stroop color and word test [57]; or spelling, counting or reciting backwards.[27, 28, 48, 49, 58] Following a SRC, deficits in dual-task performance have been reported. A previous systematic review of the role of dual-task assessment in the management of SRC, Register-Mihalik, Littleton, and Guskiewicz [44] concluded that response times and postural stability deficits (i.e. sway and errors) are greater leading to less efficient gait (i.e. more sway and more conservative gait pattern) strategies in injured athletes compared with uninjured controls both immediately, and for some time following SRC, specifically under dual-task assessments. Further, dual-task assessments may be better able to identify longer lasting impairments in postural stability following SRC as compared to single-task performance (i.e. controlling postural stability without a secondary cognitive task).

3.3.5 Orientation in space

Healthy individuals are able to automatically adapt to the bodies orientation in space based on the context and task performed.[13] For example, as a supporting surface tilts, an individual without a postural dysfunction re-orientes the body to gravity or the visual surround.[17] Perception of verticality and control of body orientation require that the central nervous system integrates sensory cues from the visual, vestibular, and somatosensory mechanism, and creates internal references of verticality.[17] Consequently, injuries or pathologies that impact the central nervous

system's ability to integrate sensory cues, and/or alter internal references of verticality can impact postural orientation.[17]

The Neurocom Sensory Organization Test (SOT) is frequently used to assess postural orientation after SRC.[59] A detailed description of the SOT protocol has been provided elsewhere.[59] Briefly, the SOT is designed to systematically disrupt the sensory selection process by altering the orientation information available to the somatosensory and/or visual mechanisms while a force plate measures vertical ground reaction forces generated by the body's center-of-pressure during involuntary sway. Traditionally, postural orientation has been considered linear (i.e. based on stimulus-response paradigms). Therefore, linear measures of center-of-pressure variability (e.g. position, displacement path length, velocity, standard deviation, and acceleration) have been used to quantify postural sway.[60, 61] Recent studies, however, addressed the notion that postural orientation is nonlinear (i.e. is achieved through the interaction between different sensory mechanisms) and, therefore, it is best examined via nonlinear measures of center-of-pressure variability (e.g. approximate entropy, sample entropy, Shannon entropy, and Renyi entropy).[10, 60, 61] Approximate entropy and sample entropy, which characterize the regularity of center-of-pressure over time-series data, are commonly used nonlinear measures in post-SRC postural orientation assessment.[10] That being said, Montesinos, Castaldo, and Pecchia [62] suggest future studies should favor sample entropy over approximate entropy given its higher consistency.

Several studies [5, 42, 59, 63-67] have examined postural orientation in athletes with a diagnosis of SRC using the SOT. While studies that utilized linear measures of center-of-pressure variability [59, 63, 65-67] could identify deficits in postural orientation (e.g. increased anterior-posterior center-of-gravity displacement) up to five days following SRC, studies that utilized nonlinear

measures of center-of-pressure variability [5, 42, 64] could identify deficits in postural orientation (e.g. altered medial-lateral and anterior-posterior center-of-pressure regularity) for more than one year following SRC. The identified postural orientation deficits have been attributed mainly to the central nervous system's inability to integrate sensory cues from visual, vestibular, and somatosensory mechanisms.[68]

3.3.6 Biomechanical elements

The ability to control posture depends on multiple biomechanical elements including the quality and size of the base-of-support, lower extremity range of motion, center-of-mass alignment, as well as lower extremity and trunk muscle strength.[13] In addition to these elements, functional limits of stability depend on the representation of those limits in the central nervous system.[13] Injuries to the biomechanical elements may result in postural control impairments. Following SRC, injured athletes frequently report headache, dizziness, nausea, and neck pain.[69] These symptoms can be attributed to a concomitant cervical spine injury.[70] A recent study involving 69 adolescent (13–17 years of age) hockey players demonstrated significant worsening in cervical spine measures acutely following SRC as compared to baseline.[71] The concurrent involvement of the cervical spine may lead to an impairment of the vestibulocollic and cervical-ocular reflexes and/or a limited ability to align or to move the head over the trunk,[72] which may cause or exacerbate postural control impairments associated with SRC.[73] Therefore, a multifaceted assessment of SRC, including the assessment of the cervical spine is recommended.[74] In addition to the cervical spine, we believe that the assessment of other biomechanical elements are relevant to postural control examination following SRC. In a given scenario, athletes may sustain a concomitant lower extremity injury at the time they suffer a SRC, or have a pre-existing

mechanical impairment. Assessing biomechanical elements at baseline, and updating these measurements following the lower limb injury would make it possible to identify whether the resulting postural control deficits are attributed to the previous lower extremity injury or the more recent SRC. Finally, the assessment of biomechanical elements can inform rehabilitation programs that aim to improve postural control,[75] and prevent subsequent injuries.[76]

3.4 SPORT-RELATED CONCUSSION AND THE SYSTEMS MODEL FOR POSTURAL CONTROL: CRITIQUE AND SUMMARY

Based on the aforementioned studies, it can be hypothesized that impaired postural control associated with SRC is a multifaceted construct involving deficits in multiple underlying systems. This includes deficits in movement strategies, control of dynamics, sensory strategies, cognitive contributions (i.e. dual-tasking), and orientation in space. At present, it is challenging to understand the basis for recovery of postural control following SRC. This is mainly due to a paucity of studies examining recovery across different systems that underlie postural control and that are affected by SRC. Although it has been suggested that recovery of postural control occurs within three to 10 days following SRC, [7, 68] based on investigations mentioned above, recovery may be extended beyond this period of time due to the number of underlying postural control systems that can be impaired following SRC and the complexity of their interactions.

It is important to acknowledge the methodological limitations of studies investigating the association between SRC and deficits in multiple systems that underlie postural control. The highest level of evidence demonstrated by most studies discussed here as per to the Oxford Centre of Evidence-Based Medicine model is level 4, corresponding to cross-sectional, case-control, or

poor-quality prognostic cohort studies.[77] To address these limitations, a recent systematic review recommended that future research should focus on high-quality prospective studies with sufficient sample sizes spanning the time between baseline assessments of SRC and return-to-play and beyond.[31]

Recommendations for addressing multiple systems that are required for postural control were also addressed in the fifth international consensus statement on concussion in sport.[1] Specifically, this consensus statement highlighted the importance of a multifaceted assessment following SRC, including the evaluation of dynamic and static stability, and listed clinical reaction time assessment as an additional domain that may add to the clinical utility of the Sports Concussion Assessment Tool. Further, the consensus statement highlighted that athletes with SRC frequently experience persistent attention deficits. By merging the findings from studies that have examined postural control following SRC and recommendations from the fifth international consensus statement on concussion in sport, we conclude that SRC can be associated with deficits in multiple systems that underlie postural control including movement strategies (reaction time), dynamic control (gait), sensory strategies (sensory integration), and cognitive contributions (dual-task). Based on this, a transition away from the Hierarchical/Reflex Model of postural control in the conceptualization of SRC, and towards the Systems Model is recommended. While the focus of the current review is postural control impairment following SRC, the content is relevant to other populations with altered postural control.

3.5 IMPLICATIONS FOR FUTURE RESEARCH AND CLINICAL ASSESSMENT OF POSTURAL CONTROL IMPAIRMENTS FOLLOWING SPORT-RELATED CONCUSSION

Impaired postural control caused by SRC is a multifaceted affecting multiple systems rather than a unidimensional affecting only sensory system construct. This is a critical concept in establishing the determinants (i.e. incidence and severity) of postural deficits following SRC and, ultimately, developing preventive measures to improve return-to-play outcomes facilitated by rehabilitation as well as preventing reinjury.[78-80] It is recommended that future studies of postural control in SRC adopt a working definition that accounts for the multifaceted nature of the resulting postural control impairments based on the Systems Model.

Clinically, there is a need for a comprehensive clinical postural control assessment battery to detect postural control impairment in athletes with SRC. Traditionally, assessments of postural control following SRC have included the Clinical Test of Sensory Organization and Balance, the Sensory Organization Test, the BESS, and the Romberg test.[9] As has been outlined in this paper, these tests are limited in their ability to comprehensively assess postural control systems affected by SRC.[18, 81] Theoretically, the comprehensive battery should challenge an injured athlete's movement strategies (i.e. reaction time), control of dynamics (i.e. gait), and sensory strategies (i.e. sensory integration) with single- and dual-task paradigms. Examples include the Drop-stick test, the Tandem Gait Test, and the Balance Error Scoring System, respectively, performed with and without concurrent cognitive tasks.[33, 82, 83] As the interaction between these systems is task-dependent,[13] the battery should also challenge the injured athlete's postural control under complex tasks required for sports participation (i.e. sport-specific tasks) prior to return-to-play (Figure 2).

Although testing sport-specific tasks is recommended as part of the graduated return-to-sport strategy following SRC,[1] there is a lack of standardization of postural control components that

should be included in the sport-specific testing. Based on findings of the current review, we suggest that an appropriate sport-specific postural control test could involve repeated head turns to stimulate the vestibular mechanisms,[34] running in a limited space to challenge medial to lateral center-of-mass displacement,[31] and a concurrent cognitive task (e.g., Go/No-Go task).[84] By identifying the affected system(s) underlying altered postural control, clinicians can direct specific interventions for different types of postural deficits following SRC.[13] Further developmental and evaluation research is needed to establish an evidenced-based battery of assessments including the use of prospective methods to track athletes' recovery from SRC.

3.6 CONCLUSION

Impaired postural control is a common sign of SRC. Traditionally, the Reflex/Hierarchical model has been used to characterize the physiological basis of the resulting postural control impairment. This model, however, is limited as it views the resulting postural control impairment as a unidimensional construct (i.e. only affecting sensory resources) without considering the motor and cognitive resources required for postural control that are often disturbed following SRC. Alternatively, the physiological basis of postural control impairment associated with SRC can be characterized based on the Systems Model. This model posits that the resulting postural control impairment is caused by deficits in multiple systems that underlie postural control, including movement strategies, control of dynamics, sensory strategies, and cognitive contributions. Future research on postural control following SRC should account for the multifaceted nature of the resulting postural control impairment based on the Systems Model. Clinically, there is a need for a clinical postural test that allows examination across the affected systems under single-task, dual-task, and sport-specific paradigms.

3.7 REFERENCES

1. McCrory P, Meeuwisse W, Dvorak J, Aubry M, Bailes J, Broglio S, et al. Consensus statement on concussion in sport-the 5(th) International Conference on Concussion in Sport held in Berlin, October 2016. *Br J Sports Med.* 2017;51(11):838-47.
2. Selassie AW, Wilson DA, Pickelsimer EE, Voronca DC, Williams NR, Edwards JC. Incidence of sport-related traumatic brain injury and risk factors of severity: a population-based epidemiologic study. *Ann Epidemiol.* 2013;23(12):750-6.
3. Zemek R, Barrowman N, Freedman SB, Gravel J, Gagnon I, McGahern C, et al. Clinical risk score for persistent postconcussion symptoms among children with acute concussion in the ED. *JAMA.* 2016;315(10):1014-25.
4. Hume PA, Theadom A, Lewis GN, Quarrie KL, Brown SR, Hill R, et al. A comparison of cognitive function in former Rugby Union players compared with former non-contact-sport players and the impact of concussion history. *Sports Med.* 2017;47(6):1209-20.
5. De Beaumont L, Mongeon D, Tremblay S, Messier J, Prince F, Leclerc S, et al. Persistent motor system abnormalities in formerly concussed athletes. *J Athl Train.* 2011;46(3):234-40.
6. Pietrosimone B, Golightly YM, Mihalik JP, Guskiewicz KM. Concussion frequency associates with musculoskeletal injury in retired NFL players. *Med Sci Sports Exerc.* 2015;47(11):2366-72.
7. Guskiewicz KM. Balance assessment in the management of sport-related concussion. *Clin Sports Med.* 2011;30(1):89-102, ix.

8. Murray NG, Reed-Jones RJ, Szekely BJ, Powell DW. Clinical assessments of balance in adults with concussion: an update. *Semin Speech Lang*. 2019;40(01):048-56.
9. Murray N, Salvatore A, Powell D, Reed-Jones R. Reliability and validity evidence of multiple balance assessments in athletes with a concussion. *J Athl Train*. 2014;49(4):540-9.
10. Buckley TA, Oldham JR, Caccese JB. Postural control deficits identify lingering post-concussion neurological deficits. *Sport Sci Health*. 2016;5(1):61-9.
11. Johnston W, Coughlan GF, Caulfield B. Challenging concussed athletes: the future of balance assessment in concussion. *QJM*. 2016;110(12):779-83.
12. Shumway-Cook A, Woollacott MH. *Motor control: translating research into clinical practice*. 3rd ed. Philadelphia: Lippincott Williams & Wilkins; 2007.
13. Horak FB. Postural orientation and equilibrium: what do we need to know about neural control of balance to prevent falls? *Age Ageing*. 2006;35 Suppl 2(SUPPL.2):ii7-ii11.
14. Slobounov SM, Sebastianelli WJ. *Concussions in athletics: from brain to behavior*. New York: Springer Science & Business Media; 2014.
15. Gillen G. *Stroke rehabilitation: a function-based approach*. 4th ed. St. Louis, MO: Elsevier Health Sciences; 2016.
16. Fay B, Horak DMW, James Frank. The Balance Evaluation Systems Test (BESTest) to Differentiate Balance Deficits. *Phys Ther*. 2003;14(3):278-82.

- 17.Horak FB. Postural Control. Encyclopedia of Neuroscience. Berlin, Heidelberg: Springer Berlin Heidelberg; 2009.
- 18.Sibley KM, Beauchamp MK, Van Ooteghem K, Straus SE, Jaglal SB. Using the systems framework for postural control to analyze the components of balance evaluated in standardized balance measures: a scoping review. Arch Phys Med Rehabil. 2015;96(1):122-32 e29.
- 19.Broglio SP, Collins MW, Williams RM, Mucha A, Kontos AP. Current and emerging rehabilitation for concussion: a review of the evidence. Clin Sports Med. 2015;34(2):213-31.
- 20.Santos MJ, Kanekar N, Aruin AS. The role of anticipatory postural adjustments in compensatory control of posture: 2. Biomechanical analysis. J Electromyogr Kinesiol. 2010;20(3):398-405.
- 21.Mille M-L, Johnson ME, Martinez KM, Rogers MW. Age-dependent differences in lateral balance recovery through protective stepping. Clin Biomech (Bristol, Avon). 2005;20(6):607-16.
- 22.Buckley TA, Oldham JR, Munkasy BA, Evans KM. Decreased anticipatory postural adjustments during gait initiation acutely postconcussion. Arch Phys Med Rehabil. 2017;98(10):1962-8.
- 23.Dierijck JK. Multiple concussions and dual task paradigms: reactive postural perturbation management [dissertation]. University of British Columbia; 2017.
- 24.Eckner JT, Kutcher JS, Broglio SP, Richardson JK. Effect of sport-related concussion on clinically measured simple reaction time. Br J Sports Med. 2014;48(2):112-8.

25. Buckley TA, Munkasy BA, Tapia-Lovler TG, Wikstrom EA. Altered gait termination strategies following a concussion. *Gait Posture*. 2013;38(3):549-51.
26. Galetta KM, Morganroth J, Moehringer N, Mueller B, Hasanaj L, Webb N, et al. Adding vision to concussion testing: a prospective study of sideline testing in youth and collegiate athletes. *J Neuroophthalmol*. 2015;35(3):235-41.
27. Parker TM, Osternig LR, Lee HJ, Donkelaar P, Chou LS. The effect of divided attention on gait stability following concussion. *Clin Biomech (Bristol, Avon)*. 2005;20(4):389-95.
28. Parker TM, Osternig LR, P VAND, Chou LS. Gait stability following concussion. *Med Sci Sports Exerc*. 2006;38(6):1032-40.
29. Catena RD, van Donkelaar P, Chou LS. Different gait tasks distinguish immediate vs. long-term effects of concussion on balance control. *J Neuroeng Rehabil*. 2009;6:25.
30. Powers KC, Kalmar JM, Cinelli ME. Dynamic stability and steering control following a sport-induced concussion. *Gait Posture*. 2014;39(2):728-32.
31. Manaseer TS, Gross DP, Dennett L, Schneider K, Whittaker JL. Gait deviations associated with concussion: A Systematic Review [published online ahead of print, 2017 Nov 21]. *Clin J Sport Med*. 2017;10.1097/JSM.0000000000000537. doi:10.1097/JSM.0000000000000537.
32. Echemendia RJ, Meeuwisse W, McCrory P, Davis GA, Putukian M, Leddy J, et al. The Sport Concussion Assessment Tool 5th Edition (SCAT5): background and rationale. *Br J Sports Med*. 2017;51(11):848-50.

33. Howell DR, Osternig LR, Chou LS. Single-task and dual-task tandem gait test performance after concussion. *J Sci Med Sport*. 2017;20(7):622-6.
34. Kontos AP, Deitrick JM, Collins MW, Mucha A. Review of vestibular and oculomotor screening and concussion rehabilitation. *J Athl Train*. 2017;52(3):256-61.
35. Peterka RJ. Sensorimotor integration in human postural control. *J Neurophysiol*. 2002;88(3):1097-118.
36. Park J-H, Kang Y-J, Horak FB. What is wrong with balance in Parkinson's disease? *Mov Disord*. 2015;8(3):109.
37. Mallinson AI, Longridge NS. Dizziness from whiplash and head injury: differences between whiplash and head injury. *Otol Neurotol*. 1998;19(6):814-8.
38. Gera G, Chesnutt J, Mancini M, Horak FB, King LA. Inertial sensor-based assessment of central sensory integration for balance after mild traumatic brain injury. *Mil Med*. 2018;183(suppl_1):327-32.
39. Bell DR, Guskiewicz KM, Clark MA, Padua DA. Systematic review of the Balance Error Scoring System. *Sports Health*. 2011;3(3):287-95.
40. Powers KC, Kalmar JM, Cinelli ME. Recovery of static stability following a concussion. *Gait Posture*. 2014;39(1):611-4.
41. Schmidt JD, Terry DP, Ko J, Newell KM, Miller LS. Balance regularity among former high school football players with or without a history of concussion. *J Athl Train*. 2018;53(2):109-14.

- 42.Sosnoff JJ, Broglio SP, Shin S, Ferrara MS. Previous mild traumatic brain injury and postural-control dynamics. *J Athl Train.* 2011;46(1):85-91.
- 43.Lee H, Sullivan SJ, Schneiders AG. The use of the dual-task paradigm in detecting gait performance deficits following a sports-related concussion: a systematic review and meta-analysis. *J Sci Med Sport.* 2013;16(1):2-7.
- 44.Register-Mihalik JK, Littleton AC, Guskiewicz KM. Are divided attention tasks useful in the assessment and management of sport-related concussion? *Neuropsychol Rev.* 2013;23(4):300-13.
- 45.Catena RD, van Donkelaar P, Halterman CI, Chou LS. Spatial orientation of attention and obstacle avoidance following concussion. *Exp Brain Res.* 2009;194(1):67-77.
- 46.Catena RD, van Donkelaar P, Chou LS. Cognitive task effects on gait stability following concussion. *Exp Brain Res.* 2007;176(1):23-31.
- 47.Catena RD, van Donkelaar P, Chou L-S. Altered balance control following concussion is better detected with an attention test during gait. *Gait Posture.* 2007;25(3):406-11.
- 48.Parker TM, Osternig LR, van Donkelaar P, Chou LS. Recovery of cognitive and dynamic motor function following concussion. *Br J Sports Med.* 2007;41(12):868-73; discussion 73.
- 49.Parker TM, Osternig LR, van Donkelaar P, Chou LS. Balance control during gait in athletes and non-athletes following concussion. *Med Eng Phys.* 2008;30(8):959-67.
- 50.Catena RD, van Donkelaar P, Chou LS. The effects of attention capacity on dynamic balance control following concussion. *J Neuroeng Rehabil.* 2011;8:8.

51. Howell DR, Osternig LR, Christie AD, Chou L-S. Return to physical activity timing and dual-task gait stability are associated 2 months following concussion. *J Head Trauma Rehabil.* 2015.
52. Howell DR, Osternig LR, Chou LS. Return to activity after concussion affects dual-task gait balance control recovery. *Med Sci Sports Exerc.* 2015;47(4):673-80.
53. Howell D, Osternig L, Chou LS. Monitoring recovery of gait balance control following concussion using an accelerometer. *J Biomech.* 2015;48(12):3364-8.
54. Howell DR, Osternig LR, Koester MC, Chou LS. The effect of cognitive task complexity on gait stability in adolescents following concussion. *Exp Brain Res.* 2014;232(6):1773-82.
55. Howell DR, Osternig LR, Chou LS. Dual-task effect on gait balance control in adolescents with concussion. *Arch Phys Med Rehabil.* 2013;94(8):1513-20.
56. Howell DR, Osternig LR, Chou LS. Adolescents demonstrate greater gait balance control deficits after concussion than young adults. *Am J Sports Med.* 2015;43(3):625-32.
57. Rochefort C, Walters-Stewart C, Aglipay M, Barrowman N, Zemek R, Sveistrup H. Balance markers in adolescents at 1 month postconcussion. *Orthop J Sports Med.* 2017;5(3):2325967117695507.
58. Howell DR, Beasley M, Vopat L, Meehan WP, 3rd. The effect of prior concussion history on dual-task gait following a concussion. *J Neurotrauma.* 2017;34(4):838-44.
59. Guskiewicz KM, Ross SE, Marshall SW. Postural stability and neuropsychological deficits after concussion in collegiate athletes. *J Athl Train.* 2001;36(3):263-73.

60. Cavanaugh JT, Guskiewicz KM, Stergiou N. A nonlinear dynamic approach for evaluating postural control: new directions for the management of sport-related cerebral concussion. *Sports Med.* 2005;35(11):935-50.
61. Kirchner M, Schubert P, Schmidbleicher D, Haas C. Evaluation of the temporal structure of postural sway fluctuations based on a comprehensive set of analysis tools. *Physica A: Statistical Mechanics and its Applications.* 2012;391(20):4692-703.
62. Montesinos L, Castaldo R, Pecchia L. On the use of approximate entropy and sample entropy with centre of pressure time-series. *J Neuroeng Rehabil.* 2018;15(1):116.
63. Broglio SP, Macciocchi SN, Ferrara MS. Sensitivity of the concussion assessment battery. *Neurosurgery.* 2007;60(6):1050-7; discussion 7-8.
64. Cavanaugh JT, Guskiewicz KM, Giuliani C, Marshall S, Mercer VS, Stergiou N. Recovery of postural control after cerebral concussion: new insights using approximate entropy. *J Athl Train.* 2006;41(3):305.
65. Guskiewicz KM, Riemann BL, Perrin DH, Nashner LM. Alternative approaches to the assessment of mild head injury in athletes. *Med Sci Sports Exerc.* 1997;29(7 Suppl):S213-21.
66. Peterson CL, Ferrara MS, Mrazik M, Piland S, Elliott R. Evaluation of neuropsychological domain scores and postural stability following cerebral concussion in sports. *Clin J Sport Med.* 2003;13(4):230-7.

- 67.Riemann BL, Guskiewicz KM. Effects of mild head injury on postural stability as measured through clinical balance testing. *J Athl Train.* 2000;35(1):19-25.
- 68.Ruhe A, Fejer R, Gänsölen A, Klein W. Assessing postural stability in the concussed athlete: what to do, what to expect, and when. *Sports health.* 2014;6(5):427-33.
- 69.Marshall CM. Sports-related concussion: A narrative review of the literature. *J Can Chiropr Assoc.* 2012;56(4):299-310.
- 70.Morin M, Langevin P, Fait P. Cervical spine involvement in mild traumatic brain injury: a Review. *J Sports Med.* 2016;2016:1590161.
- 71.Schneider KJ, Palacios-Derflinger L, Meeuwisse WH, Emery CA. Changes in measures of cervical, vestibular, dynamic balance and tasks of divided attention following sport-related concussions in elite youth ice hockey players. *Br J Sports Med.* 2017;51(11):A47-A8.
- 72.Allison L. Imbalance following traumatic brain injury in adults: causes and characteristics. *J Neurol Phys Ther.* 1999;23(1):13-8.
- 73.Register-Mihalik JK, Mihalik JP, Guskiewicz KM. Balance deficits after sports-related concussion in individuals reporting posttraumatic headache. *Neurosurgery.* 2008;63(1):76-80; discussion -2.
- 74.Cheever K, Kawata K, Tierney R, Galgon A. Cervical injury assessments for concussion evaluation: a review. *J Athl Train.* 2016;51(12):1037-44.

75. Brachman A, Kamieniarz A, Michalska J, Pawłowski M, Słomka KJ, Juras G. Balance training programs in athletes—a systematic review. *J Hum Kinet.* 2017;58(1):45-64.
76. Aaltonen S, Karjalainen H, Heinonen A, Parkkari J, Kujala UM. Prevention of sports injuries: systematic review of randomized controlled trials. *Arch Intern Med.* 2007;167(15):1585-92.
77. Howick J, Phillips B, Ball C, et al. Oxford centre for evidence-based medicine: Levels of evidence 2009. Oxford Centre for Evidence-Based Medicine; 2009 [Accessed January 3, 2016]. Available at: <http://www.cebm.net/oxford-centre-evidence-based-medicine-levels-evidence-march-2009/>.
78. Cross M, Kemp S, Smith A, Trewartha G, Stokes K. Professional Rugby Union players have a 60% greater risk of time loss injury after concussion: a 2-season prospective study of clinical outcomes. *Br J Sports Med.* 2016;50(15):926-31.
79. Lynall RC, Mauntel TC, Padua DA, Mihalik JP. Acute lower extremity injury rates increase after concussion in college athletes. *Med Sci Sports Exerc.* 2015;47(12):2487-92.
80. van Mechelen W, Hlobil H, Kemper HC. Incidence, severity, aetiology and prevention of sports injuries. A review of concepts. *Sports Med.* 1992;14(2):82-99.
81. McMichael KA, Vander Bilt J, Lavery L, Rodriguez E, Ganguli M. Simple balance and mobility tests can assess falls risk when cognition is impaired. *Geriatr Nurs.* 2008;29(5):311-23.
82. Eckner JT, Whitacre RD, Kirsch NL, Richardson JK. Evaluating a clinical measure of reaction time: an observational study. *Percept Mot Skills.* 2009;108(3):717-20.

83. Ross LM, Register-Mihalik JK, Mihalik JP, McCulloch KL, Prentice WE, Shields EW, et al. Effects of a single-task versus a dual-task paradigm on cognition and balance in healthy subjects. *J Sport Rehabil.* 2011;20(3):296-310.

84. Howell DR, Meehan III WP, Barber Foss KD, Reches A, Weiss M, Myer GD. Reduced dual-task gait speed is associated with visual Go/No-Go brain network activation in children and adolescents with concussion. *Brain Inj.* 2018;32(9):1129-34.

3.8 TABLES

Table 3-1: Underlying Postural Control Systems Operational Definitions

Table 1: Underlying Postural Control Systems Operational Definitions

Underlying System	Operational Definition
Movement strategies:	<ul style="list-style-type: none"> • Automatic postural control: the ability to recover stability following an external perturbation to bring the center of mass within the base of support through corrective movements (e.g., ankle, hip, stepping strategies). This includes late, weak, and hypermetric responses. • Anticipatory postural control: the ability to shift the center of mass prior to a discrete voluntary movement (e.g., stepping, arm raise, head turn)
Control of dynamics	<ul style="list-style-type: none"> • The ability to keep the center of mass within its base of support while walking (e.g., during gait, postural transitions)
Sensory strategies	<ul style="list-style-type: none"> • The ability to reweight sensory information (vision, vestibular, somatosensory) when input is altered

<p>Cognitive contributions (i.e., dual-tasking)</p>	<ul style="list-style-type: none"> • The ability to maintain stability while responding to commands during the task or attend to additional tasks
<p>Orientation in space</p>	<ul style="list-style-type: none"> • The ability to orient appropriately with respect to gravity (e.g., evaluation of lean), the support surface, visual surround and internal references (i.e., models of the body and environment that are formulated by the parietal and temporal association cortical areas)
<p>Biomechanical elements:</p>	<ul style="list-style-type: none"> • Functional limits of stability: the ability to move the center of mass as far as possible in the anterior-posterior or medio-lateral directions within the base of support • Underlying motor elements: this includes strength and coordination • Static stability: the ability to maintain the position of the center of mass in unsupported stance when the base of support does not change (may include wide stance, narrow, one-legged stance, tandem, or any standing condition)

Note: Adapted from Sibley et al. 2015 and Horak 2006.

3.9 FIGURES

Figure 3-1: Systems that Underlie Postural Control

Figure 1: Systems that Underlie Postural Control. Arrows represent the continuous interaction between different systems (adapted from Horak et al, 2009; Sibley et al, 2015)

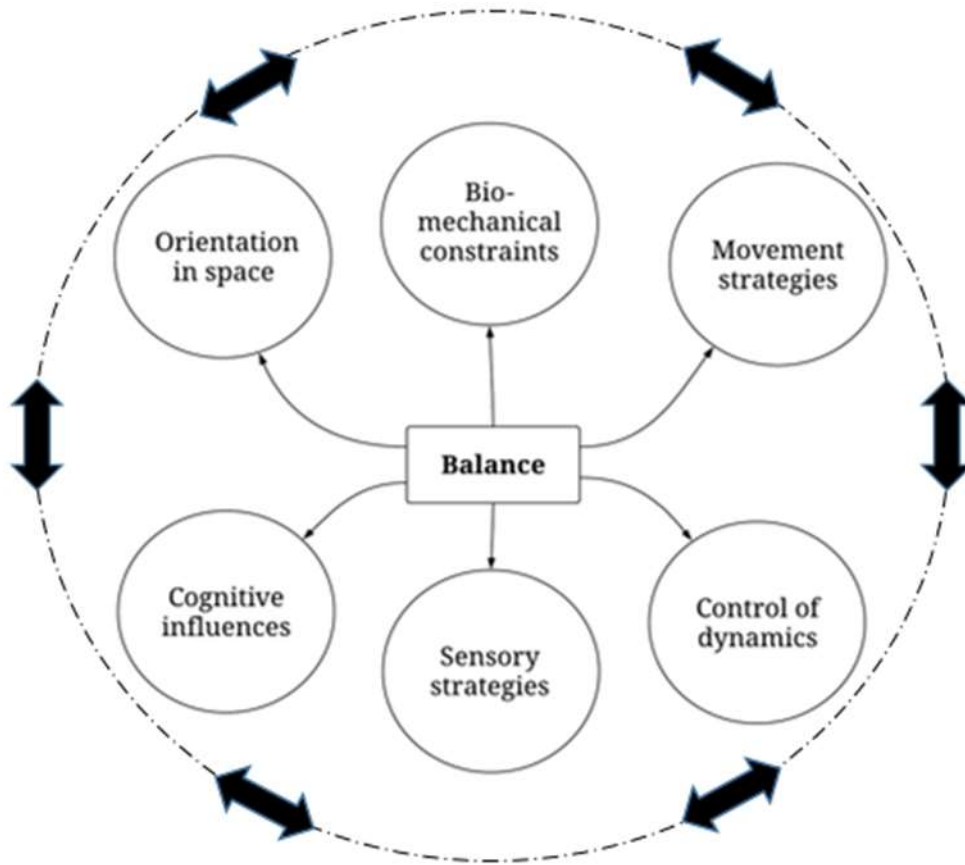
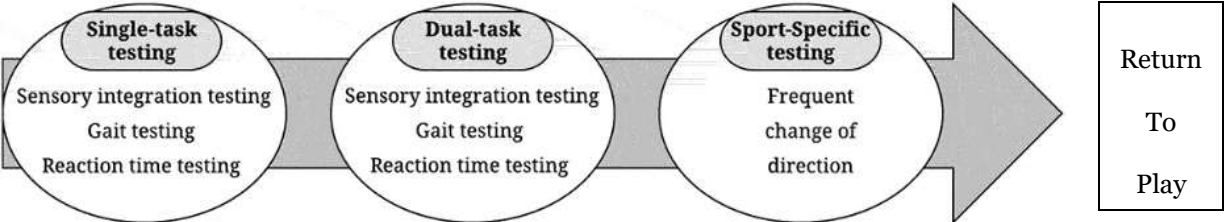

Figure 3-2: A New Model of Postural Control Assessment in Sport-Related Concussion

Figure 2: A New Model of Postural Control Assessment in Sport-Related Concussion



CHAPTER 4– THE RELIABILITY OF CLINICAL POSTURAL CONTROL TESTS UNDER SINGLE-TASK AND DUAL-TASK TESTING PARADIGMS

A version of this chapter has been provisionally accepted for publication in The International Journal of Sports Physical Therapy.

ABSTRACT

Background: Previous studies have suggested that postural control deficits are detected more accurately with dual-task testing than single-task testing. However, it is necessary to examine the clinimetric properties of dual-task testing before employing it in clinical and research settings.

Objective: To examine and compare the relative and absolute reliability of the Balance Error Scoring System (BESS), Tandem Gait Test (TGT), and Clinical Reaction Time (CRT) under single and dual-task conditions in uninjured active youth and young adults.

Study Design: Single-group, repeated-measures study.

Methods: Twenty-three individuals [9 female; median age 17 years] participated in the current study between December 1, 2017 and November 30, 2018. Data was collected in a physiotherapy clinic. Two raters assessed participants as they completed three trials of the BESS, TGT, and CRT under single and dual-task testing conditions twice within one day. The average of three trials was used to calculate intra-rater (between-session) and inter-rater (within-session) intraclass correlation coefficient (ICC), standard error of measurement (SEM), minimal detectable change (MDC), and Cohen's Kappa coefficient for tests as appropriate under both conditions. Bland-

Altman plots (mean difference and 95% limits of agreement) were used to assess for a systematic error associated with a learning effect.

Results: Under single-task testing, estimated ICCs, SEMs, MDCs, and Kappa coefficients ranged from 0.24 to 0.99, 0.3 to 23, 0.8 to 64, and 0.03 to 0.64, respectively. Under dual-task testing, estimated ICCs, SEMs, MDCs, and Kappa coefficients ranged from 0.70 to 0.99, 0.4 to 17, 1.1 to 47, and 0.39 to 0.83, respectively. A learning effect was identified for all tests under all conditions.

Conclusion: The BESS is the only clinical test that demonstrated acceptable reliability for clinical use under single-task testing conditions. The BESS, TGT, and CRT demonstrated acceptable reliability for clinical use under dual-task testing conditions. A practice session should be used to reduce the possible learning effect seen. Further studies examining sources of the systematic error observed are needed.

4.1 INTRODUCTION

Non-instrumented assessment of postural control is a common practice in clinical and on-field sport medicine, rehabilitation and training settings.[1] For example, the Balance Error Scoring System (BESS),[2] Tandem Gait Test (TGT),[3] and Clinical Reaction Time (CRT)[4] are frequently used in baseline pre-season testing and after concussion to examine static postural control, dynamic postural control, and reaction time, respectively.[5]

The clinimetric properties of the BESS, TGT, and CRT have been examined to varying degrees. The BESS involves three stances, double, single and tandem. Each stance takes 20 seconds to complete and is performed on both a firm and unstable surface. The intra- and inter-rater reliability of the BESS has been previously examined in uninjured children, youth, and adult athletes with observed intra-class correlation coefficient (ICC) ranging from 0.57 to 0.98.[2, 6-9] The BESS has also demonstrated varying degrees of criterion-related validity and concurrent validity in comparison to kinematic measures of postural sway in uninjured adult male ($r=0.3-0.79$, $p<0.01$)[10] and adolescent ($r = 0.54$, $p = 0.001$)[11] athletes. However, Quatman-Yates et al [12] suggested that the BESS may be limited for producing accurate assessments of postural control abilities in young athletes with concussion.

The TGT involves walking in a forward direction as accurately and quickly as possible down and back along a 38mm-wide three-meter line, with an alternate foot heel-to-toe gait. Despite the wide usage of the TGT for dynamic postural control assessment, it is difficult to synthesize the test's clinimetric properties as there is currently no standardized testing protocol. The intra- and inter-rater reliability of the TGT protocol described by Koyama et al [13] has been previously examined

in uninjured adults with ICCs ranging from 0.70 to 0.95. The TGT has also demonstrated evidence of concurrent-validity ($r > 0.67$, $p < 0.01$) with Timed Up and Go test scores in uninjured adults.[13]

Finally, the CRT involves catching a falling numbered-rod as quickly as possible. The drop distance is then converted to speed. The intra- and inter-rater reliability of the CRT has been previously examined in uninjured athletes with ICCs ranging between 0.74 and 0.76.¹⁴ The CRT has also demonstrated evidence of criterion-related validity with computerized reaction times ($r = 0.54$, p-value not provided) in uninjured athletes.[14]

When a more accurate assessment of postural control is needed, as in research settings, instrumented assessment of postural control using laboratory measures have been employed.[15]

Commonly used testing paradigms across studies involving instrumented assessments included single- and dual-task testing paradigms.[16-20] For single-task testing, examined individuals are asked to control their posture without performing a concurrent cognitive task. For dual-task testing, examined individuals are asked to control their posture while performing a concurrent cognitive task. These studies demonstrated that adding a concurrent cognitive task to a postural control task can provide important information about postural control impairments that may not be identified with single-task testing. [16-20] Further, a recent systematic review [21] reported that dual-task testing identified postural control impairments later in the recovery period following concussion than single-task testing. Although instrumented assessments are not clinically feasible given the time, cost and need for specialized equipment and technicians, the translation of the dual-task paradigm to clinical postural control testing through the addition of a cognitive task to tests such as the BESS,[22] TGT,[23] and CRT[14] may improve the robustness of clinical postural control assessment.

Before employing the dual-task BESS, TGT, and CRT in clinical or clinical research settings, it is necessary to examine their clinimetric properties (i.e., reliability and validity).[24] The primary objective of this study is to examine the relative and absolute reliability of the dual-task BESS, TGT and CRT in a sample of uninjured active youth and young adults. We hypothesized that dual-task testing would demonstrate acceptable reliability for clinical use. A secondary objective of this study was to compare the reliability of the BESS, TGT, and CRT under single-task versus dual-task testing.

4.2 METHODS

4.2.1 Design

This is a single-group, repeated-measures study examining the relative and absolute intra-rater (between-sessions) and inter-rater (within-session) reliability of three clinical tests of postural control under single and dual-task conditions. Relative reliability is the degree to which tested individuals maintain their position in a sample with repeated measurements. Absolute reliability, on the other hand, is the degree to which scores on repeated measurements vary for tested individuals.[25] Ethics approval (No: Pro00077091, Date: December 19, 2017) was acquired from the University of Alberta Health Research Ethics Board, and informed consent and/or assent was obtained from all participants prior to testing as appropriate.

4.2.2 Participants

Participants included a convenience sample of uninjured active individuals who were 13 – 24 years old. ‘Active’ was operationalized as Cincinnati Sports Activity Scale level one or two.[26] Participants were recruited between December 1, 2017 and November 30, 2018 from local sport

organizations and through advertisements, social media, and word of mouth. Participants were excluded if they were not active in recreational or competitive sport; suffered a concussion within the last 12 months; reported a lower extremity injury that resulted in time lost from recreational/sport activities for greater than one week within the last three months, an inner ear or sinus infection over the week prior to testing, an uncorrectable (i.e., neither with vision glasses nor contacts) vision condition at time of testing, a history of cognitive deficits including concentration abnormalities, history of attention deficit hyperactivity disorder; or were non-English speakers. Sample size was estimated based on guidelines provided by Walter et al.[27] Based on previously reported reliability of the BESS (ICC = 0.87),[6] twenty-one participants were needed for reliability analysis using two repetitions to achieve a power of 80% with alpha of 0.05 for clinically acceptable reliability (ICC =0.6).[28]

4.2.3 Procedures

All data were collected at a private physiotherapy clinic over two testing sessions. Two physical therapists (TM, CI) rated individual participant's performance of three trials of the BESS, TGT and CRT under single and dual-task conditions. Each of the two physical therapists had more than five years of experience administering the BESS, TGT, and CRT in clinical settings. They met before data collection to review and discuss the test instructions and scoring procedures. At testing session one, participants were asked to complete a study questionnaire that gathered information about demographics and medical history. Participants were then familiarized with testing procedures before data collection started. Next, the two physical therapists independently rated and recorded individual participant's performance simultaneously to evaluate the inter-rater reliability of the BESS, TGT and CRT under single and dual-task conditions. One physical

therapist (TM) provided tests' instructions for all participants. Participants performed the BESS, TGT, and then CRT under both the single- and dual-task testing conditions, with the single-task testing condition performed first. Participants were given a one-minute rest between trials to minimize fatigue. Consistent with a guideline for reliability research design,[29] one of the physical therapists (TM) repeated testing of all participants for all tasks under all conditions either later on the same day or the following day to evaluate the intra-rater reliability. The BESS, TGT, and CRT were administered in the same order as in session one. The two physical therapists followed a specific script for the BESS, TGT, and CRT to standardize test instruction between raters and testing sessions. No feedback regarding testing outcomes was given to participants or shared between physical therapists during or after testing.

4.2.4 Outcome Measures

Demographics and medical history. A questionnaire adapted from the Sports Concussion Assessment Tool–5th edition was used to collect information on participants' demographics (i.e., sex, age, and the primary played sport) and medical history (i.e., history of previous concussions and current medications).[30]

The Balance Error Scoring System (see Figure 1). The BESS is used to evaluate static postural control ability and involves three stances, double, single and tandem. Each stance takes 20 seconds to complete and is performed on both a firm and unstable surface. A stance in the BESS is scored based on the number of errors a participant commits, with one point given for each error. Possible errors include lifting the hands off the iliac crests, opening the eyes, stepping, stumbling, falling, remaining out of position for more than 5 seconds, moving the hip into more than 30 degrees of flexion or abduction, or lifting the forefoot or heel. A maximum of 10 points per stance is allowed.

If a participant is unable to maintain a stance for 5 seconds, a maximum score of 10 was given for that stance. The total score of the BESS ranges from 0 to 60, and is calculated as the sum of the error points given for each of the six stances.[10] For the dual-task condition, participants were asked to subtract by seven from a randomly assigned number while performing the BESS. This cognitive task is frequently used in dual-task postural control assessment.[16]

The Tandem Gait Test (see Figure 2). The TGT is used to evaluate dynamic postural control and involves walking in a forward direction as fast and accurately as possible down and back along a 38mm-wide three-meter line using an alternate foot heel-to-toe gait. During the TGT, the administrator notes whether the evaluatee steps off the line, separates his/her heel and toe, or touches the examiner or an object for support.[30] We collected the time in seconds required for participants to complete the test (i.e., TGT-Time), as well as the participant's ability to successfully complete the test (i.e., TGT-Error, pass/fail). For the dual-task condition, participants were asked to spell-out a five-letter word backward while performing the TGT.[16]

The Clinical Reaction Time (see Figure 3).The CRT is used to evaluate reaction time and requires a participant to sit on a chair with the dominant hand resting on a flat, horizontal table. During the CRT, the examiner vertically suspends a rigid 80cm cylinder coated in high-friction tape, marked in $\frac{1}{2}$ cm increments, and affixed to a weighted disk at one end. At predetermined, random time intervals ranging from 4 to 15 seconds, the examiner releases the apparatus and the participant catches it as quickly as possible. The distance the apparatus falls in centimeters is recorded by measuring from the top of the disk to the most superior aspect of the participant's hand. This distance is then converted to clinical reaction time, in milliseconds, using the formula for a free body falling under the influence of gravity ($d = \frac{1}{2} gt^2$; where d = distance, $g = 9.8 \text{ m/s}^2$,

and $t = \text{time}$. [31] For the dual-task condition, participants were asked to verbally spell a five-letter word backward while waiting for the testing apparatus to fall. [16]

4.2.5 Analysis

Appropriate descriptive statistics were used to summarize all outcomes. For postural control tests with continuous outcomes including the BESS, TGT-Time, and CRT, ICC_{2,1} with 95% confidence intervals (CI) were calculated based on trial one and the average of three trials to estimate relative intra-rater and inter-rater reliability. [29] ICC estimates were interpreted as acceptable if they were ≥ 0.60 . [28] Standard error of measurement (SEM), [24] and minimal detectable changes at the 95% confidence level (MDC₉₅) based on trial one and average of three trials were calculated to estimate absolute intra-rater and inter-rater reliability. [32] SEM was calculated as $\text{SEM} = \text{pooled Standard Deviation} \times (\sqrt{1 - \text{ICC}})$. MDC₉₅ was calculated as $\text{MDC}_{95} = 1.96 \times \text{SEM} \times \sqrt{2}$. Bland-Altman plots (i.e., mean difference and 95% limits of agreement) were used to assess for systematic bias between the first and third trial at session one, and between sessions using the average of three trials at session one minus the average of three trials at session two of all tests and conditions using data from rater one (XX). [33] For TGT-Error, Cohen's Kappa coefficients (κ ; 95% CI) for three trials were calculated to estimate intra-rater and inter-rater agreement. [34] All analyses were performed using IBM SPSS 25 for Windows (Armonk, New York).

4.3 RESULTS

4.3.1 Participants

Of the 40 individuals who expressed interest in participating in the study, four did not meet the inclusion criteria (history of concussion within the year prior to testing), three declined to participate (time constraints), and nine did not respond to communications leaving a study sample of 24 participants. One participant withdrew after providing consent, but prior to testing for undisclosed personal reasons. The recruited sample included 23 participant. The median age of participants was 17 years (ranging from 13 to 24), and 39% (n=9) were female. The majority (65.2%) of participants played hockey, ringette, or soccer. Nine of the participants (39%) had suffered a concussion greater than one year prior to testing. One participant (4.3%) reported current use of antibiotics for acne.

All participants (n=23) completed two sessions of testing. Only one participant attended the second session on the following day, while 22 participants (95%) attended the second session within 4 hours after testing session one. Summary statistics for participants' performance on the BESS, TGT-Time, TGT-Error, and CRT are summarized by session, rater, and task in Table 1.

4.3.2 *Relative Reliability*

Table 2 summarizes intra- and inter-rater ICC's (95% CI) estimates for the BESS, TGT-Time, and CRT under single- and dual-task conditions calculated using trial one only, while Table 3 presents these estimates calculated using an average of all three trials. Inter-rater reliability ICC for the CRT (single-task) based on trial one could not be estimated due to an absence of variance in scores between raters (i.e., Negative ICC values obtained).[35] All of the ICCs calculated based on the average of three trials were > 0.60 for dual-task testing across tasks and conditions. Fifty-percent of the ICCs calculated based on the average of three trials were > 0.60 for single-task testing across tasks and conditions. Table 4 presents intra- and inter-rater Cohen's κ estimates for the TGT-Error

under both single- and dual-task conditions. In general, the dual-task condition provided higher Cohen's κ estimates compared to single-task conditions.

4.3.3 Absolute Reliability

Table 2 summarizes intra- and inter-rater SEM and MDC estimates for all tests under single- and dual-task conditions calculated using trial one only, while Table 3 presents these estimates calculated using an average of all three trials. Overall, administering the BESS, TGT-Time, and CRT three times and averaging the three trials provided lower SEMs and MDCs under both single- and dual-task testing. Based on the average of three trials, dual-task testing provided lower SEMs and MDCs for the BESS, TGT-Time, and CRT compared to single-task testing.

Table 5 summarizes the mean difference (SD) and 95% limits of agreement associated with Bland-Altman plots for between trials and between sessions of all tests and conditions. There was a positive shift in the difference scores related to single- and dual-task BESS, TGT-Time, and CRT between trials and between sessions (Figure 4 presents an example). Appendix 3 shows Bland-Altman plots for between trials and between sessions of all tests and conditions. The positive shift observed remained after stratifying the analysis by sex and age.

4.4 DISCUSSION

This novel research demonstrates that averaging observations across three trials produces clinically acceptable relative and absolute intra-rater and inter-rater reliability for the BESS, TGT-Time, and CRT in uninjured active youth and young adults. This was true in in both dual- and most single-task conditions. Given this and the potential learning effect observed, we recommend that a practice session be administered prior to performing the BESS, TGT and CRT regardless of dual-

or single-task conditions. Further, dual-task testing demonstrated higher relative and absolute reliability compared to single-task testing.

As there is a paucity of evidence about the reliability of dual-task clinical postural control testing direct comparisons to previous studies are limited. Ross et al [22] reported higher estimates of inter-session reliability (ICC = 0.81, SEM = 1.87) based on one trial of the dual-task BESS in a sample of uninjured college students. On the other hand, a comparable estimate of inter-rater reliability (ICC = 0.87) based on repeated administrations of the dual-task CRT has been reported in a sample of uninjured athletes.[14] To our knowledge, there are no previous studies examining the reliability of TGT under dual-task condition.

There are substantially more studies examining the reliability of single-task clinical postural control testing compared to dual-task testing.[2, 7, 9, 13, 14] Compared to the current study, Finnoff et al [7] reported a higher inter-rater reliability estimate (MDC=9.4) based on one trial of the single-task BESS. It is difficult to hypothesize the reasons for this difference as the authors did not report participant demographics, or a confidence interval for the MDC estimate. Similarly, Schneiders et al [36] reported higher intra-rater reliability estimates based on one trial (ICC=0.54) and the average of three trials (ICC=0.70) of the single-task TGT-Time in a sample of uninjured individuals (mean age=22.2±3.8 years). Possible explanations for this difference may be the younger sample and the systematic error in the TGT-Time identified in the current study, which reduced the stability of the TGT-Time between testing sessions. One explanation for the systematic error in the TGT-Time for between-sessions measurements is a learning effect. Specifically, participants tended to walk faster in session two compared to session one (1.8 seconds in maximum mean difference; see Table 5). Further studies comparing the systematic error of the single-task

TGT-Time in adolescent versus adults are needed. Finally, Eckner et al [14, 37] reported higher intra-rater (ICC=0.76) and inter-rater (ICC=0.74) reliability estimates based on repeated administration of the single-task CRT in samples of uninjured individuals (age range 8-30 years). The difference may be attributed to the limited number of repetitions averaged in the current study (three trials) compared to the later (eight repetitions), which may have contributed to greater between-raters variability. To our knowledge, there are no previous studies examining the reliability of single-task TGT-Error.

Our analyses suggest that repeated administration of the dual-task BESS, TGT-Time, and CRT are associated with a learning effect. Specifically, participants tended to commit fewer errors on the BESS, walk faster on the TGT, and react faster on the CRT in trial three compared to trial one, and in session two compared to session one (see Table 5). Further studies are needed to determine the effect of different sources of variance within these tests, potentially informed by generalizability theory. Examples of the sources of variance include age, sex, number of trials, fatigue, and footwear.[38-41] Our analyses, on the other hand, further supports previous investigations suggesting that repeated administration produces a learning effect with the single-task BESS,[38] TGT-Time,[13] and CRT (mainly with three trials).[42] For instance, participants performance on the BESS, TGT-Time, and CRT enhanced in trial three compared to trial one, and in session two compared to session one (see Table 5).

In a previous systematic review on dual-task assessments for use in concussion management, Register-Mihalik and colleagues [16] observed that dual-task testing in some cases was more reliable than single-task testing. While our findings are consistent with this observation, the exact reason for this is not clear. We speculate this may represent higher measurement consistency under

dual-task conditions, but could also be attributable to higher between-participant variability under dual-task compared to single-task condition (see Table 1).

4.4.1 Clinical Recommendations

Adding a cognitive task to the BESS, TGT, and CRT enhanced the tests' reliability without compromising ease of administration or time in the clinic. Based on our analyses, the dual-task BESS, TGT-Time, and CRT demonstrated acceptable reliability for clinical use. Clinicians may consider interpreting the mean score from three administrations of dual-task clinical postural control testing to obtain the most reliable scores. Our data suggests that there is a 95% probability that a change of four points on the BESS, 3.3 seconds on the TGT-Time, and 30 milliseconds on the CRT is due to a change in postural stability rather than variability in trial scores by a single rater (based on the average score of three repetitions by the same rater). Further, that there is a 95% probability that a change of four points on the BESS, 1.1 seconds on the TGT-Time, and 47 milliseconds on the CRT is due to a change in postural stability rather than variability in scores between raters (based on the average score of three repetitions by the same rater). For the dual-task TGT-Error, clinicians may consider interpreting the score from trial three to obtain the most reliable intra- and inter-rater scores. Finally, multiple tests exposures may lead to an improved postural control due to a learning effect. Clinicians should implement a practice session before final testing to eliminate the learning effect seen.

4.4.2 Strengths and Limitations

The main strength of the current study is that both intra-rater and inter-rater reliability was evaluated using both relative (i.e., ICC) and absolute (i.e., SEM and MDC) reliability

methodologies. That being said, this study has some limitations. Specifically, the order of tasks and testing conditions administration was not random, which added standardization but may have contributed to the observed learning effect. However, we recommend that clinicians implement a practice session before final testing to reduce the potential learning effect observed. Further, we recruited only uninjured participants, which limits the generalizability of our findings to injured youth and young adults. As the majority (61%) of the recruited sample were males, the generalizability of our findings to females may be limited. Similarly, the generalizability of our findings to different sports may be limited due to the fact that the majority (65.2%) of the recruited sample played hockey, ringette, or soccer. Individuals who were recruited may be at different levels of maturation, which may contribute to the variability of our results. Finally, the precision of the single-task TGT-Time, single- and dual-task TGT-Error, and dual-task CRT was low, which may be attributable to test instability and/or the small and homogenous sample recruited.

The current study is a first step toward establishing a line of research evaluating the clinimetric properties of clinical dual-task testing paradigms for identifying postural control deficits in neurologically impaired adolescents and young adults. Future studies examining the reliability, validity, and responsiveness of the dual-task BESS, TGT, and CRT are needed in larger and more representative samples of neurologically impaired adolescents and young adults.

4.5 CONCLUSION

Assessment of postural control is a common practice in clinical and training settings. Studies involving instrumented assessments have demonstrated that adding a concurrent cognitive task to a postural control task can provide important information about postural control impairments that may not be identified with single-task testing. As the instrumented assessment of postural control

is not clinically feasible, it has been suggested that adding a cognitive task to the commonly used BESS, TGT, and CRT may improve the robustness of clinical postural control assessment. The current study suggests that administering the dual-task BESS, TGT, and CRT three times and averaging the three trials provided acceptable reliability for clinical use. Further, dual-task testing has higher relative and absolute reliability compared to single-task testing.

4.6 REFERENCES

- 1.Huxham FE, Goldie PA, Patla AE. Theoretical considerations in balance assessment. *Aust J Physiother.* 2001;47(2):89-100.
- 2.Bell DR, Guskiewicz KM, Clark MA, Padua DA. Systematic review of the Balance Error Scoring System. *Sports Health.* 2011;3(3):287-95.
- 3.Margolesky J, Singer C. How tandem gait stumbled into the neurological exam: a review. *J Neurol Sci.* 2018;39(1):23-9.
- 4.Council NR, Youth CoS-RCi. Sports-related concussions in youth: improving the science, changing the culture: National Academies Press; 2014.
- 5.McCrory P, Meeuwisse W, Dvorak J, Aubry M, Bailes J, Broglio S, et al. Consensus statement on concussion in sport-the 5(th) International Conference on Concussion in Sport held in Berlin, October 2016. *Br J Sports Med.* 2017;51(11):838-47.
- 6.Murray N, Salvatore A, Powell D, Reed-Jones R. Reliability and validity evidence of multiple balance assessments in athletes with a concussion. *J Athl Train.* 2014;49(4):540-9.
- 7.Finnoff JT, Peterson VJ, Hollman JH, Smith J. Intrarater and interrater reliability of the Balance Error Scoring System (BESS). *PM R.* 2009;1(1):50-4.
- 8.Cushman D, Hendrick J, Teramoto M, Fogg B, Bradley S, Hansen C. Reliability of the balance error scoring system in a population with protracted recovery from mild traumatic brain injury. *Brain Inj.* 2018;32(5):569-74.

9. Hansen C, Cushman D, Chen W, Bounsanga J, Hung M. Reliability testing of the balance error scoring system in children between the ages of 5 and 14. *Clin J Sport Med.* 2017;27(1):64.
10. Riemann BL, Guskiewicz KM, Shields EW. Relationship between clinical and forceplate measures of postural stability. *J Sport Rehabil.* 1999;8(2):71-82.
11. Alsalaheen BA, Haines J, Yorke A, Stockdale K, P. Broglio S. Reliability and concurrent validity of instrumented balance error scoring system using a portable force plate system. *Phys Sportsmed.* 2015;43(3):221-6.
12. Quatman-Yates C, Hugentobler J, Ammon R, Mwase N, Kurowski B, Myer GD. The utility of the balance error scoring system for mild brain injury assessments in children and adolescents. *Phys Sportsmed.* 2014;42(3):32-8.
13. Koyama S, Tanabe S, Itoh N, Saitoh E, Takeda K, Hirano S, et al. Intra- and inter-rater reliability and validity of the tandem gait test for the assessment of dynamic gait balance. *Eur J Physiother.* 2018;20(3):135-40.
14. Eckner JT, Richardson JK, Kim H, Joshi MS, Oh YK, Ashton-Miller JA. Reliability and criterion validity of a novel clinical test of simple and complex reaction time in athletes. *Percept Mot Skills.* 2015;120(3):841-59.
15. Muro-de-la-Herran A, Garcia-Zapirain B, Mendez-Zorrilla A. Gait analysis methods: an overview of wearable and non-wearable systems, highlighting clinical applications. *Sensors.* 2014;14(2):3362-94.

16. Register-Mihalik JK, Littleton AC, Guskiewicz KM. Are divided attention tasks useful in the assessment and management of sport-related concussion? *Neuropsychol Rev.* 2013;23(4):300-13.
17. Woollacott M, Shumway-Cook A. Attention and the control of posture and gait: a review of an emerging area of research. *Gait Posture.* 2002;16(1):1-14.
18. Fraizer EV, Mitra S. Methodological and interpretive issues in posture-cognition dual-tasking in upright stance. *Gait Posture.* 2008;27(2):271-9.
19. Yogev-Seligmann G, Hausdorff JM, Giladi N. The role of executive function and attention in gait. *Mov Disord.* 2008;23(3):329-42; quiz 472.
20. Al-Yahya E, Dawes H, Smith L, Dennis A, Howells K, Cockburn J. Cognitive motor interference while walking: a systematic review and meta-analysis. *Neurosci Biobehav Rev.* 2011;35(3):715-28.
21. Manaseer TS, Gross DP, Dennett L, Schneider K, Whittaker JL. Gait deviations associated with concussion: A Systematic Review [published online ahead of print, 2017 Nov 21]. *Clin J Sport Med.* 2017;10.1097/JSM.0000000000000537. doi:10.1097/JSM.0000000000000537.
22. Ross LM, Register-Mihalik JK, Mihalik JP, McCulloch KL, Prentice WE, Shields EW, et al. Effects of a single-task versus a dual-task paradigm on cognition and balance in healthy subjects. *J Sport Rehabil.* 2011;20(3):296-310.
23. Howell DR, Osternig LR, Chou LS. Single-task and dual-task tandem gait test performance after concussion. *J Sci Med Sport.* 2017;20(7):622-6.

24. Portney LG, Watkins MP. Foundations of clinical research: applications to practice. 2nd ed. NJ: Prentice Hall Upper Saddle River; 2000.
25. Atkinson G, Nevill AM. Statistical methods for assessing measurement error (reliability) in variables relevant to sports medicine. *Sports Med.* 1998;26(4):217-38.
26. Barber-Westin SD, Noyes FR, McCloskey JW. Rigorous statistical reliability, validity, and responsiveness testing of the Cincinnati knee rating system in 350 subjects with uninjured, injured, or anterior cruciate ligament-reconstructed knees. *Am J Sports Med.* 1999;27(4):402-16.
27. Walter SD, Eliasziw M, Donner A. Sample size and optimal designs for reliability studies. *Stat Med.* 1998;17(1):101-10.
28. Anastasi A. *Psychological Testing.* 6th ed. New York: Macmillan;1988.
29. Koo TK, Li MY. A guideline of selecting and reporting intraclass correlation coefficients for reliability research. *J Chiropr Med.* 2016;15(2):155-63.
30. Echemendia RJ, Meeuwisse W, McCrory P, Davis GA, Putukian M, Leddy J, et al. The Sport Concussion Assessment Tool 5th Edition (SCAT5): background and rationale. *Br J Sports Med.* 2017;51(11):848-50.
31. Eckner JT, Whitacre RD, Kirsch NL, Richardson JK. Evaluating a clinical measure of reaction time: an observational study. *Percept Mot Skills.* 2009;108(3):717-20.
32. Roebroeck ME, Harlaar J, Lankhorst GJ. The application of generalizability theory to reliability assessment: an illustration using isometric force measurements. *Phys Ther.* 1993;73(6):386-95.

33. Bland JM, Altman D. Statistical methods for assessing agreement between two methods of clinical measurement. *The Lancet*. 1986;327(8476):307-10.
34. McHugh ML. Interrater reliability: the kappa statistic. *Biochem Med (Zagreb)*. 2012;22(3):276-82.
35. Loosveldt G. *International handbook of survey methodology*: Taylor & Francis Group/Lawrence Erlbaum Associates; 2008.
36. Schneiders AG, Sullivan SJ, Gray AR, Hammond-Tooke GD, McCrory PR. Normative values for three clinical measures of motor performance used in the neurological assessment of sports concussion. *J Sci Med Sport*. 2010;13(2):196-201.
37. Eckner JT, Kutcher JS, Richardson JK. Between-seasons test-retest reliability of clinically measured reaction time in National Collegiate Athletic Association Division I athletes. *J Athl Train*. 2011;46(4):409-14.
38. Valovich TC, Perrin DH, Gansneder BM. Repeat administration elicits a practice effect with the balance error scoring system but not with the standardized assessment of concussion in high school athletes. *J Athl Train*. 2003;38(1):51.
39. Wilkins JC, Valovich McLeod TC, Perrin DH, Gansneder BM. Performance on the Balance Error Scoring System decreases after fatigue. *J Athl Train*. 2004;39(2):156-61.

40.Schneiders AG, Sullivan SJ, Kvarnstrom J, Olsson M, Yden T, Marshall S. The effect of footwear and sports-surface on dynamic neurological screening for sport-related concussion. *J Sci Med Sport*. 2010;13(4):382-6.

41.Broglio SP, Zhu W, Sapiariz K, Park Y. Generalizability theory analysis of balance error scoring system reliability in healthy young adults. *J Athl Train*. 2009;44(5):497-502.

42.Nguyen CN, Clements RN, Porter LA, Clements NE, Gray MD, Baker RT. Examining practice and learning effects with serial administration of the clinical reaction time test in healthy young athletes. *J Sport Rehabil*. 2018;28(6):558-63.

4.7 TABLES

Table 4-1: Descriptive Statistics for the BESS, TGT, and CRT by Session, Rater, and Task

Table 1: Descriptive Statistics for the BESS, TGT, and CRT by Session, Rater, and Task (n=23)

Condition	Trial	Session 1, Rater 1				Session 1, Rater 2				Session 2, Rater 1			
		BESS errors	TGTT second	TGTE % pass	CRT ms	BESS errors	TGTT second	TGTE % pass	CRT ms	BESS errors	TGTT second	TGTE % pass	CRT ms
ST	Trial 1	16 (24)	19 (25)	69	260 (90)	18 (26)	20 (24)	43	270 (150)	15 (30)	16 (15)	73	280 (140)
	Average of 3 trials	14 (26)	19 (14)	73	250 (70)	16 (29)	19 (14)	49	260 (110)	15 (30)	16 (10)	76	250 (90)
	Trial 1	14 (34)	20 (25)	78	240 (110)	14 (31)	19 (24)	82	270 (200)	15 (30)	19 (27)	78	280 (170)

DT	Average	13	20	84	250	14	21	79	260	14	18	77	240
	of 3 trials	(30)	(23)		(110)	(27)	(23)		(140)	(30)	(23)		(100)

Note. BESS: Values are presented as median (range; defined as largest value minus smallest value) or percentage. BESS: Balance Error Scoring System, CRT: clinical reaction time, DT: dual-task, ms: milliseconds, ST: single-task, TGTE: pass/fail in the Tandem Gait Test, TGTT: time required to complete the Tandem Gait Test.

Table 4-2: Intra- and Inter-rater Reliability Estimates for the BESS, TGT, and CRT by Session, Rater, and Task

Table 2: Intra- and Inter-rater Reliability Estimates for the BESS, TGT, and CRT by Session, Rater, and Task (n=23)

	Estimates Based on Trial 1					
	Intra-rater			Inter-rater		
	ICC (2,1) (95% CI)	SEM	MDC	ICC (2,1) (95% CI)	SEM	MDC
BESS-ST errors	0.72 (0.45,0.87)	2.4	6.6	0.89 (0.76,0.95)	1.8	4.9
BESS-DT errors	0.62 (0.31,0.82)	2.8	7.8	0.95 (0.89,0.98)	1.7	4.7
TGTT-ST second	0.20 (0,0.53)	3.8	10.5	0.98 (0.97,0.99)	0.7	1.9
TGTT-DT second	0.81 (0.61,0.91)	2.4	6.6	0.94 (0.87,0.97)	1.4	3.8
CRT-ST millisecond	0.10 (0,0.44)	28	77	-	-	-
CRT-DT millisecond	0.31 (0.01,0.62)	26	72	0.40 (0.00,0.70)	32	88

Note. (-): Values that could not be calculated due to low examiner variance, BESS: Balance Error Scoring System, CI: confidence interval, CRT: clinical reaction time, DT: dual-task, ICC: intra-class correlation coefficient, MDC: minimal detectable change, SEM: standard error of measurement, ST: single-task, TGTT: time required to complete the Tandem Gait Test.

Table 4-3: Intra- and Inter-rater Reliability Estimates for the BESS, TGT, and CRT by Session, Rater, and Task

Table 3: Intra- and Inter-rater Reliability Estimates for the BESS, TGT, and CRT by Session, Rater, and Task (n=23)

Estimates Based on the Average of Three Trials						
	Intra-rater			Inter-rater		
	ICC (2,1) (95% CI)	SEM	MDC	ICC (2,1) (95% CI)	SEM	MDC
BESS- ST errors	0.94 (0.87,0.97)	1.5	4.3	0.96 (0.88,0.98)	1.2	3.5
BESS- DT errors	0.94 (0.86,0.97)	1.4	3.8	0.98 (0.97,0.99)	1.1	3
TGTT- ST second	0.54 (0,0.79)	2	5.5	0.99 (0.99,0.99)	0.3	0.8
TGTT- DT second	0.94 (0.83,0.98)	1.2	3.3	0.99 (0.98,0.99)	0.4	1.1
CRT- ST millisecond	0.59 (0.04,0.82)	13	36	0.24 (0,0.68)	23	64
CRT- DT millisecond	0.90 (0.77,0.96)	11	30	0.70 (0.29,0.87)	17	47

Note. BESS: Balance Error Scoring System, CI: confidence interval, CRT: clinical reaction time, DT: dual-task, ICC: intra-class correlation coefficient, MDC: minimal detectable change, SEM: standard error of measurement, ST: single-task, TGTT: time required to complete the Tandem Gait Test.

Table 4-4: Kappa Statistic (κ) Estimates for the Pass/Fail Task in the Tandem Gait Test

Table 4: Kappa Statistic (κ) for the Pass/Fail Task in the Tandem Gait Test (n=23)

	Intra-rater			Inter-rater		
	Trial 1	Trial 2	Trial 3	Trial 1	Trial 2	Trial 3
	κ (95% CI)	κ (95% CI)	κ (95% CI)	κ (95% CI)	κ (95% CI)	κ (95% CI)
Single- Task	0.03 (0,0.52)	0.23 (0,0.80)	0.64 * (0.1,1)	0.17 (0,0.52)	0.28 (0,0.68)	0.37 * (0.09,0.78)
Dual- Task	0.23 (0,0.80)	0.32 (0,0.91)	0.40 * (0.01,0.96)	0.58 * (0.01,1.00)	0.59 * (0.01,1.00)	0.83 * (0.13,1.00)

Note. * $p < 0.05$, CI: confidence interval.

Table 4-5: Summary Data Associated with Bland-Altman Plots for the BESS, TGT, and CRT under Single-Task and Dual-Task Testing Conditions

Table 5: Summary Data Associated with Bland-Altman Plots

Test	Mean Difference	95% LOA	Mean Difference	95% LOA
	(SD) T1 to T3	T1 to T3	(SD) S1 to S2	S1 to S2
BESS-ST errors	2.5 (6.3)	-9.8 to 14.8	0.2 (2.2)	-4.2 to 4.5
BESS-DT error	2.1 (7.1)	-11.7 to 15.9	0.1 (3.5)	-6.8 to 6.9
TGTT-ST second	2.8 (3.9)	-4.8 to 10.3	1.8 (3.2)	-4.5 to 8.3
TGTT-DT second	1.3 (2.3)	-3.3 to 5.9	1.2 (1.9)	-2.7 to 5.1
CRT-ST milliseconds	3.0 (29.6)	-54.9 to 61.0	4.3 (23)	-40.9 to 49.6
CRT-DT milliseconds	6.5 (26.0)	-44.5 to 57.5	0.8 (17)	-33.0 to 34.7

Note. BESS: Balance Error Scoring System, CRT: clinical reaction time, DT: dual-task, LOA: limits of agreement, S: session, SD: standard deviation, ST: single-task, TGTT: time required to complete the Tandem Gait Test, T: trial

4.8 FIGURES

Figure 4-1: The Balance Error Scoring System

Figure 1: The Balance Error Scoring System. Top row, firm surface condition. Bottom row, soft surface condition. Left column, parallel stance. Middle column, single-leg stance. Right column, tandem stance.



Figure 4-2: The Tandem Gait Test

Figure 2: The Tandem Gait Test. (a) Starting point. (b) Heel-to-toe walking. (c) Turning. (d) heel-to-toe walking back to the starting point.



Figure 4-3: The Clinical Reaction Time Test

Figure 3: The Clinical Reaction Time Test. (a) Demonstration of the starting athlete and tester positioning. (b) Demonstration of the post-drop athlete and tester positioning.

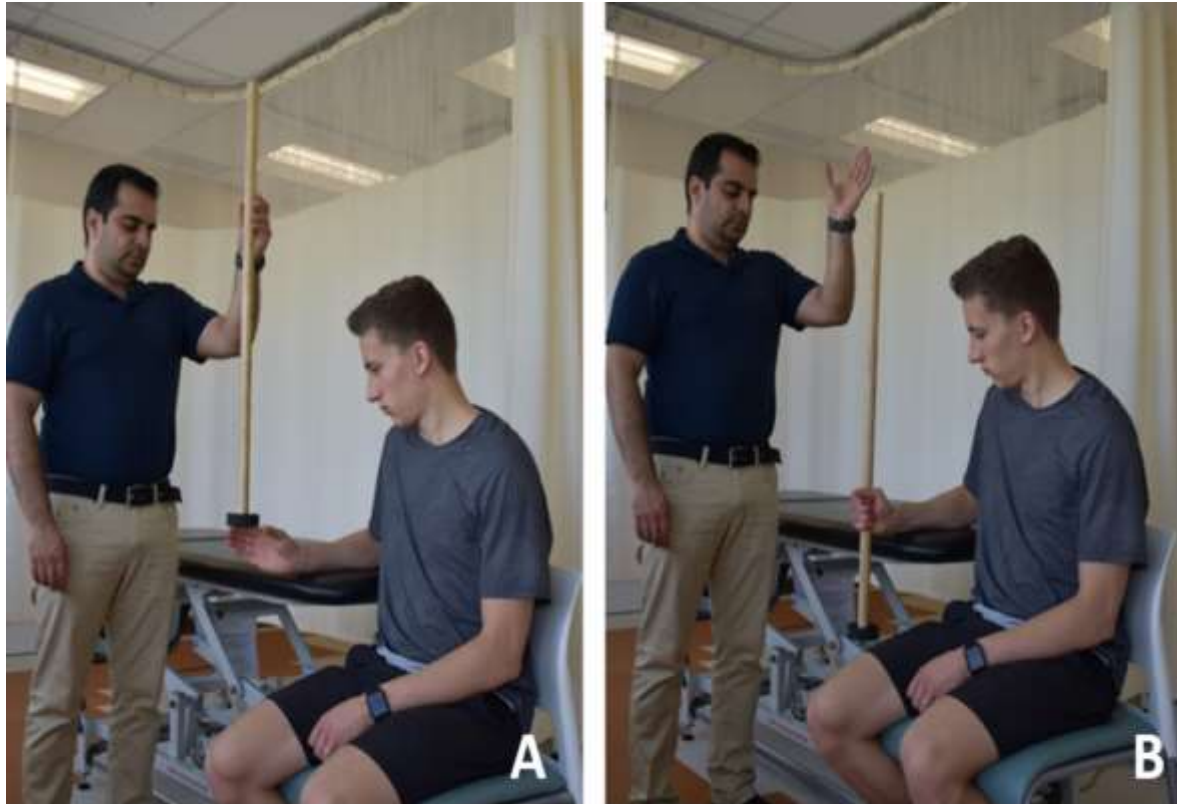
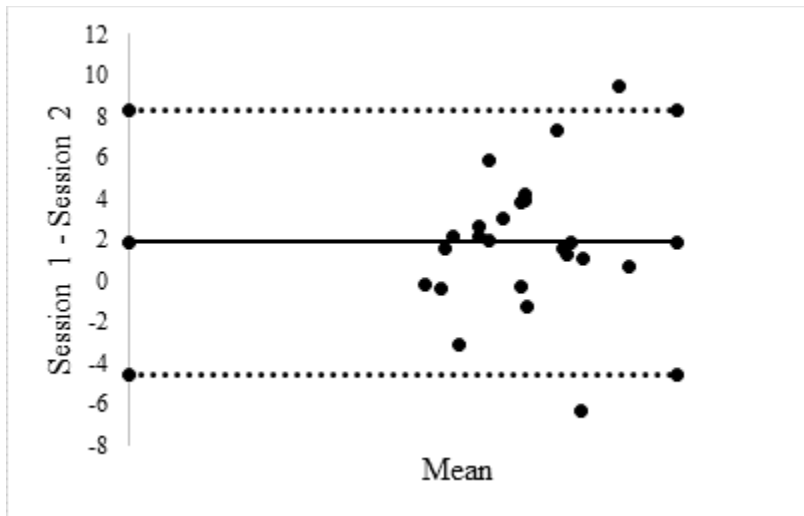

Figure 4-4: Bland-Altman plot of the Tandem Gait Test

Figure 4. Bland-Altman plot of the difference in the single-task Tandem Gait Test (seconds) between sessions one and two against the mean difference. The solid horizontal line represents the mean difference. The dashed horizontal lines represent the 95% upper and lower limits of agreement.



CHAPTER 5- POSTURAL CONTROL ASSESSMENT FOLLOWING SPORT-RELATED CONCUSSION: THE DEVELOPMENT AND RELIABILITY OF A NEW SPORT-SPECIFIC TEST

ABSTRACT

Background: Sport-related concussion can be associated with impaired postural control. Currently, there is a lack of a standardized sport-related postural control test that can be used to examine postural control recovery status following sport-related concussion. This study aimed to develop a sport-related postural control test that is appropriate for SRC, and evaluate its reliability (inter and intra) in a sample of uninjured active youth and young adults.

Methods: The sport-related postural control test (consisting of two components) was developed using the scale development framework of Johnson and Morgan. Two raters independently assessed 23 uninjured active adolescent and young adults [40% female; median age 17 years] during three trials performed in session one. One rater repeated the assessment of all participants later on the same day (session two). The average test component's scores across trials were used to calculate intra-rater (between-session) and inter-rater (within-session) intraclass correlation coefficient (ICC), standard error of measurement (SEM), minimal detectable change (MDC), and Cohen's Kappa coefficient (k) as appropriate. Bland-Altman plots were used to assess for systematic error.

Results: The 'Turn and Go' and 'Lateral Shuffle' components were developed. Estimated ICCs, SEMs, MDCs, and k for the two components ranged from 0.85 to 0.97, 0.3 to 0.7, 0.9 to 2.0, and 0.23 to 0.90, respectively. Participants' performance on both components improved from trial one

to trial three (mean difference ranged from 0.54 to 0.95 seconds), which may represent a learning effect.

Conclusion: The ‘Turn and Go’ and ‘Lateral Shuffle’ components of the sport-related postural control test demonstrated reliability in uninjured active youth and young adults. Future studies examining their psychometric properties in injured active youth and young adults are required before widespread use in clinical settings.

5.1 INTRODUCTION

By definition, postural control is a complex motor task that requires continuous interaction between multiple systems.[1] The underlying systems include sensory strategies, control of dynamics, movement strategies, cognitive contributions, orientation in space, and biomechanical elements (see Table 3 – 1 for definitions of each system).[2, 3] Postural control impairments may result from deficits in one or more of the underlying systems due to pathologies and/or injuries that affect the brain. Examples include Parkinson’s disease,[4] traumatic brain injuries,[1] and sport-related concussion (SRC).[2] Sport-related concussion is the focus of this article.

SRC is defined as a traumatic brain injury induced by a biomechanical force.[5] As a complex injury, SRC can be associated with deficits in several underlying systems of postural control including sensory integration, control of dynamics, and movement strategies (reaction time, the minimal time required to respond to a stimulus).[1, 5, 6] Hence, it is essential that postural control status is assessed following SRC to understand changes that occur following injury. Understanding how postural control changes with recovery can also inform return-to-play (RTP) decisions.[5] Clinically, full postural control recovery following SRC is defined as a return to normal postural control levels.[5] According to the current model of best practice, this is established by comparing an injured athlete’s postural control ability to pre-injury (baseline) values.[5] The most commonly used clinical assessments of postural control following SRC include the Balance Error Scoring System (sensory integration),[5] Tandem Gait Test (control of dynamics),[5] and Clinical Reaction Time (reaction time).[7]

While these test are clinically feasible, they do not assess the ability to control posture while performing specialized movements involved in sport (sport-related movements).[8] Consequently, injured athletes may be cleared for RTP despite ongoing postural control impairments,[9] which may increase the risk of future injury.[10] To overcome this limitation, there has been a call for sport-related postural control tests that can be incorporated into the multifaceted assessment following SRC.[8] The purpose of this study was to develop a sport-related postural control test that is appropriate for SRC, and evaluate its reliability (inter and intra) in a sample of uninjured active youth and young adults.

5.2 METHODS

The sport-related postural control test was developed using the scale development framework of Johnson and Morgan.[11] Intra-rater (between-session) and inter-rater (within-session) relative and absolute reliability of the components of the final test were assessed in a sample of uninjured active individuals. Ethics approval (No: Pro00077091, Date: December 19, 2017) was acquired from the University of Alberta Health Research Ethics Board. Participants provided written consent and/or assent prior to data collection as appropriate.

According to the Johnson and Morgan framework, scale development involves five steps: (1) defining the measurement construct; (2) generating a preliminary item pool through literature review and discussion with experts; (3) item pool review by the research team and content experts; (4) pilot testing with participants/patients; and (5) dissemination of the developed tool.¹¹ As this framework was originally designed for the development of self-report survey scales, it was adapted

for the postural control test (i.e., instead of generating a pool of potential survey items, we focused on generating a pool of clinical tests).

5.2.1 Defining the Measurement Construct

We informally reviewed the scientific literature to identify the underlying systems of postural control that can be affected following SRC. Articles were assembled through PubMed and Google Scholar searches using the combinations of the following terms: “concussion”, “traumatic brain injury”, “balance”, “postural control”, and “athletes”. We focused on studies examining postural control recovery status with performance-based laboratory and clinical tests in individuals with SRC. Only articles with human participants published in the English language were included. No limitations on study design and year of publication were used.

5.2.2 Generating a pool of potential clinical postural control tests

A stepwise process was used to generate a preliminary pool of clinical postural control tests. After summarizing the tests used to evaluate postural control following SRC in the literature, we consulted a physical therapist (CI) with experience in the management of SRC to determine whether a comprehensive list of all tests that are commonly used by clinicians were included. Additional tests were added to the list if needed. We then reviewed the list of tests to identify whether the included tests assessed postural control while performing specialized movements involved in sport. If none of the included tests evaluated postural control while performing specialized movements involved in sport, we developed a new sport-related postural control test. Initially, we informally reviewed the current scientific literature to identify specialized movements that are commonly involved in sport. Articles were assembled through PubMed and Google

Scholar searches using the combinations of the following terms: “performance”, “physical characteristics”, “physical quality”, and “athletes”. Only articles with athletes published in the English language were included. We, next, organized the identified specialized movements into a testing protocol that challenged systems of postural control that may be affected following SRC. Potentially affected systems of postural control were identified from the “defining the measurement construct” step illustrated above. Disagreement in the selected specialized movements was resolved by the investigative team’s consensus.

5.2.3 Expert review of clinical postural control tests

A group of content experts (i.e., neurologist, a neuropsychologist, and two physical therapists) reviewed the preliminary pool of clinical tests. Each of the content experts had more than five years of experience in SRC management and was involved in research studies related to the assessment and management of SRC. The content experts reviewed the comprehensiveness (i.e., whether all clinical tests that clinicians commonly use for postural control assessment in SRC were included), and relevance (i.e., are the clinical tests relevant for examining postural control recovery status following SRC?) of the preliminary pool of clinical tests.[12] The lead investigator used ‘one-to-one interviews’ to obtain and document (in writing) the experts’ feedback. Content experts’ feedback was reviewed to inform changes to the preliminary pool of clinical tests. Disagreement in the preliminary pool of clinical tests was resolved by the investigative team’s consensus.

5.2.4 Pilot testing

We assessed the feasibility of the preliminary version of the sport-related postural control test. Specifically, we examined the clarity of instructions (i.e., whether the provided instructions were understood by participants and appropriately worded), workflow (i.e., any difficulties while performing the tasks), duration, safety (i.e., were there any unexpected adverse events such as falling, injuries, or increased SRC related symptoms?). Feedback from evaluators and participants was reviewed to inform changes to the preliminary version of sport-related postural control test. Next, we evaluated the relative and absolute reliability (intra and inter) of the components of the final version of the sport-related postural control test in a sample of uninjured active youth and young adults.

5.2.4.1 Participants

We recruited a volunteer sample of uninjured active (Cincinnati Sports Activity Scale level one or two) [13] youth and young adults (13 – 24 years of age) from a university-based sports medicine clinic, private physiotherapy clinics, or local sports organizations. Participants were recruited through advertisements, social media, and word of mouth. Exclusion criteria included: (1) Cincinnati Sport Activity Scale levels three or four; (2) lower extremity injury that caused absence from recreational/sport activities greater than one week within the last three months; (3) sinus or inner ear infection over the week prior to testing; (4) uncorrectable vision dysfunction at time of testing; (5) history of cognitive deficits; (6) history of attention deficit hyperactivity disorder; or (7) non-English speaking.

We planned to recruit 10 participants to assess the feasibility of the the preliminary version of the sport-related postural control test. The sample size required for reliability testing was 18

participants calculated based on guidelines provided by Walter et al [14] when $\beta = 0.20$, $\alpha = 0.05$, and a desired intra-class correlation coefficient (ICC range) of 0.75 (minimally acceptable ICC) to 0.90 (the optimal ICC value for measures used in clinical practice).[15]

5.2.4.2 Procedures

Data were collected at a private physiotherapy clinic. On the day of testing, participants reported demographic (i.e., sex, age, and the primary played sport) and medical history (i.e., history of previous concussions and current medications) information using a questionnaire adapted from the Sports Concussion Assessment Tool–5th edition.[16] To assess the feasibility of the sport-related postural control test, three investigators (TM, JLW, DPG) and a physical therapist (CI) examined participants' postural control during the test using its preliminary version in one session. Using a cognitive interviewing method (i.e., think-aloud) the lead investigator (TM) documented (in writing) evaluators' and participants' feedback,[17] the time required to complete the test and number of adverse effects (i.e., falls, injury, or increased symptoms). The investigative team met to discuss feedback from the evaluators and participants, and modified the preliminary version of the sport-related postural control test. The absolute and relative reliability of the final test's components was then assessed. Two raters (TM and CI) assessed participants as they completed three trials of the test's components twice within one day. The two raters independently rated and recorded individual participant's performance on the test's components during testing session one. One rater (TM) repeated rating the performance of all participants on the test's components later on the same day (session two). Each of the two raters had more than five years of experience in postural control assessment following SRC, and met before data collection to review and discuss the test instructions and scoring procedures. During the two testing sessions, the Turn and Go

component was performed first followed by the Lateral Shuffle component. Participants were given approximately a one-minute rest between trials to minimize fatigue. The raters followed a specific script for the sport-related postural control test to standardize test instruction between raters and testing sessions.

5.2.4.3 Analysis

Descriptive statistics [mean (standard deviation), median (range) or proportion as appropriate] were used to summarize all outcomes. For continuous outcomes, ICC_{2,1} with 95% confidence interval (CI), based on trial one and the average of three trials, were calculated to estimate relative intra-rater and inter-rater reliability.[18] Measurement precision [standard error of measurement (SEM = pooled Standard Deviation x $\sqrt{1 - ICC}$)],[15] and minimal detectable changes at the 95% confidence level (MDC₉₅ = 1.96 x SEM x $\sqrt{2}$), based on trial one and the average of three trials, were calculated to estimate absolute intra-rater and inter-rater reliability.[19] Bland-Altman plots (i.e., mean difference and 95% limits of agreement) were used to assess for systematic bias between the first and third trial at session one, and between sessions (the average of three trials at session one minus the average of three trials at session two) of the sport-related postural control test's components using data from rater one (TM).[20] For dichotomous outcomes, Cohen's Kappa (κ) coefficient with 95% CI were calculated for three trials to estimate intra-rater and inter-rater agreement.[21] All analyses were performed using IBM SPSS 25 for Windows (Armonk, New York).

5.3 RESULTS

5.3.1 Defining the measurement construct

The literature review revealed that postural control impairment stemming from SRC is a multidimensional construct that involves deficits in numerous systems underlying postural control including movement strategies (reaction time), control of dynamics (gait), sensory strategies (sensory integration), and cognitive contributions (dual-task).[22] Further, that these impairments are task dependent. For instance, athletes with a diagnosis of SRC demonstrate greater postural control impairment while performing dual-task assessments (i.e., controlling posture with a secondary cognitive task) as compared to single-tasks (i.e., controlling posture without a secondary cognitive task).[22] Accordingly, it has been hypothesized that athletes with a diagnosis of SRC may demonstrate postural control impairments while performing sport-related movements.[23]

5.3.2 Generating a pool of potential clinical postural control tests

The literature search identified several clinical tests that are commonly used to examine postural control recovery status following SRC. These include the Balance Error Scoring System,[24] Clinical Test of Sensory Interaction in Balance,[25] Clinical Reaction Time,[7] Dynamic Gait Index,[26] Functional Gait Assessment,[26] modified-Balance Error Scoring System,[16] Romberg Test,[25] Standing Balance Test,[26] Stroop Test,[27] Tandem Gait Test,[16] and Walking While Talking Test.[26] The content expert confirmed these findings. As our search did not identify tests for examining postural control recovery status during sport-related movements, we focused on designing a preliminary version of a new sport-related postural control test.

Based on the literature review, we concluded that a rapid whole-body movement with change of velocity and/or direction is commonly involved in sport.[28-31] Based on this conclusion and other findings from the “defining the measurement construct” step, we designed the preliminary version

of the sport-related postural control test to involve: (1) running with frequent change of direction, (2) an external stimuli to challenge reaction time, (3) a timed running in a narrow base-of-support to challenge velocity and medial-lateral center-of-mass displacement, (4) repeated turns to challenge the vestibular system and head-eye movement, and (5) a divided-attention task to increase the complexity of the test, which may assist in detecting postural control impairments.[32] The figure 1 in appendix 4 presents a full description of the preliminary version of the sport related postural control test, which consisted of one component (referred to hereafter ‘Turn and Go component’).

5.3.3 Expert review of clinical postural control tests

The content experts supported findings from the literature review and confirmed the comprehensiveness and relevance of the preliminary pool of clinical postural control tests including the newly developed sport-related postural control test. One of the reviewers (neurologist) suggested adding a patient-reported outcome measure that captures participants’ symptoms after performing the sport-related postural control test to make it more comprehensive. Based on this, the 21-item adolescent (ages 13-18 years) version of the Post-Concussion Symptom Inventory was added to the protocol.[33] The Post-Concussion Symptom Inventory has been validated for use with adolescent following SRC. It has moderate to strong test–retest reliability (ICCs = 0.65–0.89).[33] In the current study, participants completed the Post-Concussion Symptom Inventory before and after completing the sport-related postural control test.

5.3.4 Pilot testing

5.3.4.1 Participants

Of 45 individuals who expressed interest in participating in the study, four did not meet the inclusion criteria (history of concussion within the year prior to testing), three declined to participate (time constraints), and nine did not respond to communications, leaving a sample of 29 participants. One participant withdrew after consenting, but prior to testing for undisclosed personal reasons. Participant characteristics are summarized in Table 1. While we initially planned to evaluate the feasibility of the preliminary version of the sport-related postural control test after the initial 10 participants were enrolled, we decided to stop recruitment after the initial five participants as we reached a saturation point (i.e., no new information was being provided by the evaluators or participants). For reliability testing, 23 participants completed two sessions of testing. While 22 participants (95%) attended the second session within 4 hours after testing session one, one participant attended the second session within 22 hours after session one. Nine of the participants (39%) had suffered a concussion greater than one year prior to testing. One participant (4.3%) reported current use of antibiotics for acne.

5.3.4.2 Feasibility

Table 1 presented in appendix 4 shows comments made by the evaluators and participants involved in testing the feasibility of the preliminary version of the sport-related postural control test along with the revisions that were made. The median total time a participant required to complete the preliminary sport-related postural control test was 16.9 seconds (ranging from 13 to 22 seconds). No adverse effects were documented during feasibility testing. Figure 1 shows the final version of the sport-related postural control test, which consisted of one component (i.e., the ‘Turn and Go’

component. The Turn and Go component involves forward running and turning. One of the investigative team (JW) suggested adding another component to the sport-related postural control test that involves side-shuffling and backward running as these movements are typically performed during sport-participation. Based on this, another component of the sport-related postural control test (referred to hereafter ‘Lateral Shuffle component’) was added to the test. Both the Turn and Go and Lateral Shuffle components are scored based on the amount of time (seconds) participants require to complete the component and a subjective (pass/fail) assessment of participants’ ability to perform the component. Appendix 5 shows the Turn and Go and Lateral Shuffle components with scoring, examiner, and patient instructions.

5.3.4.3 Reliability

Summary statistics for participants’ performance on the Turn and Go and Lateral Shuffle components are summarized by session and rater in Table 2. Table 3 summarizes reliability estimates for the time assessment of the components calculated using trial one and an average of all three trials. While all ICCs estimates calculated based on the average of three trials were > 0.75 , only one was > 0.75 when calculated based on trial one. Overall, administering the Turn and Go and Lateral Shuffle components three times and averaging the three trials provided lower SEMs and MDCs. Table 4 presents intra- and inter-rater Cohen’s κ estimates for the pass/fail assessment of the Turn and Go and Lateral Shuffle components.

Table 5 summarizes the mean difference (SD) and 95% limits of agreement associated with Bland-Altman plots for between trials and between sessions of the Turn and Go and Lateral Shuffle

components. There was a positive shift in the difference scores between trials and between sessions related to both components (see Figure 2).

On further analysis, we observed that the average of three trials provided higher intra- and inter-rater reliability (ICC ranged from 0.85 to 0.97) estimates compared to trial three (ICC ranged from 0.84 to 0.91) of the Turn and Go and Lateral Shuffle components. Further, the positive shift seen in the Bland-Altman plots for both components persisted between trials one and two (mean difference ranged from 0.17 to 0.51), as well as trials two and three (mean difference ranged from 0.37 to 0.44). The positive shift seen remained after stratifying the analysis by age and sex.

5.4 DISCUSSION

We have proposed a sport-related postural control test that is appropriate for SRC, and evaluated its reliability (inter and intra) in a sample of uninjured active youth and young adults. Our analysis suggests that averaging observations across three trials produced higher relative and absolute intra- (between-session) and inter- (within session) rater reliability for the time assessment of the components (see Table 3). The reliability and precision of the pass/fail assessment of the components, however, are low (see Table 4). Overall, participants' performance improved from trial one to trial three and session one to session two (see Figure 2), which suggests the possibility of a learning effect.

To the best of our knowledge, the High-Level Mobility Assessment Tool is the only feasible (i.e., available without associated cost) scale used in SRC that extends postural control assessment beyond standing and walking tasks.[34] The tool involves a running item that requires an injured individual to cover a distance of 20 meters with the middle 10 meters being timed. A tested

individual fails the running item if unable to keep a consistent flight phase during testing.[34] Although the High-Level Mobility Assessment Tool demonstrated comparable test-retest reliability (ICC = 0.88) in healthy adults (age ranged from 18 to 25 years),[34] it does not encapsulate the full range of sport-related movements (i.e., forward running, turning, backward running, and side-shuffling) that should be examined prior to making a RTP decision following SRC.

Studies involving instrumented assessments (e.g., instrumented motion capture) of postural control under complex tasks (e.g., walking with secondary cognitive tasks) have identified deficits well beyond clinical postural control recovery (i.e., 3-5 days for Balance Error Scoring System to return to baseline) after SRC. This observation further supports the need for a more challenging measure of post-SRC postural control. Unfortunately, the instrumented measures used in these studies are not clinically feasible given the time, cost and need for specialized equipment and technicians. Our findings suggest that the use of the Turn and Go and Lateral Shuffle components may help to fill the gap between the laboratory and clinical assessments of postural control following SRC, given the minimal cost, training, and time required to perform the components.

The proposed Turn and Go and Lateral Shuffle components demonstrated reliability in uninjured youth and young athletes. Our preliminary findings suggest that interpreting the mean score from three administrations of the components produces the most reliable time scores. Further, there is a 95% probability that a change of 1.8 seconds for the Turn and Go component and 1 second for the Lateral Shuffle component is due to a change in postural stability rather than variability in trial scores by a single rater. There is a 95% probability that a change of 0.9 seconds for the Turn and Go component and 2 second for the Lateral Shuffle component is due to a change in postural

stability rather than variability in scores between raters. Finally, multiple components exposures may lead to improved postural control due to a learning effect, which can be eliminated by implementing a practice session before final testing.

5.4.1 Strengths and Limitations

The main strengths of the current study are that the content of the Turn and Go and Lateral Shuffle components was established based on a review of scientific literature and consultation with experts, and their reliability was evaluated using relative reliability ($ICC \geq 0.75$) and absolute reliability (SEM and MDC) methodologies. However, this study has limitations. Specifically, the order of test's components administration was not random, which added standardization but may have contributed to the observed learning effect. Further, the generalizability of our findings to injured youth and young adults is limited as we recruited only uninjured participants. As the majority (65.2%) of the recruited sample played hockey, ringette, or soccer, the generalizability of our findings to different sports may be limited. Similarly, the generalizability of our findings to females may be limited due to the fact that the majority (61%) of the recruited sample were males.

The current study is a first step toward establishing a line of research that evaluates the clinometric properties of a sport-related postural control testing protocol for identifying postural control deficits in adolescents and young adults with SRC. Future studies examining the reliability, validity, and responsiveness of the Turn and Go and Lateral Shuffle components in injured youth and young adult athletes are required before widespread use in clinical settings.

5.5 CONCLUSION

The proposed Turn and Go and Lateral Shuffle components of a sport-related postural control test demonstrated feasibility and reliability in uninjured active youth and young adults. Further assessment of the clinometric properties of the components in injured active youth and young adults is required before widespread use in clinical settings.

5.6 REFERENCES

- 1.Horak FB. Postural orientation and equilibrium: what do we need to know about neural control of balance to prevent falls? *Age Ageing*. 2006;35 Suppl 2(SUPPL.2):ii7-ii11.
- 2.Horak FB, Wrisley DM, Frank J. The Balance Evaluation Systems Test (BESTest) to differentiate balance deficits. *Phys Ther*. 2009;89(5):484-98.
- 3.Sibley KM, Beauchamp MK, Van Ooteghem K, Straus SE, Jaglal SB. Using the systems framework for postural control to analyze the components of balance evaluated in standardized balance measures: a scoping review. *Arch Phys Med Rehabil*. 2015;96(1):122-32 e29.
- 4.Park J-H, Kang Y-J, Horak FB. What is wrong with balance in Parkinson's disease? *Mov Disord*. 2015;8(3):109.
- 5.McCrory P, Meeuwisse W, Dvorak J, Aubry M, Bailes J, Broglio S, et al. Consensus statement on concussion in sport-the 5(th) International Conference on Concussion in Sport held in Berlin, October 2016. *Br J Sports Med*. 2017;51(11):838-47.
- 6.Woods DL, Wyma JM, Yund EW, Herron TJ, Reed B. Factors influencing the latency of simple reaction time. *Front Hum Neurosci*. 2015;9:131.
- 7.Eckner JT, Richardson JK, Kim H, Joshi MS, Oh YK, Ashton-Miller JA. Reliability and criterion validity of a novel clinical test of simple and complex reaction time in athletes. *Percept Mot Skills*. 2015;120(3):841-59.

8. Johnston W, Coughlan GF, Caulfield B. Challenging concussed athletes: the future of balance assessment in concussion. *QJM*. 2016;110(12):779-83.
9. Howell DR, Lynall RC, Buckley TA, Herman DC. Neuromuscular control deficits and the risk of subsequent injury after a concussion: a scoping Review. *Sports Med*. 2018;48(5):1097-115.
10. Cross M, Kemp S, Smith A, Trewartha G, Stokes K. Professional Rugby Union players have a 60% greater risk of time loss injury after concussion: a 2-season prospective study of clinical outcomes. *Br J Sports Med*. 2016;50(15):926-31.
11. Johnson RL, Morgan GB. Survey scales: a guide to development, analysis, and reporting. NY: Guilford Publications; 2016.
12. Terwee CB, Prinsen CAC, Chiarotto A, Westerman MJ, Patrick DL, Alonso J, et al. COSMIN methodology for evaluating the content validity of patient-reported outcome measures: a Delphi study. *Qual Life Res*. 2018;27(5):1159-70.
13. Smith FW, Rosenlund EA, Aune AK, MacLean JA, Hillis SW. Subjective functional assessments and the return to competitive sport after anterior cruciate ligament reconstruction. *Br J Sports Med*. 2004;38(3):279-84.
14. Walter SD, Eliasziw M, Donner A. Sample size and optimal designs for reliability studies. *Stat Med*. 1998;17(1):101-10.
15. Portney LG, Watkins MP. Foundations of clinical research: applications to practice. 2nd ed. NJ: Prentice Hall Upper Saddle River; 2000.

16. Echemendia RJ, Meeuwisse W, McCrory P, Davis GA, Putukian M, Leddy J, et al. The Sport Concussion Assessment Tool 5th Edition (SCAT5): background and rationale. *Br J Sports Med.* 2017;51(11):848-50.
17. Redline C, Smiley R, Lee M, DeMaio T, editors. Beyond concurrent interviews: an evaluation of cognitive interviewing techniques for self-administered questionnaires. Proceedings of the Section on Survey Research Methods, American Statistical Association; 1998: Citeseer.
18. Koo TK, Li MY. A guideline of selecting and reporting intraclass correlation coefficients for reliability research. *J Chiropr Med.* 2016;15(2):155-63.
19. Roebroeck ME, Harlaar J, Lankhorst GJ. The application of generalizability theory to reliability assessment: an illustration using isometric force measurements. *Phys Ther.* 1993;73(6):386-95.
20. Bland JM, Altman D. Statistical methods for assessing agreement between two methods of clinical measurement. *The lancet.* 1986;327(8476):307-10.
21. McHugh ML. Interrater reliability: the kappa statistic. *Biochem Med (Zagreb).* 2012;22(3):276-82.
22. Register-Mihalik JK, Littleton AC, Guskiewicz KM. Are divided attention tasks useful in the assessment and management of sport-related concussion? *Neuropsychol Rev.* 2013;23(4):300-13.
23. Manaseer TS GD, Mrazik M, Schneider K, Whittaker JL. Re-conceptualizing postural control assessment in sport-related concussion: Transitioning from the Reflex/Hierarchical Model to the Systems Model. *Physiother Theory Pract.* 2019;Aug(1):1-2.

24. Bell DR, Guskiewicz KM, Clark MA, Padua DA. Systematic review of the Balance Error Scoring System. *Sports Health*. 2011;3(3):287-95.
25. Murray N, Salvatore A, Powell D, Reed-Jones R. Reliability and validity evidence of multiple balance assessments in athletes with a concussion. *J Athl Train*. 2014;49(4):540-9.
26. Grinnon ST, Miller K, Marler JR, Lu Y, Stout A, Odenkirchen J, et al. National institute of neurological disorders and stroke common data element project—approach and methods. *Clin Trials*. 2012;9(3):322-9.
27. Manaseer TS, Gross DP, Dennett L, Schneider K, Whittaker JL. Gait deviations associated with concussion: A Systematic Review [published online ahead of print, 2017 Nov 21]. *Clin J Sport Med*. 2017;10.1097/JSM.0000000000000537. doi:10.1097/JSM.0000000000000537.
28. Stewart PF, Turner AN, Miller SC. Reliability, factorial validity, and interrelationships of five commonly used change of direction speed tests. *Scand J Med Sci Sports*. 2014;24(3):500-6.
29. Chiwaridzo M, Ferguson GD, Smits-Engelsman BC. A systematic review protocol investigating tests for physical or physiological qualities and game-specific skills commonly used in rugby and related sports and their psychometric properties. *Syst Rev*. 2016;5(1):122.
30. Thomas TDSC, Comfort P, Jones PA. Comparison of change of direction speed performance and asymmetries between team-sport athletes: application of change of direction deficit. *Sports*. 2018;6(4):174.

31. Nimpfius S, Callaghan SJ, Bezodis NE, Lockie RG. Change of direction and agility tests: Challenging our current measures of performance. *Strength Cond J*. 2018;40(1):26-38.
32. Howell DR, Osternig LR, Chou LS. Single-task and dual-task tandem gait test performance after concussion. *J Sci Med Sport*. 2017;20(7):622-6.
33. Sady MD, Vaughan CG, Gioia GA. Psychometric characteristics of the postconcussion symptom inventory in children and adolescents. *Arch Clin Neuropsychol*. 2014;29(4):348-63.
34. Williams G, Rosie J, Denisenko S, Taylor D. Normative values for the high-level mobility assessment tool (HiMAT). *Int J Rehabil Res*. 2009;16(7):370-4.

5.7 TABLES

Table 5-1: Participant Characteristics

Table 1. Participant Characteristics (n=23)

Characteristic	Group	
	Feasibility Sample (n=5)	Reliability Sample (n=23)
Sex (female %)	2 (40%)	9 (39.1%)
Age (years), median (min-max)	14 (13-19)	17 (13–24)
Main played sport (%)	Hockey (60%)	Hockey (22%)
History of previous concussion (%)	0 (0%)	9 (39.1%)
Current medication (yes %)	0 (0%)	1 (4.3%)

Table 5-2: Summary Statistics for the Sport-Related Postural Control Test by Variation, Session, and Rater

Table 2: Summary Statistics for the Sport-Related Postural Control Test by Variation, Session, and Rater (n=23)

Test	Session 1, Rater 1				Session 1, Rater 2				Session 2, Rater 1			
	T1	T2	T3	Average	T1	T2	T3	Average	T1	T2	T3	Average
Turn and Go (seconds)	17 (7)	17 (7)	17 (7)	17 (7)	17 (8)	17 (9)	16 (9)	17 (8)	16 (6)	16 (6)	16 (9)	16 (7)
Turn and Go (% pass)	60	87	78	75	73	91	78	80	52	87	87	75
Lateral Shuffle (seconds)	17 (12)	17 (10)	16 (8)	17 (9)	17 (23)	16 (12)	16 (8)	17 (10)	17 (11)	17 (11)	16 (7)	17 (10)
Lateral Shuffle (% pass)	69	73	73	71	56	69	73	66	65	60	69	65

Note. Values are presented as median (range) or percentage. Lateral Shuffle: a sport-related postural control test that involves side-shuffling and backward running, T: trial. Turn and Go: a sport-related postural control test that involves forward running and turning

Table 5-3: Intra- and Inter-Rater ICC, SEM, and MDC for Time Component of the Sport-Related Postural Control Test

Table 3: Intra- and Inter-Rater ICC, SEM, and MDC for Time Component of the Sport-Related Postural Control Test (n=23)

Estimates Based on Trial 1						
	Intra-rater			Inter-rater		
	ICC (2,1) (95% CI)	SEM	MDC	ICC (2,1) (95% CI)	SEM	MDC
Turn and Go (seconds)	0.38 (0,0.67)	1.4	3.8	0.70 (0.41,0.86)	1.0	2.8
Lateral Shuffle (seconds)	0.87 (0.68,0.94)	0.9	2.6	0.42 (0.02,0.70)	2.7	7.4
Estimates Based on the Average of Three Trials						
Turn and Go (seconds)	0.85 (0.43,0.94)	0.7	1.8	0.97 (0.93,0.98)	0.3	0.9
Lateral Shuffle (seconds)	0.94 (0.87,0.97)	0.6	1.0	0.92 (0.82,0.96)	0.7	2.0

Note. CI: confidence interval, ICC: intra-class correlation coefficient, Lateral Shuffle: a sport-related postural control test that involves side-shuffling and backward running, MDC: minimal detectable change, SEM: standard error of measurement, Turn and Go: a sport-related postural control test that involves forward running and turning

Table 5-4: Kappa Statistics for the Pass/Fail Component of the Sport-Related Postural Control Test

Table 4: Kappa Statistics for the Pass/Fail Component of the Sport-Related Postural Control Test (n=23)

Test Version	Intra-rater			Inter-rater		
	Trial 1	Trial 2	Trial 3	Trial 1	Trial 2	Trial 3
	κ (95% CI)	κ (95% CI)	κ (95% CI)	κ (95% CI)	κ (95% CI)	κ (95% CI)
Turn and Go	0.47 * (0.05,0.88)	0.23 (0,0.98)	0.40 * (0,1)	0.71 * (0.05,1)	0.77 * (0.24,1)	0.48 * (0.08,1)
Lateral Shuffle	0.90 * (0.43,1)	0.51 * (0.04,0.96)	0.46 * (0,0.95)	0.72 * (0.82,1)	0.46 * (0,0.95)	0.54 * (0.03,1)

Note. * $p < 0.05$. CI: confidence interval, Lateral Shuffle: a sport-related postural control test that involves side-shuffling and backward running, T: trial. Turn and Go: a sport-related postural control test that involves forward running and turning

Table 5-5: Summary Data Associated with Bland-Altman Plots for the Components of the Sport-Related Postural Control Test

Table 5: Summary Data Associated with Bland-Altman Plots

Test Version	Mean Difference (SD)	95% LOA	Mean Difference (SD)	95% LOA
	T1 to T3	T1 to T3	S1 to S2	S1 to S2
Turn and Go (second)	0.5 (1.6)	-2.6 to 3.7	0.8 (1.0)	-1.1 to 2.8
Lateral Shuffle (second)	0.9 (1.3)	-1.7 to 3.6	0.3 (1.0)	-1.7 to 2.4

Note. Lateral Shuffle: a sport-related postural control test involves side-shuffling and backward running, LOA: limits of agreement, S: session, SD: standard deviation, T: trial, Turn and Go: a sport-related postural control test involves forward running and turning.

5.8 FIGURES

Figure 5-1: The Design of the Final Version of a Sport-Related Postural Control Test for Postural Control Assessment following Sport-Related Concussion

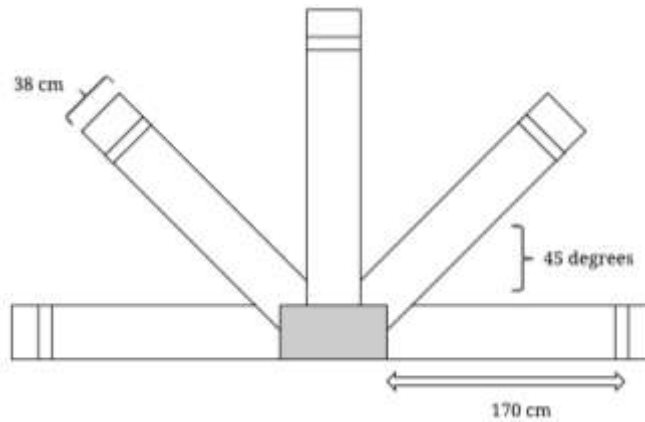

Figure 1. The design of the final version of a sport-related postural control test for postural control assessment following sport-related concussion. The gray area shows the starting point. Five paths are arranged on the floor in a semicircle at different angles (0, 45, and 90 degrees) from the midline. The length and width of each path are standardized at 170 and 38 centimeter, respectively. A tested individual is asked to run from the starting point, pass beyond the end points (tape-strips that are shown as double lines in the figure) at the end of each path with both feet, turn around, and run back to the starting point. The order of endpoints are randomly assigned by the examiner (each endpoint has a different colour of tape). Total time an injured athlete needs to complete the task (moving through five paths) and ability to stay within the assigned paths (pass/fail) are record. A tested individual fails if steps off the assigned path.

Figure 5-2: Bland-Altman Plots of the Difference in Sport-Related Postural Control Test between Trials and Sessions against the Mean Difference

Figure 2. Bland-Altman plots of the difference in sport-related postural control test between (A and B) trials one and three in session one, and (C and D) sessions one and two against the mean difference. The solid horizontal lines represent the mean difference. The dashed horizontal lines represent the 95% upper and lower limits of agreement.

a. Turn and Go (seconds)

b. Lateral Shuffle (seconds)

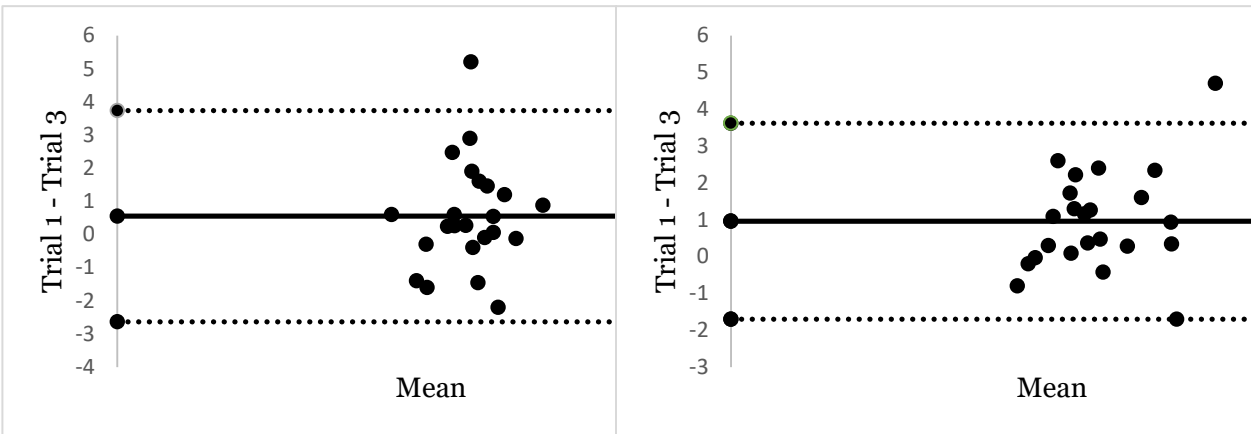

c. Turn and Go (seconds)

d. Lateral Shuffle (seconds)

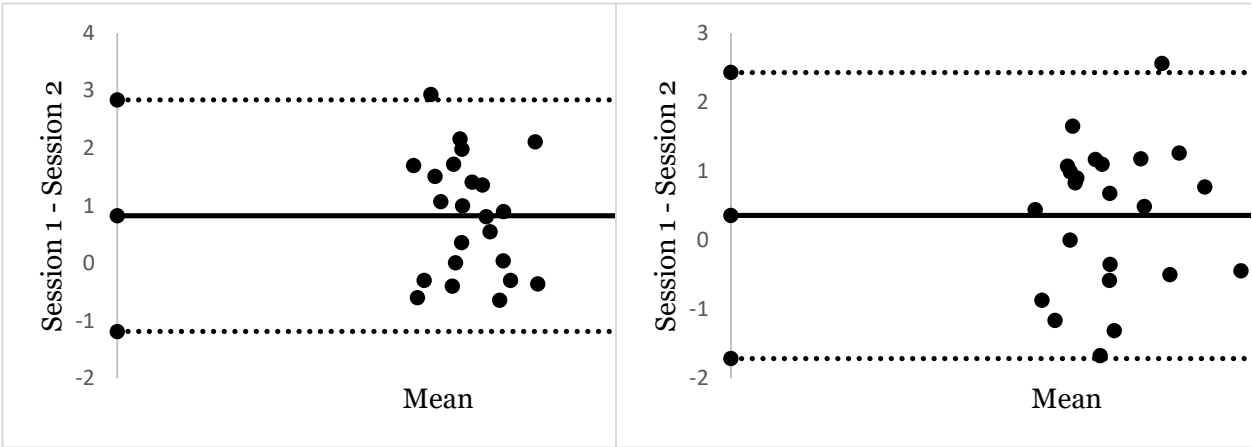

CHAPTER 6– THE FUNCTIONAL ASSESSMENT OF BALANCE IN CONCUSSION (FAB-C) BATTERY

ABSTRACT

Background: Currently, there is no clinical tool that assesses multiple components of postural control potentially impacted by sport-related concussion (SRC).

Objective: To examine the feasibility and preliminary construct validity of a novel SRC postural control assessment battery; the Functional Assessment of Balance in Concussion (FAB-C).

Methods: Tests for inclusion in a FAB-C battery were identified through a search of the evidence, taking into consideration tests' purposes and clinimetric properties. The feasibility and construct validity of the battery was assessed with a convenience sample of active youth (13–17 years) and young adults (18–24 years) with and without a SRC. Feasibility outcomes included battery completion, correlation patterns between tests included in the battery, number of adverse events, time to administer and cost of the battery. Construct validity was assessed by describing differences [mean (standard deviation), median (range) or proportion] in outcomes between uninjured participants and participants with SRC.

Results: Seven tests that examine different components of postural control under single-task, dual-task, and sport-specific testing paradigms were included in the FAB-C battery. All 40 uninjured participants [21 youth, 12 female; median age 17 years] completed the entire FAB-C assessment compared to 86% of seven participants with SRC [six youth, 1 female; median age 17]. Limited correlations ($r < 0.7$) between tests included in the battery were observed. No participants

demonstrated adverse effects. The cost of the battery was low (~\$100 CAD) and the median administration time of the battery was 49 minutes (range from 44 to 60). A greater percentage of uninjured participants (52% to 82%) passed individual battery component tests compared to participants with SRC (17% to 66%).

Conclusion: Although promising, the newly developed FAB-C battery requires further evaluation including reliability and validity before widespread clinical use. The FAB-C battery provides clinicians with a comprehensive clinical tool that examines multiple components of postural control that can be affected following SRC.

6.1 INTRODUCTION

Adequate postural control is a prerequisite for safe sports participation.[1] Postural control is a complex task requiring continuous interactions between biomechanical, sensory, motor and cognitive contributions. The components of postural control have been conceptualized to include: (1) movement strategies, (2) control of dynamics, (3) sensory strategies, (4) cognitive contributions, (5) orientation in space, and (6) biomechanical elements (see Table 3 - 1). Postural impairments may result from deficits in one or more of these components.[2, 3]

Sport-related concussion (SRC) is a traumatic brain injury induced by a biomechanical force.[4] Impaired postural control is a common sign of SRC, presents in up to 80% of athletes who suffer a SRC.[5] Accordingly, postural control assessment is critical for SRC diagnosis and return-to-sport (RTS) decisions. The most commonly used clinical (i.e., non-instrumented) postural control assessment tools for SRC, Balance Error Scoring System (BESS) and modified Balance Error Scoring System (m-BESS) are relatively inexpensive and easy to administer.[4, 6] These tools are based on the premise that SRC postural control impairments are the result of sensory deficits alone, which have been shown to resolve within three to five days following injury.[7] In fact, more sophisticated laboratory tests of postural control have demonstrated that SRC postural control impairments are also associated with motor and cognitive deficits that may persist beyond five days.[8] Given that typical standing postural control tests are unable to challenge cognitive and motor resources, additional tests are required to evaluate the potential postural control consequences of SRC.[9-11]

Given the inadequacies of common clinical tests and limited feasibility of using laboratory measures in clinical settings,[12] it is plausible that an athlete may be cleared for RTS despite ongoing postural control impairments, which may increase their risk of future injury.[13] In response to this problem, there is a need for comprehensive clinical methods to assess postural control following SRC.[4, 10, 11] The primary objectives of the current study were to describe the development and refinement of a comprehensive battery that assesses the sensory, motor, and cognitive components of postural control that may be impacted by a SRC, the Functional Assessment of Balance in Concussion (FAB-C) battery, and to examine its feasibility in a sample of active, uninjured youth and young adults. A secondary objective was to examine differences in the performance of FAB-C battery components between uninjured youth and young adults and those who had recently RTS following SRC.

6.2 METHODS

6.2.1 Development of the FAB-C battery

The development of the FAB-C battery was guided by a recently proposed model of postural control assessment following SRC (see Figure 3-2).[14] This model proposes that a comprehensive assessment of postural control following a SRC should include clinical tests that challenge sensory strategies, control of dynamics, movement strategies, and cognitive contributions components of postural control under single-task, dual-task, and sport-specific testing paradigms.

To identify tests that challenge sensory strategies, control of dynamics, movement strategies, and cognitive contributions components of postural control under single-task, dual-task, and sport-specific testing paradigms for possible inclusion in the FAB-C battery, we initially consulted the

scientific evidence-base to identify existing clinical tests with established clinometric properties. This list was reduced by comparing existing clinical tests' purposes (i.e., the evaluated component of postural control) and clinometric properties. Findings from the aforementioned steps were used to develop an unrefined version of the FAB-C battery, which was further examined for feasibility and preliminary construct validity. The final version of the FAB-C battery created is a first step toward establishing a line of research that evaluates the clinometric properties and clinical utility of a comprehensive battery that assesses the sensory, motor, and cognitive components of postural control that may be impacted by a SRC.

6.2.2 *Participants*

We initially planned to recruit a convenience sample of active (Cincinnati Sports Activity Scale level one or two),[15] youth athletes (13–17 years of age) who either recently RTS following SRC or without a concussion from private physiotherapy clinics, sport organizations, through advertisements, social media, and word of mouth between December 2017 – May 2019. To enhance the generalizability of our findings, we expanded the eligible range of age to include young adult athletes (18 – 24 of age) given the high incidence of SRC among youth and young adult athletes.[16, 17] Participants with SRC must have been diagnosed with SRC as per the International Consensus on Concussion in Sport [4] have returned to sport (i.e., unrestricted return to practice, game, or competition) within the 60 days prior to testing. Uninjured participants were individuals who had not been diagnosed within the past year. Participants were excluded if they were not active in recreational or competitive sport; reported a history of lower extremity injury that caused absence from recreational/sport activities greater than one week within the last three months, inner ear or sinus infection over the week prior to testing, uncorrectable (i.e., neither with

vision glasses nor contacts) vision dysfunction at time of testing, history of cognitive deficits such as concentration abnormalities, history of attention deficit hyperactivity disorder; or were non-English speakers. Ethics approval was acquired from the the University of Alberta Health Research Ethics Board (No: Pro00077091, Date: December 19, 2017) prior to testing. Participants and/or their parents provided written consent and/or assent prior to data collection as appropriate.

6.2.3 Procedures

Data were collected at either a university lab or a private physiotherapy clinic. On the day of testing, participants completed study questionnaires that gathered demographic and medical history information. Participants were familiarized with the FAB-C testing protocol and performed a warm-up (i.e., 1 minute of sidestepping, 1 minute of jogging backward, and 3 minutes of jogging forward) prior to data collection.[18] The lead investigator, who is a physical therapist with seven years of experience in SRC management, scored the performance of participants' as they completed three trials of the FAB-C battery. Short rest breaks (i.e., 1 – 2 minutes) were provided between trials as needed. In the current study, participants performed the FAB-C testing protocol with their shoes on to mimic a real-world on-field application of postural control testing following an SRC. The lead investigator also recorded all feasibility outcomes of interest.

6.2.4 Outcomes

A questionnaire adapted from the Sports Concussion Assessment Tool–5th edition (SCAT5)[19] was used to collect information on participants' sex, age, primary sport and medical history (i.e., history of previous concussions, current medications, number of days since injury, number of days since RTS, the health care provider who made a diagnosis of SRC, and the health care provider

who made a RTS decision). Feasibility outcomes included the number of participants who completed the entire assessment, correlation patterns between clinical tests included in the FAB-C battery for battery refinement, potential for adverse events (i.e., falls, near-miss falls, injury, or increased symptoms), and burden (i.e., the cost of required equipment and time required to complete the assessment). Finally, FAB-C outcomes included the individual scores from the tests that made up the battery. The specific outcome and clinimetric properties of these tests are reported below.

6.2.5 Analysis

Data from participants who completed the entire testing battery were included in the analysis. Descriptive statistics [mean (standard deviation), median (range) or proportion as appropriate] were used to summarize all FAB-C clinical test outcomes. A multitrait Spearman's correlation coefficient matrix was used to examine correlation patterns between clinical tests included in the FAB-C battery to identify whether they assessed similar or unique components of postural control.[20] The non-parametric Spearman's correlation was used given the small sample size in this study. If the Spearman's correlation between two clinical tests was 0.7 or higher, it was assumed that one of them could be replaced with another clinical test based on tests' purposes and clinimetric properties.[21] An α level of 0.001 was chosen to judge significance while accounting for the multiple comparisons performed. The percentage of participants who completed the entire FAB-C battery, the percentage of participants who demonstrated adverse events during and/or after testing, cost (in Canadian dollars) of equipment required, and average time (in minutes) required to administer the FAB-C battery were calculated. Differences in performance on the FAB-C battery between uninjured participants and participants who had recently RTS following SRC

were calculated and reported using basic descriptive statistics [mean (standard deviation), median (range) or proportion as appropriate]. All analyses were performed using IBM SPSS 25 for Windows (Armonk, New York).

6.3 RESULTS

6.3.1 FAB-C battery development

Our literature search identified 13 clinical tests that are appropriate for SRC for possible inclusion in the FAB-C battery. Table 1 shows the tests with their purposes and established clinometric properties as well as our decision regarding keeping or omitting the test. This list was reduced to seven tests taking into consideration tests' purposes and clinometric properties. This included the Balance Error Scoring System, Tandem Gait Test, and Clinical Reaction Time Tests in both single and dual-task (concurrent cognitive task) testing conditions. As no sport-specific testing paradigms were identified, we included the recently proposed Sport-Related Postural Control Test to assess individuals' postural control under a sport-specific testing paradigm.[22] Finally, we incorporated a symptom checklist (The Post-Concussion Symptom Inventory)[23] to ensure the FAB-C was comprehensive. A full description of these tests follows:

The Balance Error Scoring System. The Balance Error Scoring System is commonly used to measure the sensory strategies component of postural control following SRC.[4] We administered the test as previously reported. Briefly, three stances (i.e., double, single and tandem) are held for up to 20 seconds, on both a firm and an unstable surface. Each stance is scored based on the number of errors a participant commits, with one point given for each error. Possible errors include lifting the hands off the iliac crests, opening the eyes, stepping, stumbling, falling, remaining out of

position for more than 5 seconds, moving the hip into more than 30 degrees of flexion or abduction, or lifting the forefoot or heel. A maximum of 10 points per stance is allowed. If a participant is unable to maintain a stance for 5 seconds, a maximum score of 10 was recorded for that stance. The total score of the test ranges from 0 to 60 and is calculated as the sum of the error points given for each of the six stances (see Figure 4-1).[24] For the dual-task condition, participants were asked to subtract by seven from a randomly assigned number while performing the test.[50] Consistent with previous work,[28] we scored both the single- and dual-task Balance Error Scoring System by averaging the number of errors a participant commits from three testing trials to obtain the most reliable scores.

The Tandem Gait Test. The test is currently an accepted measure of the control of dynamics component of postural control following SRC,[4] and involves walking in a forward direction as fast and accurately as possible down and back along a 38mm-wide three-meter line using an alternate foot heel-to-toe gait. During the test, the administrator records the time (in seconds) required for participants to complete the test, as well as the participants' ability to complete the test (i.e., pass/fail). Participants fail the test if they step off the line, separate their heel and toe, or touch the examiner or an object for support (see Figure 4-2). For the dual-task condition, participants are asked to spell-out a five-letter word backward while performing the test.[50] To obtain the most reliable scores for both the single- and dual-task Tandem Gait Test, we scored the time assessment by averaging time across three testing trials, and the pass/fail assessment based on a participant's performance in trial three.[28]

The Clinical Reaction Time Test. The Clinical Reaction Time Test was the only clinical (i.e., non-instrumented) test identified that measures the movement strategies (i.e., reaction time) component

of postural control following SRC. Participants sit on a chair with the dominant hand resting opened on a flat, horizontal table (see Figure 4-3) while an examiner vertically suspends a rigid 80cm cylinder coated in high-friction tape, marked in ½ cm increments, and affixed to a weighted disk at one end above the participant's hand.[51] At predetermined, random time intervals ranging from 4 to 15 seconds, the examiner releases the apparatus and the participant grasps it as quickly as possible. The distance the apparatus falls in centimeters is recorded by measuring from the top of the disk to the most superior aspect of the participant's hand. This distance is then converted to clinical reaction time, in milliseconds, using the formula for a free body falling under the influence of gravity ($d = \frac{1}{2} gt^2$; where d = distance, $g = 9.8 \text{ m/s}^2$, and t = time). For the dual-task condition, participants were asked to verbally spell a five-letter word backward while waiting for the testing apparatus to fall.[50] Consistent with previous work,[28] we scored both the single- and dual-task Clinical Reaction Time Test by averaging reaction time (in milliseconds) across three testing trials to obtain the most reliable scores.

Sport-Related Postural Control Test. Currently, there is a lack of a standardized sport-related postural control test that can be used to examine postural control recovery status following SRC.[14] In response to this issue, Manaseer et al [22] recently developed a standardized sport-related postural control test based on findings from the scientific literature on postural control assessment following SRC and feedback from experts. The test includes both a 'Turn and Go' (i.e., a sport-related postural control measure which involves forward running with repeated turning in five different directions within a limited base-of-support), and 'Lateral Shuffle' (i.e., a sport-related postural control measure which involves side-shuffle and backward running in five different directions within a limited base-of-support) components (see Figure 5-1). Both tests'

components are scored based on time (in seconds) required for participants to complete the components (i.e., running in five directions), as well as the participant's ability to complete the components (i.e., pass/fail). Tested participants fail the tests' components if they step off the assigned paths.[22] Consistent with this work,[22] we scored the time assessment by averaging time across three testing trials, and the pass/fail assessment based on a participant's ability to pass all three testing trials to obtain the most reliable scores.

The Post-Concussion Symptom Inventory. The Post-Concussion Symptom Inventory Self-assessment (ages 13 – 18) was used to document participants' symptoms before and after testing. This version of the Post-Concussion Symptom Inventory has been validated for use with individuals following SRC, with acceptable test-retest reliability (intraclass coefficients [ICC] = 0.65–0.89).[23] In the current study, participants reported symptoms before and after testing.

6.3.2 Participant characteristics

Uninjured (see Table 2): Of 59 individuals who expressed interest in study participation, seven did not meet the inclusion criteria (history of concussion within the year prior to testing), three declined to participate (time constraints), and nine did not respond to communications, leaving a sample of forty participants. The majority (70%) of uninjured participants reported hockey, basketball, ringette, or soccer as their primary sport and two (5%) participants reported current use of antibiotics for ongoing dermatological conditions.

Recently RTS following SRC (see Table 2): Of 9 individuals who expressed interest in participating in the study, one did not meet the inclusion criteria (history of lower extremity injury that caused absence from recreational/sport activities greater than one week within the last three months), and

one declined to participate (time constraints), leaving a sample of seven participants. The majority (85%) of recently concussed participants reported football and hockey as their primary sport. Four (57%) participants were initially diagnosed with SRC by a physician, and three (43%) by an athletic therapist. Three (42%) and four (58%) participants RTS based on clearance from a physician and a physical therapist, respectively. The most frequently reported criteria for making RTS decision included symptoms resolution (43%), individual ability to perform physical tasks while being symptom-free (28.5%), or both (28.5%).

6.3.3 Feasibility

All (100%) uninjured participants completed the entire assessment. Table 3 summarizes participants' performance of the FAB-C components. Table 4 shows a multitrait Spearman correlation matrix between various clinical tests included in the FAB-C battery. Intercorrelations between clinical tests included in the FAB-C battery ranged from -0.33 to 0.84. Non-significant correlations between the Balance Error Scoring System, Tandem Gait Test, Clinical Reaction Time Test, and Sport-Related Postural Control Measures were observed.

A higher number of errors on the single-task Balance Error Scoring System was associated with a higher number of errors on the dual-task Balance Error Scoring System ($r = 0.63, p < 0.001$). A longer time on the single-task Tandem Gait Test was associated with a longer time on the dual-task Tandem Gait Test ($r = 0.52, p = 0.001$). A higher number of errors on the single-task Tandem Gait Test was associated with a higher number of errors on the dual-task Tandem Gait Test ($r = 0.54, p < 0.001$). A longer time on the Turn and Go Test was associated with a longer time on the Lateral Shuffle Test ($r = 0.84, p < 0.001$).

Overall, our analysis revealed inter-item correlation coefficients that were < 0.7 between all clinical tests included in the FAB-C battery, suggesting that these assessments are measuring unique components of postural control. Despite the high correlation between the Turn and Go and Lateral Shuffle components of the sport-related postural control test ($r = 0.84$, $p < 0.001$), we decided to keep both in the FAB-C battery given that each component involves a different set of movements required for sports participation. We, therefore, did not remove any clinical tests from the FAB-C battery. Appendix 6 presents the FAB-C battery inclusive of scoring, examiner, and patient instructions.

No participants demonstrated adverse events during and/or after administering the FAB-C battery. The cost of equipment required to administer the FAB-C battery was \sim \$100 CDN. The median total time needed to administer the FAB-C battery was 49 minutes (ranging from 44 to 60 minutes).

6.3.4 Differences in performance between uninjured and injured participants

While all (100%) uninjured participants completed testing, only six (86%) participants who had recently RTS following SRC completed the entire assessment. One (14%) recently concussed participant withdrew after data collection due to the reproduction of SRC symptoms including headache, dizziness, and sadness. The percentage of uninjured participants who passed the single-task Tandem Gait Test, dual-task Tandem Gait Test, Turn and Go test, and Lateral Shuffle Test were 67%, 82%, 60%, and 52%, respectively; compared to 50%, 66%, 0%, and 17% of participants who had recently RTS following SRC, respectively (see Table 3).

Differences between uninjured participants and participants with SRC remained after stratifying the analysis by age. The percentage of youth uninjured participants ($n = 21$) who passed the single-

task Tandem Gait Test, dual-task Tandem Gait Test, and Lateral Shuffle Test were 72%, 85%, and 39%, respectively; compared to 60%, 60%, and 0% of participants who had recently RTS following SRC (n = 5), respectively. The adult participant who had recently RTS following SRC and was recruited in the current study failed the Turn and Go test, which 90% (n = 17) of uninjured adult participants (n = 19) passed.

6.4 DISCUSSION

The current study presents the FAB-C battery that aimed at targeting different components of postural control relevant to SRC. The battery consists of seven performance-based clinical tests and a symptom checklist, and is intended to be used in combination (and not in isolation) to determine a patient's postural control assessment. The battery is safe and inexpensive (i.e., its cost is comparable to the cost of the Balance Error Scoring System, which is commonly used for postural control assessment in SRC).[6] However, the total time required to administer the battery is lengthy (44 – 60 minutes).

Although the FAB-C battery requires a considerable administration time, we would argue the need for employing a comprehensive battery in clinical practice due to the fact SRC is a complex and serious injury that requires a thorough examination regardless of the time needed.[4] A thorough examination is key to lower the risk of subsequent injuries.[4] The time required to administer the battery is comparable to that required to administer a comprehensive assessment of motor skills in individuals with SRC. An example of such an assessment is the Bruininks-Oseretsky Test of Motor Proficiency Second Edition, which requires 15 – 60 minutes to administer.[52] On the other hand,

the proposed FAB-C battery is considerably less expensive than the Bruininks-Oseretsky Test of Motor Proficiency.

One approach that we suggest to minimize the time required to administer the FAB-C battery is to integrate it to the graduated RTS strategy following SRC.[4] For instance, the single-task testing paradigm of the FAB-C battery can be used acutely (24-48 hours) following SR. Once cognitive loading is introduced (stage 1 of the protocol), clinicians may use the dual-task testing paradigm to examine participants' postural control recovery status. Finally, the Sport-Related Postural Measures can be used prior to returning an injured athlete to full-contact practice (stage 5 of the protocol).[4]

Our analysis showed that more uninjured participants completed the entire FAB-C battery; and passed the single-task Tandem Gait, dual-task Tandem Gait, Turn and Go, and Lateral Shuffle tests compared to recently RTS participants (see Table 3). This observation provides preliminary evidence of the construct validity of the FAB-C battery to identify postural control impairments in youth and young adults who had recently RTS following SRC. This observation also supports previous studies suggesting that some athletes with SRC may RTS with residual postural control deficits.[13, 35]

Future studies examining the proposed FAB-C battery in active youth and young adults with a diagnosis of SRC are required before widespread use in clinical and clinical research settings. At this point, there is a need for studies examining the effect of different sources of variance (e.g., age, sex, and history of SRC) within individual clinical tests included in the FAB-C battery. Findings from these studies inform subsequent studies evaluating the clinimetric properties (i.e., validity

and reliability) of the FAB-C battery. Future studies may also examine the clinical utility of using total versus subdomain scoring of the FAB-C battery and capturing the accuracy of cognitive responses included in the battery.

If the FAB-C battery is valid and reliable, it could be clinically useful and relevant. For instance, the addition of the FAB-C battery to a standardized tool for evaluating SRC (e.g., SCAT5) will provide clinicians with a practice framework around which to assess and treat postural control deficits after SRC. Specifically, it allows differentiating which components of postural control are affected. This could then be used to inform the design of and evaluation of rehabilitation protocols that target the affected components. Likewise, the FAB-C battery may assist in identifying neuromuscular risk factors associated with increased risk for musculoskeletal injuries following SRC.[53] This may then inform the design of and evaluation of injury prevention strategies that target the identified neuromuscular risk factors.

6.4.1 Strengths and limitations

To the best of our knowledge, the current study presents the first clinical assessment of postural control that aims at differentiating between potentially affected components of postural control following SRC. This study, however, has limitations and should be interpreted in light of them. Specifically, we recruited uninjured athletes who had no SRC over the year prior to testing, and analyzed data from only participants who completed the entire assessment, which introduced selection bias (i.e., a systematic difference between those people who volunteered to be part of the study and the population).[54] The clinical tests used under the dual-task and sport-specific domains of the FAB-C battery have not been previously validated, which introduced measurement

bias (i.e., a systematic error that can occur in collecting relevant data).[54] The generalizability of our findings is limited as the majority of the participants were uninjured (85%), male (63%), or athletes who played hockey, ringette, basketball, or soccer (60%). Also, generalizability to other environments (e.g., the field of play) and testing conditions (e.g., shoes off) should be done with caution as participants were tested in a physiotherapy clinic and a university laboratory with their shoes on.

Overall, more than 30% of the recruited sample failed the pass/fail component of the Tandem Gait, Turn and Go, and Lateral Shuffle tests which suggests the presence of a floor effect. The difficulty of cognitive tasks included in the dual-task testing category of the FAB-C battery may vary based on education and math ability.

6.5 CONCLUSION

To the best of our knowledge, the current study presents the first clinical assessment of postural control (i.e., the FAB-C battery) that aims at differentiating between the potentially affected components of postural control following SRC. The battery is safe, feasible, and inexpensive. Additionally, the battery demonstrated preliminary construct validity to identify postural control impairments in youth and young adults who had recently RTS following SRC. However, further developmental studies evaluating the effect of different sources of variance within individual clinical tests included in the FAB-C battery, as well as the clinimetric properties and clinical utility of the FAB-C battery are required before widespread use in clinical settings.

6.6 REFERENCES

- 1.Han J, Anson J, Waddington G, Adams R, Liu Y. The role of ankle proprioception for balance control in relation to sports performance and injury. *Biomed Res Int.* 2015;2015:842804.
- 2.Horak FB. Postural orientation and equilibrium: what do we need to know about neural control of balance to prevent falls? *Age Ageing.* 2006;35 Suppl 2(SUPPL.2):ii7-ii11.
- 3.Sibley KM, Beauchamp MK, Van Ooteghem K, Straus SE, Jaglal SB. Using the systems framework for postural control to analyze the components of balance evaluated in standardized balance measures: a scoping review. *Arch Phys Med Rehabil.* 2015;96(1):122-32 e29.
- 4.McCrory P, Meeuwisse W, Dvorak J, Aubry M, Bailes J, Broglio S, et al. Consensus statement on concussion in sport-the 5(th) International Conference on Concussion in Sport held in Berlin, October 2016. *Br J Sports Med.* 2017;51(11):838-47.
- 5.Corwin DJ, Wiebe DJ, Zonfrillo MR, Grady MF, Robinson RL, Goodman AM, et al. Vestibular deficits following youth concussion. *J Pediatr.* 2015;166(5):1221-5.
- 6.Murray N, Salvatore A, Powell D, Reed-Jones R. Reliability and validity evidence of multiple balance assessments in athletes with a concussion. *J Athl Train.* 2014;49(4):540-9.
- 7.McCrea M, Guskiewicz KM, Marshall SW, Barr W, Randolph C, Cantu RC, et al. Acute effects and recovery time following concussion in collegiate football players: the NCAA Concussion Study. *JAMA.* 2003;290(19):2556-63.

8. Manaseer TS GD, Mrazik M, Schneider K, Whittaker JL. Re-conceptualizing postural control assessment in sport-related concussion: Transitioning from the Reflex/Hierarchical Model to the Systems Model. *Physiother Theory Pract.* 2019;Aug(1):1-2.
9. Buckley TA, Oldham JR, Caccese JB. Postural control deficits identify lingering post-concussion neurological deficits. *Sport Sci Health.* 2016;5(1):61-9.
10. Johnston W, Coughlan GF, Caulfield B. Challenging concussed athletes: the future of balance assessment in concussion. *QJM.* 2016;110(12):779-83.
11. Reed-Jones RJ, Murray NG, Powell DW. Clinical assessment of balance in adults with concussion. *Semin Speech Lang.* 2014;35(03):186-95.
12. Muro-de-la-Herran A, Garcia-Zapirain B, Mendez-Zorrilla A. Gait analysis methods: an overview of wearable and non-wearable systems, highlighting clinical applications. *Sensors.* 2014;14(2):3362-94.
13. Cross M, Kemp S, Smith A, Trewartha G, Stokes K. Professional Rugby Union players have a 60% greater risk of time loss injury after concussion: a 2-season prospective study of clinical outcomes. *Br J Sports Med.* 2016;50(15):926-31.
14. Manaseer TS, Gross DP, Mrazik M, Schneider K, Whittaker JL. Re-conceptualizing postural control assessment in sport-related concussion: Transitioning from the reflex/hierarchical model to the systems model. *Physiother Theory Pract.* 2019:1-12.

15. Smith FW, Rosenlund EA, Aune AK, MacLean JA, Hillis SW. Subjective functional assessments and the return to competitive sport after anterior cruciate ligament reconstruction. *Br J Sports Med.* 2004;38(3):279-84.
16. Clay MB, Glover KL, Lowe DT. Epidemiology of concussion in sport: a literature review. *J Chiropr Med.* 2013;12(4):230-51.
17. Gardner AJ, Quarrie KL, Iverson GL. The epidemiology of sport-related concussion: what the rehabilitation clinician needs to know. *J Orthop Sports Phys Ther.* 2019;49(11):768-78.
18. Chaouachi A, Castagna C, Chtara M, Brughelli M, Turki O, Galy O, et al. Effect of warm-ups involving static or dynamic stretching on agility, sprinting, and jumping performance in trained individuals. *J Strength Cond Res.* 2010;24(8):2001-11.
19. Echemendia RJ, Meeuwisse W, McCrory P, Davis GA, Putukian M, Leddy J, et al. The Sport Concussion Assessment Tool 5th Edition (SCAT5): background and rationale. *Br J Sports Med.* 2017;51(11):848-50.
20. Jacqueline M SPRM. Evaluating evidence for conceptually related constructs using bivariate correlations. *Meas Eval Couns Dev.* 2017;50(4):270-4.
21. de Vet HC, Terwee CB, Mokkink LB, Knol DL. *Measurement in medicine: a practical guide.*: Cambridge University Press; 2011.

22. Manaseer TS WJ, Codi Issac, Schneider K, Gross DP. The rationale for, development and preliminary evaluation of the Functional Assessment of Balance in Concussion (FAB-C) Battery [dissertation]. University of Alberta; 2020.
23. Sady MD, Vaughan CG, Gioia GA. Psychometric characteristics of the postconcussion symptom inventory in children and adolescents. *Arch Clin Neuropsychol*. 2014;29(4):348-63.
24. Riemann BL, Guskiewicz KM, Shields EW. Relationship between clinical and forceplate measures of postural stability. *J Sport Rehabil*. 1999;8(2):71-82.
25. Bell DR, Guskiewicz KM, Clark MA, Padua DA. Systematic review of the Balance Error Scoring System. *Sports Health*. 2011;3(3):287-95.
26. Barlow M, Schlabach D, Peiffer J, Cook C. Differences in change scores and the predictive validity of three commonly used measures following concussion in the middle school and high school aged population. *Int J Sports Phys Ther*. 2011;6(3):150.
27. Ross LM, Register-Mihalik JK, Mihalik JP, McCulloch KL, Prentice WE, Shields EW, et al. Effects of a single-task versus a dual-task paradigm on cognition and balance in healthy subjects. *J Sport Rehabil*. 2011;20(3):296-310.
28. Manaseer TS WJ, Isaac C, Schneider K, Roberts MR, Gross DP. The reliability of clinical balance tests under single-task and dual-task testing paradigms in uninjured active youth and young adults. *Int J Sports Phys Ther* 2019;[in press].

29. Eckner JT, Richardson JK, Kim H, Joshi MS, Oh YK, Ashton-Miller JA. Reliability and criterion validity of a novel clinical test of simple and complex reaction time in athletes. *Percept Mot Skills*. 2015;120(3):841-59.
30. Eckner JT, Kutcher JS, Broglio SP, Richardson JK. Effect of sport-related concussion on clinically measured simple reaction time. *Br J Sports Med*. 2014;48(2):112-8.
31. Shumway-Cook A, Baldwin M, Polissar NL, Gruber W. Predicting the probability for falls in community-dwelling older adults. *Phys Ther*. 1997;77(8):812-9.
32. Wrisley DM, Walker ML, Echternach JL, Strasnick B. Reliability of the dynamic gait index in people with vestibular disorders. *Arch Phys Med Rehabil*. 2003;84(10):1528-33.
33. Legters K, Whitney SL, Porter R, Buczek F. The relationship between the activities-specific Balance Confidence Scale and the Dynamic Gait Index in peripheral vestibular dysfunction. *Physiother Res Int*. 2005;10(1):10-22.
34. Whitney S, Wrisley D, Furman J. Concurrent validity of the Berg Balance Scale and the Dynamic Gait Index in people with vestibular dysfunction. *Physiother Res Int*. 2003;8(4):178-86.
35. Manaseer TS, Gross DP, Dennett L, Schneider K, Whittaker JL. Gait deviations associated with concussion: A Systematic Review [published online ahead of print, 2017 Nov 21]. *Clin J Sport Med*. 2017;10.1097/JSM.0000000000000537. doi:10.1097/JSM.000000000000053

36. Whitney SL, Wrisley DM, Marchetti GF, Gee MA, Redfern MS, Furman JM. Clinical measurement of sit-to-stand performance in people with balance disorders: validity of data for the Five-Times-Sit-to-Stand Test. *Phys Ther.* 2005;85(10):1034-45.
37. Lord SR, Murray SM, Chapman K, Munro B, Tiedemann A. Sit-to-stand performance depends on sensation, speed, balance, and psychological status in addition to strength in older people. *J Gerontol A Biol Sci Med Sci.* 2002;57(8):M539-43.
38. Alsalaheen BA, Whitney SL, Marchetti GF, Furman JM, Kontos AP, Collins MW, et al. Relationship between cognitive assessment and balance measures in adolescents referred for vestibular physical therapy after concussion. *Clin J Sport Med.* 2016;26(1):46.
39. Wrisley DM, Marchetti GF, Kuharsky DK, Whitney SL. Reliability, internal consistency, and validity of data obtained with the functional gait assessment. *Phys Ther.* 2004;84(10):906-18.
40. Lanska DJ, Goetz CG. Romberg's sign: development, adoption, and adaptation in the 19th century. *Neurology.* 2000;55(8):1201-6.
41. Koyama S, Tanabe S, Itoh N, Saitoh E, Takeda K, Hirano S, et al. Intra- and inter-rater reliability and validity of the tandem gait test for the assessment of dynamic gait balance. *Eur J Physiother.* 2018;20(3):135-40.
42. Galetta KM, Morganroth J, Moehringer N, Mueller B, Hasanaj L, Webb N, et al. Adding vision to concussion testing: a prospective study of sideline testing in youth and collegiate athletes. *J Neuroophthalmol.* 2015;35(3):235-41.

43. Howell DR, Osternig LR, Chou LS. Single-task and dual-task tandem gait test performance after concussion. *J Sci Med Sport*. 2017;20(7):622-6.
44. Podsiadlo D, Richardson S. The timed “Up & Go”: a test of basic functional mobility for frail elderly persons. *J Am Geriatr Soc*. 1991;39(2):142-8.
45. Steffen TM, Hacker TA, Mollinger L. Age- and gender-related test performance in community-dwelling elderly people: Six-Minute Walk Test, Berg Balance Scale, Timed Up & Go Test, and gait speeds. *Phys Ther*. 2002;82(2):128-37.
46. Ries JD, Echternach JL, Nof L, Gagnon Blodgett M. Test-retest reliability and minimal detectable change scores for the timed “Up & Go” Test, the Six-Minute Walk Test, and gait speed in people with Alzheimer disease. *Phys Ther*. 2009;89(6):569-79.
47. Hyndman D, Ashburn A. “Stops walking when talking” as a predictor of falls in people with stroke living in the community. *J Neurol Neurosurg Psychiatry*. 2004;75(7):994-7.
48. Verghese J, Buschke H, Viola L, Katz M, Hall C, Kuslansky G, et al. Validity of divided attention tasks in predicting falls in older individuals: a preliminary study. *J Am Geriatr Soc*. 2002;50(9):1572-6.
49. Schneider KJ, Palacios-Derflingher L, Meeuwisse WH, Emery CA. Changes in measures of cervical, vestibular, dynamic balance and tasks of divided attention following sport-related concussions in elite youth ice hockey players. *Br J Sports Med*. 2017;51(11):A47-A8.

50. Register-Mihalik JK, Littleton AC, Guskiewicz KM. Are divided attention tasks useful in the assessment and management of sport-related concussion? *Neuropsychol Rev.* 2013;23(4):300-13.
51. Eckner JT, Whitacre RD, Kirsch NL, Richardson JK. Evaluating a clinical measure of reaction time: an observational study. *Percept Mot Skills.* 2009;108(3):717-20.
52. Grinnon ST, Miller K, Marler JR, Lu Y, Stout A, Odenkirchen J, et al. National institute of neurological disorders and stroke common data element project—approach and methods. *Clin Trials.* 2012;9(3):322-9.
53. McPherson AL, Nagai T, Webster KE, Hewett TE. Musculoskeletal injury risk after sport-related concussion: a systematic review and meta-analysis. *Am J Sports Med.* 2018;47(7):1754-62.
54. Krishna R, Maithreyi R, Surapaneni K. Research bias: a review for medical students. *J Clin Diagn Res.* 2010;4(2):2320-4.

6.7 TABLES

Table 6-1: Candidate Clinical Tests for Possible Inclusion in the Functional Assessment of Balance in Concussion (FAB-C) Battery

Table 2. Candidate Clinical Tests for Possible Inclusion in the Functional Assessment of Balance in Concussion (FAB-C) battery

Clinical Test	Evaluated Component of Postural Control	Established Clinimetric Properties	Decision and Justification
Balance Error Scoring System [24]	Sensory strategies [3]	<ul style="list-style-type: none"> - Intra- and inter-rater reliability in uninjured athletes ranged from an ICC of 0.57 to 0.98.[25] - Criterion-related validity has been shown by correlating the test with target sway in male athletes ($r = 0.31 - 0.79, p < 0.01$,[25] and 	<ul style="list-style-type: none"> - Included: The Balance Error Scoring System is a commonly accepted clinical test to challenge the sensory strategies component of postural control.

		<p>Immediate Post-Concussion Assessment and Cognitive Testing (ImPACT) in youth with concussion ($r = -0.31$).[26]</p> <ul style="list-style-type: none"> - The test detected postural control impairments in athletes with sport-related concussion.[25] - The test is recommended by the Concussion in Sport Group.[4] 	
<p>Balance Error Scoring System + cognitive task [27]</p>	<p>Sensory strategies[3] and cognitive contributions[27]</p>	<ul style="list-style-type: none"> - Intra- and inter-rater reliability ICCs in uninjured youth and young adult athletes were 0.94 and 0.98, respectively.[28] 	<ul style="list-style-type: none"> - Included: The only available clinical test to challenge the sensory strategies component of postural control under dual-task testing condition.

<p>Clinical Reaction Time [29]</p>	<p>Reaction time[29]</p>	<ul style="list-style-type: none"> - Intra- and inter-rater reliability has been previously examined in uninjured athletes with ICCs ranging between 0.74 and 0.76.[29] - Criterion-related validity has been shown by correlating the test with computerized reaction times ($r=0.54$, p-value not provided) in uninjured athletes.[29] - In collegiate athletes, the test differentiated concussed from uninjured athletes. The sensitivity and specificity of the test were 75% and 68%, respectively, with a reliable change index of 65%.[30] 	<ul style="list-style-type: none"> - Included: The only available clinical test to challenge reaction time.
<p>Clinical Reaction Time +</p>	<p>Reaction time[29] and cognitive</p>	<ul style="list-style-type: none"> - Intra- and inter-rater reliability ICCs in uninjured youth and young adult athletes were 0.90 and 0.70, respectively.[28] 	<ul style="list-style-type: none"> - Included: The only available clinical test to challenge reaction time under dual-task condition.

cognitive task [29]	contributions[29]		
Dynamic Gait Index [31]	Control of dynamics, sensory strategies, anticipatory postural control, and cognitive contributions[31]	<ul style="list-style-type: none"> - Inter-rater reliability Kappa statistic in individuals with vestibular disorders =0.64.[32] - Concurrent validity has been shown by correlating the test with the Balance Confidence Scale ($r = 0.58, p < 0.001$) [33] and the Berg Balance Scale ($r = 0.71; p < 0.01$) in individuals with vestibular disorders.[34] 	<ul style="list-style-type: none"> - Excluded: The Dynamic Gait index is traditionally used in the assessment of patients at risk of falling. It is subjective in nature and may not be challenging enough to elicit deficits in an athletic population. It does not consider medial-lateral center-of-mass control and walking speed that are sensitive to identify deficits in gait following sport-related concussion.[35]
Five Times Sit to Stand Test [36]	Control of dynamics and anticipatory	<ul style="list-style-type: none"> - The test demonstrated good reliability (ICC = 0.89) in older community-living adults.[37] 	<ul style="list-style-type: none"> - Excluded: The test score is the amount of time it takes a patient to transfer from a seated to a standing position and back to

	<p>postural control[3]</p>	<ul style="list-style-type: none"> - The test could correctly identify 65% of participants with postural control dysfunction.[36] - Concurrent validity has been shown by correlating the test with the Dynamic Gait Index ($r = -0.68, p < 0.001$) and the Activities-specific Balance Confidence Scale ($r = -0.58, p < 0.001$) in participants with postural control dysfunction.[36] - The test correlated with visual memory ($r = -0.38, p = 0.010$), reaction time ($r = 0.38, p = 0.010$), and verbal memory ($r = -0.50, p < 0.001$) components of the Immediate Post-Concussion Assessment and Cognitive 	<p>sitting five times. It does not assess a patient's ability to walk.</p>
--	----------------------------	---	--

		Testing (ImPACT) in youth with concussion.[38]	
Functional Gait Assessment [39]	Control of dynamics, sensory strategies, anticipatory postural control, and cognitive contributions [3]	<ul style="list-style-type: none"> - Intra- and inter-rater reliability ICCs in individuals with vestibular disorders were 0.74 and 0.86, respectively.[39] - Concurrent validity has been shown by correlating the test with postural control and gait measurements ($r = 0.11 - 0.67$) in individuals with vestibular disorders.[39] - The test correlated with visual memory ($r = 0.4$, $p = 0.003$) and verbal memory ($r = 0.44$, $p = 0.001$) components of the Immediate Post-Concussion Assessment and Cognitive Testing (ImPACT) in youth with concussion.[38] 	- Excluded: The Functional Gait Assessment is a modification of the Dynamic Gait Index, developed to improve reliability and reduce ceiling effect. Although the assessment includes testing participants' ability to tandem walk for a distance of 3.6 meters, participants' performance is scored based on the number of steps taken without considering medial-lateral center-of-mass control and walking speed that are sensitive to identify deficits in gait following sport-related concussion.[35]

Romberg Test [40]	Sensory strategies [6]	<ul style="list-style-type: none"> - There is no consensus on the reliability and validity of this test in the literature - The sensitivity and specificity of the test to identify individuals with sport-related concussion were 0.55 and 0.77, respectively.[6] 	<ul style="list-style-type: none"> - Excluded: Limited clinimetric properties.
Sport-Related Postural Control Test [22]	Control of dynamics, sensory strategies, anticipatory postural control, and cognitive	<ul style="list-style-type: none"> - Based on the evaluated test's individual components, intra- and inter-rater reliability ICCs for the time assessment in uninjured youth and young adult athletes ranged from 0.85 to 0.97.[22] - Intra- and inter-rater reliability Kappa statistics for the pass/fail assessment in uninjured youth and young adult athletes ranged from 0.23 to 0.90.[22] 	<ul style="list-style-type: none"> - Included: The only available measure to challenge postural control ability under a sport-specific condition.

	contributions [22]		
† Tandem Gait Test [19]	Control of dynamics[19]	<ul style="list-style-type: none"> - Intra- and inter-rater reliability ICCs of the time assessment in uninjured adults ranged from 0.70 to 0.95.[41] - Intra- and inter-rater reliability ICCs of the time assessment in uninjured youth and young adults were 0.54 to 0.99, respectively.[28] - Intra- and inter-rater reliability Kappa statistics of the pass/fail assessment in uninjured youth and young adults ranged from 0.37 to 0.83.[28] - Concurrent validity of the time assessment has been shown by correlating the test with 	<ul style="list-style-type: none"> - Included: The Tandem Gait Test is a commonly accepted measure to challenge medial-lateral center-of-mass control and walking speed that are sensitive to identify deficits in gait following sport-related concussion.[35]

		<p>the Timed Up and Go test scores in uninjured adults.[41]</p> <ul style="list-style-type: none"> - The test accurately discriminated between injured and uninjured youth and collegiate athletes immediately following SRC (Area Under the Curve = 0.87).[42] - The test is recommended by the Concussion in Sport Group.[4] 	
<p>Tandem Gait Test + cognitive task [43]</p>	<p>Control of dynamics and cognitive contributions [43]</p>	<ul style="list-style-type: none"> - Intra- and inter-rater reliability ICCs for the time assessment in uninjured youth and young adult athletes were 0.94 and 0.99, respectively.[28] - Intra- and inter-rater reliability Kappa statistics of the pass/fail assessment in 	<ul style="list-style-type: none"> - Included: The only available measure to challenge medial-lateral center-of-mass control and walking speed that are sensitive to identify deficits in gait following sport-related concussion [35] under dual-task testing condition.

		uninjured youth and young adults ranged from 0.37 to 0.83.[28]	
Timed Up and Go [44]	Control of dynamics and anticipatory postural control [3]	<ul style="list-style-type: none"> - Reliability ICCs in elderly populations ranged from 0.56 to 0.99.[45] - Reliability ICCs in individuals with Alzheimer’s disease ranged from 0.985 to 0.988.[46] - Construct validity has been shown by correlating the test scores with gait speed ($r = 0.75$), postural sway ($r = - 0.48$), step length ($r = - 0.74$), Barthel Index ($r = - 0.79$), and step frequency ($r = - 0.59$).[45] 	- Excluded: The Timed Up and Go is traditionally used in the assessment of patients at risk of falling. It may not be challenging enough to elicit deficits in an athletic population. It does not consider medial-lateral center-of-mass control and walking speed that are sensitive to identify deficits in gait following sport-related concussion.[35]
Walking-While-	Control of dynamics and cognitive	- Inter-rater reliability has been examined and found to be moderate in community-dwelling older individuals ($r = 0.602$, $P < .001$).[48]	- Excluded: The Walking-While-Talking Test was developed to predict falls in old individuals. It may not be challenging

<p>Talking Test [47]</p>	<p>contributions [47]</p>	<p>- In one study, elite youth ice hockey players with concussion required less time to complete the test compared to normal walking speed.[49]</p>	<p>enough to elicit deficits in an athletic population. It does not consider medial-lateral center-of-mass control and walking speed that are sensitive to identify deficits in gait following sport-related concussion.[35]</p>
------------------------------	-------------------------------	---	--

Table 6-2: Participant Characteristics**Table 2: Participant Characteristics (n=47)**

Characteristics	Uninjured (n=40)	Injured (n=7)
Sex (female), n (%)	12 (30%)	1 (14.2%)
Age (years), median (min-max)	17 (13–24)	17 (13-20)
History of previous concussion (yes), n (%)	13 (32.5%)	4 (57%)
Current medication (yes), n (%)	2 (5%)	0 (0%)
Days since injury to return-to-play, median (min-max)	NA	31 (9-40)
Days since return-to-play to testing, median (min-max)	NA	34 (9-46)

Table 6-3: Summary Statistics for Participant Performance on the FAB-C Battery

Table 3. Summary Statistics for Participant Performance on the FAB-C Battery (n=46)

Task	Uninjured (n=40)	Injured (n=6)
BESS-ST (number of errors)	16 (26)	15 (10)
TGTT-ST (seconds)	19 (14)	16 (8)
TGTE-ST (% passing)	67	50
CRT-ST (millisecond)	250 (80)	238 (73)
BESS-DT (number of errors)	14 (30)	13 (21)

TGTT-DT (seconds)	19 (23)	17 (10)
TGTE-DT (% passing)	82	66
CRT-DT (millisecond)	250 (110)	230 (60)
Turn and Go (seconds)	18 (8)	17 (5)
Turn and Go (% passing)	60	0
Lateral Shuffle (seconds)	17 (9)	17 (4)
Lateral Shuffle (% passing)	52	17

Note. None of the recruited participants reported sport-related concussion related symptoms after performing the FAB-C battery. Values are presented as median (range) unless otherwise noted. Data from one injured participant who did not complete the entire testing

protocol was excluded from the analysis. BESS: Balance Error Scoring System, CRT: Clinical Reaction Time, DT: dual-task, FAB-C battery: the Functional Assessment of Balance in Concussion battery, Lateral Shuffle: a sport-related postural control measure that involves side-shuffling and backward running, ST: single-task, TGTT: Tandem Gait Test (time), TGTE: Tandem Gait Test (error), Turn and Go: a sport-related postural control measure that involves forward running and turning

Table 6-4: Multitrait Spearman Correlation Matrix among Postural Control Tests in Healthy Control Participants

Table 4: Multitrait Spearman Correlation Matrix among Postural Control Tests in Healthy Control Participants (n=40)

	1	2	3	4	5	6	7	8	9	10	11	12
1. BESS-ST	-											
2. TGTT-ST	0.09	-										
3. TGTE-ST	0.42*	-0.19	-									
4. RT-ST	-0.30	0.18	-0.14	-								
5. BESS-DT	0.63**	0.10	.41	-0.06	-							

6. TGTT-DT	0.18	0.52**	-0.03	0.11	0.25	-						
7. TGTE-DT	0.27	0.15	0.54**	-0.01	0.29	0.01	-					
8. RT-DT	-0.10	0.18	-0.01	0.15	-0.12	0.01	0.14	-				
9. Turn and Go (second)	0.26	0.14	0.21	-0.13	0.19	0.08	0.38*	0.03	-			
10. Turn and Go (%pass)	0.19	0.07	0.18	0.13	0.29	0.07	0.00	-0.14	-0.23	-		
11. Lateral Shuffle (second)	0.29	0.15	0.24	-0.11	0.20	0.21	0.36*	0.04	0.84**	-0.17	-	
12. Lateral Shuffle (%pass)	0.12	-0.12	0.19	-0.07	0.04	0.13	-0.01	0.34*	-0.33*	0.35*	-0.18	-

Note. Numbers in the top row represent the same measures listed in the first column. Dashes along the diagonal represent perfect correlation ($r = 1.0$). *Correlations are significant at 0.05 level (2-tailed). ** Correlations are significant at 0.001 level (2-tailed). BESS:

Balance Error Scoring System, CRT: Clinical Reaction Time, DT: dual-task, ST: single-task, Lateral Shuffle: a sport-related postural control measure that involves side-shuffling and backward running, TGTT: Tandem Gait Test (time), TGTE: Tandem Gait Test (error), Turn and Go: a sport-related postural control measure that involves forward running and turning.

CHAPTER 7– GENERAL DISCUSSION AND CONCLUSIONS

7.1 INTRODUCTION

Postural control impairments are frequently detected following sport-related concussion (SRC).[1] Although there has been an extensive amount of work in the area of postural control assessment following SRC, there is a need for more sensitive clinical postural control assessment tools to inform appropriate return-to-play (RTP) decisions.[1] This dissertation presents a theoretical foundation for, development and preliminary evaluation of a novel clinical postural control assessment tool called the Functional Assessment of Balance in Concussion (FAB-C) battery. This chapter will provide a brief synopsis of the findings of the included studies, a discussion of the contributions these studies have made to the field of SRC and their limitations. The chapter will conclude with implications of the findings for clinical practice, and suggested future directions and knowledge translation activities.

7.2 THEORETICAL FOUNDATIONS OF THE FAB-C

7.2.1 Gait deviations following sport-related concussion

Gait is a functional task that is commonly evaluated to assist with concussion diagnosis, treatment progression, and return to activity, sport, recreation, and/or work decisions. Although other groups have performed systematic reviews in individuals who have suffered an SRC, [2-4] the systematic review presented in chapter two is the first to incorporate an assessment of study quality and highlight gait deviations associated with concussion across a broad range of populations while taking into consideration time since the initial injury. A novel finding of this systematic review is

that concussion-associated gait deficits (i.e., increased medial-lateral center-of-mass displacement and decreased gait velocity) may persist beyond the typical 10-day recovery period after a concussion, and after return to activity, sport, recreation, and work.[5] Not only did this finding inform subsequent studies in this dissertation, it has 40 downloads and 5 citations since publication, and will also continue to inform the direction and design of future research in the area of dynamic postural control assessment following SRC.

7.2.2 Shifting the framework for understanding postural control in sport-related concussion

Our framework for understanding of how posture is controlled shapes how we approach the assessment of postural control impairments.[6] Traditionally, SRC postural control impairment has been viewed as a unidimensional construct that stems from the central nervous systems' inability to integrate sensory input to control posture as described by the Reflex/Hierarchical Model.[7] This has led to assessment of postural control impairments following SRC using methods that only challenge the ability to integrate sensory information in the brain (e.g., the Balance Error Scoring System). In recent years, the Reflex/Hierarchical model is less often referenced due to its lack of consideration of motor and cognitive resources required for postural control.[8] Hence, there has been a shift away from using the Reflex/Hierarchical Model towards the Systems Model when describing the physiological basis of postural control and to guide the design of new assessment techniques evaluating postural control.[8]

The narrative review in chapter three is the first to apply the Systems Model to the assessment of SRC. Compared to other reviews on SRC,[9, 10] this review specifies the potentially affected components of postural control following SRC (i.e., sensory strategies [i.e., impaired sensory

integration], control of dynamics [i.e., increased medial-lateral center-of-mass displacement and decreased gait velocity], movement strategies [i.e., prolonged reaction time], and cognitive contributions [i.e., impaired dual-task performance]). Moreover, the review provides a novel model for postural control assessment following SRC that considers all potentially affected components (see Figure 3-2). Not only did these findings inform subsequent studies in this dissertation, they have 50 downloads since publication, and will also continue to inform the direction and design of future research in the area of postural control assessment following SRC.

7.3 A NOVEL CLINICAL POSTURAL CONTROL ASSESSMENT TOOL (THE FAB-C)

The development of the FAB-C was guided by the new model of postural control assessment in SRC that is presented in Figure 3-2, and was compiled by including existing clinical tests that assessed potentially impacted components of postural control (i.e., the Balance Error Scoring System, Tandem Gait Test, and Clinical Reaction Time Test under both single- and dual-task testing conditions). New clinical tests were developed where none existed in the published literature (i.e. sport-related postural control test).

7.3.1 Tests considered for inclusion into the FAB-C

Currently, postural control assessment within the context of SRC relies on single-task testing (i.e., controlling posture without a concurrent cognitive task).[11, 12] The valid and reliable Balance Error Scoring System,[11] Tandem Gait Test,[11] and Clinical Reaction Time Test [13] are examples of single-task tests that are frequently used to challenge sensory strategies, control of

dynamics, and movement strategies components of postural control following an SRC, respectively.[14]

Although cognitive abilities are frequently assessed after an SRC, pairing of a cognitive and postural control task (i.e., dual-task testing) may allow for identifying deficits in postural control that are not identified through single-task postural control or cognitive testing alone.[12] Currently, there is no tool that has been demonstrated to be feasible and reliable in assessing clinical dual-task measures of sensory strategies, control of dynamics, and movement strategies. That said, adding a cognitive task to the Balance Error Scoring System,[15] Tandem Gait Test,[16] and Clinical Reaction Time Test [17] would fill this gap.

The study in chapter four examines the reliability of the Balance Error Scoring System, Tandem Gait Test, and Clinical Reaction Time Test under both single- and dual-task testing conditions in a sample of uninjured active youth and young adults (median age=17; range 13-24). The findings suggest that averaging the scores from three trials of these tests produce higher reliability under all conditions. In contrast, we demonstrated lower intra-rater reliability for the single-task Tandem Gait Test (ICC 95%CI; 0.54 [0,0.79]) compared to a recent report (ICC 95%CI; 0.86 [0.73,0.93]).[16] This may be attributed to differences in the age and heterogeneity of scores between samples. Overall, dual-task testing demonstrated higher relative reliability estimates (ICC ranged from 0.70 to 0.99) compared to single-task testing (ICC ranged from 0.14 to 0.99). This observation further supports the previously suggested higher utility of dual-task testing to identify postural control impairments in SRC.[18] All tests under all conditions demonstrated a systematic error (i.e., participants' performance improved between testing trials and testing sessions) suggesting the possibility of a learning effect. This study also presented a novel assessment of the

subjective pass/fail scoring criterion of the Tandem Gait Test used in the Sport Concussion Assessment Tool (SCAT; versions 5 [SCAT5]) under both single- and dual-task testing conditions. Findings suggest that higher intra-rater and inter-rater reliability estimates are obtained by administering the Tandem Gait Test three times and documenting the score from trial three for both testing conditions (Kappa Statistic ranged from 0.37 to 0.83).

Despite the complexity of dual-task testing, it does not replicate the conditions that challenge an athletes' ability to control posture while performing specialized sport movements. Thus, there is a need to develop a sport-specific test to assist in RTP decisions following an SRC.[19, 20] The study in chapter five presented the development of and examined the reliability of a novel sport-related postural control test to assess postural control in SRC. The test was developed based on findings from the scientific literature in addition to feedback from experts and participants. The test consisted of two components including the 'Turn and Go' (i.e., a sport-related postural control measure which involves forward running with repeated turning in five different directions within a limited base-of-support), and 'Lateral Shuffle' (i.e., a sport-related postural control measure which involves side-shuffle and backward running in five different directions within a limited base-of-support). Both test components were scored based on time (in seconds) required for participants to complete the components, as well as a subjective assessment of the participants' ability to complete the components (i.e., pass/fail). Both test components demonstrated acceptable reliability (ICC ranged from 0.85 to 0.97) in uninjured active youth and young adults (median age=17; range 13-24). Participants' performance improved between testing trials and testing sessions suggesting the possibility of a learning effect for both test components.

7.3.2 Introducing the FAB-C

Appendix 6 presents the FAB-C inclusive of scoring, examiner, and patient instructions. The FAB-C included the Balance Error Scoring System, Tandem Gait, Clinical Reaction Time (single- and dual-task conditions), and sport-related postural control test. A symptom checklist was added to the FAB-C to enhance its comprehensiveness. Compared to individual tests for postural control in SRC (e.g., the Balance error Scoring System, Tandem Gait Test, and Clinical Reaction Time Test),[21, 22] the FAB-C is more comprehensive (i.e., targets all potentially affected components of postural control following an SRC) and challenging (i.e., examines one's postural control ability while performing specialized sport movements). Further, the FAB-C includes both performance-based and patient-reported outcome measures which together may provide a better understanding of an individual's postural control ability.

7.4 PRELIMINARY EVALUATION OF THE FAB-C

The cross-sectional study in chapter six examined the feasibility and preliminary construct validity of the FAB-C. Findings from this study suggested that the FAB-C is feasible (no item redundancy [correlation coefficients between included tests were <0.7], and has low cost [<100 CAD]). The FAB-C also demonstrated preliminary construct validity by identifying differences in performance between uninjured ($n=40$, 30% female, median age 17 years) and concussed ($n=7$, 14% female, median age 17 years) active individuals. Specifically, a greater percentage of uninjured participants (52% to 82%) passed individual battery component tests compared to participants with SRC (17% to 66%). That said, the FAB-C administration time is lengthy [44-60 minutes], which limits its utility as a one-time testing battery in clinical practice.

7.5 LIMITATIONS OF THE RESEARCH

Although specific limitations to each investigation were discussed in the relevant chapters, there are some common limitations to the studies contained within this dissertation that need to be addressed including the potential for selection bias, influence of potential confounders, generalizability findings and random error.

For the study in Chapter six, we attempted to optimize recruitment of potential participants through many mechanisms. The original target sample was 60 athletes (i.e., 30 with SRC vs 30 uninjured athletes). However, the final sample that we were able to recruit was forty-seven athletes (i.e., seven with SRC vs 40 uninjured athletes). It was difficult to gather a large sample of athletes with SRC that were willing to complete multiple testing sessions required in this study. In some cases this was due to limited availability of participants whereas in other cases it was due to clinician availability not lining up with participant availability. Despite flexible testing schedules, the use of two testing sites and frequent meetings with onsite clinicians to facilitate recruitment we were unable to recruit the number of participants that were originally estimated. In Chapters four and five, the inclusion of more athletes with SRC could have increased the heterogeneity of the characteristics of our sample. Thus, our sample was likely more homogeneous than what would have been expected and, consequently, this may have resulted in our agreement coefficients being lower (i.e., ICC), and the precision estimates (i.e., standard error of measurement and minimal detectable change) higher than what would be expected with a more heterogeneous population. Furthermore, the inclusion of more athletes with SRC in Chapter six would have resulted in greater power to detect a difference and may have reduced the possibility of committing type two error (i.e., concluded there was not a significant difference between two groups when there was).

Selection bias is another potential limitation of this research. Selection bias is introduced when systematic differences occur between those who participate in a study and those who do not with respect to the outcome of interest.[23] Studies in Chapters four and five included uninjured active individuals who came from specific facilities. Thus, it is possible that participants' scores did not vary greatly from one another and, consequently, low estimates of agreement (i.e., ICC) and high estimates of precision (i.e., standard error of measurement) were obtained.[24] Accordingly, we possibly underestimated the agreement and precision of the Balance Error Scoring System, Tandem Gait Test, Clinical Reaction Time Test, and/or sport-related postural control test.[24]

By definition, a confounder is “a variable whose presence affects the variables being studied so that the results do not reflect the actual relationship”.[25] According to previous studies, potential confounders that might have affected participants' performance in Chapters four, five and six include the history of previous lower extremity injury greater than three months before testing [26] and history of previous concussions.[27] Individuals with a previous history of lower extremity injury and/or concussion may have performed more poorly on clinical tests included in Chapters four and five, which may have increased the variability in our data. As such, we possibly overestimated the agreement and precision of these tests. The increased variability may have also increased the possibility of committing type two error in Chapter six.

Finally, care must be taken when generalizing findings from this research. For instance, the findings have limited generalizability to other participant types as the majority of the recruited sample involved uninjured athletes (85%), male athletes (63%), and athletes who played hockey, ringette, basketball, or soccer (60%). It is also important to consider that the examiners who collected data in this research were physiotherapists that had more than five years of experience in

SRC management. Hence, the findings may not be representative of the scores recorded by beginner physiotherapists or physiotherapists with limited experience in SRC management. Finally, generalizability to other environments (e.g., the field of play) and testing conditions (e.g., shoes off) should be done with caution as participants were tested in a physiotherapy clinic and a university laboratory with their shoe on.[23]

7.6 CLINICAL PRACTICE

This research has implications to clinical practice. The literature supports a change in practice where clinicians may extend the assessment of postural control following an SRC beyond single task-testing to include dual-task and sport-specific testing paradigms. This may help to identify subtle postural control deficits that may be missed using single-task testing paradigms and, consequently, individuals that are potentially at risk for future injury following an SRC.

While the FAB-C extends the assessment of postural control following an SRC beyond single task-testing to include dual-task and sport-specific testing paradigms, its administration time is lengthy [44-60 minutes]. The FAB-C administration time can be minimized by using it as a continuous postural control testing protocol that is spread out over the duration of an athlete's SRC recovery. For instance, the single-task testing paradigm could be used during the initial 24-48 hours following an SRC when its sensitivity to identify postural control impairments is high.[1] The dual-task testing paradigm, on the other hand, could then be used during the RTP progression (stage four of the graduated return-to-sport strategy) [1] because it reflects the brain's ability to integrate cognitive and motor information. This may be more reflective of sport participation than completing single-task postural control and cognitive assessments separately.[19] Finally, as the

sport-specific testing paradigm is more representative of the demands of actual sport than both the single- and dual-task testing paradigms, it can be used before returning an injured athlete to full-contact practice (stage five of the graduated return-to-sport strategy).[1, 4]

7.7 FUTURE DIRECTIONS

The investigations included in this dissertation contribute to the growing body of evidence examining postural control recovery status following SRC. These investigations highlight issues related to the quality (e.g., operationalizing outcome variables, employing prospective research designs, utilizing valid and reliable measures, and conducting appropriate statistical analyses) and level of evidence of postural control assessment in SRC. They also provide suggestions for addressing current limitations, such as a lack of inclusion of more challenging postural control environments that also consider cognitive and sport specific tasks, which will facilitate the evolution of the field. Considered in combination, the investigations undertaken in this doctoral research provide a foundation for future investigations aiming at understanding postural control impairments that stem from SRC. Logical progressions for future research are presented below.

7.7.1 Reliability and validity

An understanding of clinimetric properties (reliability and validity) of clinical assessments of postural control informs the effectiveness of postural control examination in SRC. Reliability means the ability of a measure to provide reproducible scores. Validity, on the other hand, refers to the tool's ability to measure what it is supposed to measure.[23]

At this point, there is a need for studies examining the effect of different sources of error (e.g., participant types, examiners, and environments) within the Balance Error Scoring System, Tandem Gait Test, and Clinical Reaction Time Tests (single- and dual-task); and Sport-Related Postural Control Test. Findings will inform future studies examining the reliability of the aforementioned clinical tests. These studies should recruit representative (i.e., large, age-specific, and concussed) athletic samples, use statistical analysis methods that account for the various sources of error within the evaluated clinical tests (e.g., generalizability theory analysis), and report findings according to an accepted reporting guideline for studies on the measurement properties of performance-based outcome measures [e.g., COnsensus-based Standards for the selection of health status Measurement INstruments (COSMIN)][28] to enhance comparability of studies.

In this dissertation, we demonstrated the reliability of different test items included in the FAB-C as well as the FAB-C's preliminary construct validity. Further clinimetric testing is warranted to establish its construct and concurrent validity, sensitivity and specificity, and ability to direct effective treatment for people with postural control impairments following SRC.

7.7.2 Postural control recovery pattern following sport-related concussion

At present, it is challenging to establish the time for recovery of postural control following SRC. This is mainly due to a paucity of high-quality studies using outcome measures with established clinimetric properties examining recovery across different systems that underlie postural control and are potentially affected by SRC. It is recommended that future studies should: (1) employ a prospective study design; (2) define impaired postural control associated with SRC as a multifaceted construct involving deficits in movement strategies, control of dynamics, sensory

strategies, cognitive contributions (i.e., dual-tasking), and orientation in space underlying systems of postural control; (3) recruit appropriately powered and representative samples (e.g., random sampling); (4) evaluate all underlying systems of postural control using outcome measures with established clinimetric properties; (5) examine postural control recovery status within the first 10 days after SRC and at the time of symptom resolution, the start of a gradual activity, and full clearance to RTP and beyond; and (6) report findings according to an accepted reporting guideline for observational studies [e.g., STrengthening the Reporting of OBservational studies in Epidemiology (STROBE)].[29]

7.7.3 Further development of the FAB-C

This dissertation presents the early stages of the FAB-C development. Further development of the FAB-C should include the addition of: (1) clinical tests that examine the potentially affected ‘orientation in space’ [30] and ‘biomechanical elements (i.e., cervical spine)’ [31] components of postural control, and (2) scoring procedures to capture the accuracy of cognitive responses which may be valuable for postural control assessment following an SRC. This would enhance the comprehensiveness of the FAB-C. Further development of the FAB-C may also include the development and assessment of the clinimetric properties of a briefer version of the FAB-C that still captures the most relevant information from the full battery. This may minimize the FAB-C’s administration time and, consequently, enhance its usability.

7.8 KNOWLEDGE TRANSLATION

This dissertation used an End of Grant approach to knowledge translation. In this approach, the researcher develops a plan for making knowledge users aware of the knowledge gained during a

research project. Examples of typical knowledge dissemination and communication activities included in the End of Grant approach to knowledge translation are conference presentations, publications in peer-reviewed journals, and or media engagement.[32] Knowledge translation activities in this doctoral research included:

- **Peer-reviewed journals:** Studies presented in chapters two and three of this dissertation have been published in the Clinical Journal of Sport Medicine and the Journal of Physiotherapy Theory and Practice, respectively. The study presented in chapter four has been accepted for publication in The International Journal of Sports Physical Therapy.
- **Presentations:** Studies in chapters two and three have been presented in the Rehabilitation Research Day at the Faculty of Rehabilitation Medicine – University of Alberta. The main findings from this dissertation were presented to a group of 15 sport physical therapists during a learning session that was organized by Sport Physiotherapy Canada in 2020.
- **Media engagement:** In 2018, Physiotherapy Alberta College + Association invited our team to write a Research in Focus article to provide a lay summary of our project for physiotherapists and the general population in Alberta. There was also a media event that covered our project in the same year.

Future dissemination and communication activities may include conference presentations, summary briefings to stakeholders, interactive educational sessions with patients, practitioners and/or policymakers.[32]

7.9 CONCLUSIONS

The FAB-C is a novel clinical assessment tool that aims to target different components of postural control that may be affected following SRC (i.e., sensory integration, control of dynamics, and movement strategies) under single-task, dual-task, and sport-specific testing paradigms. Three clinical tests (Balance Error Scoring System, Tandem Gait Test, and Clinical Reaction Time) assessed under single- and dual-task conditions, and a fourth fit-for-purpose Sport-Related Postural Control Test were included in the FAB-C. Overall, these tests have demonstrated acceptable relative and absolute intra-rater and inter-rater reliability in uninjured active youth and young adults. While the FAB-C has demonstrated feasibility and preliminary construct validity, it requires further evaluation before widespread use in clinical settings.

7.10 REFERENCES

1. McCrory P, Meeuwisse W, Dvorak J, Aubry M, Bailes J, Broglio S, et al. Consensus statement on concussion in sport-the 5(th) International Conference on Concussion in Sport held in Berlin, October 2016. *Br J Sports Med.* 2017;51(11):838-47.
2. Buttner F, Howell DR, Ardern CL, Doherty C, Blake C, Ryan J, et al. Concussed athletes walk slower than non-concussed athletes during cognitive-motor dual-task assessments but not during single-task assessments 2 months after sports concussion: a systematic review and meta-analysis using individual participant data. *Br J Sports Med.* 2019:bjsports-2018-100164.
3. Wood TA, Hsieh KL, An R, Ballard RA, Sosnoff JJ. Balance and gait alterations observed more than 2 weeks after concussion: a systematic review and meta-analysis. *Am J Phys Med Rehabil.* 2019;98(7):566-76.
4. Grants L, Powell B, Gessel C, Hiser F, Hassen A. Gait deficits under dual-task conditions in the concussed adolescent and young athlete population: a systematic review. *Int J Sports Phys Ther.* 2017;12(7):1011.
5. Manaseer TS, Gross DP, Dennett L, Schneider K, Whittaker JL. Gait deviations associated with concussion: A Systematic Review [published online ahead of print, 2017 Nov 21]. *Clin J Sport Med.* 2017;10.1097/JSM.0000000000000537. doi:10.1097/JSM.0000000000000537.
6. Horak FB. Postural orientation and equilibrium: what do we need to know about neural control of balance to prevent falls? *Age Ageing.* 2006;35 Suppl 2(SUPPL.2):ii7-ii11.

7. Guskiewicz KM. Balance assessment in the management of sport-related concussion. *Clin Sports Med.* 2011;30(1):89-102, ix.
8. Gillen G. *Stroke rehabilitation: a function-based approach.* 4th ed. St. Louis, MO: Elsevier Health Sciences; 2016.
9. Murray NG, Reed-Jones RJ, Szekely BJ, Powell DW. Clinical assessments of balance in adults with concussion: an update. *Semin Speech Lang.* 2019;40(01):048-56.
10. Buckley TA, Oldham JR, Caccese JB. Postural control deficits identify lingering post-concussion neurological deficits. *Sport Sci Health.* 2016;5(1):61-9.
11. Echemendia RJ, Meeuwisse W, McCrory P, Davis GA, Putukian M, Leddy J, et al. The Sport Concussion Assessment Tool 5th Edition (SCAT5): background and rationale. *Br J Sports Med.* 2017;51(11):848-50.
12. Howell DR, Kirkwood MW, Provance A, Iverson GL, Meehan III WP. Using concurrent gait and cognitive assessments to identify impairments after concussion: a narrative review. *Concussion.* 2018;3(1):CNC54.
13. Eckner JT, Richardson JK, Kim H, Joshi MS, Oh YK, Ashton-Miller JA. Reliability and criterion validity of a novel clinical test of simple and complex reaction time in athletes. *Percept Mot Skills.* 2015;120(3):841-59.

14. Manaseer TS, Gross DP, Mrazik M, Schneider K, Whittaker JL. Re-conceptualizing postural control assessment in sport-related concussion: Transitioning from the reflex/hierarchical model to the systems model. *Physiother Theory Pract.* 2019;1-12.
15. Ross LM, Register-Mihalik JK, Mihalik JP, McCulloch KL, Prentice WE, Shields EW, et al. Effects of a single-task versus a dual-task paradigm on cognition and balance in healthy subjects. *J Sport Rehabil.* 2011;20(3):296-310.
16. Howell DR, Brilliant AN, Meehan III WP. Tandem Gait test-retest reliability among healthy child and adolescent athletes. *J Athl Train.* 2019;54(12):1254-9.
17. Eckner JT, Kutcher JS, Richardson JK. Between-seasons test-retest reliability of clinically measured reaction time in National Collegiate Athletic Association Division I athletes. *J Athl Train.* 2011;46(4):409-14.
18. Register-Mihalik JK, Littleton AC, Guskiewicz KM. Are divided attention tasks useful in the assessment and management of sport-related concussion? *Neuropsychol Rev.* 2013;23(4):300-13.
19. Howell DR, Lynall RC, Buckley TA, Herman DC. Neuromuscular control deficits and the risk of subsequent injury after a concussion: a scoping Review. *Sports Med.* 2018;48(5):1097-115.
20. DuBose DF, Herman DC, Jones DL, Tillman SM, Clugston JR, Pass A, et al. Lower extremity stiffness changes following concussion in collegiate football players. *Med Sci Sports Exerc.* 2017;49(1):167.

21. Alsalaheen BA, Mucha A, Morris LO, Whitney SL, Furman JM, Camiolo-Reddy CE, et al. Vestibular rehabilitation for dizziness and balance disorders after concussion. *J Neurol Phys Ther.* 2010;34(2):87-93.
22. Council NR, Youth CoS-RCi. Sports-related concussions in youth: improving the science, changing the culture: National Academies Press; 2014.
23. Portney LG, Watkins MP. Foundations of clinical research: applications to practice: Pearson/Prentice Hall Upper Saddle River, NJ; 2009.
24. Peat J. Health science research: A handbook of quantitative methods. London: Sage; 2001.
25. Pourhoseingholi MA, Baghestani AR, Vahedi M. How to control confounding effects by statistical analysis. *Gastroenterol Hepatol Bed Bench.* 2012;5(2):79.
26. Sarto F, Grigoletto D, Baggio E, Paoli A, Marcolin G. Do lower limb previous injuries affect balance performance? An observational study in volleyball players. *Phys Ther Sport.* 2019;37:49-53.
27. Johnston W, Heiderscheit B, Sanfilippo J, Brooks MA, Caulfield B. Athletes with a concussion history in the last two years have impairments in dynamic balance performance. *Scand J Med Sci Sports.* 2020.
28. Mokkink LB, Terwee CB, Patrick DL, Alonso J, Stratford PW, Knol DL, et al. The COSMIN checklist for assessing the methodological quality of studies on measurement properties of health status measurement instruments: an international Delphi study. *Qual Life Res.* 2010;19(4):539-49.

29. Vandenberg JP, Von Elm E, Altman DG, Gøtzsche PC, Mulrow CD, Pocock SJ, et al. Strengthening the Reporting of Observational Studies in Epidemiology (STROBE): explanation and elaboration. *Ann Intern Med.* 2007;147(8):W-163-W-94.
30. Guskiewicz KM, Ross SE, Marshall SW. Postural stability and neuropsychological deficits after concussion in collegiate athletes. *J Athl Train.* 2001;36(3):263-73.
31. Cheever K, Kawata K, Tierney R, Galgon A. Cervical injury assessments for concussion evaluation: a review. *J Athl Train.* 2016;51(12):1037-44.
32. Government of Canada, Canadian Institutes of Health Research, Institute Affairs. End of Grant knowledge translation [Internet]. CIHR. Canadian Institutes of Health Research; 2016 [cited 2020Mar30]. Available from: <https://cihr-irsc.gc.ca/e/29418.html#5.1>

References

1. Statistics Canada. Table 13-10-0096-01 Health characteristics, annual estimates. DOI: <https://doi.org/10.25318/1310009601-eng>
2. Organization WH. Global recommendations on physical activity for health. Switzerland: Geneva;2010. Available from: <https://www.who.int/dietphysicalactivity/global-PA-recs-2010.pdf> [Accessed 22nd June 2019].
3. Sheu Y, Chen LH, Hedegaard H. Sports- and Recreation-related Injury Episodes in the United States, 2011-2014. *Natl Health Stat Report*. 2016;(99):1-12.
4. King MA, Pickett W, King AJ. Injury in Canadian youth: A secondary analysis of the 1993-94 health behaviour in school-aged children survey. *Can J Public Health*. 1998;89(6):397-401.
5. Canada Go. Concussion in sport 2016 [updated May 02, 2018; cited 2018 September 24]. Available from: <https://www.canada.ca/en/canadian-heritage/services/concussions.html>.
6. Emery C, Tyreman H. Sport participation, sport injury, risk factors and sport safety practices in Calgary and area junior high schools. *Paediatr Child Health*. 2009;14(7):439-44.
7. Emery CA, Meeuwisse WH, McAllister JR. Survey of sport participation and sport injury in Calgary and area high schools. *Clin J Sport Med*. 2006;16(1):20-6.

8. McCrory P, Meeuwisse W, Dvorak J, Aubry M, Bailes J, Broglio S, et al. Consensus statement on concussion in sport-the 5(th) International Conference on Concussion in Sport held in Berlin, October 2016. *Br J Sports Med.* 2017;51(11):838-47.
9. Guskiewicz KM, Marshall SW, Bailes J, McCrea M, Cantu RC, Randolph C, et al. Association between recurrent concussion and late-life cognitive impairment in retired professional football players. *Neurosurgery.* 2005;57(4):719-26.
10. Pan T, Liao K, Roenigk K, Daly JJ, Walker MF. Static and dynamic postural stability in veterans with combat-related mild traumatic brain injury. *Gait Posture.* 2015;42(4):550-7.
11. Emery CA, Black AM, Kolstad A, Martinez G, Nettel-Aguirre A, Engebretsen L, et al. What strategies can be used to effectively reduce the risk of concussion in sport? *Br J Sports Med.* 2017:bjsports-2016-097452.
12. Echemendia RJ, Meeuwisse W, McCrory P, Davis GA, Putukian M, Leddy J, et al. The Sport Concussion Assessment Tool 5th Edition (SCAT5): background and rationale. *Br J Sports Med.* 2017;51(11):848-50.
13. Guskiewicz KM. Balance assessment in the management of sport-related concussion. *Clin Sports Med.* 2011;30(1):89-102, ix.
14. Johnston W, Coughlan GF, Caulfield B. Challenging concussed athletes: the future of balance assessment in concussion. *QJM.* 2016;110(12):779-83.

15. Shumway-Cook A, Woollacott MH. Motor control: translating research into clinical practice. 3rd ed. Philadelphia: Lippincott Williams & Wilkins; 2007.
16. Lundy-Ekman L. Neuroscience: fundamentals for rehabilitation 4th ed. St. Louis, MO: Elsevier Health Sciences; 2013.
17. Sabin MJ. Reliability and validity of the Condition-Modified Star Excursion Balance Test: Influence of concussion history[dissertation]. University of Illinois; 2011.
18. Horak FB. Postural orientation and equilibrium: what do we need to know about neural control of balance to prevent falls? *Age Ageing*. 2006;35 Suppl 2(SUPPL.2):ii7-ii11.
19. Powers KC, Kalmar JM, Cinelli ME. Recovery of static stability following a concussion. *Gait Posture*. 2014;39(1):611-4.
20. Howell DR, Osternig LR, Chou LS. Adolescents demonstrate greater gait balance control deficits after concussion than young adults. *Am J Sports Med*. 2015;43(3):625-32.
21. Shaw NA. The neurophysiology of concussion. *Prog Neurobiol*. 2002;67(4):281-344.
22. Catena RD, van Donkelaar P, Chou L-S. Altered balance control following concussion is better detected with an attention test during gait. *Gait Posture*. 2007;25(3):406-11.
23. Barr WB, Prichep LS, Chabot R, Powell MR, McCrea M. Measuring brain electrical activity to track recovery from sport-related concussion. *Brain Inj*. 2012;26(1):58-66.

24. Schneider KJ. Concussion-Part I: The need for a multifaceted assessment. *Musculoskelet Sci Pract.* 2019;42:140-50.
25. McDevitt J, Appiah-Kubi K, Tierney R, Wright W. Vestibular and oculomotor assessments may increase accuracy of subacute concussion assessment. *Int J Sports Med.* 2016;37(09):738-47.
26. McCrory P, Meeuwisse WH, Aubry M, Cantu RC, Dvorak J, Echemendia RJ, et al. Consensus statement on concussion in sport--the 4th International Conference on Concussion in Sport held in Zurich, November 2012. *PM R.* 2013;5(4):255-79.
27. Howell DR, Osternig LR, Chou LS. Single-task and dual-task tandem gait test performance after concussion. *J Sci Med Sport.* 2017;20(7):622-6.
28. Galetta KM, Morganroth J, Moehringer N, Mueller B, Hasanaj L, Webb N, et al. Adding vision to concussion testing: a prospective study of sideline testing in youth and collegiate athletes. *J Neuroophthalmol.* 2015;35(3):235-41.
29. Santo A, Lynall RC, Guskiewicz KM, Mihalik JP. Clinical utility of the Sport Concussion Assessment Tool 3 (SCAT3) Tandem-Gait Test in high school athletes. *J Athl Train.* 2017;52(12):1096-100.
30. Schneiders AG, Sullivan SJ, Kvarnstrom J, Olsson M, Yden T, Marshall S. The effect of footwear and sports-surface on dynamic neurological screening for sport-related concussion. *J Sci Med Sport.* 2010;13(4):382-6.

31. Schneiders AG, Sullivan SJ, Gray AR, Hammond-Tooke GD, McCrory PR. Normative values for three clinical measures of motor performance used in the neurological assessment of sports concussion. *J Sci Med Sport*. 2010;13(2):196-201.
32. Schneiders AG, Sullivan SJ, McCrory PR, Gray AR, Maruthayanar S, Singh P, et al. The effect of exercise on motor performance tasks used in the neurological assessment of sports related concussion. *Br J Sports Med*. 2008;42(12):1011-3.
33. Onate JA, Beck BC, Van Lunen BL. On-field testing environment and Balance Error Scoring System performance during preseason screening of healthy collegiate baseball players. *J Athl Train*. 2007;42(4):446-51.
34. Ozinga SJ, Linder SM, Koop MM, Dey T, Figler R, Russman AN, et al. Normative performance on the Balance Error Scoring System by youth, high school, and collegiate athletes. *J Athl Train*. 2018;53(7):636-45.
35. McCrea M, Guskiewicz K, Randolph C, Barr WB, Hammeke TA, Marshall SW, et al. Incidence, clinical course, and predictors of prolonged recovery time following sport-related concussion in high school and college athletes. *J Int Neuropsychol Soc*. 2013;19(1):22-33.
36. McCrea M, Guskiewicz KM, Marshall SW, Barr W, Randolph C, Cantu RC, et al. Acute effects and recovery time following concussion in collegiate football players: the NCAA Concussion Study. *JAMA*. 2003;290(19):2556-63.

- 37.Riemann BL, Guskiewicz KM. Effects of mild head injury on postural stability as measured through clinical balance testing. *J Athl Train.* 2000;35(1):19-25.
- 38.Guskiewicz KM, Ross SE, Marshall SW. Postural stability and neuropsychological deficits after concussion in collegiate athletes. *J Athl Train.* 2001;36(3):263-73.
- 39.Riemann BL, Guskiewicz KM, Shields EW. Relationship between clinical and forceplate measures of postural stability. *J Sport Rehabil.* 1999;8(2):71-82.
- 40.Bell DR, Guskiewicz KM, Clark MA, Padua DA. Systematic review of the Balance Error Scoring System. *Sports Health.* 2011;3(3):287-95.
- 41.Hunt TN, Ferrara MS, Bornstein RA, Baumgartner TA. The reliability of the modified Balance Error Scoring System. *Clin J Sport Med.* 2009;19(6):471-5.
- 42.Erkmen N, Taşkın H, Kaplan T, Sanioglu A. The effect of fatiguing exercise on balance performance as measured by the balance error scoring system. *Isokinet Exerc Sci.* 2009;17(2):121-7.
- 43.McLeod TC, Armstrong T, Miller M, Sauers JL. Balance improvements in female high school basketball players after a 6-week neuromuscular-training program. *J Sport Rehabil.* 2009;18(4):465-81.
- 44.McLeod TCV, Barr WB, McCrea M, Guskiewicz KM. Psychometric and measurement properties of concussion assessment tools in youth sports. *J Athl Train.* 2006;41(4):399.

45. McLeod TCV, Perrin DH, Guskiewicz KM, Shultz SJ, Diamond R, Gansneder BM. Serial administration of clinical concussion assessments and learning effects in healthy young athletes. *Clin J Sport Med.* 2004;14(5):287-95.
46. Susco TM, McLeod TCV, Gansneder BM, Shultz SJ. Balance recovers within 20 minutes after exertion as measured by the Balance Error Scoring System. *J Athl Train.* 2004;39(3):241.
47. Finnoff JT, Peterson VJ, Hollman JH, Smith J. Intrarater and interrater reliability of the Balance Error Scoring System (BESS). *PM R.* 2009;1(1):50-4.
48. Cushman D, Hendrick J, Teramoto M, Fogg B, Bradley S, Hansen C. Reliability of the balance error scoring system in a population with protracted recovery from mild traumatic brain injury. *Brain Inj.* 2018;32(5):569-74.
49. Murray N, Salvatore A, Powell D, Reed-Jones R. Reliability and validity evidence of multiple balance assessments in athletes with a concussion. *J Athl Train.* 2014;49(4):540-9.
50. Iverson GL, Koehle MS. Normative data for the modified balance error scoring system in adults. *Brain Inj.* 2013;27(5):596-9.
51. Snedden TR, Brooks MA, Hetzel S, McGuine T. Normative values of the Sport Concussion Assessment Tool 3 (SCAT3) in high school athletes. *Clin J Sport Med.* 2017;27(5):462-7.

52. Hansen C, Cushman D, Anderson N, Chen W, Cheng C, Hon SD, et al. A normative dataset of the balance error scoring system in children aged between 5 and 14. *Clin J Sport Med.* 2016;26(6):497-501.
53. Chin EY, Nelson LD, Barr WB, McCrory P, McCrea MA. Reliability and validity of the Sport Concussion Assessment Tool–3 (SCAT3) in high school and collegiate athletes. *Am J Sports Med.* 2016;44(9):2276-85.
54. Putukian M, Echemendia R, Dettwiler-Danspeckgruber A, Duliba T, Bruce J, Furtado JL, et al. Prospective clinical assessment using Sideline Concussion Assessment Tool-2 testing in the evaluation of sport-related concussion in college athletes. *Clin J Sport Med.* 2015;25(1):36-42.
55. King LA, Horak FB, Mancini M, Pierce D, Priest KC, Chesnutt J, et al. Instrumenting the balance error scoring system for use with patients reporting persistent balance problems after mild traumatic brain injury. *Arch Phys Med Rehabil.* 2014;95(2):353-9.
56. Kleffelgaard I, Langhammer B, Sandhaug M, Pripp AH, Sørberg HL. Measurement properties of the modified and total Balance Error Scoring System—the BESS, in a healthy adult sample. *Eur J Physiother.* 2018;20(1):25-31.
57. Wilkins JC, Valovich McLeod TC, Perrin DH, Gansneder BM. Performance on the Balance Error Scoring System decreases after fatigue. *J Athl Train.* 2004;39(2):156-61.

58. Buckley TA, Munkasy BA, Clouse BP. Sensitivity and specificity of the modified Balance Error Scoring System in concussed collegiate student athletes. *Clin J Sport Med.* 2018;28(2):174-6.
59. Cross M, Kemp S, Smith A, Trewartha G, Stokes K. Professional Rugby Union players have a 60% greater risk of time loss injury after concussion: a 2-season prospective study of clinical outcomes. *Br J Sports Med.* 2016;50(15):926-31.
60. Lynall RC, Mauntel TC, Padua DA, Mihalik JP. Acute lower extremity injury rates increase after concussion in college athletes. *Med Sci Sports Exerc.* 2015;47(12):2487-92.
61. Nordstrom A, Nordstrom P, Ekstrand J. Sports-related concussion increases the risk of subsequent injury by about 50% in elite male football players. *Br J Sports Med.* 2014;48(19):1447-50.
62. Pietrosimone B, Golightly YM, Mihalik JP, Guskiewicz KM. Concussion frequency associates with musculoskeletal injury in retired NFL players. *Med Sci Sports Exerc.* 2015;47(11):2366-72.
63. Makdissi M, McCrory P, Ugoni A, Darby D, Brukner P. A prospective study of postconcussive outcomes after return to play in Australian football. *Am J Sports Med.* 2009;37(5):877-83.
64. Brooks MA, Peterson K, Biese K, Sanfilippo J, Heiderscheit BC, Bell DR. Concussion increases odds of sustaining a lower extremity musculoskeletal injury after return to play among collegiate athletes. *Am J Sports Med.* 2016;44(3):742-7.

65. Burman E, Lysholm J, Shahim P, Malm C, Tegner Y. Concussed athletes are more prone to injury both before and after their index concussion: a data base analysis of 699 concussed contact sports athletes. *BMJ Open Sport Exerc Med.* 2016;2(1):e000092.
66. Hägglund M, Waldén M, Ekstrand J. Previous injury as a risk factor for injury in elite football: a prospective study over two consecutive seasons. *Br J Sports Med.* 2006;40(9):767-72.
67. Herman DC, Jones D, Harrison A, Moser M, Tillman S, Farmer K, et al. Concussion may increase the risk of subsequent lower extremity musculoskeletal injury in collegiate athletes. *Sports Med.* 2017;47(5):1003-10.
68. Gilbert FC, Burdette GT, Joyner AB, Llewellyn TA, Buckley TA. Association between concussion and lower extremity injuries in collegiate athletes. *Sports Health.* 2016;8(6):561-7.
69. Howell DR, Lynall RC, Buckley TA, Herman DC. Neuromuscular control deficits and the risk of subsequent injury after a concussion: a scoping review. *Sports Med.* 2018;48(5):1097-115.
70. McPherson AL, Nagai T, Webster KE, Hewett TE. Musculoskeletal injury risk after sport-related concussion: a systematic review and meta-analysis. *Am J Sports Med.* 2018;47(7):1754-62.
71. Emery C, Kang J, Shrier I, Goulet C, Hagel B, Benson B, et al. Risk of injury associated with bodychecking experience among youth hockey players. *CMAJ.* 2011;183(11):1249-56.

72. Emery CA, Kang J, Shrier I, Goulet C, Hagel BE, Benson BW, et al. Risk of injury associated with body checking among youth ice hockey players. *JAMA*. 2010;303(22):2265-72.

73. Emery CA, Kang J, Schneider KJ, Meeuwisse WH. Risk of injury and concussion associated with team performance and penalty minutes in competitive youth ice hockey. *Br J Sports Med*. 2011;45(16):1289-93.

74. Zemper ED. Two-year prospective study of relative risk of a second cerebral concussion. *Am J Phys Med Rehabil*. 2003;82(9):653-9.

75. Guskiewicz KM, McCrea M, Marshall SW, Cantu RC, Randolph C, Barr W, et al. Cumulative effects associated with recurrent concussion in collegiate football players: the NCAA Concussion Study. *JAMA*. 2003;290(19):2549-55.

76. Hollis SJ, Stevenson MR, McIntosh AS, Shores EA, Collins MW, Taylor CB. Incidence, risk, and protective factors of mild traumatic brain injury in a cohort of Australian nonprofessional male rugby players. *Am J Sports Med*. 2009;37(12):2328-33.

77. Schneider KJ, Meeuwisse WH, Kang J, Schneider GM, Emery CA. Preseason reports of neck pain, dizziness, and headache as risk factors for concussion in male youth ice hockey players. *Clin J Sport Med*. 2013;23(4):267-72.

77. Schneider KJ, Meeuwisse WH, Kang J, Schneider GM, Emery CA. Preseason reports of neck pain, dizziness, and headache as risk factors for concussion in male youth ice hockey players. *Clin J Sport Med*. 2013;23(4):267-72.

78.Slobounov SM, Sebastianelli WJ, editors. Foundations of sport-related brain injuries. New York: Springer Science & Business Media; 2006. Chapter 2: Aerobic fitness and concussion outcomes in high school football;p. 315-39.

79.Abrahams S, Fie SM, Patricios J, Posthumus M, September AV. Risk factors for sports concussion: an evidence-based systematic review. Br J Sports Med. 2014;48(2):91-7.

80.Tremblay S, de Beaumont L, Lassonde M, Theoret H. Evidence for the specificity of intracortical inhibitory dysfunction in asymptomatic concussed athletes. J Neurotrauma. 2011;28(4):493-502.

81.Marshall S, Bayley M, McCullagh S, Velikonja D, Berrigan L. Clinical practice guidelines for mild traumatic brain injury and persistent symptoms. Can Fam Physician. 2012;58(3):257-67, e128-40.

82.Cassidy JD, Carroll LJ, Peloso PM, Borg J, von Holst H, Holm L, et al. Incidence, risk factors and prevention of mild traumatic brain injury: results of the WHO Collaborating Centre Task Force on Mild Traumatic Brain Injury. J Rehabil Med. 2004;36(43 Suppl):28-60.

83.De Beaumont L, Mongeon D, Tremblay S, Messier J, Prince F, Leclerc S, et al. Persistent motor system abnormalities in formerly concussed athletes. J Athl Train. 2011;46(3):234-40.

84. Ruff RM, Iverson GL, Barth JT, Bush SS, Broshek DK, Policy NAN, et al. Recommendations for diagnosing a mild traumatic brain injury: a National Academy of Neuropsychology education paper. *Arch Clin Neuropsychol*. 2009;24(1):3-10.
85. Broglio SP, Cantu RC, Gioia GA, Guskiewicz KM, Kutcher J, Palm M, et al. National Athletic Trainers' Association position statement: management of sport concussion. *J Athl Train*. 2014;49(2):245-65.
86. Kharb A, Saini V, Jain Y, Dhiman S. A review of gait cycle and its parameters. *IJCEM*. 2011;13:78-83.
87. Muro-de-la-Herran A, Garcia-Zapirain B, Mendez-Zorrilla A. Gait analysis methods: an overview of wearable and non-wearable systems, highlighting clinical applications. *Sensors*. 2014;14(2):3362-94.
88. Catena RD. Attention and gait performance following a concussion [dissertation]. University of Oregon; 2008.
89. Fino PC. A preliminary study of longitudinal differences in local dynamic stability between recently concussed and healthy athletes during single and dual-task gait. *J Biomech*. 2016;49(9):1983-8.
90. Howell D, Osternig L, Chou LS. Monitoring recovery of gait balance control following concussion using an accelerometer. *J Biomech*. 2015;48(12):3364-8.

91. Liberati A, Altman DG, Tetzlaff J, Mulrow C, Gøtzsche PC, Ioannidis JPA, et al. The PRISMA statement for reporting systematic reviews and meta-analyses of studies that evaluate health care interventions: explanation and elaboration. *J Clin Epidemiol*. 2009;62:e1-34.
92. Jennett B. Development of Glasgow coma and outcome scales. *Nepal Journal of Neuroscience*. 2005;2(1):24-8.
93. VonVille HM. Excel workbooks for systematic reviews [internet]. Texas: The University of Texas; 2015 [Accessed January 1, 2016]. Available from: http://libguides.sph.uth.tmc.edu/excel_workbook_home.
94. Downs SH, Black N. The feasibility of creating a checklist for the assessment of the methodological quality both of randomised and non-randomised studies of health care interventions. *J Epidemiol Community Health*. 1998;52(6):377-84.
95. Howick J, Phillips B, Ball C, et al. Oxford centre for evidence-based medicine: Levels of evidence 2009. Oxford Centre for Evidence-Based Medicine; 2009 [Accessed January 3, 2016]. Available at: <http://www.cebm.net/oxford-centre-evidence-based-medicine-levels-evidence-march-2009/>.
96. Howell DR, Beasley M, Vopat L, Meehan WP, 3rd. The effect of prior concussion history on dual-task gait following a concussion. *J Neurotrauma*. 2017;34(4):838-44.
97. Howell DR, Osternig LR, Christie AD, Chou L-S. Return to physical activity timing and dual-task gait stability are associated 2 months following concussion. *J Head Trauma Rehabil*. 2015.

98. Howell DR, Osternig LR, Chou LS. Return to activity after concussion affects dual-task gait balance control recovery. *Med Sci Sports Exerc.* 2015;47(4):673-80.
99. Howell DR, Osternig LR, Koester MC, Chou LS. The effect of cognitive task complexity on gait stability in adolescents following concussion. *Exp Brain Res.* 2014;232(6):1773-82.
100. Powers KC, Kalmar JM, Cinelli ME. Dynamic stability and steering control following a sport-induced concussion. *Gait Posture.* 2014;39(2):728-32.
101. Buckley TA, Munkasy BA, Tapia-Lovler TG, Wikstrom EA. Altered gait termination strategies following a concussion. *Gait Posture.* 2013;38(3):549-51.
102. Chiu SL, Osternig L, Chou LS. Concussion induces gait inter-joint coordination variability under conditions of divided attention and obstacle crossing. *Gait Posture.* 2013;38(4):717-22.
103. Howell DR, Osternig LR, Chou LS. Dual-task effect on gait balance control in adolescents with concussion. *Arch Phys Med Rehabil.* 2013;94(8):1513-20.
104. Kleffelgaard I, Roe C, Soberg HL, Bergland A. Associations among self-reported balance problems, post-concussion symptoms and performance-based tests: a longitudinal follow-up study. *Disabil Rehabil.* 2012;34(9):788-94.
105. Catena RD, van Donkelaar P, Chou LS. The effects of attention capacity on dynamic balance control following concussion. *J Neuroeng Rehabil.* 2011;8:8.

106. Catena RD, van Donkelaar P, Chou LS. Different gait tasks distinguish immediate vs. long-term effects of concussion on balance control. *J Neuroeng Rehabil.* 2009;6:25.
107. Catena RD, van Donkelaar P, Halterman CI, Chou LS. Spatial orientation of attention and obstacle avoidance following concussion. *Exp Brain Res.* 2009;194(1):67-77.
108. Parker TM, Osternig LR, van Donkelaar P, Chou LS. Balance control during gait in athletes and non-athletes following concussion. *Med Eng Phys.* 2008;30(8):959-67.
109. Catena RD, van Donkelaar P, Chou LS. Cognitive task effects on gait stability following concussion. *Exp Brain Res.* 2007;176(1):23-31.
110. Parker TM, Osternig LR, van Donkelaar P, Chou LS. Recovery of cognitive and dynamic motor function following concussion. *Br J Sports Med.* 2007;41(12):868-73; discussion 73.
111. Parker TM, Osternig LR, P VAND, Chou LS. Gait stability following concussion. *Med Sci Sports Exerc.* 2006;38(6):1032-40.
112. Parker TM, Osternig LR, Lee HJ, Donkelaar P, Chou LS. The effect of divided attention on gait stability following concussion. *Clin Biomech (Bristol, Avon).* 2005;20(4):389-95.
113. Button KS, Ioannidis JP, Mokrysz C, Nosek BA, Flint J, Robinson ES, et al. Power failure: why small sample size undermines the reliability of neuroscience. *Nat Rev Neurosci.* 2013;14(5):365-76.

114. Lee H, Sullivan SJ, Schneiders AG. The use of the dual-task paradigm in detecting gait performance deficits following a sports-related concussion: a systematic review and meta-analysis. *J Sci Med Sport*. 2013;16(1):2-7.
115. Basford JR, Chou LS, Kaufman KR, Brey RH, Walker A, Malec JF, et al. An assessment of gait and balance deficits after traumatic brain injury. *Arch Phys Med Rehabil*. 2003;84(3):343-9.
116. Kaya BK, Krebs DE, Riley PO. Dynamic stability in elders: momentum control in locomotor ADL. *J Gerontol A Biol Sci Med Sci*. 1998;53(2):M126-34.
117. Schneiders A, Sullivan S, Lee H, McCrory P. An evaluation of Tandem Gait as a measure of dynamic balance and coordination in the assessment of individuals with medical diagnosed sports-related concussion. *J Sci Med Sport*. 2013;16(e88):e88.
118. Selassie AW, Wilson DA, Pickelsimer EE, Voronca DC, Williams NR, Edwards JC. Incidence of sport-related traumatic brain injury and risk factors of severity: a population-based epidemiologic study. *Ann Epidemiol*. 2013;23(12):750-6.
119. Zemek R, Barrowman N, Freedman SB, Gravel J, Gagnon I, McGahern C, et al. Clinical risk score for persistent postconcussion symptoms among children with acute concussion in the ED. *JAMA*. 2016;315(10):1014-25.
120. Hume PA, Theadom A, Lewis GN, Quarrie KL, Brown SR, Hill R, et al. A comparison of cognitive function in former Rugby Union players compared with former non-contact-sport players and the impact of concussion history. *Sports Med*. 2017;47(6):1209-20.

121. Murray NG, Reed-Jones RJ, Szekely BJ, Powell DW. Clinical assessments of balance in adults with concussion: an update. *Semin Speech Lang*. 2019;40(01):048-56.
122. Buckley TA, Oldham JR, Caccese JB. Postural control deficits identify lingering post-concussion neurological deficits. *Sport Sci Health*. 2016;5(1):61-9.
123. Slobounov SM, Sebastianelli WJ. *Concussions in athletics: from brain to behavior*. New York: Springer Science & Business Media; 2014.
124. Gillen G. *Stroke rehabilitation: a function-based approach*. 4th ed. St. Louis, MO: Elsevier Health Sciences; 2016.
125. Fay B Horak DMW, James Frank. The Balance Evaluation Systems Test (BESTest) to Differentiate Balance Deficits. *Phys Ther*. 2003;14(3):278-82.
126. Horak FB. Postural Control. *Encyclopedia of Neuroscience*. Berlin, Heidelberg: Springer Berlin Heidelberg; 2009.
127. Sibley KM, Beauchamp MK, Van Ooteghem K, Straus SE, Jaglal SB. Using the systems framework for postural control to analyze the components of balance evaluated in standardized balance measures: a scoping review. *Arch Phys Med Rehabil*. 2015;96(1):122-32 e29.
128. Broglio SP, Collins MW, Williams RM, Mucha A, Kontos AP. Current and emerging rehabilitation for concussion: a review of the evidence. *Clin Sports Med*. 2015;34(2):213-31.

- 129.Santos MJ, Kanekar N, Aruin AS. The role of anticipatory postural adjustments in compensatory control of posture: 2. Biomechanical analysis. *J Electromyogr Kinesiol.* 2010;20(3):398-405.
- 130.Mille M-L, Johnson ME, Martinez KM, Rogers MW. Age-dependent differences in lateral balance recovery through protective stepping. *Clin Biomech (Bristol, Avon).* 2005;20(6):607-16.
- 131.Buckley TA, Oldham JR, Munkasy BA, Evans KM. Decreased anticipatory postural adjustments during gait initiation acutely postconcussion. *Arch Phys Med Rehabil.* 2017;98(10):1962-8.
- 132.Dierijck JK. Multiple concussions and dual task paradigms: reactive postural perturbation management [dissertation]. University of British Columbia; 2017.
- 133.Eckner JT, Kutcher JS, Broglio SP, Richardson JK. Effect of sport-related concussion on clinically measured simple reaction time. *Br J Sports Med.* 2014;48(2):112-8.
- 134.Manaseer TS, Gross DP, Dennett L, Schneider K, Whittaker JL. Gait deviations associated with concussion: A Systematic Review [published online ahead of print, 2017 Nov 21]. *Clin J Sport Med.* 2017;10.1097/JSM.0000000000000537. doi:10.1097/JSM.000000000000053
- 135.Kontos AP, Deitrick JM, Collins MW, Mucha A. Review of vestibular and oculomotor screening and concussion rehabilitation. *J Athl Train.* 2017;52(3):256-61.

136. Peterka RJ. Sensorimotor integration in human postural control. *J Neurophysiol.* 2002;88(3):1097-1118.
137. Park J-H, Kang Y-J, Horak FB. What is wrong with balance in Parkinson's disease? *Mov Disord.* 2015;8(3):109.
138. Mallinson AI, Longridge NS. Dizziness from whiplash and head injury: differences between whiplash and head injury. *Otol Neurotol.* 1998;19(6):814-8.
139. Gera G, Chesnutt J, Mancini M, Horak FB, King LA. Inertial sensor-based assessment of central sensory integration for balance after mild traumatic brain injury. *Mil Med.* 2018;183(suppl_1):327-32.
140. Schmidt JD, Terry DP, Ko J, Newell KM, Miller LS. Balance regularity among former high school football players with or without a history of concussion. *J Athl Train.* 2018;53(2):109-14.
141. Sosnoff JJ, Broglio SP, Shin S, Ferrara MS. Previous mild traumatic brain injury and postural-control dynamics. *J Athl Train.* 2011;46(1):85-91.
142. Register-Mihalik JK, Littleton AC, Guskiewicz KM. Are divided attention tasks useful in the assessment and management of sport-related concussion? *Neuropsychol Rev.* 2013;23(4):300-13.
143. Rochefort C, Walters-Stewart C, Aglipay M, Barrowman N, Zemek R, Sveistrup H. Balance markers in adolescents at 1 month postconcussion. *Orthop J Sports Med.* 2017;5(3):2325967117695507.

144. Cavanaugh JT, Guskiewicz KM, Stergiou N. A nonlinear dynamic approach for evaluating postural control: new directions for the management of sport-related cerebral concussion. *Sports Med.* 2005;35(11):935-50.
145. Kirchner M, Schubert P, Schmidtbleicher D, Haas C. Evaluation of the temporal structure of postural sway fluctuations based on a comprehensive set of analysis tools. *Physica A: Statistical Mechanics and its Applications.* 2012;391(20):4692-703.
146. Montesinos L, Castaldo R, Pecchia L. On the use of approximate entropy and sample entropy with centre of pressure time-series. *J Neuroeng Rehabil.* 2018;15(1):116.
147. Broglio SP, Macciocchi SN, Ferrara MS. Sensitivity of the concussion assessment battery. *Neurosurgery.* 2007;60(6):1050-7; discussion 7-8.
148. Cavanaugh JT, Guskiewicz KM, Giuliani C, Marshall S, Mercer VS, Stergiou N. Recovery of postural control after cerebral concussion: new insights using approximate entropy. *J Athl Train.* 2006;41(3):305.
149. Guskiewicz KM, Riemann BL, Perrin DH, Nashner LM. Alternative approaches to the assessment of mild head injury in athletes. *Med Sci Sports Exerc.* 1997;29(7 Suppl):S213-21.
150. Peterson CL, Ferrara MS, Mrazik M, Piland S, Elliott R. Evaluation of neuropsychological domain scores and postural stability following cerebral concussion in sports. *Clin J Sport Med.* 2003;13(4):230-7.

151. Ruhe A, Fejer R, Gänsslen A, Klein W. Assessing postural stability in the concussed athlete: what to do, what to expect, and when. *Sports health*. 2014;6(5):427-33.
152. Marshall CM. Sports-related concussion: A narrative review of the literature. *J Can Chiropr Assoc*. 2012;56(4):299-310.
153. Morin M, Langevin P, Fait P. Cervical spine involvement in mild traumatic brain injury: a Review. *J Sports Med*. 2016;2016:1590161.
154. Schneider KJ, Palacios-Derflingher L, Meeuwisse WH, Emery CA. Changes in measures of cervical, vestibular, dynamic balance and tasks of divided attention following sport-related concussions in elite youth ice hockey players. *Br J Sports Med*. 2017;51(11):A47-A8.
155. Allison L. Imbalance following traumatic brain injury in adults: causes and characteristics. *J Neurol Phys Ther*. 1999;23(1):13-8.
156. Register-Mihalik JK, Mihalik JP, Guskiewicz KM. Balance deficits after sports-related concussion in individuals reporting posttraumatic headache. *Neurosurgery*. 2008;63(1):76-80; discussion -2.
157. Cheever K, Kawata K, Tierney R, Galgon A. Cervical injury assessments for concussion evaluation: a review. *J Athl Train*. 2016;51(12):1037-44.
158. Brachman A, Kamieniarz A, Michalska J, Pawłowski M, Słomka KJ, Juras G. Balance training programs in athletes—a systematic review. *J Hum Kinet*. 2017;58(1):45-64.

159. Aaltonen S, Karjalainen H, Heinonen A, Parkkari J, Kujala UM. Prevention of sports injuries: systematic review of randomized controlled trials. *Arch Intern Med.* 2007;167(15):1585-92.
160. van Mechelen W, Hlobil H, Kemper HC. Incidence, severity, aetiology and prevention of sports injuries. A review of concepts. *Sports Med.* 1992;14(2):82-99.
161. McMichael KA, Vander Bilt J, Lavery L, Rodriguez E, Ganguli M. Simple balance and mobility tests can assess falls risk when cognition is impaired. *Geriatr Nurs.* 2008;29(5):311-23.
162. Eckner JT, Whitacre RD, Kirsch NL, Richardson JK. Evaluating a clinical measure of reaction time: an observational study. *Percept Mot Skills.* 2009;108(3):717-20.
163. Ross LM, Register-Mihalik JK, Mihalik JP, McCulloch KL, Prentice WE, Shields EW, et al. Effects of a single-task versus a dual-task paradigm on cognition and balance in healthy subjects. *J Sport Rehabil.* 2011;20(3):296-310.
164. Howell DR, Meehan III WP, Barber Foss KD, Reches A, Weiss M, Myer GD. Reduced dual-task gait speed is associated with visual Go/No-Go brain network activation in children and adolescents with concussion. *Brain Inj.* 2018;32(9):1129-34.
165. Huxham FE, Goldie PA, Patla AE. Theoretical considerations in balance assessment. *Aust J Physiother.* 2001;47(2):89-100.
166. Margolesky J, Singer C. How tandem gait stumbled into the neurological exam: a review. *J Neurol Sci.* 2018;39(1):23-9.

167. Council NR, Youth CoS-RCi. Sports-related concussions in youth: improving the science, changing the culture: National Academies Press; 2014.
168. Hansen C, Cushman D, Chen W, Bounsanga J, Hung M. Reliability testing of the balance error scoring system in children between the ages of 5 and 14. *Clin J Sport Med.* 2017;27(1):64.
169. Riemann BL, Guskiewicz KM, Shields EW. Relationship between clinical and forceplate measures of postural stability. *J Sport Rehabil.* 1999;8(2):71-82.
170. Alsalaheen BA, Haines J, Yorke A, Stockdale K, P. Broglio S. Reliability and concurrent validity of instrumented balance error scoring system using a portable force plate system. *Phys Sportsmed.* 2015;43(3):221-6.
171. Quatman-Yates C, Hugentobler J, Ammon R, Mwase N, Kurowski B, Myer GD. The utility of the balance error scoring system for mild brain injury assessments in children and adolescents. *Phys Sportsmed.* 2014;42(3):32-8.
172. Koyama S, Tanabe S, Itoh N, Saitoh E, Takeda K, Hirano S, et al. Intra-and inter-rater reliability and validity of the tandem gait test for the assessment of dynamic gait balance. *Eur J Physiother.* 2018;20(3):135-40.
173. Eckner JT, Richardson JK, Kim H, Joshi MS, Oh YK, Ashton-Miller JA. Reliability and criterion validity of a novel clinical test of simple and complex reaction time in athletes. *Percept Mot Skills.* 2015;120(3):841-59.

174. Woollacott M, Shumway-Cook A. Attention and the control of posture and gait: a review of an emerging area of research. *Gait Posture*. 2002;16(1):1-14.
175. Fraizer EV, Mitra S. Methodological and interpretive issues in posture-cognition dual-tasking in upright stance. *Gait Posture*. 2008;27(2):271-9.
176. Yogev-Seligmann G, Hausdorff JM, Giladi N. The role of executive function and attention in gait. *Mov Disord*. 2008;23(3):329-42; quiz 472.
177. Al-Yahya E, Dawes H, Smith L, Dennis A, Howells K, Cockburn J. Cognitive motor interference while walking: a systematic review and meta-analysis. *Neurosci Biobehav Rev*. 2011;35(3):715-28.
178. Portney LG, Watkins MP. *Foundations of clinical research: applications to practice*. 2nd ed. NJ: Prentice Hall Upper Saddle River; 2000.
179. Atkinson G, Nevill AM. Statistical methods for assessing measurement error (reliability) in variables relevant to sports medicine. *Sports Med*. 1998;26(4):217-38.
180. Barber-Westin SD, Noyes FR, McCloskey JW. Rigorous statistical reliability, validity, and responsiveness testing of the Cincinnati knee rating system in 350 subjects with uninjured, injured, or anterior cruciate ligament-reconstructed knees. *Am J Sports Med*. 1999;27(4):402-16.
181. Walter SD, Eliasziw M, Donner A. Sample size and optimal designs for reliability studies. *Stat Med*. 1998;17(1):101-10.

182. Anastasi A. Psychological Testing. 6th ed. New York: Macmillan;1988.
183. Koo TK, Li MY. A guideline of selecting and reporting intraclass correlation coefficients for reliability research. *J Chiropr Med.* 2016;15(2):155-63.
184. Roebroeck ME, Harlaar J, Lankhorst GJ. The application of generalizability theory to reliability assessment: an illustration using isometric force measurements. *Phys Ther.* 1993;73(6):386-95.
185. Bland JM, Altman D. Statistical methods for assessing agreement between two methods of clinical measurement. *The lancet.* 1986;327(8476):307-10.
186. McHugh ML. Interrater reliability: the kappa statistic. *Biochem Med (Zagreb).* 2012;22(3):276-82.
187. Loosveldt G. International handbook of survey methodology: Taylor & Francis Group/Lawrence Erlbaum Associates; 2008.
188. Eckner JT, Kutcher JS, Richardson JK. Between-seasons test-retest reliability of clinically measured reaction time in National Collegiate Athletic Association Division I athletes. *J Athl Train.* 2011;46(4):409-14.
189. Valovich TC, Perrin DH, Gansneder BM. Repeat administration elicits a practice effect with the balance error scoring system but not with the standardized assessment of concussion in high school athletes. *J Athl Train.* 2003;38(1):51.

190. Broglio SP, Zhu W, Sapienza K, Park Y. Generalizability theory analysis of balance error scoring system reliability in healthy young adults. *J Athl Train.* 2009;44(5):497-502.
191. Nguyen CN, Clements RN, Porter LA, Clements NE, Gray MD, Baker RT. Examining practice and learning effects with serial administration of the clinical reaction time test in healthy young athletes. *J Sport Rehabil.* 2018;28(6):558-63.
192. Horak FB, Wrisley DM, Frank J. The Balance Evaluation Systems Test (BESTest) to differentiate balance deficits. *Phys Ther.* 2009;89(5):484-98.
193. Woods DL, Wyma JM, Yund EW, Herron TJ, Reed B. Factors influencing the latency of simple reaction time. *Front Hum Neurosci.* 2015;9:131.
194. Johnson RL, Morgan GB. *Survey scales: a guide to development, analysis, and reporting.* NY: Guilford Publications; 2016.
195. Terwee CB, Prinsen CAC, Chiarotto A, Westerman MJ, Patrick DL, Alonso J, et al. COSMIN methodology for evaluating the content validity of patient-reported outcome measures: a Delphi study. *Qual Life Res.* 2018;27(5):1159-70.
196. Smith FW, Rosenlund EA, Aune AK, MacLean JA, Hillis SW. Subjective functional assessments and the return to competitive sport after anterior cruciate ligament reconstruction. *Br J Sports Med.* 2004;38(3):279-84.

197. Redline C, Smiley R, Lee M, DeMaio T, editors. Beyond concurrent interviews: an evaluation of cognitive interviewing techniques for self-administered questionnaires. Proceedings of the Section on Survey Research Methods, American Statistical Association; 1998: Citeseer.
198. Manaseer TS GD, Mrazik M, Schneider K, Whittaker JL. Re-conceptualizing postural control assessment in sport-related concussion: Transitioning from the Reflex/Hierarchical Model to the Systems Model. *Physiother Theory Pract.* 2019;Aug(1):1-2.
199. Grinnon ST, Miller K, Marler JR, Lu Y, Stout A, Odenkirchen J, et al. National institute of neurological disorders and stroke common data element project—approach and methods. *Clin Trials.* 2012;9(3):322-9.
200. Stewart PF, Turner AN, Miller SC. Reliability, factorial validity, and interrelationships of five commonly used change of direction speed tests. *Scand J Med Sci Sports.* 2014;24(3):500-6.
201. Chiwaridzo M, Ferguson GD, Smits-Engelsman BC. A systematic review protocol investigating tests for physical or physiological qualities and game-specific skills commonly used in rugby and related sports and their psychometric properties. *Syst Rev.* 2016;5(1):122.
202. Thomas TDSC, Comfort P, Jones PA. Comparison of change of direction speed performance and asymmetries between team-sport athletes: application of change of direction deficit. *Sports.* 2018;6(4):174.
203. Nimphius S, Callaghan SJ, Bezodis NE, Lockie RG. Change of direction and agility tests: Challenging our current measures of performance. *Strength Cond J.* 2018;40(1):26-38.

204. Sady MD, Vaughan CG, Gioia GA. Psychometric characteristics of the postconcussion symptom inventory in children and adolescents. *Arch Clin Neuropsychol*. 2014;29(4):348-63.
205. Williams G, Rosie J, Denisenko S, Taylor D. Normative values for the high-level mobility assessment tool (HiMAT). *Int J Rehabil Res*. 2009;16(7):370-4.
206. Han J, Anson J, Waddington G, Adams R, Liu Y. The role of ankle proprioception for balance control in relation to sports performance and injury. *Biomed Res Int*. 2015;2015:842804.
207. Corwin DJ, Wiebe DJ, Zonfrillo MR, Grady MF, Robinson RL, Goodman AM, et al. Vestibular deficits following youth concussion. *J Pediatr*. 2015;166(5):1221-5.
208. Reed-Jones RJ, Murray NG, Powell DW. Clinical assessment of balance in adults with concussion. *Semin Speech Lang*. 2014;35(03):186-95.
209. Manaseer TS, Gross DP, Mrazik M, Schneider K, Whittaker JL. Re-conceptualizing postural control assessment in sport-related concussion: Transitioning from the reflex/hierarchical model to the systems model. *Physiother Theory Pract*. 2019:1-12.
210. Clay MB, Glover KL, Lowe DT. Epidemiology of concussion in sport: a literature review. *J Chiropr Med*. 2013;12(4):230-51.
211. Gardner AJ, Quarrie KL, Iverson GL. The epidemiology of sport-related concussion: what the rehabilitation clinician needs to know. *J Orthop Sports Phys Ther*. 2019;49(11):768-78.

212. Chaouachi A, Castagna C, Chtara M, Brughelli M, Turki O, Galy O, et al. Effect of warm-ups involving static or dynamic stretching on agility, sprinting, and jumping performance in trained individuals. *J Strength Cond Res.* 2010;24(8):2001-11.
213. Jacqueline M SPRM. Evaluating evidence for conceptually related constructs using bivariate correlations. *Meas Eval Couns Dev.* 2017;50(4):270-4.
214. de Vet HC, Terwee CB, Mokkink LB, Knol DL. *Measurement in medicine: a practical guide.*: Cambridge University Press; 2011.
215. Manaseer TS WJ, Codi Issac, Schneider K, Gross DP. The rationale for, development and preliminary evaluation of the Functional Assessment of Balance in Concussion (FAB-C) Battery [dissertation]. University of Alberta; 2020.
216. Barlow M, Schlabach D, Peiffer J, Cook C. Differences in change scores and the predictive validity of three commonly used measures following concussion in the middle school and high school aged population. *Int J Sports Phys Ther.* 2011;6(3):150.
217. Manaseer TS WJ, Isaac C, Schneider K, Roberts MR, Gross DP. The reliability of clinical balance tests under single-task and dual-task testing paradigms in uninjured active youth and young adults. . *Int J Sports Phys Ther* 2019;[in press].
218. Shumway-Cook A, Baldwin M, Polissar NL, Gruber W. Predicting the probability for falls in community-dwelling older adults. *Phys Ther.* 1997;77(8):812-9.

219. Wrisley DM, Walker ML, Echternach JL, Strasnick B. Reliability of the dynamic gait index in people with vestibular disorders. *Arch Phys Med Rehabil.* 2003;84(10):1528-33.
220. Legters K, Whitney SL, Porter R, Buczek F. The relationship between the activities-specific Balance Confidence Scale and the Dynamic Gait Index in peripheral vestibular dysfunction. *Physiother Res Int.* 2005;10(1):10-22.
221. Whitney S, Wrisley D, Furman J. Concurrent validity of the Berg Balance Scale and the Dynamic Gait Index in people with vestibular dysfunction. *Physiother Res Int.* 2003;8(4):178-86.
222. Whitney SL, Wrisley DM, Marchetti GF, Gee MA, Redfern MS, Furman JM. Clinical measurement of sit-to-stand performance in people with balance disorders: validity of data for the Five-Times-Sit-to-Stand Test. *Phys Ther.* 2005;85(10):1034-45.
223. Lord SR, Murray SM, Chapman K, Munro B, Tiedemann A. Sit-to-stand performance depends on sensation, speed, balance, and psychological status in addition to strength in older people. *J Gerontol A Biol Sci Med Sci.* 2002;57(8):M539-43.
224. Alsalaheen BA, Whitney SL, Marchetti GF, Furman JM, Kontos AP, Collins MW, et al. Relationship between cognitive assessment and balance measures in adolescents referred for vestibular physical therapy after concussion. *Clin J Sport Med.* 2016;26(1):46.
225. Wrisley DM, Marchetti GF, Kuharsky DK, Whitney SL. Reliability, internal consistency, and validity of data obtained with the functional gait assessment. *Phys Ther.* 2004;84(10):906-18.

- 226.Lanska DJ, Goetz CG. Romberg's sign: development, adoption, and adaptation in the 19th century. *Neurology*. 2000;55(8):1201-6.
- 227.Podsiadlo D, Richardson S. The timed "Up & Go": a test of basic functional mobility for frail elderly persons. *J Am Geriatr Soc*. 1991;39(2):142-8.
- 228.Steffen TM, Hacker TA, Mollinger L. Age- and gender-related test performance in community-dwelling elderly people: Six-Minute Walk Test, Berg Balance Scale, Timed Up & Go Test, and gait speeds. *Phys Ther*. 2002;82(2):128-37.
- 229.Ries JD, Echternach JL, Nof L, Gagnon Blodgett M. Test-retest reliability and minimal detectable change scores for the timed "Up & Go" Test, the Six-Minute Walk Test, and gait speed in people with Alzheimer disease. *Phys Ther*. 2009;89(6):569-79.
- 230.Hyndman D, Ashburn A. "Stops walking when talking" as a predictor of falls in people with stroke living in the community. *J Neurol Neurosurg Psychiatry*. 2004;75(7):994-7.
- 231.Verghese J, Buschke H, Viola L, Katz M, Hall C, Kuslansky G, et al. Validity of divided attention tasks in predicting falls in older individuals: a preliminary study. *J Am Geriatr Soc*. 2002;50(9):1572-6.
- 232.Krishna R, Maithreyi R, Surapaneni K. Research bias: a review for medical students. *J Clin Diagn Res*. 2010;4(2):2320-4.

233. Buttner F, Howell DR, Ardern CL, Doherty C, Blake C, Ryan J, et al. Concussed athletes walk slower than non-concussed athletes during cognitive-motor dual-task assessments but not during single-task assessments 2 months after sports concussion: a systematic review and meta-analysis using individual participant data. *Br J Sports Med.* 2019;bjsports-2018-100164.
234. Wood TA, Hsieh KL, An R, Ballard RA, Sosnoff JJ. Balance and gait alterations observed more than 2 weeks after concussion: a systematic review and meta-analysis. *Am J Phys Med Rehabil.* 2019;98(7):566-76.
235. Grants L, Powell B, Gessel C, Hiser F, Hassen A. Gait deficits under dual-task conditions in the concussed adolescent and young athlete population: a systematic review. *Int J Sports Phys Ther.* 2017;12(7):1011.
236. Howell DR, Kirkwood MW, Provance A, Iverson GL, Meehan III WP. Using concurrent gait and cognitive assessments to identify impairments after concussion: a narrative review. *Concussion.* 2018;3(1):CNC54.
237. Howell DR, Brilliant AN, Meehan III WP. Tandem Gait test-retest reliability among healthy child and adolescent athletes. *J Athl Train.* 2019;54(12):1254-9.
238. DuBose DF, Herman DC, Jones DL, Tillman SM, Clugston JR, Pass A, et al. Lower extremity stiffness changes following concussion in collegiate football players. *Med Sci Sports Exerc.* 2017;49(1):167.

239. Alsalaheen BA, Mucha A, Morris LO, Whitney SL, Furman JM, Camiolo-Reddy CE, et al. Vestibular rehabilitation for dizziness and balance disorders after concussion. *J Neurol Phys Ther.* 2010;34(2):87-93.
240. Portney LG, Watkins MP. *Foundations of clinical research: applications to practice*: Pearson/Prentice Hall Upper Saddle River, NJ; 2009.
241. Peat J. *Health science research: A handbook of quantitative methods*. London: Sage; 2001.
242. Pourhoseingholi MA, Baghestani AR, Vahedi M. How to control confounding effects by statistical analysis. *Gastroenterol Hepatol Bed Bench.* 2012;5(2):79.
243. Sarto F, Grigoletto D, Baggio E, Paoli A, Marcolin G. Do lower limb previous injuries affect balance performance? An observational study in volleyball players. *Phys Ther Sport.* 2019;37:49-53.
244. Johnston W, Heiderscheit B, Sanfilippo J, Brooks MA, Caulfield B. Athletes with a concussion history in the last two years have impairments in dynamic balance performance. *Scand J Med Sci Sports.* 2020.
245. Mokkink LB, Terwee CB, Patrick DL, Alonso J, Stratford PW, Knol DL, et al. The COSMIN checklist for assessing the methodological quality of studies on measurement properties of health status measurement instruments: an international Delphi study. *Qual Life Res.* 2010;19(4):539-49.

246. Vandenbroucke JP, Von Elm E, Altman DG, Gøtzsche PC, Mulrow CD, Pocock SJ, et al. Strengthening the Reporting of Observational Studies in Epidemiology (STROBE): explanation and elaboration. *Ann Intern Med.* 2007;147(8):W-163-W-94.

247. Government of Canada, Canadian Institutes of Health Research, Institute Affairs. End of Grant knowledge translation [Internet]. CIHR. Canadian Institutes of Health Research; 2016 [cited 2020Mar30]. Available from: <https://cihr-irsc.gc.ca/e/29418.html#5.1>

Appendices

Appendix 1: Systematic Review – Search Strategies and Results

TABLE 1. Ovid Medline Search Strategy

Provider/Interface	Ovid
Database	Medline
Date searched	December 14, 2015. Updated September 29, 2016
Database update	—
Search developer(s)	TM & LD
Limit to English?	No
Date Range	1974–2016

1	exp brain hemorrhage, traumatic/
2	[concuss* or postconcuss* or acquired brain damage or acquired brain injur* or mTBI or traumatic brain injur* or minor brain injur* or minor head injur* or mild head injur* or commotio cerebri].mp.
3	[[brain injur* or brain damage or head injur*] adj12 [trauma* or accident* or hit or blow or fall*]].mp.
4	[gait or walk or walking or locomotion or ambulation or stride length or stride width or step length or step width or cadence or [[centre of mass or center or mass or range of motion] adj4 [displace* or sway*]]].mp.
5	(1 or 2 or 3) and 4
6	limit 5 to animals
7	limit 6 to humans
8	5 not (6 not 7)
9	limit 8 to “review articles”
10	8 not 9
11	[cadaver* or mouse or mice or rat or rats or rabbit* or pig or pigs or porcine or murine or sheep].ti.
12	10 not 11
13	case reports/
14	12 not 13

TABLE 2. SCOPUS search strategy

Provider/Interface	
Database	SCOPUS
Date searched	December 14, 2015. Updated September 29, 2016
Database update	—
Search developer(s)	TM & LD
English only?	NO
Date Range	1974–2016

1	<p>TITLE-ABS-KEY [concuss* OR postconcuss* OR “acquired brain damage” OR “acquired brain injur*” OR mtbi OR “traumatic brain injur*” OR “minor brain injur*” OR “minor head injur*” OR “mild head injur*” OR “ommotion cerebri”] AND TITLE-ABS-KEY [gait OR walk OR walking OR locomotion OR ambulation OR “stride length” OR “stride width” OR “step length” OR “step width” OR cadence OR “center of mass displacement” OR sway.]] AND [EXCLUDE [DOCTYPE, “re”] OR EXCLUDE [DOCTYPE, “cp”] OR EXCLUDE [DOCTYPE, “cr”]]</p>
---	---

TABLE 3. Ovid PsycINFO Search Strategy

Provider/Interface	Ovid
Database	PsycINFO
Date searched	December 14, 2015. Updated September 29, 2016
Database update	—
Search developer(s) TM & LD	
Limit to English?	No
Date Range	1974–2016

1	exp traumatic brain injury/
2	[concuss* or postconcuss* or acquired brain damage or acquired brain injur* or mTBI or traumatic brain injur* or minor brain injur* or minor head injur* or mild head injur* or commotio cerebri].mp.
3	[[brain injur* or brain damage or head injur*] adj12 [trauma* or accident* or hit or blow or fall*]].mp.
4	[gait or walk or walking or locomotion or ambulation or stride length or stride width or step length or step width or cadence or [[centre of mass or center or mass or range of motion] adj4 [displace* or sway*]]].mp.
5	(1 or 2 or 3) and 4
6	limit 5 to animal
7	limit 6 to human
8	5 not (6 not 7)
9	limit 8 to reviews
10	case report/
11	8 not 10

TABLE 4. CINAHL Search Strategy

Provider/Interface	Ebsco
Database	CINAHL
Date searched	December 14, 2015. Updated September 29, 2016
Database update	—
Search developer(s) TM & LD	
Limit to English?	No
Date Range	1974–2016

S1	[[MH “Brain Concussion1”] OR [MH “Right Hemisphere Injuries”]] OR [[concuss* or postconcuss* or “acquired brain damage” or “acquired brain injur*” or mTBI or “traumatic brain injur*” or “minor brain injur*” or “minor head injur*” or “mild head injur*” or “commotio cerebri”]] OR [[“brain injur*” or “brain damage” or head “injur*”] n12 [trauma* or accident* or hit or blow or fall*]]]
S2	gait or walk or walking or locomotion or ambulation or “stride length” or “stride width” or “step length” or “step width” or cadence or [[“centre of mass” or “center of mass” or “range of motion”] n4 [displace* or sway*]]]
S3	S1 AND S2
S4	PT case study or meta analysis or review
S5	S3 NOT S4
S6	TI cadaver* or mouse or mice or rat or rats or rabbit* or pig or pigs or porcine or murine or sheep
S7	S5 NOT S6

TABLE 5. Ovid EMBASE Search Strategy

Provider/Interface	Ovid
Database	EMBASE
Date searched	December 14, 2015. Updated September 29, 2016
Database update	—
Search developer(s) TM & LD	
Limit to English?	No
Date Range	1974–2016

1	Traumatic brain injury/
2	[concuss* or postconcuss* or acquired brain damage or acquired brain injur* or mTBI or traumatic brain injur* or minor brain injur* or minor head injur* or mild head injur* or commotio cerebri].mp.
3	[[brain injur* or brain damage or head injur*] adj12 [trauma* or accident* or hit or blow or fall*]].mp.
4	1 or 2 or 3
5	[gait or walk or walking or locomotion or ambulation or stride length or stride width or step length or step width or cadence or [[centre of mass or center or mass or range of motion] adj4 [displace* or sway*]]].mp.
6	4 and 5
7	limit 6 to animals
8	limit 7 to human
9	6 not 7
10	limit 9 to (conference abstract or “conference review” or “review”)
11	9 not 10
12	case report/
13	case study/
14	11 not (12 or 13)
15	[cadaver* or mouse or mice or rat or rats or rabbit* or pig or pigs or porcine or murine or sheep].ti.
16	14 not 15

TABLE 6. EBSCO SportDiscus Search Strategy

Provider/Interface	Ovid
Database	EMBASE
Date searched	December 14, 2015. Updated September 29, 2016
Database update	—
Search developer(s) TM & LD	
Limit to English?	No
Date Range	1974–2016
S1	[[concuss* or postconcuss* or “acquired brain damage” or “acquired brain injur*” or mTBI or “traumatic brain injur*” or “minor brain injur*” or “minor head injur*” or “mild head injur*” or “commotio cerebri”] OR [[“brain injur*” or “brain damage” or head “injur*”] n12 [trauma* or accident* or hit or blow or fall*]]
S2	Gait or walk or walking or locomotion or ambulation or “stride length” or “stride width” or “step length” or “step width” or cadence or [“[centre of mass” or “center of mass” or “range of motion”] n4 [displace* or sway*]]]
S3	S1 AND S2
S4	[S1 AND S2] NOT TI [cadaver* or mouse or mice or rat or rats or rabbit* or pig or pigs or porcine or murine or sheep]

Appendix 2: Systematic Review – Unique Articles Identified by Database

Database	Items Found	Internal Duplicates	External Duplicates	Unique Items
MEDLINE	466	8	172	286
PsycINFO	217	0	25	192
CINAHL	244	1	0	243
EMBASE	552	13	303	236
SCOPUS	969	5	538	426
Sport Discus	202	2	120	80

Appendix 3: Bland-Altman Plots for the BESS, TGT, and CRT under Single-Task and Dual-Task Testing Conditions.

Bland-Altman plots of the difference in postural control tests between trials and between sessions against the mean difference. The solid horizontal lines represent the mean difference. The dashed horizontal lines represent the 95% upper and lower limits of agreement.

A. Balance Error Scoring System- Single-task (errors)

B. Balance Error Scoring System- Dual-task (errors)

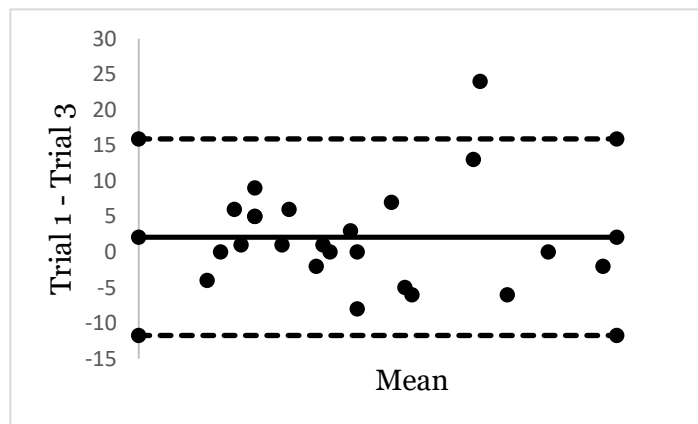
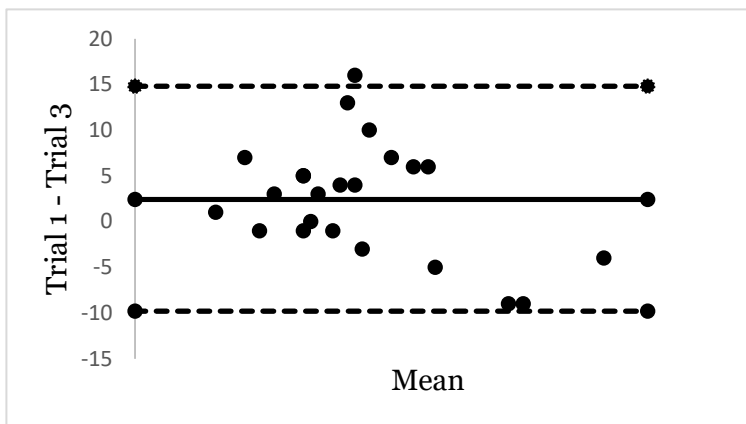

C. Tandem Gait Test- Single-task (seconds)

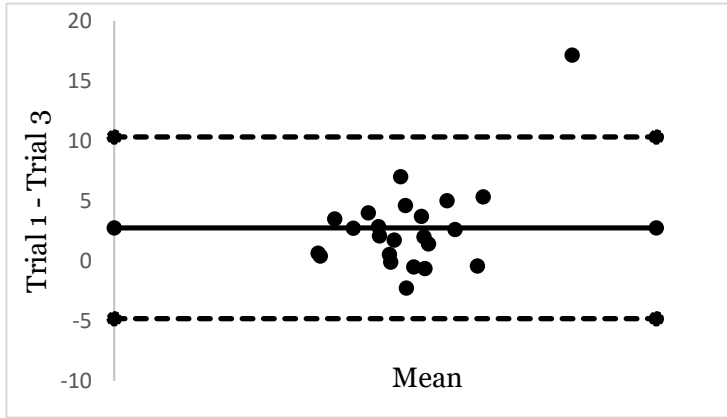

D. Tandem Gait Test- Dual-task (seconds)

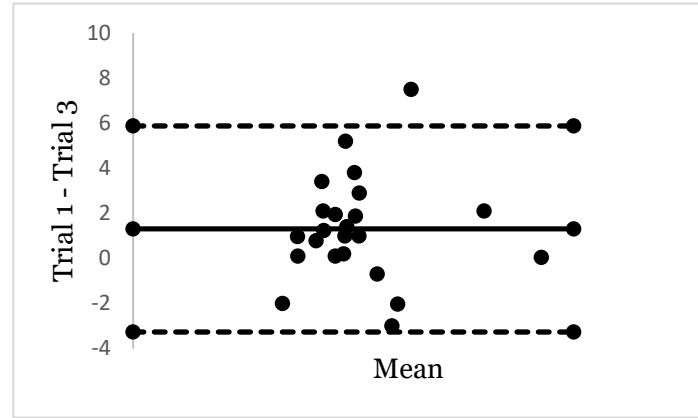

E. Clinical Reaction Time- Single-task (millisecond)

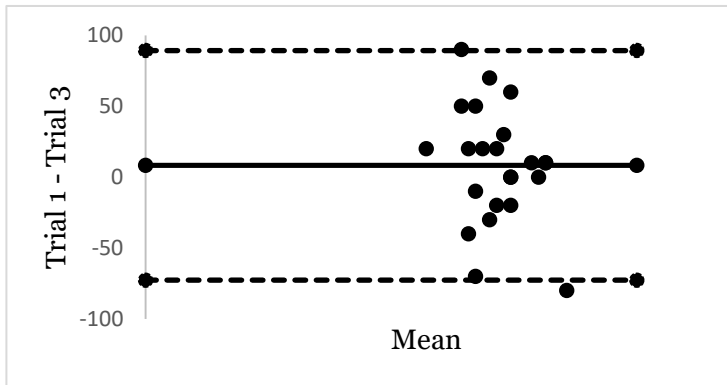

F. Clinical Reaction Time- Dual-task (millisecond)

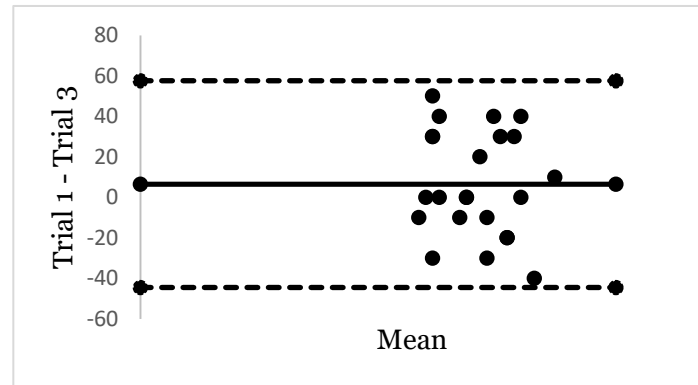

g. Balance Error Scoring System- Single-task (errors)

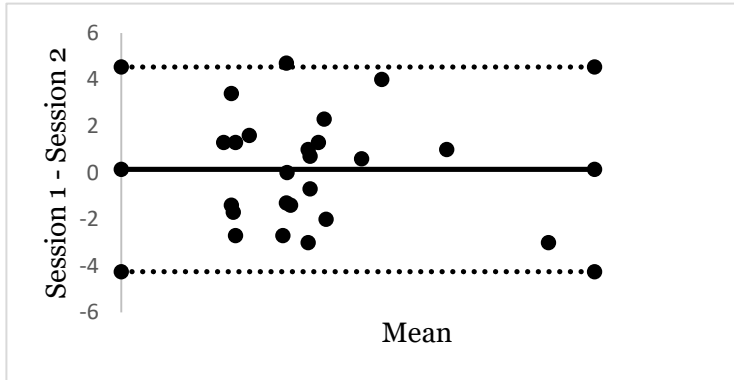

h. Balance Error Scoring System- Dual-task (errors)

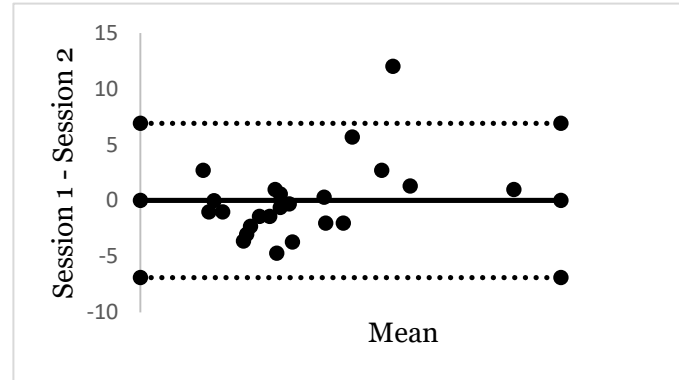

i. Tandem Gait Test- Single-task (seconds)

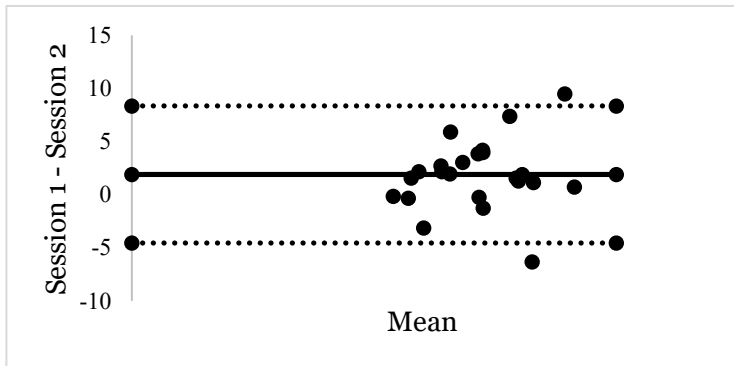

j. Tandem Gait Test- Dual-task (seconds)

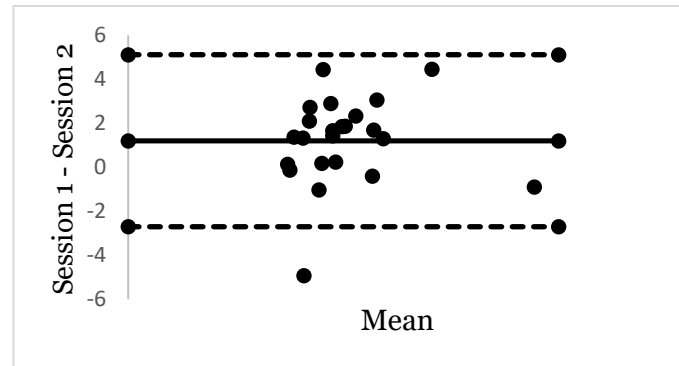

k. Clinical Reaction Time- Single-task (millisecond)

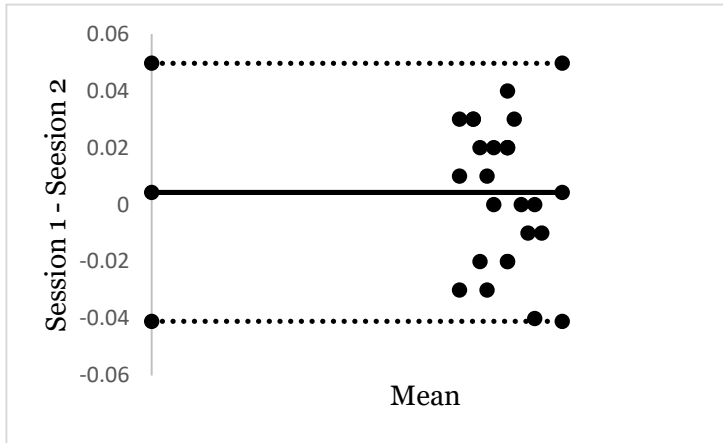

l. Clinical Reaction Time- Dual-task (millisecond)

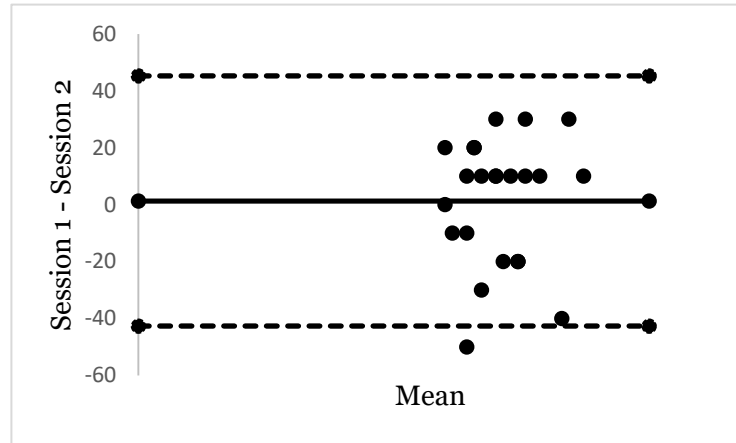

Appendix 4: The Preliminary Version of a Sport-Related Postural Control Test for Postural Control Assessment following Sport-Related Concussion.

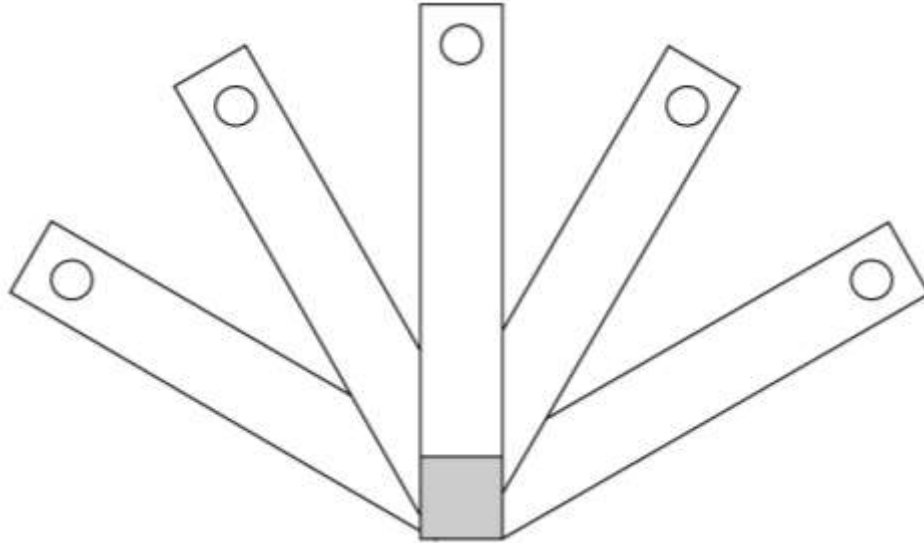

Figure 1. The design of the preliminary version of a sport-related postural control test for postural control assessment following sport-related concussion. The gray area shows the starting point. Five paths are arranged on the floor in a semicircle at different angles (30, 60, and 90 degrees) from the midline. The length and width of each path are assigned based on an individual's lower limb length and shoulder width respectively. A tested individual is asked to run from the starting point, pass beyond the end points (plastic cones that are shown as coloured circles in the figure) at the end of each path with both feet, turn around, and run back to the starting point. The order of endpoints are randomly assigned by the examiner (each endpoint has a different colour of cone). Total time an injured athlete needs to complete the task (moving through five paths) and ability to stay within the assigned paths (pass/fail) are record. A tested individual fails if steps off the assigned path.

Table 1: Modifications to the Sport-Related Postural Control Test Based on Feedback From Examiners and Pilot Study Participants

Feedback from examiners and participants	Changes
Using shoulder width and lower limb length to set the width or the length of the testing paths was time-consuming and is unlikely to be used in clinical practice.	The testing station was set at a standardized width of 38 cm, and length of 170 cm.
Using cones limited participants' ability to move within the assigned path to the best of their ability during the task. For instance, some participants moved slower as they got closer to a cone, so they didn't collide with it.	Cones were omitted as the testing station was changed to a standardized width and length.
The assigned paths overlapped when arranged at 30, 60, and 90 degrees from the midline. This made it difficult for the participants to stay within the intended path.	The arrangement of the paths was set at 90, 45, and 0 degrees instead of 30, 60, and 90 degrees.
The preliminary version of the sport-specific test required a participant to run forward within the intended path, turn around, and run back forward to the starting point. This task, however, didn't challenge side-shuffling or backward running, which are typically involved in sports. Therefore, we decided to add a variation of the task to identify postural control deficits while side-shuffling or backward running.	A variation of the sport specific test has been added. In the added variation of the test, an individual is instructed to keep his\her chest facing forward throughout testing.

<p>Participants were uncertain whether they could jump and/or reach instead of running, or if they were allowed to touch objects during the test.</p>	<p>The following was added to test instructions “You will be asked to repeat a trial if you jump, reach, or touch the examiner or an object during testing.”</p>
---	--

Appendix 5: The Final Sport-Related Postural Control Test with Scoring, Examiner, and Patient Instructions

Sport-Related Postural Control Test Following Sport-Related Concussion

1. Performance-based testing

For examiner – Please set the testing station as shown in the figure bellow. You need to record time (seconds) an examinee needs to finish the task (moving through five paths), and the examinee’s ability to stay inside the assigned path. An examinee fails if steps off the assigned path.

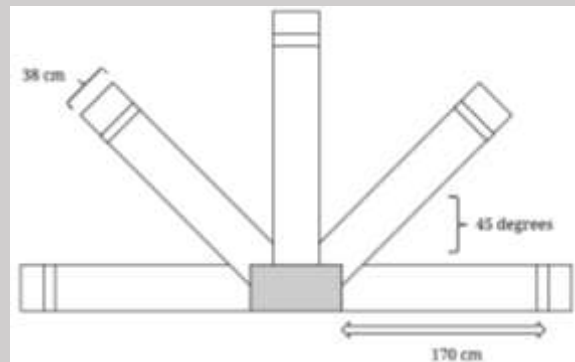

For examinee – “I am now going to test your ability to use postural control for sporting activity. Please stand with both feet inside the starting square. To be sure you are aware of the setup, please name the color of tape you see at the end of each track. When I call a color, run as fast as you can crossing over that color tape with both feet, then run back to the starting square. Once both feet are inside the square, I will call out the next color. Please note that you will be asked to repeat a trial if you jump (both feet not touching the floor), lunge (drag feet, or take only 1-2 big steps), or touch or grab the examiner or an object in the room. Try not to step outside the track.”

Turn and Go – “Please face the line, run straight forward, cross the line, turn around, and run back facing the starting square.”

Lateral Shuffle – “Please keep your chest facing forward across the line and back to the square. In this case, you may move in diagonals or backpedal as needed.”

	Time (second)				Pass\Fail			
	T 1	T 2	T 3	Avg	T 1	T 2	T 3	Avg
Turn and Go								
Lateral Shuffle				/3				/3
2. Symptom evaluation								
<p>For examiner - The checklist should be completed by the examinee. Allow a resting time (until the examinee is in a resting heart rate state) before completing the checklist.</p> <p>For examinee – “Please use the checklist to rate how you feel after performing the test.”</p>								
Symptom	None	Mild		Moderate		Severe		
Headache	0	1	2	3	4	5	6	
Pressure in head	0	1	2	3	4	5	6	
Neck pain	0	1	2	3	4	5	6	
Nausea or vomiting	0	1	2	3	4	5	6	
Dizziness	0	1	2	3	4	5	6	
Blurred vision	0	1	2	3	4	5	6	
Balance problems	0	1	2	3	4	5	6	
Sensitivity to light	0	1	2	3	4	5	6	

Sensitivity to noise	0	1	2	3	4	5	6
Feeling slowed down	0	1	2	3	4	5	6
Feeling like in fog	0	1	2	3	4	5	6
Don't feel right	0	1	2	3	4	5	6
Difficulty concentrating	0	1	2	3	4	5	6
Difficulty remembering	0	1	2	3	4	5	6
Fatigue or low energy	0	1	2	3	4	5	6
Confusion	0	1	2	3	4	5	6
Drowsiness	0	1	2	3	4	5	6
More emotional	0	1	2	3	4	5	6
Irritability	0	1	2	3	4	5	6
Sadness	0	1	2	3	4	5	6
Nervous or Anxious	0	1	2	3	4	5	6

Total number of symptoms	/ 21	
Symptom severity score	/ 126	
Do your symptoms get worse with physical activity?	Yes	No
Do your symptoms get worse with mental activity?	Yes	No
If 100% is feeling perfectly normal, what percent of normal do you feel?	/100	
If not 100%, why? <hr/> <hr/>		

Appendix 6: The Functional Assessment of Balance in Concussion (FAB-C)

Name:

Please check one: **Baseline** **Post-injury**

PART I: SCORING SHEET

1. Sensory Strategies components: Measured with Balance Error Scoring System (number of errors)								
<p>For the examinee – “I am now going to test your postural control. Please take your shoes off (if applicable), roll up your pant legs above ankle (if applicable), and remove any ankle taping (if applicable). This test will consist of three twenty second tests with different stances. “</p> <p>Dual Task Numbers - 199, 195, 189, 197, 193, 187, 183, 175, 169, 181, 173, 167, 178, 164, 153, 176, 174, and 151</p>								
	Single Task Testing				Dual Task Testing			
Firm surface	T 1	T 2	T 3	Avg	T 1	T 2	T 3	Avg
Double leg stance								
Single leg stance (non-dominant foot)								
Tandem stance (non-dominant foot at back)								
Foam surface	T 1	T 2	T 3	Avg	T 1	T 2	T 3	Avg
Double leg stance								
Single leg stance (non-dominant foot)								
Tandem stance (non-dominant foot at back)								

Total per trial								
2. Control of Dynamics component: Measured with Timed Tandem Gait Test (time and accuracy)								
<p>For the examinee – “I am now going to test your dynamic postural control. Please stand with feet together behind the start line. When I say ‘GO’, walk forward as quickly and accurately as you can along the 3-meter line, alternating foot heel-to-toe gait ensure your heel touches your toe on every step. Once you cross the end line, turn 180 degrees and return to the starting point.”</p> <p>Dual Task Words - elbow, paper, lemon, wagon, honey, Japan</p>								
	T 1	T 2	T 3	Avg	T 1	T 2	T 3	Avg
Seconds								
Pass/Fail (use trial 3)								
3. Movement Strategies component: Measured with Clinical Reaction Time Test (milliseconds)								
<p>For the examinee – “I am now going to test your reaction time. Please sit comfortably next to a table resting your dominant forearm on it. Leave your hand off the edge of the table. Randomly, I will release the stick. You need to catch the falling stick as quickly as you can.”</p> <p>Dual Task Words - sugar, movie, apple</p>								
	T 1	T 2	T 3	Avg	T 1	T 2	T 3	Avg
Distance (to nearest .5 cm)								
Reaction time (milliseconds)								
4. Interaction between components: Measured with sport-related postural control tests (time and accuracy)								

For examinee – “I am now going to test your ability to control posture for sporting activity. Please stand with both feet inside the starting square. To be sure you are aware of the setup, please name the color of tape you see at the end of each track. When I call a color, run as fast as you can crossing over that color tape with both feet, then run back to the starting square. Once both feet are inside the square, I will call out the next color. Please note that you will be asked to repeat a trial if you jump (both feet not touching the floor), lunge (drag feet, or take only 1-2 big steps), touch or grab the examiner or an object in the room. Try not to step outside the track.”

Turn and Go – “Please face the line, run straight forward, cross the line, turn around, and run back facing the starting square.”

Lateral Shuffle – “Please keep your chest facing forward across the line and back to the square. In this case, you may move in diagonals or backpedal as needed.”

	Turn and go				Lateral Shuffle			
	T 1	T 2	T 3	Avg	T 1	T 2	T 3	Avg
Seconds								
Pass/Fail				/3				/3

Symptom evaluation

For the examinee – “Please use the checklist to rate how you feel after performing the test.”

Symptom	None	Mild		Moderate		Severe	
Headache	0	1	2	3	4	5	6
Pressure in head	0	1	2	3	4	5	6
Neck pain	0	1	2	3	4	5	6
Nausea or vomiting	0	1	2	3	4	5	6
Dizziness	0	1	2	3	4	5	6
Blurred vision	0	1	2	3	4	5	6
Balance problems	0	1	2	3	4	5	6
Sensitivity to light	0	1	2	3	4	5	6
Sensitivity to noise	0	1	2	3	4	5	6
Feeling slowed down	0	1	2	3	4	5	6
Feeling like in fog	0	1	2	3	4	5	6
Don't feel right	0	1	2	3	4	5	6
Difficulty concentrating	0	1	2	3	4	5	6
Difficulty remembering	0	1	2	3	4	5	6
Fatigue or low energy	0	1	2	3	4	5	6
Confusion	0	1	2	3	4	5	6
Drowsiness	0	1	2	3	4	5	6
More emotional	0	1	2	3	4	5	6
Irritability	0	1	2	3	4	5	6

Sadness	0	1	2	3	4	5	6
Nervous or Anxious	0	1	2	3	4	5	6
Trouble falling asleep (if applicable)	0	1	2	3	4	5	6
Total number of symptoms						/ 22	
Symptom severity score						/ 132	
Do your symptoms get worse with physical activity?						Yes	No
Do your symptoms get worse with mental activity?						Yes	No
If 100% is feeling perfectly normal, what percent of normal do you feel?						/100	
If not 100%, why?							

Clinical Notes:

PART II: INSTRUCTION SHEET.

Instruct tested individuals to keep their shoes on throughout testing.

The Balance Error Scoring System (number of errors)

Each trial is scored by counting errors (deviations from the proper stance). If multiple errors occur at the same time, only one is counted. The maximum number of errors for a single condition is 10. Errors include moving hands off of iliac crests, opening eyes, a step, stumble or fall, abduction or flexion of the hip beyond 30 degrees, lifting forefoot or heel off the testing surface, remaining out of the proper testing position for > 5 seconds. Number of errors in each trial are added together to obtain a total score (out of 60). For dual-task testing, use the same scoring process as an examinee performing the test while subtracting by 7s from a randomly assigned number (a suggested list of numbers for each trial is provided in the scoring sheet).

The Timed Tandem Gait Test (time and accuracy)

Time that a participant needs to complete the test as well as the participants' ability to successfully complete the test are recorded. A participant fails the test if he/she steps off the line, have a separation between heel and toe, or if he/she touches or grabs the examiner or an object. For dual-task testing, use the same scoring process as an examinee performing the test while spelling-out a five-letter word backwards (a list of suggested words for each trial is provided in the scoring sheet). Note that you may need two words for each trial to keep an examinee busy throughout the trial.

The Clinical Reaction Time (milliseconds)

The distance the apparatus falls will be recorded, in centimeters, by measuring from the top of the disk to the most superior aspect of the participant's hand. This distance will be converted to clinical reaction time, in milliseconds, using the formula for a free body falling under the influence of gravity ($d = \frac{1}{2}gt^2$; where d = distance, $g = 9.8 \text{ m/s}^2$, and t = time). For dual-task testing, use the same scoring process as an examinee performing the test while spelling-out a five-letter word backwards (a list of suggested words for each trial is provided in the scoring sheet).

Sport-related postural control tests

Set testing station as shown in the figure. Record time (seconds) an examinee needs to finish the test, as well as the examinee's ability to stay inside the assigned paths throughout testing. An examinee fails if he/she steps off the assigned path.

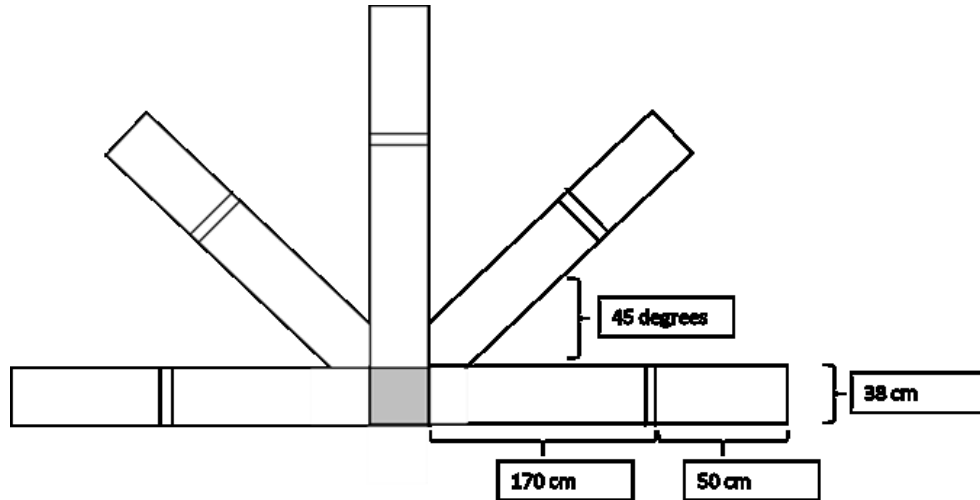

Symptom evaluation

The checklist should be completed by the examinee. Allow a resting time (until the examinee is in a resting heart rate state) before completing the checklist.