

## **THE GAUSSIAN BEAM MODE ANALYSIS OF PHASE GRATINGS**

Créidhe O'Sullivan<sup>1</sup>, J. Anthony Murphy<sup>1</sup>, Neil Trappe<sup>1</sup>, William Lanigan<sup>1</sup>, Ruth Colgan<sup>1</sup> & Stafford Withington<sup>2</sup>

<sup>1</sup>Experimental Physics Department, National University of Ireland, Maynooth, Co. Kildare, Ireland

<sup>2</sup>Cavendish Laboratory, Cambridge University, Madingley Road, Cambridge CB3 0HE, England

**Abstract:** Phase gratings find useful application in array receivers as passive multiplexing devices in the local oscillator injection chain. In particular, the Dammann phase grating is one of the simplest class to model and manufacture, and can be used to generate multiple images of a single input beam in a quasi-optical system. It is a binary grating consisting of a regular arrangement of milled slots or recesses in some suitable transparent dielectric or conducting block of material. The basic operation of the phase grating can be understood in terms of Fourier optics. However, Gaussian beam mode analysis is a powerful tool when investigating the limitation of the grating in a real submillimeter system of finite throughput and bandwidth. This is especially the case when evaluating the coupling to an array of horn antenna feeds. In this paper we present the results of our investigation into the modelling of phase gratings using Gaussian beam modes analysis and discuss new experimental measurements.

### **Introduction**

Phase gratings are now being incorporated into submillimeter-wave array receivers as low loss multipliers in the local oscillator injection optics [1-3]. Such quasi-optical devices have the advantage in the submillimeter waveband of being straightforward to manufacture, the required tolerances being relatively easy to achieve compared with their visible-wavelength counterparts. As well as the possibility of manufacturing reflection gratings, there are also a number of dielectric materials whose mechanical and optical properties in the far infrared make them ideal candidates for use in transmission phase gratings [4]. In our investigations we have concentrated on the Dammann Grating (DG) which is a binary optical component, that is the optical path length through the grating takes on just two values ideally separated by half a wavelength [5-8].

The theoretical analysis of phase grating multiplexers is important in determining the practical limitations of such devices in quasi-optical LO injection schemes. Ultimately, it is important to be able to produce quasi-uniform power coupling across an array of mixer feed horns over some useful bandwidth (typically of the order of 10% for ground based astronomical systems covering a submillimeter atmospheric window). Since Gaussian beam mode analysis is ideally suited to the analysis of coupling efficiencies in the case of typical horn antennas [9], and is also useful in analysing submillimeter optical systems of finite throughput [10], it was chosen as the optical analysis tool in this investigation.

In this paper we also report on experimental measurements made on transmission Dammann phase gratings. Three different gratings, designed to produce  $2 \times 2$ ,  $3 \times 3$  &  $5 \times 5$  uniform two-dimensional arrays of images at 100GHz, were manufactured and tested as quasi-optical multiplexers. It was decided to test the principles involved at this frequency since both the manufacture and experimental measurements are easier. Such phase gratings can, of course, be designed for the submillimeter/terahertz wavebands. The test facility consisted of a simple Fourier  $4-f$  optics set-up with a conical horn antenna fed by a Gunn diode source of variable frequency (90-105 GHz). The results presented confirm such gratings to be particularly suitable multiplexers for sparse arrays of finite bandwidth.

### Basic Theory of Multiplexer

As indicated above, the basic operation of a phase grating multiplexer can be understood in terms of Fourier optics. The grating is best illuminated by a quasi-collimated incident field  $\psi(x,y)$  produced by the source feed, this being achieved by arranging that the source beam has a waist at the grating (Figure 1). A Dammann grating consists of a two dimensional array of identical basis cells, with the transmission function of the (on-axis) basis cell being given by  $t(x,y)$ . Since a binary grating implies a phase step difference of  $\pi$  then  $t(x,y) = \pm 1$ . In the example of the basic period of a one-dimensional cut through a grating shown in Figure 2, the free parameters are  $\pm x_1$ ,  $\pm x_2$ ,  $\pm x_3$ , etc. The transmission of an entire grating with rectangular symmetry is then given by a sum of the form:  $\sum_{m,n} t(x-m\Delta x, y-n\Delta y)$ , where  $\Delta x$  and  $\Delta y$  are the grating periods in the  $x$  and  $y$  directions, respectively. The grating then produces a strong corrugated modulation of the quasi-planar wavefront of the incident field, severely affecting the resulting beam pattern. At the Fourier plane of the grating an array of beams is produced as predicted by the Array Theorem, the intensity of the beams being determined by the diffraction pattern (i.e. the Fourier Transform) of a single cell  $T(u,v)$ .

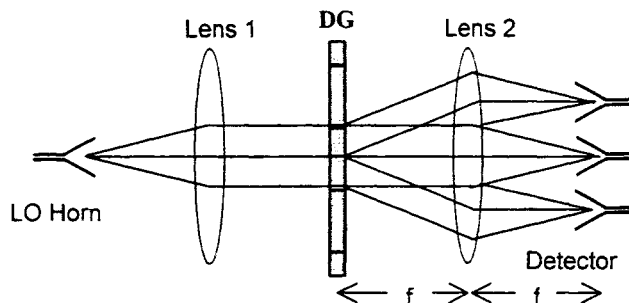

Figure 1 Optical set-up for beam multiplexing with a Dammann Grating.

At the output focal plane of the system illustrated in Figure 1 (the Fourier plane of the plane where the grating is placed), the diffraction pattern resulting is given by:

$$E(u, v) = \{T(u, v) \cdot \sum_{n, m=-\infty}^{\infty} \delta(u - m\Delta u, v - n\Delta v)\} * \Psi(u, v),$$

where  $\Psi(u, v)$  is the Fourier Transform of  $\psi(x, y)$ , the incident field at the grating, and capital symbols represent Fourier Transforms [11]. The pattern can thus be described mathematically as an array of spots (delta functions) convolved with the output LO beam that would have been obtained directly in the absence of the grating. The spatial frequencies  $u$  and  $v$  are related to the co-ordinates in the output plane through  $u = x_o / \lambda f$  and  $v = y_o / \lambda f$ ,  $f$  being the focal length of the lens. The array of beams are separated by a common distance of  $\Delta u = 1/\Delta x$  in the  $x$ -direction and  $\Delta v = 1/\Delta y$  in the  $y$ -direction, and correspond to the different diffraction orders of a uniformly illuminated grating. In the  $x$ -direction for example, the different grating orders are centred at  $u = m \Delta u$ , where  $m$  is some integer, equivalent, of course, to the usual grating formula:  $n\lambda = d \sin \theta$ .

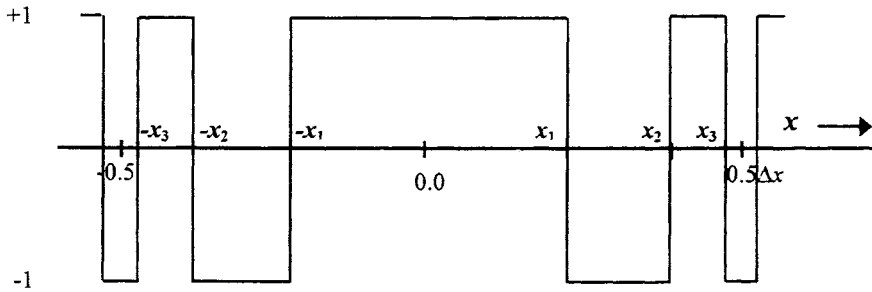

Figure 2 One-dimensional, symmetric binary function with period  $\Delta x$ .

The grating will usually possess rectangular symmetry, so that one can write  $t(x, y) = t(x)t(y)$ , and only the one-dimensional response of the grating need be considered. Then, if we require a  $2M+1$  array of non-overlapping images of the source beam of equal intensity in the  $x$ -direction,  $T(u)$ , must satisfy  $|T(m\Delta u)| = |T(0)|$  for  $m$  between  $-M$  and  $M$  (giving  $2M+1$  diffraction orders of equal intensity), and  $T(m\Delta u) \approx 0$ , otherwise, for high efficiency. To ensure this in terms of a Dammann grating the values of  $\pm x_1, \pm x_2, \pm x_3$ , etc. mentioned above must be chosen for a single period (cell) of the grating. This is discussed in detail in [5], where various solutions are tabulated for different values of  $M$ . Given that  $t(x) = \pm 1$ , one can show that  $T(u)$  is given by:

$$T(u) = \frac{1}{\pi u} \sum_{n=0}^N (-1)^n (\sin 2\pi u x_{n+1} - \sin 2\pi u x_n),$$

where  $N$  is the number of transition points between  $x = 0$  and  $\Delta x/2$ .

If an even number of output spots is required then neighbouring elements must be out of phase by  $\pi$ . This will cause the grating maxima to lie not in the direction given by  $n\lambda = d \sin \theta$ , but rather  $(n + 1/2)\lambda = d \sin \theta$ , where  $d$  is the original cell size, and an even number of equal intensity diffraction spots is obtained [12].

### Design of Grating

Now we consider applying the above theory to the design of the multiplexer shown in Figure 1 to produce an array of output beams arranged on a square grid. The position and widths of the slots making up the basis cell determine the number of beams in the array. If we require a diffraction order spacing (the inter-beam spacing on the output plane) of  $\Delta x_o$ , then the grating period  $\Delta x$  is determined by  $\Delta x = \lambda f / \Delta x_o$ . The number of gratings cells illuminated by the source beam determines the ratio of the output beam spacing to beam width. If one assumes a transmitting scalar feed (corrugated horn) as the source, then, to a good approximation the resulting propagating beam can be considered to have a simple Gaussian field distribution, whose form does not change as the beam propagates. At the grating we can write the incident field  $\psi(x,y) \propto \exp(-(x^2+y^2)/W_G^2)$ , where  $W_G$  is the usual Gaussian beam waist radius for the source beam. At the output Fourier plane  $\psi(x_o,y_o) \propto \exp(-(x_o^2+y_o^2)/W_F^2)$ , where for this Fourier arrangement  $W_F = \lambda f / \pi W_G$ . This implies  $W_G/\Delta x = [\pi(W_F/\Delta x_o)]^{-1}$ , so that the incident beam width to cell size ratio at the grating is inversely proportional to the beam width to inter-beam spacing for the array of images at the output plane.

Consider, for example, the situation where we want to couple the output array of beams from the multiplexer to an array of closely spaced diagonal horns (a typical scenario for quasi-optical local oscillator injection in an astronomical heterodyne array receiver system). The best-fit Gaussian beam to the field at the mouth of a diagonal horn has a radius given by:  $W = 0.43a$  [13]. For a horn of finite length the beam waist radius at the horn phase centre will be somewhat less than this, a typical value for a horn of moderate length being:  $W_{oh} = 0.38a$ . Thus, to match this radius to the incident LO beams ( $W_F = W_{oh} = 0.38\Delta x_o$ ), the corresponding beam width,  $W_G$ , at the grating must be:  $W_G = \lambda f / \pi W_F = \lambda f / \pi(0.38a) = 0.837\Delta x$ . The Gaussian beam radius is of order the grating period! The implications of this for the phase array is that we only need a *small number* of periods in the grating, reducing the complexity for manufacture.

The theoretically predicted resulting set of image Gaussian beams is shown in Figure 3, for the case where the total number of periods in the DG equals  $4 \times 4$ . The grating is designed to produce a  $5 \times 5$  array of images with the slot edges of the basis cell in

the  $x$ -direction at  $x_1 = \pm 0.132\Delta x$  &  $x_2 = \pm 0.480\Delta x$ . For comparison, a set of 5 Gaussian beams is shown in intensity and, as can be seen, the coupling is high. Since about 77.4% of the power is contained in the central orders for the one-dimensional case [5], the total LO coupling loss is of the order of 60% (in two dimensions). This power is lost into higher diffraction orders than 2, and so some power spills round the side of the array of diagonal horns. However, this power can be easily terminated using an absorbing microwave material around the array. It should also be possible to reduce loss by having a basic grating cell with more grooves (more degrees of freedom).

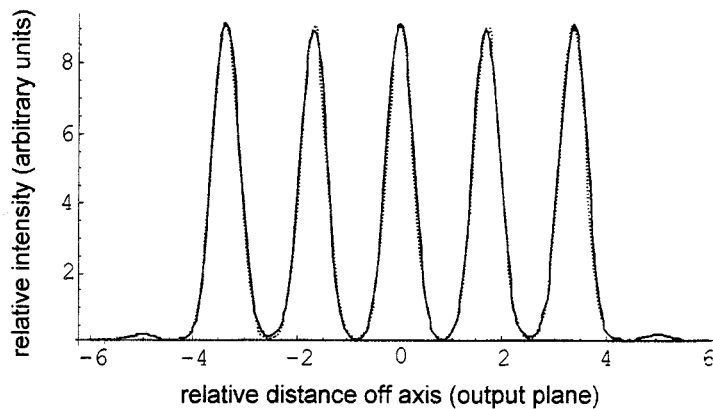

Figure 3 Array of Gaussian beams (dotted line) superimposed on DG beam array.

### Gaussian Beam Mode Analysis of Multiplexer Performance

As described in the last section the basic operation of a phase grating is understood in terms of straightforward Fourier optics. However, Gaussian beam mode analysis is a powerful tool when investigating the limitation of the grating in a real submillimeter system of finite throughput and bandwidth[14]. A serious consideration in millimetre/submillimetre-wave systems is that compact optics may result in some of the spatial frequencies in the beam being truncated in the optical train between the grating and the final output plane where an array of image beams is to be delivered. Ultimately, what one is interested in is evaluating the coupling to the horn antenna feeds of the detector array. From a multimode beam viewpoint the grating has the effect of seriously disturbing the lower order modes making up the incident quasi-Gaussian beam, thus scattering significant power into very high order modes.

Because of the Cartesian symmetry of the grating array the fields can be most conveniently expressed in terms of Hermite-Gaussian beam modes,  $\psi_{mn}$ :

$$E(x, y) = \sum_{m=0}^{\infty} \sum_{n=0}^{\infty} a_{mn} \psi_{mn}(x, y),$$

where  $\psi_{mn}(x, y)$  are given by the usual expression [16]:

$$\psi_{mn}(x, y, z) = h_m(x; W) h_n(y; W) \exp(-ik(z + (x^2 + y^2)/2R) + i\Delta\phi_{mn}),$$

with

$$h_m(s; W) = \left[ 2^m m! \sqrt{\pi W^2 / 2} \right]^{1/2} H_m(\sqrt{2}s / W) \exp(-s^2 / W^2),$$

and  $H_m$  a Hermite polynomial of order  $m$ . The beam width parameter, phase radius of curvature and phase slippage terms,  $W$ ,  $R$  and  $\Delta\phi_{mn}$ , respectively are functions of position  $z$ , which is taken to be zero at a waist (at the grating, in this instance).

Crucial to the efficiency of the Gaussian beam mode approach in analysing the system is the choice of the optimum beam mode set. We require that the array of beams scattered by the grating can be described accurately by a finite sum of as few modal contributions as possible. At first sight one might think that a large number of on-axis modes will be required to accurately describe the array of beams at the output plane, since, of course, in the absence of the grating just one on-axis beam is produced. In fact, a naïve extension of a multi-moded analysis using a beam set appropriate for a single on-axis beam can lead to computational and numerical difficulties as too many modes have to be included. However, as shown in [15] there exists a mode set of modest size in terms of which one can to a good approximation describe all of the off-axis beams with adequate sensitivity. The beam waist radius for the best choice mode set at the output plane is given by:

$$W_o^2 \approx \sqrt{\frac{A}{\pi}} \frac{W_{oh}}{N},$$

where  $A$  is the area of the array of beams at the output plane,  $W_{oh}$  is the corresponding equivalent waist width of a simple Gaussian approximation to one of the beams on the output plane and  $N$  is the maximum diffraction order of the beams that we want to describe. Thus, for a  $5 \times 5$  array with  $W_{oh} = 0.38\Delta x_o$ ,  $N = 2$ , and  $A = (5 \Delta x_o)^2$ , one obtains  $W_o = 0.73 \Delta x$ . Clearly, in order for the system to operate efficiently as a

multiplexer, the throughput of the optics (between the grating and the output plane) must be such that the highest order mode transmitted extends spatially over a region that includes all of the array of images of the feed horn in the output plane.

Having chosen the mode set, the amplitude coefficients for the source horn feed are determined by performing the relevant overlap integral at the aperture of the source feed to determine the mode coefficients:  $a_{mn} = \iint \psi_{mn}(x,y)^* E(x,y) dx dy$ . The change in the form of the beam as it propagates away from this plane is determined by the evolution of the phase slippage term  $\exp(i\Delta\phi_{mn}(z))$ . This term does not depend on  $(x,y)$  and can conveniently be included in the amplitude coefficient  $A_{mn} = a_{mn} \exp(i\Delta\phi_{mn}(z))$ .

The effect of the grating on the source beam can be understood in terms of the scattering of the power carried by the component modes into higher order modes:

$$\psi_{mn}^s = \sum_{m',n'} S_{mm',nn'} \psi_{m'n'}$$

where

$$S_{mm',nn'} = \iint dx dy \exp(i\phi(x,y)) h_m(x;W) h_n(y;W) h_{m'}(x;W) h_{n'}(y;W)$$

and the phase term has been absorbed into the amplitude coefficients. Note that  $\phi(x,y)$  represents the phase modulation introduced by the grating. The field scattered by the grating is given by:

$$E(x,y) = \sum_{mn} A_{mn} [\psi_{mn}(x,y)]^s = \sum_{mn} \sum_{m'n'} A_{mn} S_{mm',nn'} \psi_{m'n'}(x,y)$$

Thus, the new mode amplitudes for the transmitted beam are given by:

$$b_{m'n'} = \sum_{mn} S_{mm',nn'} A_{mn}$$

As the beam propagates away from the grating the phase slippage terms  $\exp(i\Delta\phi_{mn})$  further evolves. For propagation to the Fourier plane of the grating,  $\Delta\phi_{mn} = (m+n+1)\pi/2$ , so that on the output plane the amplitude coefficients are given by  $B_{mn} = i^{(m+n+1)} b_{mn}$ . However, if the optics between the grating and the output plane truncates the system of diffracted beams to any extent then some modal filtering takes place. This process can also be described in terms of the scattering of the component modes as discussed in [10].

## **Grating Bandwidth**

To evaluate the performance of a grating as a multiplexer, one can calculate the coupling efficiency of the system of image beams to a test receiver horn moved about the output plane. We can conveniently represent the beam pattern of any of the receiver array horn antennas in terms of a sum of on-axis modes, the amplitudes of the modes depending on the position of the horn on the image plane. Clearly, it is most convenient to expand the fields of the test horn antenna aperture in terms of the same mode set as is used for the array of images  $E_h = \sum c_{mn} \psi_{mn}$ . For optimum coupling to the array of image beams the phase centre of the horn should be located on the image plane, and the beam width should closely match those of the array of images. The coupling of the horn antenna to the field is then given by:  $\eta = |\sum_{mn} (B_{mn})^* C_{mn}|^2$ , where  $C_{mn} = \exp(i\Delta\phi_{mn})c_{mn}$ , takes into account the phase slippage between the horn aperture and its phase centre.

As with all binary optics the DG will only operate correctly over a finite bandwidth. This may pose a limitation for certain applications as noted in the introduction. We therefore investigated a frequency detuning of the order of 10% using Gaussian beam modes. Two effects occur if the wavelength of the LO beam is not at the design wavelength of the grating:

- (i) The actual inter-beam diffraction order separation in the output plane will change implying some of the beams will no longer couple well to the detector array as they will be misaligned with the horn centres. Realignment, however, can be achieved easily by designing some variable magnification into the LO path optics.
- (ii) The two binary phase delays for the grating are wavelength dependent, and so the grating will only produce the required phase modulation of  $\phi(x,y) = \pm 1$  at the design frequency.

These effects reduce the idealised coupling to an array of test horns both in terms of the uniformity of the intensities and the displacement of the array of image beams with wavelength. Gaussian beam mode analysis can again be applied to determine the deterioration in the power coupling characteristics for an array of test horns. The results of the analysis for a  $5 \times 5$  grating are presented in Figure 4. It is worth noting that SIS mixer sensitivity to local oscillator power for optimised performance is usually not so critical that such a variation would cause a significant deterioration in performance across the array.



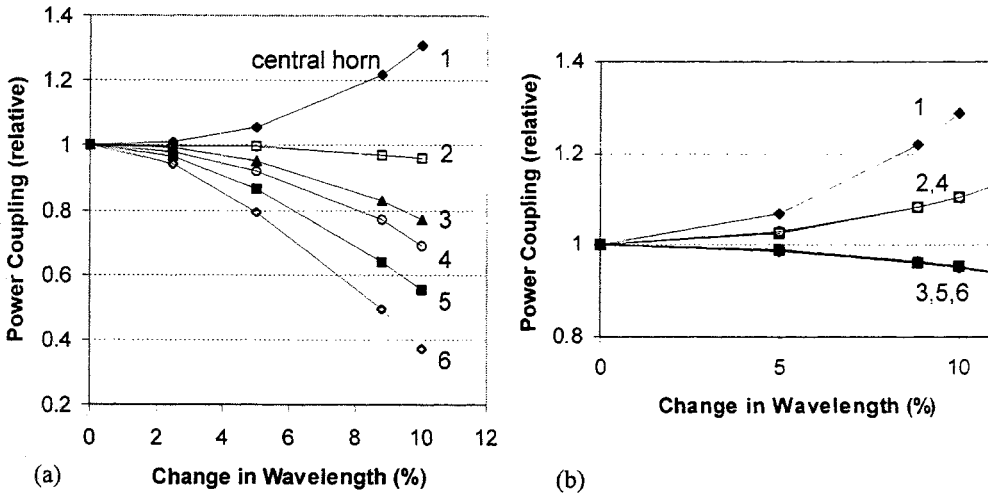
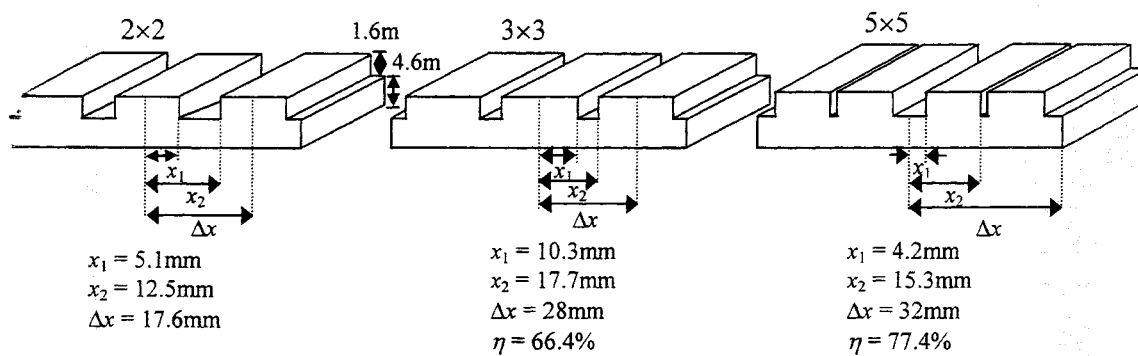

**Figure 4** Power coupling to horns at six distances from the centre of a 5x5 array (b) with and (a) without variable magnification.

### Experimental Measurements

The practical feasibility of using DGs was evaluated at Maynooth using a 100-GHz test facility. 2x2, 3x3 and 5x5 gratings were designed for use at this frequency and Figure 5 shows a cross-section along one of the axes for each grating. The gratings were manufactured from 112mmx112mm slabs of fused quartz by the Lithuanian optics company, Eksma.

The DGs were tested using the Fourier 4-f set-up shown in Figure 6. A 100-GHz Gunn oscillator was used with a conical horn-antenna feed as the source. The horn phase centre was placed at the focal point of an off-axis ellipsoidal mirror, M1, with an angle-of throw of 45°. The gratings were mounted on a perspex holder at the common focal point of the two mirrors M1 and M2 where the source beam had a waist. The mirror M2 was used to image the output of the grating onto the detector plane. The crystal detector was mounted on a computer-controlled XY raster-scanner centred on the focal point of M2. The scanner was capable of covering an area of 550mm x 550mm with a step resolution of 0.03mm. Eccosorb was used to avoid unwanted reflections from component mountings.



**Figure 5** Designs for 2x2, 3x3 and 5x5 DGs. Designs for the 3x3 and 5x5 gratings were based on the calculations of Dammann & Klotz [5]. 6x6 grating periods were used in the 2x2 grating, and 4x4 periods in the other two. The efficiencies,  $\eta$ , refer to the 1-dimensional case. (The tolerance on each dimension was  $\pm 0.1$ mm).

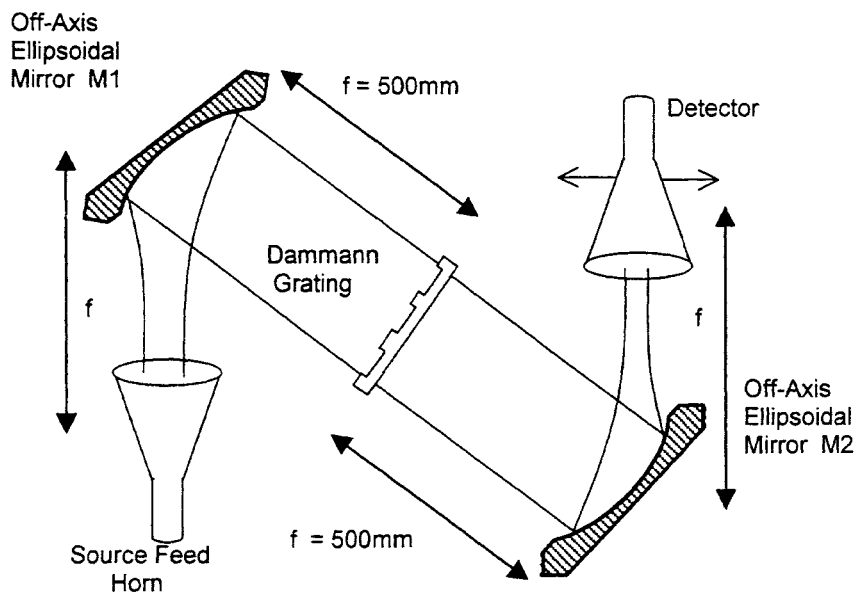

**Figure 6** 4-f set-up to test the Damann gratings.

The beam patterns obtained with the three gratings are presented in Figure 7. These are to be compared with the theoretical patterns predicted using the Gaussian beam mode analysis discussed previously and shown in Figure 8.

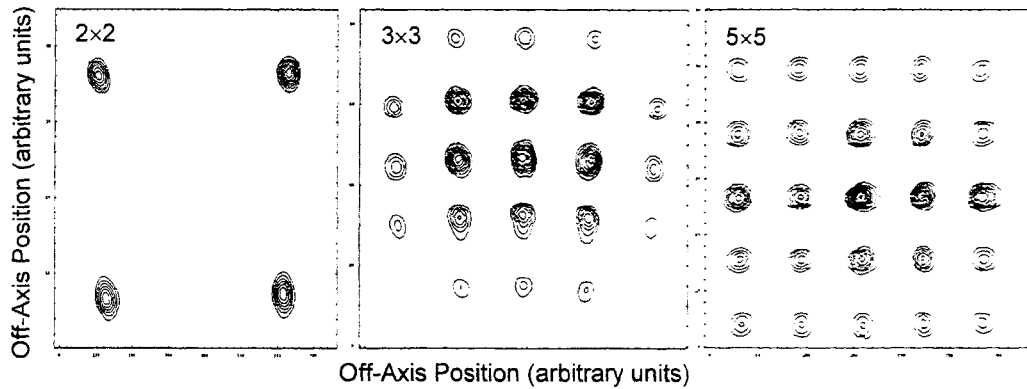

Figure 7 Output intensity patterns obtained with the 2x2, 3x3 and 5x5 gratings (contours are linear)

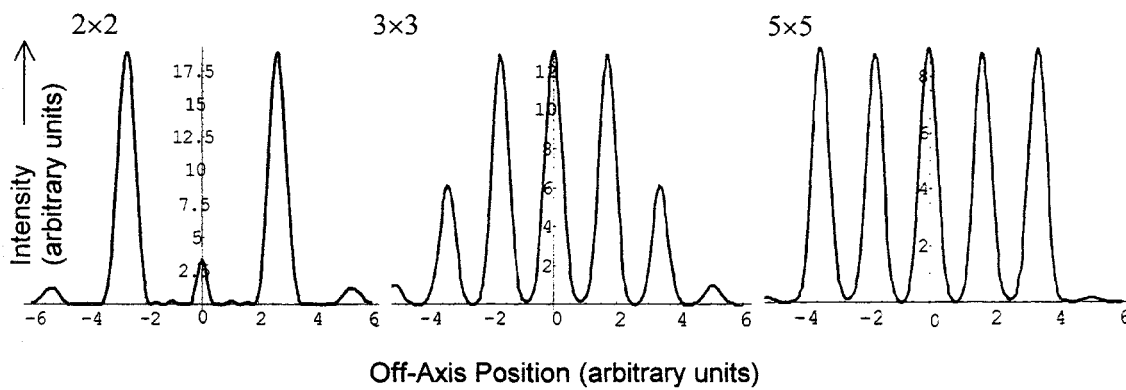

Figure 8 Cross section of the expected beam pattern from the 2x2, 3x3 and 5x5 gratings

In all cases a 2-dimensional grid of beams is obtained. The long focal length of our mirrors meant that the beam waist at the grating was  $\sim 2\Delta x$ . From the previous discussion, the predicted beam-separation to beamwidth ratio at the output plane is then  $\sim 3:1$ , in agreement with what was found. For our particular choice of 3x3 grating both the theoretical and experimental plots show that the next highest order diffraction peaks are not completely suppressed. The output grid spacings are as expected for a square array reflected through  $45^\circ$  by an ellipsoidal mirror. The overall efficiency of the 2x2 and 5x5 gratings is higher and in these cases the central grid of peaks is far more intense than the higher orders. In practice we found that for the 5x5 array, the bottom row of 5 beams was consistently of a lower intensity than the other four rows,

this we attribute to the fact that our mirrors were not large enough to cover the entire output beam pattern. For the  $5 \times 5$  measurements, therefore, we replaced the mirrors M1 and M2 in Figure 6 with HDPE lenses ( $f = 250\text{mm}$ ).

In order to investigate the bandwidth limitation of DGs, the 100-GHz Gunn diode was replaced with one whose frequency could be varied over the range 90 – 105 GHz and the measurements repeated.

Measurements on the  $3 \times 3$  grating at 90.4 GHz are presented along with the theoretical prediction in Figure 9. As expected the inter-beam spacing increases by a factor of  $\Delta\lambda/\lambda_0$  and the intensity of the central beam increases at the expense of the other eight.

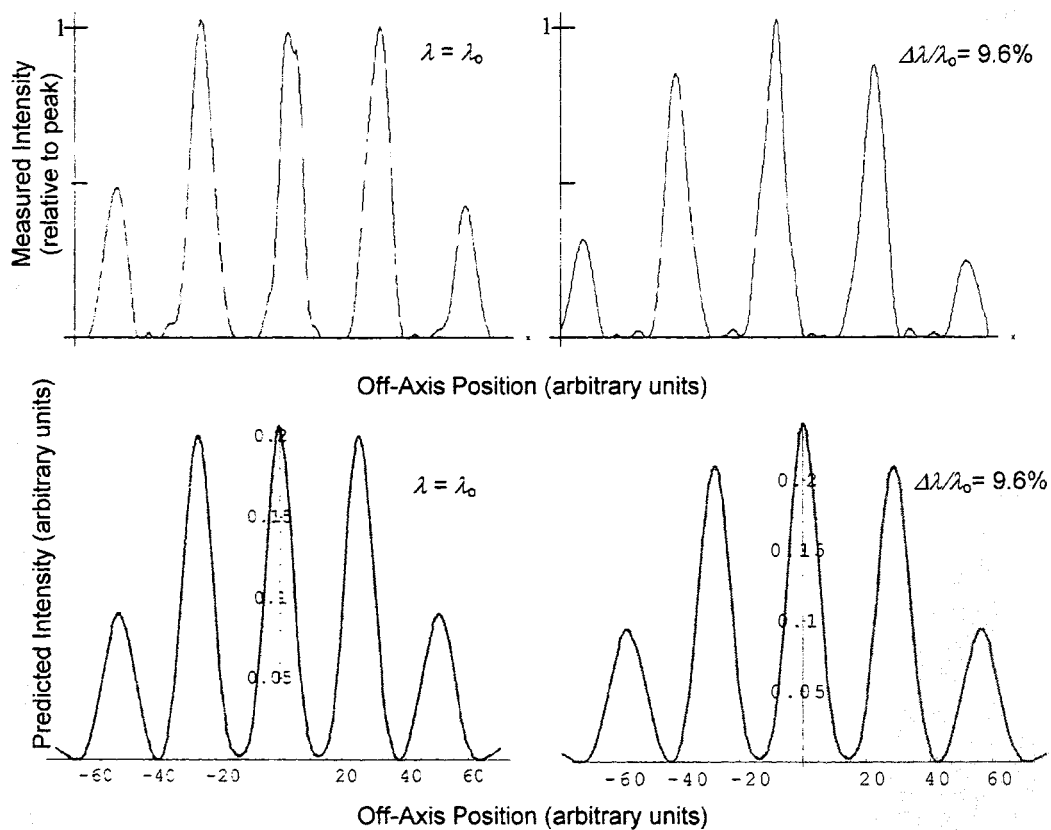

**Figure 9** Cross-section of the measured and predicted beam patterns from the  $3 \times 3$  grating. The output for the design wavelength and a 9.6% detuning are shown. Calculations were made using the Gaussian beam mode analysis discussed in this paper.

The uniformity of the  $2 \times 2$  and  $5 \times 5$  beam patterns was also found to remain high over the bandwidth investigated. Figure 10 shows the output from the  $5 \times 5$  grating at  $\Delta\lambda/\lambda_0 = 5\%$ .

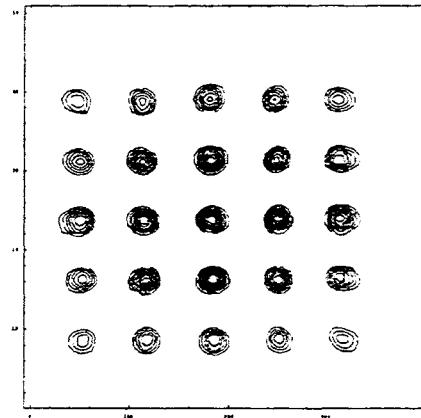

**Figure 10** Output intensity patterns (linear contours) obtained with the  $5 \times 5$  grating at 95.2 GHz.

## Conclusions

In this paper we have presented a study of the feasibility of using Dammann gratings for beam multiplexing at millimeter and submillimeter wavelengths. We have shown from a theoretical study that at the design wavelength we get good diffraction efficiencies of around 60% for a  $5 \times 5$  array, with the missing power being channelled into higher diffraction orders which can easily be terminated.

The theoretical bandwidth of such a grating would be of the order of 15%, which is typical of astronomical array receivers operating in the submillimeter waveband.

In the case of the astronomical receiver, an LO multiplexing scheme would work best for the case where mixer characteristics are very similar, so that the LO requirement of individual mixers is the same. The scheme is particularly suitable for sparse arrays.

We also investigated the practical feasibility of producing a  $2 \times 2$ ,  $3 \times 3$  and  $5 \times 5$  grating at submillimeter wavelengths for the scenario referred to above, and presented measurements of a prototype grating.

Since with the transmission grating there may be some reflection loss, we are also looking into reflection grating designs. These would have to be operated off-axis to prevent beam vignetting.

## Acknowledgements

The authors would like to thank Forbairt (The Irish Science and Technology Board) and the Board of the JCMT for financial support of this project.

## References

- [1] Klein T., Ediss G.A., Gusten R., Hauschildt H. & Kasemann C., "LO beam array generation at 480GHz by use of phase gratings," *Eighth International Symposium on Space Terahertz Technology*, Harvard, 1997
- [2] Graf U.U., Haas S., Honingh C. E., Jacobs K., Schieder R. & Stutzki J., "Array receiver development at KOSMA for the sub-millimeter and terahertz spectral range", in *Advanced Technology Millimetre Wave, Radio and Terahertz Telescopes*, Thomas G. Phillips, Editor, Proceedings of SPIE Vol. 3357, 159-166 (1998)
- [3] Gusten et al, "CHAMP: The carbon heterodyne array of the MPIfR," in *Advanced Technology Millimetre Wave, Radio and Terahertz Telescopes*, Thomas G. Phillips, Editor, Proceedings of SPIE Vol. 3357, 167-177 (1998)
- [4] Belousov V.I., Denisov G.G. and Peskov N. Yu., "Quasi-optical multiplexing based on reflecting diffraction grating," *Int. J. IR & MM Waves*, 12, 1035, 1991
- [5] Dammann H. and Klotz E., "Coherent optical generation and inspection of two-dimensional periodic structure," *Optica Acta*, 24, 505, 1977
- [6] Jahns J., Downes M.M., Prise E.M., Streibl N. and Walker S.J., "Dammann gratings for laser beam shaping," *Optical Engineering*, 28, 1267, 1989
- [7] J.A. Murphy, S. Withington & H. van de Stadt, "Dammann Gratings for Local Oscillator Beam multiplexing," in *Multi-feed Systems for Radio Telescopes*, (ed. D.T.Emerson and J.M. Payne) A.S.P. Conf. Ser. Vol. 75, (1995)
- [8] J.A. Murphy, S. Withington and M. Heanue, "Local oscillator splitting using Dammann phase gratings," *Proceedings of the 3rd International Workshop on Terahertz Electronics*, Zermatt, Switzerland, (Sept. 1995)
- [9] J.A. Murphy, M. McCabe and S. Withington, "Gaussian beam mode analysis of the coupling of power between horn antennas," *International Journal of Infrared & Millimeter Waves*, vol. 18, 501 (1997)
- [10] J.A. Murphy, S. Withington & A. Egan, "Mode conversion at diffracting apertures in millimetre and submillimetre-wave optical systems," *IEEE Trans. Microwave Theory and Techniques*, vol.41, 1700-1702 (1993)
- [11] Goodman J.W., *Introduction to Fourier Optics*, McGraw Hill, New York, 1968
- [12] Morrison R.L. 1992, *J. Opt. Soc. Am. A*, 9, 464
- [13] S. Withington & J.A. Murphy, "Analysis of diagonal horns through Gaussian-Hermite modes," *IEEE Trans. Antennas & Propagation*, 40, 198-206 (1992)
- [14] S. Withington. & J.A. Murphy, "Modal Analysis of Partially Coherent Submillimetre-wave Quasi-optical Systems." *IEEE Trans. Antennas & Propagation*, vol. 46, 1650-1658, 1998
- [15] J.A. Murphy & S. Withington, "Gaussian-beam-mode analysis of multibeam quasi-optical systems," in *Advanced Technology Millimetre Wave, Radio and Terahertz Telescopes*, Thomas G. Phillips, Editor, Proceedings of SPIE Vol. 3357, 97-104 (1998)
- [16] Goldsmith P.F., "Quasi-optical techniques at millimeter and submillimeter wavelengths", in *Infrared and Millimeter Waves*, 8, 227, 1982