

The Genetic Architecture of Ecological Speciation and the Association with Signatures of Selection in Natural Lake Whitefish (*Coregonus* sp. Salmonidae) Species Pairs

S. M. Rogers¹ and L. Bernatchez

Québec Océan, Département de Biologie, Université Laval, Ste-Foy, Québec, Canada

Adaptive evolutionary change is contingent on variation and selection; thus, understanding adaptive divergence and ultimately speciation requires information on both the genetic basis of adaptive traits as well as an understanding of the role of divergent natural selection on those traits. The lake whitefish (*Coregonus clupeaformis*) consists of several sympatric “dwarf” (limnetic) and normal (benthic) species pairs that co-inhabit northern postglacial lakes. These young species pairs have evolved independently and display parallelism in life history, behavioral, and morphological divergence associated with the use of distinct trophic resources. We identified phenotype–environment associations and determined the genetic architecture and the role of selection modulating population genetic divergence in sympatric dwarf and normal lake whitefish. The genetic architecture of 9 adaptive traits was analyzed in 2 hybrid backcrosses individually phenotyped throughout their life history. Significant quantitative trait loci (QTL) were associated with swimming behavior (habitat selection and predator avoidance), growth rate, morphology (condition factor and gill rakers), and life history (onset of maturity and fecundity). Genome scans among 4 natural sympatric pairs, using loci segregating in the map, revealed a signature of selection for 24 loci. Loci exhibiting a signature of selection were associated with QTL relative to other regions of the genome more often than expected by chance alone. Two parallel QTL outliers for growth and condition factor exhibited segregation distortion in both mapping families, supporting the hypothesis that adaptive divergence contributing to parallel reductions of gene flow among natural populations may cause genetic incompatibilities. Overall, these findings offer evidence that the genetic architecture of ecological speciation is associated with signatures of selection in nature, providing strong support for the hypothesis that divergent natural selection is currently maintaining adaptive differentiation and promoting ecological speciation in lake whitefish species pairs.

Introduction

According to the ecological theory of adaptive radiation, organisms are the product of their environment and the resources they consume (Schluter 2000). Under this predictive framework, shifts of organisms into novel habitats are hypothesized to be adaptive, whereby populations should diverge at phenotypes that influence survival and reproduction when exposed to different environments (Mayr 1963). Although it is generally accepted that the primary mechanism of adaptive evolution is directional selection, demonstrating and explaining the role of selection in cases of adaptive divergence have been challenging (Reeve and Sherman 1993; Rieseberg et al. 2002). This challenge lies principally with establishing a link between the role of selection on phenotypic divergence and the heritable basis of adaptive traits. This implies deciphering the number and distribution of genes that affect traits leading to adaptive divergence, as well as understanding the biological link between the underlying variation for genetically based phenotype–environment associations and the action of natural selection on those traits (Schluter 2000; Ungerer and Rieseberg 2003).

Surprisingly little is known about the genetic basis of adaptation and the role of selection, such that the number and magnitude of genetic changes responsible for speciation are far from resolved (Orr and Smith 1998; Orr

2005b). Adaptation of populations toward an optimum fitness within a new environment may be associated with several genes, each of small effect, or may invoke fewer genes with larger phenotypic effects that are more apt to respond to selection rapidly (Orr 2005a). In either scenario, understanding the response of traits to selection is required to demonstrate that the mechanism invoking divergence is adaptive (Schemske and Bradshaw 1999). Until recently, adaptive trait divergence and its role in the formation of reproductive isolation have been debated largely in the absence of empirical data (Bradshaw et al. 1998; Jones 1998; Kim and Rieseberg 1999; Sawamura et al. 2000; Peichel et al. 2001; Albertson et al. 2003). The most striking feature from these studies is the lack of consistency between species as well as the tremendous amount of variation with respect to the number of genes influencing species differences (Orr 2001). Despite these contrasting views, a general consensus has persisted that the consequence of adaptive trait divergence is the formation of reproductive isolation through pleiotropic interactions or physical linkage as a by-product of natural selection from populations adapting to divergent environments (Rice and Hostert 1993; Hawthorne and Via 2001; Presgraves et al. 2003). This is central to the ecological speciation hypothesis (Dobzhansky 1951; Rundle and Nosil 2005). However, little is known about the genetic architecture of adaptive traits, the evolutionary forces that may have driven their divergence, or the consequences of adaptive divergence and how this process may contribute to the formation of reproductive barriers (Barbash et al. 2004; Rogers and Bernatchez 2006). Ultimately, more information about the genes underlying species differences is needed to address these issues (Orr 2001; Coyne and Orr 2004).

There are 2 main approaches that may be used toward achieving these objectives. First, recent studies have

¹ Present address: Department of Zoology, University of British Columbia, Vancouver, British Columbia, Canada

Key words: speciation, QTL, linkage, natural selection, coregonus, genome scan.

E-mail: srogers@zoology.ubc.ca.

Mol. Biol. Evol. 24(6):1423–1438. 2007

doi:10.1093/molbev/msm066

Advance Access publication April 2, 2007

applied a “bottom-up” approach targeting specific candidate genes. This approach starts with the genes and investigates how their expression affects the average phenotype, thus demonstrating the influence of selection on adaptive trait divergence by characterizing candidate genes (Feder and Mitchell-Olds 2003). However, adaptation is, by nature, a multifaceted phenomenon where many traits evolve together (Wallace 1953; Powers et al. 1991; Reeve and Sherman 1993). Fisher’s geometric model of adaptation even assumes that every mutation has a pleiotropic effect on fitness (Orr 2005a). As such, a bottom-up approach risks missing the most relevant candidate genes and may hamper explanations of adaptive divergence in cases where many traits coevolve together. A “top-down” approach of explaining adaptive divergence may be more effective, particularly in nonmodel organisms, where the biology of adaptive traits may not be well defined or genomic tools may be limited. This approach should be the first to identify phenotype–environment associations and then attempt to understand the genetic architecture underlying the evolution of the traits. Finally, the role of selection in modulating population genetic divergence underlying adaptive traits needs to be determined.

Understanding the genetics of adaptation is possible through quantitative trait loci (QTL) studies, which are dependent upon the prediction that the genetic architecture of adaptation can be explained by the number, magnitude, and direction of QTL underlying adaptive phenotypes (Orr and Coyne 1992). QTL cannot always predict the action of selection in nature (Orr 1998; Gardner and Latta 2006). For example, allelic covariance among genes may potentially restrict the possibility of detecting the effect of selection for QTL of small effect (Le Corre and Kremer 2003). However, divergent selection is ultimately predicted to reduce gene flow at QTL implicated in adaptation and speciation. In these cases, QTL that exhibit outlier patterns of differentiation when compared with neutral expectations are likely to represent adaptive QTL under the influence of divergent selection maintaining differences between species (e.g., Luikart et al. 2003; Beaumont and Balding 2004; Campbell and Bernatchez 2004; Scotti-Saintagne et al. 2004; Rogers and Bernatchez 2005; Bonin et al. 2006). The amenability of genome scans also lends to the possibility of identifying parallel trends of divergence through analysis of multiple populations. Parallel trends of divergence offer stronger support for the role of natural selection in adaptive trait evolution as other evolutionary forces, such as genetic drift, are unlikely to produce predictable changes in independent lineages in correlation with the environment (Schluter and Nagel 1995).

The lake whitefish (*Coregonus clupeaformis*) species complex is a dynamic example of evolutionary change ideal for studies of adaptive divergence. Isolation during the Pleistocene led to significant allopatric divergence between populations inhabiting distinct glacial refugia (18,000 to 500,000 years ago; Bernatchez and Dodson 1990). Secondary contact of glacial races subsequently occurred in several northern temperate postglacial lakes (Pigeon et al. 1997). Ecological opportunity within these lakes (e.g., the absence of competitors; Bernatchez 2004) as well as character displacement has contributed to the recent parallel evolution

and reproductive isolation of a “dwarf” ecotype diverging in sympatry with the normal ecotype to exploit limnetic and benthic niches of the lakes, respectively (Pigeon et al. 1997; Rogers and Bernatchez 2006). These sympatric dwarf (limnetic) and normal (benthic) whitefish species pairs now co-inhabit in at least 6 lakes in Maine, USA, and Québec, Canada (Bernatchez and Dodson 1990). Within these environments, dwarf whitefish mature as early as 1 year old and seldom exceed 20 cm in length and 100 g in weight, whereas normal whitefish mature at an older age (greater than 2 years old) and commonly exceed 40 cm and 1,000 g. Dwarf whitefish are found only in sympatry with the normal ecotype and only in the absence of another limnetic coregonine fish, the cisco (*Coregonus artedii*), suggesting that divergent natural selection resulting from ecological pressures within the limnetic niche may explain the evolution of the derived dwarf whitefish (Pigeon et al. 1997). The dwarf and normal dichotomy is further supported by several genetically based phenotype–environment associations (Bernatchez 2004). Adaptive trait differences have been observed for behavior (associated with habitat isolation and predator avoidance; Rogers et al. 2002), growth (associated with the physiological cost of inhabiting a limnetic environment; Trudel et al. 2001; Rogers and Bernatchez 2005), and morphology (associated with gill raker–prey associations, where more rakers in the buccal cavity of fish within the limnetic niche are more efficient to sieve ingested prey). Divergence in allopatry has led to the formation of intrinsic reproductive isolation between species pairs following experimental evidence of increased hybrid inviability (Lu and Bernatchez 1998; Rogers and Bernatchez 2006). Moreover, the evidence for several phenotype–environment associations as well as divergent levels of transcription at genes associated with swimming capacity and energetic metabolism (Derome et al. 2006) indicates that both intrinsic (genetic) and extrinsic (ecological) forces are contributing to the phenotypic evolution of dwarf and normal lake whitefish.

The objective of this study was to elucidate the genetic architecture of adaptive divergence in dwarf and normal lake whitefish and to test if differences at QTL were maintained by selection among natural populations. We hypothesized that the genetic basis of adaptive trait divergence and reproductive isolation could be understood as the genetic architecture of behavioral, physiological, morphological, and life history traits that differentiate dwarf and normal species pairs. We localized at least one QTL for each of these adaptive traits. Using a genome scan approach, we then tested if any of these QTL were responding to selection among naturally occurring sympatric species pairs. We found that several of these QTL were concurrently under selection in diverging species pairs, offering evidence that divergent natural selection modulates the genetic architecture of adaptive divergence and ultimately promotes ecological speciation.

Materials and Methods

As their postglacial divergence is recent, fertile hybrids between dwarf and normal whitefish can be generated

in the laboratory, allowing the construction of genetic linkage maps for the dissection of complex traits (Rogers et al. 2001). We combined a QTL mapping and map-based genome scan approach toward identifying genomic regions implicated with 9 phenotype–environment associations involved in dwarf and normal whitefish divergence. We used map-based loci where homology among natural populations could be inferred to screen for outlier levels of differentiation compared with neutrality across 4 of the 6 sympatric species pairs of whitefish found in the St John River watershed in order to test the hypothesis that divergent selection at QTL is maintaining adaptive divergence between dwarf and normal species pairs in each lake.

Experimental Families

Hybrids were produced between parents representing 2 allopatric whitefish populations belonging to different glacial races. The parental generation of the Acadian glacial origin (dwarf) and Atlantic-Mississippian glacial origin (Normal) was sampled from Témiscouata Lake (47°36'N, 68°45'W) and Aylmer Lake (45°50'N, 71°26'W), respectively. These particular populations were chosen because they overlap in reproductive schedule, rendering hybrid crosses possible between them. The F1 consisted of pure dwarf, pure normal, and their hybrids (Lu and Bernatchez 1998). Two distinct backcross-like crosses were used for mapping: 1) between a ♀ Hybrid (♀ Normal × ♂ dwarf) and a ♂ dwarf, denoted as Hybrid × dwarf, and 2) between a ♀ Hybrid (♀ dwarf × ♂ Normal) and a ♂ Normal, denoted as Hybrid × Normal. The experimental design of utilizing outbred F1 hybrid females backcrossed to pure parental dwarf and normal resulted in 2 families with genetic backgrounds derived primarily from each population. Both families were reared in the same units under photoperiod and temperature conditions mimicking natural lake conditions from embryonic development until maturity. At the age of 1+ (September 2001), 250 individuals from each family were surgically implanted with passively integrated transponder (PIT) tags providing a barcode by which each individual could be followed throughout their life history. At this time, adipose fin tissue was sampled for DNA analyses.

Phenotypic Experiments among Families

Swimming Behavior

Divergent behaviors are often important traits to understand if one wishes to understand the genetics of ecological divergence. Swimming behaviors are essential to understanding lake whitefish evolution following evidence that they comprised genetically based phenotype–environment associations in the parental source populations (Rogers et al. 2002). Behavior experiments commenced in October 2001 and were performed in two 4,500 l cylindrical aquaria. These experimental trials followed the methodology of Rogers et al. (2002), with the exception that these experiment trials were conducted on individual fish. Each day, a single fish was randomly selected from the rearing tanks, its PIT tag scanned, and then transferred to the ex-

perimental tank and allowed to acclimate for 60 min. Only one fish per rearing tank was sampled per day to reduce the chances of incidental bias from disturbing the remaining fish in the rearing tanks. Thus, with 2 rearing tanks per family, up to 4 individuals were studied daily. Video cameras recorded behavioral observations for 30 min per fish with no one inside the room during the trials. Four behavioral phenotypes with the following sample sizes in each family were subsequently quantified from the videos for QTL analyses: depth selection (Hybrid × dwarf, $n = 109$; Hybrid × Normal, $n = 76$), directional changes (Hybrid × dwarf, $n = 95$; Hybrid × Normal, $n = 76$), burst swimming (Hybrid × dwarf, $n = 95$; Hybrid × Normal, $n = 76$), and activity (Hybrid × dwarf, $n = 109$; Hybrid × Normal, $n = 76$).

Depth selection was defined as the observed distance of each fish in the water column from the bottom of the tank and was measured by sectioning the experimental tank into 5-cm increments (up to 200 cm) whereupon the position of the fish could be recorded to the nearest 5-cm increment. One observation per minute was recorded resulting in 20–30 observations for each fish per trial. The phenotype was then the average of these 20–30 observations. Directional changes were defined as single immediate turns greater than 90°. Burst swimming was defined as the number of instantaneous accelerations invoking a short, strong use of the caudal fin to increase speed. Activity, the degree to which fish utilized different positions of the water column during the trial, was calculated as the coefficient of variation (standard deviation of the depth measurements divided by the mean depth observed). For both burst swimming and directional changes, 5 observations per fish recorded the number of times these behaviors were observed during 1-min intervals. The phenotype was then the average of these 5 observations.

Growth

Growth experiments were performed following the completion of the behavioral trials. Each month for a period of 6 months (July 2002 to December 2002), a total of 336 fish (Hybrid × dwarf, $n = 198$; Hybrid × Normal, $n = 138$) were anaesthetized with 0.001% Eugenol solution whereupon length and body weight were measured. During each measurement, biomass densities among tanks were equilibrated (≤ 20 g/l), and food rations were adjusted to maintain feeding at 0.8% body mass per day for all groups. Successive body weight measurements permitted the calculation of individual absolute growth rates and determination of the temporal period that yielded the highest rate of growth for QTL phenotypes.

Morphology

In January 2003 (age 2+), 239 fish (Hybrid × dwarf, $n = 143$; Hybrid × Normal, $n = 96$) were euthanized by pithing the brain (in concordance with Canadian Council on Animal Care, 2005) following an initial anesthetic (0.001% Eugenol). Digital images, length, and weight were recorded to measure the condition factor ($\text{weight}/\text{length}^3$), a ratio classically employed to assess if fish are slender (condition factor < 1) or robust (condition factor > 1),

and to assess the health of fish in captivity (whereby a drop in condition factor over time may indicate chronic stress through lack of feeding) (Iwama 1996). For the gill raker phenotypes, the left primary gill arch was removed and the number of upper and lower gill rakers was counted for each individual. The phenotype was the total number of gill rakers.

Life History

Each fish was dissected to establish the sex as well as the stage of sexual maturation for females. The gonadosomatic index was measured as weight of gonads (g)/total wet weight of fish (g) \times 100. The stage of female maturity was inferred from the Hjort (1914) maturity index. This index consisted of the following 7 stages based on specific gross anatomical criteria: (stage 1) immature fish with very small sexual organs close to or under the vertebral column and eggs are invisible; (stage 2) initial stage of maturation where ovaries are longer than half the ventral cavity and eggs begin to be visible to the naked eye; (stage 3) development with swelling, tube-like ovaries occupying about half the ventral cavity, and eggs definitely visible to naked eye; (stage 4) maturing with ovaries filling nearly full length of ventral cavity, eggs still translucent/opaque; and (stage 5) maturation with ovaries bulging, filling the ventral cavity, and containing large transparent eggs. At this stage, under ventral body pressure, eggs will expel from the body cavity, and (stage 6/7—quantified as 1 stage) ripe/spent roe running from body, and fish are fully mature or visibly spent with only remnant eggs remaining in the body cavity.

QTL Mapping

All methods and results relevant to the construction and organization of the genetic maps are detailed elsewhere (Rogers and Bernatchez 2007). Briefly, sex-specific marker segregating in the backcross families was assigned to a linkage group under a log of odds (LOD) of 4, whereas orders and recombination distances of these groups were determined under the Kosambi mapping function independently for both families using MAPMAKER/EXP (Lander et al. 1987). Defining sex-specific linkage groups was preferable as salmonid fishes are known to exhibit significant sex-specific recombination between male and female gametes, due to tetraivalent formations in the males during meiosis (Sakamoto et al. 1999; Gharbi et al. 2006). The Hybrid \times dwarf map has a total of 389 amplified fragment length polymorphisms (AFLP) and 23 microsatellites covering a total of 37 linkage groups, including 34 females linkage groups (average = 8.0 loci per linkage group, average distance between markers = 17.3 cM, and a total map length of 2,800 cM) and 14 dwarf male linkage groups (average = 8.7 loci per linkage group, average distance between markers = 17.96 cM, and a total map length of 2,127.5 cM). The Hybrid \times Normal map consisted of 452 AFLP and 14 microsatellites covering 41 linkage groups, including 23 hybrid females linkage groups (average = 8.2 loci per linkage group, average distance between markers = 16.9 cM, and a total map length of 2,383 cM) and 29 dwarf

male linkage groups (average = 8.1 loci per linkage group, average distance between markers = 16.9 cM, and a total map length of 3198.9 cM). The homology of these mapped loci between the backcross families supported the existence of 34 linkage groups (of the 40n expected) and exhibits 83% colinearity among linked loci (Rogers et al. 2007).

All phenotypes were first tested for normality using a Kolmogorov–Smirnov test in STATISTICA (Statsoft, Inc.). Square root transformations were used for the burst swimming, directional change, gill raker counts, and the onset of maturity phenotypes. A maximum-likelihood QTL interval analysis was performed in QTL CARTOGRAPHER (Basten et al. 2002). This analysis estimated the likelihood of QTL from linked marker intervals spanning 2 cM along each linkage group. Experiment-wise significance thresholds for QTL identification were determined by permutation analysis (Doerge and Churchill 1996), which randomly permutes the phenotypic data over samples and recalculates the LOD test statistic across all mapping intervals. The most extreme LOD value from each permutation was saved and used to generate a distribution of LOD values to which empirical data could then be compared (Doerge and Churchill 1996). One thousand permutations were performed for each trait with thresholds set to maintain a 1% (highly significant), 5% (significant), and 10% (trend of an association) experiment-wise error rate. The significance of each QTL locus detected in the interval analysis was also tested with an *F* statistic in a single marker analysis (Basten et al. 2002). To determine if significant QTL overlapped on the map, 1.5-LOD support units were calculated from the most likely position of significant QTL (Boyartchuk et al. 2001).

Genome Scan of Mapped Loci in Natural Populations

The possible role of selection driving divergence of QTLs between dwarf and normal species pairs was tested by comparing patterns of genetic differentiation (F_{ST}) for the mapped loci among 4 sympatric species pairs of lake whitefish that have evolved independently (Rogers and Bernatchez 2006). A total of 440 polymorphic AFLP loci amplified from the same selective primer combinations as employed in the linkage map were available for this study (Campbell and Bernatchez 2004). Homology between QTL and loci among natural populations was inferred when loci from the same selective primer combinations yielded markers of the same molecular weight among populations (within ± 0.3 bp; Rogers and Bernatchez 2005). F_{ST} was estimated between dwarf and normal species pairs for all these homologous loci among the 4 lakes that segregated onto the genetic map. Differentiation at these loci was estimated from the F_{ST} of Nei (1977) after Nei and Chesser (1983), as described in Campbell and Bernatchez (2004). Because AFLP loci are dominant, allelic frequencies were estimated assuming Hardy–Weinberg Equilibrium (HWE) from the equation $f_p = 1 - \sqrt{(N - P)/N}$, where f_p is the frequency of the dominant allele, N is the sample size, and P is the number of individuals with the band. HWE assumption was supported by the equilibrium observed for microsatellites. As the outcome of directional selection is to generate outlier F_{ST} values relative to neutral expectations, the most

likely loci in the map under the effect of selection were established from thresholds based on the expected level of differentiation under neutrality within each lake. The value of this significance threshold was determined from simulations performed under a neutral model of evolution implementing an algorithm for dominant loci (Campbell and Bernatchez 2004). The 95% quantile of this expected distribution of F_{ST} differentiation under neutrality was employed as the significance threshold to infer QTL under divergent selection (i.e., when F_{ST} estimates >95% quantile). Thus, loci were deemed potentially under the effect of divergent selection when there was less than 5% chance of observing corresponding F_{ST} estimates under neutrality. This approach is analogous to the approach proposed by Beaumont and Balding (2004). Given the L-shaped distribution observed in both empirical and simulated F_{ST} values, no systematic attempt was made to assess loci potentially under the effect of balancing selection (Beaumont and Balding 2004).

Results

Phenotypic Comparisons

All phenotypic comparisons between the 2 hybrid backcrosses supported the underlying hypothesis that the genetic basis of adaptive traits measured in this study was at least partly additive. First, at least one significant QTL was detected for each trait with the exception of the GSI (see below). Also, we consistently found that the direction of phenotypic effect in backcross families (with $\frac{3}{4}$ of its background inherited from a given parental form) was more similar to the crossed parental ecotype than the other form (fig. 1) but intermediate with respect to the variation observed in parents (see Rogers et al. 2002; Rogers and Bernatchez 2005).

Behavior

Swimming behavior experiments (depth selection, directional changes, and burst swims) recording individual phenotypes in both families revealed that the Hybrid \times dwarf family maintained a position significantly closer to the surface (analysis of variance [ANOVA], $F = 16.25$, $P < 0.001$) (mean = 110.1 cm, range = 18–188 cm) when compared with the Hybrid \times Normal family (mean = 83.3 cm, range = 12–189 cm) (fig. 1a). Both the Hybrid \times dwarf and Hybrid \times Normal changed direction spontaneously with the Hybrid \times dwarf performing significantly more directional changes per minute (mean = 0.94, range = 0–3.2) than the Hybrid \times Normal ($N = 76$, mean = 2.0, range = 0–2.4) (ANOVA, $F = 15.21$, $P < 0.0001$) (fig. 1b). The Hybrid \times dwarf family also exhibited significantly more burst swims (average = 1.01, range = 0–3.4) when compared with the Hybrid \times Normal family ($N = 76$, mean = 0.4, range = 0–1.8) (ANOVA, $F = 41.78$, $P < 0.0001$) (fig. 1c). No significant difference between families (ANOVA, $F = 2.70$, $P = 0.10$) was observed for activity levels with the Hybrid \times dwarf family ($N = 109$, mean = 42, range = 7.5–94.4) exhibiting a slightly lower overall activity than the Hybrid \times Normal family ($N = 95$, mean = 48.5, range = 8.1–98.8) (fig. 1d).

Growth

Growth experiments performed on the same tagged individuals as in the behavioral experiments found that hybrid backcross families exhibited the highest rate of absolute growth from July to August, consistent with the growth rates observed for whitefish in nature. In the Hybrid \times dwarf family, absolute growth rate (mean = 0.43 g/day, range = 0.01–1.52 g/day) was significantly lower than that of the Hybrid \times Normal (mean = 1.29 g/day, range = 0.22–4.67 g/day) (ANOVA, $F = 330.52$, $P < 0.0001$) (fig. 1e). Consequently, Hybrid \times Normal fish weighed on average 1.8 times (mean = 285.6 g) more than the Hybrid \times dwarf family (mean = 156.9 g), leading to a strong dichotomy in size for the same age between the backcrossed families for this period of growth. Upon sacrificing all fish at the end of the experiment (age 2+), the Hybrid \times Normal family had grown to an average size (mean = 445.5 g, $\sigma = 114.9$ g) that was over twice at large as that of the Hybrid \times dwarf family (mean = 220.8 g, $\sigma = 53.8$ g).

Morphology

The condition factor of Hybrid \times dwarf individuals (mean = 1.17, range = 0.6–1.9) was significantly smaller than that of the Hybrid \times Normal individuals (mean = 1.48, range = 0.87–2.08) (ANOVA, $F = 371.65$, $P < 0.0001$). In terms of rearing conditions, however, this indicated that all fish in both families were of a healthy weight for their size (condition factor > 1; Iwama 1996). In terms of morphology, it also indicated that the Hybrid \times dwarf individuals were more slender than the Hybrid \times Normal (fig. 1e). In the Hybrid \times dwarf family, significantly more gill rakers were present ($N = 143$, mean = 23.02, range = 18–27) than in the Hybrid \times Normal family ($N = 96$, mean = 22.23, range = 19–24) (ANOVA, $F = 22.9$, $P < 0.0001$) (fig. 1f).

Life History Phenotypes

We observed a sex ratio of 68 females to 72 males (0.94:1) upon dissection of the Hybrid \times dwarf family. Altogether, an average Hjort maturity index of 4 was found in females with over 25% (17 out of 68) fully mature or spent (i.e., an index of either 6 or 7). Only one Hybrid \times dwarf female was completely immature (index of 1). Only the GSI of females with an index of less than 6 could be accurately measured for QTL analysis (i.e., those that had still retained their eggs inside the body cavity). For these females, the gonads consisted of 5.6% of the female Hybrid \times dwarf body weight (fig. 1f).

In the Hybrid \times Normal family, the observed sex ratio was 1:1 with 48 females and 48 males. In contrast to the Hybrid \times dwarf females, no females had fully matured to an index level of 6 (average index = 3.4), with only 3 females that were nearly mature with index levels of 5. For these females, the mean GSI was 10.4%, twice as high as that of the Hybrid \times dwarf family. However, given the large percentage of females that matured and were spent

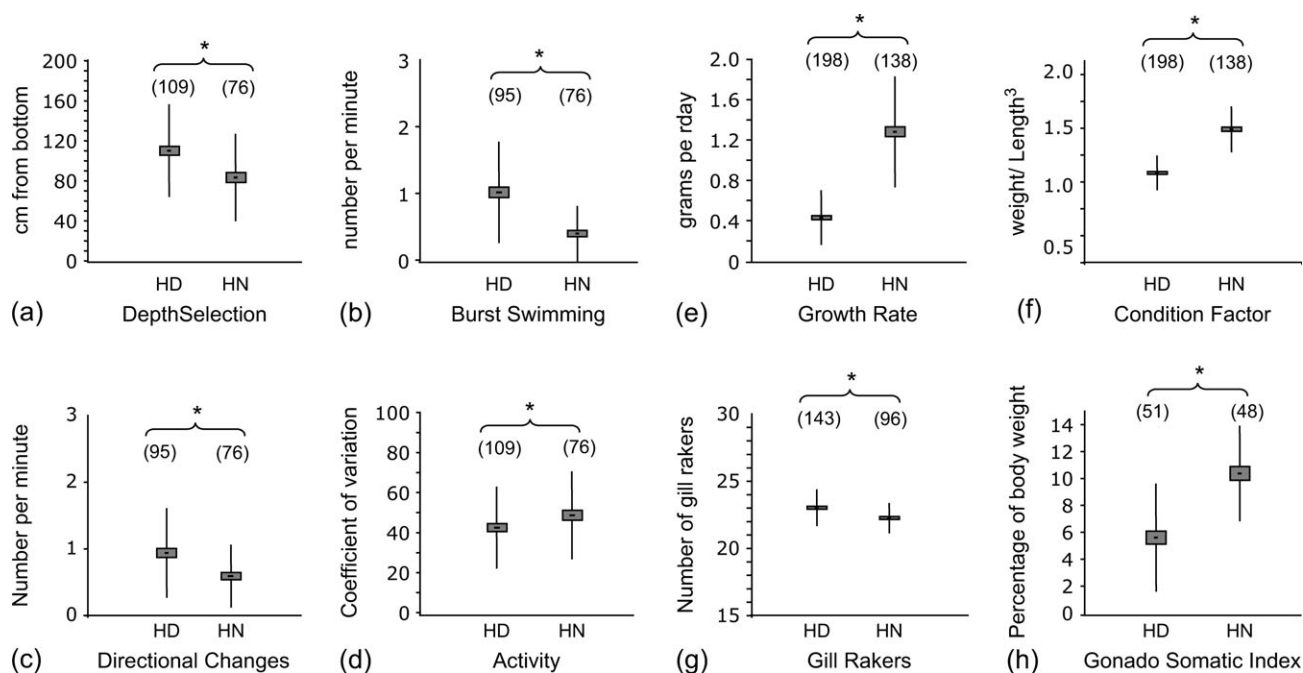

FIG. 1.—Phenotypic distributions for adaptive traits measured in each of the Hybrid \times dwarf and Hybrid \times Normal backcrosses. (Asterisk indicates significant difference, ANOVA, $P < 0.0001$. See Materials and Methods for details). The mean and standard error are represented by the dash and the box plots, respectively, whereas the lines indicate the standard deviation. The number of observations made in each backcross is given in parentheses.

(eggs expelled from body cavity) in the Hybrid \times dwarf family, compared with none that fully matured in the Hybrid \times Normal family, this prevented accurate phenotypic comparisons of GSI between families for this trait. Yet, these observations indicated a genetic basis for dwarf individuals maturing younger than normal individuals, consistent with observations in nature.

QTL Results

All results relevant to the construction and organization of the genetic maps are presented elsewhere (Rogers and Bernatchez 2007). At least one significant QTL was detected for all traits with the exception of the GSI. In the Hybrid \times dwarf family, between 1 and 7 QTL were detected for each of the 9 traits tested for a total of 24 QTL over all traits (table 1). In the Hybrid \times Normal family, between 1 and 5 QTL were detected for each of the 9 traits tested for a total of 10 QTL over all traits (table 2).

Behavioral QTL

We found evidence for 10 significant behavioral QTL, including 3 for each of the depth selection and burst swimming traits and 2 for each of the directional change and activity phenotypes (table 1). Each individual behavioral QTL explained between 12.2% (activity) and 25.8% (depth selection) of the total phenotypic variance (PVE) observed, consistent with segregating behavioral QTL of an intermediate to large effect. The cumulative PVE for these QTL explained 27.3% (activity) to 59.4% (depth selection) of the total experimental variance in the Hybrid \times dwarf fam-

ily (table 1). Behavioral QTL were distributed over 7 linkage groups (fig. 2). Five significant behavioral QTL were identified in the Hybrid \times Normal family; 2 for burst swimming and directional changes and one QTL for activity level (table 2). Behavioral QTL in this family individually explained between 16.3% (activity) and 31.5% (directional changes) of the total PVE observed per behavior. Cumulatively, these QTL explained 16.3% (activity) to 59.7% (directional changes) of the total experimental variance in the Hybrid \times Normal family. These QTL were distributed over 5 linkage groups. In certain instances, QTL regions in the Hybrid \times Normal family overlapped with those regions associated with QTL in the Hybrid \times dwarf family, such as ACTC086.6 (Lg32), which was significantly associated with burst swimming QTL in both hybrid backcrosses (fig. 2).

Growth QTL

Seven growth QTL were detected in the Hybrid \times dwarf family, individually explaining between 6.6% and 16.5% of the total PVE observed, that is, many QTL of an intermediate effect. Cumulatively, these QTL explained 69.2% of the total experimental variance in the Hybrid \times dwarf family and were distributed over 6 linkage groups (table 1 and fig. 2). Four growth QTL were detected in the Hybrid \times Normal family, individually explaining between 9.7% and 12.7% of the total PVE observed. Cumulatively, growth QTL in the Hybrid \times Normal family explained 46.6% of the total experimental variance observed and were distributed over 3 linkage groups (table 1). Three growth QTL segregated onto the same linkage groups in both families (Lg1, Lg8, and Lg11). Of these, marker

Table 1
QTL in the Hybrid × dwarf Backcross

Trait	N	Lg	Position (cM)	QTL interval		LOD	PVE (%)	1.5 LOD units of support (range in cM)
Behavioral								
Depth selection	109	15	101.6	ACTT150.3	ACTT175.7	6.27 ^a	25.4	88.3–121.0
Depth selection	109	24	12.01	CAAG179.7	CTAG102.8	3.23 ^b	18.1	0.01–22.5
Depth selection	109	32	6.01	ACTA121.6	ACTA114.6	3.27 ^b	15.5	8.1–18.3
Burst swimming	95	7	86.91	CATA143.2	CATA121.3	3.72 ^c	17.9	72.3–102.9
Burst swimming	95	32	163.11	ACTC086.5	ACTC102.1	3.72 ^c	14.4	149.1–185.7
Burst swimming	95	33	74.21	CCTG089.2	CCTG109.8	3.58 ^c	14.9	65.3–86.2
Directional change	95	14	89.01	CAAG116.1	CAAG126.8	3.85 ^c	17.7	77.0–89
Directional change	95	24	59.31	CAAG200.9	CAAG163.0	3.52 ^c	20.1	53.3–67.3
Activity	109	6	116.31	CTTC155.1	<i>CoCl₆</i>	3.15 ^b	14.5	110.3–121.0
Activity	109	14	163.61	CAAG160.5	CAAG120.6	3.00 ^b	12.8	161.5–167.6
Physiological								
Growth rate	198	1	141.01	GGTG105.0	GGTG107.9	4.38 ^a	10.5	119.1–160
Growth rate	198	4	157.11	CATA120.2	CATA108.8	4.37 ^a	11.6	142–161
Growth rate	198	7	96.91	CATA121.3	CATA122.0	3.24 ^c	7.8	78.3–120.5
Growth rate	198	8	42.41	CCTC122.9	CGTC061.8	3.65 ^c	8.8	0.1–42.4
Growth rate	198	8	12.01	ACTA102.7	CAAG054.5	6.01 ^a	16.5	0.1–24.5
Growth rate	198	11	17.4	CATA136.3	CATA087.1	3.03 ^b	7.4	9.4–22.6
Growth rate	198	24	89.01	CAAG176.8	CATA078.9	2.72 ^{b,d}	6.6	89.1
Morphological								
Condition factor	198	1	141.01	GGTG105.0	GGTG107.9	2.63 ^c	6.5	135.7–164.0
Condition factor	198	6	20.1	ACTA057.6	<i>Cocl₂₃</i>	3.22 ^c	7.8	6.1–33.0
Condition factor	198	32	17.1	ACTC114.6	ACTC073.5	2.73 ^c	7.7	9.7–47.2
Gill raker	143	24	148.71	ACTA076.0	GGTG120.0	3.85 ^a	13.1	135.6–158.7
Gill raker	143	25	36.61	CGTC291.1	CAAT138.3	3.19 ^c	11.5	30.6–49.6
Gill raker	143	36	64.11	CGTC072.3	GGTG081.3	3.17 ^c	13.4	41.3–72.1
Life history								
Onset of maturity	68	25	0.01	CCTC084.8	CCTG077.2	3.59 ^c	22.0	0.01–10.1

NOTE.—Interval-mapping analysis of 9 quantitative traits listed according to the category of trait: behavioral, physiological, morphological, and life history. *N* refers to the sample size and Lg refers to the linkage group within which the QTL was detected. QTL interval and position (cM) refer to the marker interval showing the most likely association to the phenotype with its position (cM) measured from the 1st marker and the corresponding 1.5 LOD units of support (but see also fig. 2). Microsatellite loci in QTL interval are italicized (see fig. 2). LOD refers to the log of odds significance level as determined by 1,000 permutations. The PVE represents the percentage of phenotypic variance explained by the QTL.

^a Experiment wise $\alpha < 0.01$.

^b Experiment wise $\alpha < 0.10$.

^c Experiment wise $\alpha < 0.05$.

^d QTL was at the $\alpha = 0.10$ significance limit, therefore, inferred as marginal evidence for growth QTL.

GGTG105.1 was homologous and significantly associated with growth on Lg1 in both the Hybrid × dwarf and Hybrid × Normal genetic backgrounds (fig. 2).

Morphological QTL

In the Hybrid × dwarf family, 3 QTL were associated with condition factor, each explaining between 6.5% and 7.8% of the PVE observed. Condition factor QTL had a cumulative PVE of 22% and were distributed over 3 linkage groups (table 1). There were no significant condition factor QTL detected in the Hybrid × Normal family, although a statistical trend for an association was observed for 1 interval on Lg32 (position 48.31 cM, ACTC175.4–ACTC138.4, LOD = 2.48) (table 2). Three QTL gill rakers were detected in only the Hybrid × dwarf family, each explaining between 11.5% and 13.4% and overall explaining 38% of the PVE (table 1) and distributed over 3 linkage groups (fig. 2).

Life History QTL

Onset of maturity and GSI could only be analyzed for female individuals, thus greatly reducing the sample size. In

the Hybrid × dwarf family, only one QTL was associated with the onset of maturity explaining 22% of the PVE on Lg25 (table 1). A single QTL for GSI was also detected on the same linkage group (LOD = 3.81, PVE = 43.7%), but presumably the low sample size ($N = 51$) due to some females that were fully mature/spent contributed to high LOD threshold values that precluded experiment-wise significance and contributed to the inflated PVE (table 1). In the Hybrid × Normal family, only one QTL was detected for onset of maturity (Lg15, PVE = 30.6%) (table 2).

Overlapping QTL of Different Traits

We also observed several instances of overlapping QTL across traits. In the Hybrid × dwarf family, 3 linkage groups (Lg1, Lg7, and Lg24) consisted of overlapping QTL or QTL in close proximity based on the range of the 1.5-LOD support units (table 1 and fig. 2). On Lg1, overlapping QTL were associated with growth (119–160 cM) and condition factor (135.7–164.0 cM). On Lg7, QTL associated with both growth (78.3–120.5) and burst swimming (72.3–102.9 cM) also overlapped (fig. 2). Lg24 was associated with a marginal QTL for growth (89.1 cM) which

Table 2
QTL in the Hybrid × Normal Backcross

Trait	N	Lg	Position (cM)	QTL interval		LOD	PVE	1.5 LOD units of support (range in cM)
Behavioral								
Burst swimming	76	6	173.31	ACTA184.9	AGTC092.5	3.06 ^a	16.8	170.0–195.8
Burst swimming	76	32	94.81	ACTC086.6	ACTC105.1	4.34 ^b	22.8	80.3–118.8
Directional changes	76	7	70.01	CTTC162.5	CTTC165.2	3.94 ^b	31.6	47.9–74.0
Directional changes	76	23	118.51	AGTT256.3	AGAC282.1	3.33 ^b	28.2	97.0–138.8
Activity	76	25	78.01	ACTA258.4	ACTA075.0	2.81 ^a	16.3	75.4–81.4
Physiological								
Growth	138	1	31.11	GGTG100.7	GGTG105.1	3.24 ^b	11.7	23.1–41.4
Growth	138	8	10.01	AGTC053.0	AGTC054.0	3.39 ^b	12.7	0.1–19.8
Growth	138	8	55.41	CAAG051.7	GGTG081.7	2.72 ^a	9.7	55.4–55.4
Growth	138	11	34.31	CATA101.9	CATA124.9	3.18 ^b	12.5	14.1–42.3
Life history								
Onset of maturity	48	15	0.01	AGTT169.7	ACTT269.7	2.85 ^a	30.6	0.1–14.1

NOTE.—Interval-mapping analysis of 9 quantitative traits listed according to the category of trait: behavioral, physiological, morphological, and life history. See table 1 for explanations.

^a Experiment wise $\alpha < 0.10$.

^b Experiment wise $\alpha < 0.05$.

was within 21 cM of a QTL for directional changes (53.3–67.3 cM) and proximal to a QTL for depth selection (0.01–22.5 cM) and gill rakers (135.6–158.7 cM) (fig. 2).

QTL and Segregation Distortion

Both AFLP and microsatellite loci exhibited deviations from Mendelian expectations in the genetic map, with 30.4% exhibiting significant segregation distortion across 28 linkage groups of the 4 linkage maps of both families (detailed in Rogers et al. 2007). The degree and direction of segregation distortion among mapped loci between families are correlated (Spearman $R = 0.378$, $P = 0.0021$), indicating that changes in different genomic regions have resulted in chromosomal regions that are no longer complementary between genomes (Rogers and Bernatchez 2006, 2007). To this end, we observed that 33% of QTL in the Hybrid × dwarf and 56% of QTL in the Hybrid × Normal backcross were associated with mapped regions exhibiting segregation distortion (fig. 2). There were certain distorted regions also associated with outliers under the influence of selection among natural populations (see below; CATA104.5 and CATA120.2 for growth QTL on Lg4; CCTC122.9 and CCTC061.8 for growth on Lg8; CATA101.9 for growth on Lg11; and CAAG069.8 and CAAG116.1 for directional change QTL on Lg14; fig. 2).

Map-Based Genome Scans among Natural Sympatric Pairs

Among 440 polymorphic loci previously characterized among 4 sympatric population pairs (Campbell and Bernatchez 2004), 180 loci were homologous and present within the 403 loci mapped in the Hybrid × dwarf family.

These 180 loci were distributed over 34 of 37 linkage groups. Fewer polymorphic loci among sympatric pairs were homologous with the Hybrid × Normal map, with 131 homologous loci among the 467 mapped in the Hybrid × Normal family. These were distributed over 27 of the 41 current linkage groups in this family. A total of 39 of these loci in both families included loci associated with QTL (33 in the Hybrid × dwarf and 8 in the Hybrid × Normal family, with 2 being shared between families; fig. 2).

Genome scans estimating the extent of genetic differentiation at single loci between sympatric dwarf and normal whitefish species pairs among 4 lakes identified 24 outliers with F_{ST} values higher than the 95% quantile for these map-based loci (see table 3 for the 95% quantile significance thresholds generated from simulations in each lake). These were therefore considered as candidates under the effect of directional selection (table 3). Overall, 19 of these outliers were found in Hybrid × dwarf family, whereas 8 outliers segregated in the Hybrid × Normal family (3 of these outliers were the same loci between families). Nine outliers were located on QTL in the Hybrid × dwarf family. Globally, a χ^2 indicated that the proportion (47%) of outlier QTL (9 QTL outliers out of 19 outliers) exhibiting a signature of selection among lakes was significantly higher than an expected proportion of 19% of map-based loci that should be associated with QTL by chance alone. This is based on the observation that 33 loci (within 1.5 LOD units of support) were associated with QTL among the 180 map-based loci that were used in this genome scan (19% of 19 outliers = 3.6 QTL outliers expected) ($\chi^2 = 8.15$, $P = 0.0015$). These 9 QTL outliers were distributed over 6 linkage groups (Lg1, Lg4, Lg6, Lg7, Lg8, and Lg14) associated with growth, burst swimming, activity, and directional changes. One of these outliers on Lg4, CATA104.5, was significantly

→

FIG. 2.—Distribution of significant QTL and the locations of significant outliers among natural sympatric pairs in sex-specific genetic linkage maps (denoted by female [♀] and male [♂]) for the dwarf, Normal, and Hybrid parents in the lake whitefish (see tables 2–4 for detailed corresponding QTL and genome scan information). Linkage groups are ordered vertically by family with the Hybrid × dwarf family on the left and the Hybrid × Normal family on the right. Downward arrows indicate underrepresented loci, whereas solid upward arrows indicate overrepresented loci exhibiting segregation distortion ($P < 0.00001$). Microsatellite loci are italicized to distinguish from AFLP loci.

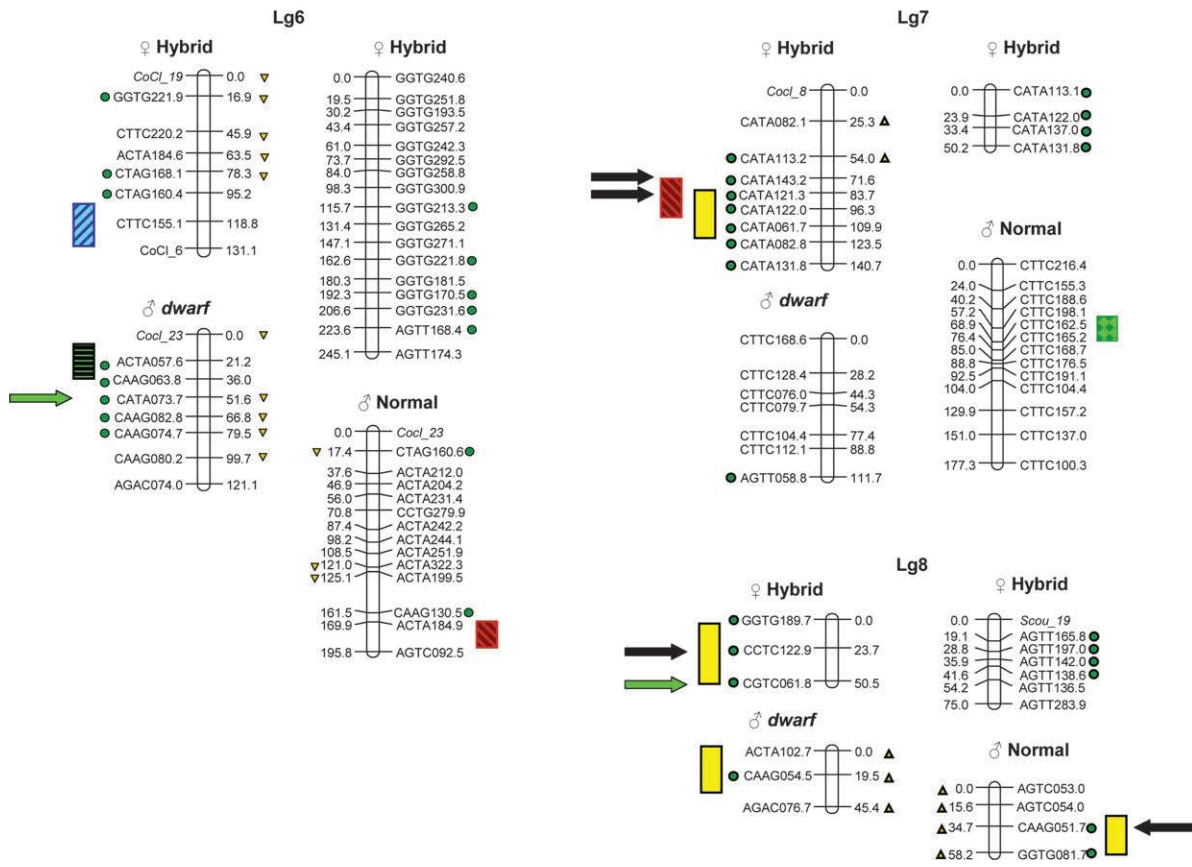
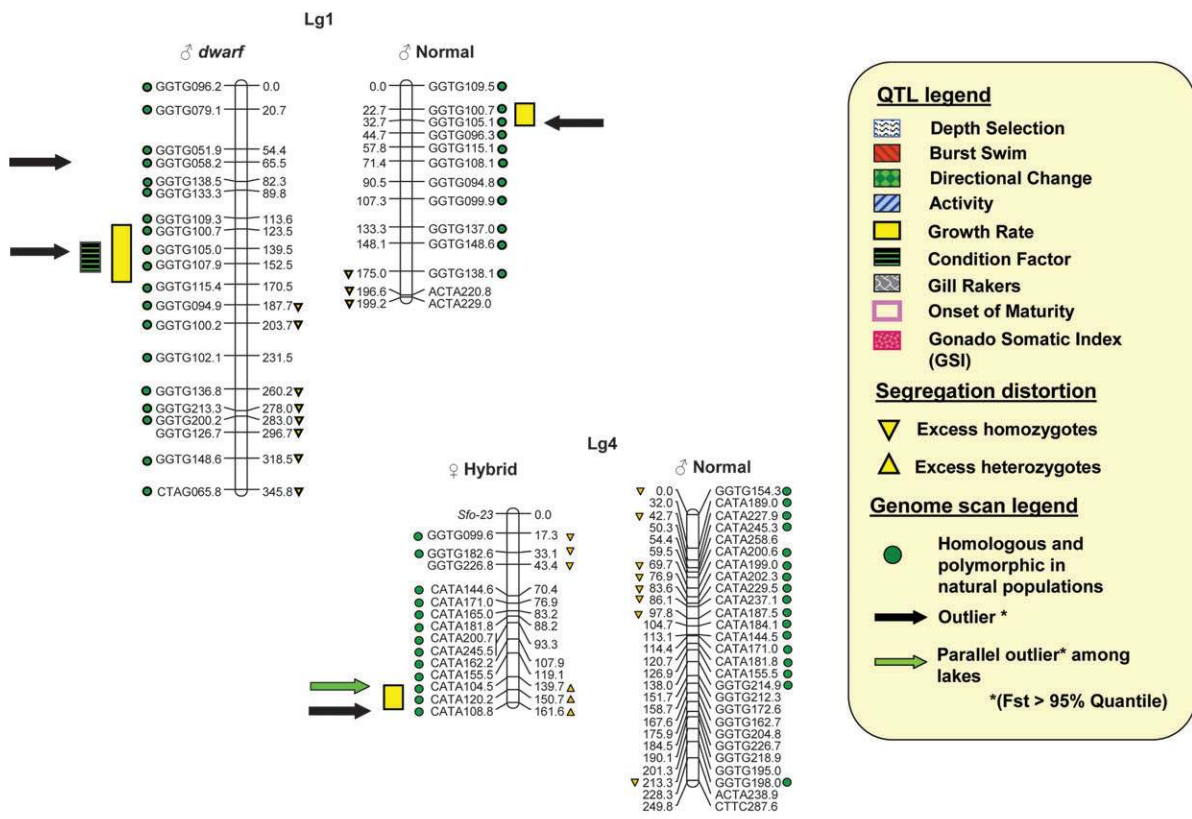

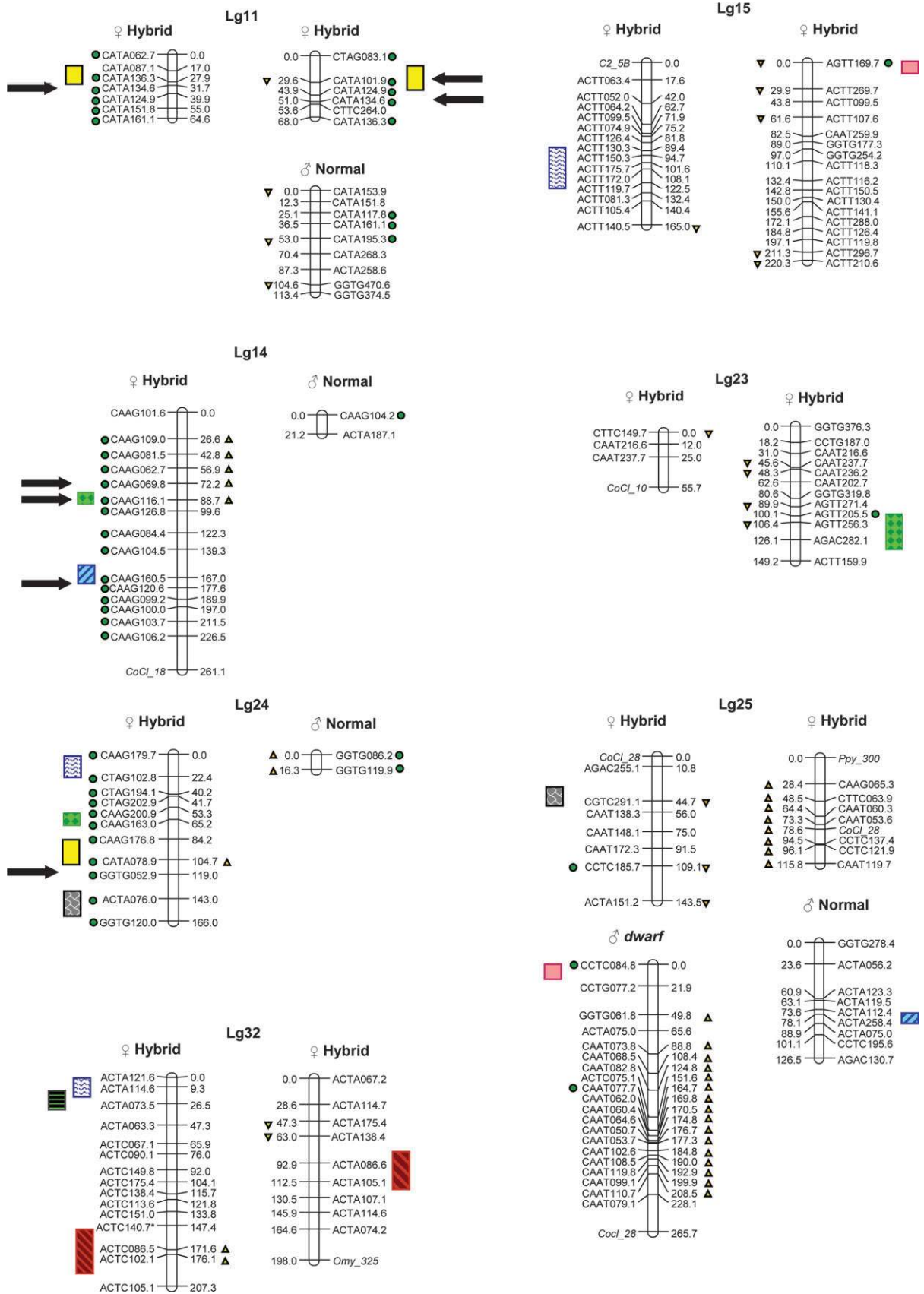

FIG. 2. (Continued)

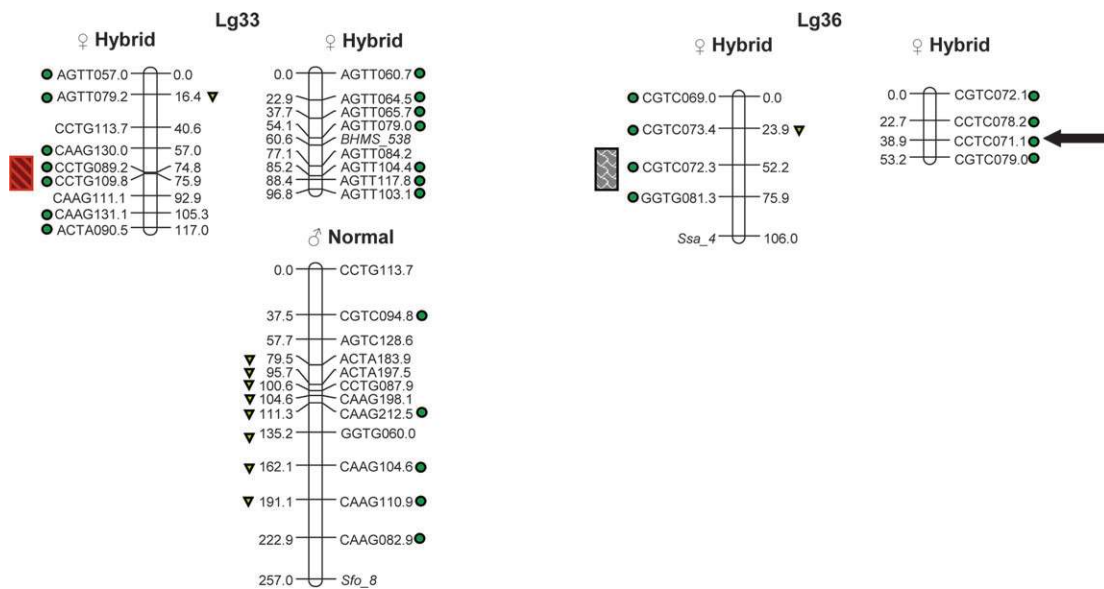

FIG. 2. (Continued)

associated with growth (LOD = 2.83, PVE = 7.3%, $P = 0.032$), but the most likely position for this QTL was downstream at 157.1 cM in the Hybrid \times dwarf family (tables 1 and 3). QTL on 3 linkage groups (Lg4, Lg6, and Lg8) exhibited parallel reductions of gene flow among more than one sympatric species pairs and were associated with growth (Lg4 and Lg8) and condition factor (Lg6) (table 3). Four additional outliers were located just outside of the 1.5 LOD units of support and may have therefore been indirectly under the influence of selection via hitchhiking (fig. 2 and table 3). These included CATA073.7, an outlier marginally associated with condition factor on Lg6; CATA0134.6, an outlier marginally associated with growth on Lg11; CAAG069.8, an outlier marginally associated with directional changes on Lg14; and GGTG052.9, an outlier marginally associated with gill rakers on Lg24.

In the Hybrid \times Normal family, 8 loci within the map showed a signature of selection and were distributed among 4 linkage groups (Lg1, Lg8, Lg11, and Lg36) associated only with growth (table 3). Four of these outliers (50%) were associated with QTL. Globally, a χ^2 test indicated that the proportion of outlier QTL was higher than an overall expected proportion of 6.1% of outliers expected by chance alone (based on 8 QTL segregating the 130 map-based loci for this family, thus $0.061\% \times 8$ outliers = 0.49 QTL outlier expected) ($\chi^2 = 12.93$, $P = 0.0002$). These QTL were all associated with growth and distributed over 3 linkage groups (Lg1, Lg8, and Lg11) (fig. 2). Notably, these linkage groups were also associated with growth in the Hybrid \times dwarf family.

Discussion

The objective of this study was to elucidate the genetic architecture of ecological speciation in diverging dwarf and normal lake whitefish species pairs. Our data from 2 hybrid backcross families provided strong evidence for the joint genetic basis of behavioral, physiological, morphological, and life history traits contributing to adaptive divergence between

dwarf and normal species pairs. Homologous loci among natural populations that exhibited significantly high levels of genetic divergence compared with neutral expectations were more often associated with these adaptive QTL relative to other regions of the genome than expected by chance. Altogether, QTL loci exhibiting significant reductions of gene flow were observed for swimming behavior, growth, condition factor, and marginally to the number of gill rakers. These results illustrate how divergent natural selection is currently maintaining differentiation between dwarf and normal species pairs of whitefish at many traits and provide strong empirical support for the ecological speciation hypothesis.

Genetic Architecture of Adaptation

One or more significant QTL were detected for all traits measured. At least 24 QTL detected within the Hybrid \times dwarf family and 10 within the Hybrid \times Normal family underlie the genetic basis of these divergent traits between dwarf and normal whitefish. Aside from QTL for growth (loci on Lg1, Lg8, and Lg11) and directional changes (loci on Lg32), most QTL in one genetic background were not observed in the other. In the Hybrid \times dwarf family, we are effectively looking at the segregation of the normal whitefish into a dwarf genetic background, whereas in the Hybrid \times Normal, it is the segregation of the dwarf allele in a primarily normal genetic background. Thus, the detection of QTL will primarily be determined by the presence of significant phenotypic differences in the parental lines used to generate the cross. However, differences in the magnitude of additive effects for QTL between the 2 backcrosses may also be due to dominance. For example, a case of complete dominance would lead to a significant effect in one backcross (e.g., Aa vs. aa) but no effect in the other (AA vs. Aa) (Vieira et al. 2000). Indeed, whereas there were more than twice the number of QTL detected in the Hybrid \times dwarf family (24 in Hybrid \times dwarf vs. 10 in the Hybrid \times Normal), the average magnitude of effect was higher

Table 3
Summary of Map-Based Loci Exhibiting Outlier Levels of Divergence in Homologous Loci among Natural Sympatric Pairs

Locus	Lg	QTL trait(s) associated with locus	F_{ST} level of differentiation between sympatric dwarf and normal pairs			
			East lake $Q_{95} = 0.256$	Webster lake $Q_{95} = 0.362$	Indian pond $Q_{95} = 0.196$	Cliff lake $Q_{95} = 0.456$
Hybrid \times dwarf						
GGTG058.2	1	—	<0.001	0.172	<0.001	0.780 ^a
GGTG105.0	1	Growth	<0.001	0.163	<0.001	0.865 ^a
CATA104.5	4	Growth ^b	0.449 ^c	0.369 ^c	0.032	0.617 ^c
CATA108.8	4	Growth	<0.001	0.248	0.199 ^a	<0.001
CATA073.7	6	Condition factor (<i>h</i>)	0.1454	0.3947 ^c	0.258 ^c	0.461 ^c
CATA143.2	7	Growth, burst swimming	<0.001	0.225	0.271 ^a	0.184
CATA121.3	7	Growth, burst swimming	0.094	0.201	0.258 ^a	<0.001
CCTC122.9	8	Growth	<0.001	0.005	0.043	0.595 ^a
CGTC061.8	8	Growth	0.045	0.0436	0.229 ^c	0.865 ^c
CGTC187.6	10	—	0.020	>0.999 ^a	<0.001	0.078
CATA134.6	11	Growth (<i>h</i>)	0.079	0.249	0.339 ^a	0.103
CAAG069.8	14	Directional changes (<i>h</i>)	0.293 ^a	0.2472	0.001	<0.001
CAAG116.1	14	Directional changes	0.309 ^a	0.3107	0.076	0.013
CAAG120.6	14	Activity level	0.252 ^a	0.2585	0.001	0.377
CCTC051.3	19	—	<0.001	<0.001	0.012	0.871 ^a
GGTG052.9	24	Gill rakers (<i>h</i>)	<0.001	0.0461	0.016	0.822 ^a
CATA158.6	27	—	<0.001	0.179	0.416 ^a	0.323
CGTC060.7	28	—	0.050	0.0436	0.229	0.865 ^a
CCTC116.9	30	—	0.140	0.427 ^a	0.020	0.010
Hybrid \times Normal						
GGTG105.1	1	Growth	<0.001	0.163	<0.001	0.865 ^a
CAAG51.7	8	Growth	0.061	0.047	<0.001	0.539 ^a
CATA134.6	11	Growth (<i>h</i>)	0.080	0.249	0.339 ^a	0.102
CATA101.9	11	Growth	0.011	<0.001	<0.001	0.501 ^a
CTAG061.0	12	—	<0.001	<0.001	0.045	0.749 ^a
GGTG139.9	22	—	<0.001	0.127	0.076	0.461 ^a
CGTC060.7	28	—	0.050	0.044	0.229	0.865 ^a
CCTC071.1	36	—	0.020	0.448 ^a	0.012	0.021

NOTE.—Several outliers associated to QTL and exhibiting significant outlier levels of genetic differentiation ($>Q_{95}$, as defined in Campbell and Bernatchez 2004) between sympatric pairs among 4 lakes as shown by the QTL trait column (— indicates no detected QTL associated with outlier). Loci in bold indicate homologous loci between families. Lg refers to linkage group in mapping family. See tables 1 and 2 for details regarding location, significance, magnitude, and direction of effect for all QTL. All outlier loci were either (i) significantly associated within 1.5 LOD units of support (see fig. 2 for the location of QTL and significant outliers on the linkage map) or (ii) traits marked with (*h*) were outside the support column for QTL and are only considered as possible candidates for hitchhiking.

^a Indicates F_{ST} outlier significantly greater than the 95% quantile of the expected value under neutrality.

^b Significantly associated with growth (LOD = 2.83, $P = 0.032$), peak location is 157.1 cM on Lg4 (see table 1 and fig. 1).

^c Indicates parallel observation of significant F_{ST} outlier values.

in the Hybrid \times Normal backcross (average Hybrid \times dwarf PVE = 13.4% vs. average Hybrid \times Normal PVE = 19.3%). This may be an indication that certain traits, such as depth selection and burst swimming behavior, may consist of a dominant genetic basis with the dominant alleles segregating in both genetic backgrounds. This would be consistent with observations of the quantitative genetic basis of these behaviors in the parental lines, where dominance was observed in the F1 hybrids (Rogers et al. 2002). In such cases, determining the parental source of the genotype will be complicated. This was likely complicated further by the fact that these backcrosses originated from outbred sources but overall suggest that both additive and dominant effects may be influencing adaptive divergence and consequently it will be important to investigate multiple genetic backgrounds when dissecting the genetic architecture of complex traits.

The magnitude of single QTL phenotypic effects averaged 16% across all traits and both families, but considerable variation was observed among traits. These results are consistent with genetic studies in plants (e.g., Bradshaw et al. 1995; Kim and Rieseberg 1999; Ungerer and Rieseberg 2003), insects (e.g., Jones 1998; Hawthorne and Via 2001),

and other vertebrates (Peichel et al. 2001; Albertson et al. 2003), indicating that evolutionary changes during population divergence are under the control of genes with a variable magnitude of effect, of which some QTL account for a substantial fraction of the variance observed in certain traits (Orr 2001; Coyne and Orr 2004; Orr 2005a).

QTL linked to adaptive traits are statistically associated with genes or other causal variants affecting trait differences (Goldstein and Weale 2001). The underlying nature of linkage disequilibrium between trait and such marker associations may be highly variable (Reich et al. 2001). Previous studies have shown that although the effects of selection are locus-specific, linkage disequilibrium may implicate other loci over larger physical distances if selection for the trait in question is strong enough (Goldstein and Weale 2001; Reich et al. 2001). Similarly, it is plausible that QTL associated with gill rakers on Lg24 could appear to be under the effect of selection in Cliff Lake only because of hitchhiking with the closely linked GGTG052.9, an outlier proximate to 3 adaptive traits, 2 of which overlap (fig. 2). Admittedly, this remains hypothetical until we can determine to what extent selection implicates linkage disequilibrium among these loci in natural populations, which will be

important toward understanding the impact of selection on the current genetic architecture (Charlesworth et al. 1997). For example, if specific genomic regions influence more than one adaptive trait, these genomic regions are also more likely to be involved in reproductive isolation, whereby intermediate genotypes will affect several intermediate hybrid phenotypes, thus increasing the chances of prezygotic and postzygotic reproductive isolation (Rice and Hostert 1993; Hawthorne and Via 2001).

Many QTL loci did not exhibit a signature of selection among natural populations of whitefish, and many of the outliers were not under the influence of selection in more than one environment. Confounding demographic, spatial, or local effects on adaptive divergence may affect F_{ST} among environments (Beaumont and Balding 2004; Storz 2005).

Consequently, disentangling the effects of demography and reducing the chances of false positives will continue to require the integration of multiple approaches to detecting selection, both at the level of natural populations (Bonin et al. 2006) and with respect to making links back to the underlying candidate genomic regions (Stinchcombe and Hoekstra 2007).

Variation in genetic architecture or genotype \times environment interactions may also preclude the detection of adaptive traits under selection (Hoekstra and Nachman 2003; Gardner and Latta 2006). For example, the polygenic nature of adaptive traits may result from the role of selection acting on all QTL simultaneously giving the appearance of neutrality when considering each locus individually (McKay and Latta 2002). This is coupled with the observation that allelic covariance among QTL could result in substantial adaptive phenotypic change despite relatively small phenotypic effects of each individual locus (Le Corre and Kremer 2003). QTL detection will be dependent on alleles with significantly different trait effects segregating in the mapping family. Therefore, theory predicts that differential effects are expected between genetic backgrounds even in the absence of selection (Tanksley and Hewitt 1988; Leips and Mackay 2000; Ungerer et al. 2003). This is important to consider in the context of adaptive divergence when given that allelic fitness may likely depend on its genetic background (Ungerer and Rieseberg 2003). Nonetheless, evidence from both divergent genetic backgrounds suggests that at least 3 linkage groups exhibited QTL loci associated with growth that were significantly divergent between natural sympatric species pairs, offering particularly strong evidence of a functional genomic response to selection for differential growth.

Relationship between Adaptive Divergence and Reproductive Isolation

Dobzhansky (1951) proposed that the genotype of a species is an integrated system adapted to the environment or ecological niche in which the species lives, whereby recombination in the offspring of hybrids may lead to the formation of discordant gene patterns. The final “component” of ecological speciation involves the genetic mechanism by which selection of ecological traits is transmitted to the genes causing reproductive isolation (Schluter 2000; Rundle and Nosil 2005). The detection of QTL and evidence of

the role of selection at these QTL offer tangible evidence for elucidating the genetic basis of reproductive isolation in the adaptive divergence of dwarf and normal species pairs. The questions that now arise pertain to how and why these adaptive QTL experience a significant reduction in gene flow compared with the rest of the genome. This includes distinguishing between the genes under divergent selection and those actually causing reproductive isolation (Wu and Hollocher 1998; Wu and Ting 2004). Notably, 33% of QTL in the Hybrid \times dwarf and 56% of QTL in the Hybrid \times Normal backcross were associated with segregation distortion. These distorted regions were also associated with outliers under the influence of selection among natural populations (e.g., outliers for growth QTL on Lg4, Lg8, Lg11 and for directional change QTL on Lg14; fig. 2). Segregation distortion due to hybrid inviability may be considered as locus-specific evidence of selection for or against genotypes (Rieseberg et al. 1993; Launey and Hedgecock 2001). Distorted loci may therefore be very important to acknowledge when studying the genetic basis of adaptation (Rieseberg et al. 1993; Orr 2005b). Although our sample sizes were low for QTL detection, they were high enough to ensure that contiguously distorted alleles were adequately represented in the sample size of the QTL interval analysis (Bradshaw et al. 1998). Ultimately, consideration of the relationship between the genetic basis of adaptive traits and hybrid inviability leading to segregation distortion will contribute to a more direct understanding of the consequences of adaptive divergence leading to the formation of reproductive isolation (Bradshaw et al. 1998). This will be particularly important for distorted loci associated to adaptive QTL that also exhibit significantly high levels of genetic divergence among parallel populations, such as those observed for adaptive QTL outliers associated with growth and condition factor on Lg4 and Lg6. Differential hybrid survival as a consequence of adaptive divergence for growth at these genomic regions appears likely and will need to be confirmed experimentally.

Ecological Speciation of Dwarf and Normal Lake Whitefish Species Pairs

Fishes in postglacial lakes have long been considered natural laboratories to study adaptive genetic variation (McPhail and Lindsey 1970; Robinson and Schluter 2000). Many northern temperate lakes inhabit sympatric dwarf and normal lake whitefish species pairs that have evolved independently (Pigeon et al. 1997). The level of genetic divergence between these sympatric pairs is directly related to the level of morphological specialization with respect to trophic niches, consistent with studies in other postglacial sympatric pairs that have cumulatively been considered strong support for the ecological speciation hypothesis (e.g., Coyne and Orr 2004; Rundle and Nosil 2005). However, ecological speciation must demonstrate that divergent natural selection is the principal cause of differentiation between dwarf and normal species pairs in the traits that are used to exploit these environments.

Here, evidence for directional selection acting on the genetic architecture of swimming behavior, growth, gill rakers, and life history also presents a hypothetical predictable

framework of events for the parallel evolution of distinct life histories that characterize dwarf and normal whitefish. Behavior is hypothesized to be the first trait to respond to selection in divergence toward limnetic habitats concordant with the consensus that expansion to new resources and environments remains the dominant ecological theme in adaptive radiation (Mayr 1963; Schluter 2000). Namely, habitat isolation and resource selection play a major role in the shift into new adaptive zones and initiating new evolutionary events. Within this context, the expansion to new resources follows a specific sequence of events involving an initial habitat separation followed by a divergence with respect to prey size and food types (Schluter 2000). *Dwarf* whitefish primarily feed on limnetic prey and exhibit genetically based habitat isolation by occupying higher positions in a water column (Bernatchez 2004). In the experimental families, the magnitude of effect for depth selection QTL was relatively high (PVE = 26%) compared with all other traits except directional changes, suggesting that this trait may have had the potential to respond quickly to selection upon colonization of the limnetic niche.

Subsequent divergence during the exploitation of novel limnetic resources may have contributed to selection on additional behavioral traits. For example, predation carries the ultimate fitness cost (Vamosi and Schluter 2002), and limnetic dwarf whitefish are more likely to be preyed upon by large salmonids (e.g., lake trout) when compared with their benthic counterparts (Kahilainen and Lehtonen 2003). The detected effect of divergent selection on behavioral QTL, such as an increase in directional turns and burst swims in dwarf fish, suggests that these traits may indeed increase predator avoidance (Domenici and Blake 1997; Rogers et al. 2002; Vamosi and Schluter 2002; Walker et al. 2005).

Additionally, behavioral strategies within limnetic environments may be correlated with growth (Walker et al. 2005). For example, significant biases in directional changes carry a higher energetic cost than normal swimming and affect ratios of white to red muscle in fishes (Heuts 1999). The burst swim response is energetically demanding and invokes a rapid wave of muscle contraction along one side of the vertebral axis which bends the fish into a C-shape (Weihs and Webb 1984). Burst swimming in fishes leads to peak accelerations that can occur within 0.02 s and has been measured as high as 40 body lengths per second (Domenici and Blake 1997). Because energetically demanding burst swimming is a fundamental locomotor behavior directly related to predator avoidance (and thus survival), this suggests a potential trade-off between predator escape and other traits (Walker et al. 2005). In lake whitefish, for instance, such predator avoidance behaviors may limit available energy that can be invested in growth and reproduction (Rogers et al. 2002). Under natural conditions, dwarf whitefish consume 40–50% more food than normal ecotypes, yet their conversion efficiency of these resources is less than half than that of the normal ecotype (Trudel et al. 2001). We propose that behavioral adaptation for occupying a limnetic environment may incur a substantial trade-off in energetic allocation between survival and growth for dwarf whitefish, which may partially explain why swimming behavior and growth are both targets of divergent selection.

It has been well established that dwarf whitefish, which have higher gill raker numbers, are associated with a diet of smaller, limnetic zooplanktonic prey, whereas normal ecotypes with fewer gill rakers fed mainly on larger, epibenthic preys (Bernatchez 2004). However, evidence of selection acting on loci in proximity to QTL associated with gill rakers (Lg24) was limited and observed only in Cliff Lake. Interestingly, Lg24 also comprises QTL associated with growth and behavioral traits for which evidence for selection was more pronounced. This raises the hypothesis that gill raker QTL could be indirectly selected by genetic correlation to these other traits in lake whitefish, although the distance between these different QTL is large.

Altogether, these data offer genomic evidence that divergent natural selection is maintaining genetic differentiation at several adaptive differences between dwarf and normal lake whitefish. They also suggest that adaptive divergence in the limnetic niche may ultimately favor dwarf whitefish that are smaller and mature earlier due to energetic constraints imposed by an increased swimming activity for planktonic feeding and predator evasion. The magnitude of phenotypic effects observed at the QTL controlling these traits supports the hypothesis that the evolution of adaptive divergence may have been rapid. This implies that overall there may have also been stronger selection on the dwarf ecotype compared with the normal with respect to this resource-based divergence. This is indirectly supported by the number of outlier loci we observed in the Hybrid \times dwarf backcross ($n = 19$ over 180 mapped loci) compared with the Hybrid \times Normal ($n = 8$ over 131 mapped loci). Although this would need to be confirmed with additional crosses under a controlled experimental design, it does offer a preliminary indication of stronger selection on the dwarf relative to the normal genetic background.

However, these phenotype–environment associations only partially predicted the genotype–environment associations, with many QTL outliers exhibiting variable levels of genetic divergence among independent environments. Consequently, the complex role of natural selection in generating/maintaining phenotypic diversity will only be understood by deciphering the mechanisms underlying both gene–gene and gene–environment interactions (Gardner and Latta 2006). To conclude, this study shows that a top-down framework, first seeking to identify phenotype–environment associations and subsequently to deciphering the genetic architecture and the role of selection, holds promise for investigations into the process of ecological speciation, particularly in nonmodel organisms.

Acknowledgments

We would like to thank LARSA for their support during the rearing of the whitefish, particularly Serge Higgins for helping with the design and construction of the behavioral tanks. We would also like to thank David Campbell, Lucie Papillon, Jerome Saint-Cyr for their help in various capacities, including surgically implanting the PIT tags and dissecting the fish. We are grateful to Guillaume Côté for his help with the growth experiments and the dissections.

We are grateful to N. Derome, D. Fraser, H. Gudereley, N. Isabel, E.B. Taylor, and A. Whiteley for discussions and comments that greatly improved this manuscript. We owe a tremendous debt of gratitude to David Basley of Maine Fish and Wildlife who has, over the past 2 decades, sacrificed countless hours of his personal time toward assisting with the sampling of whitefish. His expertise and knowledge of his lakes have contributed a great deal to the ongoing working hypotheses of lake whitefish evolution. L. Bernatchez's research program on the evolution and conservation of fishes is supported by grants from the Natural Sciences and Engineering Research Council of Canada, as well as by the Canadian Research Chair in Genomics and Conservation of Aquatic Resources. This paper is a contribution to the research program of Québec Océan.

Literature Cited

- Albertson RC, Streebman JT, Kocher TD. 2003. Directional selection has shaped the oral jaws of Lake Malawi cichlid fishes. *Proc Natl Acad Sci USA*. 100:5252–5257.
- Barbash DA, Awadalla P, Tarone AM. 2004. Functional divergence caused by ancient positive selection of a *Drosophila* hybrid incompatibility locus. *PLoS Biol*. 2:839–848.
- Basten CJ, Weir BS, Zeng Z-B. 2002. QTL cartographer. Raleigh (NC): Program in Statistical Genetics, Bioinformatics Research Center, Department of Statistics, North Carolina State University.
- Beaumont MA, Balding DJ. 2004. Identifying adaptive genetic divergence among populations from genome scans. *Mol Ecol*. 13:969–980.
- Bernatchez L. 2004. Ecological theory of adaptive radiation: an empirical assessment from Corigonine fishes (Salmoniformes). In: Hendry AP, Stearns S, editors. *Evolution illuminated: salmon and their relatives*. Oxford: Oxford University Press. p. 176–207.
- Bernatchez L, Dodson JJ. 1990. Allopatric origin of sympatric populations of Lake whitefish (*Coregonus clupeaformis*) as revealed by mitochondrial-DNA restriction analysis. *Evolution*. 44:1263–1271.
- Bonin A, Taberlet P, Miaud C, Pompanon F. 2006. Explorative genome scan to detect candidate loci for adaptation along a gradient of altitude in the common frog (*Rana temporaria*). *Mol Biol Evol*. 23:773–783.
- Boyartchuk VL, Broman KW, Mosher RE, D'Orazio SEF, Stambach MN, Dietrich W. 2001. Multigenic control of *Listeria monocytogenes* susceptibility in mice. *Nat Genet*. 27:259–260.
- Bradshaw HD, Otto KG, Frewen BE, McKay JK, Schemske DW. 1998. Quantitative trait loci affecting differences in floral morphology between two species of monkeyflower (*Mimulus*). *Genetics*. 149:367–382.
- Bradshaw HD, Wilbert SM, Otto KG, Schemske DW. 1995. Genetic-mapping of floral traits associated with reproductive isolation in monkeyflowers (*Mimulus*). *Nature*. 376:762–765.
- Campbell D, Bernatchez L. 2004. Genomic scan using AFLP markers as a means to assess the role of directional selection in the divergence of sympatric whitefish ecotypes. *Mol Biol Evol*. 21:945–956.
- Charlesworth B, Nordborg M, Charlesworth D. 1997. The effects of local selection, balanced polymorphism and background selection on equilibrium patterns of genetic diversity in subdivided populations. *Genet Res*. 70:155–174.
- Coyne JA, Orr HA. 2004. *Speciation*. Sunderland (MA): Sinauer Associates, Inc.
- Derome N, Duchesne P, Bernatchez L. 2006. Parallelism in gene transcription among sympatric lake whitefish (*Coregonus clupeaformis* Mitchell) ecotypes. *Mol Ecol*. 15:2370–2378.
- Dobzhansky T. 1951. *Genetics and the Origin of Species*. New York: Columbia University Press.
- Doerge RW, Churchill GA. 1996. Permutation tests for multiple loci affecting a quantitative character. *Genetics*. 142:285–294.
- Domenici P, Blake RW. 1997. The kinematics and performance of fish fast-start swimming. *J Exp Biol*. 200:1165–1178.
- Feder ME, Mitchell-Olds T. 2003. Evolutionary and ecological functional genomics. *Nat Rev Genet*. 4:651–657.
- Gardner KM, Latta RG. 2006. Identifying loci under selection across contrasting environments in *Avena barbata* using quantitative trait locus mapping. *Mol Ecol*. 15:1321–1333.
- Gharbi K, Gautier A, Danzmann RG, Gharbi S, Sakamoto T, et al. 2006. A linkage map for brown trout (*Salmo trutta*): chromosome homeologies and comparative genome organization with other salmonid fish. *Genetics*. 172:2405–2419.
- Goldstein DB, Weale ME. 2001. Population genomics: linkage disequilibrium holds the key. *Curr Biol*. 11:R576–R579.
- Hawthorne D, Via S. 2001. Genetic linkage of ecological specialization and reproductive isolation in pea aphids. *Nature*. 412:904–907.
- Heuts B. 1999. Lateralization of trunk muscle volume, and lateralization of swimming turns of fish responding to external stimuli. *Behav Processes*. 47:113–124.
- Hjort J. 1914. Fluctuations in the great fisheries of northern Europe. *Rapp P-V Reun Cons Int Explor Mer*. 20:1–227.
- Hoekstra HE, Nachman MW. 2003. Different genes underlie adaptive melanism in different populations of rock pocket mice. *Mol Ecol*. 12:1185–1194.
- Iwama GK. 1996. Growth of salmonids. In: Pennell W, Barton BA, editors. *Developments in aquaculture and fisheries science. Principles of salmonid culture*. Amsterdam (The Netherlands): Elsevier. p. 467–515.
- Jones CD. 1998. The genetic basis of *Drosophila sechellia*'s resistance to a host plant toxin. *Genetics*. 149:1899–1908.
- Kahilainen K, Lehtonen H. 2003. Piscivory and prey selection of four predator species in a whitefish dominated subarctic lake. *J Fish Biol*. 63:659–672.
- Kim SC, Rieseberg LH. 1999. Genetic architecture of species differences in annual sunflowers: implications for adaptive trait introgression. *Genetics*. 153:965–977.
- Lander ES, Green P, Abrahamson J, Barlow A, Daley M, Lincoln S, Newburg L. 1987. MAPMAKER, an interactive computer package for constructing primary genetic linkage maps of experimental and natural populations. *Genomics*. 1:174–181.
- Launey S, Hedgecock D. 2001. High genetic load in the Pacific oyster *Crassostrea gigas*. *Genetics*. 159:255–265.
- Le Corre V, Kremer A. 2003. Genetic variability at neutral markers, quantitative trait loci and trait in a subdivided population under selection. *Genetics*. 164:1205–1219.
- Leips J, Mackay TFC. 2000. Quantitative trait loci for life span in *Drosophila melanogaster*: interactions with genetic background and larval density. *Genetics*. 155:1773–1788.
- Lu G, Bernatchez L. 1998. Experimental evidence for reduced hybrid viability between dwarf and normal ecotypes of lake whitefish (*Coregonus clupeaformis* Mitchell). *Proc R Soc Lond B Biol Sci*. 265:1025–1030.
- Luikart G, England PR, Tallman D, Jordan S, Taberlet P. 2003. The power and promise of population genomics: from genotyping to genome typing. *Nat Rev Genet*. 4:981–993.
- Mayr E. 1963. *Animal species and evolution*. Cambridge (MA): Harvard University Press.
- McKay JK, Latta RG. 2002. Adaptive population divergence: markers, QTL and traits. *Trends Ecol Evol*. 17:285–291.

- McPhail JD, Lindsey CC. 1970. Freshwater fishes of northwestern Canada and Alaska. *Fish. Res. Bd. Can. Bull.* 173: 69–119.
- Nei M. 1977. F-statistics and analysis of gene diversity in subdivided populations. *Ann Hum Genet.* 41:225–233.
- Nei M, Chesser RK. 1983. Estimation of fixation indices and gene diversities. *Ann Hum Genet.* 47:253–259.
- Orr HA. 1998. Testing natural selection versus genetic drift in phenotypic evolution using quantitative trait locus data. *Genetics.* 149:2099–2104.
- Orr HA. 2001. The genetics of species differences. *Trends Ecol Evol.* 16:343–350.
- Orr HA. 2005a. The genetic theory of adaptation: a brief history. *Nat Rev Genet.* 6:119–127.
- Orr HA. 2005b. The genetic basis of reproductive isolation: insights from *Drosophila*. *Proc Natl Acad Sci USA.* 102:6522–6526.
- Orr HA, Coyne JA. 1992. The genetics of adaptation—a reassessment. *Am Nat.* 140:725–742.
- Orr M, Smith T. 1998. Ecology and speciation. *Trends Ecol Evol.* 13:502–506.
- Peichel CL, Nereng KS, Ohgi KA, Cole BLE, Colosimo PF, Buerkle CA, Schluter D, Kingsley DM. 2001. The genetic architecture of divergence between threespine stickleback species. *Nature.* 414:901–905.
- Pigeon D, Chouinard A, Bernatchez L. 1997. Multiple modes of speciation involved in the parallel evolution of sympatric morphotypes of lake whitefish (*Coregonus clupeaformis*, Salmonidae). *Evolution.* 51:196–205.
- Powers DA, Lauerman T, Crawford D, DiMichele L. 1991. Genetic mechanisms for adapting to a changing environment. *Annu Rev Genet.* 25:629–659.
- Presgraves DC, Balagopalan L, Abmayr SM, Orr HA. 2003. Adaptive evolution drives divergence of a hybrid inviability gene between two species of *Drosophila*. *Nature.* 423:715–719.
- Reeve HK, Sherman PW. 1993. Adaptation and the goals of evolutionary research. *Q Rev Biol.* 68:1–32.
- Reich D, Cargill M, Bolk S, et al. (11 co-authors). 2001. Linkage disequilibrium in the human genome. *Nature.* 411:199–204.
- Rice WR, Hostert EE. 1993. Laboratory experiments on speciation: what have we learned in 40 years? *Evolution.* 47:1637–1653.
- Rieseberg LH, Choi H, Chan R, Spore C. 1993. Genomic map of a diploid hybrid species. *Heredity.* 70:285–293.
- Rieseberg LH, Widmer A, Arntz AM, Burke J. 2002. Directional selection is the primary cause of phenotypic diversification. *Proc Natl Acad Sci USA.* 99:12242–12245.
- Robinson BW, Schluter D. 2000. Natural selection and the evolution of adaptive genetic variation in northern freshwater fishes. In: Mousseau T, Sinervo B, Endler JA, editors. *Adaptive genetic variation in the wild*. Oxford: Oxford University Press. p. 65–94.
- Rogers S, Gagnon V, Bernatchez L. 2002. Genetically based phenotype-environment association for swimming behavior in lake whitefish ecotypes (*Coregonus clupeaformis* Mitchell). *Evolution.* 56:2322–2329.
- Rogers SM, Bernatchez L. 2005. Integrating QTL mapping and genome scans towards the characterization of candidate loci under parallel selection in the lake whitefish (*Coregonus clupeaformis*). *Mol Ecol.* 14:351–361.
- Rogers SM, Bernatchez L. 2006. The genetic basis of intrinsic and extrinsic postzygotic reproductive isolation jointly promoting speciation in the lake whitefish species complex (*Coregonus clupeaformis*). *J Evol Biol.* 19:1979–1994.
- Rogers SM, Isabel N, Bernatchez L. 2007. Linkage maps of the dwarf and normal lake whitefish (*Coregonus clupeaformis*) species and their hybrids reveal the genetic architecture of population divergence. *Genetics.* 175:375–398.
- Rogers SM, Campbell D, Baird SJE, Danzmann RG, Bernatchez L. 2001. Combining the analyses of introgressive hybridisation and linkage mapping to investigate the genetic architecture of population divergence in the lake whitefish (*Coregonus clupeaformis*, Mitchell). *Genetica.* 111:25–41.
- Rundle HD, Nosil P. 2005. Ecological speciation. *Ecol Lett.* 8:336–352.
- Sakamoto T, Danzmann R, Gharbi K, Howard P, Ozaki A, et al. 2000. A microsatellite linkage map of rainbow trout (*Oncorhynchus mykiss*) characterized by large sex-specific differences in recombination rates. *Genetics.* 155:1331–1345.
- Sawamura K, Davis A, Wu C. 2000. Genetic analysis of speciation by means of introgression into *Drosophila melanogaster*. *Proc Natl Acad Sci USA.* 97:2652–2655.
- Schemske DW, Bradshaw HD. 1999. Pollinator preference and the evolution of floral traits in monkeyflowers (*Mimulus*). *Proc Natl Acad Sci USA.* 96:11910–11915.
- Schluter D. 2000. *The ecology of adaptive radiation*. New York: Oxford University Press.
- Schluter D, Nagel LM. 1995. Parallel speciation by natural selection. *Am Nat.* 146:292–301.
- Scotti-Saintagne C, Mariette S, Porth I, Goicoechea PG, Barreneche T, Bodenès K, Burg K, Kremer A. 2004. Genome scanning for interspecific differentiation between two closely related oak species [*Quercus robur* L. and *Q. petraea* (Matt.) Liebl.]. *Genetics.* 168:1615–1626.
- Stinchcombe JR, Hoekstra HE. Forthcoming 2007. Combining population genomics and quantitative genetics: finding the genes underlying ecologically important traits. *Heredity*. doi:10.1038/sj.hdy.6800937.
- Storz JF. 2005. Using genome scans of DNA polymorphism to infer adaptive population divergence. *Mol Ecol.* 14:671–688.
- Tanksley SD, Hewitt J. 1988. Use of molecular markers in breeding for soluble solids content in tomato—a re-examination. *Theor Appl Genet.* 75:811–823.
- Trudel M, Tremblay A, Schetagne R, Rasmussen J. 2001. Why are dwarf fish so small? An energetic analysis of polymorphism in lake whitefish (*Coregonus clupeaformis*). *Can J Fish Aquat Sci.* 58:394–405.
- Ungerer MC, Linder CR, Rieseberg LH. 2003. Effects of genetic background on response to selection in experimental populations of *Arabidopsis thaliana*. *Genetics.* 163:277–286.
- Ungerer MC, Rieseberg LH. 2003. Genetic architecture of a selection response in *Arabidopsis thaliana*. *Evolution.* 57:2531–2539.
- Vamosi SM, Schluter D. 2002. Impacts of trout predation on fitness of sympatric sticklebacks and their hybrids. *Proc R Soc Lond B Biol Sci.* 269:923–930.
- Vieira C, Pasyukova EG, Zeng ZB, Hackett JB, Lyman RF, Mackay TFC. 2000. Genotype-environment interaction for quantitative trait loci affecting life span in *Drosophila melanogaster*. *Genetics.* 154:213–227.
- Walker JA, Ghalambor CK, Griset OL, McKenney D, Reznick DN. 2005. Do faster starts increase the probability of evading predators? *Funct Ecol.* 19:808–815.
- Wallace B. 1953. On co-adaptation in *Drosophila*. *Am Nat.* 87:343–358.
- Weihls D, Webb PW. 1984. Optimal avoidance and evasion tactics in predator-prey interactions. *J Theor Biol.* 106:189–206.
- Wu CI, Hollocher H. 1998. Subtle is nature: the genetic of species differentiation and speciation. In: Howard DJ, Berlocher SH, editors. *Endless forms: species and speciation*. New York: Oxford University Press. p. 339–352.
- Wu CI, Ting CT. 2004. Genes and speciation. *Nat Rev Genet.* 5:114–122.

John H. McDonald, Associate Editor

Accepted March 19, 2007