

THE HEKATE METHODOLOGY. HYBRID ENGINEERING OF INTELLIGENT SYSTEMS

GRZEGORZ J. NALEPA, ANTONI LIGEŻA

Institute of Automatics, AGH University of Science and Technology, Al. Mickiewicza 30, 30-059, Kraków, Poland

This paper describes a new approach, the HeKatE methodology, for design and development of complex rule-based systems for control and decision support. The main paradigm for rule representation, namely the eXtended Tabular Trees (XTT), ensures high density and transparency of visual knowledge representation. Contrary to traditional, flat rule-based systems, the XTT approach is focused on groups of similar rules rather than single rules. Such groups form decision tables which are connected into a network for inference. Efficient inference is assured thanks to firing only rules necessary for achieving the goal, identified by context of inference and partial order among tables. In the paper the new version of the language – XTT² – is presented. It is based on the ALSV(FD) logic, also described in the paper. Another distinctive feature of the presented approach is a top-down design methodology based on successive refinement of the project. It starts with Attribute Relationship Diagram (ARD) development. Such a diagram represents relationships among system variables. Based on the ARD scheme, XTT tables and links between them are generated. The tables are filled with expert-provided constraints on values of the attributes. The code for rules representation is generated in a human-readable representation called HMR, and interpreted with provided inference engine called HeaRT. A set of software tools supporting the visual design and development stages is described in brief.

Keywords: rule-based expert systems, intelligent control, system design

1. Introduction

Rule-based systems constitute one of the most powerful and most popular knowledge representation formalisms (Liebowitz, 1998; van Harmelen, Lifschitz and Porter, 2007). They offer a relatively easy way of knowledge encoding and interpretation. Formalization of knowledge within a rule-based system can be based on mathematical logic (e.g. propositional, attributive, first-order, or even higher order ones) or performed on the basis of engineering intuition. Rule-based systems have found numerous applications in various domains of engineering, science, medicine, law, computer science and application software (Laffey and *et al.*, 1988; Liebowitz, 1998).

The never-ending story of rule-based systems started with the very first attempts to formally codify rules of human behavior. Perhaps one of the best known set of such rules, the *Ten Commandments*, have been with us since the times of Moses (see (Ligeża, 2006) for a more detailed historical review).

Rules are omnipresent in our everyday life, professional work, leisure and sport activities. They are result of physical (and mathematical) laws, formed by men, tradi-

tion, culture, civilization. The most precise rules are the ones found in technical and technological systems, however many rule-based expert systems addressed the issues of medical diagnosis or business decision support as well.

In engineering, the first examples of rule-based systems are the ones concerning feedback control with a two-position or three-position rely; in fact, such systems can be considered a simple, hard-wired rule-based systems. Further examples come from the domain of digital circuits. In fact, any combinatorial circuit can be regarded as a propositional logic rule-based system.

In computer science rule-based systems appeared just after symbolic programming languages had been developed. First such systems were termed *production systems* or *production rules* (Brownston, Farrell, Kant and Martin, 1985; Liebowitz, 1998). The golden age for rules came in the late seventies and eighties with developments and practical applications of expert systems. They were dedicated to solving specific problems in narrow, well-formalized domains. A typical construction of such a system was based on two components: a *declarative rule-base* encoding domain-specific knowledge and an *inference engine* of general purpose, the so-called *expert sys-*

tem shell (Liebowitz, 1998; Giarratano and Riley, 2005).

Modern shells for development of rule-based systems, such as CLIPS, Jess, Drools, Aion, Ilog Rules, G2 of Gensym, follow this classical paradigm. Rules are developed using some predefined knowledge representation framework (often close to attributive logic). The current rule-based systems and tools for their development have reached a certain level of maturity. Specialized editors that enforce correct structure and are capable of checking the syntax of rules are in use and provide tools for computer-aided development of final applications. On the other hand, they have inherited a number of traditional features of early rule-based systems, which nowadays can be considered as drawbacks.

In this paper we mainly address the following issues, which seem worth investigation and improvement:

sparse representation – single rules constitute items of low knowledge processing capabilities, while for practical applications a higher level of abstraction is desirable,

blind inference – inference engines, especially forward-chaining ones, are highly inefficient with respect to the focus on the goal to be achieved,

lack of methodology – no practical methodology for consecutive top-down design and development of rule-based systems, acceptable by engineers and ensuring quality of rules is available.

This paper presents a new approach to design and development of rule-based systems. More precisely, we present the state-of-the-art of the HeKatE methodology¹, for design and development of complex rule-based systems for control and decision support. This methodology is supported with visual tools for development of knowledge bases and novel inference engine.

The main paradigm for rule representation, namely the eXtended Tabular Trees (XTT) (Nalepa, 2004; Nalepa and Ligeza, 2005a), ensures high density and transparency of visual knowledge representation. Contrary to traditional, flat rule-based systems, the XTT approach is focused on *groups of similar rules* rather than single rules. In this way we address the first issue of low processing capabilities of single rules. Such groups form decision tables which are connected into a network for inference.

Efficient inference is assured thanks to firing only rules necessary for achieving the goal. It is achieved by selecting the desired output tables and identifying the tables necessary to be fired first. The links representing the partial order assure that when passing from a table to another one, the latter can be fired since the former one prepares an appropriate context knowledge. Hence, only

rules working in the current context of inference are explored. The partial order between tables allows to avoid examining rules which should be fired later.

Another distinctive feature is the design methodology allowing for formal verification of rules. A top-down design methodology based on successive refinement of the project is introduced. It starts with development of an Attribute Relationship Diagram (ARD) which describes relationships among process variables. Based on the ARD model, a scheme of particular tables and links between them are generated. The tables are filled with expert-provided definitions of constraints over the values of attributes; these are in fact the rule preconditions. The code for rules representation is generated and interpreted with provided inference engine. A set of tools supporting the design and development stages is described in brief.

The rest of the paper is organized as follows. In Sec. 2 the perspective on the rule-based systems applications for intelligent control is given. For intuition, a simple example concerning the rely-type controller is used to identify some of the most important issues tackled in this paper. This gives a background for the motivation for the research, as discussed in Sec. 3, and the HeKatE project, which aims at providing solutions for the problems of sparse representation, blind inference, lack of methodology, identified in this section. One of the main goals of the project is to provide a new rule-based inference engine solution assuring flexible and efficient control during the inference process. In Sec. 4, the dynamic systems state representation discussion is given in order to be able to develop a formalization for rules. Rules in HeKatE are formalized with the use of *attributive logic*, introduced in Sec. 5 and then discussed in an extended version in Sec. 6. Inference rules for the attributive logic formulae are presented in Sec. 7. They allow for firing XTT rules grouped into tables. The table level inference is discussed in Sec. 8. The practical design of the XTT knowledge bases is supported by visual editors, and other tools is shortly presented in Sec. 9. A concise comparison to the related solutions is given in Sec. 10. Finally the future challenges for the methodology are given in Sec. 11.

2. Rule-Based Intelligent Control

This section is addressed to the *automatic control* audience. It briefly shows how rules can be used to provide declarative means for building controllers in a wide sense of the word *control*. In fact, the past, current, and prospective applications are allocated in numerous, diversified areas of applications, ranging from direct (digital) control, meta-level control, decision support, business rules applications and various forms of expert systems (Laffey and *et al.*, 1988; Liebowitz, 1998).

¹An acronym for Hybrid Knowledge Engineering, see <http://hekate.ia.agh.edu.pl>

2.1. Explaining the Ideas of Rules in Control. Consider a simple case of a direct use of rules for control. Rules can be used to specify rely-type controller of many levels (not just two-level or three-level classical control rely). In fact, an arbitrary approximation of any nonlinear characteristic of the controller can easily be specified.

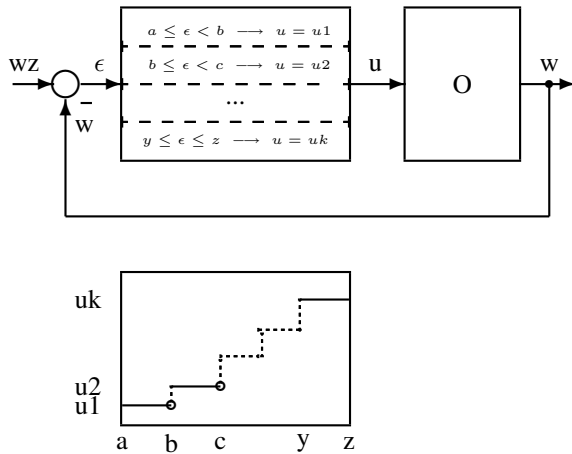

Fig. 1. A simple application of a rule-based system as a direct controller

This type of application is illustrated in Fig. 1. In the picture, u is the input of the object under control and w is its output signal. The current value of the control error, ϵ is calculated as $\epsilon = wz - w$, where wz is the required set point. Depending on the value of ϵ the rule-based controller determines the level of the u signal, according to the characteristics shown in Fig. 1.

Obviously, applying a rule-based system as a direct controller is not the only way to make use of the rule-based systems technology. In fact, a rule-based approach can be applied to decision making, optimization (selection of optimal settings or trajectories), adaptation (adjusting the algorithms or parameters to new conditions), and even determining structural changes of the control system. These ideas are illustrated in Fig. 2.

2.2. Rule-Based Control and Decision Support. Perhaps one of the first successful applications of the rule-based methodology applied to real-time control was the Ventilator Manager (VM) (Fagan, Kunz and Feigenbaum, 1979; Fagan, 1980). This system was applied to read and interpret online physiological data in an intensive care unit. On-line monitoring of 30 physiological measurements was performed at 2 or 10 minutes time intervals, constituting the input of the system. As the output, the system produced suggestions to clinicians and periodic report summaries.

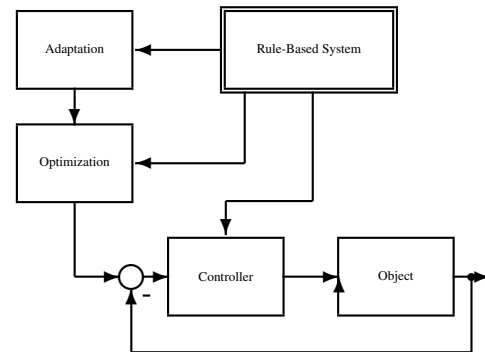

Fig. 2. Application of rule-based systems at various level of multi-level control: direct control, optimization, and adaptation.

Another important step in development of the rule-based system applications in control was the design of the Rete algorithm (Forgy, 1982). The algorithm is based on two observations: (i) at each cycle, only few facts of the fact base change (this is referred to as *temporal redundancy*), and (ii) preconditions of rules often contain similar patterns or groups of such patterns (this is referred to as *structural similarity*) (Giarratano and Riley, 2005). Hence, instead of repeated checking of preconditions of *all* the rules at each cycle, the Rete algorithm employs a specialized network for fast indexing of changes in the fact-base and their influence on satisfaction of the rule preconditions. Thanks to the application of Rete, sets of rules which can be fired can be determined in an efficient way. Such sets are called *conflict sets*, since only one of the rules can be fired.

Rete-type identification of rules that can be fired is memory consuming, since the Rete network can be quite large. On the other hand, if efficiency is of primary importance, application of Rete forward-chaining inference engine seems reasonable (especially in real-time control applications). Nevertheless, such forward checking procedure does not identify which rules should be fired so as to achieve the goal. As many unnecessary rules can be fired, we shall refer to the inference scheme as a *blind* one.

The next important step was the development of CLIPS (Giarratano and Riley, 2005) (an acronym for C Language Integrated Production System), a descendant of the OPS5 (Brownston *et al.*, 1985), a rule-based production system written in Lisp. CLIPS was developed by NASA and – despite being developed in C – it follows the Lisp-like style of knowledge specification (a bit clumsy; full of parentheses and hardly readable for en-

gineers). It has become perhaps one of the most popular rule-based engines, since it is relatively fast (employing the Rete algorithm (Forgy, 1982)), simple, and free (now in the public domain). A more recent reincarnation of CLIPS is Jess (Java Expert System Shell) (Friedman-Hill, 2003), developed in Java, but still employing the a bit ancient Lisp-like style of rules encoding. Another example is Drools (Browne, 2009), also referred to as a *Business Rules Management System*. All the systems are in principle blind, forward-checking ones, employing advanced implementations of the Rete-based inference engines.

Wider application of the technology of rule-based systems in the domain of automatic control started in the eighties, as soon as the technology itself has reached some maturity. A good survey from that times is provided in (Laffey and *et al.*, 1988). The Authors report numerous successful applications in domains ranging from aerospace, through communications, process control, and robotics, to medicine.

Some overview of current developments with respect to theory, knowledge representation, tools and application areas is provide in (Liebowitz, 1998). A list of current tools is enclosed at the back of (Ligęza, 2006). A very recent book (Giurca, Gasevic and Taveter, 2009) gives a good overview of some emerging technologies and tools in the area of rule-based solutions.

2.3. Rule-Based Control and Decision Support. Historical Perspective of the Research towards the XTT Approach. Authors' research in the domain of rule-based systems for control started in 1986 (Ligęza, 1986). The aim was to develop specialized form of rules taking into account the specific requirements of the control domain. This resulted in development of some universal rule scheme incorporating dynamic modification of the knowledge base (through *retract* and *assert* operations)² and elements of control (the concept of declaring the *next*, and *else* rules). The rules were designed to work only within a certain *context*, *status* and *mode* which focused the inference on the subset of rules necessary for current stage of inference (Tzafestas and Ligęza, 1988; Tzafestas and Ligęza, 1989).

On the other hand, application of rules for decision support in business processes was addressed in (Ligęza, 1988). It was pointed out that there are different kinds of rules for different purposes (pure deduction, dealing with numerical values, domain-independent properties, meta rules for control).

In order to ensure reliability, safety and quality of rule-based systems, additional work on verification of theoretical properties was carried out (Ligęza, 1993). A new

²These names follow the Prolog (Bratko, 2000) language notation, and corresponds to removing and adding facts to the fact base.

inference rule, the so-called *backward dual resolution* (or *dual resolution*, for short) was invented for logical verification of completeness of rule-based systems. A taxonomy of abnormalities and approaches to deal with them was discussed in (Ligęza, 1999).

A comprehensive report on trends and directions of research was presented in (et. al, 2000). Some breakthrough ideas were introduced in (*Logical Support for Design of Rule-Based Systems. Reliability and Quality Issues*, 1996), namely a proposal to incorporate the verification in the design stage, so that it is performed on-line and not only after the system is developed. Another idea was to group similar rules together (to form tabular components covering several rules instead of one) and to perform verification of such tables of similar rules rather than a flat set of all the rules (Ligęza, 1998).

An initial concept of organization of tabular system into a hierarchical structure was first proposed in (Ligęza, 2001), and developed as a practical test-bed implementation under the name of Tab-Trees (Ligęza, Wojnicki and Nalepa, 2001). The first *conceptual statement*, some basic formalism and initial working implementation of the XTT were developed as a Ph.D. project and presented in (Nalepa, 2004). They were later described in (Nalepa and Ligęza, 2005a) on the conceptual level. The Mirella tools supporting the visual XTT design have been introduced in (Nalepa and Ligęza, 2005c). To support the logical XTT design, the ARD method has been introduced later on in (Nalepa and Ligęza, 2005b). A survey in the form of a textbook presenting logical foundations and developments in the area of attribute logic, its application in XTT and elements of design and verification methodology were the objectives of (Ligęza, 2005) and (Ligęza, 2006). A Prolog implementation for XTT has been discussed in (Nalepa and Ligęza, 2006). The presented above developments and experience gained during the research form the foundations that led to the *HeKatE* methodology being the focus of this paper.

3. HeKatE Approach

3.1. Motivation. Certain persistent limitations of the existing approaches to the design of rule-based intelligent control systems exist. They are especially visible in the case of designing complex systems. They often make the high quality design as well as the refinement of such systems very difficult. These limitations are related to the following aspects of rule design:

- *knowledge representation* – where rules are informally described and lack clear semantics,
- *transparent structure and efficient inference in the rulebase* – where the focus on the design of single rules, with no structure explicitly identified by the

user, makes the hierarchization of the model very difficult; moreover the classic massive inference mechanisms such as the Rete algorithm do not address the contextual nature of the rulebase,

- *well founded systematic and complete design process* – that preserves the quality aspects of the rule model, and allows for gradual system design and automated implementation of rules.

These issues are discussed in more detail in the following subsections.

The majority of rule-based systems work according to the classical principles of *forward chaining*. They incorporate a relatively simple, blind inference engine. In order to speed-up the interpretation of rules they often employ some indexing of changes that occur in the fact base, and the way they influence the rule preconditions satisfaction, e.g. the Rete network.

With respect to the knowledge representation language being used the following issues may be raised:

- lack of formal relation of the knowledge representation language to classical logic, consequently
- difficulties with understanding the expressive power of the language,
- lack of standards for knowledge representation, and, as a consequence
- lack of knowledge portability.

With respect to the internal structure and inference mechanism the criticism may be even stronger:

- typically, the set of rules is flat – it has no internal structure, so hundreds of different rules are considered equally important, and equally unrelated,
- the inference engine (at least potentially) tries to examine all rules in turn for firing within every cycle,
- it is unclear if the Rete network can be efficiently used in case of knowledge representation formalism of higher expressive power³,
- there is no definite way to select which rules from the conflict set should be fired,
- irrelevant rules can be fired even if they do not contribute to the problem solution.

With respect to the development methodology it should be pointed out that most of the rule-based tools are just shells providing a rule interpreter and sometimes an editor. Hence:

³For example, in case of First Order Logic one cannot avoid using a complete unification algorithm, which itself is based on a tree matching procedure. The Authors are unaware of any research on application of Rete for speeding-up term unification.

- the knowledge acquisition task constitutes a bottleneck and is arguably the weakest point in the design and development process,
- typical rule shells are not equipped with consistent methodology and tools for efficient development of the rule base; on the other hand, general methodologies such as KADS or Common-KADS (van Harmelen, 1996) are too complex for practical engineering or business applications,
- verification of the knowledge is rarely supported, and, if supported
- verification is performed only after the rule design (so knowledge refinement can introduce new errors).

3.2. Main principles. Three main principles following from the above analysis define the foundations of the approach advocated in this paper:

1. **Formal Language Definition** — we insist on a precise definition of a formal language, its formal properties and inference rules. This is crucial for determining the expressive power, definition of inference mechanism and solving verification issues;
2. **Internal Knowledge Structure** — we introduce internal structure of the rule base. Similar rules, aimed at working within a specific context, are grouped together and form the XTT tables. These tables are linked together forming a partially ordered graph structure (possibly with cycles); which encodes the flow of inference;
3. **Systematic Design Procedure** — we argue for a complete, well-founded design process that covers all of the main phases of the system life-cycle, from the initial conceptual design, through the logical formulation, all the way to the physical implementation. We emphasize the need for a constant on-line verification of the system model w.r.t. critical formal properties, such as determinism and completeness.

These principles served as guidelines for the *HeKatE* approach we introduce in the next section.

3.3. Goals and Perspectives. The goals of the *Hybrid Knowledge Engineering* (HeKatE) methodology correspond to the principles described previously in Sec. 3.2. The rule-based knowledge is decomposed into multiple modules represented by attributive decision tables (the so-called *object-attribute-value* tables, see (Ligeza, 1996; Ligeza *et al.*, 2001)) The controller is designed using the *HeKatE* methodology. So the main goals are to provide: an expressive formal logical calculus for rules, allowing for formalized inference and analysis, a structured visual

rule representation method with formally described syntax and semantics, based on decision tables, and a complete hierarchical design process based on the above, with an effective on-line verification methods as well as, automated implementation facilities.

The emphasis of the methodology is its possible application to a wide range of intelligent controllers. In this context two main areas have been identified in the project:

- control systems, in the field of intelligent control (Laffey and *et al.*, 1988; Cheng, 2002),
- business rules (von Halle, 2001; Ross, 2003) and business intelligence systems (Morgan, 2002).

Taking into account the first domain of application, the meaning of the term “controller” is straightforward, and falls into the area discussed in this paper as *intelligent control* in as a kind of automatic control.

In case of the second domain the term denotes a well isolated software component implementing the so-called application logic, or logical model. In business software this component is commonly integrated using a dedicated architectural pattern, such as the *Model-View-Controller* (Burbeck, 1992; Gamma, Helm, Johnson and Vlissides, 1995). In this pattern the components of the system are divided into three main groups:

- *Model* – that provides the main control logic,
- *View* – which roughly corresponds to system interfaces, in a broad sense, and the
- *Controller* – which connects these two in a flexible way (in this case, the term “controller” is used in a purely technical meaning).

In fact, in real life applications, number of *Views* (possibly with different *Controllers*) are provided for the same logical *Model*, to allow the reuse of the same control logic in number of applications.

Let us now present the first perspective using an example.

3.4. Intuitive Example. In order to explain the ideas underlying the presented approach, let us refer to the classical scheme of feedback control, as widely known in the domain of control theory. It is assumed that there is given a certain (dynamic) *system under control* and another system – in our case the *XTT System* playing the role of an intelligent controller. A general scheme is presented in Fig. 3.

The system under control has some input and some observable output. Both the input and the output can be encoded in some symbolic form (meaningful numbers, symbols, facts, logical formulae, etc.). Hence, both input and output streams can be of numerical and symbolic

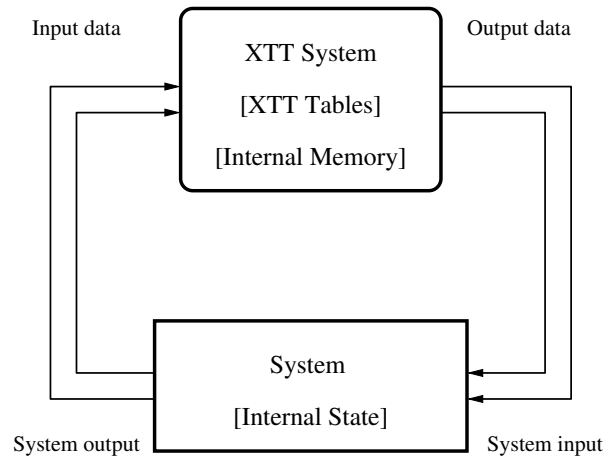

Fig. 3. The scheme of closed-loop feedback control

form. The system possesses memory, therefore one can speak about some *internal state* describing the cumulated results of former input and allowing to model its future behavior.

As input data the XTT system receives the output from the system under control. With use of the internal knowledge (a kind of a rule-base), the XTT system works out some output data (decisions, control) and sends it as the input to the system under control.

The system under control can be, in general, almost any complex system providing observable (measurable) and meaningful output. It can be a complex technological installation, computer hardware or software, a database, a knowledge-base, or a natural or artificial system with manual formation of the XTT input. The task performed by the XTT system can range from direct, closed-loop control, to monitoring, decision making or knowledge processing.

The main focus of this paper is on the XTT system, its components (tables of rules), internal structure, knowledge representation language and inference, as well as inference control and design issues. The XTT system is composed of some number of attributive decision tables extended with regard to simple decision tables known in literature (Pawlak, 1991). To provide some intuitions of how such a system is built and how it works look at Fig. 4.

The system from Fig. 4 is devoted to inferring the price per minute for telephone calls, depending on the time of a day and size of the client company. There are three decision tables. The first one allows to determine the period of a day; the output attribute *aPeriod* takes one of three possible values: business hours (*bh*), afternoon hours (*ah*), or night hours (*nh*). The input attribute here is the time (*aTime*), e.g. as read from the system clock. The second decision table defines the qualitative size of the company and takes the following values: *small* (between 1 and 10 lines), *medium* (between 11 and 30 lines)

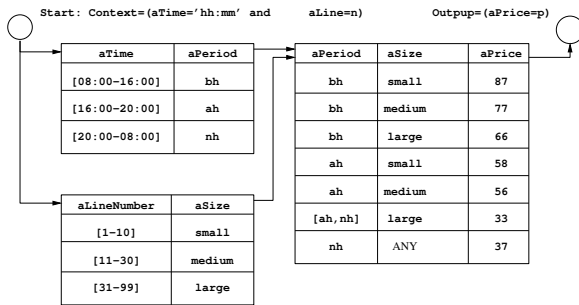

Fig. 4. A simple intuitive example of an XTT system

and large (between 31 and 99 lines). After having determined the period and the size, the values of attributes `aPeriod` and `aSize` are used to infer the prices; various combinations of period and size and the corresponding price are defined in the third table.

The system can start its work given the values of `aTime` and `aLineNumber` attributes as its input; in other words, the values of these attributes – when defined – determine the *context* of the work of the XTT system. The appropriate rules are activated when control is passed to a specific table. Contrary to classical solutions rules are fired when necessary, not when only the preconditions are satisfied. The links among tables define a partial order of inference. Within a table a single rule or a set of rules can be fired. As shown with this simple example, some tables can be interpreted *in parallel* (in our example the first two tables), while the third one must be interpreted *after* producing output of both of them.

3.5. Review of the Methods. In the HeKatE project a formalized language for an extended rule representation is introduced. Instead of simple propositional formulae, the language uses expressions in the so-called *attributive logic* (Ligeza, 2006). This calculus has higher expressive power than the propositional logic, while providing tractable inference procedures for extended decision tables (Ligeza and Nalepa, 2007; Ligeza and Nalepa, 2008). The current version of the rule language is called XTT² (Nalepa and Ligeza, 2008). The logical formalism, adopted for the XTT² language, is called ALSV(FD) (*Attributive Logic with Set Values over Finite Domains*). The details of this solution are discussed in extent in Sections 5, and 6.

Based on the attributive logic the XTT rule language is provided (Nalepa, 2004; Nalepa and Ligeza, 2005a; Nalepa and Ligeza, 2008). XTT stands for *eXtended Tabular Trees*, since the language is focused not only on providing an extended syntax for single rules, but also allows for an explicit structurization of the rule base. This solution allows for identifying system contexts during the rule base design. XTT introduces explicit inference control solutions, allowing for a fine-grained and more op-

timized rule inference than in the classic Rete-like solutions. XTT has been introduced with the visual design support in mind. The representation has a compact and transparent representation suitable for visual editors.

The HeKatE project also provides a complete hierarchical design process for the creation of the XTT-based rules. The process is based on the ideas originally introduced in (Nalepa, 2004). The main phase of the XTT rule design is called the *logical design*. This phase is supported by a CASE tool called HQed (Kaczor and Nalepa, 2008; Kaczor, 2008).

The logical rule design process may be supported by a preceding *conceptual design* phase. In this phase the rule prototypes are built with use of the so-called *Attribute Relationship Diagrams*. The ARD method has been introduced in (Nalepa and Ligeza, 2005b), and later refined in (Ligeza, 2006). The principal idea is to build a graph, modelling functional dependencies between attributes on which the XTT rules are built. The version used in HeKatE is called ARD+. The ARD+ design is supported by two visual tools, VARDA and HJed.

The practical implementation on the XTT rule base is performed in the physical design phase. In this stage the visual model built with HQed is transformed into an algebraic presentation syntax. A custom inference engine then can run the XTT model. All of these design tools are described in more detail in Sec. 9.

4. State Representation

When processing information, the current values of attributes form the *state of the inference process*. The values of attributes can, in general, be modified in the following three ways:

- by an independent, external system,
- by the inference process itself, and
- as some time-dependent functions.

The first case concerns attributes representing some process variables, which are to be taken into account in the inference process, but depend only on the environment and external systems. As such, the variables cannot be directly influenced by the XTT system. Examples of such variables may be the external temperature, the age of a client or the set of foreign languages known by a candidate. Values of those variables are obtained as a result of some *measurement* or *observation* process, and are assumed to be put into the inference system via a *blackboard* communication method; in fact they are written directly into the internal memory whenever their values are obtained or changed.

A special group of such externally provided values of attributes are the so-called *askable* attributes. A question is posed to the user and an answer (from a limited set of

possibilities) is provided. Extension of this ideas consist in gathering such values in an external database accessed by the rule-based system.

The second case concerns the values of attributes obtained at certain stage of reasoning as the result of the operations performed in decision part (the so-called right hand side, RHS) of XTT. The new attribute values can be:

- asserted to global memory (hence stored and made available for other components of the system), or
- kept as values of internal process variables.

The first solution is offered mostly for permanent changes of global values; before asserting new values typically an appropriate retract operation is to be performed so as to keep a consistent state. In this way also the history (trajectory) of the system can be stored, provided that each value of an attribute is stored with a temporal index. The second (potential) solution may offer another method for value passing and calculations which do not require permanent storage. For example, if a calculated value is to be passed to another XTT component and it is no longer used afterwards, it is not necessary to store it in the global memory. The second possibility is not implemented in the current version of the XTT system.

4.1. Requirements for the State Representation.

The current state of the system is considered as a complete set of values of all the attributes in use at a certain instant of time. The concept of the state is similar to the one in dynamic systems and state-machines. The state representation should satisfy important requirements. It should be: (i) *internally consistent*, (ii) *externally consistent*, (iii) *complete*, (iv) *deterministic*, and (v) *concise*.

The first postulate says that the specification itself cannot be inconsistent at the syntactic level. For example, a *simple attribute* (one taking a single value) cannot take two different values at the same time. In general, assuming independence of the attributes and no use of explicit negation, each value of an attribute should be specified exactly once.

A *generalized attribute* is one taking a set value (see Sec. 6). In case of such attributes their values are represented by sets (e.g. with use of lists) and undergo the same restrictions.

The second postulate says that only *true* knowledge (with respect to the external system) can be specified in state. In other words, facts that are syntactically correct but false cannot occur in the state formula.

The third postulate says, that *all* the knowledge that is true at a certain instant of time should be represented within the state. This also means that the size (w.r.t. the number of attributes) of the state representation can vary over time, since at certain time instants the values of certain attributes can remain undefined.

The fourth postulate says that there can be no disjunctive or conditional knowledge specification.

Finally, the fifth postulate says that no unnecessary, dependent knowledge should be kept in the state. In databases (Connolly, Begg and Strechan, 1999) and most of the knowledge bases this has a practical dimension: only true facts are represented explicitly. On the other hand, note that we insist that *all* the known values of attributes are present, i.e. the specification is complete. If there are some functional dependencies among attributes, the only way to represent them is to encode them with the XTT components, and once the dependent value is deduced, it is placed in the state. This also means, that if some of the values are changed, we can have a temporarily inconsistent state (a transitional situation), until the new values of the dependent attributes are inferred and they replace the old ones.

4.2. State Specification. The current values of all attributes are specified within the contents of the knowledge-base (including current sensor readings, measurements, inputs examination, etc.). From logical point of view the state is represented as a logical formula:

$$(A_1 = S_1) \wedge (A_2 = S_2) \wedge \dots \wedge (A_n = S_n) \quad (1)$$

where A_i are the attributes and S_i are their current values; note that $S_i = d_i$ ($d_i \in D_i$) for simple attributes and $S_i = V_i$, ($V_i \subseteq D_i$) for complex ones, where D_i is the domain for attribute A_i , $i = 1, 2, \dots, n$. (see Sec. 6 for the discussion of attribute types).

In order to cover realistic cases an explicit notation for covering unspecified, unknown values is proposed; for example to deal with the data containing the NULL values imported from a database. Consider a case when an attribute may be applied to an object, but it takes no value. This will be denoted as $A = \emptyset$. For example, the formula `Phone_Number= \emptyset` means that the considered person has no phone number. Finally, a formula of the form $A = \text{NULL}$ means that attribute A takes an unspecified value.

States can be identified by a key, described with some comments (key words, characteristics) and indexed with time instant (or interval). Such states can be stored for enabling access to past/historical values, monitoring the trajectory of the system and changes of the fact base. Recorded states are analogous to save points in databases and can be used to repeat inference and retrieve current state in case of system failure. More on that can be found in the Sec. 8.

In the next sections the logic allowing for the state representation and inference is introduced.

5. Attributive Logic

5.1. Basics of Attributive Languages. Using logics based on attributes is one of the most popular approaches to define knowledge. Not only it is very intuitive, but it follows simple technical way of discussion where the behavior of physical systems is formalized by providing the values of system variables. This kind of logic is omnipresent in various applications. It constitutes the bases for construction of relational database tables (Connolly *et al.*, 1999), attributive decision tables and trees (Klösger and Żytkow, 2002; Pawlak, 1991; Quinlan, 1986), attributive rule-based systems (Ligeza, 2006) and is often applied to describe state of dynamic systems and autonomous agents. Some most typical examples include expert systems and decision support, rule-based control and monitoring systems, and diagnostic systems.

However, it is symptomatic that while a number of modern rule-based shells, such as Jess or Drools, provide new high-level features in the area of current software technologies, such as Java-integration, network services, etc., the rule representation and inference methods do not evolve. The rule languages found in these tools tend to be logically trivial, and conceptually simple. They mostly reuse very basic logic solutions, and combine them with new programming language features, mainly borrowed from Java, building on top of classic inference approaches, such as the blind, forward-checking inference engines employing the Rete-style algorithm (Forgy, 1982).

While these systems integrate well with today business application stacks, they provide little or no improvement in the areas of formalized analysis, visual design, gradual refinement or inference control. This gives motivation to approach these problems by introducing novel knowledge representation and design tools.

It is symptomatic that although Propositional and Predicate Logic (in the form of First-Order Predicate Calculus) have well-elaborated syntax and semantics, presented in details in numerous books covering logic for AI and knowledge engineering (Genesereth and Nilsson, 1987; Jackson, 1999; Torsun, 1995), logic for computer science or Artificial Intelligence (Ben-Ari, 2001; Liebowitz, 1998), the discussion of syntax and semantics of attribute-based logic is omitted in such positions.⁴

On the contrary, apparently it is often assumed, that attributive logic is some kind of *technical language* equivalent with respect to its *expressive power* to propositional calculus, and as such it is not worth any more detailed discussion. Actually, it seems that some of the real reasons for the omission of the presentation is that a more detailed discussion might be not so straightforward, concise and elegant as in the case of classical logics.

In fact, as it follows from some first attempts presented in (Ligeza, 2006) this issue requires a more detailed

study. The most typical way of thinking about attributive logic for knowledge specification may be put as follows:

- first, one has to define *facts*, typically of the form

$$A = d$$

or

$$A(o) = d,$$

where A is a certain attribute, o an object of interest and d is the attribute value.

- second, facts are perceived as propositional logic atomic formulae,
- third, the syntax and semantics of propositional calculus are freely used.

This basic approach is sometimes extended with use of certain syntax modifications. For example, in (Klösger and Żytkow, 2002) the discussion is extended, so that the rules take the form:

$$A_1 \in V_1 \wedge A_2 \in V_2 \wedge \dots \wedge A_n \in V_n \longrightarrow A_{n+1} = d.$$

Following this line of extended knowledge specification, various relational symbols can be introduced, e.g. $A_i > d$ (for ordered sets; this can be considered as a shorthand for $A_i \in V_i \setminus V_d$, where V_d is the set of all the values of A_i less than or equal to d) or $A_i \neq d_i$ (this can be considered as a shorthand for $A_i \in V_i \setminus \{d_i\}$).

Note however, that extending the syntax in such a way preserves the limitation that an attribute can only take a single value at a time. Further, without providing a clearly defined semantics for the language and some formal inference rules, it may lead to severe problems. This follows from the fact that atoms do not appear to be *logically independent* any longer (which is the basic, although often implicit assumption of propositional logics (Ligeza, 2006)). For example, having a rule such as

$$Temperature > 100 \longrightarrow WaterState = boiling$$

and a fact like $Temperature > 123$, we would not be able to fire the rule using classical inference rules.⁵

6. Set Attributive Logic (SAL) Development

In a recent book (Ligeza, 2006) the discussion of attributive logic is much more thorough. The added value consist in allowing that attributes can take *set values* and providing some formal framework of the *Set Attributive Logic*

⁴Note that even in the four-volume handbook of *Logics for Artificial Intelligence* edited by D.Gabbay *et al.* the *Attribute Logic* has not deserved a few pages of formal presentation and analysis of properties.

⁵Well, some expert system shells, such as PC-SHELL (see <http://aitech.pl/>) are capable of performing the so-called *intelligent unification* and hence succeed to carry on with this kind of inference; this has however nothing to do with logic, it is just a hard-wired implementation of a specialized match mechanism which works only for predefined symbols.

(SAL) with respect to its syntax, semantics and selected inference rules. The very basic idea for further discussion is that attributes should be able to take not only *atomic* but *set* values as well.

After (Ligęza, 2006) it is assumed that an *attribute* A_i is a function (or partial function) of the form $A_i: O \rightarrow D_i$. Here O is a set of objects and D_i is the domain of attribute A_i .

As we consider dynamic systems, the values of attributes can change over time (or state of the system). We consider both *simple* attributes of the form $A_i: T \rightarrow D_i$ (i.e. taking a single value at any instant of time) and *generalized* ones of the form $A_i: T \rightarrow 2^{D_i}$ (i.e. taking a set of values at a time); here T denotes the time domain of discourse.

The atomic formulae of SAL can have the following four forms:

$$A(o) = d, \quad (2)$$

$$A(o) = t, \quad (3)$$

$$A(o) \in t \quad (4)$$

and

$$A(o) \subseteq t \quad (5)$$

where $d \in D$ is an atomic value from the domain D of the attribute and $t \subseteq D$, $t = \{d_1, d_2, \dots, d_k\}$, is a (finite) set of such values. If the object o is known (or unimportant) its specification can be skipped; hence we write $A_i = d$, $A_i = t$, $A_i \in t$ or $A_i \subseteq t$, for simplicity.

The semantics of $A_i = d$ is straightforward – the attribute takes a single value. The semantics of $A_i = t$ is that the attribute takes *all* the values of t while the semantics of $A_i \in t$ is that it takes exactly *one* value from t and, finally, $A_i \subseteq t$ means that the attribute takes *some* of the values of t (the so-called *internal disjunction*)⁶.

In the case of (3) and (5) A is the so-called *generalized attribute* (Ligęza, 2006). From now on, we will refer to both types of attributes as just attributes.

As an example for the necessity of SAL one can consider the specification of working days (denoted with $WDay$) given as: $WDay = \{Monday, Tuesday, Wednesday, Thursday, Friday\}$. Now one can construct an atomic formula like $DaysOfInterest \subseteq WDay$, or a rule of the form: $DaysOfInterest \subseteq WDay \rightarrow Status(OfficeOfInterest) = open$.

The SAL as introduced in (Ligęza, 2006) seems to be an important step towards the study and extension of attributive logics towards practical applications. On the other hand it still suffers from lack of expressive power and the provided semantics of the atomic formulae is poor.

In this paper an improved and extended version of SAL is presented in brief, namely Attributive Logic with

⁶For uniformity, single elements can be considered as single-element sets; hence (4) can be replaced with (5) if it is not misleading.

Set Values over Finite Domains (ALSV(FD)), first introduced in (Ligęza and Nalepa, 2007; Nalepa and Ligęza, 2008). For simplicity no objects are specified in an explicit way. The formalism is oriented towards Finite Domains (FD) and its expressive power is increased through introduction of new relational symbols. The semantics is also clarified. The practical representation and inference issues both at the logical level and implementation level are tackled. The main extension consists of a proposal of extended set of relational symbols enabling definitions of atomic formulae. The values of attributes can take singular and set values over Finite Domains (FD).

6.1. ALSV(FD). The basic element of the language of *Attribute Logic with Set Values over Finite Domains* (ALSV(FD) for short) are attribute names and attribute values. Let us consider:

A – a finite set of attribute names,

D – a set of possible attribute values (their *domains*).

Let $\mathbf{A} = \{A_1, A_2, \dots, A_n\}$ are all the attributes such that their values define the state of the system under consideration. It is assumed that the overall domain \mathbf{D} is divided into n sets (disjoint or not), $\mathbf{D} = D_1 \cup D_2 \cup \dots \cup D_n$, where D_i is the domain related to attribute A_i , $i = 1, 2, \dots, n$. Any domain D_i is assumed to be a finite (discrete) set. The set can be ordered, partially ordered, or unordered.

Let A_i be an attribute of \mathbf{A} and D_i the sub-domain related to it. Let V_i denote an arbitrary subset of D_i and let $d \in D_i$ be a single element of the domain. The legal atomic formulae of ALSV along with their semantics are presented in Tab. 1, and Tab. 2 for simple and general attributes.

In case V_i is an empty set (the attribute takes in fact no value) we shall write $A_i = \emptyset$. In case the value of A_i is unspecified we shall write $A_i = \text{NULL}$ (a database convention). If we do not care about the current value of the attribute we shall write $A = _$ (a PROLOG convention).

More complex formulae can be constructed with *conjunction* (\wedge) and *disjunction* (\vee); both of these the symbols have classical meaning and interpretation.

There is no explicit use of negation. The proposed set of relations is selected for convenience and as such they are not completely independent. For example, $A_i = V_i$ can perhaps be defined as $A_i \subseteq V_i \wedge A_i \supseteq V_i$; but it is much more concise and natural to use just “=” directly. Various conventions extending the basic notation can be used. For example, in case of domains being ordered sets, relational symbols such as $>$, \geq , $<$, \leq can be used with the straightforward meaning.

The semantics of the proposed language is presented below in an informal way. The semantics of $A = V$ is basically the same as the one of SAL (Ligęza, 2006). If $V = \{d_1, d_2, \dots, d_k\}$ then $A = V$ the attribute takes

Table 1. Simple attribute formulae syntax

Syntax	Interpretation: true if...	Relation
$A_i = d$	the value is precisely defined	eq
$A_i \in V_i$	the current value of A_i belongs to V_i	in
$A_i \neq d$	shorthand for $A_i \in D_i \setminus \{d\}$.	neq
$A_i \notin V_i$	is a shorthand for $A_i \in D_i \setminus V_i$.	notin

Table 2. Generalized attribute formulae syntax

Syntax	Interpretation: true if...	Relation
$A_i = V_i$	equals to V_i (and nothing more)	eq
$A_i \neq V_i$	is different from V_i (at at least one element)	neq
$A_i \subseteq V_i$	is a subset of V_i	subset
$A_i \supseteq V_i$	is a superset of V_i	supset
$A \sim V$	has a non-empty intersection with V_i	sim
$A_i \not\sim V_i$	has an empty intersection with V_i	notsim

all the values specified with V (and nothing more). The semantics of $A \subseteq V$, $A \supseteq V$ and $A \sim V$ is defined as:

$$A \subseteq V \equiv A = U$$

for some U such that $U \subseteq V$, i.e. A takes *some* of the values from V (and nothing out of V),

$$A \supseteq V \equiv A = W,$$

for some W such that $V \subseteq W$, i.e. A takes *all* of the values from V (and perhaps some more), and

$$A \sim V \equiv A = X,$$

for some X such that $V \cap X \neq \emptyset$, i.e. A takes *some* of the values from V (and perhaps some more). As it can be seen, the semantics of ALSV is defined by means of relaxation of logic to simple set algebra.

6.2. XTT Rules in ALSV(FD). Consider a set of n attributes $\mathbf{A} = \{A_1, A_2, \dots, A_n\}$. Any XTT rule is assumed to be of the form:

$$(A_1 \alpha_1 V_1) \wedge (A_2 \alpha_2 V_2) \wedge \dots \wedge (A_n \alpha_n V_n) \longrightarrow RHS$$

where α_i is one of the admissible relational symbols in ALSV(FD), and RHS is the right-hand side of the rule (RHS) covering conclusions. In practise the conclusions are restricted to assigning new attribute values, thus changing the system state. The values that are no longer valid are removed from the state (for details see (Ligeza, 2006)).

Knowledge representation with eXtended Tabular Trees (XTT) incorporates extended attributive table format. Furthermore, similar rules are grouped within separated tables, and the whole system is split into such tables

Table 3. A general scheme of an XTT table

Rule	A_1	A_2	...	A_n	H
1	$\alpha_{11} t_{11}$	$\alpha_{12} t_{12}$...	$\alpha_{1n} t_{1n}$	h_1
2	$\alpha_{21} t_{21}$	$\alpha_{22} t_{22}$...	$\alpha_{2n} t_{2n}$	h_2
\vdots	\vdots	\vdots	\ddots	\vdots	\vdots
m	$\alpha_{m1} t_{m1}$	$\alpha_{m2} t_{m2}$...	$\alpha_{mn} t_{mn}$	h_m

linked by arrows representing the control strategy. Consider a set of m rules incorporating the same attributes A_1, A_2, \dots, A_n : the preconditions can be grouped together and form a regular matrix. After completing with the conclusion part this can be expressed as in Table 3.

In Table 3 the symbol $\alpha_{ij} \in \{=, \neq, \in, \notin\}$ for simple attributes and $\alpha_{ij} \in \{=, \neq, \subseteq, \supseteq, \sim, \not\sim\}$ for the generalized ones. In practical applications, however, the most frequent relations are $=$, \in , and \subseteq , i.e. the current values of attributes are *restricted* to belong to some specific subsets of the domain. If this is the case, the relation symbol can be omitted (i.e. it constitutes the default relation which can be identified by type of the attribute and the value).

The current values of all the attributes are specified within the contents of the knowledge-base (including current sensor readings, measurements, inputs examination, etc.). From logical point of view, it is a formula of the form previously introduced by the formula (1) in Sec. 4.2. Having a table with defined rules, the execution mechanism searches for ones with satisfied preconditions. In short: the satisfaction of preconditions is verified in an algebraic mode, using the dependencies specified in the first row of Table 4 for simple attributes and the first row of Table 5 for the complex ones (see Sec. 7 for more details). The rules having all the preconditions satisfied can be fired. In general, rules can be fired in parallel or sequentially. For the following analysis we assume the classical, sequential model, i.e. the rules are examined in turn in the top-down order and fired if the preconditions are satisfied. The details of the inference with ALSV(FD) needed to implement a complete XTT inference solution are given in the following section.

7. Basic Inference Rules for ALSV(FD)

Since the presented language is an extension of the SAL (Ligeza, 2006), its simple and intuitive semantics is consistent with SAL and clears up some points of it. The summary of the inference rules for atomic formulae with simple attributes (where an atomic formula is the logical consequence of another atomic formula) is presented in Table 4. The table is to be read as follows: if an atomic formula in the leftmost column holds, and a condition

Table 4. Inference for atomic formulae, simple attributes

\models	$A = d_j$	$A \neq d_j$	$A \in V_j$	$A \notin V_j$
$A = d_i$	$d_i = d_j$	$d_i \neq d_j$	$d_i \in V_j$	$d_i \notin V_j$
$A \neq d_i$	–	$d_i = d_j$	$V_j = D \setminus \{d_i\}$	$V_j = \{d_i\}$
$A \in V_i$	$V_i = \{d_j\}$	$d_j \notin V_i$	$V_i \subseteq V_j$	$V_i \cap V_j = \emptyset$
$A \notin V_i$	$D \setminus V_i = \{d_j\}$	$V_i = \{d_j\}$	$V_j = D \setminus V_i$	$V_j \subseteq V_i$

stated in the same row is true, then appropriate atomic formula in the topmost row is also true. In other words, the formula in the topmost row is a logical consequence of the one from the leftmost column provided the condition is fulfilled.

The summary of the inference rules for atomic formulae with generalized attributes (where an atomic formula is the logical consequence of another atomic formula) is presented in Table 5. An example for reading the first row: if $A = V$ (see the leftmost column) and provided that $V \subseteq W$ (the same row, the fourth column) we can conclude that $A \subseteq W$ (the topmost row).

In Table 4 and Table 5 the conditions are *satisfactory* ones. However, it is important to note that in case of the first rows of the tables (the cases of $A = d_i$ and $A = V$, respectively) all the conditions are also *necessary* ones. The rules of Table 4 and 5 can be used for checking if preconditions of a formula hold or verifying subsumption among rules.

For further analysis, e.g. of intersection (overlapping) of rule preconditions one may be interested if two atoms cannot simultaneously be true and if so – under what conditions. For example formula $A \subseteq V \wedge A \subseteq W$ is inconsistent if $V \cap W = \emptyset$. Table 6 specifies the conditions for inconsistency.

The interpretation of the Table 6 is straightforward: if the condition specified at the intersection of some row and column holds, then the atomic formulae labelling this row and column cannot simultaneously hold. Note however, that this is a satisfactory condition only.

Table 6 can be used for analysis of system determinism, i.e. whether satisfaction of a rule precondition implies that the other rules in the same table cannot be fired.

Having the inference on the rule level established, let us now move to the discussion how the inference with the XTT tables (see Table 3) grouping XTT rules (see Sec. 6.2) operating in the same context is performed.

Table 6. Inconsistency conditions for atomic formulae pairs

\neq	$A = W$	$A \subseteq W$	$A \supseteq W$	$A \sim W$
$A = V$	$W \neq V$	$V \not\subseteq W$	$W \not\subseteq V$	$V \cap W \neq \emptyset$
$A \subseteq V$	$W \not\subseteq V$	$V \cap W = \emptyset$	$W \not\subseteq V$	$W \cap V = \emptyset$
$A \supseteq V$	$V \not\subseteq W$	$V \not\subseteq W$	–	–
$A \sim V$	$V \cap W = \emptyset$	$V \cap W = \emptyset$	–	–

8. Inference Strategies for XTT

Any XTT table can have one or more inputs. Let T denote a table. By $I(T)$ we shall denote the number of input links to table T . If there are k such input links, they will be denoted as $1.T, 2.T, \dots, k.T$.

Note that all the links are in fact considered as an AND connection. In order to fire table T all the input tables from which the input links come must be fired to provide the necessary information to fire T .

A similar consideration corresponds to the output. Any table can have one or more output links (from different rules which are placed at the rows of the table), and such an output link can be directed to one or more tables. If there are m such output links we shall denote them as $T.1, T.2, \dots, T.m$.

If an output link $T.j$ goes to n tables $T1, T2, \dots, Tn$, then the links can be denoted as $T.j \rightarrow T1, T.j \rightarrow T2, \dots, T.j \rightarrow Tn$. In fact we can have $\sum_{j=1}^m \dim(j)$, where $\dim(j)$ is the number of addressed tables (here n).

The XTT tables to which no connections point are referred to as *input tables*. The XTT tables with no connections pointing to other tables are referred to as *output tables*. All the other tables (ones having both input and output links) are referred to as *middle tables*.

Now, consider a network of tables connected according to the following principles:

- there is one or more input table,
- there is one or more output table,
- there is zero or more middle tables,
- all the tables are interconnected.

The problem is how to order the inference. The basic principle is that before firing a table, all the immediately preceding tables have already been fired. The structure of the network imposes a partial order with respect to the order of table firing. Below we describe three possible algorithms for the inference control.

Table 5. Inference for atomic formulae, generalized attributes

\models	$A = W$	$A \neq W$	$A \subseteq W$	$A \supseteq W$	$A \sim W$	$A \not\sim W$
$A = V$	$V = W$	$V \neq W$	$V \subseteq W$	$V \supseteq W$	$V \cap W \neq \emptyset$	$V \cap W = \emptyset$
$A \neq V$	–	$V = W$	$W = D$	–	$W = D$	–
$A \subseteq V$	–	$V \subset W$	$V \subseteq W$	–	$W = D$	$V \cap W = \emptyset$
$A \supseteq V$	–	$W \subset V$	$W = D$	$V \supseteq W$	$V \cap W \neq \emptyset$	–
$A \sim V$	–	$V \cap W = \emptyset$	$W = D$	–	$V = W$	–
$A \not\sim V$	–	$V \cap W \neq \emptyset$	$W = D$	–	$W = D$	$V = W$

8.1. Fixed-Order Approach. The simplest algorithm consists of hard-coded order of inference, in such a way that every table is assigned an integer number; all the numbers are different from one another. The tables are fired in order from the lowest number to the highest one.

In order to ensure executability of the inference process, the assignment of such numbers should fulfill the following minimal requirement: for any table T the numbers assigned to tables being predecessors of T must all be lower than the one assigned to T .

After starting the inference process the predefined order of inference is followed. The inference stops after firing the last table. In case a table contains a complete set of rules (w.r.t. possible outputs generated by preceding tables) the inference process should end with producing all the output values defined by all the output tables.

8.2. Token-Transfer Approach. This approach is based on monitoring the partial order of inference defined by the network structure with tokens assigned to tables. A table can be fired only when there is a token at each input. Intuitively, a token at the input is a kind of a flag signalling that the necessary data generated by the preceding table is ready for use.

The tables ready to be fired (with all tokens at the input) are placed in a FIFO queue. The outline of this algorithm is as follows:

- since input tables have 0 inputs, they automatically have all the tokens they need.
- all the input tables are placed in the FIFO queue (in an arbitrary order),
- then the following procedure is repeated; the first table from the queue is fired and removed from the queue, the token is removed from its input and placed at the active output link and passed to all following tables. Simultaneously, if a token is passed to a table, the table is immediately checked if it has tokens at all the inputs; if so, it is put at the end of the queue,
- the process stops when the queue is empty (no further tables to fire).

Note that this model of inference execution covers the case of possible loops in the network. For example, if there is a loop and a table should be fired several times in turn, the token is passed from its output to its input, and it is analyzed if can be fired; if so, it is placed in the queue.

8.3. Goal-Driven Approach. The presented models of inference control can be considered as *blind* procedures since they do not take into consideration the goal of inference. Hence, it may happen that numerous tables are fired without purpose – the results they produce are of no interest. This, in fact, is a deficiency of most of the forward-chaining rule-based inference control strategies.

A *goal-driven approach* works backwards with respect to *selecting* the tables necessary for a specific task, and then fires the tables forwards so as to achieve the goal. The principles of backward search procedure are:

- one or more output tables are identified as the ones that can generate the desired goal values: these are the tables that must be fired,
- these tables are stored on a stack (LIFO queue) in an arbitrary order,
- the following procedure is repeated: list of tables from queue is examined and all the input tables for it are found; they are placed on the stack, while the analyzed table is marked as “needed” and removed from queue,
- only unvisited tables are examined,
- for input tables no analysis is necessary; all the input tables necessary to start the process are identified.

The execution is performed forwards using the token-transfer approach. Tables which are not marked as “needed” on the stack are not fired — they are not necessary to achieve the goal.

Let us now move to practical issues concerning both the design and the implementation of XTT-based systems.

9. XTT Rule Runtime and Design Tools

The XTT approach introduces a new knowledge representation and inference algorithms. This makes the use of existing rule design and implementations impractical and often impossible. The HeKatE project aims at developing not just the conceptual methods but also practical computer tools to support them. Within the project a number of tools to support the design and implementation of the XTT-based systems has been developed. These include:

- visual design tools for rule design (HQEd) and prototyping (HJEd),
- rule runtime environment (HeaRT), and
- rule translation facilities (HaThoR).

All of these tools are build around the XTT knowledge model.

The visual XTT model is represented by means of a human readable, algebraic notation, also called the XTT presentation syntax, or HeKatE Meta Representation (HMR). An example excerpt of HMR is given below:

```
xschm th: [today, hour] ==> [operation].
```

```
xrule th/1:
  [today eq workday,
   hour gt 17]
  ==>
  [operation set not_bizhours].
```

```
xrule th/4:
  [today eq workday,
   hour in [9 to 17]]
  ==>
  [operation set bizhours].
```

The first line defines an XTT table scheme, or header, defining all of the attributes used in the table. Its semantics is as follows: “the XTT table *th* has two conditional attributes: *today* and *hour* and one decision attribute: *operation*”. This information is determined from the conceptual design phase using the ARD method. Then two examples of rules are given. The second rule can be read as: “Rule with ID 1 in the XTT table called *th*: if value of the attribute *today* equals (=) value *workday* and the value of the attribute *hour* belongs to the range (\in) $< 9, 17 >$ then set the value of the attribute *operation* to the value *not_bizhours*”. For a more complete and up-to-date description of HMR see the HeKatE wiki.⁷

The above representation can be directly run by the HeKatE RunTime environment (HeaRT). HMR file is in fact a legal Prolog code that can be interpreted directly (number of custom operators are defined). Therefore HeaRT prototype is implemented in Prolog (Bratko, 2000) and provides the implementation for number of inference

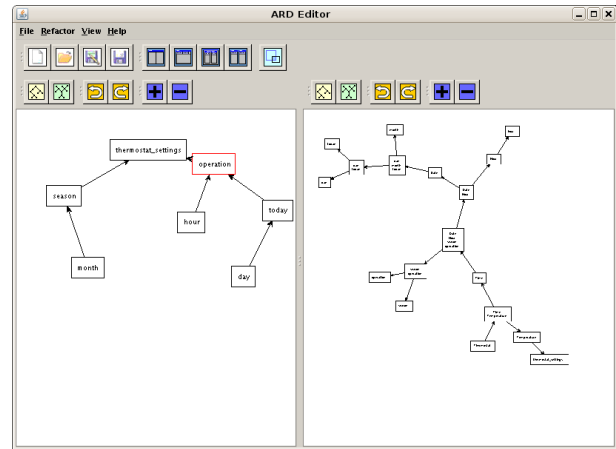

Fig. 5. ARD diagram editing with HJEd

solutions including the three described before. The engine can then be embedded into a complete application, including the interfaces and the presentation layer, using the MVC pattern (see Sec. 3). In this case HeaRT provides the logical Model. The control logic is built in a declarative way, using the structured XTT representation. The engine provides a flexible communication mechanism using callbacks that can be run on the attribute values updates. The callbacks can be implemented in any language, using a Prolog interface, currently Java, Python and PHP callback interfaces are available.⁸

In order to design the XTT model visual editors introduced in Sec. 3 are used. In the rule prototyping with ARD phase currently two tools are available: VARDA and HJEd. They support the visual design of the ARD diagrams, modelling functional dependencies between XTT rule attributes. VARDA is a proof of concept prototype tool written in Prolog. HJEd is a portable visual editor implemented in Java. An example session with HJEd is presented in Fig. 5. The output from this phase allows for generating XTT table schemes.

One of the main features of the XTT method is the compact visual representation. From the designer point of view it needs to be supported by a CASE tool in order to be effective. The *HQed* (Kaczor, 2008; Kaczor and Nalepa, 2008) tool (Fig. 6) uses the rule prototypes generated in the conceptual design, and supports the actual visual process of the logical design of XTT tables. It is a cross-platform tool written in C++ and the Qt library.

One of the most important editor features is the support for XTT; it concerns *rulebase quality assurance* and refers to several specific issues: condition specification constraints, structured rulebase syntax, gradual model refinement, with partial simulation logical rule model quality. The first issue is tackled by providing a number of

⁷<https://ai.ia.agh.edu.pl/wiki/hekate:hmr>

⁸See <https://ai.ia.agh.edu.pl/wiki/hekate:heart> for a more up-to-date description of HeaRT.

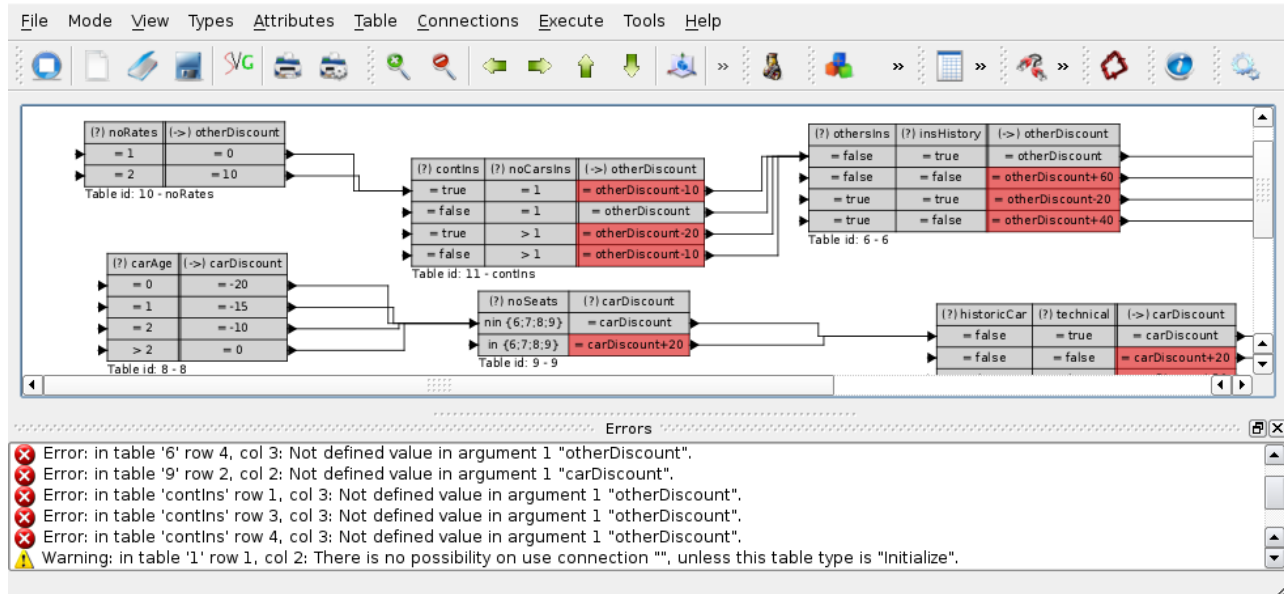

Fig. 6. HQEd editing session, the XTT rulebase structure with anomalies detected

editing features enforcing strict user data verification. Every attribute value entered into XTT cells (corresponding to the ALSV(FD) formulae) is checked against the attribute domain. On the other hand the user is hinted during the editing process, with feasible attribute values.

The rulebase syntax may be checked against anomalies, e.g. incomplete rule specification, malformed inference specification, including missing table links. The editor allows for gradual rules refinement, with an online checking of attribute domains, as well as simple table properties, such as inference related dead rules. In case of simple tables it is possible to emulate and visualize the inference process.

However, the main quality feature being developed is a plugin framework, allowing for integrating Prolog-based components for rule analysis (being part of the inference engine) to check formal properties of the XTT rule base, such as completeness, redundancy, or determinism (Ligeza and Nalepa, 2005). Here analysis is performed on the logical level, where the rows of the XTT tables are interpreted and analyzed as ALSV(FD) formulae.

Another important group of HeKatE tools are knowledge translators (HaThoR). They use HMR *serialization* to an XML-based format known as the HML (*HeKatE Markup Language*). This format is used by the editing tools to store the model together with some technical information such as diagram location in the editor, etc. The HML translators are implemented with the use of XSLT (Clark, 1999), which provides an XML-based syntax for defining XML translators. The HaThoR framework aims at allowing exchange between the HeKatE

knowledge representation and other important rule formats. These are mainly being developed by the Semantic Web initiative⁹ and include: RIF¹⁰ that provides a generic rule interchange format, and SWRL (*A Semantic Web Rule Language*) (Horrocks, Patel-Schneider, Boley, Tabet, Grosz and Dean, 2004) that builds on ontologies.

Considering the use of decision rules in the web applications, it is worth mentioning the EU FP6 REVERSE Project (see <http://reverse.net>). The REVERSE I1 group proposed number of rule-related languages, including URML (Lukichev and Wagner, 2005) for UML-based rule authoring, and – more importantly – R2ML (Wagner, A.Giurca and Lukichev, 2005; Wagner, Giurca and Lukichev, 2006) for a flexible rule interchange with OCL (Object Management Group, 2006), RuleML (Boley, Tabet and Wagner, 2001) and SWRL (Horrocks *et al.*, 2004). The project provides number of XML-based rule translators (see <http://oxygen.informatik.tu-cottbus.de/reverse-i1/?q=node/15>). Considering the Semantic Web applications, they also support Jena Rules (Reynolds, 2005) (Jena is a RDF framework for the Semantic Web <http://jena.sourceforge.net>).

All of the tools are released as *free software*¹¹ under the terms of the GNU GPL licence from the project website, see <http://hekat.eia.agh.edu.pl>.

⁹<http://www.w3.org/2001/sw>

¹⁰http://www.w3.org/2005/rules/wiki/RIF_Working_Group

¹¹<http://www.gnu.org/philosophy/free-sw.html>

10. Related Tools

The primary idea behind the XTT as the knowledge representation, and HeKatE as the design methodology, was to overcome selected important limitations of well-established approaches, see Sec. 3.1. Considering that fact, it is important to briefly evaluate the results achieved. Here, the focus is on two most important solutions, that have become *de facto* standards and are openly available, see Sec. 2. The first is CLIPS and its new Java-based incarnation – Jess. The other one is Drools, which inherits some of the important CLIPS features, such as Rete-based inference, while providing a number of high-level integration features on the Java Enterprise Edition platform.

Previously, in Sec. 3.1 three main problems areas where identified, that is: 1) knowledge representation, 2) transparent structure and efficient inference in the rule-base, 3) well founded systematic and complete design process.

As of the first issue, XTT provides an expressive, formally defined language to describe rules. The language allows for formally described inference, property analysis, and code generation. Additional callbacks in rule decision provide means to invoke external functions or methods in any language. This feature is superior to those found in both CLIPS/Jess and Drools. On the other hand, the main limitation of the HeKatE approach is the state-base description of the system, where the state is understood as the set of attribute values. This solution is well fit to a number of well defined control or decision process. However, it might prove insufficient in more general applications. In that case CLIPS/Jess offers several other programming paradigms, including an object-oriented one. Drools is integrated with the Java stack, opening means to program almost anything. One should keep in mind, that such heterogeneous multi-paradigm programs cannot be considered plain “rule-base systems” anymore. It should also be emphasized that in a general case, a formal analysis of such systems is hardly possible.

The implicit rule base structure is another important feature of XTT. Rules are grouped into decision tables during the design, and the inference control is designed during the conceptual design, and later on refined during the logical design. Therefore the XTT representation is highly optimized towards rulebase structurization. This is different from all the Rete-based solutions, including all three, that is CLIPS, Jess, and Drools. This feature makes the visual design much more transparent and scalable. It also greatly improves the inference process.

It is worth noting, that in fact all the Rete-based solutions seek some kind of structurization. In the case of CLIPS it is possible to modularize the rulebase (see chapter 9 in (Giarratano and Riley, 2005)). It is possible to group rules in modules operating in given contexts, and then provide a context switching logic. Such a modular-

ized structure can correspond to phases of the decision process. Another solution is the rule set hierarchization. Drools 5 offers Drools Flow that allows to define rule set and simple control structure determining their execution. In fact this is similar to the XTT-based solution. However, it is a weaker mechanism that does not correspond to table-based solution. In XTT rules having the same attributes are grouped by design. This opens up possibilities to inference optimization and strong formal analysis on the table level. A group (subtree) of linked XTT tables can also be defined to work in a given context.

The last issue concerning a complete design process seems to be in practice the most important one. Both CLIPS and Jess are classic expert system shells, providing rule languages, and runtimes. They are not directly connected to any design methodology. The rule language does not have any visual representation, so no complete visual editors are available. In fact, the implementation process for these systems can be supported by a number of external environments, with Eclipse¹² being the best example. Jess 7 provides JessDE, and Eclipse plugins-based environment. However, it is worth emphasizing, that these tools do not visualize the knowledge contained in the rule base. In fact, they simplify syntax checking, runtime debugging (including the Rete network view) and rule management.

Drools 5 is decomposed into four main parts: Guvnor, Expert, Flow, Fusion. It offers several support tools, namely the Eclipse-based environment, similar but more robust that one Jess provides. One of the “design support” feature, is the ability to read Excel files containing simple decision tables, with basic control structure. While this is a valuable feature it does not provide any on-line syntax checking.

In both cases it is crucial to emphasize, that there is a fundamental difference between a graphical user interface like the one provided by generic Eclipse-based solutions, and *visual design support and specification* provided by languages such as XTT for rules, in software engineering by UML, or by Petri Nets for parallel systems.

11. Conclusions

The primary area of interest of this paper is the design of rule-based intelligent control and decision support systems. In the paper a review of the state of the art in rule-based systems is given. Based on it, some practical issues in the design of rule-based controllers are discussed. Major drawbacks in the existing solutions are identified, including limitations in the formal language definition, internal knowledge structure, and systematic design procedure.

This analysis provides guidelines for the HeKatE approach. It aims at solving these limitations by the in-

¹²<http://www.eclipse.org>

roduction of a custom formalized rule language called XTT (in fact, the version considered in this paper is called XTT²). The formalization is based on the ALSV(FD) logic. In the described approach a systematic design process for rule-based systems is considered. It is practically supported by a number of tools presented in the paper.

The original contribution of the presented approach covers the following issues:

- clear definition of formal logical language with an intuitive interpretation for knowledge representation,
- modular structure of the rule base and oriented towards modular development methodology,
- goal-directed inference and flexible inference modes,
- formal verification of XTT knowledge modules,
- consistent top-down design methodology supported by software tools.

Some future extensions of the presented formalism are also considered, including fuzzy rules. However, these are out of scope of this paper. For more details see (Ligeza and Nalepa, 2008).

The up-to-date results of the project, as well all the relevant papers are available at the project website see <http://hekat.eia.agh.edu.pl>. A repository of tools available for download is also open for the community.

12. Acknowledgements

The paper is supported by the *HeKatE* Project funded from 2007–2009 resources for science as a research project.

The Authors wish to thank the anonymous reviewers for their valuable comments and remarks that greatly helped in improving the final version of the paper.

Special thanks are due Dr. Marcin Szyrka, Dr. Sławomir Nowaczyk, Claudia Obermaier, and Weronika T. Furmańska for reading the preliminary versions of the papers and providing us with valuable comments, remarks and criticism that helped us to improve the paper, as well as gain a broader perspective on our work.

We would like to kindly acknowledge an important contribution from our master students Krzysztof Kaczor, Michał Gawędzki, Szymon Bobek, and Szymon Książek implementing tools mentioned in this paper.

References

- Ben-Ari, M. (2001). *Mathematical Logic for Computer Science*, Springer-Verlag, London.
- Boley, H., Tabet, S. and Wagner, G. (2001). Design rationale of ruleml: A markup language for semantic web rules, *SWWS'01*, Stanford.
- Bratko, I. (2000). *Prolog Programming for Artificial Intelligence*, 3rd edn, Addison Wesley.
- Browne, P. (2009). *JBoss Drools Business Rules*, Packt Publishing.
- Brownston, L., Farrell, R., Kant, E. and Martin, N. (1985). *Programming Expert Systems in OPS5*, Addison-Wesley.
- Burbeck, S. (1992). Applications programming in smalltalk-80(tm): How to use model-view-controller (mvc), *Technical report*, Department of Computer Science, University of Illinois, Urbana-Champaign.
- Cheng, A. M. K. (2002). *Real-Time Systems. Scheduling, Analysis and Verification*, John Wiley & Sons, Inc., Hoboken, New Jersey.
- Clark, J. (1999). Xsl transformations (xslt) version 1.0 w3c recommendation 16 november 1999, *Technical report*, World Wide Web Consortium (W3C).
- Connolly, T., Begg, C. and Strechan, A. (1999). *Database Systems, A Practical Approach to Design, Implementation, and Management*, 2nd edn, Addison-Wesley.
- et. al, F. C. (2000). Validation and verification of knowledge-based systems: report on eurovav99, *The Knowledge Engineering Review* **15**(2): 187–196.
- Fagan, L., Kunz, J. and Feigenbaum, E. (1979). Representation of dynamic clinical knowledge: Measurement interpretation in the intensive care unit, *Proceedings of the Sixth Int. Joint Conferences of Artificial Intelligence*, Morgan Kaufmann, Los Altos, CA, pp. 260–262.
- Fagan, L. M. (1980). *VM: Representing Time Dependent Relations in a Medical Setting*, PhD thesis, Dept. of Computer Science, Stanford University.
- Forgy, C. (1982). Rete: A fast algorithm for the many patterns/many objects match problem, *Artif. Intell.* **19**(1): 17–37.
- Friedman-Hill, E. (2003). *Jess in Action, Rule Based Systems in Java*, Manning.
- Gamma, E., Helm, R., Johnson, R. and Vlissides, J. (1995). *Design Patterns*, 1st edn, Addison-Wesley Pub Co.
- Genesereth, M. R. and Nilsson, N. J. (1987). *Logical Foundations for Artificial Intelligence*, Morgan Kaufmann Publishers, Inc., Los Altos, California.
- Giarratano, J. C. and Riley, G. D. (2005). *Expert Systems*, Thomson.
- Giurca, A., Gasevic, D. and Taveter, K. (Eds) (2009). *Handbook of Research on Emerging Rule-Based Languages and Technologies: Open Solutions and Approaches*, Information Science Reference.
- Horrocks, I., Patel-Schneider, P. F., Boley, H., Tabet, S., Grosz, B. and Dean, M. (2004). Swrl: A semantic web rule language combining owl and ruleml, w3c member submission 21 may 2004, *Technical report*, W3C.
- Jackson, P. (1999). *Introduction to Expert Systems*, 3rd edn, Addison-Wesley. ISBN 0-201-87686-8.
- Kaczor, K. (2008). *Design and implementation of a unified rule base editor*, Master's thesis, AGH University of Science and Technology. Supervisor: G. J. Nalepa.

- Kaczor, K. and Nalepa, G. J. (2008). Design and implementation of hqed, the visual editor for the xtt+ rule design method, *Technical Report CSLTR 02/2008*, AGH University of Science and Technology.
- Klösigen, W. and Żytkow, J. M. (Eds) (2002). *Handbook of Data Mining and Knowledge Discovery*, Oxford University Press, New York.
- Laffey, T. and *et al.* (1988). Real-time knowledge-based systems, *AI Magazine Spring*: 27–45.
- Liebowitz, J. (Ed.) (1998). *The Handbook of Applied Expert Systems*, CRC Press, Boca Raton.
- Ligeza, A. (1986). An expert systems approach to analysis and control in certain complex systems, *Preprints of the 4-th IFAC/IFIP Symposium on Software for Computer Control SOCOCO'86*, Graz, pp. 147–152.
- Ligeza, A. (1988). Expert systems approach to decision support, *European Journal of Operational Research* **37**(1): 100–110.
- Ligeza, A. (1993). Logical foundations for knowledge-based control systems – knowledge representation, reasoning and theoretical properties, *Scientific Bulletins of AGH Automatics* **63**(1529): 144 pp., Kraków.
- Ligeza, A. (1996). Logical support for design of rule-based systems. reliability and quality issues, in M. Rousset (Ed.), *ECAI-96 Workshop on Validation, Verification and Refinement of Knowledge-based Systems*, Vol. W2, ECAI'96, Budapest, pp. 28–34.
- Ligeza, A. (1998). Towards logical analysis of tabular rule-based systems, *Proceedings of the Ninth European International Workshop on Database and Expert Systems Applications, Vienna, Austria* pp. 30–35.
- Ligeza, A. (1999). *Validation and verification of knowledge based systems : theory, tools and practice*, Kluwer Academic Publishers/Kluwer Academic Publishers, Boston, Dordrecht, London, chapter Intelligent data and knowledge analysis and verification; towards a taxonomy of specific problems, pp. 313–325.
- Ligeza, A. (2001). Toward logical analysis of tabular rule-based systems, *International Journal of Intelligent Systems* **16**(3): 333–360. Special issue on Verification and Validation Issues in Databases, Knowledge-Based Systems, and Ontologies.
- Ligeza, A. (2005). *Logical Foundations for Rule-Based Systems*, Uczelniane Wydawnictwa Naukowo-Dydaktyczne AGH w Krakowie, Kraków.
- Ligeza, A. (2006). *Logical Foundations for Rule-Based Systems*, Springer-Verlag, Berlin, Heidelberg.
- Ligeza, A. and Nalepa, G. J. (2005). Visual design and on-line verification of tabular rule-based systems with xtt, in K. P. Jantke, K.-P. Fähnrich and W. S. Wittig (Eds), *Marktplatz Internet: Von e-Learning bis e-Payment : 13. Leipziger Informatik-Tage, LIT 2005*, Lecture Notes in Informatics (LNI), Gesellschaft für Informatik, Bonn, pp. 303–312.
- Ligeza, A. and Nalepa, G. J. (2007). Knowledge representation with granular attributive logic for XTT-based expert systems, in D. C. Wilson, G. C. J. Sutcliffe and FLAIRS (Eds), *FLAIRS-20 : Proceedings of the 20th International Florida Artificial Intelligence Research Society Conference : Key West, Florida, May 7-9, 2007*, Florida Artificial Intelligence Research Society, AAAI Press, Menlo Park, California, pp. 530–535.
- Ligeza, A. and Nalepa, G. J. (2008). Granular logic with variables for implementation of extended tabular trees, in D. C. Wilson and H. C. Lane (Eds), *FLAIRS-21: Proceedings of the twenty-first international Florida Artificial Intelligence Research Society conference: 15–17 may 2008, Coconut Grove, Florida, USA*, AAAI Press, Menlo Park, California, pp. 341–346.
- Ligeza, A., Wojnicki, I. and Nalepa, G. J. (2001). Tab-trees: a case tool for design of extended tabular systems, in H. M. *et al.* (Ed.), *Database and Expert Systems Applications*, Vol. 2113 of *Lecture Notes in Computer Sciences*, Springer-Verlag, Berlin, pp. 422–431.
- Logical Support for Design of Rule-Based Systems. Reliability and Quality Issues* (1996). Budapest. Also: LAAS Report, No.: 96170.
- Lukichev, S. and Wagner, G. (2005). Visual rules modeling, *Sixth International Andrei Ershov Memorial Conference PERSPECTIVES OF SYSTEM INFORMATICS, Novosibirsk, Russia, June 2006*, LNCS, Springer.
- Object Management Group (2006). Object constraint language version 2.0, *Technical report*, OMG.
- Morgan, T. (2002). *Business Rules and Information Systems. Aligning IT with Business Goals*, Addison Wesley, Boston, MA.
- Nalepa, G. J. (2004). *Meta-Level Approach to Integrated Process of Design and Implementation of Rule-Based Systems*, PhD thesis, AGH University of Science and Technology, AGH Institute of Automatics, Cracow, Poland.
- Nalepa, G. J. and Ligeza, A. (2005a). A graphical tabular model for rule-based logic programming and verification, *Systems Science* **31**(2): 89–95.
- Nalepa, G. J. and Ligeza, A. (2005b). *Software engineering : evolution and emerging technologies*, Vol. 130 of *Frontiers in Artificial Intelligence and Applications*, IOS Press, Amsterdam, chapter Conceptual modelling and automated implementation of rule-based systems, pp. 330–340.
- Nalepa, G. J. and Ligeza, A. (2005c). A visual edition tool for design and verification of knowledge in rule-based systems, *Systems Science* **31**(3): 103–109.
- Nalepa, G. J. and Ligeza, A. (2006). Prolog-based analysis of tabular rule-based systems with the "xtt" approach, in G. C. J. Sutcliffe and R. G. Goebel (Eds), *FLAIRS 2006 : proceedings of the nineteenth international Florida Artificial Intelligence Research Society conference : [Melbourne Beach, Florida, May 11–13, 2006]*, Florida Artificial Intelligence Research Society, AAAI Press, FLAIRS. - Menlo Park, pp. 426–431.
- Nalepa, G. J. and Ligeza, A. (2008). Xtt+ rule design using the alsv(fd), in A. Giurca, A. Analyti and G. Wagner (Eds), *ECAI 2008: 18th European Conference on Artificial Intelligence: 2nd East European Workshop on Rule-based*

- applications, *RuleApps2008: Patras, 22 July 2008*, University of Patras, Patras, pp. 11–15.
- Pawlak, Z. (1991). *Rough Sets. Theoretical Aspects of Reasoning about Data*, Kluwer Academic Publishers, Dordrecht/Boston/London.
- Quinlan, J. R. (1986). Simplifying decision trees.
- Reynolds, D. (2005). Jena Rules experiences and implications for rule use cases, *W3C Workshop on Rule Languages for Interoperability*. <http://www.w3.org/2004/12/rules-ws/slides/davereynolds.pdf>.
- Ross, R. G. (2003). *Principles of the Business Rule Approach*, 1 edn, Addison-Wesley Professional.
- Torsun, I. S. (1995). *Foundations of Intelligent Knowledge-Based Systems*, Academic Press, London, San Diego, New York, Boston, Sydney, Tokyo, Toronto.
- Tzafestas, S. and Ligęza, A. (1988). Expert control through decision making, *Foundations of Control Engineering* **13**(1): 43–51.
- Tzafestas, S. and Ligęza, A. (1989). Expert control through decision making, *Journal of Intelligent and Robotic Systems* **1**(4): 407–425.
- van Harmelen, F. (1996). Applying rule-based anomalies to kads inference structures, *ECAI'96 Workshop on Validation, Verification and Refinement of Knowledge-Based Systems* pp. 41–46.
- van Harmelen, F., Lifschitz, V. and Porter, B. (Eds) (2007). *Handbook of Knowledge Representation*, Elsevier Science.
- von Halle, B. (2001). *Business Rules Applied: Building Better Systems Using the Business Rules Approach*, Wiley.
- Wagner, G., A.Giurca and Lukichev, S. (2005). R2ml: A general approach for marking up rules, in F. Bry, F. Fages, M. Marchiori and H. Ohlbach (Eds), *Principles and Practices of Semantic Web Reasoning, Dagstuhl Seminar Proceedings 05371*.
- Wagner, G., Giurca, A. and Lukichev, S. (2006). A usable interchange format for rich syntax rules integrating ocl, ruleml and swrl, *Proceedings of Reasoning on the Web*, Edinburgh, Scotland. <http://www.aifb.uni-karlsruhe.de/WBS/phi/RoW06/procs/wagner.pdf>.

Received: 30 January 2009

Revised: 30 April 2009

Re-revised: 30 July 2009