

# NASA Contractor Report 178173

THE HELMHOLTZ RESONANCE BEHAVIOR  
OF SINGLE AND MULTIPLE ROOMS

(NASA-CR-178173) THE HELMHOLTZ RESONANCE  
BEHAVIOR OF SINGLE AND MULTIPLE ROOMS  
(Bionetics Corp.) 27 p CSDL 20A

N87-10749

G3/71 44282  
Unclas

Harvey H. Hubbard and Kevin P. Shepherd

THE BIONETICS CORPORATION  
Hampton, Virginia

Contract NAS1-16978  
September 1986

The NASA logo, consisting of the word "NASA" in a bold, sans-serif font with a stylized "N" and "A".

National Aeronautics and  
Space Administration

**Langley Research Center**  
Hampton, Virginia 23665

TABLE OF CONTENTS

INTRODUCTION . . . . . 1

HELMHOLTZ RESONATOR PERFORMANCE . . . . . 1

DESCRIPTION OF TEST EQUIPMENT . . . . . 2

    Room Configurations . . . . . 2

    Instrumentation . . . . . 2

EXCITATION OF HELMHOLTZ RESONANCES IN SINGLE ROOMS . . . . . 3

    Example Calculations . . . . . 3

    Results of Model Experiments . . . . . 3

    Results of Room Experiments . . . . . 3

        Low Frequency Responses . . . . . 4

        Sound Pressure Level Gradients . . . . . 4

COUPLING OF HELMHOLTZ RESONANCES FOR MULTIPLE ROOMS . . . . . 5

MECHANICAL COUPLING BETWEEN ADJACENT ROOMS . . . . . 5

COMPARISONS OF MEASURED AND CALCULATED HELMHOLTZ  
    RESONANCE FREQUENCIES . . . . . 6

CONCLUDING REMARKS . . . . . 7

REFERENCES . . . . . 7

FIGURES . . . . . 9

## INTRODUCTION

In situations where people are exposed to low frequency noise, it has been reported, on occasion, that the exposures inside of house structures are more objectionable than those outside. There are various possible explanations for this observation, including differences in activity patterns and expectations. A further possibility is that the structure of the house may affect the spatial distribution of the noise field in such a way as to locally enhance the noise levels. One possible mechanism for noise level enhancement is the excitation of Helmholtz resonances in one or more of the rooms. To date there is very little information available in the literature relating to the nature and scope of such resonances in an exposed house.

This paper presents the results of some exploratory measurements of the noise fields inside rooms which are excited to resonance either acoustically or mechanically. The data illustrate the nature and extent of the sound pressure level enhancements in single rooms and also how multiple rooms may resonate by means of either acoustic or mechanical coupling.

## HELMHOLTZ RESONATOR PERFORMANCE

A simple Helmholtz resonator consists of a rigid enclosure for a volume of gas (air) communicating with the external medium through a small opening, the shape and size of which are significant. Assuming that the dimensions of the resonator are small in comparison with the wavelength of the sound, the motion of the resonator system is analogous to that of a mechanical system having lumped elements of mass, stiffness and damping. The gas in the opening is considered to move as a unit and provides the mass element of the system. The pressure of the gas within the cavity of the resonator changes as it is alternately compressed and expanded by the motion of the gas through the opening, and provides the stiffness element. At the opening there is radiation of sound which leads to some dissipation of acoustic energy, thus providing a damping mechanism. Further damping occurs due to viscous losses associated with the motion of gas in the opening.

It may be shown (see refs. 1 & 2) that the frequency of undamped free oscillation is given by:

$$f_H = \frac{c}{2\pi} \left[ \frac{A}{V(t+\delta)} \right]^{1/2}$$

where  $c$  is the speed of sound,  $A$  is the cross sectional area of the opening,  $t$  is the length of the opening,  $V$  is the volume of the enclosure and  $\delta$  is an end correction term sometimes written as

$$\delta = 0.8A^{1/2}$$

This latter expression is precise for small resonators for which the geometry is well defined, but may be in error for rooms in which the geometry of the door opening is complex (see inset sketch of figure 1). The above expression for resonant frequency indicates that for a constant enclosed volume, the resonant frequency increases with increased area of the opening.

## DESCRIPTION OF TEST EQUIPMENT

### Room Configurations

Two sets of rooms, as sketched in figure 1, were used to obtain the results of this study. Rooms A, B, C and D are laboratory spaces, opening into a larger room. Room A which is a reverberation room, has relatively massive reinforced concrete surfaces with interior nominal dimensions of 2.9 m X 4.1 m X 3.5 m and a volume of about 41.6 m<sup>3</sup>. Its common wall with room B includes a 20 ft.<sup>2</sup> test area of lighter construction. Room B also has relatively solid surfaces except for the common curtain wall consisting of staggered metal studs with gypsum board sheathing, which it shares with room C. It has nominal dimensions of 3.8 m X 3.1 m X 3.7 m and a volume of about 43.5 m<sup>3</sup>. Room C has two lightly constructed curtain walls plus an acoustical drop ceiling. Its nominal dimensions are 3.8 m X 3.1 m X 2.7 m. It has a volume of about 43.5 m<sup>3</sup> including the 1-meter airspace above the drop ceiling. Room D has nominal dimensions of 3.8 m X 2.4 m X 2.7 m and a total volume of about 33.7 m<sup>3</sup>. It shares a common curtain wall with room C and has a similar drop ceiling configuration.

Rooms E and F are rest rooms having relatively massive masonry walls with tile, plaster and masonry interior surfaces. They are contiguous and open into a four foot wide hallway. Room E has dimensions of 2.9 m X 1.7 m X 2.4 m and a volume of about 11.8 m<sup>3</sup>. Room F has dimensions of 1.9 m X 1.6 m X 2.4 m and a volume of about 7.3 m<sup>3</sup>.

Door openings to all except room A were nominal .913 m X 2.1 m (36 in. X 83 in.) with door jamb details as shown in the inset sketch of figure 1. Room A has a 1.1 m X 2.1 m door opening with otherwise similar geometry.

### Instrumentation

A conventional signal generator and amplifier were used to drive a large loudspeaker when broadband or pure tone excitation was required (see figure 2). One microphone was located outside the room as a reference and a second movable microphone was placed inside the room. An FFT Analyzer was used to compare the two microphone signals in real time for measuring sound pressure level, spectra and phase differences. For mechanical excitation studies, a force gage and a small conventional shaker were attached to one wall of room C.

In some situations it was found that ambient noise inside the building was sufficient to excite the rooms in their Helmholtz modes.

#### EXCITATION OF HELMHOLTZ RESONANCES IN SINGLE ROOMS

In order to develop appropriate measurement and analyses procedures, initial tests were performed using a small rigid plywood box resonator. Subsequently, measurements and observations were made in each of the test rooms in attempts to define their Helmholtz resonance responses. The resonant conditions for the test rooms were difficult to determine from subjective observations because resonant frequencies were at the low end of the audible range where the human ear is relatively insensitive. Signal strength was also limited in some cases to existing ambient levels and in others by the loudspeaker output which is relatively weak at the very low frequencies. Reliance was therefore placed on the measured sound pressure levels and phase relationships to define conditions of resonance in the data of figures 3-13.

#### Example Calculations

By means of the relationship previously introduced (from ref. 1), example calculations were made for the model and for the rooms with doors fully open and partially open, assuming an ambient temperature of 21°C, for which  $c = 344$  m/sec. For the model which has dimensions of .305 m (1 ft.) X .305 m X .610 m (2 ft.) and which is made of 1.78 cm plywood with a 17.8 cm diameter hole, the calculated resonant frequency is 95.7 Hz. For the room models, assuming a neck length  $t$ , of 7 cm the calculated values varied from 5.5 Hz to 25.4 Hz as shown in table 1.

#### Results of Experiments with Model

In order to evaluate measurement techniques the equipment shown schematically in figure 2 was used in connection with tests of the model resonator in the sketch of figure 3. The model was excited by a broad band signal from a loudspeaker and the differences in sound pressure level and phase at points inside and outside, respectively, were determined. The peak in the sound pressure level data of the upper plot of figure 3 shows amplification at a frequency near 95 Hz which is close to the predicted resonance value. The lower plot shows a rapid change in phase difference between the two microphone signals, a change of 180° occurring over a frequency range which encompasses the resonance frequency.

#### Results of Room Measurements

Low frequency response data were obtained for rooms A, B, C, and D for ambient noise excitation and for room E excited by both broad band and discrete frequency noise from a loudspeaker. Fre-

quency response data, phase relationships and some sound pressure level gradients were measured.

Low Frequency Responses. Figures 4 and 5 show frequency response data for rooms A, B, C, and D due to ambient noise excitation. Although the noise levels are generally low, there is evidence of a resonance in each case in the frequency range 6-10 Hz. The sound pressure level differences between inside and outside are lower for the rooms than for the model of figure 3. This suggests that losses due to damping are much greater for the rooms, due possibly to wall and ceiling flexibility (see ref. 3). Since other data of the paper show that the outside sound pressure levels are a strong function of the locations of the measurement points, it will not be possible to make definite conclusions regarding amplification factors.

There is also evidence of phase changes near resonance. These phase changes are not so rapid or well defined as they are for the small model, due probably to the broader frequency responses and lower amplification factors of the rooms.

Figure 6 presents frequency response data for room E excited by broad band noise from a loudspeaker. Results are given for two different door opening configurations. For the door fully open, there is a resonance near 20 Hz. When the door is part open the resonant frequency moves to a lower value and the phase change is more abrupt.

Sound Pressure Level Gradients. - For conditions where room E was observed to resonate in the Helmholtz mode, measurements were made to define the sound pressure level gradients both inside and outside the room for door open and closed conditions. The results obtained by pure tone excitation with a loudspeaker are shown in figures 7 and 8.

Figure 7 shows a series of measurements made at floor level from the loudspeaker through the door opening and inside to the back of the room. For the door fully open condition, the levels are seen to reduce with distance to a minimum value outside the room and then to build up as distance is increased into the room. The levels inside the room at distances in excess of 6 m in figure 7, are seen to exceed those measured close to the loudspeaker. When the same measurement sequence is repeated for the door closed condition, the levels outside the room are noted to be higher than those inside.

The data of figure 8 show the results of sound pressure level measurements inside room E in three different directions, during resonance, with the door fully open. The largest gradient occurs near the open door. In much of the room interior there are only small gradients. This is in marked contrast to the large gradients observed in the excitation of normal acoustic modes in a room (see ref. 4). Note that these latter modes are excited at frequencies

for which the acoustic wave lengths are comparable to or less than the room dimensions whereas at Helmholtz resonant frequencies the wave lengths are characteristically large compared to the room dimensions.

#### COUPLING OF HELMHOLTZ RESONANCES FOR MULTIPLE ROOMS

Rooms E and F are located side by side and they open into a common hallway. Results from tests of this latter configuration are of interest for any situation where there may be significant interactions between rooms excited by a common noise source.

The data of figure 9 illustrate the sound pressure level gradients in the connecting hallway for various room door opening configurations for excitation by a loudspeaker at a discrete frequency of 21 Hz. With doors for room E and F both closed, there is a general decrease in sound pressure level with distance until the end of the hallway is approached. When doors are opened in various combinations the hallway levels are affected, in some cases substantially. These changes in level resulting from door openings are similar to those which might be expected for the case of side branch resonators in a duct. Note that both rooms exhibit resonance behavior at 21 Hz.

As the sound pressure level gradients change in the hallway outside of rooms E and F due to door openings and closings, so also do the levels inside the rooms. The sketches of figure 10 illustrate the manner in which these changes occur for the various test conditions. Note that the levels indicated are the maximum values measured for that particular configuration. It can be seen that changes in the hallway levels of figure 9 correlate generally with the occurrences of room resonances of figure 10.

It is significant that variations in the sound pressure level at locations inside the rooms and also outside the rooms in the hallway are as high as 20 dB for a steady input noise excitation. This implies that a person might experience this order of magnitude change in ambient levels at a particular location, depending on the door opening configuration, or as a function of location for a particular door arrangement. During the tests it was noted that the highest levels of figure 10 could be readily observed subjectively whereas the lowest levels were not observable.

#### MECHANICAL COUPLING BETWEEN ADJACENT ROOMS

There is a possibility that mechanical coupling between rooms might also excite acoustic resonances. In order to evaluate this phenomenon for these test rooms, a mechanical shaker was used to vibrate the common wall between rooms B and C. The wall was excited over a range of discrete frequencies, at a constant force

to the shaker, and acoustic measurements were made in both rooms C and D.

The data of figure 11 show the acoustic responses of room C, for three different door opening configurations, due to mechanical excitation of one of its walls. It can be seen that the data points group together closely for the three test conditions. Two resonant peaks are noted. The lower peak is the Helmholtz mode of the room whereas the higher frequency peak is the first structural mode of the wall.

Surveys inside room C were made in three directions to evaluate the sound pressure level gradients at frequencies corresponding to the two response peaks of figure 11. These gradient data are presented in figures 12 (a) and (b) respectively. The measured gradients are noted to be similar and to be small in both cases. This suggests that in the case of the wall resonance, where the room dimensions are much smaller than the wave length, the room response is very similar to that of the Helmholtz mode.

Sound pressure level measurements were also made in room D and are shown in figure 13 for comparison with similar data for room C. The Helmholtz mode and the wall resonance mode are both excited by the sound field in room C. Thus in situations where methods of construction and dimensions are similar, acoustic disturbances can probably be transmitted from room to room, by mechanical or acoustical coupling or some combination of the two.

#### COMPARISONS OF MEASURED AND CALCULATED HELMHOLTZ RESONANCE FREQUENCIES

A summary of measured and calculated Helmholtz resonance frequencies are presented in Table I for each room and for the small model resonator. Agreement between measured and predicted values is very good for the model and for the door-open configurations of rooms E and F. It is important to note that the prediction procedure assumes that the resonator cavity walls are rigid, a condition that is essentially met for the above configurations. The other rooms (A to D) have door open resonance frequencies generally lower than the predicted values. These latter rooms each have at least one relatively flexible wall, a condition which results in reduced stiffness and a lower resonant frequency.

As the open area is reduced by partly closing the door, the predicted value of the resonant frequency is reduced, as can be seen from the results of Table I. The measurements also indicate the same general trend, but the measured frequency reductions are much less than the predicted reductions. A possible explanation for this disparity is that a hinged door is not a rigid surface, and thus the effective reduction in the area of the opening is much less than anticipated. An implication of these data is that



observed Helmholtz frequencies in rooms will probably not be affected significantly by the amount of door opening.

### CONCLUSIONS

Measurements of Helmholtz resonances in single and multiple rooms indicated the following:

- o Helmholtz resonances can be excited by acoustic excitation due to a loudspeaker or ambient noise, due to mechanical vibration by a shaker and due to acousto-mechanical interactions in a room/hallway complex.
- o During Helmholtz resonance of a room the inside pressures were everywhere in phase and tended to be uniform in level.
- o Sound pressure level variability of up to 20 dB was observed in a room/hallway complex where there were significant acoustic interactions.
- o Resonance conditions in rooms resulted in enhancements of sound pressure levels of about 5 dB. This is much less than for a small model resonator with more rigid walls and for which the associated amplification factor is greater.
- o Available methods that provide good predictions of the resonant frequency of small models with well defined geometry, provide only fair results for rooms having flexible structures and very complex door (neck) openings.

### REFERENCES

1. Davis, Don D. Jr.: Acoustical filters and mufflers. Handbook of noise control, edited by C. M. Harris. McGraw Hill Book Co., Inc., New York, 1957.
2. Ingard, Uno: On the theory and design of acoustic resonators. J. Acoust. Soc. Am., Vol. 25, No. 6, November 1953.
3. Lambert, Robert F.: Study of the factors influencing the damping of an acoustic cavity. J. Acoust. Soc. Am., Vol. 25, No. 6, November 1953.
4. Knudsen, Vern O. and Harris, Cyril M.: Acoustical designing in architecture, American Inst. of Physics, 1978.

TABLE I - COMPARISONS OF MEASURED AND CALCULATED  
CAVITY RESONANCE FREQUENCIES

	Volume $V, m^3$	Neck area $A, m^2$	Neck length $t, m$	Door Config.	$f_H, Hz$ (Calc)	$f_H, Hz$ (meas)
Room A	41.6	2.11 .21	.07 "	Fully open Partly open	11.1 5.9	8-10
Room B	43.5	1.78 .18	" "	Fully open Partly open	10.4 5.5	6-10
Room C	43.5	1.78 .18	" "	Fully open Partly open	10.4 5.5	6- 8 6- 8
Room D	33.7	1.78 .18	" "	Fully open Partly open	11.8 6.2	9 6- 9
Room E	11.8	1.78 .18	" "	Fully open Partly open	19.9 10.5	20 19
Room F	7.3	1.78 .18	" "	Fully open Partly open	25.4 13.4	25 20
Model	.057	.025	.018	Fully open	95.7	95

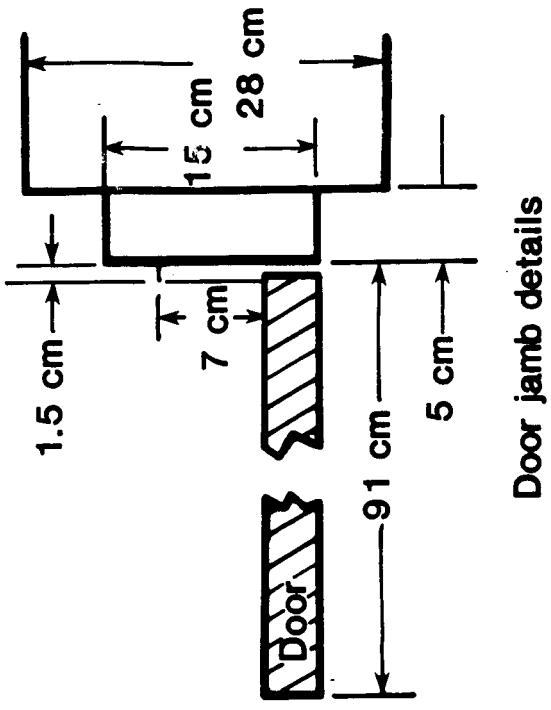

\* Rooms C and D have 1-meter airspace above ceiling

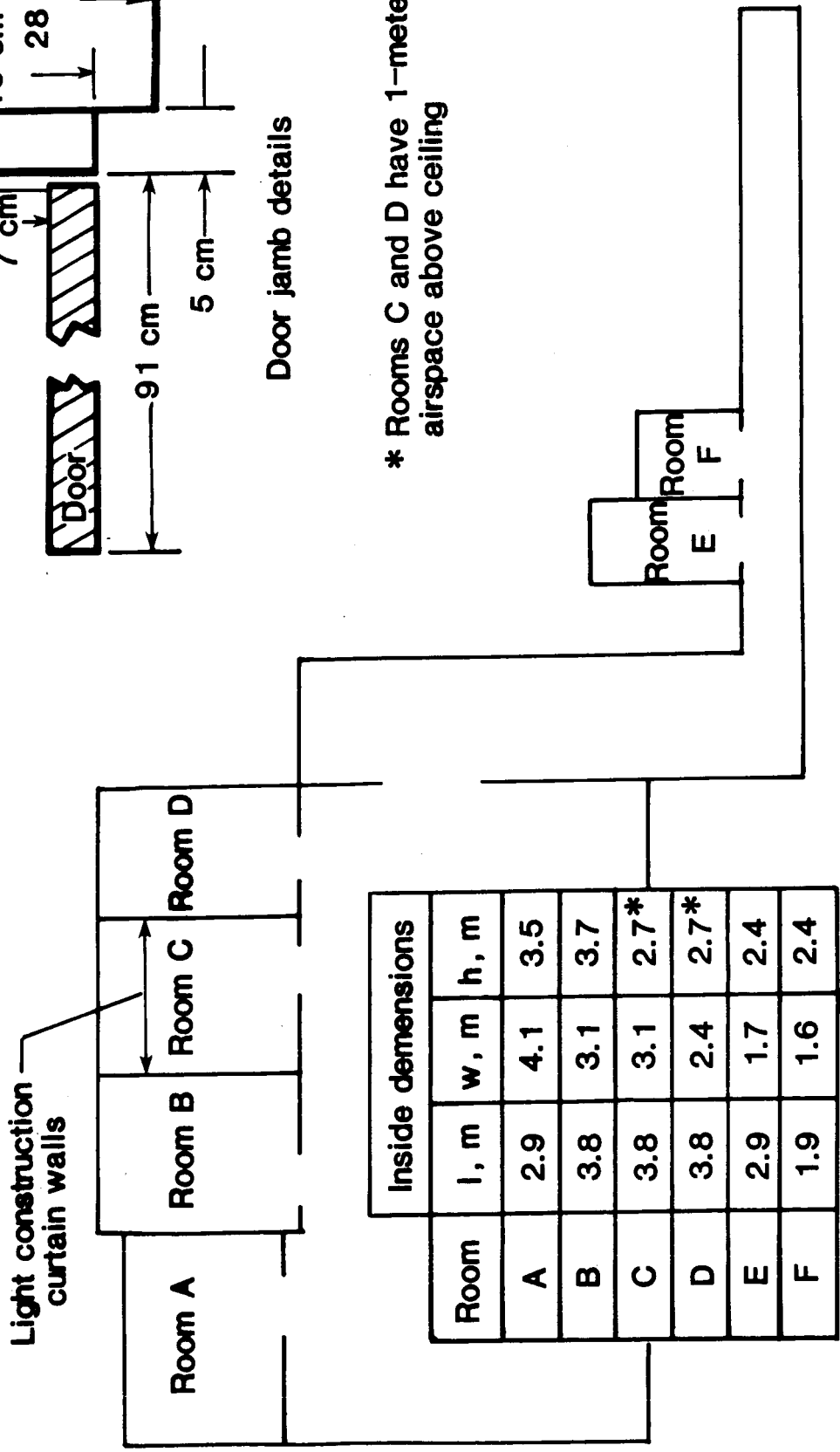

Figure 1. - Plan view layout and dimensions of rooms for which acoustic response data are presented.

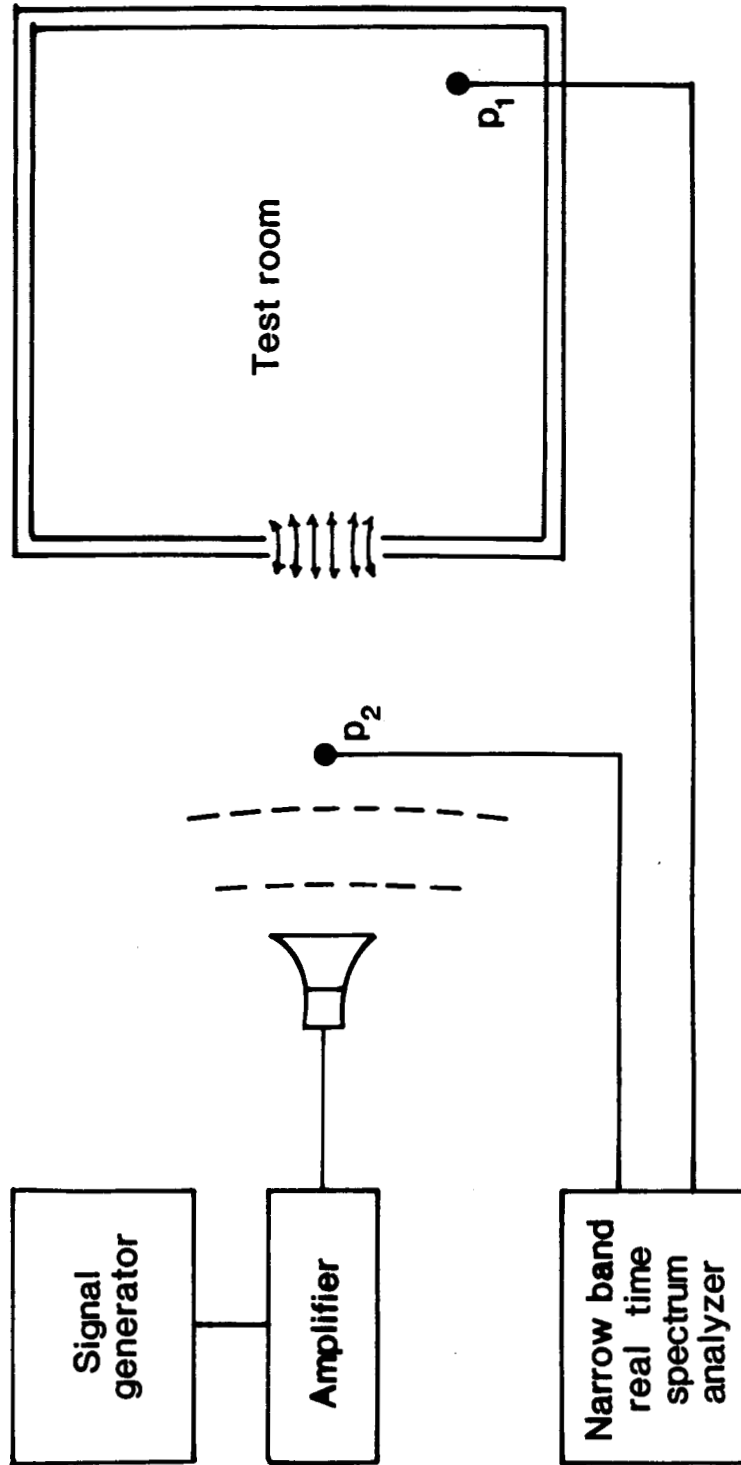

Figure 2. - Schematic diagram of equipment used for the acoustic excitation and measurement of a test room.

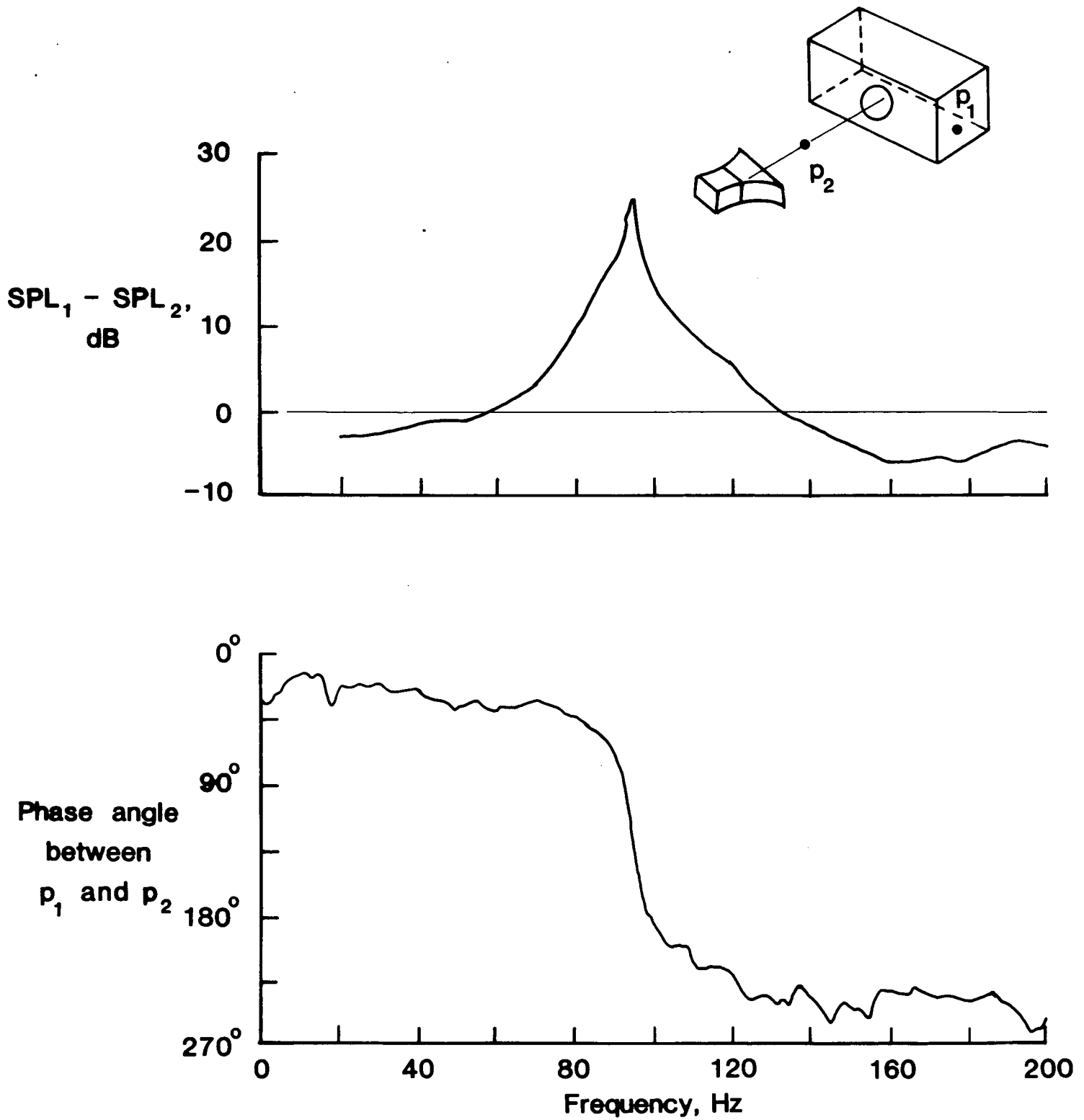

Figure 3. - Low frequency response of a model resonator due to excitation by broadband noise from a loudspeaker.

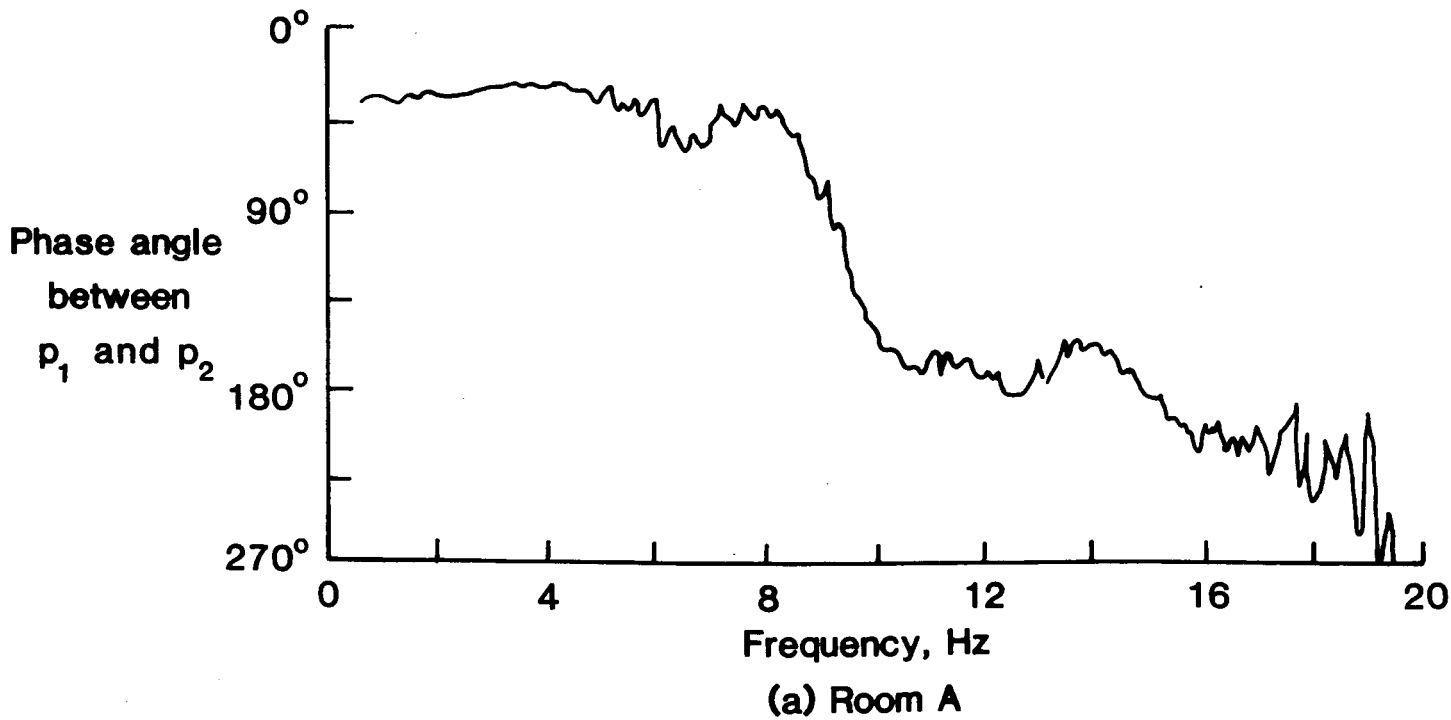
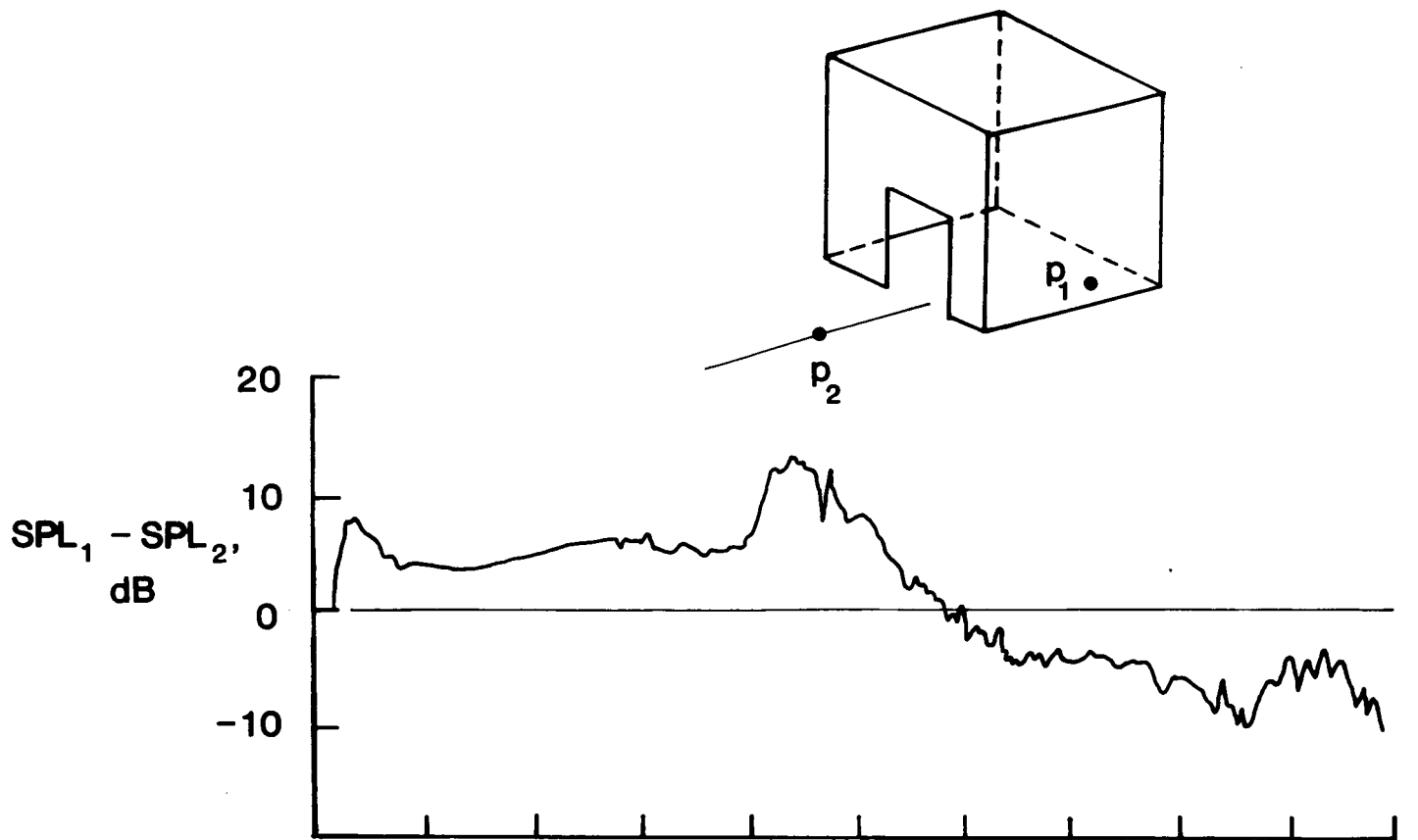
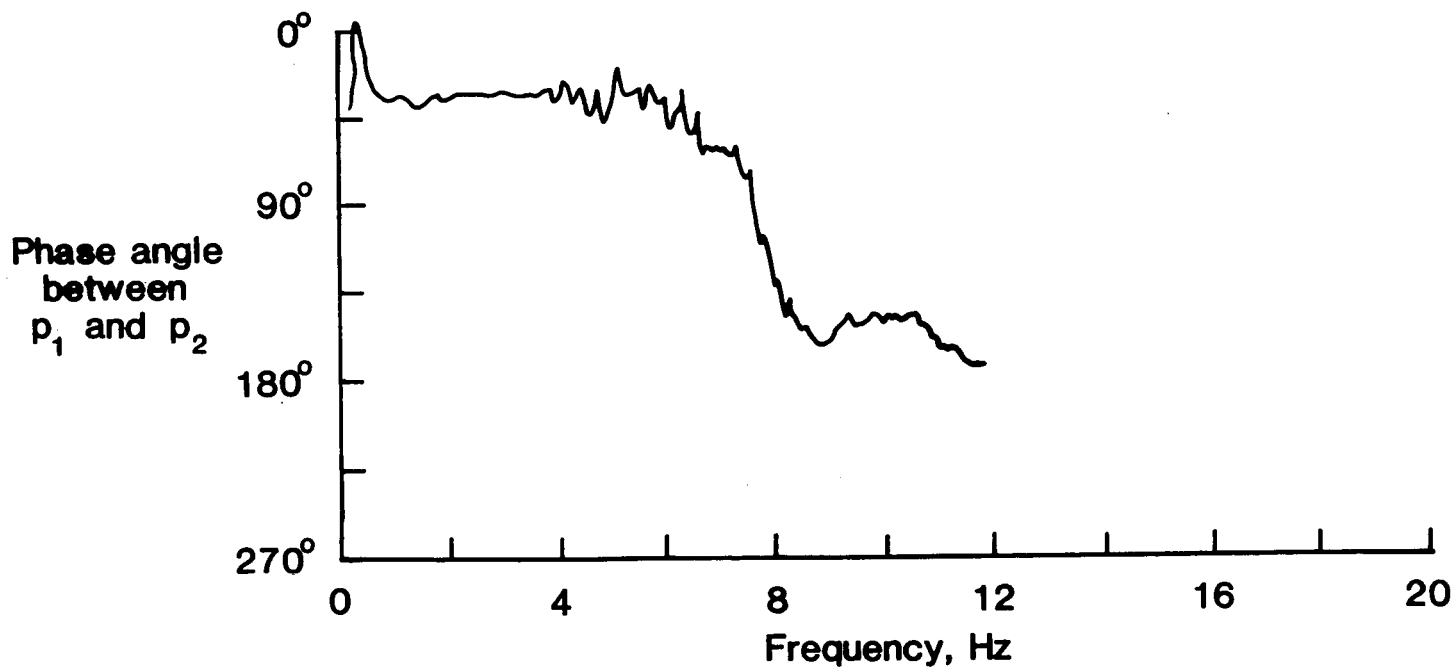
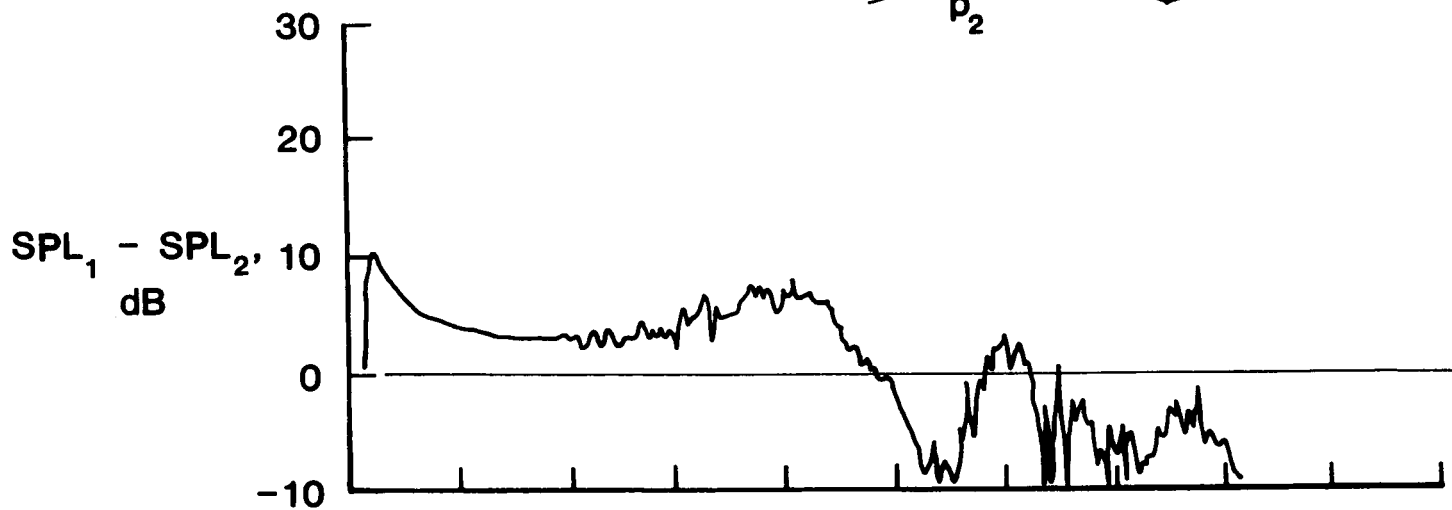
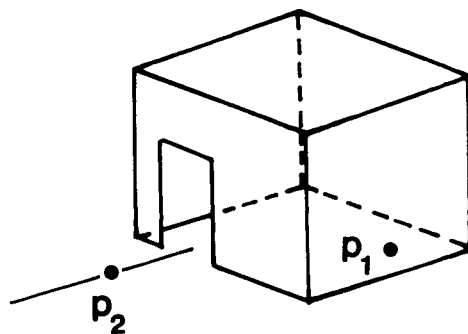
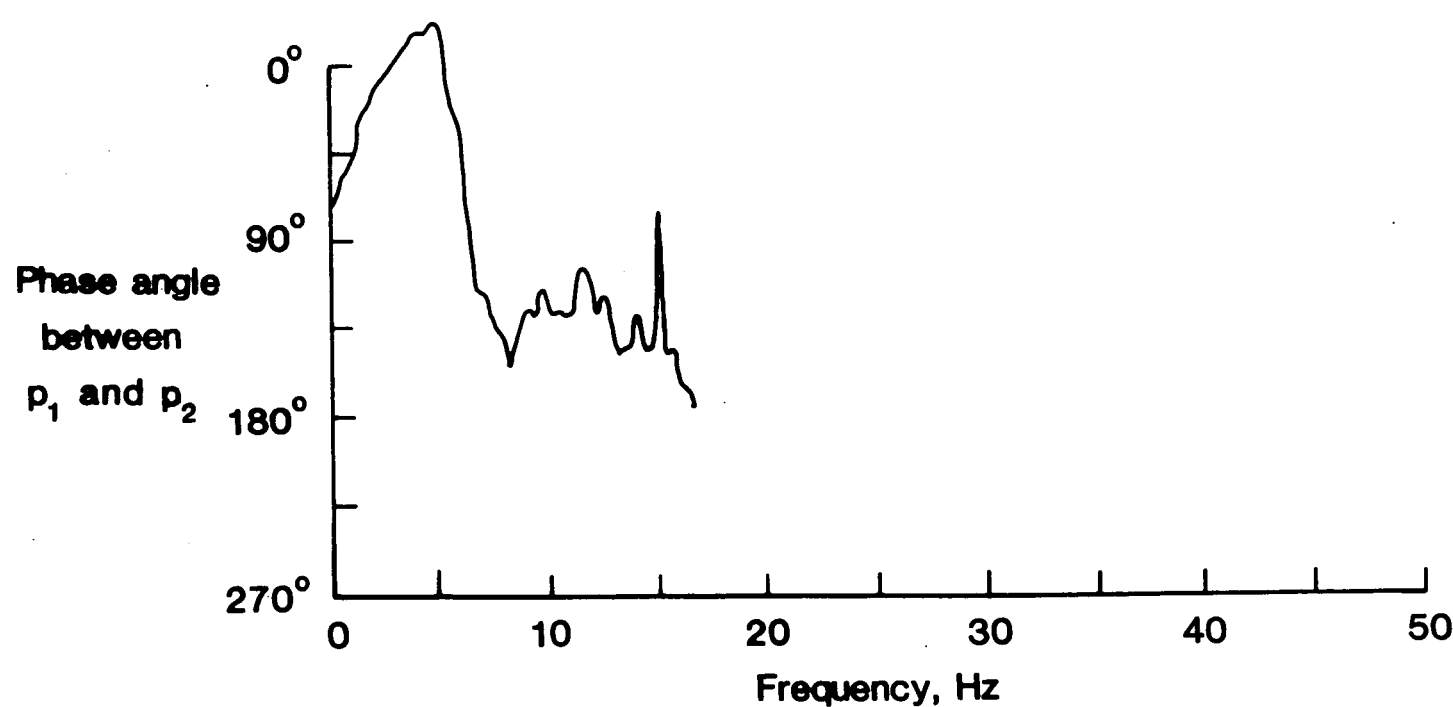
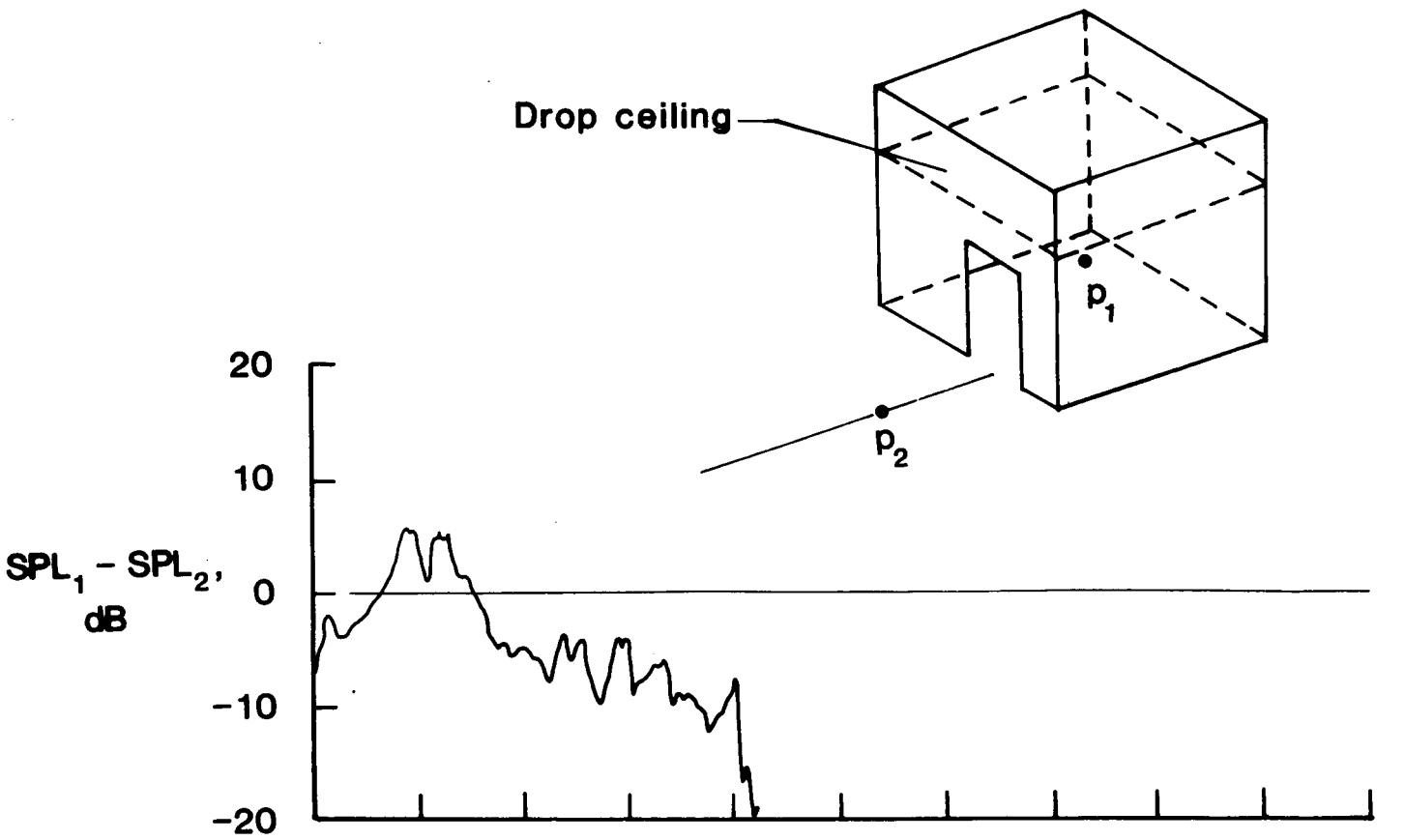

Figure 4. - Low frequency responses of rooms A and B due to excitation by ambient noise.



(b) Room B



(a) Room C

Figure 5. - Low frequency responses of rooms C and D due to excitation by ambient noise.



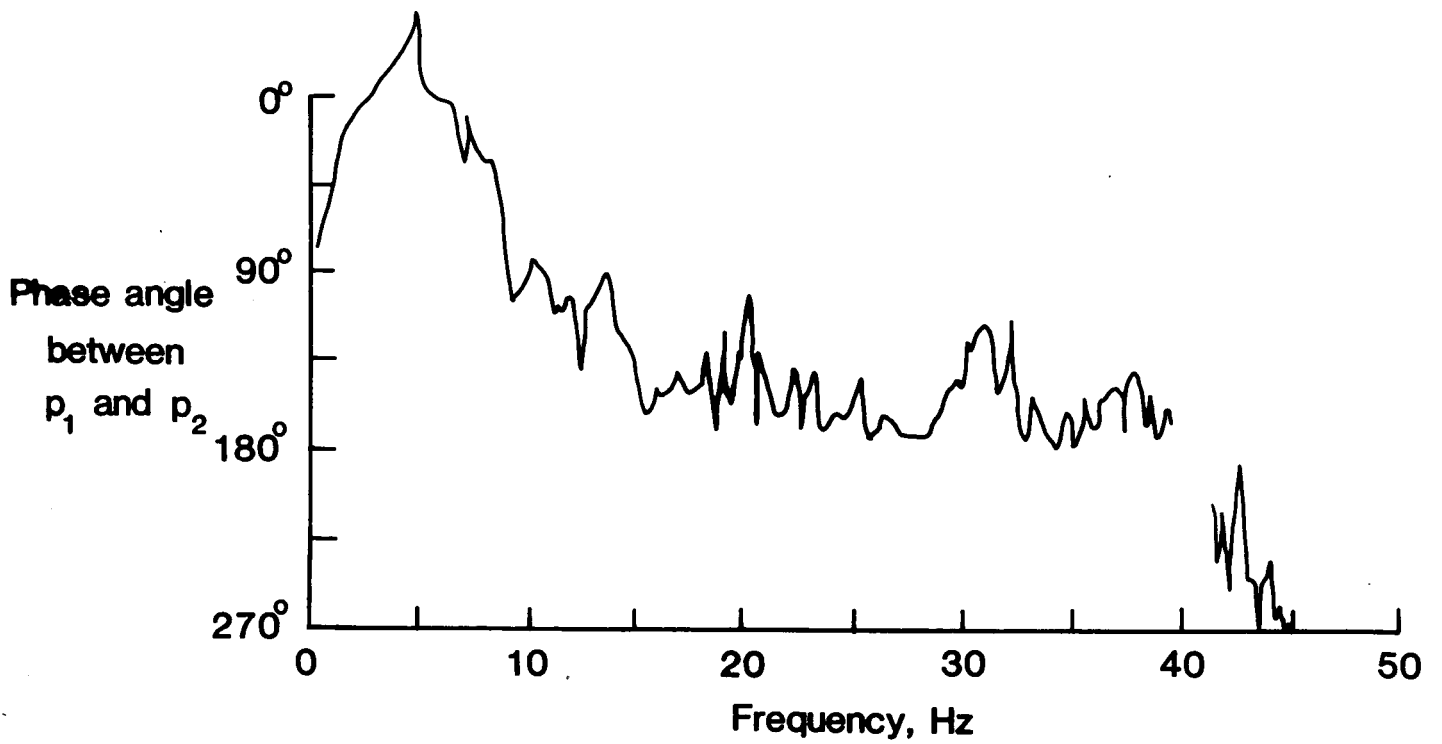
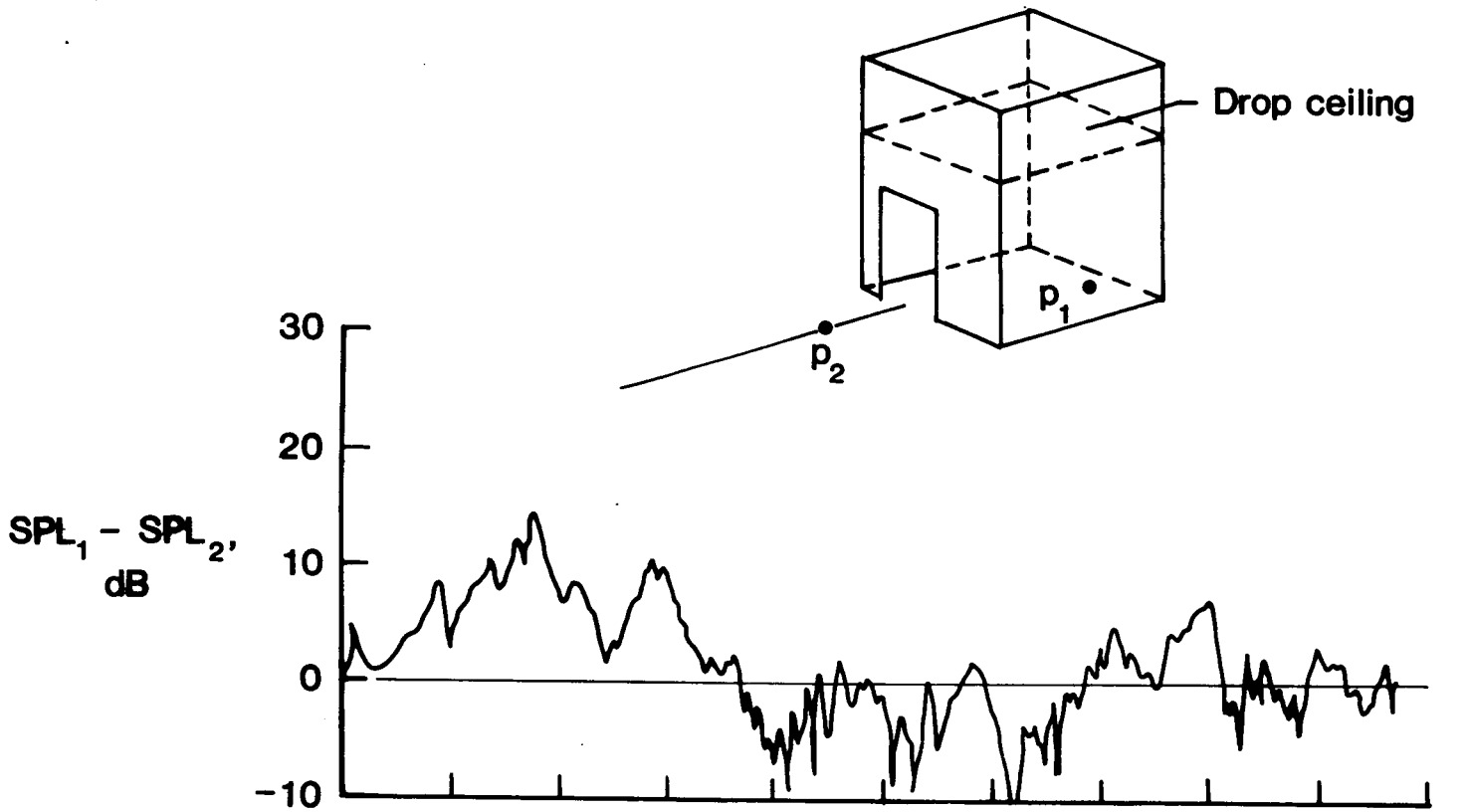

(b) Room D

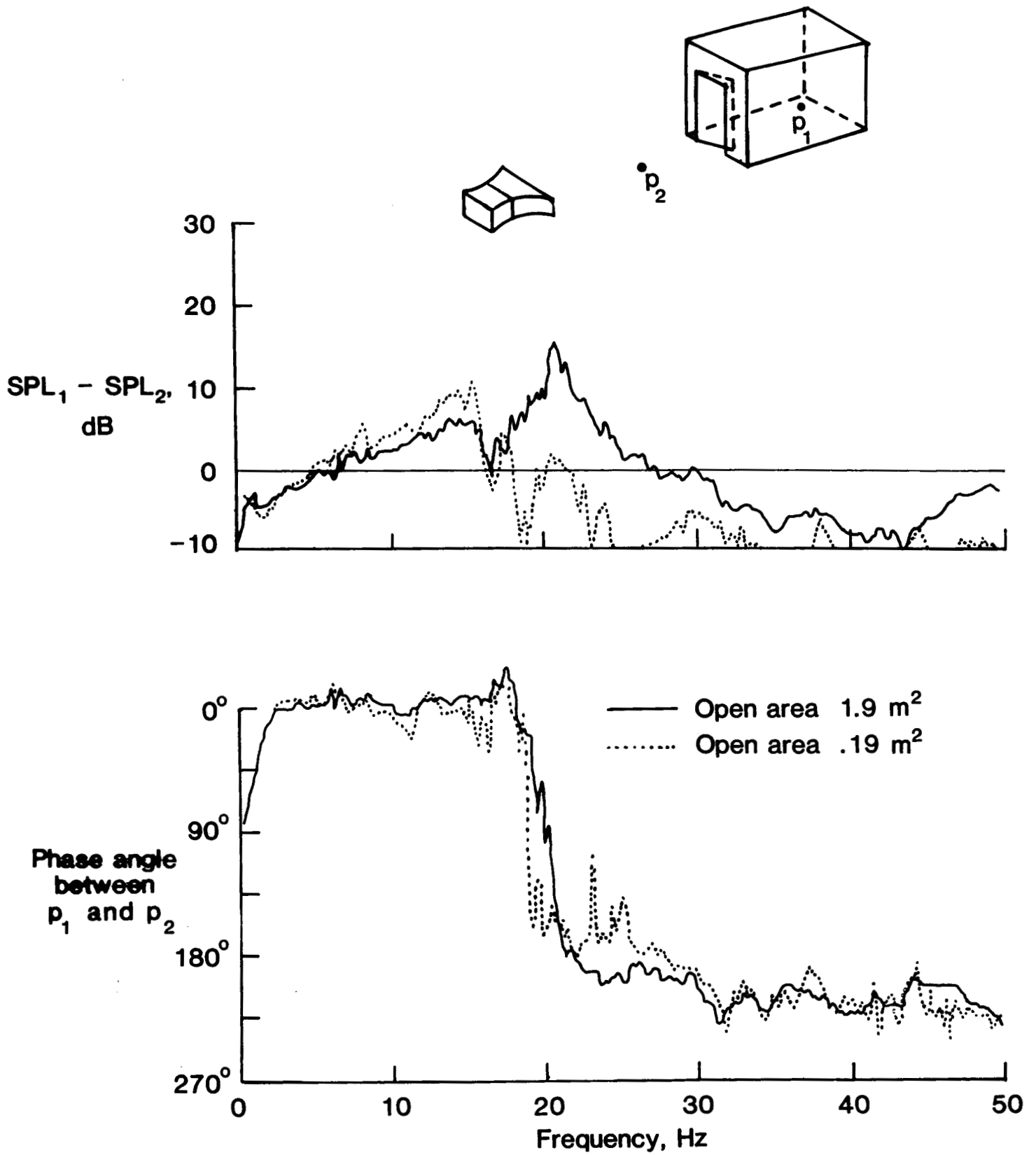

Figure 6. - Low frequency response of room E due to broadband noise excitation from a loudspeaker.

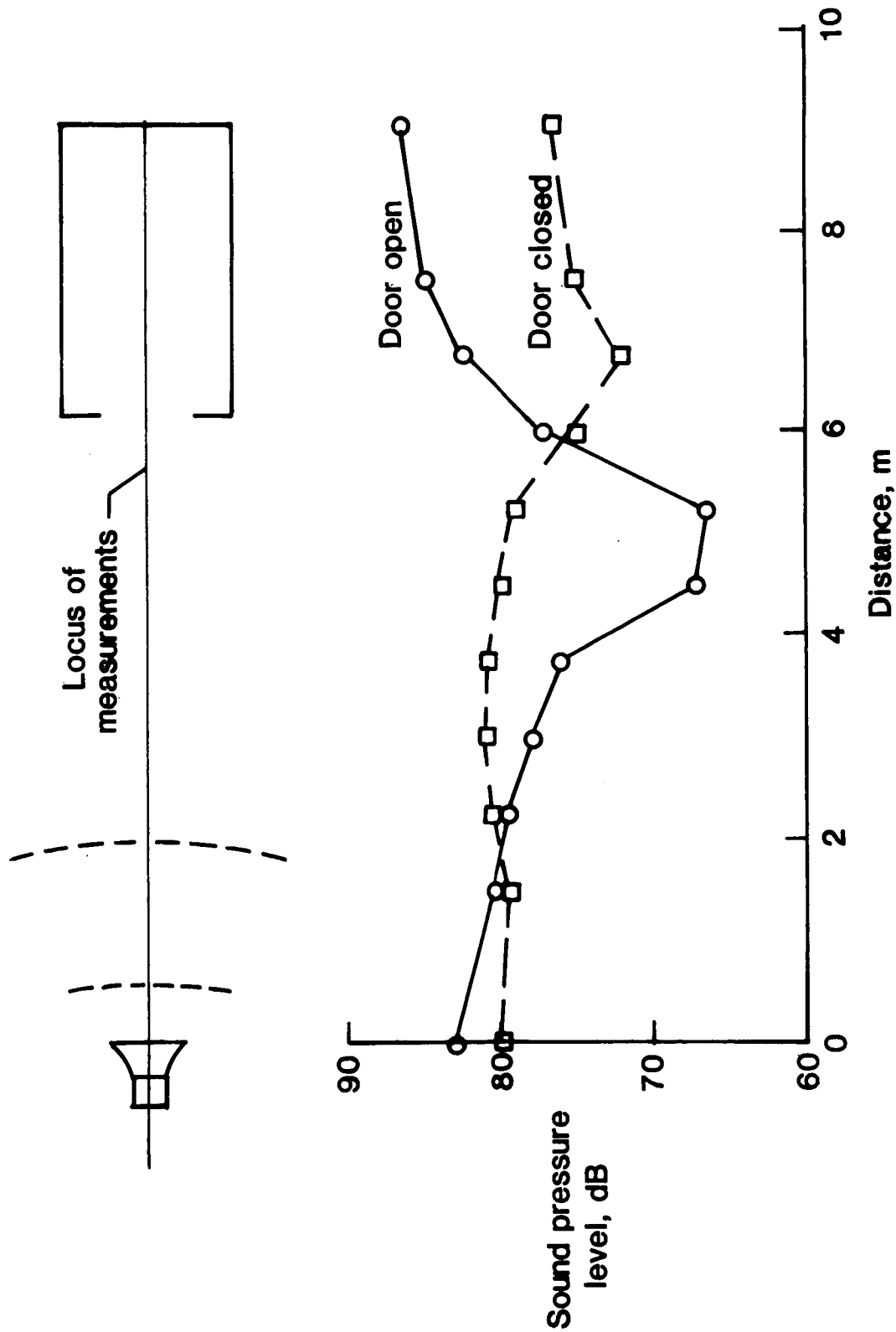

Figure 7. - Sound pressure level gradients inside and outside of room E due to pure tone excitation by a loudspeaker at a frequency of 21 Hz for both the door open and door closed configurations.

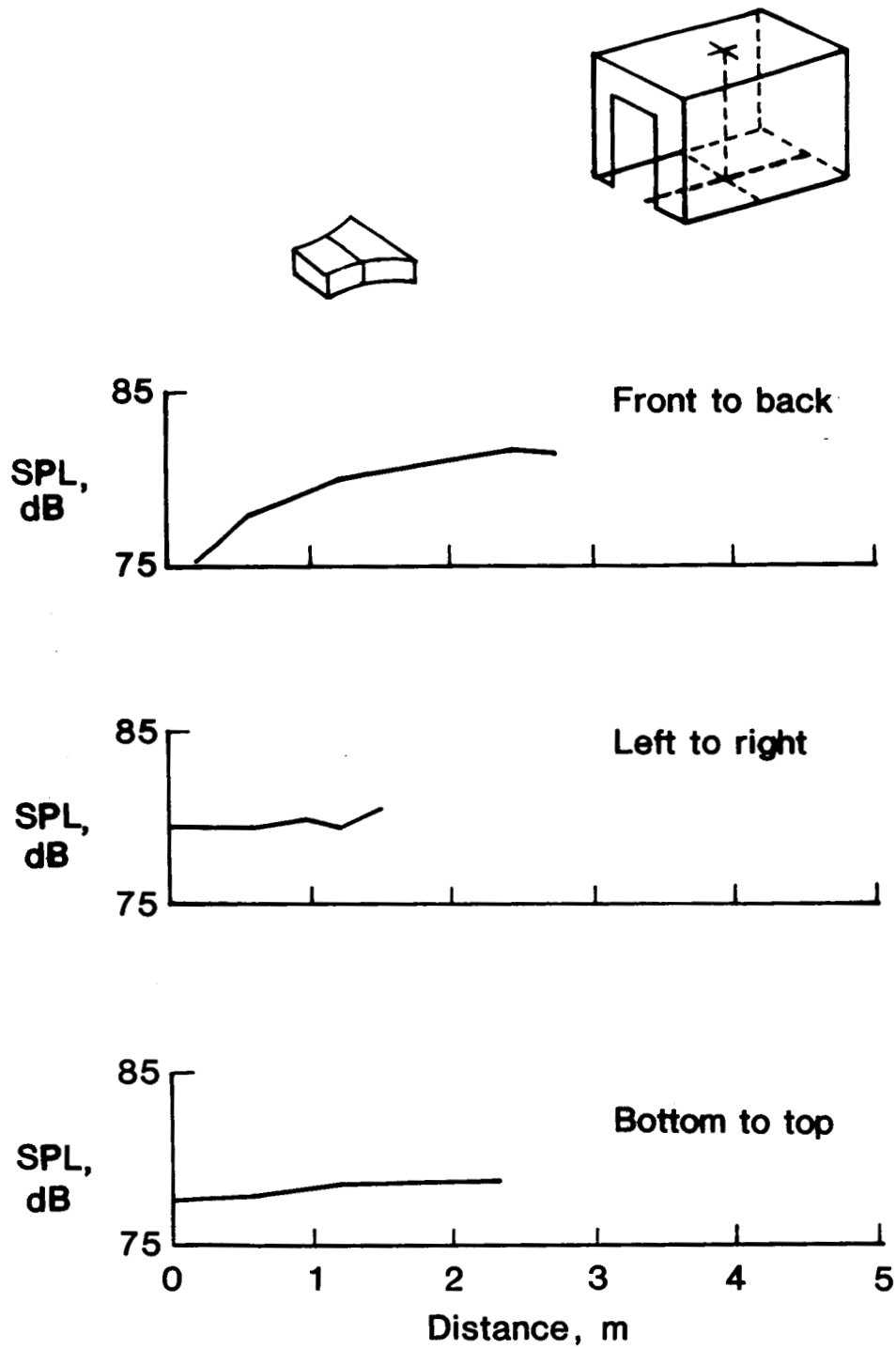

Figure 8. - Sound pressure level distributions in three directions inside of room E for pure tone excitation by a loud-speaker at a frequency of 21 Hz for the door open condition.

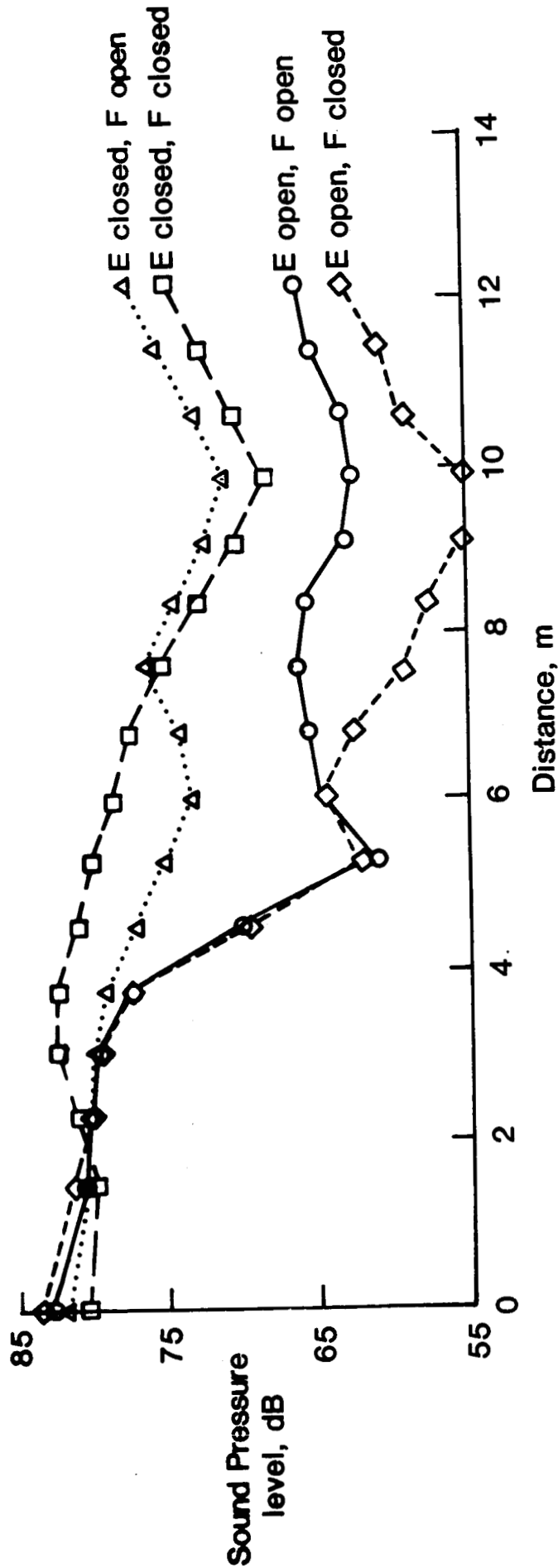
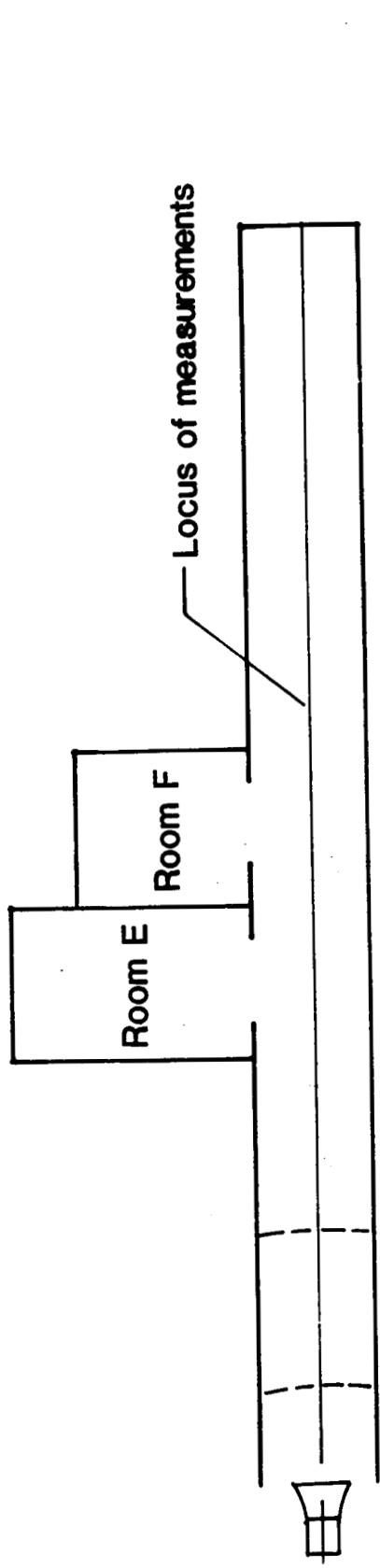
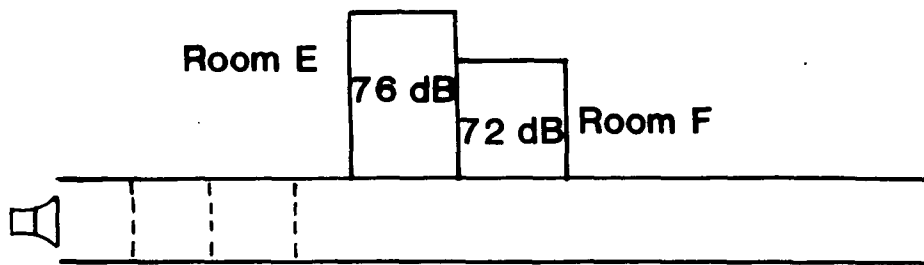
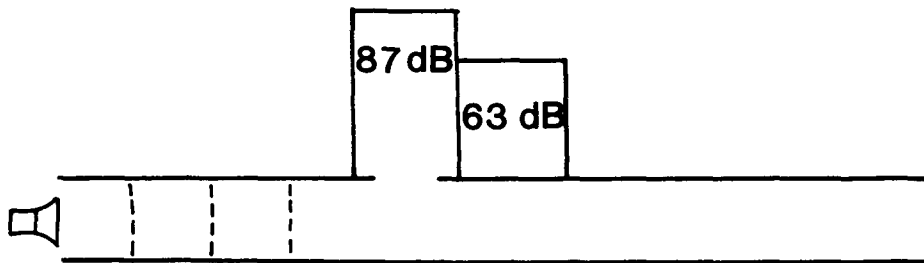

Figure 9. - Sound pressure level gradients in hallway adjacent to rooms E and F due to pure tone excitation by a loudspeaker at a frequency of 21 Hz, for four different door opening configurations. Input power to loudspeaker is constant.



(a) E closed, F closed



(b) E open, F closed

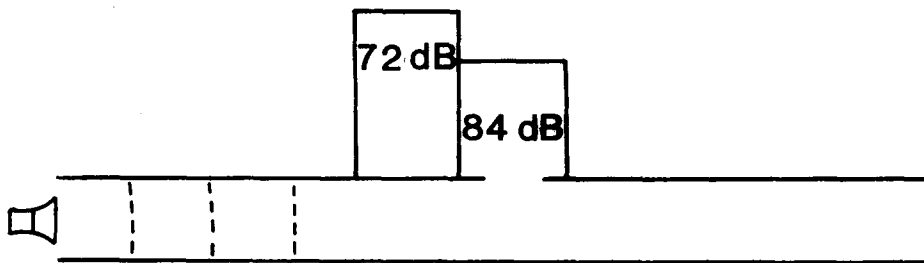

(c) E closed, F open

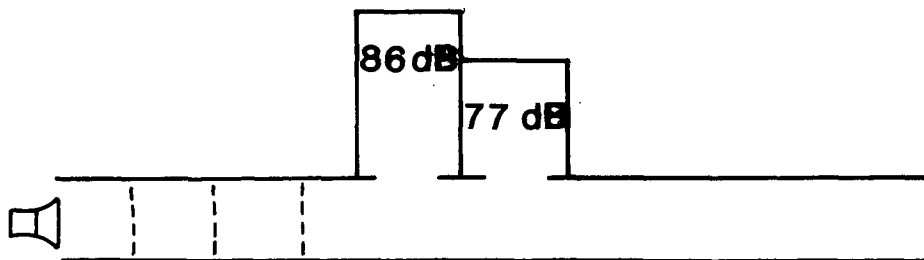

(d) E open, F open

Figure 10. - Maximum values of sound pressure level in rooms E and F due to pure tone excitation by a loudspeaker at a frequency of 21 Hz for various door opening combinations.

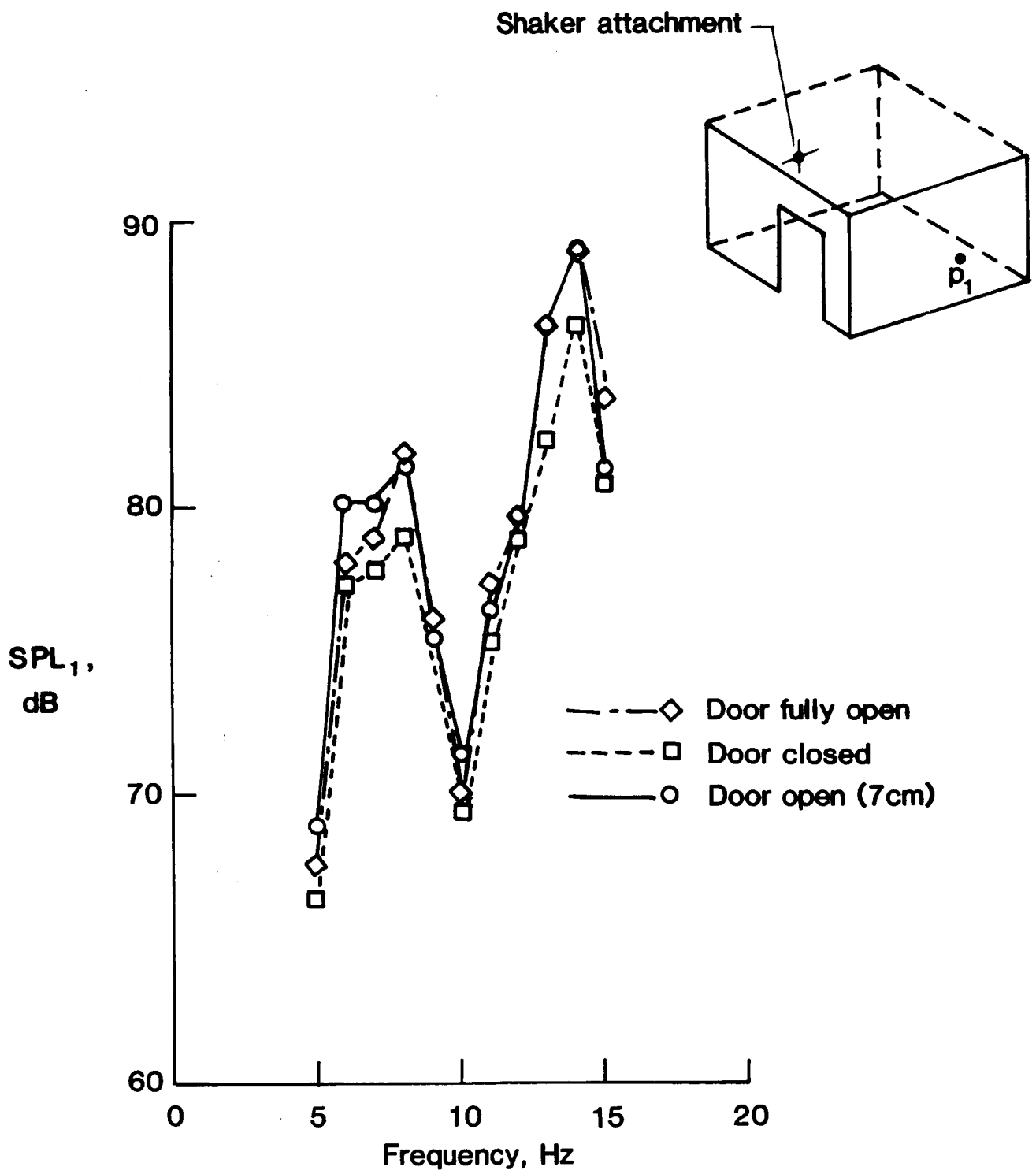
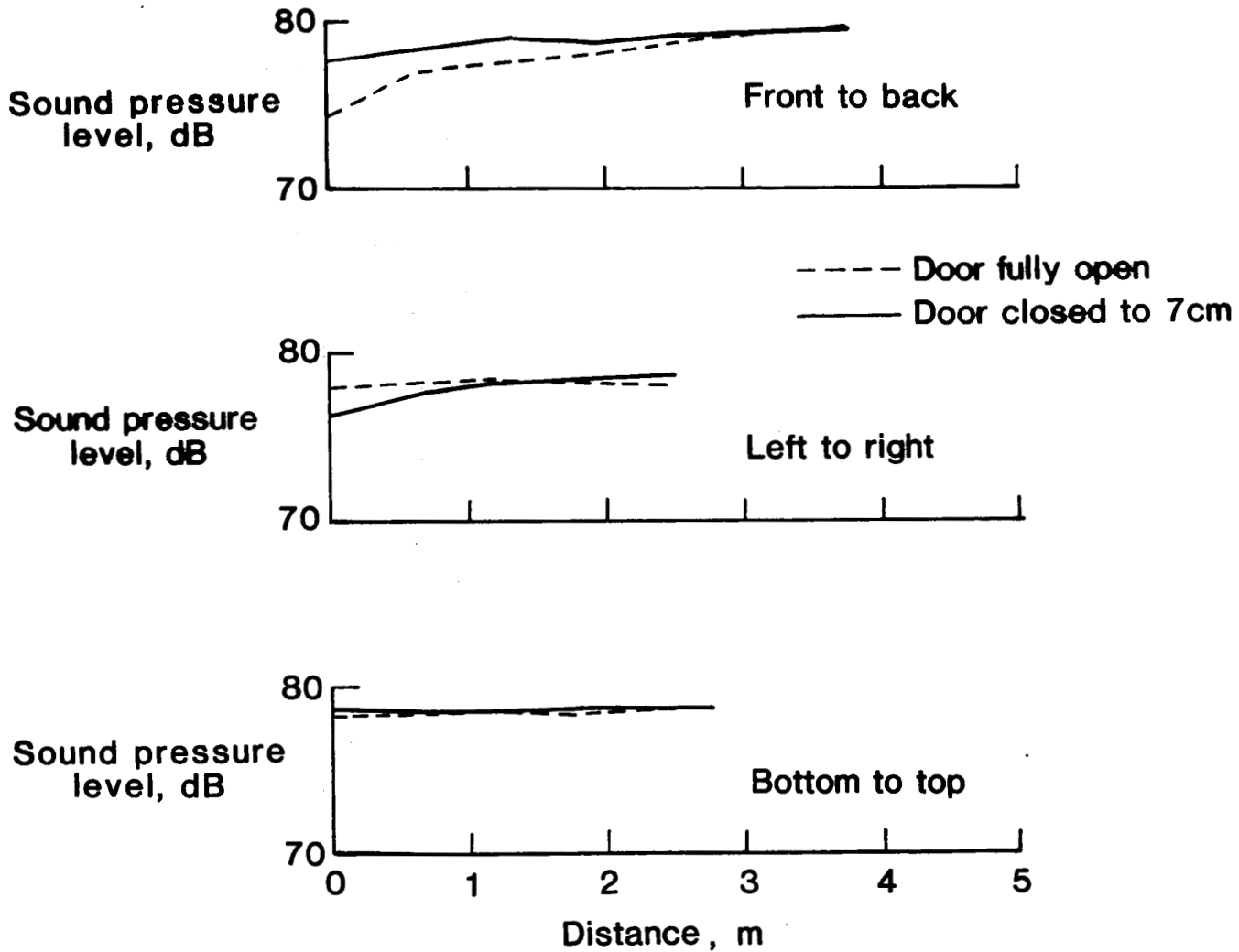
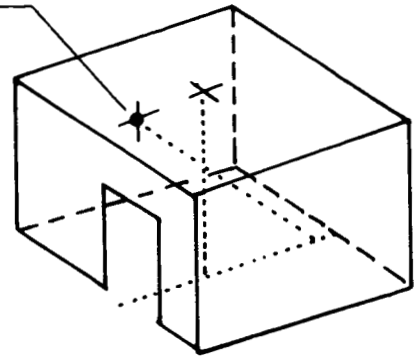

Figure 11. - Low frequency response of room C due to discrete frequency vibratory excitation by a shaker.

Shaker attachment



(a) Excitation frequency = 8 Hz

Figure 12. - Sound pressure level distributions in three directions inside of room C due to a vibratory input force of 10 lb.



Shaker attachment

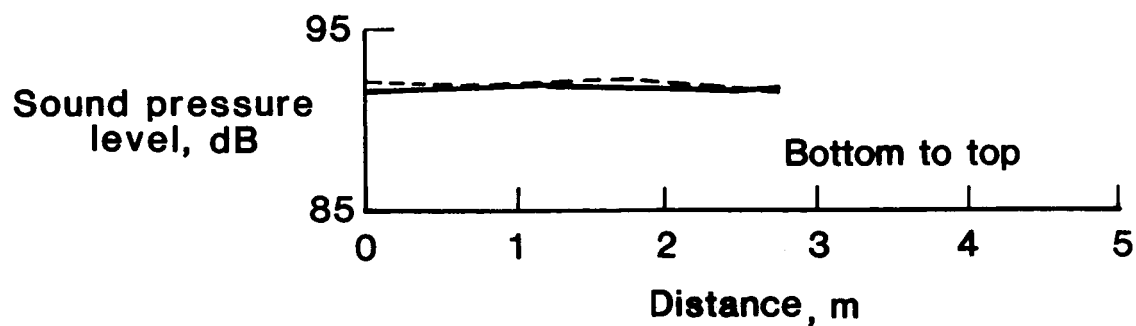
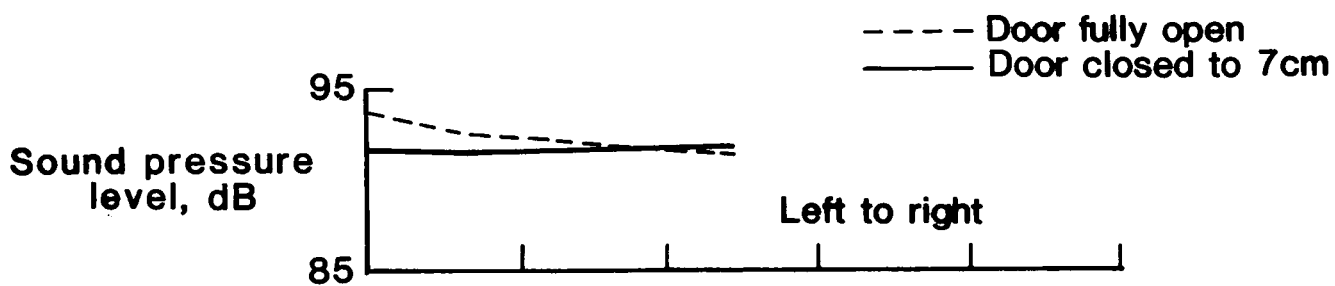
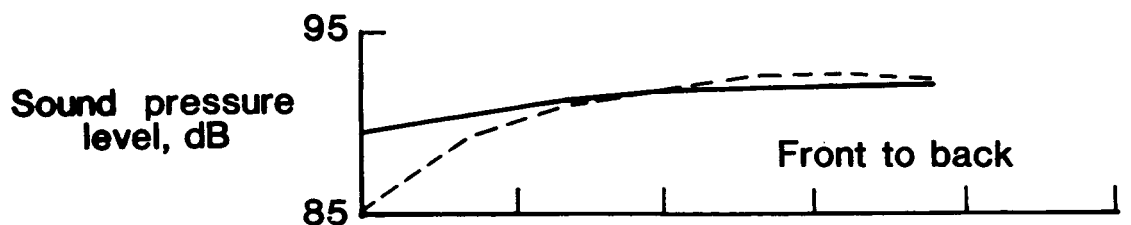
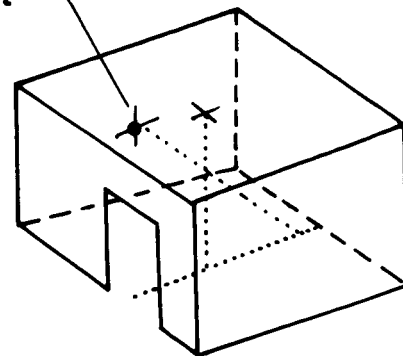

(b) Excitation Frequency = 13.5 Hz

Figure 12. - (concl.)

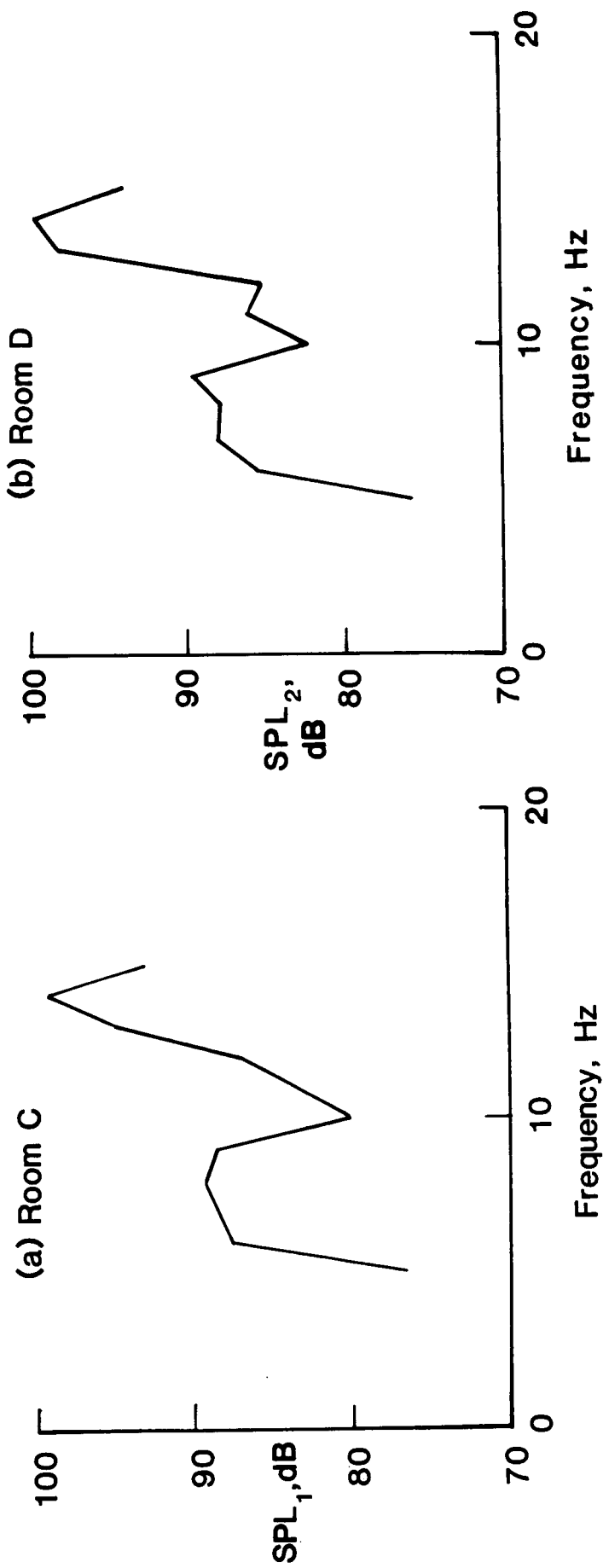
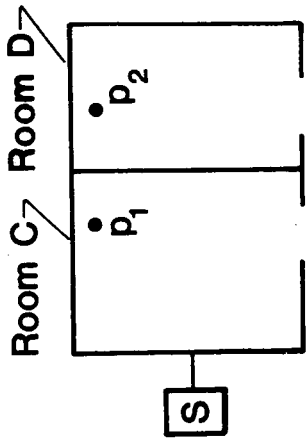

Figure 13. - Measurements of sound pressure level in rooms C and D due to discrete frequency vibratory excitation of one wall of room C by a shaker.

1. Report No. NASA CR-178173	2. Government Accession No.	3. Recipient's Catalog No.	
4. Title and Subtitle The Helmholtz Resonance Behavior of Single and Multiple Rooms		5. Report Date September 1986	6. Performing Organization Code
		8. Performing Organization Report No.	
7. Author(s) Harvey H. Hubbard and Kevin P. Shepherd		10. Work Unit No.	
9. Performing Organization Name and Address The Bionetics Corporation 18 Research Drive Hampton, VA		11. Contract or Grant No. NAS1-16978	
		13. Type of Report and Period Covered Contractor Report	
12. Sponsoring Agency Name and Address National Aeronautics and Space Administration Washington, DC 20546		14. Sponsoring Agency Code 776-33-41-02	
15. Supplementary Notes This report was prepared jointly by Harvey H. Hubbard and Kevin P. Shepherd of the Bionetics Corp. under contract NAS1-16978. Langley Technical Monitor: Clemans A. Powell.			
16. Abstract This paper presents the results of some exploratory measurements of the noise fields inside rooms which are excited to resonance either acoustically or mechanically. The data illustrate the nature and extent of the sound pressure level enhancements in single rooms and also how multiple rooms may resonate by means of either acoustic or mechanical coupling.  Sound pressure level enhancements of about 5 dB were measured during resonance of rooms having flexible walls. For such conditions the sound pressure levels in the room were essentially uniform and in phase. Variability of up to 20 dB was measured in a room - hallway complex having significant acoustic interactions. Resonant frequency prediction methods which work well at model scale, give only fair results for rooms.			
17. Key Words (Suggested by Author(s)) Room Acoustics Noise Inducted Vibrations Building Acoustics Helmholtz Resonance		18. Distribution Statement Unclassified - Unlimited  Subject Category - 71	
19. Security Classif. (of this report) Unclassified	20. Security Classif. (of this page) Unclassified	21. No. of Pages 26	22. Price A03