The hidden geometry of deformed grids: or, why space syntax works, when it looks as though it shouldn't

B Hillier

Bartlett School of Graduate Studies, University College London, Gower Street, London WC1E 6BT, England; e-mail: b.hillier@ucl.ac.uk

Received 10 February 1998; in revised form 30 September 1998

Abstract. A common objection to the space syntax analysis of cities is that even in its own terms the technique of using a nonuniform line representation of space and analysing it by measures that are essentially topological ignores too much geometric and metric detail to be credible. In this paper it is argued that far from ignoring geometric and metric properties the 'line graph' internalises them into its structure of the graph and in doing so allows the graph analysis to pick up the nonlocal, or extrinsic, properties of spaces that are critical to the movement dynamics through which a city evolves its essential structures. Nonlocal properties are those which are defined by the relation of elements to all others in the system, rather than those which are intrinsic to the element itself. The method also leads to a powerful analysis of urban structures because cities are essentially nonlocal systems.

1 Preliminaries

1.1 The critique of line graphs

Space syntax is a family of techniques for representing and analysing spatial layouts of all kinds. A spatial representation is first chosen according to how space is defined for the purposes of the research—rooms, convex spaces, lines, convex isovists, and so on—and then one or more measures of 'configuration' are selected to analyse the patterns formed by that representation. Prior to the researcher setting up the research question, no one representation or measure is privileged over others. Part of the researcher's task is to discover which representation and which measure captures the logic of a particular system, as shown by observation of its functioning.

In the study of cities, one representation and one type of measure has proved more consistently fruitful than others: the representation of urban space as a matrix of the 'longest and fewest' lines, the 'axial map', and the analysis of this by translating the line matrix into a graph, and use of the various versions of the 'topological' (that is, nonmetric) measure of patterns of line connectivity called 'integration' (Hillier and Hanson, 1984; Hillier et al, 1982; Steadman, 1983). This line graph approach has proved quite unexpectedly successful. It has generated not only models for predicting urban movement (Hillier et al, 1987; Hillier et al, 1993; Penn et al, 1998; Peponis et al, 1989; Read, 1999) but also strong theoretical results on urban structure, and even a general theory of the dynamics linking the urban grid, movement, land uses, and building densities in 'organic' cities (Hillier, 1996a; 1996b). It has also yielded a practical method for the application of these results and theories to design problems (Hillier, 1993), which now has a substantial portfolio of projects.

Many are, however, troubled by these results, not because the empirical correlations are doubted, or because the theoretical reasoning is thought unsound, but because the foundations of the method seem insecure. How can so much of the geometric and metric complexity of urban space be discounted, and so much weight put on a simple line representation, and a nonuniform one at that? Why should topological rather than metric measures then be chosen, especially in view of the emphasis on movement where metric variables must be expected to play a role? And why should so much emphasis be placed on a single type of measure, based on topological 'depth' in

the graph? Can such an apparent simplification of the geometric complexity of urban space then be considered a realistic foundation for a theory? Is there perhaps some way in which the strategy of line graphs can be given a more secure theoretical foundation?

1.2 The structure – order problem

The external critique of line graphs has also been reflected in a debate within the space syntax community about the relation of geometry and topology in urban systems, under the rubric of the ‘structure–order’ problem. It has always been clear that, historically, space syntax analysis turned attention away from geometrical notions of spatial order in the study of buildings and cities and pointed to spatiofunctional patterns which, formally speaking, were closer to topology than to geometry. This distinction was clarified by Hanson (Hanson, 1989) who distinguished between the nongeometric ‘structures’ identified in urban space by space syntax analysis and the type of geometrical ‘order’ found in the plans of ideal towns. The latter could be easily intuited, because geometrically similar elements were put into geometrically similar relations, and this made it possible for the eye to see the pattern ‘all at once’. The former could not be easily intuited as a whole, because neither locally similar elements nor relations could be easily discerned, but they were discovered practically as patterns of everyday space use and movement. It was these functional patterns of space that were picked up by space syntax analysis as structures.

The structure – order distinction has proved a very useful heuristic but, as time has gone by, it has become clear that further clarification was needed, if for no other reason than because the structures that are found in the typical ‘deformed grids’ that characterise most towns and cities have themselves strong geometric aspects. At a more general level it is also clear that, on a scale from geometrical chaos (in the old sense) to order, cities are quite close to the order pole and utterly remote from chaos. They are ‘nearly ordered’, not ‘nearly chaotic’. What then is the role of this geometrical order and how does it relate to the more organic structures that space syntax has identified? How was it possible to discount this geometric order in the line graph analysis and still obtain apparently useful results? Is geometric order perhaps another dimension of urban structure? Or is it constructively linked to the structure patterns which have proved so useful in deciphering the relation between space and function in cities?

The aim of this paper is to try to answer both of these questions—the critique of the line graph and the structure–order problem—by showing that they are essentially the same question: what is the role of geometry in constructing the patterns of space that characterise cities and how does it relate to the structures identified through line graph analysis? The answer proposed is that line graph analysis does not ignore the geometric properties of space but internalises them into the graph, and it is precisely because it does so that it is able to pick up the nonlocal, or extrinsic, properties of spaces that are critical to the movement dynamics through which a city evolves its essential structures. Nonlocal properties are those which are defined by the relation of elements to all others in the system, rather than those which are intrinsic to the element itself. The method also leads to a powerful analysis of urban structures because cities are essentially nonlocal systems.

1.3 Outline of the argument

The argument is presented in a series of stages. Axial maps of cities are first examined from a geometrical point of view and are shown to manifest consistent ways of relating geometric variables such as line length and angle of intersection, so that even apparently irregular cities have a surprising degree of geometric order in their axial maps. It is also shown that the emergent global structures of cities, even the largest, seem to

have pervasive geometric properties which combine aspects of both orthogonal and radial grids, two of the prime 'rationalist' geometric notions by which designers have sought to create ideal cities. In spite of this apparently pervasive geometry, it is then explained, on the basis of a simple model of the 'essential urban dynamic', how space syntax seems to account for the spatial and functional dynamics of cities without reference to geometry. How can this be? An investigation is first made of graphs. It is shown that there are strong theoretical reasons why graphs cannot in themselves carry the weight that has been apparently assigned to them in the line graph analysis because that would require them to be both more predictable and more knowable than they are. This is an important clue. I then show that the general role of geometric order in cities is to create a world in which graphs do become predictable and knowable, but both are a product of geometry seen as graphs, not of graphs themselves. I then ask how this geometric order arises, and show that exactly the kinds of geometric order that have been described can be generated theoretically by the familiar need to minimise mean trip lengths in the system for two kinds of movement: circulation within the system from all origins to all destinations, and movement in and out of the system to neighbouring systems. Next I describe how the key geometrical properties generated by movement are internalised into the line graphs and create its structure as a pattern of connectivities. Once these properties are internalised into the graph, it becomes possible for the graph to do its work of bringing to light the crucial nonlocal properties of the lines and of the system as a whole.

2.0 The geometry of axial maps

2.1 Counting angles, measuring lines: the pervasive geometry of deformed grids

Just how 'nearly geometrical', then, are the deformed grids that characterise most cities? We can find the answer by the usual technique of looking carefully, counting, and measuring. Consider, for example, the axial map of a part of London shown in figure 1 (over), analysed and shaded from dark to light according to the 'local integration' values of each line calculated by summing depths only for lines which intersect the root line, and those which intersect these (Hillier 1996a). These values have been shown to be the best predictors of pedestrian movement (Hillier, 1996a; Penn et al, 1998; Read, 1999)⁽¹⁾. As in any axial map, each line ends where it is incident on the face of a building, and (with the exception of end lines in culs-de-sac) an incident line will normally intersect with another which is more or less parallel to the building face. This intersection will define the principal route continuation, or continuations, for the incident line. If we begin to measure the angles formed by these incident and parallel lines, we find that a surprisingly high proportion are either near right-angle connections, usually within about 15° of 90°, or very obtuse angles, usually within about 15° of a direct 180° continuation. Incident-parallel angles closer to 45° occur more rarely. Where they do they usually indicate a clear choice of direction in the larger scale grid structure, and even then one of the two lines making up the fork is usually an approximately linear continuation. If we take other intersections, where neither line is incident on a building (and both therefore continue to other intersections), the range is even more restricted, with the vast majority approximating a right angle. In effect, an unexpectedly high proportion of the angles of incidence in the axial map are concentrated within little more than a third of the possible range. Such probabilistic bias in a geometric variable is unlikely to have occurred by chance. It suggests some kind of consistent constructive process at work.

⁽¹⁾The maps referred to in this paper can be obtained on request from the Space Syntax Laboratory, UCL, London.

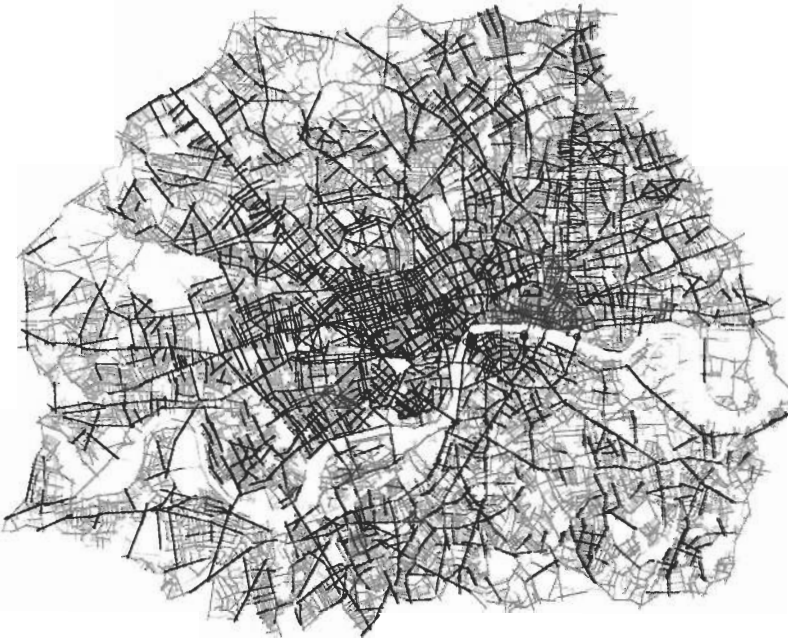

Figure 1. Axial map showing the logarithm of local integration in London.

Looking a little further, we find that angles of intersection have an equally improbable relation to another geometric variable: line length. For the most part, we find that highly obtuse angles of incidence are associated with longer lines and the near right angles with shorter lines. In general, the longer the line, the more likely it is to have a highly obtuse angle of incidence at (or close to) one or both of its ends. Conversely, the shorter the line, the more likely it is to have a near right angle of incidence at its end. With less consistency, though with enough to be suggestive, the 45° lines tend to be shorter than the obtuse angle lines but longer than the near right-angle lines. We also find that these consistent relations of lengths and angles seem to form sequences or clusters. For example, if we follow a longish line to its end and find the obtuse angle of incidence that connects it to the next line, the chances are that this line will also be longish and will also end in an obtuse angle of incidence. It is this that creates the 'slightly sinuous' routes that crisscross London and that are clearly picked out by the analysis shown in figure 1.

This makes route finding across London a kind of 'Markov process', in which what happens next is influenced by what has already happened. The usefulness of this property in direction finding must be considerable. The more long lines and obtuse angles of incidence you have moved through, the higher the chance that the next line will be similar in both respects—though, of course, with significant exceptions. Conversely, if we are in an environment in which we experience a series of near right-angle connections, then it is likely that in following a right-angle change of direction we will be offered another before long. Again, the Markov nature of the movement process seems helpful in understanding the kind of spatial structure we are in.

If we carry out a similar analysis for a city which at first sight seems as axially different as possible, say, the Iranian city of Hamedan (Karimi, 1998) shown in figure 2, we find that the lines are in general shorter, and the long-line angles of incidence sharper, giving the axial map a much more broken-up feel, but a similar broad distribution of angles is found, the same type of relation between line lengths and angles of incidence, and the same



Figure 2. Axial map showing the logarithm of global integration of Hamedan.

Markov tendency. In Hamedan long wandering paths, made up of obtuse angle line intersections, pass through the city, many from central towards peripheral areas, and near right-angle lines prevail adjacent to these paths, though forming for the most part local sequences rather than grids. The precise geometric parameters of line length and angles of incidence are set differently but the general process of ‘geometric construction’ is in these respects strikingly similar. In general we will find that this is the case in cities. However variable the precise spatial morphology of the city, we will usually find that it is constructed through consistent relations of some kind between the two prime geometric variables of the axial map: line lengths and angles of incidence.

2.2 The geometry of direction giving

This ‘geometric construction’ underlying the typically deformed grids of cities tends to be confirmed by the ways in which we give directions. It is often said that direction giving supports the ‘landmark’ theory of urban form, as set out by Lynch (1960) and others. In fact, for the most part the directions we give are directly influenced by the kinds of geometric relation we have just described. For example, if we say “carry on in this direction”, we imply not that the road is straight but that there is the kind of ‘more or less’ linearity we have noted, that is, a fairly straight continuation through oscillating obtuse angle connections, approximating if not an overall line then at least a consistent direction. We might add a landmark—say, keep going past the windmill—but it will be secondary to the overall shape of what we are saying. If we then say “turn right”, we imply that the ‘turn’ will be more or less a right angle. Because this often implies more than one possibility, we mark it in one of two ways. We say “take the third on the right”, or we say “turn right at the Hog and Hound”. For redundancy, we are more likely to say “turn right at the Hog and Hound—I think it’s the third on the right”. When we say fork left, we do not indicate a number, because the direction “take the third fork on the left” is absurd without advice on how to deal with the two previous forks—unless, of course, they were particularly clear choices between a 45°

fork and a 'nearly linear' continuation. In all cases, the form our directions take reflects the underlying geometry of the situation.

One possible implication of this is that our knowledge of the urban grid as a whole may in some sense be geometrical. We are of course familiar with cases where this is clearly so: the regular orthogonal grid. Interestingly, the more regular the grid, the more likely it would be that our directions would rely on numbers rather than on landmarks. "Three blocks west, four blocks south" would be enough to identify a precise location in Phoenix, where landmarks are in any case few. We might call this type of strong geometrical knowledge 'Phoenix knowledge' in contrast to the weaker—but still marked—kind we seem to find in deformed grids. But knowledge of deformed grids seems still to retain some degree of geometry. For example, the classic test for candidate taxi drivers learning 'the knowledge' of London is 'Manor House to Gibson Square', a route which must cross the dominant grid diagonally and in a metrically efficient way. It is a Phoenix-type problem applied to a deformed grid situation. It is hard to see how it can be solved without knowledge of something like a geometrical approximation of the grid.

And what about the wry story told by an Irish comedian about asking the way in Dublin. Walking down Bolton Street he asks "How do I get to O'Connell street?". "Well now", comes the answer, "if you want to go there, I wouldn't start from here if I were you". This story is meant to illustrate the simplicity of locals. In fact it shows the complexity of urban knowledge. The direction giver thinks at once of Bolton Street, O'Connell Street, and a third hypothetically better starting place, among many other such possibilities, and simultaneously evaluates all these relations before giving advice that is good in all senses except one. Such knowledge clearly does not depend on landmarks, or make even the slightest use of them. This would only come in the next stage, of telling the inquirer how to get from somewhere else to where he or she wants to go. As it is, we may directly compare such 'Irish knowledge' of deformed grids with 'Phoenix knowledge' of regular grids, in that the role of the geometric pattern seems clear. This knowledge seems to be not only about the geometric construction of the grid, but also about its overall structure.

2.3 A global near-invariant: the ortho-radial grid?

If we then return to the 'objective' grid we find these suspicions are confirmed. It is not only at the level of the pervasive geometric construction that we find an unexpected degree of order in the axial map. It also appears at the global level. If we consider the whole visual pattern formed by the most integrated lines in the line graph analysis—the integration core—we find that in both cases it is composed of two dominant elements: on the one hand, the obtuse angle sequences form radial routes from more central to more peripheral areas, sometimes intersecting with each other, and sometimes not; on the other hand, a more grid-like central area, at once more orthogonal and (at least in part) smaller in block scale, to some part of which most radials connect. An integration core formed by these two elements, a central more orthogonal grid as the focus for centre to edge radials, is common to most cases. Studies of large and small urban systems, including very large systems such as Tokyo, Santiago, Athens, and Baltimore, suggest that, described in these broad terms, integration cores of this kind are very common indeed and may even be, at some level, a near-invariant in evolving urban systems, including in American cities (Major, 1998).

If this structure does turn out to be as common as it seems at present, then it will need to be described by a term which reflects its complex dual properties. Pro tem we would suggest it should be referred to as the 'ortho-radial' grid because, in seeking terms to describe its structure, we find ourselves invoking the two key rationalist ideas

that have always characterised the ideal forms of cities and which underlie most concepts of 'ordered' (as opposed to structured) urban systems: the orthogonal grid and the radial grid. This suggests an intriguing possibility: that these two 'ideal' notions of regular urban systems are not simply rational types formed by speculative thought but are found or inferred as deep structures in much less obviously ordered systems. Whatever the case, it is strange indeed that such a rationalist 'order' should be discovered through line graph analysis, which, as we have seen, takes no apparent account of geometrical variables. It is even stranger that a globally geometrical deep structure should arise as an emergent structure in organically evolving systems.

2.4 Line graphs and the essential urban dynamic

It is no less puzzling that many recent research results suggest that all this geometry may safely be ignored in investigating the relation between structure and function in urban space. It seems to be the mere existence of relations between elements, without considering such matters as angles or lengths, that captures dynamic processes by which evolving space structure influences movement, leading to effects on land-use patterns and, through multiplier effects back on movement, to further elaboration of space structure and eventually to the distribution of intense mixed-use central and subcentral areas and less intense areas with fewer uses which seems to characterise cities in general (Hillier, 1996a; 1996b).

Let us look carefully at the structure of this argument on the basis of a simple model. Consider the notional street grid shown over in figure 3(a), made up of a main horizontal street, a secondary vertical axis, and some interconnected back streets behind the blocks. Imagine the grid to be loaded everywhere with buildings that both generate and attract movement and then assume that movement tends to take the simplest available routes. It is clear that more routes will tend to pass through the main horizontal street than any other, with more passing through the central than the peripheral segments. It is equally obvious that very little 'all-to-all' movement will pass, say, through the horizontal street at the bottom right of the grid. Once we see this, we can move around the plan making reasonable intuitive guesses as to how much all-to-all movement is likely to pass through each street. In simple cases it is in effect easy to intuit that the way in which each line fits into the grid is an important determinant of how much movement each would get, other things being equal. It is no surprise, then, that such effects are also found in the larger and more complex kinds of grid that we find in real cities, though here the effects are harder to intuit. Even so, the example shows the proposition that the structure of the grid itself influences the flows of movement seems only to be expected.

The power of the grid structure to influence events can be made formally clearer by using the justified graph. In figures 3(b) and 3(c) we block one street in each [the main street in (b) and the bottom-right horizontal in (c)] and shade all other streets from dark to light according to their 'depth' from the blocked street. We then translate this, complete with shadings, into two j graphs, as in figures 3(d) and 3(e). The two j graphs immediately show not only that the shallower the graph is to the 'root' space of the graph, the more probable it is that a trip of n -line segments will include a segment of the root line in that sequence, and vice versa, but also that the shallower the j graph is to its root space, the more accessible that root space is as a destination from all other spaces, and vice versa. It is this combination of accessibility and potential permeability—that is, of to movement and through movement—that is captured by the j graph and which has proved so effective in analysing real systems of space and understanding how they work. It is also, of course, this that is expressed by the various measures of integration. The integration value reflects the shape of the justified graph from each space.

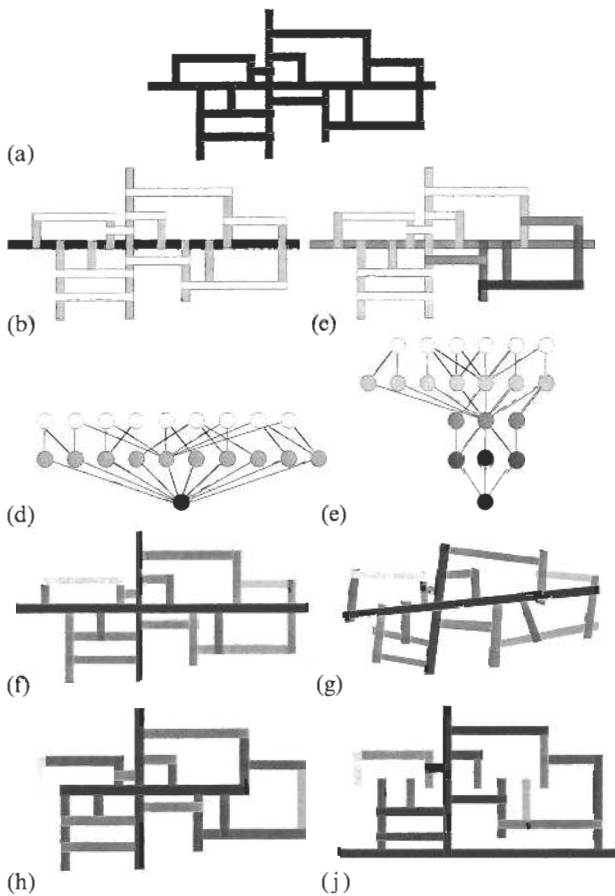

Figure 3. Notional street grid.

In shading our notional grid from dark to light in order to represent integration, as in figure 3(f), we are consciously representing the potential of the different grid elements for both accessibility and movement. Seen this way, the relation between grid structure and movement seems to be related entirely to syntax, as captured in the j graph, and has little to do with geometry. If, for example, the grid is deformed geometrically by changing the angles of incidence without changing any of the j graphs, as in figure 3(g), no difference is made to the analysis and it is difficult to see intuitively why it should make any difference at all to the movement pattern. If, however, we change the connections of lines, as in 3(h) and 3(j), then the whole distribution of integration changes.

Note that the influence of the grid on movement is subject to other conditions being satisfied: that the grid is more or less equally loaded in its different parts with buildings, that is, with origins and destinations, and that movement can be from all origins to all destinations. If the grid were differentially loaded, then we would expect this to bias the distribution of movement in the grid. The proper way to conceptualise the relation is to think of the grid structure itself as creating movement potentials which may or may not be actualised by the distribution of built forms and facilities in the grid. In practice, of course, grids are not equally loaded. They tend to concentrate different types of facilities in different parts to some degree. However, studies have shown that these biases are themselves influenced by the biases of grids, so the

relation between grid structure and movement is retained, though not in linear form (Hillier et al, 1993; Peponis et al, 1989; Read, 1999).

This is the root of what can be called the ‘essential urban dynamic’ by which grid structure, movement, land-use patterns, and densities become interrelated. The urban grid evolves and creates a pattern of movement potentials, and, to some degree, movement. Land uses which are movement dependent, such as retail, then select locations with high-movement potential, and others, such as residence, select locations with lower movement potential. Because movement-dependent land uses such as retail are essentially public spaces (in that they seek to attract everybody), this creates attractor effects in high-movement locations and, through this, multiplier effects on movement. These multiplier effects then feed back on other land-use patterns and create increased densities and mixed movement-dependent uses in high-movement locations. This dynamic feedback cycle initiated by the grid structure is a key to the organic growth of city patterns and to the sense that space, movement, land uses, and densities seem somehow to work together.

Because space syntax models only the topology of connections of spaces, we can illustratively model the land-use aspects of the process simply by adding land parcels representing, say, retail units, as spatial elements in the appropriate locations. As these will not normally allow through movement, we are in effect adding new, more or less accessible destinations in certain parts of the grid. The effects, as shown in figures 4(a)–4(d), will be to weight locations according to the number of elements added and to increase the integration value of these locations. Note that the addition of these weightings will create distortions in the whole pattern of the grid, making

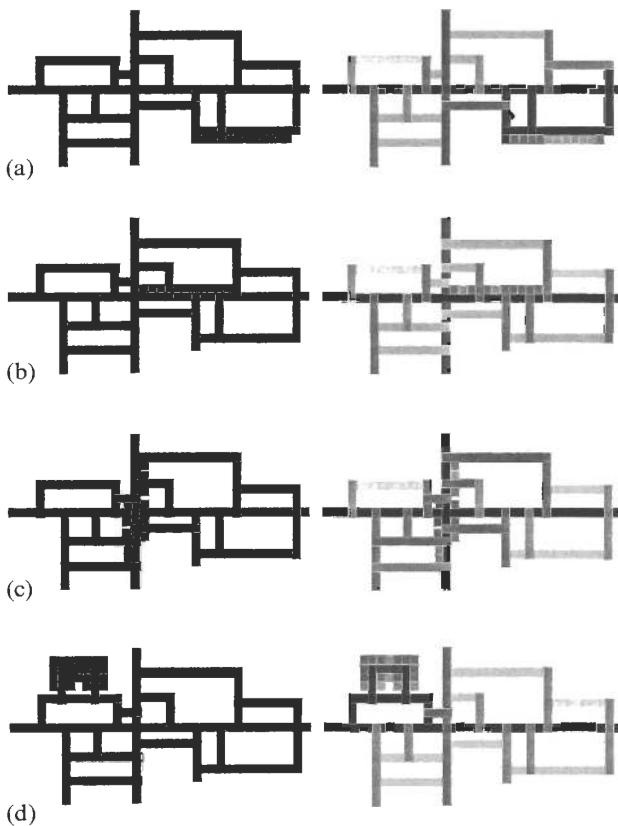

Figure 4. Notional street grid loaded with retail in different locations.

segregated locations more integrated [figures 4(a) and 4(d)] and integrated locations even more so [figures 4(b) and 4(c)]. These effects are not confined to the space to which the new elements are added, but also affect other streets in the vicinity, and through this increase the integration of this area at the expense of others. If the process prioritises the most integrated spaces, as it of course does in most organic towns, then this will make the line adjacent to the main integrators the most likely locations for the next stage of retail location, and retail will begin to develop either a clustering or a linear distribution, depending on the available structure of space. Further multiplier effects will follow, leading to more diversification of the grid, and so on.

Once this process is understood it becomes clear that an urban grid is not simply a spatial framework for human activity but a record of a historical process of evolution based on a simple dynamic. This is why a purely spatial analysis as in figure 1 gives a picture of the urban grid which is not only informative about movement but also about where the main shopping streets are (on, or adjacent to, key local and global integrators, depending on the historical operation of the attractor effect), and which parts of the grid will have greater concentrations of residence. The urban grid is not just a configurational shell for human activity. It is already alive with the history of human activity.

This is a very good result for space syntax theory but very bad for our hope of understanding the role of geometry in the spatial form of the city. We seem to have described the essential urban dynamic not only without reference to any of the geometric properties that we noted were pervasive in real cities, but we have gone some way to showing that the process seems independent of geometric form. Here we see the full scope of our problem: cities seem to be intuitable and constructible as geometries, but to work as graphs. Intuition appears to stand on one side, that of geometry, functionality on the other, that of graphs. Somewhere, somehow, there must be a link between the configurational, or graph, nature of the city and its geometric nature. Where might we look for it?

3 Problems with graphs

3.1 Graphs as knowables

One place where we are unlikely to find the answer is in the nature of graphs themselves. They are the least geometric of entities. Consider the set of small graphs shown in figure 5. Even though the ten graphs are very simple it is very far from obvious that the graphs are all the same. We are deceived by the geometric differences into thinking that the graphs are different. Even after it has been said that the graphs are all the same it is painfully difficult to try to trace through the relations in each graph to check whether or not this is the case. And these are very simple graphs.

One way to understand graphs is to analyse them 'syntactically'. In figure 6 two graphs are selected from figure 5 [(j) and (f)] and the total depth from each node calculated. We see that each node totals either 7 or 11. The upper graphs make it immediately clear why this is so. There are two linked 'central' nodes, and two dead-end nodes attached to each. We can then justify from each of these nodes and see that all of the graphs are in fact made up of these two *j* graphs and nothing else. Once we know this we can return to the graphs to check that they all have this structure. But even with this knowledge it is sometimes quite difficult to satisfy ourselves that the graphs really are the same. For example, graphs (g) and (h) in figure 5 clearly satisfy the requirement, but are they really the same graph. The difficulty is that we try to turn one into the other the wrong way, because we want to keep the two top or bottom nodes together as top or bottom nodes when what we have to do is to put one at the top and the other at the bottom. There can hardly be a simpler transformation than this, but even so we may find it initially awkward.

But this is in any case analytic understanding and does not give us the intuitive feel that we have grasped the structure of the graphs. This seems to depend on the presence

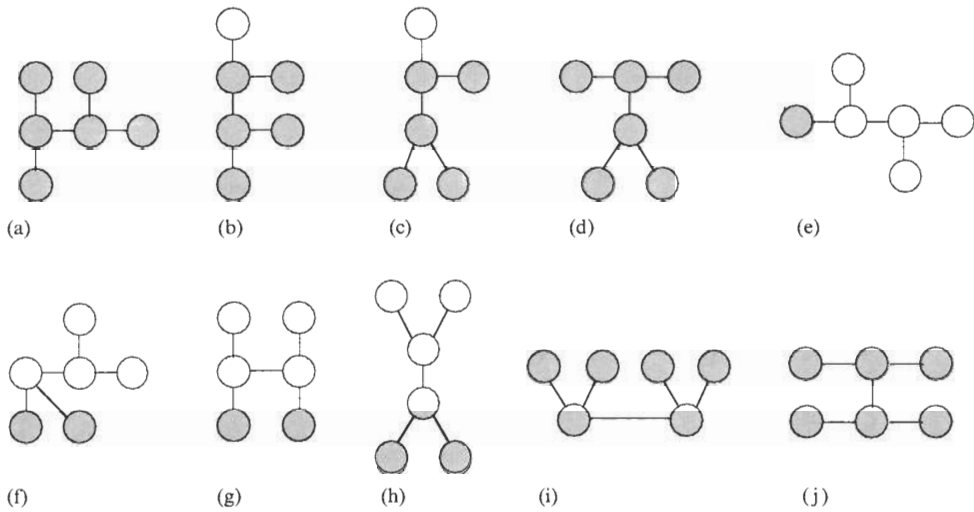

Figure 5. Ten identical graphs with different geometries.

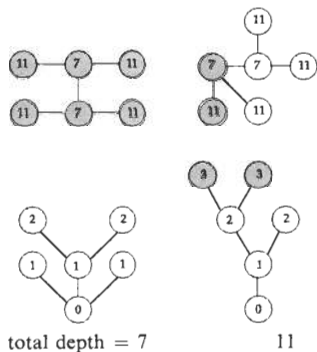

Figure 6. Total depth calculations for two cases selected from figure 5, and justification of the two j graphs within each.

of exactly what was missing from the graphs: a sense that the geometry expresses the graph relations in a consistent way. If we look at graphs (g) and (j) in figure 5, for example, both are constructed so that the same graph relation is expressed in the same geometric way. Because this is the case, we easily see the transformation from one into the other. We do not need to move nodes separately. We simply make a partial rotation of the whole graph. This can be explored further through figures 7(a) – 7(f), in which the sense that we understand the graph is first preserved under minor geometric perturbations (of the kind found in cities) and then progressively lost by the introduction of greater differences in the geometric interpretation of the graph, including one partial rotation. These examples suggest that it is internal geometric consistency that allows us to grasp the structure of the graph ‘all at once’ and to handle the whole object in comparisons. This is interesting because it is exactly the property we have called ‘order’. On reflection, we can see that the analysis of the graph gave us its structure, and the geometric consistency of the graph its order.

These are simple examples but they are powerful enough to suggest that our ability to grasp patterns can work in at least two ways. The first (perhaps we should put it last) is the level of analytic or step-by-step understanding, which is essentially linear (j graphs are essentially linearisations of the structure of the graph) and work on a step by step,

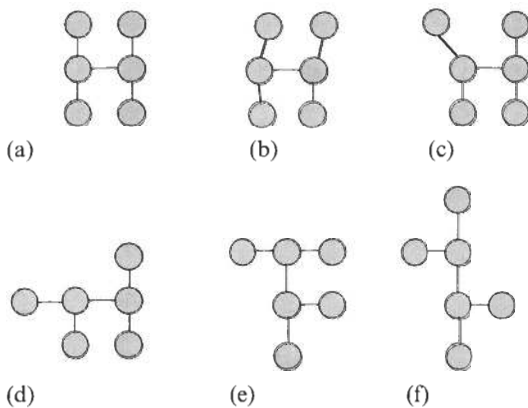

Figure 7. A series of geometric changes to a simple graph to show how the sense that we recognise it 'all at once' can be lost.

or procedural, basis, for example, by trying to transform one graph into another by shifting nodes one at a time. The second is syncretic, or all at once, understanding, which seems to depend less on a procedure and more on the ability to grasp a pattern instantly owing to the manifestly consistent ways in which it has been put together. It is only where the geometry gives an internally and externally consistent account of the graph that we have the sense of a syncretic understanding of the graph and can compare it confidently with others. The *j* graph is essentially linearised, and leads to analytic understanding, whereas the geometrised graph is, as it were, justified in two dimensions, so that it appears as an object with an internal order through which it immediately 'explains itself'. It is through this order that it is possible for us to read and understand it without reflection.

3.2 Graphs and functionality

The sense that we can 'know' a graph seems then to depend on giving it a geometric form which is entirely irrelevant to its nature as a graph and can even be misleading. The situation is hardly better if we consider graphs from the point of view of functionality. Much of what we have said about the essential dynamics of cities is based on the knowledge, derived from much research, that urban grids, seen as axial maps and analysed as graphs, behave and change in a systematic and predictable way. In fact, from a purely graph point of view, there are strong theoretical objections to this. Technically it seems that it is impossible to know the effects of a change in a graph on, say the crucial matter of the distribution of integration values for nodes, or even the gross morphology of the graph, without in some way or other checking the whole graph. From the point of view of syntax, graphs seem to be to all intents and purposes unpredictable. How then can they be the basis of systematic predictive knowledge of cities?

Consider figures 8(a)–8(g), for example. Figure 8(a) is an analysed graph with total depth values, in which the root node has three connections. We cut each connection in turn in 8(b), 8(c), and 8(d) and reanalyse to see how we have changed the structure of the graph. The total depth effect of each change is given below and the three changed graphs are justified in the bottom row to clarify the effects of the changes. In the first case, the elimination of the link turns the graph into a pure ring in which all values are the same. The second changes it to a smaller ring with one minimal 'tree' element. The third change brings about a much more radical transformation in the graph, turning it into a much more tree-like form with the ring reduced to a very local scale. We can easily see why each of these happens, and some things we can know from principle—for example,

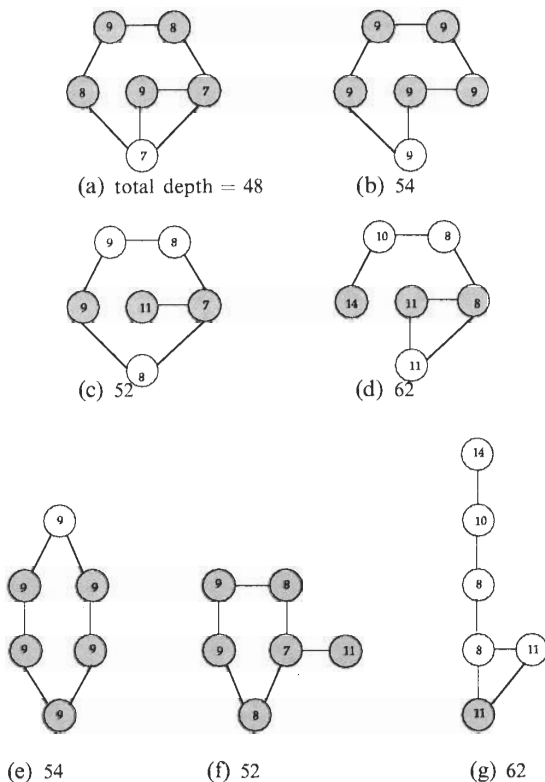

Figure 8. Series showing the different 'global' effects of three 'local' changes on the same graph.

that if we cut a ring we will not disconnect the graph and that we must create at least one tree element. But to know we are on a single ring and, if so, what kind of tree (shallow, as in the second case, or deep, as in the third) will be created requires us to check most, and in some cases all, of the other links in the graph. Even in as simple a case as this, to understand the effects of a change, whether minor and local as in the first two cases, or major and global as in the third case, we need knowledge of at least a whole complex of local relations and perhaps of the whole graph. Worse, what we need to know cannot be specified in advance. In complex graphs such as cities we will find that we need, in effect, to rejustify the graph from every node in turn, if we are to be sure of the effects of a change. To understand the effects of a change in a graph, then, we seem to require an empirical procedure rather than a theoretical model. How can this possibly be reconciled to the ideas that cities, when represented as graphs of their line structures, appear to behave in a regular and predictable way.

This is the nadir of our argument. Geometry seemed to be involved in how cities are constructed and how they are known but not in their functionality. Here graphs seemed paramount. But we have now seen that graphs cannot carry the weight that this placed on them. Left to their own devices, they seem too unknowable and too unpredictable to be the sources of urban order or structure. Because both geometry and graphs seem to have a clear role in urban spatial form, but neither can account for it on its own, it follows that we probably need to understand how they interact and perhaps how they are interdependent in creating urban order and structure. We can then begin by examining a theoretical case where they clearly interact: the 'theory of partitioning', set out in chapter 8 of *Space in the Machine* and developed for urban systems in chapter 9 (Hillier, 1996a).

4 How geometry and topology interact

4.1 The law of sufficient geometry

For those who have read these chapters, the theoretical unpredictability of graphs, as just reported, will come as a surprise. The theory of partitioning set out in chapter 8 shows how we can foresee from knowledge of a few principles the kind of ‘integration’ consequences that will follow from any partitioning (whether addition or removal) in terms of the ‘depth gain’ or ‘depth loss’ that it leads to in the system. The predictions are broad rather than precise, and calculation is needed to predict precise effects, but from principle we can usually know whether one partitioning ‘move’ will create more or less segregation than another. For example, in the simple cell complexes shown in figure 9, the segregative effect of a centrally placed block (a closed cell of four partitions, creating a void in the system) will be known from principle to be greater than for a peripherally placed one, and that of a linear block will be greater than for a square block of the same area. Exactly the contrary is the case if we introduce larger spaces instead of blocks: Centrality and linearity will integrate more, squareness and peripherality less. All these predictions, and the calculations that make them precise, pass through the intermediary of the graph.

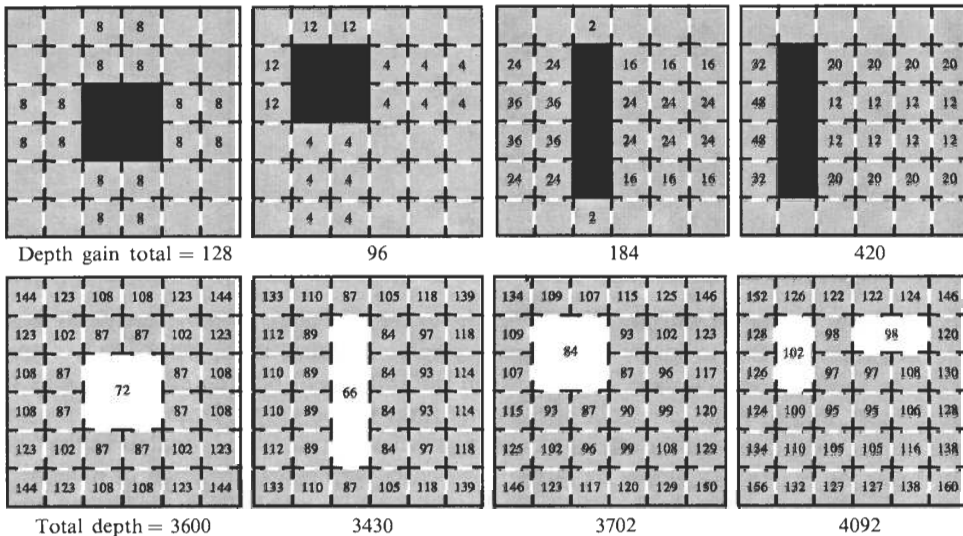

Figure 9. Series showing the effects of introducing blocks and larger spaces of different sizes and shapes on total depths from constituent cells of a uniform 6 × 6 cell complex. In the top layer, the figures in the cells show the depth gained by that cell from the introduction of the block, thus decreasing the ‘integration’ in the complex. The sum of the gains is given below, showing the effect on the whole complex. In the second layer, the figures show the total depth of each cell with the introduction of a larger space, with the resulting total depth of the complex given below. These show the gain in integration (depth loss) for the complex from the introduction of the different spaces.

Now according to what has just been said about graphs, none of this should be possible. But it works. Why? The answer lies in the hidden role of geometry. As figure 9 shows, the theory of partitioning was developed initially on the basis of spatial complexes with a regular geometric form. This was developed from the earlier idea of applying integration analysis to shapes by representing them as regular tessellations and then treating the tessellation as a graph. Because the unit of depth was a standard metric element, integration analysis measured, in effect, the modular distance from each tessellation element to all others. This gave rise to the notion of ‘universal

distance', meaning the distance from a location to all others, in contrast to distance in the normal sense of the distance between one location and another. By analysing shapes as tessellations, using the concept of universal distance, it was possible to show that certain geometrical properties of shapes, such as area–perimeter ratios, symmetries, degree of compactness, and so on, could be given a reasonable, and useful, interpretation in configurational analysis (Hillier, 1996a).

This geometrical framework is carried forward into the theory of partitioning. The partitioning model was developed on the basis of what was essentially a uniform tessellation of square spaces, amongst which partitions could be erected or removed. The concepts used in the theoretical model for predicting the effects of partitionings on spatial configuration are all essentially geometric: centrality, extension, contiguity, and linearity. Centrally placed partitions reduce integration more than peripherally placed ones; partitioning more extended lines reduces integration more than partitioning shorter lines; contiguous partitions reduce integration more than noncontiguous partitions; and linearly contiguous partitions reduce integration more than 'curled up' partitions; and vice versa in each case for the creation of continuous spaces.

The partitioning model, in effect, works not on the basis of graphs per se but on the basis of geometric shapes represented as graphs. The effect of this geometrization of the graph is to create a world in which graphs behave in a predictable and transparent way. The fundamental reason for this is that the measure of integration has been rendered metric: it measures not just the topological distance from each point to all others, but real distances, at least as measured in a rectilinear grid (rather than 'as the crow flies'). The pattern of topologically simplest paths in the graph, for example, has become isomorphic to the metrically shortest paths and because both are put into correspondence with geometric relations both are made accessible also to intuition and prediction. Geometry has been used to tame the wild disorderly world of graphs, to make them work lawfully and to access them to human intuition. In chapter 9 the same model was shown to apply to urban-type systems of block layouts by using the all-line map, that is, the line complex that results from drawing every straight line which is tangential to a pair of block vertices and subjecting the resulting—usually highly dense—line matrix to integration analysis. Such a system will follow the same principles as the partitioning theory and this is demonstrated through a series of case studies which involve changing the block structures of a notional urban system—for example, joining two blocks together, or removing them to create larger spaces. Figure 10 shows how it works. The all-line analysis generates a line for every pair of vertices that can see each other. This means that there will be more lines that intersect in the central areas and fewer near the edges. The same effects are also shown to occur in the deformed grids that characterise most urban systems.

There is then a profound sense in which geometry and graphs interact. By representing geometric shapes as systems of graphs through the intermediary of the regular tessellation, it can be shown how graphs can express the movement logic of the system. We can call it the law of sufficient geometry. In principle it seems that something similar seems to have happened in cities. Their spatial layouts seem to have acquired 'sufficient geometry' to make the graphs behave in a regular way. We have already noted that cities are nearly geometrical and that they are knowable and predictable through their geometric properties. We also know that, if graphs are to behave in a predictable and knowable way, there must be enough geometry in the system. We can be quite precise about this. There must be enough geometry to give an interpretable and consistent meaning to the geometric terms of the theoretical model: centrality, metricity, contiguity, and linearity. This can only be done in principle by a single

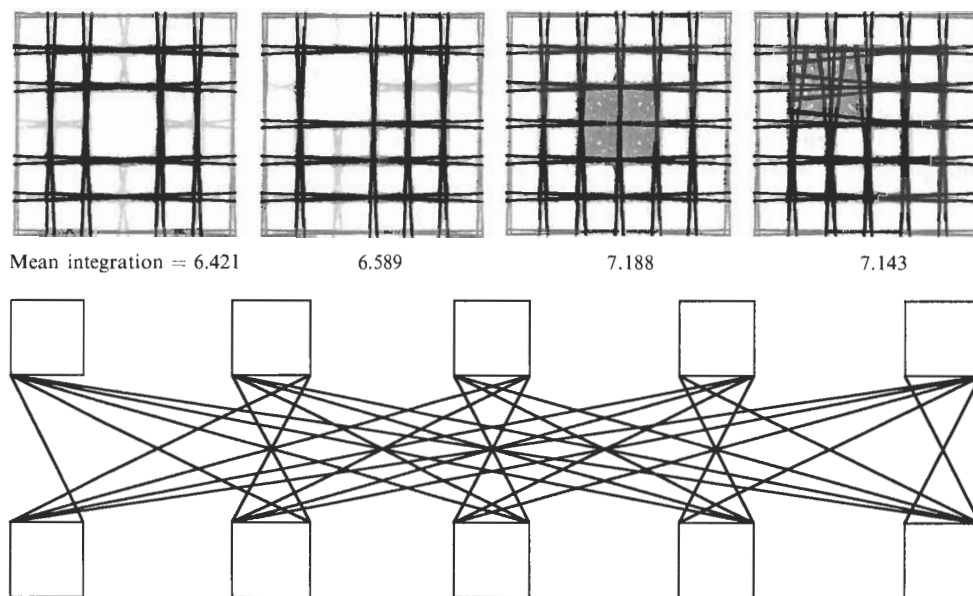

Figure 10. Series (upper layer) showing that the effects of introducing blocks and spaces with different shapes and location in a uniform grid analysed by the all-line method follows the same pattern as those shown in the cell complexes in figure 9. The lower figure magnifies parts of the all-line map to clarify its construction.

strategy: by bringing the geometric and metric properties of the system into a reasonable correspondence with the topology of relations described by the graph.

From their geometry and their functional behaviour it seems that something like this happens in cities. But to understand its exact nature we need to understand how it happens. Is there perhaps some process by which the city creates its own geometry as it grows and in this way ensures that its global configurational structures, as represented by its graphs, behave in a more or less knowable and predictable way. We have an important clue. If there is such a process, then it seems likely that it lies in the nature of movement.

4.2 Two reflections on movement

Or more precisely, in the geometry of movement. This reminds us of what was said in the opening sentences of this paper: that a key task of the researcher was to decide on a representation which might capture the functional logic of the system of interest. This reflects a key element in the metatheoretical foundation of space syntax: that space is not to be treated as a background either to objects or to human activities, but as an intrinsic aspect of both. Thus we converse in convex spaces, we see isovist fields, and we move in lines. One implication of this is that movement is not simply a functionality in the system, arising only as a consequence of the system. It also has its own natural geometry. The selecting of the line representation in the first place was intended to reflect the natural geometry of movement and so internalise it into the spatial representation. A line matrix thus becomes a configuration of possible movement.

At a very basic level, the line representation seems also to be called for by the most obvious single basic fact about the morphology of cities (and probably of most spatial systems as they grow large): the fundamental organisation of space is linear, in that buildings are arranged in paired rows to permit linear movement between them. Even in the most tortuous cul-de-sac sequences of spaces in, say, a traditional Islamic town,

the linear principle still holds. This is so much the basic principle of urban spatial organisation that it is difficult to see how it could have escaped the attention of generations of urban historians. It is even more difficult to see how some 20th century theorists could have contemplated the historical city and claimed that the enclosed space, such as the square or plaza, is the basic spatial element. Even at the most local level, settlement space is shaped linearly by buildings arranged in rows to facilitate movement. It is obvious that it should be so, and it is.

4.3 Linear and grid movement processes

It is not difficult to see how the evolution of settlement space then follows the logic of movement and reflects its geometry. The two types of consistency that we noted as pervasively urban systems—the obtuse angle radial sequences and the near right angle local complexes—are both products of the natural geometry of movement operating on the line combination processes by which the structure of settlement space evolves. All we need to consider is an old and familiar principle: the need to make movement as efficient as possible by minimising mean trip length.

But to understand the effect of this on the urban grid, and how it gives rise to the distinctive geometry of the city, we must consider two kinds of movement: movement from edge to centre (and back again), which is a matter of moving from a specific origin, say one of the peripheral entry points to the city, to a specific destination, and therefore requires an essentially linear form if trip lengths are to be minimised; and movement within urban areas, where the grid must respond not to the need for efficient movement from a specific origin to a specific destination, but to the need for efficient movement from all origins to all destinations. It is clear that the radial structure that we have noted as one of the geometric elements of the integration core of the city is generated by the first of these processes and in doing this it may well make use of or adapt preexisting paths between settlements. It is less clear that the ‘more or less orthogonal’ central grid is generated by the second. Nevertheless it is central to the argument here and must therefore be considered in great detail.

Suppose built forms are being generated randomly on a surface (which for the moment we will assume is isotropic). We can then conceive of each new building as both an attractor and a source of potential movement. Let us assume that there is some distance-decay function by which shorter journeys are more likely and longer journeys less likely. It is then possible that there is some local subset of built forms which are all likely to be destinations (and therefore sources) for each other, and others, more remote, some of which, but not all, will be destinations for this subset. It follows that there will always be a local subset of blocks where if the space organisation is to maximise trip efficiency then it must create the spatial pattern which minimises all-to-all mean trip length. We know already that this will be the system that maximises metric integration. In partitioning theory, all depth gain (which is the same as distance gain in mean trip length) results from making relations from origins to destinations nonlinear—in effect, causing deviations from ‘the shortest distance between two points’. We also know from partitioning theory (Hillier, 1996a) the principles for block placing to minimise non-linearity: block short lines rather than long; block peripherally rather than centrally; avoid contiguity because this will increase nonlinearity; and if you have contiguity, then ensure that the composite block is nonlinear.

It is not difficult to see that such a process of all-to-all distance minimisation will, by constantly placing new blocks either noncontiguously between existing blocks or on alignment with them, inevitably maximise the linearity of all spaces adjacent to blocks and this will lead to some approximation of the orthogonal grid. The word approximation is used advisedly because it is not the geometry of the grid that is optimal but its topology.

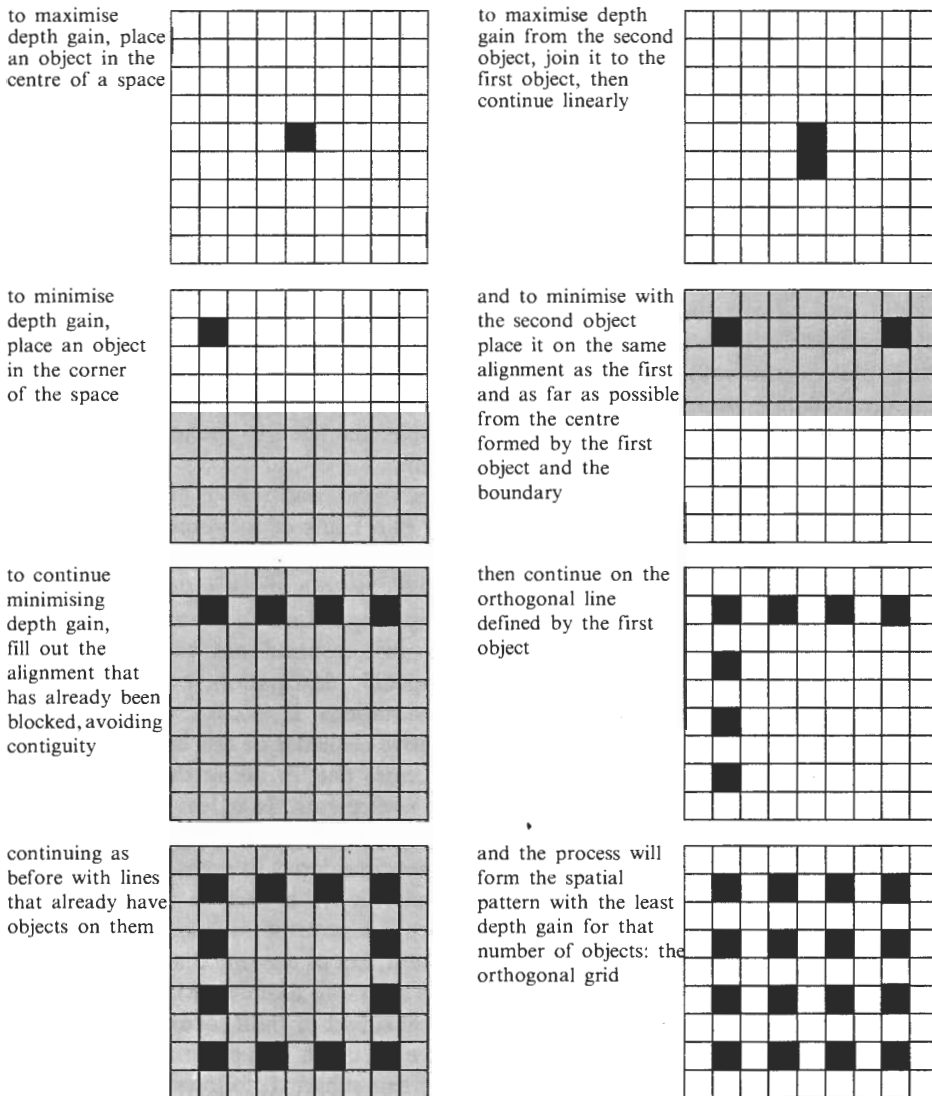

Figure 11. Series showing how the progressive placing of blocks within a uniform grid to minimise depth gain at each stage will construct a grid-like layout.

Deviation from strict rectilinearity will make no difference provided the connectivity topology of an orthogonal grid is realised. This process is illustrated notionally for a closed system in the sequence of captioned figures shown in figure 11. It shows clearly the primacy of line topology over geometry and perhaps shows it to be common sense. Suppose, for example, we retain the geometry of street alignments in Mayfair but fail to connect them to Oxford Street by building a wall. It is clear that the entire movement characteristics of the area will be transformed. It is of course the topology of connection that is critical, first to movement and from there to the dynamics of urban evolution.

It seems then that the two line processes generated by the logic of movement tend in themselves towards the kind of 'ortho-radial grid' that space syntax analysis identifies as a deep structure in cities of all kinds, including the largest, that is, a more or less orthogonal central grid area linked by radial alignment to more peripheral and

external locations. In other words, the logical outcome of trip minimisation, provided we specify the two kinds of movement, is exactly the generic geometric global structure that we tend to find in cities as their 'integration core'. As it is clearly the topology of connections created by the geometric processes of trip length minimisation that creates this global geometry, it is not surprising that the structure is revealed by topological analysis of the line structure. But surprising or not, we can say that, far from concealing the geometric structure of cities, it is the analysis of the line topology that brings it to light.

4.4 Exactly how geometry gets into the graph

In other words, the geometry gets into the graphs. Exactly how does it do so? We may begin by noting another common objection to the axial map as the basis of urban analysis: the nonuniformity of line elements. We have already seen that the topological property of connectivity is far more important than any geometric property in creating the potential of that line for carrying movement in the system. One of the most pervasive correlations found in axial maps of cities is that between the length of lines and their connectivity. Exactly what this correlation is depends on how it is measured and exactly what is measured. For example, the straight r^2 value for line length and connectivity for Tokyo is 0.78, and for London it is 0.64. For a sample of American cities, r^2 for mean length and connectivity is 0.773, and for a sample of European cities it is 0.637 (Major, 1998). However, if the log of both variables is taken so as to normalise the distributions and thus diminish the influence of the 'supergrid' lines, then the r^2 values for Tokyo and London become 0.65 and 0.61. In other cases, such as Amsterdam, the correlation is harder to assess owing to the effect of interventions such as the ring road, which, in the manner of ring roads, is a set of long integrated lines which at the same time are poorly connected. In general, however, in those parts of towns where the process of growth has been organic (grown street by street) or semiorganic (grown in lumps, as parts of the West End of London were), the degree of agreement between the length of lines and their connectivity is one of the foundations of order in the system.

Given this pervasive correlation it is clear that it is precisely the nonuniformity of the lines that allows the line length to be internalised into the graph as different degrees of connectivity. From the point of view of the whole system, the translation of the axial map into a line graph has the effect of translating each line not into a node per se, but into a distinct set of connectivities, and how this set of connectivities relates to all the other connectivities in the system is of course the critical property from the point of view of movement.

But it is not only the variable length of lines that is internalised into the structure of the graph. Angles of incidence are also approximated in the graph in the following way. If the connection from a line is close to a right-angle connection, and it is not a cul-de-sac (which will in fact immediately appear in the graph), then the likelihood is that it will link to at least one line that will link back to the original line, that is, form a local ring in the graph within one or two more connections. If the connection is an obtuse angle, and approximates a linear continuation, then the likelihood is that it will link to lines which then link to lines which have no other connection back to the original line within a reasonable number of steps. On the contrary it will find lines which are remote from other connections to the original line and this will be consistently true as obtuse angle connections continue into remote parts of the graph.

Both prime geometric variables, length of line and angle of incidence, thus appear as distinct pattern formers in the graph. In fact, characteristic axial configurations have very distinctive graphs. A useful place to start is the orthogonal grid which has the important graph property of being bipartite, meaning that the nodes can be divided into

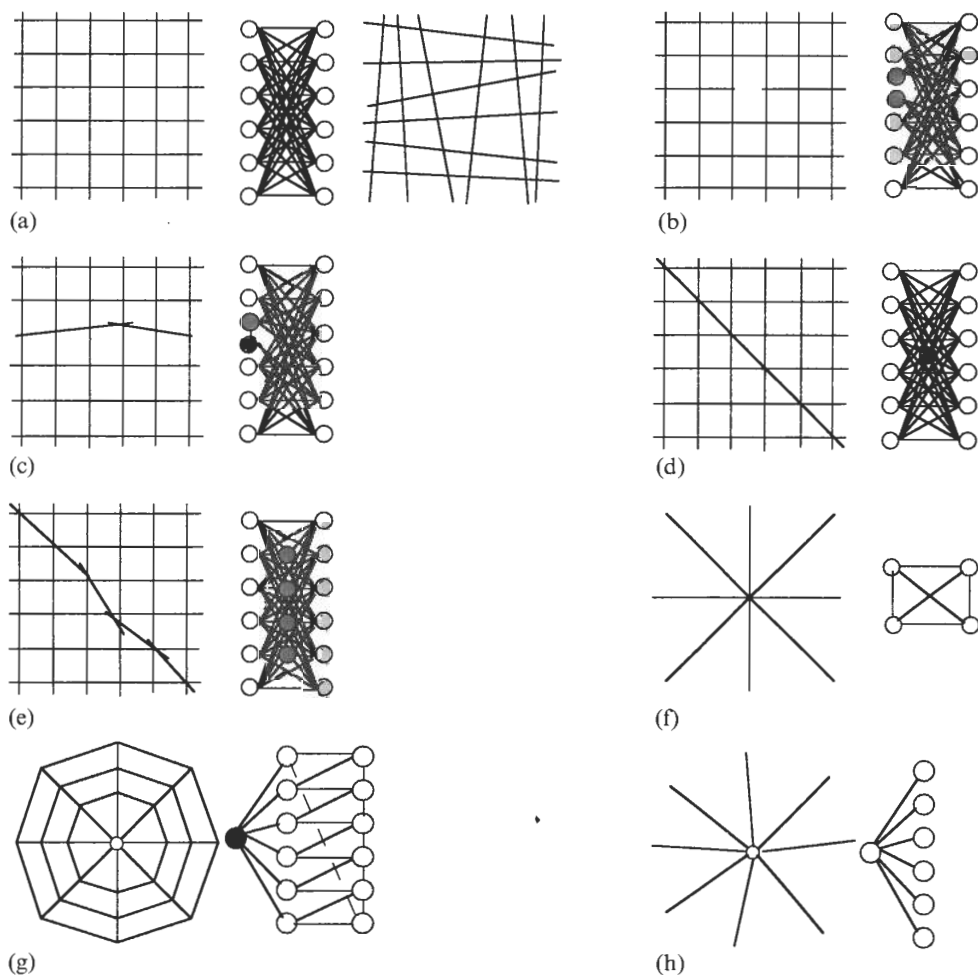

Figure 12. Graph representations of simple grid geometries.

two groups such that all connections are from one group to another, and none are within groups. Because these groups are symmetrical in the orthogonal grid it is useful to represent the graph as two vertical lines of nodes, with each node of each line connecting to all nodes in the other, but to none in its own, as shown in figure 12(a). The same graph will also apply to the nonorthogonal version on the right, but which still satisfies the topology of the orthogonal grid. The standard modifications of the orthogonal grid can then be represented simply within this convention. An 'interruption' in the grid, as in figure 12(b), shows as a split of one node in one of the lines into two, without a connection between them, with the connections to the other line split between the two nodes. A geometric 'deformation' of the grid, as in figure 12(c), shows as a split of one node into two, but this time with a connection between them, again with the links to the other line split appropriately. A diagonal line across the grid, as in figure 12(d), shows as a single node (located between the two vertical lines for graphic convenience) connection to each node in both lines. A 'wandering diagonal', as in figure 12(e), splits the diagonal node into a series with each connected to its neighbours and to each of the two lines of nodes as appropriate. A radial grid is one in which the two line groups of the graph connect to each other and become a clique (all connect to all others), and

each of the other group of 'lateral' lines connects to its lateral neighbours and to the neighbouring pair of radials, with a separate line of nodes needed for each circuit. At the theoretical limits, a set of lines which all link to each other (as in the radial group) are a clique, that is, a graph in which all nodes connect to all others, whereas a wandering radial will be a sequence of nodes in which each leads in either direction to exactly one other. These are the two integration limits for connected graphs. With a little skill we can learn to recognise elements of these patterns in the graph.

The line graph analysis does not then ignore the geometric properties of space: it internalises them into the graph. There is a pervasive geometric order in the axial maps of cities, constructed out of the lengths of lines and the angles of intersection, and it is exactly these properties that are in effect translated into the structure of the graph, that is, into its overall pattern of connectivities.

4.5 Internalising attraction

In internalising the geometry of the system into the graph it seems likely that the graph also internalises another key property of the system: the distribution of attraction, that is, the distribution of the potential destinations (and origins) for movement. Attraction has never been a key concept in the space syntax methods for predicting movement. In fact it has always been a quirk of the method for predicting movement that it seemed to do away with the need for laborious origin–destination analysis. Looking more closely, we see that origins and destinations are not ignored in the method: they are assumed to be more or less homogeneously distributed through the system, and only to the degree that this is so (with inhomogeneities due to the differential operation of the grid in different locations) will it be possible to predict movement from configuration alone.

This 'homogeneity assumption' is not laziness. There are good theoretical grounds for thinking it may be both justifiable and necessary. If we think of the built forms that construct the space of a settlement as attractors (and of course also as sources) of movement, then it is clear that the very logic of the evolving settlement system leads in the first place to the diffusion of this attraction throughout the system. The precondition of having a line in the axial map in a location is having built forms for it to reach. Two key points can be made about this 'attraction diffusion'. First, it will diffuse very much under the influence of the linear patterns that are created by the evolving movement logic of the system. Second, for simple geometrical reasons, attraction will, at least initially, be roughly proportional to the length of lines and therefore to the connectivity of the lines making up the system. In other words, to the degree that the metric properties of lines are reflected in the graph, then we should also find that the graph reflects the degree to which the diffused attraction of built forms is present on lines.

Where we then find abnormal local attraction, for example, owing to the presence of shops or higher building densities, we may expect it to be due to the multiplier effects and feedback processes identified in the 'essential urban dynamic' process. Because this process is itself set in motion by the effect of the grid configuration on movement in different locations, we would expect these attractor hot spots still to follow the logic of the grid [though in a nonlinear way (Hillier et al, 1993)] and thus to be captured in the line graph.

5.0 The logic of the nonlocal system

5.1 How graphs construct the nonlocal system

The graph can then be subject to analysis. The most important thing about a graph is that it is a diagram of pure relations. We may choose to weight nodes or links, but these are refinements, not part of the idea of a graph as a general model for relational structures of all kinds. Because it is a map of pure relations, in which elements (or nodes) have no

attributes apart from being connected to others, graph measures naturally measure extrinsic, or nonlocal, properties of elements. Even the simplest measure of a node, the connectivity (or degree) of the node, expresses not an intrinsic property of the element which it would retain if disjoint from the system, but an extrinsic property which it would lose entirely if it was disjoint from the system. There is no limit to the degree of extrinsicity or nonlocality that we can apply to measures. We can, for example, assign to each node its graph distance from all others. In this case we express as a property of the node its relative position in the system as a whole. This is of course the basis of the integration measures, and limiting the radius of the measure simply limits the number of topological steps away from a node in the graphs that we choose to count.

In other words, graphs, precisely because they ignore the attributes of elements and take into account only (and all) relations, are able to express extrinsic or nonlocal measures to the fullest extent. It is in the nature of a graph to give a picture of a node from the point of view of other nodes and, if we wish, from that of all other nodes. It is of course precisely this that is required in axial maps because urban spatial systems are themselves nonlocal systems. For example, as we have seen, the amount of movement that will pass through a line will be a function of its depth from all other lines and its position on all possible paths from all origins to all destinations, that is, its potential for to movement and through movement.

Nonlocal measures are therefore required if this logic is to be captured. This means that, to the degree that we assign intrinsic attributes to elements, the precision of this nonlocal description will be lost. However, assigning intrinsic attributes to elements such as nodes of the graph is unnecessary (and would be harmful) because we have already expressed all the key geometric attributes of elements (those through which the topology of the system is constructed) not as properties of the node but in terms of essential properties of the graph itself, that is, its relational structure.

The line graph is then far more subtle than appears at first sight. By internalising the geometric properties of elements into the structure of the graph itself, it permits a purely relational and highly nonlocal expression of the critical aspect of the axial map: its structure of connectivities. The line is in effect not reduced to a node but to a set of specific connectivities. In locating the line in the system as a whole, we are essentially locating that set of connectivities within the total set formed by the whole system. Connectivities, as we have seen, and their topological arrangement into a network by the geometry of the system, are by far the most important formal attributes of the system from the point of view of movement. And movement, as constructed by the line graph, drives the system.

There are then, it seems, solid theoretical grounds for the claim that line graphs succeed in representing the true geometry of cities. On reflection we can see that cities, as spatial systems, are of their very essence nonlocal. The key attributes of spatial elements are not intrinsic to the element but extrinsic and have to do with the position of the element in the system relative to all others. Changes in the surrounding system produce changes in the critical attributes of the element without changing its geometry. The nonlocality of the urban spatial system arises from the central role that movement, which is clearly nonlocal, plays in the shaping of space in the evolving urban system.

Both the line and the topology of the graph, it is argued, are critical to capturing this nonlocality. The line is the least local representation of space because it contains the least information about the local articulation of space and the most about remote connections, while topological measures are the least localised measures because they contain the least local information about the element and the most global information about the position of the element in the complex as a whole. The reason why the combination of line and graph 'works' in syntax analysis is because the two together

approximate the true nonlocal geometry of the urban system. Geometry may be the outward and visible form of urban order but line topology gives us its inner structure. This is why space syntax works—when it looks as though it shouldn't.

References

- Hanson J, 1989, "Order and structure in urban design; the plans for the rebuilding of London after the great Fire of 1666" *Ekistics* **56** (334–335) 22–42
- Hillier B, 1993, "Specifically architectural theory" *The Harvard Architectural Review* **9** 8–27
- Hillier B, 1996a *Space is the Machine* (Cambridge University Press, Cambridge)
- Hillier B, 1996b, "Cities and movement economies" *Urban Design International* **1** (1) 41–60
- Hillier B, Hanson J, 1984 *The Social Logic of Space* (Cambridge University Press, Cambridge)
- Hillier B, Hanson J, Leponis J, Hudson J, Burdett R, 1982, "Space syntax: a different urban perspective" *Architect's Journal* 30 November, pp 47–63
- Hillier B, Burdett R, Peponis J, Penn A, 1987, "Creating life: or does architecture determine anything?" *Architecture and Comportement: Architecture and Behaviour* **3** (3) 233–250
- Hillier B, Penn A, Hanson J, Grajewski T, Xu J, 1993, "Natural movement: configuration and attraction in urban pedestrian movement" *Environment and Planning B: Planning and Design* **20** 29–66
- Karimi K, 1998 *Continuity and Change in Old Cities* PhD thesis, Bartlett School of Graduate Studies, UCL, London
- Lynch K, 1960 *The Image of the City* (MIT Press, Cambridge, MA)
- Major M D, 1998, "Are American cities different: if so, how different are they?", working paper; copy available from M D Major, Space Syntax Laboratory, UCL, London
- Penn A, Hillier B, Banister D, Xu J, 1998, "Configurational modelling of urban movement networks" *Environment and Planning B: Planning and Design* **25** 59–84
- Peponis J, Hadjinikolaov E, Livieratos C, Fatouros D A, 1989, "The spatial core of urban culture" *Ekistics* **56** (334–335) 43–55
- Read S, 1999, "Space syntax and the Dutch city" *Environment and Planning B: Planning and Design* **26** 251–264
- Steadman J, 1983 *Architectural Morphology* (Pion, London)