

The Impact of Antenna Switching Time on Spatial Modulation

Ebrahim Soujeri, *Senior Member, IEEE*, and Georges Kaddoum, *Member, IEEE*

Abstract—Spatial Modulation (SM) is an emerging technology that reduces hardware complexity, power consumption, inter-channel interference and antenna synchronization problems of multiple-input multiple-output (MIMO) communications. However, SM depends on continuous antenna transitions that rely on RF antenna switches which consume considerable time. Because of this, the data rates of SM schemes face a cap and are bound to certain limitations and the effective SM transmission is much less than the nominal value. In this letter, we study the impact of switching time on SM and we develop expressions for the effective transmission rate, effective capacity and spectral efficiency. An upper bound on the switching time is derived such that SM sustains capacity superiority in comparison with SIMO systems.

Index Terms—Spatial modulation, switching time, effective capacity, effective data rate, spectral efficiency.

I. INTRODUCTION

SPATIAL modulation (SM) is an antenna-transition-based scheme that has been developed in the last decade [1], [2] with unique features. Data rate increment achieved via the utilisation of the index of actively transmitting antenna is the core of this modulation scheme. Other benefits of using such modulation schemes comprise improved capacity, spectral and energy efficiency, the reduction to a single RF chain and the removal of inter-channel interference and inter-antenna synchronization requirements. Despite the existence of some drawbacks in this system like the absolute reliance of its performance on channel state information (CSI), i.e. being sensitive to channel correlation and erroneous CSI [3], it has been the focus of many research studies in the last decade. While bit error rate (BER) performance evaluation has received most attention, very little has been discussed about antenna transitions that constitute a critical property of SM systems. In fact, a study of MIMO antennas for mobile handsets has been carried out in [4] where the isolation properties of decoupling mechanism of certain antennas are discussed. In this regard, parasitic antennas which rely on Micro Electro Mechanical Systems (MEMS) technology for RF applications are already being used in handheld mobile devices. Further, the switching time in MEMS technology is known to be in the range of $2 - 50 \mu\text{s}$ which renders it inefficient for today's high-speed applications. Indeed, since SM may require a transition (switching) to happen for the

transmission of each individual symbol to materialize, it is clear that switching times in antenna controllers must be significantly smaller than the symbol period. This requirement puts the option of MEMS-based switching technology off the table. According to [5], parasitic antenna arrays for MIMO applications using semiconductor diodes faster than $0.1 \mu\text{s}$ (100 ns) are available. While in [6], the effects of antenna switching on band-limited spatial modulation is investigated, where the employment of an SM-specific practical time-limited shaping filter is taken into account and the use of multiple RF chains is considered to transmit the side-lobes of band-limited pulses, in many recent works, i.e. [7] and [8], this issue has never been tackled or debated. This work is the first in this regard to shed the light on the feasibility of implementation of SM technology under the speed constraints of currently existing antenna switching technologies.

Contributions: Encouraged by the fact that RF antenna switches constitute an important part of the RF front end [9] utilised in SM systems and we admit that these RF switches are neither cost-free nor steeply climbing (in zero-time) and require certain advanced technologies to perform, i.e. acknowledging that switching time intervals introduce systematic transmission gaps in SM systems which overshadow its overall communication performance. In this letter, we calculate the effective data rate, the effective capacity and the spectral efficiency of SM systems for the first time under this practical constraint. In fact, we explore the speed limitations of industrial RF switches to analyse the SM system and to develop expressions for the effective data rate, effective capacity and spectral efficiency. We also identify the upper bound on the switching time interval such that the capacity superiority of SM with respect to single antenna transmission systems is sustained.

II. SYSTEM MODEL

In SM, bits to be transmitted are grouped into $m+n_t$ blocks, where the information is transmitted via $N_t = 2^{n_t}$ number of antennas, where each antenna is loaded with a symbol from the constellation pool that has a size of 2^m [1], [2]. We add that the SM scheme would be equipped with an RF switch at the transmitter in the fashion shown in Fig. 1. Further details on RF switching can be found in [10] and in [11], and are omitted from this letter for lack of space. Literally, the fastest RF switch fabricated today has a switching time of 20 ns.

III. ANALYTICAL VIEW

In an RF front end, we view the switching time as the time needed for the RF switch to forward an incoming signal to

E. Soujeri and G. Kaddoum are with the University of Québec, ÉTS, LaCIME Laboratory, 1100 Notre-Dame Ouest, H3C 1K3, Montreal, Canada (e-mail: esoujeri@ieee.org). E. Soujeri is also affiliated to the Dept. of Electrical and Electronics Engineering, European University of Lefke, TR North Cyprus. This work has been supported by the NSERC discovery grant 435243 – 2013.

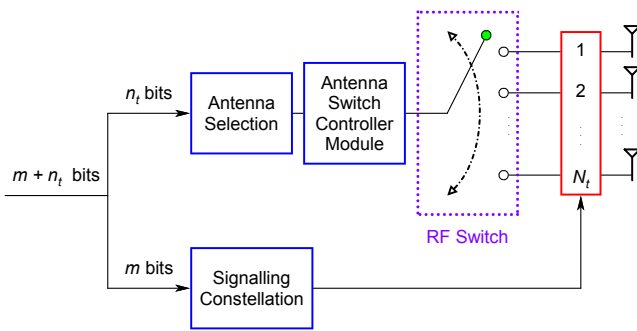

Fig. 1: Block diagram of the SM transmitter.

an antenna on one of its branches. In an SM system with N_t antennas at the transmitter, the process of choosing an antenna at every transmission period is a mutually exclusive event that follows a discrete uniform distribution. Since the antenna index is chosen from a constellation, a given antenna, i.e. the k^{th} antenna is chosen with a probability of

$$P_s = \Pr(a = a_k) = 1/N_t, \quad (1)$$

where P_s denotes the probability that the transmission stays on the k^{th} antenna to transmit the next symbol, i.e. no switching happens. Likewise, the probability of switching to another antenna P_{sw} to transmit the next symbol would become

$$P_{sw} = 1 - P_s = 1 - 1/N_t. \quad (2)$$

In fact, (2) shows the probability of hopping or jumping to another antenna in a set of N_t antennas. Considering these two probabilities and the fact that if a switching occurs then the symbol duration will be the switching time plus the SM symbol time, i.e. $T_{sw} + T_s$, we may now discuss the effective SM symbol duration T_{av} which we define as

$$T_{av} \equiv P_s \cdot \underbrace{T_s}_{\text{(duration if not switching)}} + P_{sw} \cdot \underbrace{(T_s + T_{sw})}_{\text{(duration if switching)}} \quad (3)$$

which, after substituting (1) and (2) into (3), may expand as

$$T_{av} = \frac{(T_s + T_{sw})N_t - T_{sw}}{N_t}. \quad (4)$$

As observed in (4), the effective SM symbol duration depends on the number of antennas involved in transmission and on the *switching* time in relationship with the RF switch. On the one hand, it is clearly noticed that T_{av} reduces to $T_{av} = T_s$ in the hypothetical case of $T_{sw} = 0$. This hypothesis is, however, unachievable in practical systems. On the other hand, a practical implementation of some SM receivers may require the insertion of a vacant pause of duration T_{sw} whether or not switching takes place, to maintain synchronization and to avoid receiver oversampling of the received signals which may complicate the reception process. Hence, this hardware configuration can be analysed with the given analytical models by letting $P_s = 0$ and $P_{sw} = 1$ in (3), or equivalently, by having N_t very large in (4). Moreover, the performance of this SM system configuration is discussed in the discussion and simulation results section (section IV). Considering (4), the effective data rate R_{ef} of SM will be expressed in symbols per second (sps) as

$$R_{ef} = 1/T_{av} = \frac{N_t}{(T_s + T_{sw})N_t - T_{sw}} \text{ sps.} \quad (5)$$

A. Effective SM Capacity

We use the conventional information theory approach [12] to calculate the capacity of SM systems as

$$C_{SM} = (m + n_t) \left(1 + p_e \log_2(p_e) + p_c \log_2(p_c) \right) \text{ bpcu} \quad (6)$$

where p_e represents the probability of error of SM detection in fading channels, $p_c = 1 - p_e$ is the probability of correct detection and $m + n_t$ represents the total number of bits conveyed by the SM system, where m bits choose a constellation symbol and n_t bits choose an antenna for transmission. Furthermore, the capacity of SM is not calculated the way it is done for MIMO communications, this is because the calculation of MIMO capacity C_{MIMO} does not apply [12]. In fact, the antenna number in SM represents added information and the antenna pattern is considered as spatial constellation, not as an information source as in MIMO. Moreover, other forms of determining the SM capacity based on mutual information may also be found in [13]. Note that p_e is calculated in a fading channel environment since SM is not defined for AWGN channels in which it is impossible to detect the antenna indices which require the uniqueness of channel coefficients. Ideally, the achievable SM data rate R_s would be

$$R_s \leq C_{SM}, \quad (7)$$

where $R_s = 1/T_s$ and in practical situations where $T_{sw} \neq 0$, the effective SM data rate would be bounded as

$$R_{ef} \leq C_{ef}, \quad (8)$$

where C_{ef} is the effective capacity. Dividing (8) by (7) and considering the equality to compute an upper bound, we may now without loss of generality express C_{ef} in terms of C_{SM} in combination with (5) and (6) as

$$\begin{aligned} C_{ef} &= R_{ef}/R_s \cdot C_{SM} \\ &= \frac{N_t T_s}{(T_s + T_{sw})N_t - T_{sw}} \cdot C_{SM} \\ &= \frac{1}{1 + (1 - 1/N_t)\beta} \cdot C_{SM} \end{aligned} \quad (9)$$

where $\beta = T_{sw}/T_s$ in (9) plays a fundamental role in determining the effective capacity for a given SM configuration with N_t transmitting antennas. It is also crucial to note that

$$\lim_{\beta \rightarrow 0} C_{ef} = C_{SM}. \quad (10)$$

B. Restrictions on β

Using (9) along with [3], [14] we may state the following order: $C_{SIMO} \leq C_{ef} \leq C_{SM} \leq C_{MIMO}$, where C_{SIMO} is the capacity of SIMO systems. Note that if β grows then C_{ef} will drop even below C_{SIMO} and as a result, the capacity gain achieved by SM will be lost which renders this modulation scheme useless and obsolete. Therefore, it is crucial to find a threshold value β_{th} that will keep C_{ef} above C_{SIMO} such that investing in SM systems would be feasible from the capacity point of view. In order to find the threshold value

β_{th} that achieves this, we proceed following the requirement that $C_{SIMO} \leq C_{ef}$ where for N_t degrees of freedom, C_{SIMO} is calculated as described by (8.33) in [14] and C_{ef} is calculated according to (6) and (9). Noting the above, we pursue as

$$\frac{1}{1 + (1 - 1/N_t)\beta} \cdot C_{SM} \geq C_{SIMO} \quad (11)$$

which results in the following β values

$$\beta \leq \beta_{th} = \frac{N_t}{N_t - 1} \left(\frac{C_{SM} - C_{SIMO}}{C_{SIMO}} \right) \quad (12)$$

and this forces T_{sw} to remain capped in the range

$$T_{sw} \leq \frac{T_s N_t}{N_t - 1} \left(\frac{C_{SM} - C_{SIMO}}{C_{SIMO}} \right). \quad (13)$$

Note that (13) above is extremely important and shows a critical relationship between the switching time T_{sw} and the symbol period T_s if SM capacity achievement is to be retained. As a matter of fact, (13) introduces an upper bound on the switching time T_{sw} in terms of the SM symbol duration T_s such that the capacity achievement of SM, as a system that uses multiple antennas to enhance capacity, in comparison to single-antenna systems is to preserve its superiority. Moreover, the upper bound on the switching time for a given scenario involves the calculation of C_{SM} and C_{SIMO} as described earlier under similar channel conditions.

C. Spectral Efficiency

For an SM symbol with duration T_s , the raised cosine filter occupies a bandwidth B_{SM} for each pulse [6] that is given by

$$B_{SM} = (1 + \alpha)/T_s, \quad (14)$$

where $0 \leq \alpha \leq 1$. Keeping this in mind, we observe that switching introduces continuous vacant (empty) pauses in the time domain that interrupt and slow down the effective data rate. Note that while the SM system occupies a bandwidth B_{SM} as indicated in (14) its effective data rate reduces as given in (5). Inspired by [15], we calculate the spectral efficiency η of our system as the effective data rate divided by the bandwidth as

$$\begin{aligned} \eta(\beta) &\equiv \frac{R_{ef}}{B_{SM}} = \frac{N_t}{(T_s + T_{sw})N_t - T_{sw}} \left(\frac{T_s}{1 + \alpha} \right) \\ &= \frac{N_t}{N_t + \beta(N_t - 1)} \left(\frac{1}{1 + \alpha} \right). \end{aligned} \quad (15)$$

The spectral efficiency described in (15) is expected to degrade and vanish for large values of β since

$$\lim_{\beta \rightarrow \infty} \eta = 0, \quad (16)$$

and to become inversely proportional to β for large N_t as

$$\eta_{min} = \lim_{N_t \rightarrow \infty} \eta = \frac{1}{(1 + \beta)(1 + \alpha)}. \quad (17)$$

Furthermore, the maximum achievable spectral efficiency is independent of N_t and only occurs in the ideal case, i.e.

$$\eta_{max} = \eta|_{\beta=0} = \frac{1}{(1 + \alpha)}, \quad (18)$$

however, the spectral efficiency can never reach unity in practical systems because neither the switching time T_{sw} nor the roll-off factor α are zero.

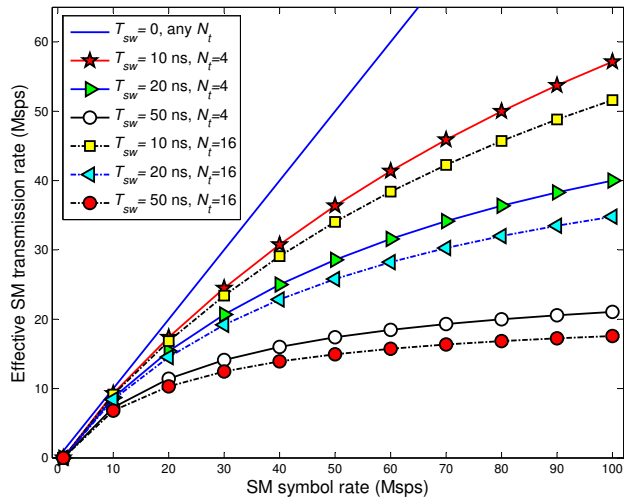

Fig. 2: The effective SM data rate versus SM symbol rate.

IV. DISCUSSIONS AND SIMULATION RESULTS

Switching time has an undeniable direct influence on the achievable data rate, spectral efficiency and capacity. The results obtained in this work confirm that industrial RF switches which are known to have a quantified and limited transition speed, impose an upper bound on the achievable data rate. In other words, moving to higher data rates will only be possible with advancements in RF switching technology, specifically from the *switching speed* point of view. Our results concerning the effects of switching time on these parameters will be presented in the remaining part of this letter. Fig. 2 shows the effective SM transmission rate in mega symbols per second (Mpsps) in realistic scenarios at various RF switching speeds for $N_t = 4$ and 16 antennas. Judged by the wide gap in the effective SM data rates for $T_{sw} = 0$ and $T_{sw} = 20$ ns (the fastest RF switch available today), the important message that is conveyed by Fig. 2 is that ignoring T_{sw} leads to unrealistic transmission rate expectations. It is also observed that as N_t increases the effective data rate decreases, since the probability of hopping to a different transmitting antenna at every transmission instant rises. In Fig. 3, the capacities of MIMO, SIMO and SM are shown where the capacities of MIMO and SIMO are reproduced using the formulations given in [14] at SNR= 0 dB in a fading channel. The capacity of SM is calculated according to (6) where p_e is based on the optimum maximum likelihood (ML) detection outcome at the same SNR with a modulation order of $M = 8$, i.e. $m = 3$. Note that since N_t has to be a power of 2 in SM systems, we have compared the capacity of SM with the rival systems at these values of N_t only. Moreover, the relationship $N_t = N_r$ is preserved in order to have a fair comparison between SM and MIMO systems given in [14]. Table I shows capacity and switching parameters versus antenna configurations. As seen in Fig. 3, longer SM switching times cause C_{ef} to reduce to the capacity of single antenna transmission schemes C_{SIMO} . As a result, the capacity gain achieved by spatial modulation is lost and, effectively, using SM to enhance capacity becomes useless and obsolete when β exceeds the threshold β_{th} . Fig. 3 clearly shows that SM achieves a higher capacity in comparison to SIMO as long

| $N_r = N_t$ | 2 | 4 | 8 | 16 |
|--------------------------------|--------------|--------------|--------------|----------------|
| n_t | 1 | 2 | 3 | 4 |
| p_e | 0.136 | 0.080 | 0.031 | 0.006 |
| SM & MIMO ($N_t \times N_r$) | 2×2 | 4×4 | 8×8 | 16×16 |
| SIMO ($1 \times N_r$) | 1×2 | 1×4 | 1×8 | 1×16 |
| β_{th} based on (12) | 0.3634 | 0.4693 | 0.6281 | 0.6783 |

TABLE I: Capacity and switching parameters vs. antenna setup.

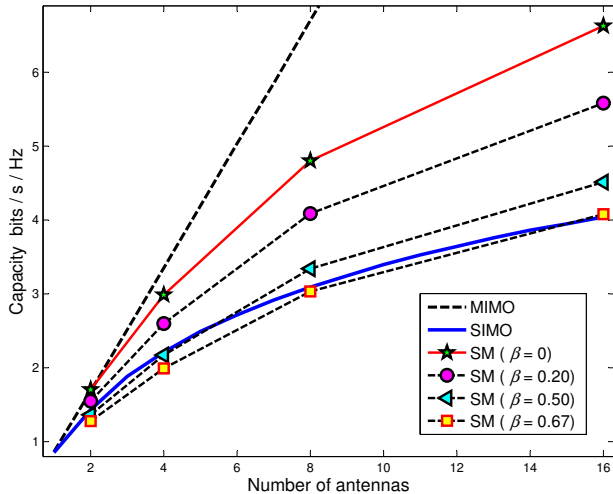

Fig. 3: Capacities of MIMO, SM and SIMO systems.

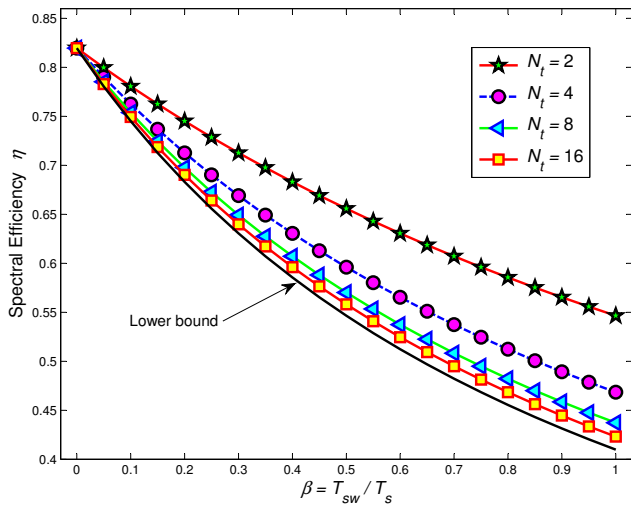

Fig. 4: SM Spectral efficiency η versus β for various values of N_t .

as β does not exceed β_{th} , which confirms our analytical results with respect to the threshold value β_{th} . In summary, growing β values push the C_{ef} curves down towards C_{SIMO} , which is in line with our analysis. Finally, the spectral efficiency η vs. β calculated according to (15) is shown in Fig. 4 for various values of N_t and for a roll-off factor $\alpha = 0.22$ which is recently adopted in long-term evolution (LTE) filters [16]. The asymptotic lower bound in Fig. 4 concerns the insertion of an empty slot of duration T_{sw} at every transmission to relax receiver synchronization, whether antennas switch or not, which also corresponds to very large N_t , as remarked in (4).

V. CONCLUSIONS

In this work, we consider the effect of switching time which is an inherent property of RF industrial switches on SM

systems. Switching time being in the order of nanoseconds naturally influences the transmission rate of SM systems because of introducing systematic transmission pauses. Given the speed limitation of practical RF switches in performing transitions, antenna transition-based technologies like SM schemes are capped in terms of data rate performance. In fact, the effective data rate of SM will remain hostage to developments in industrial RF switches. This brings restrictions to the implementation and operation issues when extremely high data rates become a necessity. Since the technology marches towards emerging systems where bandwidth efficiency and data rate are both essential requirements, it is necessary to develop new SM techniques based on minimum transition of antennas, or on the transition of a group of antennas at a time rather than schemes that require a transition at every transmission instant. It is shown by the assemblage of our results that the switching time T_{sw} which is a requirement for transitions between antennas to happen, dictates restrictions on data rate, capacity and spectral efficiency of SM systems.

REFERENCES

- [1] R. Y. Mesleh, H. Haas, S. Sinanovic, C. W. Ahn, and S. Yun, "Spatial modulation," *IEEE Trans. Veh. Technol.*, vol. 57, no. 4, pp. 2228–2241, 2008.
- [2] J. Jeganathan, A. Ghrayeb, and L. Szczecinski, "Spatial modulation: optimal detection and performance analysis," *IEEE Commun. Lett.*, vol. 12, no. 8, pp. 545–547, 2008.
- [3] E. Soujeri and G. Kaddoum, "Performance of spatial modulation over channel imperfections," in *15th IEEE International Conference on Ubiquitous Wireless Broadband (ICUWB2015)*. IEEE, 2015, pp. 1–5.
- [4] S. Shoaib, I. Shoaib, N. Shoaib, X. Chen, and C. G. Parini, "MIMO antennas for mobile handsets," *IEEE Antennas Wireless Propag. Lett.*, vol. 14, pp. 799–802, 2015.
- [5] A. Kalis, A. G. Kanatas, and C. B. Papadias, *Parasitic Antenna Arrays for Wireless MIMO Systems*. Springer, 2014.
- [6] K. Ishibashi and S. Sugiura, "Effects of antenna switching on band-limited spatial modulation," *IEEE Commun. Lett.*, vol. 3, no. 4, pp. 345–348, 2014.
- [7] N. Serafimovski, A. Younis, R. Mesleh, P. Chambers, M. Di Renzo, C.-X. Wang, P. M. Grant, M. A. Beach, and H. Haas, "Practical implementation of spatial modulation," *IEEE Trans. Veh. Technol.*, vol. 62, no. 9, pp. 4511–4523, 2013.
- [8] M. Di Renzo, H. Haas, A. Ghrayeb, S. Sugiura, and L. Hanzo, "Spatial modulation for generalized MIMO: Challenges, opportunities, and implementation," *Proc. of the IEEE*, vol. 102, no. 1, pp. 56–103, 2014.
- [9] C. Bowick, *RF circuit design*. Newnes, 2011.
- [10] *RF Switch Guide; Making your switch selection fast and easy*, California Eastern Laboratories, 2 2015, cel.
- [11] *Single-Pole Double-Throw (SPDT) switch*, NXP Semiconductors, 7 2014, rev. 3.
- [12] F. A. Prisecaru, "Mutual information and capacity of spatial modulation systems," Jacobs University, Bremen, Germany, Tech. Rep., 2010.
- [13] Z. An, J. Wang, J. Wang, S. Huang, and J. Song, "Mutual information analysis on spatial modulation multiple antenna system," *IEEE Trans. on Commun.*, vol. 63, no. 3, pp. 826–843, 2015.
- [14] D. Tse and P. Viswanath, *Fundamentals of wireless communication*. Cambridge university press, 2005.
- [15] W.-G. Chung, E. Lim, J.-G. Yook, and H.-K. Park, "Calculation of spectral efficiency for estimating spectrum requirements of IMT-advanced in Korean mobile communication environments," *ETRI journal*, vol. 29, no. 2, pp. 153–161, 2007.
- [16] E. Dahlman, S. Parkvall, and J. Skold, *4G: LTE/LTE-Advanced for Mobile Broadband, 2nd Ed.* Academic press, 2013.