

2000

# THE IMPACT OF CULTURE ON FEEDBACK-SEEKING BEHAVIOR: AN INTEGRATED MODEL AND PROPOSITIONS

Mary Frances Sully de Luque  
*University of Nebraska - Lincoln*

Steven M. Sommer  
*University of Nebraska - Lincoln*

Follow this and additional works at: <https://digitalcommons.unl.edu/managementfacpub>



Part of the [Business Administration, Management, and Operations Commons](#), [Management Sciences and Quantitative Methods Commons](#), and the [Strategic Management Policy Commons](#)

---

Sully de Luque, Mary Frances and Sommer, Steven M., "THE IMPACT OF CULTURE ON FEEDBACK-SEEKING BEHAVIOR: AN INTEGRATED MODEL AND PROPOSITIONS" (2000). *Management Department Faculty Publications*. 192.  
<https://digitalcommons.unl.edu/managementfacpub/192>

This Article is brought to you for free and open access by the Management Department at DigitalCommons@University of Nebraska - Lincoln. It has been accepted for inclusion in Management Department Faculty Publications by an authorized administrator of DigitalCommons@University of Nebraska - Lincoln.

## THE IMPACT OF CULTURE ON FEEDBACK-SEEKING BEHAVIOR: AN INTEGRATED MODEL AND PROPOSITIONS

MARY F. SULLY DE LUQUE  
University of Pennsylvania

STEVEN M. SOMMER  
University of Nebraska

**In recent research scholars have addressed the issue of an individual's behavior in feedback-seeking activity and, except in scant studies, have virtually ignored the role of culture in this area. In this article we explore four cultural syndromes, based on past research, to form a cross-cultural model of feedback-seeking behavior. We advance propositions for the study of culture as a moderator to feedback-seeking behavior.**

Feedback is a topic of significant research attention in the social sciences at the cognitive and organizational level (Ilgen, Fisher, & Taylor, 1979; Kluger & DeNisi, 1996; London, 1997; Pritchard, Jones, Roth, Stuebing, & Ekeberg, 1988). Similarly, the importance of feedback as a determinant of behavior receives much attention in the management literature (Balcazar, Hopkins, & Suarez, 1985; Locke & Latham, 1990). Feedback is a resource learned about directly on the job (Hackman, 1977) and through formal performance appraisals (Larson & Callahan, 1990; Pearce & Porter, 1986). Individuals deliberately react to feedback (Taylor, Fisher, & Ilgen, 1984) and purposely seek feedback (Ashford & Cummings, 1983). People have an intuitive interest in knowing "how they are doing," especially when their job depends on it. Thus, organizations continue to assess performance and implement feedback mechanisms.

Investigations of culture as a moderating factor in organizational theories are academic regularities as questions of generalizability have become an increasing point of discussion and concern (Bond & Smith, 1996; Boyacigiller, Kleinberg, Sackmann, & Phillips, 1996; Earley & Erez, 1997; Earley & Gibson, 1998). The current trend toward considering international management implications brings with it the proposition that

U.S. techniques for managing information for evaluations (by oneself and by others) of an individual's behavior might not be universally effective across different cultures (Earley, 1986, 1989).

Evaluation of an individual's behavior and performance is a complex, multifaceted process. On the one hand, organizations create appraisal and feedback processes to provide the individual evaluative information (Kluger & DeNisi, 1996). On the other hand, individuals engage in personally developed search strategies to acquire information for the purpose of self-evaluation (Sedikides, 1993). Feedback giving and feedback seeking are integral and reciprocal activities (London, 1997). Furthermore, feedback giving occurs across levels of analysis. For example, feedback can be provided at the individual level (e.g., supervisor, peers) or at the organizational level (e.g., unit reports, posted charts). Although a complete discussion would integrate all the levels of analysis and feedback-exchange activities, such an effort would be beyond the effective scope of a single paper. Recognizing this limitation, we do not attempt a comprehensive or exhaustive discussion here. Rather, we offer initial direction and propositions to spur research efforts. We focus our discussion primarily on how feedback-seeking behavior is influenced by the individual's cultural orientation. We also briefly examine how culture might affect organizational feedback giving, the recognized antecedent to an individual's feedback-seeking behavior (Ashford & Cummings, 1983: 375).

---

We thank Sue Ashford, Daniel Ilgen, Michael Morris, and Elizabeth Morrison for their constructive comments on earlier versions of this article. We also thank Chris Earley and two anonymous reviewers for their outstanding efforts during the review process.

Recent discussions indicate that individual behavior cannot be partitioned from the culture in which it occurs (Earley, 1997). We identify feedback giving and feedback seeking as such activities. Researchers have found that individuals in hierarchically structured cultures (those defined as more accepting of status differences) resist supervisor's influence attempts more and are less trusting of their supervisor's feedback (Earley & Stubblebine, 1989). Because feedback giving is affected by cultural characteristics (Earley, Gibson, & Chen, 1999), the solicitation of feedback might be impacted as well. However, in scant research have scholars investigated the challenges of cultural differences for feedback-seeking behavior. Gupta, Govindarajan, and Malhotra (1996) found different determinants of feedback-seeking behavior of subsidiary presidents in multinational corporations. Differences in information seeking across cultures have been implicitly demonstrated in research on social desirability (Markus & Kitayama, 1991).

Understanding the association and implications of culture and feedback-seeking behavior is important, yet research is only in nascent stages. What serves as a feedback-exchange request by an employee born or trained in one culture might not be correctly perceived and responded to by a manager born or trained in a different culture. It might be more inappropriate to ask direct questions in Taiwan in that it may create loss of face, yet this type of activity might be normal in Rome. Therefore, how feedback seeking is generated and responded to may need to be considered within a cultural context. In this article we theorize how feedback exchange can be assessed given various cultural orientations. We first examine the emerging concept of "cultural syndromes" (Triandis, 1996), increasingly used to organize multifaceted patterns of shared values, beliefs, and attitudes around a particular theme (e.g., Brett & Okumura, 1998; Chen, Chen, & Meindl, 1998). We then differentiate the processes of organizational feedback-giving behavior and individual feedback-seeking behavior. Finally, we propose the potential effects of these cultural syndromes on feedback-seeking behavior.

### CONCEPTUALIZATION OF CULTURE

Initial cross-cultural researchers used an inductive format to empirically identify, observe,

and measure differences. Through comprehensive research of one multinational organization, Hofstede (1980) developed four value dimensions along which culture may vary. Although he is the most widely cited, several scholars have noted the many value and relational dimensions that can be used to classify culture (Haire, Ghiselli, & Porter, 1966; Kluckhohn & Strodtbeck, 1961; Parsons & Shils, 1951; Ronen & Shenkar, 1985). Recently, researchers have appealed for studies stimulating a broader understanding of culture's complexity (Bond & Smith, 1996; Earley & Gibson, 1998; Osland & Bird, 2000). Meziar, Chen, and Murphy (1999) describe culture as beyond the programming of abstract values that people hold. They claim that "culture provides the categories by which we understand the world, and the scripts and schemes we use to guide behavior" (1999: 326; emphasis added). The concept of cultural syndromes recently has emerged as a method for researchers to examine culture as complex phenomena composed of interrelated cultural dimensions (Triandis, 1996). Syndromes can integrate and advance the field beyond lists of values presented as a simplistic and possibly misleading unidimensional continuum (Lytle, Brett, Barsness, Tinsley, & Janssens, 1995; Meziar et al., 1999; Osland & Bird, 2000).

The individualism-collectivism dimension illustrates this shift from cultural dimensions to cultural syndromes. How individuals view themselves in relationship to cultural peers is extensively researched and considered a core cultural dimension (Earley, 1997; Schwartz, 1992; Triandis, 1989; Trompenaars, 1993). Although a diversity of operationalizations exists, the broad range of findings shows some conceptual and empirical convergence. Briefly, there is a tendency to find more individualistic themes in Western and more collectivist themes in traditional Eastern cultures (Triandis, 1989, 1995). Recent research, however, has shown this dimension to be more multifaceted in structure and more complex in application (Triandis & Geland, 1998).

Scholars have recommended not only expanding the population but also the construct of research interest (Bond & Smith, 1996; Earley & Gibson, 1998; Lytle et al., 1995). Following this advice, we identify four cultural syndromes that we propose will influence feedback-seeking behavior. Triandis (personal communication)

states that a syndrome can be constructed when (1) one observes a set of cultural attributes (e.g., dimensions) that describe values, norms, attitudes, and self-construals that vary less within than across cultures, and (2) these attributes (dimensions) can be shown to conceptually and empirically share an underlying theme. Earley (1997) used this approach to consolidate existing dimensions in three syndromes (relation of the person to [1] social structure, [2] the environment, and [3] self). In doing so, he could develop a parsimonious examination of culture's effect on "face"-related issues. Using this same approach, we surfaced the following four syndromes from a comprehensive review of the literature across several disciplines: (1) specific-holistic orientation, (2) tolerance for ambiguity, (3) individualism-collectivism, and (4) status identity.

For example, we propose a syndrome called "specific-holistic." We found several existing constructs that speak to the "richness" of an individual's relationship with others. In Hall's construct he describes a high-context culture as one in which information exchange takes place through many "channels" beyond simple words (1976: 98). Hall describes the variety of cues that should inform a recipient of the sender's concerns without having to directly verbalize the issue. Hall's work is commonly interpreted to describe communication interactions. His language bears similarity to Parsons and Shils' (1951) concept of specific-diffuse cultures that differ in their expectation of the number of connections people possess within a relationship. Common examples include the extent to which Japanese and Russians expect to know the person holistically before doing business, whereas U.S. individuals significantly compartmentalize personal and professional interaction. Historically, in the social networks literature and, recently, in the trust literature (e.g., Lewicki, McAllister, & Bies, 1998) scholars use the term *multiplexity* to describe the "bandwidth" of relationship links. Our intent is to use this syndrome to signal this common theme showing the existence of and need to understand the multitude of interpersonal connections.

Table 1 provides an extended listing of the scholars and the focus of their research that we used as the foundation for our syndromes. We do not mean our efforts be taken as an exhaustive and/or replacement model of existing research.

Rather, we seek to use emerging theory to create a consolidated yet comprehensive lens to examine the culture/feedback-seeking behavior interaction. The table presents each syndrome created for our current discussion. Underneath each syndrome, on the left, are the past works we see as sharing the underlying theme we identify. To the right we list some of the more commonly recognized cultural dimensions resulting from the listed works.

Like previous researchers (Chen, Brockner, & Katz, 1997; Earley, 1997; Peterson & Smith, 1997; Schwartz, 1992), we restrict our discussion to individual-level behavior. Naturally, this raises levels-of-analysis issues (Klein, Dansereau, & Hall, 1994)—a problem widely discussed in the cross-culture literature (Bond & Smith, 1996). For example, Hofstede focuses on the societal level of analysis, whereas Schwartz examines the individual level. In the growing "meso" approach, ways to reduce concerns in the organizational behavior field in general (e.g., Chen et al., 1998) and cross-culturally in particular (Brett & Okumura, 1998; House et al., 1995) have been discussed. Yet, although scholars recommend more meso efforts (Earley, 1997: 11), they also tend to stay within their disciplinary "comfort zone" (Earley, 1997: 21). Even so, current research supports assessing culture-level concepts vis-à-vis the individual level (Brett & Okumura, 1998; Earley et al., 1999; Lytle et al., 1995), as well as convincingly aggregated to the group level (Gibson, 1999). Given the development of and the desire for clarity of presentation, we believe this boundary is warranted.

## FEEDBACK AND FEEDBACK-SEEKING BEHAVIOR

Feedback is a multifaceted term in psychology, organizational behavior, and other social science literature. Early empirical research in psychology indicated that motivation and performance are significantly influenced by feedback (Ammons, 1956). Closer analysis reveals two primary research camps that examine feedback. One looks at feedback as an organizational resource (Ilgen et al., 1979; Prue & Fairbank, 1981), addressing such issues as interventions (Kluger & DeNisi, 1996) and incentives (Ganzach, 1994). The other camp views feedback from the perspective of the individuals engaged in the behavior being evaluated (Ashford & Cum-

**TABLE 1**  
**Feedback-Exchange-Related Cultural Syndrome Characteristics**

Syndrome	Characteristics
<b>Specific-holistic orientation</b>	
Hall (1976)	• High context/low context
Gruenfeld & MacEachron (1975); Witkin, Goodenough, & Oltman (1979)	• Field dependent/independent
Parsons & Shils (1951); Trompenaars (1993)	• Specific-diffuse
Adler, Doktor, & Redding (1986); Bloom (1981); Bond (1986); Redding (1980)	• Holistic-linear
<b>Tolerance for ambiguity</b>	
Chan, Gelfand, Triandis, & Tzeng (1996); Pelto (1968); Triandis (1989); Witkin & Berry (1975)	• Tight/loose
Hofstede (1980)	• Uncertainty avoidance
Chinese Culture Connection (1987)	• Confusion dynamism
Dawson, Law, Leung, & Whitney (1971)	• Traditional/modernity
Kedia & Bhagat (1988)	• Absorptive capacity
Berger (1979); Gudykunst (1983)	• Uncertainty reduction
<b>Individualism-collectivism</b>	
Hofstede (1980); Triandis (1989, 1995)	• Individualism/collectivism
Earley (1993); Hui (1988)	• Ingroup/outgroup
Kluckhohn & Strodtbeck (1961)	• Individualism/collaterality
Parsons & Shils (1951)	• Self-orientation/collectivity orientation
Schwartz (1992)	• Self-enhancement/self-transcendence
Banfield (1958)	• Familism
Morris (1956)	• Social restraint/self-control
Schwartz (1992)	• Autonomy/embeddedness
<b>Status identity</b>	
Leung (1997); Schwartz (1994); Triandis (1982)	• Hierarchy/egalitarian
Hofstede (1980)	• Power distance
DeVos & Suarez-Orozco (1990)	• Status equality
Parsons & Shils (1951)	• Achievement/ascription
Barrett & Bass (1967); Whyte (1963)	• White-collar/Pan-worker orientation
Sarnoff (1966)	• Prestige/humility
Schwartz (1992)	• Egalitarian/hierarchy

mings, 1983) and identifies them as proactive in obtaining information useful for self-assessment (Sedikides, 1993).

Feedback, as an organizational resource, is traditionally considered a stimulus manipulated to influence behavior (Stajkovic & Luthans, 1997). It is largely regarded as something transmitted to the individual to produce a desired behavior (Herold & Geller, 1977; Ilgen et al., 1979; Locke, 1980), and individuals are assumed to perceive and respond to the feedback message (Bandura, 1991; Locke & Latham, 1990; Podsakoff & Farh, 1989). Those in the field of organizational behavior continue to promote feedback as a cue for motivation, performance, and learning (Castellan & Swaine, 1977; Earley, 1988; Koestner, Zuckerman, & Koestner, 1987; Lee & Yates, 1992; Vroom, 1964). Much of this literature is concerned with showing the effectiveness of feedback on influencing future individual behavior and performance (Cusella, 1987; Guzzo, Jette, &

Katzell, 1985; Ilgen et al., 1979). Others (Balcazar et al., 1985; Goltz, Citera, Jensen, Favero, & Komaki, 1989; Kluger & DeNisi, 1996; Waldersee & Luthans, 1994), however, have found that not all feedback interventions result in improved performance and, in fact, may often create inconsistent results (Salmoni, Schmidt, & Walter, 1984). The combination of mixed findings relating to the effectiveness of performance feedback indicates the complexity of this issue.

The effectiveness of any single type of feedback is influenced by individual differences in performance level, ability, and emotion (Arvey & Ivancevich, 1980). Feedback, it is suggested, should be prudently modified to fit the receiver to whom it is addressed in order to maintain appropriate levels of effort and performance (Ackerman, 1987). We suggest culture also deserves attention as a criterion for modifying the nature of feedback given to individuals for evaluation purposes. Although in few studies (e.g.,

Earley & Stubblebine, 1989; Markus & Kitayama, 1991) have researchers explored the relationship between culture and the nature of feedback given, there are a few items that hold the most promise for initiating this investigation. For example, quality and quantity feedback have shown great efficacy for the evaluation and improvement of behavior and performance (Locke & Latham, 1990; Stajkovic & Luthans, 1997). We know the United States, where these findings are based, is a low-context culture (Hall, 1976) that focuses on specific criteria-relevant (task, social fit) information to the exclusion of feedback context and other implied information. High-context cultures perceive additional feedback cues from nonverbal behaviors, feedback setting, and actor status. Thus, culture might affect the way feedback is given, and such differences might influence if and how potential feedback-seeking behavior occurs. However, our objective in this article is to first understand how people seek feedback before we begin to understand what kind of feedback they seek.

Ashford and Cummings (1983) pioneered the concept of feedback-seeking behavior as the interest an individual has in obtaining information key in developing his or her self-concept (Ashford & Northcraft, 1992; Morrison & Bies, 1991; Sedikides, 1993; Swann, Pelham, & Krull, 1989; Swann, Stein-Seroussi, & Giesler, 1992) and performance (Morrison & Cummings, 1992; Northcraft & Ashford, 1990; Trope, 1975; Trope & Neter, 1994; Wayne & Liden, 1995). This seminal work on feedback-seeking behavior (Ashford & Cummings, 1983) was formulated, in part, by the authors' recognition of the need to customize feedback quantity and quality to the individual—a need often not met by the organization. Theoretically important, feedback was said to be not only an organizational resource but also an individual resource.

Feedback-seeking decisions involve evaluating three types of cost: (1) *effort costs*: the effort necessary for the feedback search; (2) *face costs*: the evaluative effects of others on the individual for seeking; and (3) *inference costs*: the implications of inferential errors resulting from inaccurately interpreting feedback (Ashford & Cummings, 1983). Coupled with the cost of the feedback-seeking decision is the concept of uncertainty reduction. It is the existence of evaluative uncertainty that makes feedback valuable (Festinger, 1957; Trope, 1975, 1980). When indi-

viduals experience information uncertainties (Ashford & Cummings, 1983; Kramer, 1994; Miller & Jablin, 1991), they will be motivated to seek feedback (Ashford, 1986; Brett, Feldman, & Weingart, 1990; Callister, Kramer, & Turban, 1999; Feldman & Brett, 1983). There is ample evidence to show that people not only have different tolerance levels at the individual level (Budner, 1962; Festinger, 1957; Norton, 1975) but also as a result of their cultural background.

Several distinct strategies exist for seeking feedback (Ashford, 1986; Ashford & Cummings, 1983; Fedor, Rensvold, & Adams, 1992; Feldman & Brett, 1983; Larson, 1989; Miller & Jablin, 1991; Tsui, Ashford, St. Clair, & Xin, 1995). Through inquiry, individuals directly solicit others' perceptions and evaluations (Morrison & Bies, 1991; Northcraft & Ashford, 1990; Vancouver & Morrison, 1995). Through monitoring, individuals interpret any action or lack of action by others as a form of feedback (Feldman & Brett, 1983), vicariously observing how selves and others are responded to and reinforced (Ashford, 1986; Bandura, 1977). In research on organizational newcomers, Miller and Jablin (1991) introduce an additional strategy of indirect inquiry (comprising indirect questions, third parties, testing limits, and disguising conversation tactics). The intent of indirect strategies is to maximize the feedback function while minimizing the costs. To illustrate, in a culture in which asking questions of superiors is not common practice, individuals might feel hindered from using direct inquiry because the evaluative costs might be too high. Such generic discussions of expectations and historical examples may provide the desired information without either side needing to admit implications for the specific individual.

Individuals also engage in feedback-seeking source choices (Ashford & Tsui, 1991; Callister et al., 1999; Levy, Albright, Cawley, & Williams, 1995). Based on the premise that they are motivated by the drive to know, individuals are compelled to seek comparison information from referent others (Festinger, 1954; Suls & Wills, 1991). This facilitates an understanding of how they rank in relation to others (Wheeler, 1966), especially those who are perceived to rank higher (Gruder, 1977). Sources from whom individuals can obtain this information include their superiors, their peers, and/or their subordinates. Accessibility of the source, its credibility, and the possible affective sign of the information may

influence source selection (Ashford & Tsui, 1991; Morrison & Bies, 1991; O'Reilly, 1983; Vancouver & Morrison, 1995). In organizations individuals frequently look for information to formulate attitudes for behavioral actions (Salancik & Pfeffer, 1978), and they may obtain performance-enhancing feedback through sources apart from their supervisor (Morrison, 1993; Ostroff & Kozlowski, 1992).

Coupled with the cost of seeking feedback is the notion of individual motives in the feedback process. Evaluative costs may lend themselves to a self-focus in an individualist culture but a group focus in a collectivist culture. Indeed, research has shown self-enhancement, ego defense, and impression management to be affective concepts in feedback seeking (Ashford & Northcraft, 1992; Brown & Dutton, 1995; Edwards, 1995; Vancouver & Morrison, 1995; Wood, 1989). Additionally, the feedback context is an important determinate of feedback-seeking behavior (Levy et al., 1995; Northcraft & Ashford, 1990). Feedback context determines the nature and boundaries of the environment in which feedback is sought and received. For example, in a low tolerance for ambiguity culture, there might be organizational structures implemented to help define the context of the organization. In a holistic culture much of the message meaning is in the environment. Therefore, a less threatening context may reduce feedback-seeking costs.

### TOWARD A CULTURAL TAXONOMY OF FEEDBACK-SEEKING BEHAVIOR

We adopt a contingency perspective (e.g., Chen et al., 1998; Gibson, 1999) that feedback-exchange foci, strategies, sources, structure, and provider will differ across cultures. It is not our intention to delineate every feedback-seeking interaction across each cultural dimension. Rather, our purpose is to begin research efforts by showing the topic's rich potential. Here we discuss and propose those culture/feedback-seeking behavior interactions that are demonstrated by or can be derived from existing literature. We present these propositions in Table 2. The empty cells represent propositions that could not be resolved by (e.g., competing evidence) or grounded in existing literature. That said, in the rest of our discussion, we examine how the identified syndromes might affect the feedback-seeking process. We consider

if and to what degree contextual considerations (situational and cultural) affect an individual's feedback seeking. We then consider culture's impact on perceptions of feedback-seeking behavior costs and how one chooses to seek feedback (e.g., direct inquiry, indirect inquiry, or monitoring strategies). Finally, we analyze who it is that individuals determine is the best source of information (subordinates, peers, or supervisors).

### The Impact of Specific-Holistic Orientation on Feedback-Seeking Behavior

The focus of the specific-holistic syndrome involves the manner in which a culture "understands" the richness of relationships. This syndrome also addresses how one cognitively and contextually processes information. Mezas et al. (1999) allude to this when they suggest that a larger network of actors and their complexity of relations must be considered in the multinational, multicultural workplace.

The specific-holistic theme surfaces across cultural models (Adler et al., 1986; Bloom, 1981; Bond, 1986; Gruenfeld & MacEachron, 1975; Redding, 1980) and is closely associated with the idea of field independence (Gibson, 1999; Witkin et al., 1979). Some cultures, such as that of the United States, tend to conceptualize life quite specifically, viewing interactions through an effect/outcome-oriented focus. Specific-oriented cultures compartmentalize areas of life experiences (job, family, and education), commonly avoiding overlap between areas. Conversely, the Chinese understanding of and reliance on *yuan* implies that the Chinese read the meanings and signs in their environment. Holistic-oriented cultures blend areas of life, seeing them as interdependent, rather than separate. They rely less on taking control of the environment (Yang & Ho, 1988; Yang & Tsai, 1996), especially in organizations.

This syndrome includes contrasting interactions that occur in communication. Hall (1976) describes variation of focus on "code and context" as a difference between high-context and low-context culture. Low-context cultures use explicit and direct messages in which meanings are contained primarily in transmitted communication (Singelis & Brown, 1995). In contrast, high-context cultures use indirect and implicit messages in which meanings are embedded in

the person and the sociocultural context (Gudykunst, Matsumoto, Ting-Toomey, Nishida, Kim, & Heyman, 1996). Although people in any culture use both high- and low-context communication, one form is favored over the other in most cultures (Hall, 1976). Communication interactions transpiring in a holistic culture commonly involve nonlinear message transaction. Interactions in a specific-oriented culture are more linear and involve instrumental transfer of information.

Specific-holistic is also directly related to the cultural relational construct of specific-diffuse (Parsons & Shils, 1951; Trompenaars, 1993). People from diffuse cultures view the business-personal interrelatedness as important in revealing character and in developing trust. Investing time in establishing relationships and revealing personality is fundamental and at times might supersede the actual business deal. The belief that one's public and business behavior should be separate or different from private behavior would be inconceivable in a culture that adheres to *guan xi* (Schermerhorn & Bond, 1991). Specific-oriented cultures tend to isolate their relationship perspective to those elements directly involved in the exchange.

Organizations provide feedback to their members (Funderburg & Levy, 1997; Ilgen et al., 1979; London, 1997) and across societies (Earley, 1997; Earley & Stubblebine, 1989). Societal norms shape the feedback process and impact the exchange of information. Contextual issues also become salient features of providing feedback in both holistic and specific cultures. In a highly holistic culture, however, where a high degree of message meaning exists in the organizational context, feedback also might be derived by the physical context and nonverbal cues. In some cases the setting itself may be a message, without a need for verbal interaction. Thus, we offer the following propositions.

*Proposition 1a: Organizations operating in a holistic-oriented culture will convey feedback more through context, using indirect and implicit messages.*

*Proposition 1b: Organizations operating in a specific-oriented culture will convey feedback more through information exchanged by direct messages.*

When organizational feedback is inadequate for self-assessment, individual feedback seeking occurs. The cost of such activity, however, influences whether this intent becomes action. Researchers have found that over time, individuals seek less feedback in public contexts (Ashford & Northcraft, 1992) and that seeking in private and semi-private contexts slightly increases (Levy et al., 1995). Scholars have used these results to advance the notion that feedback-seeking costs diminish feedback-seeking behavior. However, these studies were conducted in the United States—a highly specific culture (Trompenaars & Hampden-Turner, 1998).

In holistic cultures much time is taken establishing relationships and behaving in ways to avoid losing face (Earley, 1997). In recent discussions researchers detail the notion of multiplex and deep trust relations (Lewicki et al., 1998). In a holistic-oriented relationship it is also extremely difficult to not take things personally. Thus, given the importance of developing an exchange relationship and remaining nonconfrontational (Trompenaars & Hampden-Turner, 1998), individuals will go to great extremes to save face. They do not want to disrupt the harmony of the relationship. Face costs, therefore, would be a significant consideration in determining if one should seek information. Indeed, the feedback may be used to evaluate the relationship.

People from a specific-oriented culture may view transactions with others from diffuse-oriented cultures as time consuming and unfocused (Trompenaars, 1993). Given "business is business," they would not expect feedback, or the seeking of it, to have personal consequences for the parties beyond its job-relevant evaluative potential. Put differently, social courtesies would not be required before "getting to the point." In a specific cultural context, decisions to seek feedback most likely would be based on inference and effort costs. That is, the resources necessary versus the potential for interpretation error (Ashford & Cummings, 1983) would be the dominant considerations. Given this, we advance the following propositions.

*Proposition 2a: Feedback-seeking behavior by individuals shaped by a holistic-oriented culture is more likely to be influenced by face costs.*



**TABLE 2**  
**Summary Chart of Propositions**

**Cultural Syndrome**

<b>Feedback Activity</b>	<b>Specific-Holistic Orientation</b>	<b>Tolerance for Ambiguity</b>	<b>Individualism-Collectivism</b>	<b>Status Identity</b>
Feedback providing	<p>Proposition 1a: Organizations operating in a holistic-oriented culture will convey feedback more through context, using indirect and implicit messages.</p> <p>Proposition 1b: Organizations operating in a specific-oriented culture will convey feedback more through information exchanged by direct messages.</p>	<p>Proposition 4: Organizations operating in a low tolerance for ambiguity culture will use more formal rules, procedures, and structure for providing feedback than cultures depicted by a high tolerance for ambiguity.</p>	<p>Proposition 7a: Organizations operating in an individualistic culture will provide more individual-focused feedback.</p> <p>Proposition 7b: Organizations operating in a collectivist culture will provide more group-focused feedback.</p>	<p>Proposition 9a: Organizations operating in a higher status identity culture will convey feedback more frequently through a top-down feedback process.</p> <p>Proposition 9b: Organizations operating in a lower status identity culture will convey feedback more frequently through an interactive feedback process (i.e., 360 degrees).</p>
Feedback-seeking behavior		<p>Proposition 5: In high-uncertainty contexts, individuals shaped by low tolerance for ambiguity cultures will engage in greater feedback seeking.</p>		
Cost of seeking feedback	<p>Proposition 2a: Feedback-seeking behavior by individuals shaped by a holistic-oriented culture is more likely to be influenced by face costs.</p> <p>Proposition 2b: Feedback-seeking behavior by individuals shaped by a specific-oriented culture is more likely to be influenced by effort and inference costs.</p>	<p>Proposition 6: In high-uncertainty contexts, individuals shaped by low tolerance for ambiguity cultures will be less influenced by feedback-seeking costs.</p>		<p>Proposition 10: Individuals shaped by a higher status identity culture will see feedback-seeking costs as greater than individuals from a lower status identity culture.</p>

Strategy for seeking feedback

Proposition 3a: Individuals shaped by a specific-oriented culture will more frequently use direct-inquiry feedback-seeking strategies.  
 Proposition 3b: Individuals shaped by a holistic-oriented culture will more frequently use monitoring and indirect-inquiry feedback-seeking strategies.

Proposition 8a: Individuals shaped by an individualistic culture will more frequently use direct-inquiry feedback-seeking strategies.  
 Proposition 8b: Individuals shaped by a collectivist culture will more frequently use monitoring and indirect-inquiry feedback-seeking strategies.

Proposition 11a: Individuals shaped by a lower status identity culture will use more direct-inquiry feedback-seeking strategies.  
 Proposition 11b: Individuals shaped by a higher status identity culture will use more monitoring and indirect-inquiry feedback-seeking strategies.

Source for seeking feedback

Proposition 12a: Individuals shaped by a higher status identity culture will seek feedback from peers more than from superiors and subordinates.  
 Proposition 12b: Individuals shaped by a lower status identity culture will seek feedback from superiors and subordinates more than from peers.

*Proposition 2b: Feedback-seeking behavior by individuals shaped by a specific-oriented culture is more likely to be influenced by effort and inference costs.*

Once the decision to seek feedback is made, culture will influence the method by which it is sought. Specific-oriented individuals prefer to "get to the point" and to "ask a question up front." In the United States (a specific-oriented culture) individuals will immediately ask questions in business transactions to clarify particular points (Johnson, 1996). Information seeking is salient in both cultures, but specific-oriented individuals will favor a more intensive direct-inquiry approach. The holistic-oriented individual, interested in the feedback interaction as much as the feedback itself, will prefer more indirect inquiry and intensive monitoring strategies.

Implications of this syndrome can be found in recent research on newcomers in U.S. organizations. In this work researchers note that information acquired must be assimilated quickly because, typically, especially in American companies, impressions are formed very rapidly about an organization member's capabilities (Callister et al., 1999; Johnson, 1996). The implication is that the only interaction that matters is the professional relationship. Thus, one will likely be motivated to obtain job-related information quickly and unambiguously. The information exchange is specific to the business at hand and, as such, direct questions are appropriate to glean information. In holistic-oriented cultures, evaluations involve more than just the specific task behaviors. Instead, the evaluation also involves long-term implications, including one's ability to "fit in." Judgments are less obvious (again, the context is as important as the content) and slower to materialize. Given this, we propose the following.

*Proposition 3a: Individuals shaped by a specific-oriented culture will more frequently use direct-inquiry feedback-seeking strategies.*

*Proposition 3b: Individuals shaped by a holistic-oriented culture will more frequently use monitoring and indirect-inquiry feedback-seeking strategies.*

### **The Impact of Tolerance for Ambiguity on Feedback-Seeking Behavior**

The cultural syndrome tolerance for ambiguity refers to the extent to which ambiguous situations are seen as threatening. The need to reduce uncertainty is a relevant consideration across several levels of analysis, from the individual to the cultural level (Dawson et al., 1971), and encompasses the notion of an uncertainty comfort level. Festinger (1957) refers to this concept in his work on individual cognitive dissonance. Tolerance for ambiguity also includes the degree to which society members are open to change and innovation (Kedia & Bhagat, 1988). This syndrome includes the uncertainty avoidance cultural dimension of the Hofstede model (1980) and is highly associated with formalization (Shackleton & Ali, 1990) and uncertainty reduction (Berger, 1979). In low tolerance for ambiguity cultures, managers take fewer decision-making risks, and there is extensive reliance on rules and procedures. High tolerance for ambiguity cultures are more accepting of uncertainty (Earley & Stubblebine, 1989), and individuals are not threatened by opinions and behaviors different from their own (Berger, 1979).

A related dimension of culture is "tight versus loose" (Chan et al., 1996; Earley, 1997; Pelto, 1968; Triandis, 1996), which delineates how rules and norms exist in and are enforced by a society (Pelto, 1968; Witkin & Berry, 1975). Low tolerance for ambiguity (tight) cultures are characterized by many rules. Individuals are expected to conform to standard practices (Triandis, 1989), and deviations are discouraged. In such cultures significant formal information systems are incorporated into organizational structures (Earley, 1997). These systems are designed to reduce ambiguity, deviant behavior, and possibly the need for seeking feedback. In high tolerance for ambiguity (loose) societies, a wide range of alternative channels exist through which norms are relayed, and the culture is more flexible in imposing norms (Triandis, 1989). Adherence to formal organizational procedures is less enforced, and values such as stability, solidarity, and duration are not accentuated. In addition, managers have a stronger interpersonal style in their interaction with subordinates, employees tend to be more ambitious, and work tends to be less structured (Earley, 1997).

Based on this syndrome, we advocate a cultural contingency model (Chen et al., 1998) for understanding the feedback process. This argument is consistent with the perspective that cultural variables might moderate macrolevel factors, such as organizational structure (Child, 1981; House, Rousseau, & Thomas-Hunt, 1995). Other research shows that organizational structure and technology might affect the feedback process by creating settings in which feedback is differentially provided to individuals (Ashford, 1986). In the United States, a high tolerance for ambiguity culture, the feedback process is less focused on formal structure (Shackleton & Ali, 1990). In low tolerance for ambiguity cultures, the feedback process is focused on the formal structure to create a method of ego defense (Shackleton & Ali, 1990). In practice, low tolerance for ambiguity cultures have successfully employed the use of quality-control circles to stabilize environmental uncertainty (Hofstede, 1980). On the basis of these considerations, we propose the following.

*Proposition 4: Organizations operating in a low tolerance for ambiguity culture will use more formal rules, procedures, and structure for providing feedback than cultures depicted by a high tolerance for ambiguity.*

However, these embedded systems might not be adequate to satisfy people's need for self-evaluation; thus, some uncertainty will remain. The underlying premise of research on feedback seeking is the important informational role feedback plays in reducing uncertainty and achieving goals (Morrison, 1995). One's capacity to cope with ambiguity will influence motivation to perform an information search (Ashford & Cummings, 1985), and culture is a determinant of this capacity (Trompenaars, 1993). The propensity for low tolerance for ambiguity cultures is to avert risk and uncertainty, and feedback-seeking behavior is one such activity for this. High tolerance for ambiguity cultures are more accepting of and less threatened by risk and uncertainty. Support for this premise is found in research at the individual (Ashford & Cummings, 1985; Fedor et al., 1992) and cultural level (Earley, 1997, or Erez & Earley, 1993), showing that individuals who are intolerant of ambiguity seek more information relative to individuals who are tolerant of ambiguity. Although we pro-

pose an apparent parallel, Bond and Smith (1996) caution against operationalizing or generalizing across levels of analysis. Our intent here is to point out the observation of similar effects at different levels and the need for research to bridge the gap. Given this, we propose the following.

*Proposition 5: In high-uncertainty contexts, individuals shaped by low tolerance for ambiguity cultures will engage in greater feedback seeking.*

Ashford (1986) argues that uncertainty should be positively correlated with how much an individual values feedback and how much culture influences perceptions of value (Dawson et al., 1971). Value is one's expected degree of return, compared to the cost of action. Given that feedback-seeking behavior is affected by costs (Ashford & Cummings, 1983) and value is affected by culture, we infer that culture—in particular, tolerance for ambiguity—will affect feedback seeking through the differing perceptions of cost. The more one is threatened by ambiguity, the greater one will feel the drive to reduce uncertainty and inference costs (greater return). Thus, an individual with lower tolerance for ambiguity will perceive effort (and face) as less costly, given the benefit (Berger, 1979). Based on these considerations, we offer the following proposition.

*Proposition 6: In high-uncertainty contexts, individuals shaped by low tolerance for ambiguity cultures will be less influenced by feedback-seeking costs.*

### **The Impact of Individualism-Collectivism on Feedback-Seeking Behavior**

All cultures have characteristics broadly defining their social identity. Social identity is defined as the relation of the person to the whole (Tajfel & Turner, 1986) and is a universal principle. Although the effect is universal, the meaning is specific to culture (Pepitone & Triandis, 1988). Social identity comprises such concepts as face saving (Earley, 1997; Goffman, 1959; Triandis, 1990; Yang & Tsai, 1996) and achievement purposes (Katakis, 1976). Cross-cultural researchers have tended to focus on the issue of cultural social identity through a construct

scholars have labeled "individualism-collectivism" (Erez & Earley, 1993; Hofstede, 1980; Triandis, 1995; Triandis & Gelfand, 1998). Cited as the most widely studied cultural dimension, the recent conceptualization of individualism-collectivism as a syndrome has led to greater sophistication in its investigation and implications (Chen et al., 1998; Triandis, 1996). Often presented as opposing points on a continuum (Earley, 1989; Hofstede, 1980), individualism-collectivism recently has been shown as two independent factors (Triandis, 1995) and has been conceptualized as a multidimensional and multilevel construct (Earley & Gibson, 1998; Earley et al., 1999; Schwartz, 1990; Triandis, 1995).

In an individualistic culture there is an intrinsic belief in individual decisions (Kluckhohn & Strodtbeck, 1961), and, thus, individual goals become the primary focus of behavior (Triandis, 1990). Individualism corresponds to the primacy people place on themselves over their aggregate social group. In studies conducted predominantly in the United States, considered a highly individualistic culture, researchers found individuals to be concerned with self-accuracy (Fedor et al., 1992; Swann et al., 1989), self-assessment (Vancouver & Morrison, 1995), and self-regulation (Ashford & Tsui, 1991).

Collectivism exemplifies a societal situation in which people belong to groups or collectivities that share a reciprocal concern for each other (Triandis, 1995). Such cultures emphasize the priority of the group over an individual, including how a person's behavior impacts the group (Brockner & Chen, 1996; Earley, 1993; Hui, 1988). For the collectivist there exists an intrinsic belief in group decisions, and, thus, the focus becomes that which benefits the goals of the group.

In collectivist cultures information pertaining to the group should be more valued than knowledge pertaining to the individual. Individualist cultures should value feedback directed to each person (Greenwald & Pratkanis, 1984; Triandis, 1989). The scant empirical research shows mixed results. Although some studies show a clear distinction between individualism-collectivism and focus of information (Markus & Kitayama, 1991; Triandis, 1989), others show less distinctive results. For example, Earley et al. (1999) found collectivist societies value both types of feedback, although these scholars urge caution

given the limited sample and potential lack of psychological realism. We propose the following.

*Proposition 7a: Organizations operating in a individualistic culture will provide more individual-focused feedback.*

*Proposition 7b: Organizations operating in a collectivist culture will provide more group-focused feedback.*

We postulate that individuals shaped by both cultures engage in feedback-seeking behavior. The difference is whether the benefit is provided to the group or the individual. In an individualistic environment individuals will be more interested in feedback due to effects on self-concept (Swann & Read, 1981). They will likely seek feedback as a means of personal impression management (Morrison & Bies, 1991; Wayne & Liden, 1995) or ego protection (Larson, 1989), since looking after one's self is paramount. Such impression management concerns also exist at the group level, in the form of social identity (Tajfel & Turner, 1986). Thus feedback-seeking behavior will still be observed in collectivist cultures, yet the emphasis will be on the betterment of the group through improving accuracy and understanding the task (Trope, 1975, 1982). We do not expect differences in inclination to seek feedback, but we do expect there to be a cultural influence on how it is sought.

A culture with a high collectivist orientation will not encourage direct-inquiry behavior since it might bring too much individual attention to a person or the group. In such environments indirect inquiry and monitoring may be a preferred mode of seeking feedback. Cultures with more of a collective identity favor behavior in harmony with the group (Earley, 1993; Hui, 1988; Triandis, 1990). Members would be more likely to ask, "How are we doing?" Further, this behavior reflects honor to the group and sacrifice of self. Individual notoriety is less important than in cultures with more of an individual identity; in fact, individual notoriety might be disruptive to the collective (Parsons & Shils, 1951; Schwartz, 1992). Given this, the following propositions are advanced.

*Proposition 8a: Individuals shaped by an individualistic culture will more frequently use direct-inquiry feedback-seeking strategies.*

*Proposition 8b: Individuals shaped by a collectivist culture will more frequently use monitoring and indirect-inquiry feedback-seeking strategies.*

### **The Impact of Status Identity on Feedback-Seeking Behavior**

The cultural syndrome of status identity embodies the notion that cultural members are stratified into categories or a hierarchy based on culturally salient criteria. This syndrome is composed of myriad cultural values, beliefs, and behaviors (DeVos & Suarez-Orozco, 1990). DeVos emically describes status inequality, a component of status identity, best "as modalities of expected behavior reinforced externally by formal or informal sanctions and expectations, and internally by the predisposing personality propensities set up by prior socialization" (1990: 28). Identity begins early in cultural development, involves a "selective permeability" to social experience, and relies on structural mechanisms of internalization that differentiate individuals within a society (Barrett & Bass, 1967). Status encompasses concepts of age, gender, class, caste, and ethnic behavior. It involves the experience of intentionality, power, and causality occurring within as well as external to the individual (DeVos, 1990).

This syndrome also encompasses many aspects of achievement-ascription relational cultural orientation (Parsons & Shils, 1951; Trompenaars, 1993). Some societies accord status to people on the basis of achievements, whereas other cultures determine status partially through the respect and loyalty given a person because of such factors as birthright, gender, and so forth. Status differentials are assigned. Societies characterized by achievement are labeled "lower status identity cultures"; societies characterized by ascription are labeled "higher status identity cultures."

Also included in this syndrome is how the value of hierarchy versus egalitarianism creates assumptions about how power and status are perceived in a culture (Brett & Okumura, 1998; Leung, 1997; Triandis, 1982). Hierarchical cultures favor differential social status, implying distribution of social power. Higher-status members have a degree of social responsibility to lower-status members of the society. Lower-status members concede respect to higher-

status members (Brett & Okumura, 1998). In egalitarian cultures social status differences exist, but individuals are less receptive to power differentials (Leung, 1997). Egalitarian cultures prefer equal power and engagement in social interaction; hierarchical cultures, however, expect unidirectional interactions (Triandis, 1982).

The notion of status identity is also seen in research on power distance (Earley, 1997; Hofstede, 1980): the extent to which power is distributed across members of a culture. A low power distance culture is characterized by a society of people having equal rights, exemplified by cooperation across the powerful and powerless. Notably, a lower status identity culture environment presents a more equal sharing of power and, thus, information between organizational members. A higher status identity culture distributes power unequally, with those individuals in higher-power positions allowed special privileges not afforded the less powerful (DeVos & Suarez-Orozco, 1990; Triandis, 1990). In a study on influence tactics, Hong Kong respondents (high power distance) were less likely to use ingratiation with their superiors than were their U.S. counterparts (low power distance) but were more likely to use assertiveness, especially with subordinates (Schermerhorn & Bond, 1991). Ingratiation is less frequent, some suggest, because the Chinese strongly foresee reprisals for infringing on the implied high-status culture environment. U.S. respondents used assertiveness tactics more often because they expect greater resistance in their egalitarian culture. Based on these arguments, we advance the following propositions.

*Proposition 9a: Organizations operating in a higher status identity culture will convey feedback more frequently through a top-down feedback process.*

*Proposition 9b: Organizations operating in a lower status identity culture will convey feedback more frequently through an interactive feedback process (i.e., 360 degrees).*

This has several implications for feedback-seeking behavior. First, single-source feedback systems are not as information rich as multiple-source systems (London, 1997). As such, feedback given in higher status identity cultures is likely to be less adequate than feedback given

in lower status identity cultures, thus contributing to inference costs. Second, the act of soliciting feedback, especially vertically, is likely to be interpreted differently based on status identity. In a higher status identity culture, interaction can bring great gain or great loss. For example, seeking information might be seen as an insult in higher status identity cultures—an indirect criticism of the superior's or the organization's effectiveness. Thus, face costs may be more severe. Finally, the social distance that exists is likely to create differences in the effort required to obtain sufficient feedback for self-evaluation. In the United States (proposed to be a lower status identity culture) managers were found to more actively seek feedback from superiors (Ashford & Tsui, 1991). The equal power distribution in lower status identity cultures might allow workers to move more easily up the organization pyramid, or throughout the organization network, when engaging in feedback-seeking strategies. We propose perceived status identity differences will result in different calculations of feedback-seeking costs. Given this, we suggest the following.

*Proposition 10: Individuals shaped by a higher status identity culture will see feedback-seeking costs as greater than individuals from a lower status identity culture.*

By extension, status identity differences also will affect the strategies employed to obtain feedback. In their research on power distance, Earley and Stubblebine (1989) found that cultures such as that of the United States evoke cooperation and an openness to discourse across organizational levels. Direct-inquiry feedback-seeking strategies might be encouraged in such an environment. Ashford (1986) found that even when people had negative beliefs about goal attainment, they frequently engaged in inquiry strategies. If the information is critical and they can cope with the self-esteem-related costs, individuals have even been shown to seek negative information at the expense of their immediate positive mood (Trobe & Neter, 1994). In higher status identity cultures, where image management concerns are of greater importance, we would not expect to see a person risk the potential "loss of face" from engaging in inquiry strategies to the same degree as in a lower status identity culture. For

instance, in an organization in India, it may not be appropriate to solicit information; thus, a monitoring strategy might be a more preferred form of feedback seeking. Therefore, the following propositions are offered.

*Proposition 11a: Individuals shaped by a lower status identity culture will use more direct-inquiry feedback-seeking strategies.*

*Proposition 11b: Individuals shaped by a higher status identity culture will use more monitoring and indirect-inquiry feedback-seeking strategies.*

In a higher status identity culture, people may be especially reluctant to seek information from a superior because of the earlier proposed costs. Higher-status employees traditionally are more distanced from managers (Earley & Stubblebine, 1989); thus, upward inquiry might not prove appropriate. By extension, individuals will not seek downward inquiry because of the importance of maintaining distance. Therefore, in higher status identity cultures, feedback-seeking behavior may be more lateral. In lower status identity cultures, differentials are not as dramatic, so there should not be as much of an ego threat. Research in the United States has shown the willingness of individuals to solicit feedback from their superiors (Ashford & Tsui, 1991; Callister et al., 1999). Indeed, managers might see such behavior as "assertive" and "competent" (Ashford & Cummings, 1985). Additionally, the value of obtaining information from peers tends to decline over time (Callister et al., 1999; Morrison & Bies, 1991). For these reasons, we propose the following propositions.

*Proposition 12a: Individuals shaped by a higher status identity culture will seek feedback from peers more than from superiors and subordinates.*

*Proposition 12b: Individuals shaped by a lower status identity culture will seek feedback from superiors and subordinates more than from peers.*

## CONCLUSION

We have now reviewed the potential for cultural characteristics to impact the feedback-seeking process. We presented a theory-based

model in which we identified the syndromes of specific-holistic orientation, tolerance for ambiguity, individualism-collectivism, and status identity. We also offered propositions of the potential relevance to feedback-seeking behavior that are rooted in existing cultural contributions (Bond & Smith, 1996), seminal studies (Hofstede, 1980; Triandis, 1988, 1995), and relational issues (Chen et al., 1998; Earley, 1997; Erez & Earley, 1993; Mezias et al., 1999) in the management literature. Although varied constructs of culture have been conceptualized (Schwartz, 1990, 1994; Smith, Dugan, & Trompenaars, 1996) and alternative explanations to culture have been postulated (Peterson & Smith, 1997; Van de Vliert & Van Yperen, 1996), the topology we have developed is an initial attempt to build a model for the specific task of integrating culture and feedback-seeking behavior (Earley & Gibson, 1998; Earley & Singh, 1995; Lytle et al., 1995). In doing so, we follow the call by many to move away from grand theories and to pursue research that is problem focused (Aquino, 1998; Bigley & Pearce, 1998) and in which specific cultural contexts are examined (Osland & Bird, 2000).

With integrative, multinational organizations more prevalent in today's global economy, we need to develop methods to assist culture-spanning managers (Adler, 1991). Understanding culture is important for comprehending differences in individual behavior—one difference being the complicated way information is provided to and sought by organizational members (Klich & Feldman, 1992; Levy et al., 1995; Maurer & Tarulli, 1994; Sedikides, 1993; Swann et al.,

1989; Vancouver & Morrison, 1995). For example, one culture may promote seeking feedback laterally, and another culture may demand feedback seeking only from vertical sources. Galbraith (1977) states that different buffers are necessary in designing a system appropriate for addressing obstacles to effective information processing. Organizational roles integrated across cultures might prove one such challenge, both in how an individual seeks or how the organization provides feedback. We do not claim to be exhaustive in our efforts here. Rather, we seek to inspire future efforts in this potentially rich area.

Figure 1 provides a summary of our discussion. In it we provide a stage model of how culture impacts feedback-seeking behavior. At the left of the figure, research shows how culture affects feedback giving. Here we show the syndromes and propositions we have associated with this antecedent of feedback-seeking behavior. Next, we propose how the tolerance for ambiguity syndrome may moderate the perceived adequacy of the organization's effort. Again, we are not exhaustive here, since in future research scholars may identify other syndromes that also have an effect. Moving to the right, we illustrate in the figure how the syndromes identified might individually impact considerations of feedback-seeking costs, strategies, and source. Although we discussed the syndrome impacts independently, others have found that interactions across dimensions may present a further challenge (Earley et al., 1999; Gudykunst, 1983; Hofstede, 1980; Osland & Bird,

**FIGURE 1**  
**Stage Model of Cross-Cultural Influences on Feedback-Seeking Behavior**

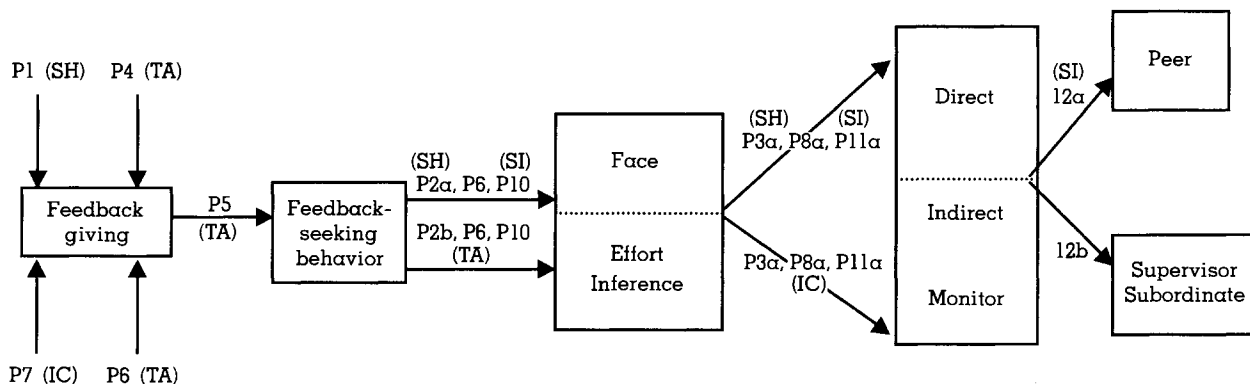

Key: SH = specific-holistic; TA = tolerance for ambiguity; IC = individualism-collectivism; SI = status identity.



2000; Triandis, 1995). Indeed, the multiple propositions on a single arrow suggest these interactions might occur within a stage as well as across stages.

For example, China's high holistic orientation intermingles with its collectivistic characteristics to create a rich, clan. Of interest to us, the group-focused nature combined with overlapping life experiences may create more frequent use of observational or monitoring feedback-seeking strategies. Similarly, the interaction of tolerance for ambiguity and status identity might be significant. Individuals shaped by a lower tolerance for ambiguity culture may be compelled to seek feedback more frequently than individuals from higher tolerance for ambiguity cultures. However, if these same individuals also have high status identity characteristics, they also may not feel compelled to directly ask questions of superiors in the organization. Thus, there may be a tradeoff consideration between desires to reduce uncertainty versus desires to minimize face costs. These complexities represent a challenge for researchers and practitioners. We must be aware that behavior is not only affected by specific differences on a single dimension but is also complicated by interactions across dimensions. Indeed, this is why research efforts have moved toward syndromes as an integrated system of cultural values.

Traditionally, researchers have focused on the impact of individual and cultural differences originating *within* the person. Beyond understanding individual variation in feedback-seeking behavior, we see further challenges arise in attempting to comprehend the dynamics of feedback interactions involving individuals from different cultures. In some disciplines (e.g., communication) attention is shifting to an examination of the impact of differences *between* actors. For example, a recent conflict management study showed how the gender combination (called "gendered transaction") of the supervisor-subordinate dyad moderated ratings of the supervisor (Glomb & Hulin, 1997). Our discussion here is limited, but in future research scholars should investigate the ramifications of a feedback seeker with one cultural profile interacting with a feedback provider with a different cultural profile (what we will call "cultured transactions"). Managers born or trained in a specific-oriented culture may attempt more direct delivery of feedback to employees and

expect their utilization of direct-inquiry feedback-seeking strategies. However, if these employees originate from a holistic-oriented culture, furnishing feedback in this manner and expecting this use of strategies may potentially contribute to misunderstanding or conflict between superiors and subordinates.

In closing, seeking out information in organizational settings assists employees in formulating attitudes and behaviors (Salancik & Pfeffer, 1978). Furthermore, the extent to which individuals adapt and even succeed may depend upon their ability to acquire and use evaluative information. This feedback-seeking activity is not conducted in cognitive isolation but brings with it all the features of the culture from which the organizational member originates. Individuals may obliquely monitor and indirectly or directly inquire to glean informational feedback (Ashford & Cummings, 1983; Herold & Parsons, 1985), and we propose these actions are greatly shaped by culture. Anticipating differences in feedback seeking, effective managers should ready themselves for the task of appropriately providing performance feedback. Developing an understanding of how cultural forces influence the way individuals seek information can help us address these increasing international management concerns. We hope the model and propositions presented here provide a framework and forum for future research.

## REFERENCES

- Ackerman, P. L. 1987. Individual differences in skill learning: An integration of psychometric and information processing perspectives. *Psychological Bulletin*, 102: 3-27.
- Adler, N. J. 1991. *International dimensions of organizational behavior*. Boston: PWS-Kent.
- Adler, N. J., Doktor, R., & Redding, S. G. 1986. From the Atlantic to the Pacific century: Cross cultural management reviewed. *Journal of Management*, 12: 295-318.
- Ammons, R. B. 1956. Effects of knowledge of performance: A survey and tentative theoretical formulation. *Journal of General Psychology*, 54: 279-299.
- Aquino, K. 1998. The effects of ethical climate and the availability of alternatives on the use of deception during negotiation. *International Journal of Conflict Management*, 9: 195-217.
- Arvey, R. D., & Ivancevich, J. M. 1980. Punishment in organizations: A review, propositions, and research suggestions. *Journal of Management Review*, 5: 123-132.
- Ashford, S. J. 1986. Feedback-seeking in individual adapta-

- tion: A resource perspective. *Academy of Management Journal*, 29: 465-487.
- Ashford, S. J., & Cummings, L. L. 1983. Feedback as an individual resource: Personal strategies of creating information. *Organizational Behavior and Human Performance*, 32: 370-398.
- Ashford, S. J., & Cummings, L. L. 1985. Proactive feedback seeking: The instrumental use of the information environment. *Journal of Occupational Psychology*, 58: 67-79.
- Ashford, S. J., & Northcraft, G. B. 1992. Conveying more (or less) than we realize: The role of impression-management in feedback seeking. *Organizational Behavior and Human Decision Processes*, 53: 310-334.
- Ashford, S. J., & Tsui, A. S. 1991. Self-regulation for managerial effectiveness: The role of active feedback seeking. *Academy of Management Journal*, 34: 250-280.
- Balcazar, F., Hopkins, B. L., & Suarez, Y. 1985. A critical, objective review of performance feedback. *Journal of Organizational Behavior Management*, 7: 65-89.
- Bandura, A. 1977. *Social learning theory*. Englewood Cliffs, NJ: Prentice-Hall.
- Bandura, A. 1991. Social cognitive theory of self-regulation. *Organizational Behavior and Human Decision Processes*, 50: 248-287.
- Banfield, E. C. 1958. *The moral basis of backward society*. Glencoe, IL: Free Press.
- Barrett, G. V., & Bass, B. M. 1967. Cross-cultural issues in industrial and organizational psychology. In M. D. Dunnette (Ed.), *Handbook of industrial and organizational psychology*: 1639-1686. Chicago: Rand McNally.
- Berger, C. R. 1979. Beyond initial understanding: Uncertainty, understanding, and the development of interpersonal relationships. In H. Giles & R. N. St. Clair (Eds.), *Language and social psychology*: 122-144. Oxford: Blackwell.
- Bigley, G., & Pearce, J. L. 1998. Straining for shared meaning in organizational science: Problems with trust and distrust. *Academy of Management Review*, 23: 405-421.
- Bloom, A. H. 1981. *The linguistic shape of thought: A study of the impact of language on thinking in the west*. Hillsdale, NJ: Lawrence Erlbaum Associates.
- Bond, M. H. 1986. *The psychology of the Chinese mind*. London: Oxford University Press.
- Bond, M. H., & Smith, P. B. 1996. Cross-cultural social and organizational psychology. *Annual Review of Psychology*, 47: 205-235.
- Boyacigiller, N., Kleinberg, J., Sackmann, S., & Phillips, M. 1996. Conceptualizing culture. In B. J. Punnett & O. Shenkar (Eds.), *Handbook for international management research*: 157-204. New York: Blackwell.
- Brett, J. M., Feldman, D. C., & Weingart, L. R. 1990. Feedback-seeking behavior of new hires and job changers. *Journal of Management*, 16: 737-749.
- Brett, J. M., & Okumura, T. 1998. Inter- and intracultural negotiation: U.S. and Japanese negotiators. *Academy of Management Journal*, 41: 495-510.
- Brockner, J., & Chen, Y. 1996. The moderating roles of self-esteem and self-construal in reaction to a threat to the self: Evidence from the People's Republic of China and the United States. *Journal of Personality and Social Psychology*, 71: 603-615.
- Brown, J. D., & Dutton, K. A. 1995. Truth and consequences: The costs and benefits of accurate self-knowledge. *Personality and Social Psychology Bulletin*, 21: 1288-1296.
- Budner, S. 1962. Intolerance of ambiguity as a personality variable. *Journal of Personality*, 30: 29-50.
- Callister, R. R., Kramer, M. W., & Turban, D. B. 1999. Feedback seeking following career transitions. *Academy of Management Journal*, 42: 429-438.
- Castellan, N. J., Jr., & Swaine, M. 1977. Long term feedback effects in non-metric multiple-cue probability learning. *Behavioral Science*, 22: 116-128.
- Chan, D. K. S., Gelfand, M. J., Triandis, H. C., & Tzeng, O. 1996. Tightness-looseness revisited: Some preliminary analyses in Japan and the United States. *International Journal of Psychology*, 31(1): 1-12.
- Chen, Y. R., Brockner, J., & Katz, T. 1997. *Individual-primacy and collective-primacy as bases for ingroup bias: Evidence from the United States and the People's Republic of China*. Paper presented at the annual meeting of the Academy of Management, Boston.
- Chen, C. C., Chen, X.-P., & Meindl, J. R. 1998. How can cooperation be fostered? The cultural effects of individualism-collectivism. *Academy of Management Review*, 23: 285-304.
- Child, J. 1981. Culture, contingency and capitalism in the cross-national study of organizations. In L. L. Cummings & B. M. Staw (Eds.), *Research in organizational behavior*, vol. 3: 303-356. Greenwich, CT: JAI Press.
- Chinese Culture Connection. 1987. Chinese values and the search for culture-free dimensions of culture. *Journal of Cross-Cultural Psychology*, 18: 143-164.
- Cusella, L. P. 1987. Feedback motivation and performance. In F. M. Jablin, L. L. Putnam, K. H. Robertand, & L. W. Porter (Eds.), *Handbook of organizational communication*: 624-678. Newbury Park, CA: Sage.
- Dawson, J. L. M., Law, H., Leung, A., & Whitney, R. E. 1971. Scaling Chinese traditional-modern attitudes and the GSR measurement of "important" versus "unimportant" Chinese concepts. *Journal of Cross-Cultural Psychology*, 2: 1-27.
- DeVos, G. A. 1990. Self in society: A multilevel, psychocultural analysis. In G. A. DeVos & M. Suarez-Orozco (Eds.), *Status inequality: The self in culture*: 17-74. Newbury Park, CA: Sage.
- DeVos, G. A., & Suarez-Orozco, M. 1990. *Status inequality: The self in culture*. Newbury Park, CA: Sage.
- Earley, P. C. 1986. Trust, perceived importance of praise and criticism, and work performance: An examination of feedback in the United States and England. *Journal of Management*, 12: 457-473.
- Earley, P. C. 1988. Computer-generated performance feedback in the magazine-subscription industry. *Organiza-*

- tional Behavior and Human Decision Processes*, 41: 50-64.
- Earley, P. C. 1989. Social loafing and collectivism. *Administrative Science Quarterly*, 34: 565-581.
- Earley, P. C. 1993. East meets West meets Mideast: Further explorations of collectivistic and individualistic work groups. *Academy of Management Journal*, 36: 319-348.
- Earley, P. C. 1997. *Face, harmony and social structure*. New York: Oxford University Press.
- Earley, P. C., & Erez, M. 1997. *New perspectives on international industrial/organization psychology*. San Francisco: New Lexington Press.
- Earley, P. C., & Gibson, C. B. 1998. Taking stock in our progress on individualism-collectivism: 100 years of solidarity and community. *Journal of Management*, 24: 265-304.
- Earley, P. C., Gibson, C. B., & Chen, C. 1999. How did I do versus how did we do? Intercultural contrasts of performance feedback search and self-efficacy in China, Czechoslovakia, and the United States. *Journal of Cross-Cultural Psychology*, 30: 594-619.
- Earley, P. C., & Singh, H. 1995. International and intercultural management research: What's next? *Academy of Management Journal*, 38: 327-340.
- Earley, P. C., & Stubblebine, P. 1989. Intercultural assessment of performance feedback. *Group and Organizational Studies*, 14: 161-181.
- Edwards, J. R. 1995. Alternatives to difference sources as dependent variables in the study of congruence in organizational research. *Organizational Behavior and Human Decision Processes*, 64: 307-324.
- Erez, M., & Earley, P. C. 1993. *Culture, self-identity, and work*. New York: Oxford University Press.
- Fedor, D. B., Rensvold, R. B., & Adams, S. M. 1992. An investigation of factors expected to affect feedback seeking: A longitudinal field study. *Personnel Psychology*, 45: 779-805.
- Feldman, D. C., & Brett, J. M. 1983. Coping with new jobs: A comparative study of new hires and job changers. *Academy of Management Journal*, 26: 258-272.
- Festinger, L. 1954. A theory of social comparison processes. *Human Relations*, 7: 117-140.
- Festinger, L. 1957. *A theory of cognitive dissonance*. Palo Alto, CA: Stanford University Press.
- Funderburg, S. A., & Levy, P. E. 1997. The influence of individual and contextual variables on 360-degree feedback system attitudes. *Group and Organization Management*, 22: 210-235.
- Galbraith, J. R. 1977. *Organization design*. Reading, MA: Addison-Wesley.
- Ganzach, Y. 1994. Feedback representation and prediction strategies. *Organizational Behavior and Human Decision Processes*, 59: 391-409.
- Gibson, C. B. 1999. Do they do what they believe they can? Group efficacy and group effectiveness across task and cultures. *Academy of Management Journal*, 42: 138-152.
- Glomb, T. M., & Hulin, C. L. 1997. Anger and gender effects in observed supervisor-subordinate dyadic interactions. *Organizational Behavior and Human Decision Processes*, 72: 281-307.
- Goffman, E. 1959. *The presentation of self in everyday life*. Garden City, NY: Doubleday.
- Goltz, S. M., Citera, M., Jensen, M., Favero, J., & Komaki, J. L. 1989. Individual feedback: Does it enhance effects of group feedback? *Journal of Organizational Behavior Management*, 10(2): 77-92.
- Greenwald, G., & Pratkanis, A. R. 1984. The self. In R. S. Wyer & T. K. Srull (Eds.), *Handbook of social cognition*: 129-178. Hillsdale, NJ: Lawrence Erlbaum Associates.
- Gruder, C. L. 1977. Choice of comparison persons in evaluating oneself. In J. M. Suls & R. C. Miller (Eds.), *Social comparison processes: Theoretical and empirical perspectives*: 21-42. Washington, DC: Hemisphere.
- Gruenfeld, L. W., & MacEachron, A. E. 1975. A cross-national study of cognitive style among managers and technicians. *International Journal of Psychology*, 10: 27-55.
- Gudykunst, W. B. 1983. Uncertainty reduction and predictability of behavior in low- and high-context cultures. *Communication Quarterly*, 33: 236-251.
- Gudykunst, W. B., Matsumoto, Y., Ting-Toomey, S., Nishida, T., Kim, K., & Heyman, S. 1996. The influence of cultural individualism-collectivism, self construals, and individual values on communication styles across cultures. *Human Communication Research*, 22: 510-543.
- Gupta, A. K., Govindarajan, V., & Malhotra, A. 1996. Feedback-seeking behavior of subsidiary presidents in multinational corporations. *Academy of Management Proceedings*: 151-155.
- Guzzo, R. A., Jette, R. D., & Katzell, R. A. 1985. The effects of psychologically based intervention programs on worker productivity: A meta-analysis. *Personnel Psychology*, 38: 275-291.
- Hackman, J. R. 1977. Work design. In J. R. Hackman & J. L. Suttle (Eds.), *Improving life at work*. Glenview, IL: Scott, Foresman.
- Haire, M., Ghiselli, E. E., & Porter, L. W. 1966. *Managerial thinking: An international study*. New York: Wiley.
- Hall, E. T. 1976. *Beyond culture*. New York: Doubleday.
- Herold, D. M., & Greller, M. M. 1977. Feedback: The definition of a construct. *Academy of Management Journal*, 20: 142-147.
- Herold, D. M., & Parsons, C. K. 1985. Assessing the feedback environment in work organizations: Development of the job feedback survey. *Journal of Applied Psychology*, 70: 290-309.
- Hofstede, G. 1980. *Culture's consequences: International differences in work-related values*. Newbury Park, CA: Sage.
- House, R., Rousseau, D. M., & Thomas-Hunt, M. 1995. The meso paradigm: A framework for the integration of micro and macro organizational behavior. In L. L. Cummings & B. M. Staw (Eds.), *Research in organizational behavior*, vol. 17: 71-114. Greenwich, CT: JAI Press.

- Hui, C. H. 1988. Measurement of individualism-collectivism. *Journal of Research in Personality*, 22: 17-36.
- Ilgen, D. R., Fisher, C. D., & Taylor, M. S. 1979. Consequences of individual feedback on behavior in organizations. *Journal of Applied Psychology*, 64: 349-371.
- Johnson, J. D. 1996. *Information seeking: An organizational dilemma*. Westport, CT: Quorum.
- Katakis, C. D. 1976. An exploratory multilevel attempt to investigate interpersonal and intrapersonal patterns of 20 Athenian families. *Mental Health and Society*, 3: 1-9.
- Kedia, B. L., & Bhagat, R. S. 1988. Cultural constraints on transfer of technology across nations: Implications for research in international and comparative management. *Academy of Management Review*, 13: 559-571.
- Klein, K. J., Dansereau, F., & Hall, R. J. 1994. Levels issues in theory development, data collection, and analysis. *Academy of Management Review*, 19: 195-229.
- Klich, N. R., & Feldman, D. C. 1992. The role of approval and achievement needs in feedback seeking behavior. *Journal of Managerial Issues*, 4: 554-570.
- Kluckhohn, F., & Strodtbeck, F. 1961. *Variations in value orientations*. Evanston, IL: Row, Peterson.
- Kluger, A. N., & DeNisi, A. 1996. The effects of feedback interventions on performance: A historical review, a meta-analysis, and a preliminary feedback intervention theory. *Psychological Bulletin*, 119: 254-284.
- Koestner, R., Zuckerman, M., & Koestner, J. 1987. Praise, involvement, and intrinsic motivation. *Journal of Personality and Social Psychology*, 53: 383-390.
- Kramer, M. W. 1994. Uncertainty reduction during job transitions: An exploratory study of the communication experiences of newcomers and transferees. *Management Communication Quarterly*, 7: 384-412.
- Larson, J. R., Jr. 1989. The dynamic interplay between employees' feedback-seeking strategies and supervisors' delivery of performance feedback. *Academy of Management Review*, 14: 408-422.
- Larson, J. R., Jr., & Callahan, C. 1990. Performance monitoring: How it affects work productivity. *Journal of Applied Psychology*, 75: 530-538.
- Lee, J. W., & Yates, J. F. 1992. How quantity judgment changes as the number of cues increases: An analytical framework and review. *Psychological Bulletin*, 107: 34-47.
- Leung, K. 1997. Negotiation and reward associations across cultures. In P. C. Earley & M. Erez (Eds.), *New perspectives on international industrial/organizational psychology*: 640-675. San Francisco: Jossey-Bass.
- Levy, P. E., Albright, M. D., Cawley, B. D., & Williams, J. R. 1995. Situational and individual determinants of feedback seeking: A closer look at the process. *Organizational Behavior and Human Decision Processes*, 62: 23-37.
- Lewicki, R. J., McAllister, D. J., & Bies, R. J. 1998. Trust and distrust: New relationships and realities. *Academy of Management Review*, 23: 438-458.
- Locke, E. A. 1980. Latham vs. Komaki: A tale of two paradigms. *Journal of Applied Psychology*, 65: 16-23.
- Locke, E. A., & Latham, G. P. 1990. *A theory of goal setting and task performance*. Englewood Cliffs, NJ: Prentice-Hall.
- London, M. 1997. *Job feedback: Giving, seeking, and using feedback for performance improvement*. Mahwah, NJ: Lawrence Erlbaum Associates.
- Lytle, A. L., Brett, J. M., Barsness, Z. I., Tinsley, C. H., & Janssens, M. 1995. A paradigm for confirmatory cross cultural research in organizational behavior. In L. L. Cummings & B. M. Staw (Eds.), *Research in organizational behavior*, vol. 17: 167-214. Greenwich, CT: JAI Press.
- Markus, H. R., & Kitayama, S. 1991. Culture and the self: Implications for cognition, emotion, and motivation. *Psychological Review*, 98: 224-253.
- Maurer, T. J., & Tarulli, B. A. 1994. Investigation of perceived environment, perceived outcome, and person variables in relationship to voluntary development activity of employees. *Journal of Applied Psychology*, 79: 3-14.
- Mezias, S. J., Chen, Y. R., & Murphy, P. 1999. "Toto, I don't think we're in Kansas anymore." Some footnotes to cross-cultural research. *Journal of Management Inquiry*, 8: 323-333.
- Miller, V. D., & Jablin, F. M. 1991. Information seeking during organizational entry: Influences, tactics, and a model of the process. *Academy of Management Review*, 16: 92-120.
- Morris, C. 1956. *Varieties of human value*. Chicago: University of Chicago Press.
- Morrison, E. W. 1993. Newcomer information seeking: Exploring types, modes, sources, and outcomes. *Academy of Management Journal*, 36: 557-589.
- Morrison, E. W. 1995. Invited reactions: Comments on Madzar's article. *Human Resource Development Quarterly*, 6: 351-353.
- Morrison, E. W., & Bies, R. J. 1991. Impression management in the feedback-seeking process: A literature review and research agenda. *Academy of Management Review*, 16: 522-541.
- Morrison, E. W., & Cummings, L. L. 1992. The impact of feedback diagnosticity and performance expectations on feedback seeking behavior. *Human Performance*, 5: 251-264.
- Northcraft, G. B., & Ashford, S. J. 1990. The preservation of self in everyday life: The effects of performance expectations and feedback context on feedback inquiry. *Organizational Behavior and Human Decision Processes*, 47: 42-64.
- Norton, R. W. 1975. Measurement of ambiguity tolerance. *Journal of Personality Assessment*, 39: 607-619.
- O'Reilly, C. A., III. 1983. The use of information in organizational decision-making: A model and some propositions. In L. L. Cummings & B. M. Staw (Ed.), *Research in organizational behavior*, vol. 5: 109-139. Greenwich, CT: JAI Press.
- Osland, J. S., & Bird, A. 2000. Beyond sophisticated stereotyp-

- ing: A contextual model of cultural sensemaking. *Academy of Management Executive*, 14(1): 65-79.
- Ostroff, C., & Kozlowski, S. W. 1992. Organizational socialization as a learning process: The role of information acquisition. *Personnel Psychology*, 45: 849-874.
- Parsons, T., & Shils, E. 1951. *Toward a general theory of action*. Cambridge, MA: Harvard University Press.
- Pearce, J. L., & Porter, L. W. 1986. Employee responses to formal performance appraisal feedback. *Journal of Applied Psychology*, 71: 211-218.
- Pelto, P. J. 1968. The difference between "tight" and "loose" societies. *Transaction*, April: 37-40.
- Pepitone, A., & Triandis, H. C. 1988. On the universality of social psychological theories. *Journal of Cross-Cultural Psychology*, 18: 471-498.
- Peterson, M. F., & Smith, P. B. 1997. Does national culture or ambient temperature explain cross-national differences in role stress? No sweat. *Academy of Management Journal*, 40: 930-946.
- Podsakoff, P. M., & Farh, J. H. 1989. Effects of feedback sign and credibility on goal setting and task performance. *Organizational Behavior and Human Decision Processes*, 44: 45-67.
- Pritchard, R. D., Jones, S. D., Roth, P. L., Stuebing, K. K., & Edeberg, S. E. 1988. Effects of group feedback, goal setting, and incentives on organizational productivity. *Journal of Applied Psychology*, 73: 337-358.
- Prue, D. M., & Fairbank, J. A. 1981. Performance feedback in organizational behavior management: A review. *Journal of Organizational Behavior Management*, 3: 1-16.
- Redding, S. G. 1980. Cognition as an aspect of culture and its relation to management processes: An explanatory view of the Chinese case. *Journal of Management Studies*, 17: 127-148.
- Ronen, S., & Shenkar, O. 1985. Clustering countries on attitudinal dimensions: A review and synthesis. *Academy of Management Review*, 10: 435-454.
- Salancik, G. R., & Pfeffer, J. 1978. A social information processing approach to job attitudes and task design. *Administrative Science Quarterly*, 23: 224-253.
- Salmoni, A. W., Schmidt, R. A., & Walter, C. B. 1984. Knowledge of results and motor learning: A review and critical reappraisal. *Psychological Bulletin*, 95: 355-386.
- Sarnoff, I. 1966. *Society with tears*. Secaucus, NJ: Citadel Press.
- Schermerhorn, J. R., & Bond, M. H. 1991. Upward and downward influence tactics in managerial networks: A comparative study of Hong Kong Chinese and Americans. *Asia Pacific Journal of Management*, 8(2): 147-158.
- Schwartz, S. H. 1990. Individualism-collectivism: Critique and proposed refinements. *Journal of Cross-Cultural Psychology*, 21: 139-157.
- Schwartz, S. H. 1992. Universals in the content and structure of values: Theoretical advances and empirical tests in two countries. In L. Berkowitz (Ed.), *Advances in experimental social psychology*: 1-65. San Diego: Academic Press.
- Schwartz, S. H. 1994. Cultural dimensions of values: Towards an understanding of national differences. In U. Kim, H. C. Triandis, & G. Yoon (Eds.), *Individualism and collectivism: Theoretical and methodological issues*: 85-119. Newbury Park, CA: Sage.
- Sedikides, C. 1993. Assessment, enhancement, and verification determinants of self-evaluation processes. *Journal of Personality and Social Psychology*, 65: 317-338.
- Shackleton, V. J., & Ali, A. H. 1990. Work-related values of managers: A test of the Hofstede model. *Journal of Cross-Cultural Psychology*, 21: 109-118.
- Singelis, T. M., & Brown, W. J. 1995. Culture, self, and collectivist communication: Linking culture to individual behavior. *Human Communication Research*, 21: 354-389.
- Smith, P. B., Dugan, S., & Trompenaars, F. 1996. National culture and managerial values: A dimensional analysis across 43 nations. *Journal of Cross-Cultural Psychology*, 27: 231-264.
- Stajkovic, A. D., & Luthans, F. 1997. A meta-analysis of the effects of organizational behavior modification on task performance: 1975-1995. *Academy of Management Journal*, 40: 1122-1149.
- Suls, J., & Wills, T. A. 1991. *Social comparison: Contemporary theory and research*. Hillsdale, NJ: Lawrence Erlbaum Associates.
- Swann, W. B., Pelham, B. W., & Krull, D. S. 1989. Agreeable fancy or disagreeable truth? Reconciling self-enhancement and self-verification. *Journal of Personality and Social Psychology*, 57: 782-791.
- Swann, W. B., & Read, S. I. 1981. Acquiring self-knowledge: The search for feedback that fits. *Journal of Personality and Social Psychology*, 41: 1119-1128.
- Swann, W. B., Stein-Seroussi, A., & Giesler, R. B. 1992. Why people self-verify. *Journal of Personality and Social Psychology*, 62: 392-401.
- Tajfel, H., & Turner, J. C. 1986. The social identity theory of intergroup behavior. In S. Worchel & W. G. Austin (Eds.), *Psychology of intergroup relations*: 7-24. Chicago: Nelson-Hall.
- Taylor, M. S., Fisher, C. D., & Ilgen, D. R. 1984. Individuals' reactions to performance feedback in organizations: A control theory perspective. In K. M. Rowland & G. R. Ferris (Eds.), *Research in personnel and human resources management*, vol. 2: 81-124. Greenwich, CT: JAI Press.
- Triandis, H. C. 1982. Dimensions of cultural variations as parameters of organizational theories. *International Studies of Management and Organization*, 12(4): 139-169.
- Triandis, H. C. 1988. Collectivism v. individualism: A reconceptualization of a basic concept of cross-cultural psychology. In G. K. Verma & C. Bagley (Eds.), *Cross-cultural studies of personality, attitudes and cognition*: 60-95. London: Macmillan.
- Triandis, H. C. 1989. The self and social behavior in differing cultural contexts. *Psychological Review*, 96: 506-520.

- Triandis, H. C. 1990. Cross-cultural studies of individualism and collectivism. In J. J. Berman (Ed.), *Nebraska symposium on motivation*, vol. 37: 41-133. Lincoln: University of Nebraska Press.
- Triandis, H. C. 1995. *Individualism and collectivism*. Boulder, CO: Westview.
- Triandis, H. C. 1996. The psychological measurement of cultural syndromes. *American Psychologist*, 51: 407-415.
- Triandis, H. C., & Gelfand, M. J. 1998. Converging measurement of horizontal and vertical individualism and collectivism. *Journal of Personality and Social Psychology*, 74: 118-128.
- Trompenaars, F. 1993. *Riding the waves of culture: Understanding diversity in global business*. New York: Irwin.
- Trompenaars, A., & Hampden-Turner, C. 1998. *Riding the waves of culture: Understanding cultural diversity in global business* (2nd ed.). New York: McGraw-Hill.
- Trope, Y. 1975. Seeking information about one's own ability as a determinant of choice among tasks. *Journal of Personality and Social Psychology*, 32: 1004-1013.
- Trope, Y. 1980. Self-assessment, self-enhancement and task performance. *Journal of Experimental Social Psychology*, 16: 116-129.
- Trope, Y. 1982. Self-assessment and task performance. *Journal of Experimental Social Psychology*, 18: 201-215.
- Trope, Y., & Neter, E. 1994. Reconciling competing motives in self-evaluation: The role of self-control in feedback seeking. *Journal of Personality and Social Psychology*, 66: 646-657.
- Tsui, A., Ashford, S., St. Clair, L., & Xin, K. 1995. Dealing with discrepant expectations: Response strategy and managerial effectiveness. *Academy of Management Journal*, 38: 1515-1543.
- Vancouver, J. B., & Morrison, E. W. 1995. Feedback inquiry: The effect of source attributes and individual differences. *Organizational Behavior and Human Decision Processes*, 62: 276-285.
- Van de Vliert, E., & Van Yperen, N. W. 1996. Why cross-national difference in role overload? Don't overlook ambient temperature. *Academy of Management Journal*, 39: 986-1004.
- Vroom, V. H. 1964. *Work and motivation*. New York: Wiley.
- Waldersee, R., & Luthans, F. 1994. The impact of positive and corrective feedback on customer service performance. *Journal of Organizational Behavior*, 15: 83-95.
- Wayne, S. J., & Liden, R. C. 1995. Effects of impression management on performance ratings: A longitudinal study. *Academy of Management Journal*, 38: 232-260.
- Wheeler, L. 1966. Motivation as a determinant of upward comparison. *Journal of Experimental Psychology*, 2: 27-31.
- Whyte, W. F. 1963. Culture, industrial relations and economic development: The case of Peru. *Industrial and Labor Relations Review*, 5: 110-117.
- Witkin, H. A., & Berry, J. W. 1975. Psychological differentiation in cross-cultural perspective. *Journal of Cross-Cultural Psychology*, 6: 4-87.
- Witkin, H. A., Goodenough, D. R., & Oltman, P. K. 1979. Psychological differentiation: Current status. *Journal of Personality and Social Psychology*, 37: 1127-1145.
- Wood, J. V. 1989. Theory and research concerning social comparisons of personal attributes. *Psychological Bulletin*, 106: 231-248.
- Yang, D. S., & Ho, D. 1988. The role of yuan in Chinese social life: A conceptual and empirical analysis. In A. C. Paranjpe, D. Ho, & R. W. Rieber (Eds.), *Asian contributions to psychology*: 263-281. New York: Praeger.
- Yang, E. A., & Tsai, G. Y. 1996. *A case of researchers' journey into home culture: Interaction of culture and method through the medium of researchers*. Paper presented at the annual meeting of the Academy of Management, Cincinnati.

**Mary F. Sully de Luque** is a postdoctoral fellow and senior GLOBE associate at the University of Pennsylvania. She graduated in August 2000 from her Ph.D. program in organizational behavior at the University of Nebraska. Her research interests include cross-cultural research focusing on leadership, as well as information-seeking behavior.

**Steven M. Sommer** is an associate professor of management at the University of Nebraska. He received his Ph.D. from the University of California at Irvine. His primary research interest is how informal competition among individuals affects performance and how to manage such processes without damaging interpersonal relations. Related areas include information seeking for self-evaluations, social support, workplace climate, and the application of organizational behavior theories across cultures.