

The impact of post-transcriptional regulation in the p53 network

Justin A. Freeman and Joaquin M. Espinosa

Advance Access publication date 14 December 2012

Abstract

The p53 transcription factor regulates the synthesis of mRNAs encoding proteins involved in diverse cellular stress responses such as cell-cycle arrest, apoptosis, autophagy and senescence. In this review, we discuss how these mRNAs are concurrently regulated at the post-transcriptional level by microRNAs (miRNAs) and RNA-binding proteins (RBPs), which consequently modify the p53 transcriptional program in a cell type- and stimulus-specific manner. We also discuss the action of specific miRNAs and RBPs that are direct transcriptional targets of p53 and how they act coordinately with protein-coding p53 target genes to orchestrate p53-dependent cellular responses.

Keywords: p53; post-transcriptional regulation; RNA-binding proteins; miRNA

INTRODUCTION

The advent of cancer genomics and the sequencing of hundreds of cancer exomes have fully cemented the notion that *TP53* is the most commonly mutated tumor suppressor gene in human cancer [1]. However, after more than three decades of p53 research, much still remains to be understood about this tumor suppressor. In particular, two questions loom large in the field.

How exactly does p53 suppress oncogenesis?

Despite the unequivocal role of p53 in mediating cell-cycle arrest and apoptosis, it is still debated whether these pathways account for its widespread tumor suppressive action. In fact, recent evidence indicates that p53 may stall tumor growth via other, less-characterized cellular functions [2, 3]. The fact that p53 acts as a signaling hub, integrating inputs from multiple upstream pathways and in turn radiating signals to diverse effector pathways makes p53 a highly pleiotropic factor [4]. Thus, it is possible that p53 exerts its tumor suppressive function not by a single universal mechanism, but rather through

context-dependent mechanisms in different tissues of origin or during different stages of cancer development.

How might the p53 network be harnessed for cancer therapeutics?

The recent development of small molecules targeting the p53 repressors MDM2 and MDM4, as well as molecules seemingly restoring the wild-type conformation of mutant p53, has generated much momentum in the field of p53-based therapies [5]. However, as these molecules enter clinical trials, their efficacy will be limited a priori by the fact that we do not understand how the cellular response to p53 activation is defined. Once again, the pleiotropic character of p53 is manifested by well-documented cell type-specific responses to these novel agents, which induce cell death only in select cell types [6–9].

Thus, deciphering the molecular mechanisms generating pleiotropy within the p53 network will not only advance our understanding of p53 function as a tumor suppressor but will also aid in the design of p53-based therapies. Here, we explore how

Corresponding author: Joaquin M. Espinosa, HHMI - University of Colorado at Boulder, 347 UCB, Boulder, CO 80309. Tel: 303 735 6610; E-mail: joaquin.espinosa@colorado.edu

Justin A. Freeman completed undergraduate degrees in Information Systems from The University of Texas at Austin and in Ecology and Evolutionary Biology from the University of Colorado at Boulder. He currently performs bioinformatics analysis in support of a wide range of high-throughput experiments.

Joaquin M. Espinosa is an associate professor of Molecular, Cellular and Developmental Biology at the University of Colorado at Boulder and an HHMI Early Career Scientist. His research focuses on the regulation of gene networks in the context of cancer biology.

post-transcriptional regulatory mechanisms contribute to this pleiotropy. First, we illustrate how microRNAs (miRNAs) and RNA-binding proteins (RBPs) moderate the p53 transcriptional program by targeting key mRNAs within the network. Second, we highlight examples of miRNAs and RBPs whose levels of expression are upregulated by p53 itself. Finally, we demonstrate how p53-dependent cellular responses are orchestrated by the combined action of p53 transactivation within the nucleus and post-transcriptional regulation in the cytoplasm. Throughout the review we will emphasize how these mechanisms create regulatory diversity within the network by acting in a cell type- and stimulus-specific manner.

THE REPRESSIVE EFFECTS OF miRNAs ON p53 TARGET GENE EXPRESSION

Upon activation by diverse stress stimuli, p53 activates transcription of hundreds of protein-coding target genes via direct binding to nearby p53 response elements (p53REs) and recruitment of transcriptional co-activators [10–15]. However, the p53 transcriptional program can be strongly modified by miRNAs. miRNAs are ~21-nucleotide sequences which target mRNAs containing sequences complementary to their 5'-seed regions. miRNA targeting of mRNA has been reviewed excellently elsewhere [16]. By incorporating miRNAs into the p53 regulatory framework, the net effect of p53 activation can be modulated in a context-dependent manner by negative regulation at the post-transcriptional level, moderating what would otherwise be a much greater impact on protein expression of p53 target genes. Therefore, this finely tuned regulatory response has a key role in managing the phenotypic outcomes in response to p53 activation.

p21 (CDKN1A) is a well-characterized p53 target gene and key mediator of p53-dependent cell-cycle arrest [17–19]. p21 works as a cyclin-dependent kinase (CDK) inhibitor, associating with and inhibiting various cyclin-CDK complexes [19, 20]. p21 mRNA expression is regulated by a myriad of post-transcriptional regulators, including several miRNAs (Figure 1). For instance, miRNAs from the miR-17-92 cluster, an oncogenic cluster of six miRNAs on chromosome 13, bind the p21 mRNA 3'-untranslated region (3'UTR) and promote p21 mRNA degradation [21]. Overexpression of

members of the miR-17-92 cluster and its paralog, miR-106b-25 has been implicated in a wide range of cancers, including retinoblastomas, B-cell lymphomas, neuroblastomas and osteosarcomas [21–24].

The p21 mRNA is also targeted by miR-663, which provides an example of how miRNAs can regulate the p53 network in a context-dependent fashion (Figure 1). miR-663 was first characterized as a tumor suppressor in gastric cancer, where it is commonly downregulated [25]; however, it was later defined as an oncogene in nasopharyngeal carcinoma (NPC), where it is commonly overexpressed [26]. miR-663 was found to be required for proliferation of NPC cells *in vitro* and growth of NPC xenografts in nude mice. Mechanistically, miR-663 functions as an oncogene partly by repressing p21 and promoting the G₁/S transition [26].

Viral infection provides another example of context-dependent post-transcriptional modulation of the p53 program, as exemplified by miR-K1, one of 12 miRNAs encoded by the Kaposi's sarcoma-associated herpesvirus (KSHV) genome [27]. miR-K1 represses p21 but not other p53 target genes such as MDM2 and TP53I3 (PIG3), blocking p21-induced cell-cycle arrest in several cell types. Thus, KSHV-infected cells would display an impaired p53-dependent cell-cycle arrest response as compared with non-infected cells.

Pro-apoptotic p53 targets are also subject to miRNA-driven repression. p53 induces apoptosis via transactivation of key genes in the intrinsic and extrinsic apoptotic pathways [28]. p53 upregulated modulator of apoptosis (PUMA, BBC3) is a key mediator of p53-induced apoptosis residing in the intrinsic pathway [29, 30]. PUMA activates the pore-forming proteins BAX/BAK via direct binding to BAX/BAK and/or inhibition of pro-survival BCL2 family members [28]. The PUMA mRNA is targeted by miR-221/222 (Figure 1) [31]. These two miRNAs, which share a conserved seed sequence, are commonly overexpressed in epithelial cancers. Inhibition of these miRNAs relieves their downregulation of PUMA and leads to activation of BAX and the intrinsic apoptotic pathway, resulting in increased cell death [31, 32]. Additionally, miR-221/222 have some regulatory effect on the extrinsic apoptotic pathway. Upregulation of these miRNAs confers resistance to TRAIL-mediated extrinsic apoptotic pathway activation in non-small cell lung cancers (NSCLC) and hepatocellular carcinomas (HCC) [33]. This phenotype is due to

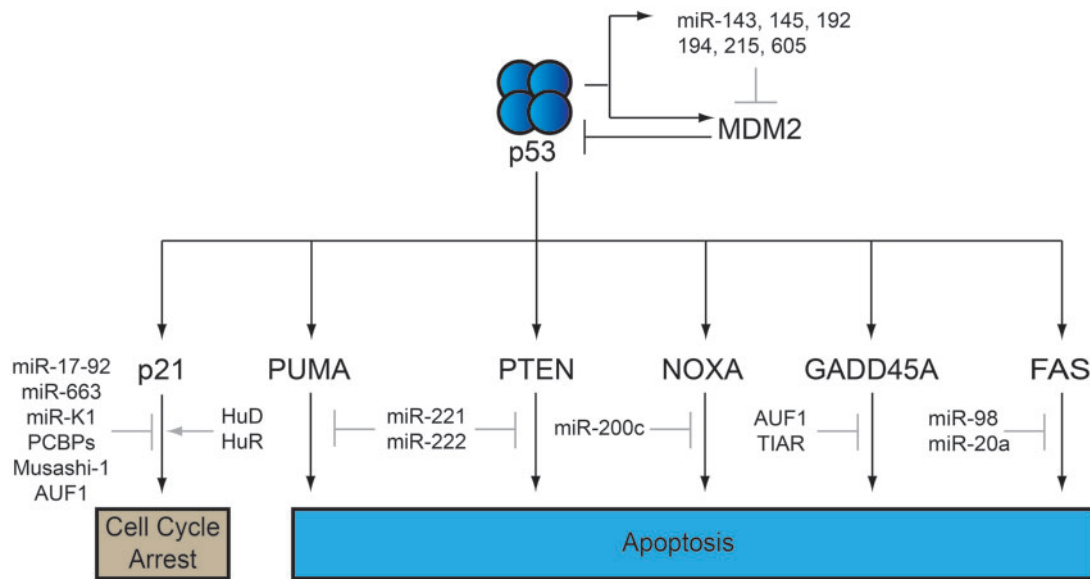

Figure 1: Post-transcriptional regulation of p53 target genes. miRNAs and RBPs work to enhance or repress the expression of p53 target protein-coding genes. This regulatory input influences the phenotypic outcome of p53 activation.

downregulation of the mRNA of two additional miR-221/222 targets—PTEN and TIMP3. PTEN is also a direct p53 transcriptional target. The Croce group showed that both PTEN and TIMP3 expression levels correlate inversely with miR-221/222 expression *in vitro* and *in vivo*. In NSCLC and HCC cell lines, TRAIL resistance correlates positively with miR-221/222 expression, and overexpression of PTEN and TIMP3 or knock-down of miR-221/222 confers increased TRAIL sensitivity [33]. Thus, by targeting the mRNA of three tumor suppressors (PUMA, PTEN and TIMP3), two of which (PUMA and PTEN) are direct p53 transcriptional targets, miR-221/222 are able to post-transcriptionally counteract pro-apoptotic signaling within the p53 network (Figure 1).

NOXA is also a p53 transcriptional target concurrently regulated by miRNAs in cell type-specific fashion. An unbiased screen for miRNAs targeting the 3'-UTR of NOXA led to the identification of miR-200c as a potent repressor of NOXA expression. Interestingly, expression levels of miR-200c vary as much as 200-fold across cancer cell types, with the concurrent inverse correlation in basal NOXA expression [34].

p53 induces the extrinsic apoptotic pathway via transactivation of the death receptors FAS, DR5 and DR4 [35–37]. The FAS mRNA is targeted by let-7/miR-98 and miR-20a (Figure 1) [24, 38]. Bioinformatics analysis predicts that miR-98 targets a

conserved sequence in the FAS 3'-UTR. Indeed, ectopic expression of miR-98 leads to FAS downregulation and a decrease in FasL-induced apoptosis [38]. FAS-repression by miR-20a was shown to play a key role in the survival of metastatic osteosarcoma cells in the FasL+ environment of the lung, a common site of metastasis for bone cancers [24]. Comparison of non-metastatic versus metastatic osteosarcoma cell lines revealed that the miR-20a expression is higher in the latter. Furthermore, miR-20a expression correlates inversely with FAS expression in patient-derived tumor samples and overexpression of miR-20a represses FAS expression and reduces sensitivity to FasL. Importantly, inhibition of miR-20a activity significantly reduces the metastatic potential of osteosarcoma cells, purportedly by restoring sensitivity of FasL in the lung microenvironment [24].

In sum, these examples demonstrate how various p53 targets are co-regulated, often drastically, at the post-transcriptional level by miRNAs in a context-dependent fashion.

THE ROLE OF miRNAs IN THE p53-MDM2 FEEDBACK LOOP

The E3 ubiquitin ligase MDM2 is a key repressor of p53 activity by a triple mechanism: it masks the p53 transactivation domain, shuttles p53 out of the nucleus and targets it for degradation [39–42]. MDM2

is a p53 transcriptional target, thus creating a negative feedback loop that keeps p53 levels and activity under tight control. Multiple miRNAs have been shown to alter this regulatory circuit by targeting the MDM2 mRNA, thus diminishing the amount of MDM2 protein produced in response to p53 activation and allowing increased p53 activity in cells. These miRNAs include the miR-143–145 cluster, miR-192, 194, 215 and 605 (Figure 1). Expression of all these miRNAs is upregulated by p53 either via direct transactivation or, in the case of miR-143–145, at the level of processing [43–46]. Thus, p53 upregulates both its own repressor and several negative regulators of that repressor, thereby creating a positive feedback loop to enhance its own expression levels and activity. Interestingly, the tissue- and cancer-specific patterns of expression of these miRNAs may create pleiotropy by modulating the extent of p53 activation in response to natural stress stimuli or pharmacological agents. For example, repression of the miR-143–145 cluster is common in head and neck squamous cell carcinomas (HNSCC), which causes high MDM2 levels and correlates with poor grade [44]. Since the cellular response to MDM2 inhibitors may be determined in part by the expression levels of MDM2 [6], miRNAs targeting MDM2 may affect the performance of these compounds in the clinic. In fact, the impact of miRNAs on the efficacy of non-genotoxic MDM2 inhibitors has been demonstrated for miR-192, 194 and 215, which are commonly repressed in multiple myeloma (MM) cells, as their re-expression in p53 wild-type MM cells leads to increased sensitivity to the MDM2 inhibitor MI-129 both *in vitro* and *in vivo* [45].

THE ROLE OF RBPs IN REGULATING STABILITY AND TRANSLATION OF p53 TARGET mRNAs

In addition to the action of miRNAs, the p53 transcriptional program is also co-regulated, both negatively and positively, by RBPs that control the stability and translation of mRNAs induced by p53.

p21 provides a prime example of this type of regulation (Figure 1). The interplay between p21 and its RBPs, copious upstream effectors and even between the RBPs themselves provides a complex web of finely tuned positive and negative feedback. RBPs with diverse RNA recognition motifs bind

p21 mRNA, regulating stability of the transcript. Some RBPs antagonize the p21-activating signal of p53, whereas others amplify the signal by providing enhanced mRNA transcript stability. Among RBPs that counteract p53-dependent upregulation of p21 are the Poly(C)-binding proteins (PCBPs). PCBP family members, including PCBP1, PCBP2, PCBP4 and hnRNP K, downregulate p21 by binding to CU-rich regions of its 3'-UTR [47]. Although transcription from the PCBP4 locus can be induced by DNA damage in a p53-dependent manner, PCBP4's regulation of p21 occurs in a p53-independent manner [47]. RBPs can also affect mRNA translation. The RBP Musashi-1 binds the p21 3'-UTR to inhibit its translation [48]. Ectopic expression of Musashi-1 correlates with oncogenesis, whereas siRNA-mediated ablation of Musashi-1 coincides with tumor regression and cancer cell growth arrest in mouse xenografts of human colorectal cancer origin [49, 50].

RBPs can also exert positive effects on mRNA expression. HuD and HuR, two members of the Elav-like protein family, promote p21 mRNA transcript stability via binding to an AU-rich element (ARE) in the p21 3'-UTR, thereby upregulating p21 expression [51]. HuR also enhances translation of the p53 mRNA, further amplifying the p53/p21 axis [52]. HuR action can be antagonized by AUF1 (Heterogeneous Nuclear Ribonucleoprotein D) which binds to a different element in the p21 3'-UTR and leads to p21 mRNA instability [53]. Interestingly, cyclin D1 is regulated in the opposite fashion by HuR and AUF1. DNA damage by UVC has opposite effects on p21 and cyclin D1 mRNA expression, leading to p21 upregulation and cyclin D1 repression, thus enforcing G₁/S arrest. Importantly, the effects of UVC correlate with the binding of HuR and AUF1 to these mRNAs: HuR–p21 mRNA associations increase and HuR–cyclin D1 mRNA associations decrease with UVC. In contrast, AUF1–p21 mRNA associations are reduced and AUF1–cyclin D1 mRNA complexes are elevated following UVC treatment [53]. HuR and AUF1 also bind the mRNA of 14-3-3 σ (SFN), a p53 target gene involved in G₂/M cell-cycle arrest, but the functional relevance of this binding has not yet been explored [53].

GADD45A, a DNA-damage inducible p53 target gene, is negatively regulated by two distinct RBPs (Figure 1). The Gorospe group showed that TIAR and the previously mentioned AUF1 interact with

AREs in the GADD45A mRNA 3'-UTR. AUF1 acts to reduce mRNA transcript stability, while TIAR inhibits translation. Additionally, these repressive effects are relieved upon treatment with the alkylating agent methyl methanesulfonate. The authors hypothesize that this decreased interaction with TIAR and AUF1, which correlates with increased GADD45A mRNA half-life and translation, may account for the rapid accumulation of GADD45A protein upon DNA damage [54].

p53-INDUCIBLE miRNAs

In addition to the impact of miRNAs and RBPs on the expression of p53 target mRNAs discussed so far, p53 itself activates transcription of both miRNAs and RBPs that in turn create another post-transcriptional regulatory layer within the network. p53 canonically functions as a transcriptional activator, leading to upregulation of a few hundred target genes, most of which are protein-coding genes [55]. However, by transactivating a few miRNAs, each of them possibly targeting hundreds of mRNAs, p53 activation may indirectly lead to the post-transcriptional repression of a much broader set of genes. Thus, p53 activity and its effects on cellular behavior must be understood to include the often-dramatic influences of these p53-inducible miRNAs (referred to hereafter as p53-miRs) on global gene expression patterns.

miR-34a is the most intensely investigated among p53-miRs. miR-34a is a tumor suppressor miRNA that first came to light as a direct p53 transcriptional target in 2007, when multiple laboratories published studies highlighting the activating effect of p53 on members of the miR-34 family [56–60]. The miR-34 family includes miR-34a, miR-34b and miR-34c. All three members share a nearly identical seed sequence and some target mRNA overlap. The primary transcripts encoding these miRNAs, however, are located on two different chromosomes. miR-34a is located at 1p36, while miR-34b/c are produced from a single primary transcript located at 11q23. Thus, two separate p53 transactivation events are required to upregulate all members of this miRNA family, which may allow for their tissue and stimulus-specific regulation. Indeed, this phenomenon has been observed in mice, where the ubiquitous miR-34a is most highly expressed in the brain, while miR-34b/c are largely limited to the lung [61, 62].

Tumor suppression by miR-34a seems to be achieved by its negative effects on a number of oncogenic pathways. miR-34a expression can contribute to cell-cycle arrest, restrain proliferation by blocking growth factor signaling, activate apoptosis and inhibit epithelial–mesenchymal transition (EMT) and metastasis. miR-34a is commonly silenced via DNA methylation in diverse cancer types, including prostate carcinoma [63], non-Hodgkins lymphoma [64] and NSCLC [61]. The miR-34a locus is also commonly deleted in many solid tumors, including stomach, colorectal, breast and endometrial cancers [65].

miR-34a aids in cell-cycle arrest by targeting cyclins and CDKs. CDK4, CDK6, cyclin D1 (CCND1) and cyclin E2 (CCNE2), each with roles in the G₁/S transition, are all verified targets of miR-34a [56, 66, 67]. Indeed, ectopic expression of miR-34a in cancer cell lines leads to decreased protein levels of these targets and increased cell-cycle arrest in the G₁ phase [56, 66].

Additional anti-proliferative effects of miR-34a are achieved by repression of growth factor receptor tyrosine kinases (RTKs) and their downstream kinase pathways (Figure 2). miR-34a represses two strongly oncogenic RTKs, MET and EGFR. Interestingly, while MET is a direct target of miR-34a [68, 69], EGFR is downregulated by the post-transcriptional regulation of one of its activating transcription factors, Yin Yang-1 [65]. Abrogation of this regulatory mechanism, which induces a hyper-activated growth factor cascade is a poor clinical marker in glioblastoma multiforme patients, where concomitant loss of miR-34a and amplification of EGFR correlates with significantly decreased survival time [65]. Acting downstream of RTK signaling, miR-34a also targets several members of the RAS/RAF/MAPK pathway as well as PIK3R2, a regulatory subunit of PI3K and perhaps the second most commonly deregulated oncogene, next to RAS [70].

Beyond effects on cell proliferation, miR-34a also seems to be involved in apoptosis, as it targets BCL2, a potent oncogene in various malignancies. BCL2 binds to and inhibits pro-apoptotic BH3-only proteins, such as PUMA, thus preventing activation of the intrinsic apoptotic pathway [28]. miR-34a has clearly been shown to target the 3'-UTR of BCL2 mRNA [62], which may have important implications in the cellular response to MDM2 inhibitors. Indeed, in cancer cell lines where MDM2 inhibitors induce cell-cycle arrest, the response can

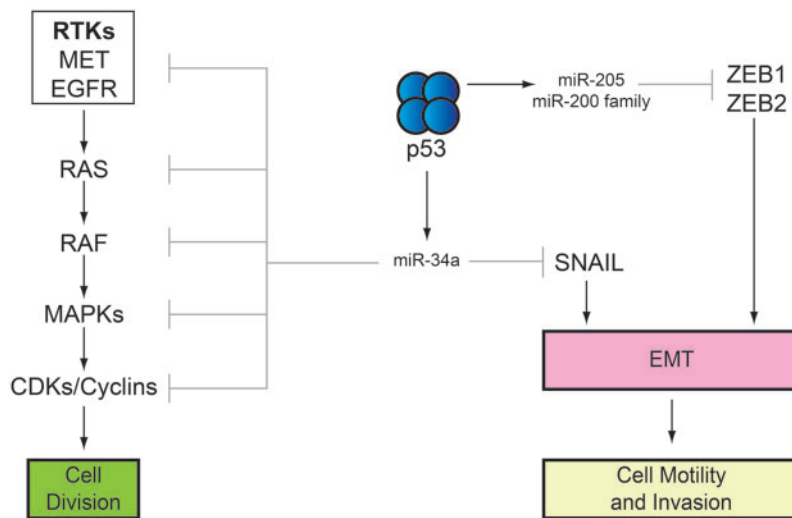

Figure 2: p53-induced miR-34a opposes oncogenic phenotypes. miR-34a limits cell division by targeting mRNAs of several members of RTK/RAS/RAF/MAPK cascades. miR-34a also targets SNAIL, while the miR-200 family and miR-205 target ZEB1/2 to prevent EMT.

be switched to apoptosis via BCL2 shRNAs or BH3 mimetics [9, 71].

The EMT is considered an initiating event in the metastatic cascade, as it leads to loss of cell adhesion, increased cell motility and invasion. EMT is orchestrated in the nucleus by key transcriptional repressors, including but not restricted to, SNAIL, ZEB1 and ZEB2 [72]. Interestingly, miR-34a targets SNAIL [73], linking p53 activation to repression of EMT and metastasis, a recurring theme among p53-miRs (Figure 2). miR-205 is another tumor suppressor miRNA directly transactivated by p53 with repressive effects on EMT. miR-205 is commonly repressed in human breast cancer, and reintroduction of miR-205 into highly aggressive triple-negative breast cancer cell lines leads to decreased cell proliferation and cell-cycle arrest [74]. It is also commonly downregulated in prostate cancer, so much so that its relative abundance is a clear marker for distinguishing between cancerous and normal prostate tissue [75]. The Zaffaroni group showed that reintroduction of miR-205 into prostate cancer cells is sufficient to suggest a reversal of EMT, as highlighted by changes in cell morphology, increased cell-to-cell adhesion, and decreased invasiveness [75]. Mechanistically, miR-205 may achieve these effects via repression of ZEB1 and ZEB2 (Figure 2) [76]. In addition, ZEB1 and ZEB2 are also targeted by members of the miR-200 family, another group of p53-miRs. p53 induces transcription and processing of the two polycistronic transcripts encoding miR-200 family members,

thereby limiting ZEB1 and ZEB2 expression and preventing EMT [77].

p53-INDUCED RBPs: RNPC1 AND QKI

In addition to miRNAs, p53 also modulates post-transcriptional events by directly transactivating at least two RBPs: RNPC1 and Quaking (QKI). RNPC1 is an RBP of increasing importance that controls several mRNAs within the p53 network. RNPC1 works in concert with HuR to promote p21 stability [78]. The Chen group has extensively documented the role of RNPC1 in regulating not only p21, but also p53 family members p63 and p73, as well as MDM2 [78–81]. RNPC1 stabilizes p73, while downregulating p63, MDM2 and p53 itself. In mouse embryonic fibroblasts (MEFs), for instance, RNPC1 is transactivated by p53 and subsequently binds sites in the p53 mRNA 5′- and 3′-UTRs to inhibit p53 translation. Zhang *et al.* showed that a loss of RNPC1 leads to p53-dependent senescence in primary MEFs [82]. In this case, dampening the p53 transcriptional response by modulating p53 expression itself appears to prevent a senescent phenotype under healthy physiological cellular conditions. In contrast, human esophageal adenocarcinoma patients resistant to radiation therapy tend to overexpress RNPC1. Human cell culture studies showed that this overexpression correlates with increased p21 and p53 levels, along with increased G₀/G₁ arrest, which may explain the observed increase in resistance to radiation therapy seen in patients [83].

p53 also induces QKI, an RBP belonging to the signaling transduction and activation of RNA family. This RBP, which is frequently deleted or methylated in glioblastoma multiforme, interacts with and stabilizes miR-20a, a p53-miR itself [84]. Thus, by upregulating both the miRNA and an RBP that stabilizes it, p53 strongly reinforces miR-20a action. miR-20a binds and inhibits the translation of TGF β Receptor 2 (TGFB β R2) [84]. Knockdown of TGFB β R2 in both human glioblastoma cell culture and mouse glioma xenograft models has been shown to reduce invasiveness [85], supporting a cooperative tumor suppressive role for QKI and miR-20a.

INTEGRATING THE ACTION OF p53 PROTEIN-CODING TARGET GENES WITH miRNAs AND RBPs

The available evidence indicates that the p53-dependent cellular responses are mediated primarily by its protein-coding target genes. For example, deletion of p21 and 14-3-3 σ impairs p53-dependent cell-cycle arrest [86, 87], and ablation of PUMA and BAX renders cells refractory to p53-induced apoptosis [29, 30, 88]. However, these results do not exclude the possibility that these key protein-coding genes act in coordination with miRNAs and RBPs activated by p53 to produce specific cellular responses. Here we discuss several examples of these collaborations.

Coordinated action of p21, 14-3-3 σ , miR34a and RNPC1 in p53-dependent cell-cycle arrest

p21 inhibits cell-cycle progression, binding preformed CDK/cyclin complexes and preventing ATP binding by the kinase subunit [20]. The primary targets of p21 are the cyclin E/CDK2 and cyclin D/CDK4-6 complexes, which promote the G₁/S transition by phosphorylating Retinoblastoma (Rb) family members, leading in turn to derepression of E2F transcription factors (Figure 3A) [89]. Interestingly, miR-34a targets cyclin E2, cyclin D1, CDK4, CDK6 and E2F3, providing a second layer of repression of the cell-cycle machinery [56, 66, 90]. Thus, p53 induces two coordinated signals, p21 and miR-34a, to promote strong G₁/S arrest. In addition, p53 also induces RNPC1 to ensure high expression of p21. A similar scenario may take place during control of the G₂/M transition. The CDC2/cyclin B complex, which drives entry into mitosis, is negatively

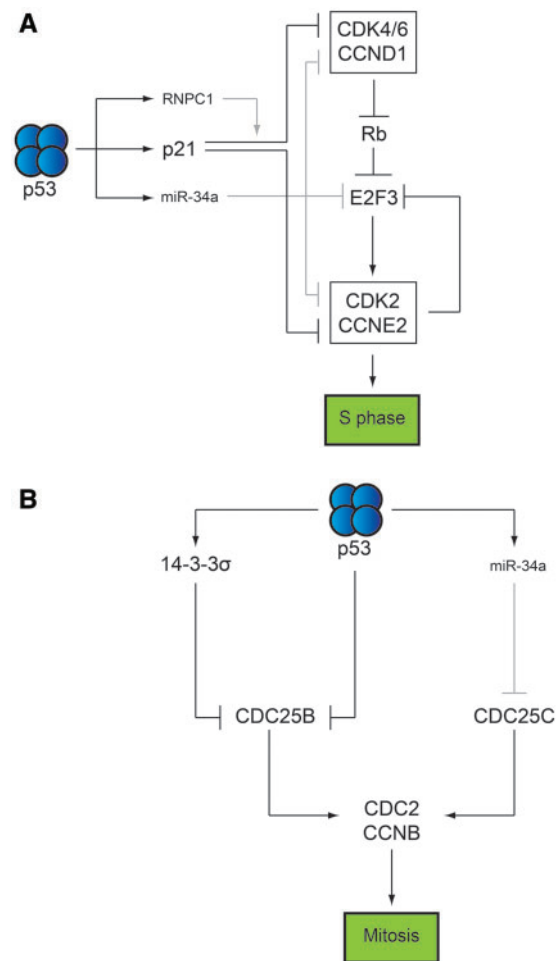

Figure 3: Coordinated action of p21, 14-3-3 σ , miR-34a and RNPC1 in p53-dependent cell-cycle arrest. **(A)** p21 and miR-34a coordinately enforce G₁/S arrest by inhibiting CDK-cyclin complexes at the protein and mRNA levels, respectively. p21 expression is coordinately upregulated by RNPC1. **(B)** 14-3-3 σ and miR-34a similarly work in concert to inhibit G₂/M transition through inhibition of CDC25 phosphatases.

regulated by tyrosine phosphorylation, and the CDC25B-C tyrosine phosphatases that remove these inhibitory phosphates are potent drivers of mitosis [91]. 14-3-3 σ is a direct target of p53 transactivation that binds to CDC25B and sequesters it in the cytoplasm, thereby preventing its action in the nucleus and driving G₂/M arrest (Figure 3B) [87, 92, 93]. Interestingly, miR-34a overexpression has been shown to cause downregulation of CDC25C expression [56, 90]. Furthermore, CDC25C transcription is seemingly repressed by p53 via direct binding to the promoter, creating a third form of repression [94]. Once again, p53 induces converging signals involving transcriptional and post-transcriptional regulation to provoke G₂/M arrest.

Coordinated repression of CD44 and RHAMM and induction of p53-miRs during p53-dependent repression of EMT and metastasis

CD44 and RHAMM (CD168) are two receptors for hyaluronan, a component of the extra cellular matrix. CD44 and RHAMM collaborate in a hyaluronan-dependent manner to promote invasion and metastasis in many cancer models [95, 96]. p53 has been demonstrated to directly repress expression of both CD44 and RHAMM via promoter binding [97, 98]. Interestingly, CD44 is also a target of miR-34a [99]. Additionally, as discussed before, three different p53-miRs (miR34a, miR-200 and miR-192) coordinately repress SNAIL, ZEB1 and ZEB2, the key transcription factors driving EMT. Finally, the p53/QKI/miR-20a/TGFBR2 axis described before further represses metastasis, at least in the context of glioblastoma (Figure 4). Thus, p53 represses cell migration, invasion and metastasis through gene repression at both the transcriptional and post-transcriptional levels.

Coordinated action of p53 protein-coding target genes and p53-miRs in induction of apoptosis

p53 induces transcription of genes involved in both the intrinsic (e.g. PUMA, NOXA and BAX) and the extrinsic (e.g. FAS, DR4 and DR5) apoptotic pathways (Figure 5). The precise contribution of each of these targets to p53-induced apoptosis varies across

cell types, and recent evidence suggests that collaboration between the intrinsic and extrinsic pathways is necessary to induce efficient apoptosis upon p53 activation [8, 100]. This collaboration occurs mainly through BID, a BH3-only protein activated by proteolytic cleavage downstream of death receptor activation [8, 101]. BID itself is a p53-target gene in some settings [102]. As mentioned before, BCL2

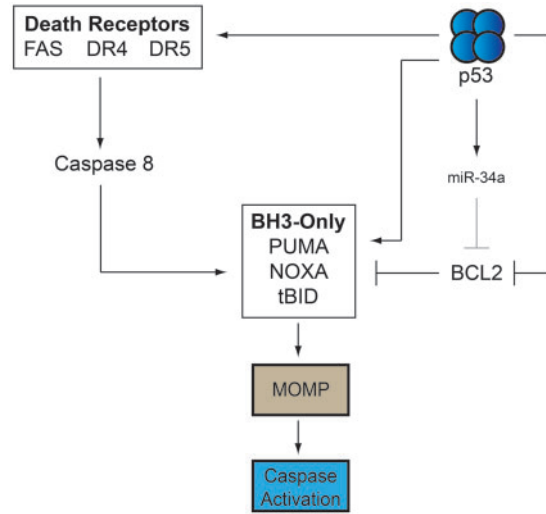

Figure 5: p53 generates multiple pro-apoptotic signals, including miR-34a-dependent repression of BCL2. By targeting mRNA of the BH3-only protein BCL2, miR-34a reinforces p53-dependent apoptotic signaling, leading to mitochondrial outer membrane permeabilization, downstream caspase activation and ultimately, apoptosis.

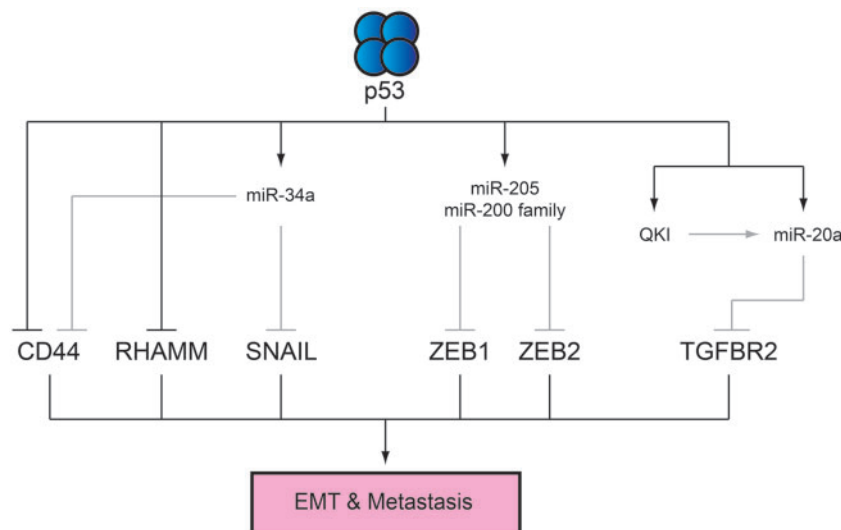

Figure 4: p53-induced miRNAs and RBP Quaking I (QKI) oppose EMT and metastasis. p53 directly transactivates multiple post-transcriptional regulators which work to prevent EMT by downregulating key effectors of this oncogenic phenotypic transformation.

antagonizes BH3-only proteins such as PUMA, NOXA and BID, inhibiting p53-dependent apoptosis. Interestingly, p53 can repress BCL2 both directly via promoter binding, and indirectly via miR-34a (Figure 5) [62, 103]. Thus, p53-induced apoptosis can be finely regulated in a context-dependent fashion at a large number of steps, one of them being miRNA-dependent.

PERSPECTIVES

A deluge of genomics data is leading to fast and comprehensive annotation of gene networks. Once the identification and functional characterization of all genes in the human genome is completed, perhaps a not too distant vision, the challenge will reside in understanding how variations in gene networks are established in a temporal and spatial fashion during organismal development, homeostasis and disease. These efforts will likely be spearheaded by studies of gene networks that have been heavily annotated and investigated, such as the p53 network. Beyond its obvious roles in cancer, the p53 network has served as a discovery platform to further our understanding of a myriad of biological processes, including transcriptional regulation, cell-cycle control and cell death, and will likely pioneer new fields of research in the post-genomic era. Up to this point much emphasis has been put on understanding the ‘transcriptional plane’ of the p53 network, but, as illustrated in this review, an increasing understanding of the ‘post-transcriptional plane’ of the network will be necessary for an elevated understanding of the roles of p53 in tumor suppression and, consequently, in the development of p53-based therapies.

Key Points

- p53 target genes are regulated at the post-transcriptional level by miRNAs and RBPs in a context-specific manner.
- miRNAs negatively regulate p53 target gene expression, while RBPs can have a positive or negative impact on expression.
- p53 itself is responsible for transactivation of several miRNAs and RBPs.
- Members of the p53 network, including miRNAs and RBPs, work coordinately with protein-coding p53 targets during tumor suppression.

Acknowledgements

The authors thank members of the Espinosa Lab for ideas and discussion.

FUNDING

Work in the Espinosa Lab is supported by National Institutes of Health [2R01CA117907-06]. J.M.E. is an HHMI Early Career Scientist.

References

1. Rivlin N, Brosh R, Oren M, *et al.* Mutations in the p53 tumor suppressor gene: important milestones at the various steps of tumorigenesis. *Genes Cancer* 2011;**2**:466–12.
2. Brady CA, Jiang D, Mello SS, *et al.* Distinct p53 transcriptional programs dictate acute DNA-damage responses and tumor suppression. *Cell* 2011;**145**:571–83.
3. Li T, Kon N, Jiang L, *et al.* Tumor suppression in the absence of p53-mediated cell-cycle arrest, apoptosis, and senescence. *Cell* 2012;**149**:1269–83.
4. Vousden KH, Prives C. Blinded by the light: the growing complexity of p53. *Cell* 2009;**137**:413–31.
5. Brown CJ, Lain S, Verma CS, *et al.* Awakening guardian angels: drugging the p53 pathway. *Nat Rev Cancer* 2009;**9**:862–73.
6. Tovar C, Rosinski J, Filipovic Z, *et al.* Small-molecule MDM2 antagonists reveal aberrant p53 signaling in cancer: implications for therapy. *Proc Natl Acad Sci USA* 2006;**103**:1888–93.
7. Paris R, Henry RE, Stephens SJ, *et al.* Multiple p53-independent gene silencing mechanisms define the cellular response to p53 activation. *Cell Cycle* 2008;**7**:2427–33.
8. Henry RE, Andrysiak Z, Paris R, *et al.* A DR4:tBID axis drives the p53 apoptotic response by promoting oligomerization of poised BAX. *EMBOJ* 2012;**31**:1266–78.
9. Sullivan KD, Padilla-Just N, Henry RE, *et al.* ATM and MET kinases are synthetic lethal with nongenotoxic activation of p53. *Nat Chem Biol* 2012;**8**(7):646–54.
10. Zhao R, Gish K, Murphy M, *et al.* Analysis of p53-regulated gene expression patterns using oligonucleotide arrays. *Genes Dev* 2000;**14**:981–93.
11. Wei CL, Wu Q, Vega VB, *et al.* A global map of p53 transcription-factor binding sites in the human genome. *Cell* 2006;**124**:207–19.
12. Donner AJ, Szostek S, Hoover JM, *et al.* CDK8 Is a stimulus-specific positive coregulator of p53 target genes. *Mol Cell* 2007;**27**:121–33.
13. Espinosa JM, Emerson BM. Transcriptional regulation by p53 through intrinsic DNA/chromatin binding and site-directed cofactor recruitment. *Mol Cell* 2001;**8**:57–69.
14. Espinosa JM, Verdun RE, Emerson BM. p53 functions through stress- and promoter-specific recruitment of transcription initiation components before and after DNA damage. *Mol Cell* 2003;**12**:1015–27.
15. Gu W, Malik S, Ito M, *et al.* A novel human SRB/MED-containing cofactor complex, SMCC, involved in transcription regulation. *Mol Cell* 1999;**3**:97–108.
16. Bartel DP. MicroRNAs: target recognition and regulatory functions. *Cell* 2009;**136**:215–33.
17. el-Deiry WS, Tokino T, Velculescu VE, *et al.* WAF1, a potential mediator of p53 tumor suppression. *Cell* 1993;**75**:817–25.

18. el-Deiry WS, Harper JW, O'Connor PM, *et al.* WAF1/CIP1 is induced in p53-mediated G1 arrest and apoptosis. *Cancer Res* 1994;**54**:1169–74.
19. Harper JW, Adami GR, Wei N, *et al.* The p21 Cdk-interacting protein Cip1 is a potent inhibitor of G1 cyclin-dependent kinases. *Cell* 1993;**75**:805–16.
20. Harper JW, Elledge SJ, Keyomarsi K, *et al.* Inhibition of cyclin-dependent kinases by p21. *Mol Biol Cell* 1995;**6**:387–400.
21. Conkrite K, Sundby M, Mukai S, *et al.* miR-17~92 co-operates with RB pathway mutations to promote retinoblastoma. *Genes Dev* 2011;**25**:1734–45.
22. Fontana L, Fiori ME, Albini S, *et al.* Antagomir-17-5p abolishes the growth of therapy-resistant neuroblastoma through p21 and BIM. *PLoS One* 2008;**3**:e2236.
23. Ivanovska I, Ball AS, Diaz RL, *et al.* MicroRNAs in the miR-106b family regulate p21/CDKN1A and promote cell cycle progression. *Mol Cell Biol* 2008;**28**:2167–74.
24. Huang G, Nishimoto K, Zhou Z, *et al.* miR-20a encoded by the miR-17-92 cluster increases the metastatic potential of osteosarcoma cells by regulating Fas expression. *Cancer Res* 2012;**72**:908–16.
25. Pan J, Hu H, Zhou Z, *et al.* Tumor-suppressive mir-663 gene induces mitotic catastrophe growth arrest in human gastric cancer cells. *Oncol Rep* 2010;**24**:105–12.
26. Yi C, Wang Q, Wang L, *et al.* MiR-663, a microRNA targeting p21(WAF1/CIP1), promotes the proliferation and tumorigenesis of nasopharyngeal carcinoma. *Oncogene* 2012;**31**(41):4421–33.
27. Gottwein E, Cullen BR. A human herpesvirus microRNA inhibits p21 expression and attenuates p21-mediated cell cycle arrest. *J Virol* 2010;**84**:5229–37.
28. Jin Z, El-Deiry WS. Overview of cell death signaling pathways. *Cancer Biol Ther* 2005;**4**:139–63.
29. Nakano K, Vousden KH. PUMA, a novel proapoptotic gene, is induced by p53. *Mol Cell* 2001;**7**:683–94.
30. Yu J, Zhang L, Hwang PM, *et al.* PUMA induces the rapid apoptosis of colorectal cancer cells. *Mol Cell* 2001;**7**:673–82.
31. Zhang C, Zhang J, Zhang A, *et al.* PUMA is a novel target of miR-221/222 in human epithelial cancers. *Int J Oncol* 2010;**37**:1621–6.
32. Zhang CZ, Zhang JX, Zhang AL, *et al.* MiR-221 and miR-222 target PUMA to induce cell survival in glioblastoma. *Mol Cancer* 2010;**9**:229.
33. Garofalo M, Di Leva G, Romano G, *et al.* miR-221&222 regulate TRAIL resistance and enhance tumorigenicity through PTEN and TIMP3 downregulation. *Cancer Cell* 2009;**16**:498–509.
34. Lerner M, Haneklaus M, Harada M, *et al.* MiR-200c regulates Noxa expression and sensitivity to proteasomal inhibitors. *PLoS One* 2012;**7**:e36490.
35. Muller M, Wilder S, Bannasch D, *et al.* p53 activates the CD95 (APO-1/Fas) gene in response to DNA damage by anticancer drugs. *J Exp Med* 1998;**188**:2033–45.
36. Wu GS, Burns TF, McDonald ER, III, *et al.* KILLER/DR5 is a DNA damage-inducible p53-regulated death receptor gene. *Nat Genet* 1997;**17**:141–3.
37. Liu X, Yue P, Khuri FR, *et al.* p53 upregulates death receptor 4 expression through an intronic p53 binding site. *Cancer Res* 2004;**64**:5078–83.
38. Wang S, Tang Y, Cui H, *et al.* Let-7/miR-98 regulate Fas and Fas-mediated apoptosis. *Genes Immun* 2011;**12**:149–54.
39. Momand J, Zambetti GP, Olson DC, *et al.* The mdm-2 oncogene product forms a complex with the p53 protein and inhibits p53-mediated transactivation. *Cell* 1992;**69**:1237–45.
40. Oliner JD, Pietenpol JA, Thiagalingam S, *et al.* Oncoprotein MDM2 conceals the activation domain of tumour suppressor p53. *Nature* 1993;**362**:857–60.
41. Kubbutat MH, Jones SN, Vousden KH. Regulation of p53 stability by Mdm2. *Nature* 1997;**387**:299–303.
42. Tao W, Levine AJ. Nucleocytoplasmic shuttling of oncoprotein Hdm2 is required for Hdm2-mediated degradation of p53. *Proc Natl Acad Sci USA* 1999;**96**:3077–80.
43. Xiao J, Lin H, Luo X, *et al.* miR-605 joins p53 network to form a p53:miR-605:Mdm2 positive feedback loop in response to stress. *EMBO J* 2011;**30**:524–32.
44. Zhang J, Sun Q, Zhang Z, *et al.* Loss of microRNA-143/145 disturbs cellular growth and apoptosis of human epithelial cancers by impairing the MDM2-p53 feedback loop. *Oncogene* 2012; doi:10.1038/onc.2012.28 (Advance Access publication 13 February 2012).
45. Pichiorni F, Suh SS, Rocci A, *et al.* Downregulation of p53-inducible microRNAs 192, 194, and 215 impairs the p53/MDM2 autoregulatory loop in multiple myeloma development. *Cancer Cell* 2010;**18**:367–81.
46. Lujambio A, Lowe SW. The microcosmos of cancer. *Nature* 2012;**482**:347–55.
47. Scoumanne A, Cho SJ, Zhang J, *et al.* The cyclin-dependent kinase inhibitor p21 is regulated by RNA-binding protein PCBP4 via mRNA stability. *Nucleic Acids Res* 2011;**39**:213–24.
48. Battelli C, Nikopoulos CN, Mitchell JG, *et al.* The RNA-binding protein Musashi-1 regulates neural development through the translational repression of p21WAF-1. *Mol Cell Neurosci* 2006;**31**:85–96.
49. Nikpour P, Baygi ME, Steinhoff C, *et al.* The RNA binding protein Musashi1 regulates apoptosis, gene expression and stress granule formation in urothelial carcinoma cells. *J Cell Mol Med* 2011;**15**:1210–24.
50. Sureban SM, May R, George RJ, *et al.* Knockdown of RNA binding protein musashi-1 leads to tumor regression *in vivo*. *Gastroenterology* 2008;**134**:1448–58.
51. Wang W, Furneaux H, Cheng H, *et al.* HuR regulates p21 mRNA stabilization by UV light. *Mol Cell Biol* 2000;**20**:760–9.
52. Mazan-Mamczarz K, Galban S, Lopez de Silanes I, *et al.* RNA-binding protein HuR enhances p53 translation in response to ultraviolet light irradiation. *Proc Natl Acad Sci USA* 2003;**100**:8354–9.
53. Lal A, Mazan-Mamczarz K, Kawai T, *et al.* Concurrent versus individual binding of HuR and AUF1 to common labile target mRNAs. *EMBO J* 2004;**23**:3092–102.
54. Lal A, Abdelmohsen K, Pullmann R, *et al.* Posttranscriptional derepression of GADD45alpha by genotoxic stress. *Mol Cell* 2006;**22**:117–28.
55. Riley T, Sontag E, Chen P, *et al.* Transcriptional control of human p53-regulated genes. *Nat Rev Mol Cell Biol* 2008;**9**:402–12.

56. He L, He X, Lim LP, *et al.* A microRNA component of the p53 tumour suppressor network. *Nature* 2007;**447**:1130–4.
57. Hermeking H. p53 enters the microRNA world. *Cancer Cell* 2007;**12**:414–8.
58. Chang TC, Wentzel EA, Kent OA, *et al.* Transactivation of miR-34a by p53 broadly influences gene expression and promotes apoptosis. *Mol Cell* 2007;**26**(5):745–52.
59. Raver-Shapira N, Marciano E, Meiri E, *et al.* Transcriptional activation of miR-34a contributes to p53-mediated apoptosis. *Mol Cell* 2007;**26**:731–43.
60. Tarasov V, Jung P, Verdoodt B, *et al.* Differential regulation of microRNAs by p53 revealed by massively parallel sequencing: miR-34a is a p53 target that induces apoptosis and G(1)-arrest. *Cell Cycle* 2007;**6**(13):1586–93.
61. Lodygin D, Tarasov V, Epanchintsev A, *et al.* Inactivation of miR-34a by aberrant CpG methylation in multiple types of cancer. *Cell Cycle* 2008;**7**:2591–600.
62. Bommer GT, Gerin I, Feng Y, *et al.* p53-mediated activation of miRNA34 candidate tumor-suppressor genes. *Curr Biol* 2007;**17**:1298–307.
63. Tanaka N, Toyooka S, Soh J, *et al.* Frequent methylation and oncogenic role of microRNA-34b/c in small-cell lung cancer. *Lung Cancer* 2012;**76**:32–8.
64. Chim CS, Wong KY, Qi Y, *et al.* Epigenetic inactivation of the miR-34a in hematological malignancies. *Carcinogenesis* 2010;**31**:745–50.
65. Yin D, Ogawa S, Kawamata N, *et al.* miR-34a functions as a tumor suppressor modulating EGFR in glioblastoma multiforme. *Oncogene* 2012; doi:10.1038/onc.2012.132 (Advance Access publication 14 May 2012).
66. Sun F, Fu H, Liu Q, *et al.* Downregulation of CCND1 and CDK6 by miR-34a induces cell cycle arrest. *FEBS Lett* 2008;**582**:1564–8.
67. Toyota M, Suzuki H, Sasaki Y, *et al.* Epigenetic silencing of microRNA-34b/c and B-cell translocation gene 4 is associated with CpG island methylation in colorectal cancer. *Cancer Res* 2008;**68**:4123–32.
68. Yan D, Zhou X, Chen X, *et al.* MicroRNA-34a inhibits uveal melanoma cell proliferation and migration through downregulation of c-Met. *Invest Ophthalmol Vis Sci* 2009;**50**:1559–65.
69. Migliore C, Petrelli A, Ghiso E, *et al.* MicroRNAs impair MET-mediated invasive growth. *Cancer Res* 2008;**68**:10128–36.
70. Lal A, Thomas MP, Altschuler G, *et al.* Capture of microRNA-bound mRNAs identifies the tumor suppressor miR-34a as a regulator of growth factor signaling. *PLoS Genet* 2011;**7**:e1002363.
71. Wade M, Rodewald LW, Espinosa JM, *et al.* BH3 activation blocks Hdmx suppression of apoptosis and cooperates with Nutlin to induce cell death. *Cell Cycle* 2008;**7**:1973–82.
72. Peinado H, Olmeda D, Cano A. Snail, Zeb and bHLH factors in tumour progression: an alliance against the epithelial phenotype? *Nat Rev Cancer* 2007;**7**:415–28.
73. Siemens H, Jackstadt R, Hunten S, *et al.* miR-34 and SNAIL form a double-negative feedback loop to regulate epithelial-mesenchymal transitions. *Cell Cycle* 2011;**10**:4256–71.
74. Piovan C, Palmieri D, Di Leva G, *et al.* Oncosuppressive role of p53-induced miR-205 in triple negative breast cancer. *Mol Oncol* 2012;**6**(4):458–72.
75. Gandellini P, Profumo V, Casamichela A, *et al.* miR-205 regulates basement membrane deposition in human prostate: implications for cancer development. *Cell Death Differ* 2012;**19**(11):1750–60.
76. Hill L, Browne G, Tulchinsky E. ZEB/miR-200 feedback loop: at the crossroads of signal transduction in cancer. *Int J Cancer* 2012; doi:10.1002/ijc.27708 (Advance Access publication 2 July 2012).
77. Kim T, Veronese A, Pichiorri F, *et al.* p53 regulates epithelial-mesenchymal transition through microRNAs targeting ZEB1 and ZEB2. *J Exp Med* 2011;**208**:875–83.
78. Cho SJ, Zhang J, Chen X. RNPC1 modulates the RNA-binding activity of, and cooperates with, HuR to regulate p21 mRNA stability. *Nucleic Acids Res* 2010;**38**:2256–67.
79. Xu E, Zhang J, Chen X. MDM2 expression is repressed by the RNA-binding protein RNPC1 via mRNA stability. *Oncogene* 2012; doi:10.1038/onc.2012.238 (Advance Access publication 18 June 2012).
80. Yan W, Zhang J, Zhang Y, *et al.* p73 expression is regulated by RNPC1, a target of the p53 family, via mRNA stability. *Mol Cell Biol* 2012;**32**:2336–48.
81. Zhang J, Jun Cho S, Chen X. RNPC1, an RNA-binding protein and a target of the p53 family, regulates p63 expression through mRNA stability. *Proc Natl Acad Sci USA* 2010;**107**:9614–9.
82. Zhang J, Cho SJ, Shu L, *et al.* Translational repression of p53 by RNPC1, a p53 target overexpressed in lymphomas. *Genes Dev* 2011;**25**:1528–43.
83. Hotte GJ, Linam-Lennon N, Reynolds JV, *et al.* Radiation sensitivity of esophageal adenocarcinoma: the contribution of the RNA-binding protein RNPC1 and p21-mediated cell cycle arrest to radioresistance. *Radiation Res* 2012;**177**:272–9.
84. Chen AJ, Paik JH, Zhang H, *et al.* STAR RNA-binding protein Quaking suppresses cancer via stabilization of specific miRNA. *Genes Dev* 2012;**26**:1459–72.
85. Wesolowska A, Kwiatkowska A, Slomnicki L, *et al.* Microglia-derived TGF-beta as an important regulator of glioblastoma invasion—an inhibition of TGF-beta-dependent effects by shRNA against human TGF-beta type II receptor. *Oncogene* 2008;**27**:918–30.
86. Waldman T, Kinzler KW, Vogelstein B. p21 is necessary for the p53-mediated G1 arrest in human cancer cells. *Cancer Res* 1995;**55**:5187–90.
87. Hermeking H, Lengauer C, Polyak K, *et al.* 14-3-3 sigma is a p53-regulated inhibitor of G2/M progression. *Mol Cell* 1997;**1**:3–11.
88. Zhang L, Yu J, Park BH, *et al.* Role of BAX in the apoptotic response to anticancer agents. *Science* 2000;**290**:989–92.
89. Sun A, Bagella L, Tutton S, *et al.* From G0 to S phase: a view of the roles played by the retinoblastoma (Rb) family members in the Rb-E2F pathway. *J Cell Biochem* 2007;**102**:1400–4.
90. Tazawa H, Tsuchiya N, Izumiya M, *et al.* Tumor-suppressive miR-34a induces senescence-like growth arrest through modulation of the E2F pathway in human colon cancer cells. *Proc Natl Acad Sci USA* 2007;**104**:15472–7.
91. De Wulf P, Montani F, Visintin R. Protein phosphatases take the mitotic stage. *Curr Opin Cell Biol* 2009;**21**:806–15.
92. Peng CY, Graves PR, Thoma RS, *et al.* Worms, mitotic and G2 checkpoint control: regulation of 14-3-3 protein

- binding by phosphorylation of Cdc25C on serine-216. *Science* 1997;**277**:1501–5.
93. Dalal SN, Schweitzer CM, Gan J, *et al.* Cytoplasmic localization of human cdc25C during interphase requires an intact 14-3-3 binding site. *Mol Cell Biol* 1999;**19**: 4465–79.
 94. St Clair S, Giono L, Varmeh-Ziaie S, *et al.* DNA damage-induced downregulation of Cdc25C is mediated by p53 via two independent mechanisms: one involves direct binding to the cdc25C promoter. *Mol Cell* 2004;**16**:725–36.
 95. Maxwell CA, McCarthy J, Turley E. Cell-surface and mitotic-spindle RHAMM: moonlighting or dual oncogenic functions? *J Cell Sci* 2008;**121**:925–32.
 96. Ponta H, Sherman L, Herrlich PA. CD44: from adhesion molecules to signalling regulators. *Nat Rev Mol Cell Biol* 2003;**4**:33–45.
 97. Godar S, Ince TA, Bell GW, *et al.* Growth-inhibitory and tumor-suppressive functions of p53 depend on its repression of CD44 expression. *Cell* 2008;**134**:62–73.
 98. Sohr S, Engeland K. RHAMM is differentially expressed in the cell cycle and downregulated by the tumor suppressor p53. *Cell Cycle* 2008;**7**:3448–60.
 99. Liu C, Kelnar K, Liu B, *et al.* The microRNA miR-34a inhibits prostate cancer stem cells and metastasis by directly repressing CD44. *Nat Med* 2011;**17**:211–5.
 100. Kuribayashi K, Finnberg N, Jeffers JR, *et al.* The relative contribution of pro-apoptotic p53-target genes in the triggering of apoptosis following DNA damage in vitro and in vivo. *Cell Cycle* 2011;**10**:2380–9.
 101. Li H, Zhu H, Xu CJ, *et al.* Cleavage of BID by caspase 8 mediates the mitochondrial damage in the Fas pathway of apoptosis. *Cell* 1998;**94**:491–501.
 102. Sax JK, Fei P, Murphy ME, *et al.* BID regulation by p53 contributes to chemosensitivity. *Nat Cell Biol* 2002;**4**: 842–9.
 103. Wu Y, Mehew JW, Heckman CA, *et al.* Negative regulation of bcl-2 expression by p53 in hematopoietic cells. *Oncogene* 2001;**20**:240–51.