

The Impact of SIPOC on Process Reengineering and Sustainability of Enterprise Procurement Management in E-Commerce Environments Using Deep Learning

Hui Zhang, Pai Chai University, Daejeon, South Korea

Lijun Fan, School of Business Administration, Hunan University of Technology and Business, Changsha, China

Min Chen, School of Business, Wenzhou University, Wenzhou, China*

Chen Qiu, School of Economics and Management, Wuhan University, Wuhan, China

ABSTRACT

In order to better promote the healthy and long-term development of enterprise procurement management process, under the background of e-commerce environment, suppliers-inputs-process-outputs-customers (SIPOC) model, deep learning, and related theories of enterprise procurement management are expounded and proposed. Then, D electric power enterprise is studied as a sample. After understanding the current situation of procurement management of the enterprise, there are a series of problems in the enterprise, such as complex process, and no correlation between procurement management process and overall strategic planning. Finally, through the analysis of the early warning indicators of the enterprise by the deep learning algorithm, the procurement management process has caused certain risks to the financial management level of the enterprise, and the procurement management process of the enterprise needs to be adjusted. The material record and consumption scheme of the enterprise is optimized by using the SIPOC organizational system model.

KEYWORDS

Deep Learning, E-Commerce, Enterprise Procurement Management Process, SIPOC Model

INTRODUCTION

Procurement is an indispensable core link and important part of enterprise management in both the production and operation of traditional and modern enterprises. The efficiency of enterprise procurement management directly affects enterprise production and operation efficiency. Since the 21st century, the advent of the era of globalization and informationization has intensified enterprise competition, increasing the intensity of market development. Additionally, the diversified development

DOI: 10.4018/JOEUC.306270

*Corresponding Author

This article published as an Open Access article distributed under the terms of the Creative Commons Attribution License (<http://creativecommons.org/licenses/by/4.0/>) which permits unrestricted use, distribution, and production in any medium, provided the author of the original work and original publication source are properly credited.

of consumer demands and advancement of technology have shortened the production cycle of enterprise products. Regarding competition, enterprises must reduce delivery time and improve the quality of products and services to meet the needs of consumers and improve market competitiveness. Enterprises must be efficient in their response to consumer changes and market demands through targeted, differentiated services. In addition, deep learning has gained attention with the rise of artificial intelligence (AI). Following its formal proposal in 2006, deep learning has now become a motivating factor in the progression of AI (He et al., 2020; Zhong et al., 2021).

Pochynok et al. (2021) divided procurement into the following stages from the contribution of procurement to corporate performance: (1) new generation; (2) awakening; (3) development; (4) maturity; and (5) integration. Wang (2017) reformulated the concept of procurement management, noting that it must be completed on the premise of satisfying procurement and procurement planning. Relevant science and technology were used to achieve the normal operation of the enterprise (Ancarani & Capaldo, 2005; Liu et al., 2020a; Yang et al., 2021,). Further essential requirements include standardizing the procurement process, specifying a complete flow chart, and performing real-time tracking (Wu et al., 2017). Lenders (2017) viewed procurement as the process of purchasing materials and services. Procurement management should not only bring benefits to enterprise development but also minimize procurement costs (Sitar-Tăut & Mican, 2020; Wu et al., 2021). The prediction model has the advantages of both the searchability of the genetic algorithm and stability of the neural network (Zheng et al., 2021a). However, there is related research on the improvement of procurement management efficiency. Fundamentally, research shows the improvement of procurement management efficiency of enterprises from the perspective of external factors. There is relatively little analysis of the improvement of procurement management efficiency of enterprises themselves.

From the perspective of e-commerce, the suppliers-inputs-process-outputs-customers (SIPOC) model, deep learning, and related theories of enterprise procurement management are expounded. Then, D Electric Power Enterprise is sampled to explore the current situation of enterprise procurement management. The deep learning algorithm and SIPOC model are used to conduct an in-depth analysis and research on the procurement management process of D Electric. The traditional model has been optimized to provide a more favorable approach for future enterprise procurement management.

The innovation lies in enriching the case study of enterprise procurement management. Scholars have done extensive research on enterprise procurement management. There are many corresponding pieces of literature at the theoretical and practical levels. However, research on the procurement management of scientific research enterprises, especially the procurement management of electric power scientific research enterprises, is rarely involved. This study has enriched the research cases of enterprise procurement management, improving the depth and breadth of the research field of procurement management.

SIPOC MODEL AND DEEP LEARNING

Relevant Theoretical Basis

SIPOC is an organizational system model used for process management and improving technologies. It is the preferred method as the core process (Meng et al., 2021). The SIPOC model is proposed by the famous quality master, Dai Ming (Liu et al., 2020b; Liu et al., 2022), who noted that organizations are composed of suppliers, inputs, processes, outputs, and customers (Lei, 2020). The specific model process is shown in Figures 1 and 2.

The guiding significance of the SIPOC model is to change traditional ideas. People have always regarded customers and suppliers as a separate subject. The SIPOC model studies customers, suppliers, and enterprises as a whole (Deng & Zhao, 2022; Zheng et al., 2021b; Zheng et al., 2022; Zhu, 2021).

In 2006, deep learning, a new research direction in the field of machine learning, began to attract academic attention. In 2012, Stanford University used 16,000 central process unit (CPU)

Figure 1. Flowchart of the SIPOC model

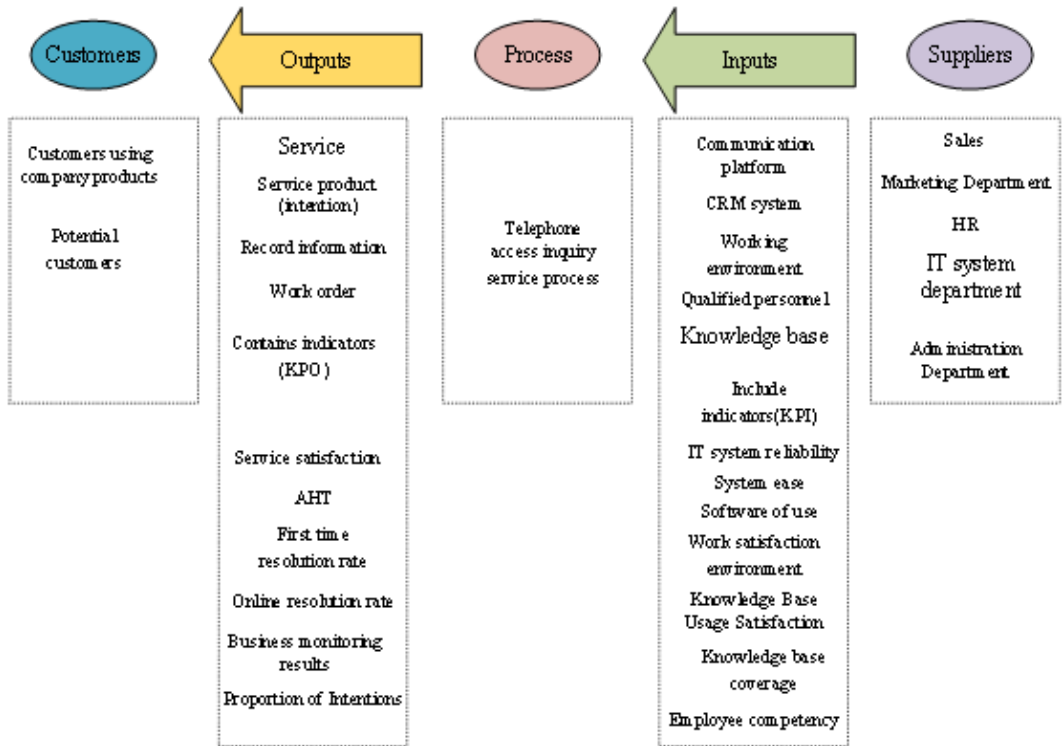
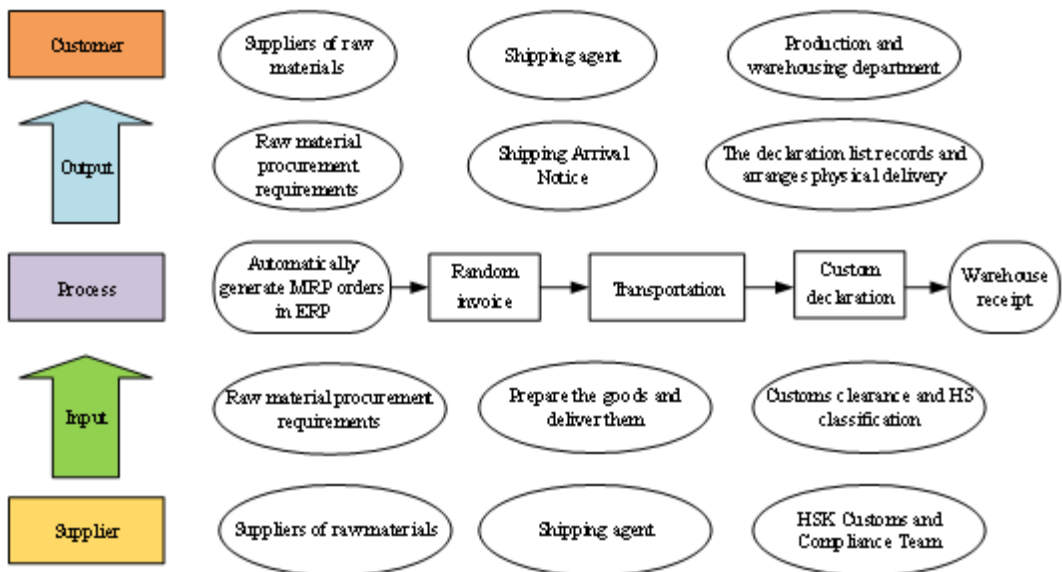

Figure 2. Process details in the SIPOC model



parallel computing platforms to build a deep neural networks (DNN) training model. DNN has made breakthroughs in speech, image recognition, and other applications. In 2016, AlphaGo, an artificial software that uses deep learning, defeated Lee Sedol, the world’s Go master. Since then, the world’s well-known high-tech companies have invested resources in deep learning. A large number of technical research and development (R&D) personnel are now entering the field of deep learning as deep learning research institutes have been established (Xia et al., 2021).

Machine learning technology studies how computers simulate or implement learning behaviors of animals to learn new knowledge or skills, rewrite existing data structures, and improve program performance. Obviously, deep learning is strongly correlated with neural networks in machine learning. Deep learning can also be called an “improved” neural network algorithm (Cerqueus et al., 2020; Westland, 2020). The deep learning theoretical model is shown in Figure 3.

The convolutional neural network (CNN) model, an example of a deep learning model, consists of four main parts: (1) input layer; (2) convolution layer; (3) pooling layer; and (4) fully connected layer (see Figure 4).

Long short-term memory (LSTM) is an improved version of recurrent neural networks (RNN), as shown in Figure 5.

In Figure 5, the output vector of the previous timestamp and input of the current timestamp pass through the activation function \tanh to obtain a new output vector. σ is the sigmoid activation function. Based on this chain, LSTM makes improvements inside the module. The gate is composed of three sigmoid neural network layers; a point-by-point multiplication operation strengthens the control of information. The \tanh activation function mainly processes the data for the state and output functions. The input gate controls the input of the output information of the upper layer unit to the unit information of this layer and retains the past information of the sequence. The specific expressions of each threshold layer are shown in equations (1) to (5):

$$T_t = \partial(A_t[b_{t-1}, x_t] + C_f) \tag{1}$$

Figure 3. Deep learning model

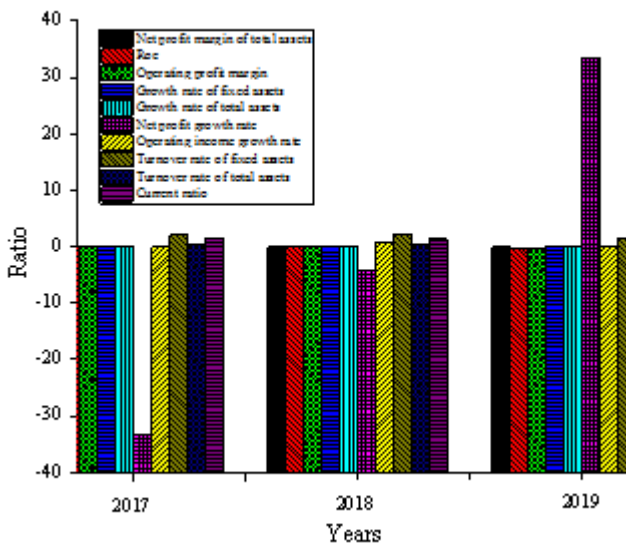

Figure 4. CNN model

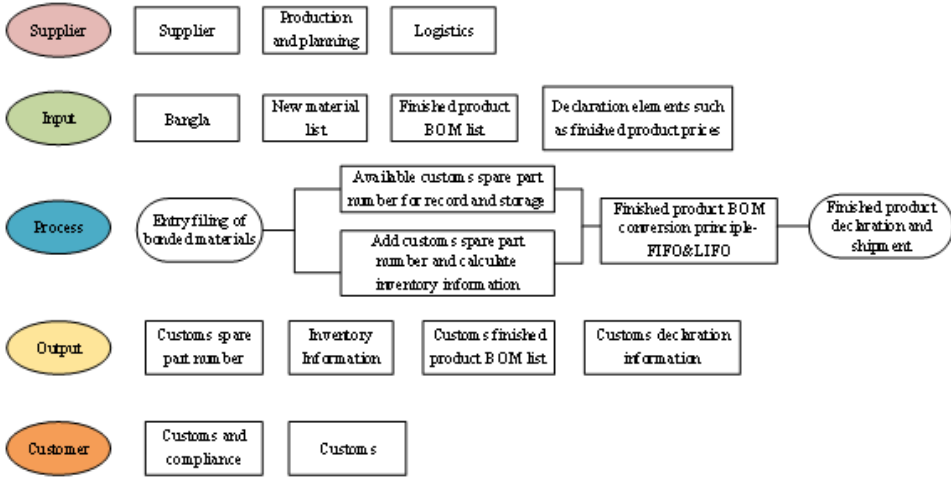
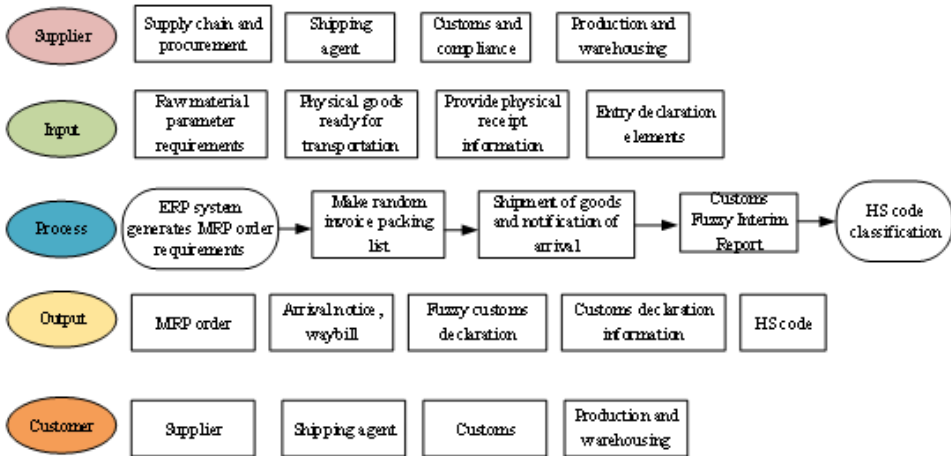

Figure 5. LSTM network model



$$I_t = \sigma(A_I \cdot [b_{t-1}, x_t] + C_I) \quad (2)$$

$$D_t = \tanh(A_D \cdot [b_{t-1}, x_t] + C_D) \quad (3)$$

$$D_t = T_t \times D_{t-1} + I_t \times D_t \quad (4)$$

$$E_t = \sigma(A_E [b_{t-1}, x_t] + C_E) \quad (5)$$

In equations (1) to (5):

- T_f represents forgetting gate
- ∂ represents hidden layer neurons
- A_f represents model output
- b_{t-1} represents hidden layer information at $t - 1$
- x_t represents input at t
- C_f and C_i represent activation functions of forgetting gate and input gate
- I_f represents input gate
- C_i represents different activation functions
- D_f represents the candidate memory cell information
- b represents the function coefficient
- A_D represents the bias of convolution kernel
- C_D represents the maximum pool
- T_f represents the average pooling
- D_{t-1} represents the hidden layer of candidate memory information at this time
- E_f represents the output gate
- A_E represents the probability of function
- C_E represents the word vector dimension

The judgment basis of the deep learning algorithm is to correct the weights and deviations of the neuron layer by observing the decline of the error function of the entire neural network (Chengjun et al., 2019). The calculation method is shown in equation (6):

$$Q_{a+1} = Q_a - c_a d_a \quad (6)$$

In equation (6), Q_a is the weight and deviation value of the network, Q_{a+1} is the weight and deviation value after iterative calculation, c_a is the speed of neural network learning, and d_a is the gradient of error function.

Purchasing management refers to the management activities of a series of procurement processes to ensure the normal operation of production. The required materials must be supplied on time. The purchasing management process includes:

1. Enterprise issued the demand for procurement materials
2. Description of procurement requirements
3. Confirmation of procurement requirements
4. Selection of suppliers
5. Identification of suppliers and signing of contracts
6. Sending goods to the enterprise
7. Receipt of goods
8. Funding settlement

Companies must recruit buyers because procurement management is an important part of strategic management. Procurement management requires employees to accurately provide material production support to the company at the most reasonable cost, at a given time, and at a given place. Purchasing management includes four aspects: (1) internal management related to procurement needs; (2) enterprise external market and related supplier management; (3) business management of procurement; and (4) basic work on procurement management.

Enterprises will buy raw materials in bulk; however, the quality of the selected materials should not be too poor and should be within a reasonable cost range. This is the economic batch order (Liu et al., 2021). The calculation process as shown in equation (7):

$$A^* = \sqrt{\frac{2AB}{EF}} = \sqrt{\frac{2AB}{D}} \quad (7)$$

In equation (1), A^* is the economic order quantity. A is the single order cost. B is the total annual demand. E is the unit price of goods (unit / piece). F is the percentage of annual storage cost of each inventory in its value. $D = EF$ is the inventory cost of unit product or the annual average storage cost of each inventory (unit / piece / year).

Research Methods

The literature method, due to its writing needs, employs CNKI, Google Scholar, Wanfang Data, and other channels for data query. Many articles exist regarding online information. In addition, many journals and books related to this study, including *E-Commerce Management Perspective*, *The Road of E-Commerce for SMEs*, and *Supplier Management Relationship* have been read in the school library. The collection and summary of this series of data provide a favorable theoretical basis for research ideas and methods.

The expert interview method involves visiting experts in procurement management of e-commerce enterprises. Their views revolve around the status quo of recent corporate procurement management in China. Some of their suggestions and opinions have been applied to increase the scientific and rationality of the article.

The case study method uses the collection of data to find representative enterprises in the market as the case of analysis. The corresponding research framework is combined with other problems in the current social reality to make the article more scientific.

The comparative analysis method compares two or more research objects to explore their similarities and differences. The good method is studied and used for reference. It aims to optimize and upgrade the enterprise procurement process in the e-commerce environment.

Overview of D Electric

A Chinese electric power enterprise, D Electric, was studied to make the research more targeted. D Electric is committed to many types of power project research. Due to its location in Shanghai, China, the company's daily material supply often needs to be imported from abroad. Customers of the enterprise are relatively extensive. They mainly work in cooperation with various provinces. D Electric helps provinces with technical development, technical advice, power maintenance, and other technical requirements of the higher work. They also conduct power R&D. D Electric has contributed to the future iteration of China's power industry, as well as the long-term and stable development of the power industry. D Electric purchases business materials related to scientific research projects and auxiliary business materials required by other enterprises. The types of enterprise procurements include power accessories, test equipment and materials, computer software, models in the process of scientific and technological research, servers, workstations, instruments and materials for the experimental process, office supplies, microwave ovens, refrigerators, and other fixed assets.

There are a total of 15 management departments and 13 business departments in D Electric. Branches are in Chengdu, Wuhan, and Beijing, respectively. The daily material procurement is completed by the ministry of materials. The company's organizational structure is shown in Figure 6.

Figure 6. Organization chart of D Electric

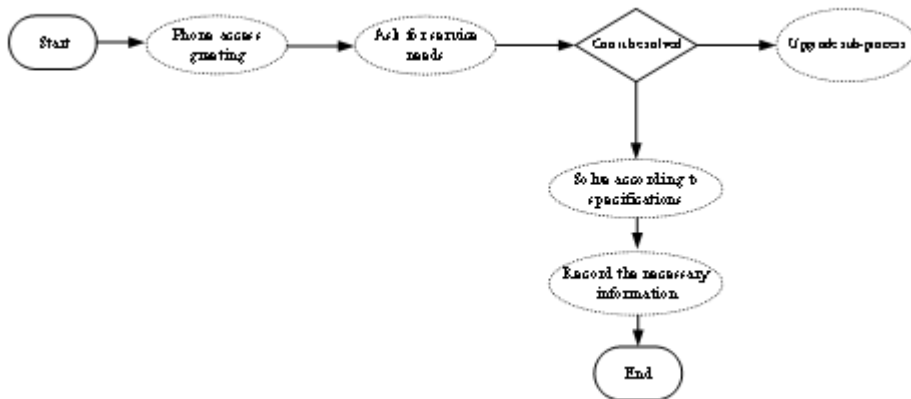

RESULTS AND ANALYSIS

Status of Procurement Management in Electric Power Enterprises

D Electric powers scientific research enterprise procurement and investment funds from various scientific and technological project contracts. These include technical services, technical consulting contracts, company headquarters’ vertical project contracts, software product sales contracts, testing contracts, achievement transformation contracts, and government project contracts. The purchased items are used for scientific research business activities, auxiliary operations, and management activities of the enterprise. Procurement types include accessories, materials for scientific research and experiments, mature software packages like developing software and modeling software, fixed assets (i.e., servers, workstations, instruments, and meters), key low-value consumables like office furniture and refrigerators, and technology development. It also includes outsourced services, such as technical services and testing. The procurement of electric power scientific research enterprises has many types and falls within a wide range. While it is difficult, it is large in quantity and amount. From 2018 to 2020, the contract value of science and technology projects of D Power scientific research enterprises continued to increase. The total procurement volume also increased, as shown in Table 1.

Table 1 shows that the number of procurement projects has gradually increased from 1,893 items (2018) to 2,074 items (2020). The total procurement budget increased from 1302.58 million yuan to 1381.38 million yuan. The total turnover has increased from 1258.72 million yuan to 1333.42 million yuan.

Table 1. Statistics of D Electric's procurement, 2018-2020

Years	Purchase situation			
	Number of procurement items (items)	Total procurement budget (10,000 yuan)	Total transaction amount (10,000 yuan)	Savings rate
2018	1,893	1302.58	1258.72	3.38%
2019	1,947	1355.31	1298.35	4.22%
2020	2,074	1381.38	1333.42	3.48%

The D enterprise adopts the project of bidding procurement mode. This will result in a serious bidding failure, which complicates the continuation of scientific and technological research projects of enterprises. The flow rate of procurement projects from 2016 to 2018 is shown in Figure 7.

Figure 7 shows that the bid-flow rate of tender projects from 2016 to 2018 is about 20%. The bid-flow rate reached a peak of about 23% in 2017. The flow rate of competitive negotiation projects is about 5%; the bid-flow rate reached its highest value, 6%, in 2017. The statistical data of D Electric and purchasing project flow mark occur in the bidding and evaluation stage. In the evaluation stage, the flow of bid is due to incomplete documents. Furthermore, the representative is not signed and the bidding site is late. The flow mark in the bidding stage is caused by the dissatisfaction of D Electric with four suppliers.

D Electric procurement of materials from its related attributes can be divided into material procurement and service procurement. The specific transaction amount from 2016 to 2018 is shown in Figure 8.

Figure 8 shows that the overall transaction amount is rising, indicating that the business volume of D Electric is increasing. From the perspective of business attributes of D Electric, a large number of scientific and technological research tasks should be undertaken. Regardless of the amount of procurement materials, it focuses on service due to the high turnover of service procurement.

Some materials needed by D Electric must be imported from abroad. Therefore, D Electric has a number of required materials (called “spare parts number” of the enterprise). To facilitate the supervision of materials, the customs department has its own number (called “customs spare parts”). However, after each import of batch materials, D Electric must invest manpower, materials, and financial resources to check and collate these numbers. This often causes a number disorder. This problem is studied and analyzed by the SIPOC model, as shown in Figure 9.

Figure 9 shows several risks in the material record and consumption of D Electric. First, the customs record number can be confused with the record number of D Electric. There are many options for the customs record number. This can cause the same enterprise record number to correspond to multiple customs records. Second, in the presence of more imported materials, it is prone to a lack of record information or the continued use of the old record number. This results in an idle new record number. Third, customs allows different enterprise record numbers to be placed in the same customs record number. However, D Electric does not have the relevant management process to ensure the continuity of an enterprise record number. This will lead to a crosstalk between the customs record number and enterprise record number. The current task of D Electric is to achieve the enterprise record number and customs record number corresponding to the idle customs record number and

Figure 7. Flow rate statistics of procurement projects for D Electric, 2016-2018

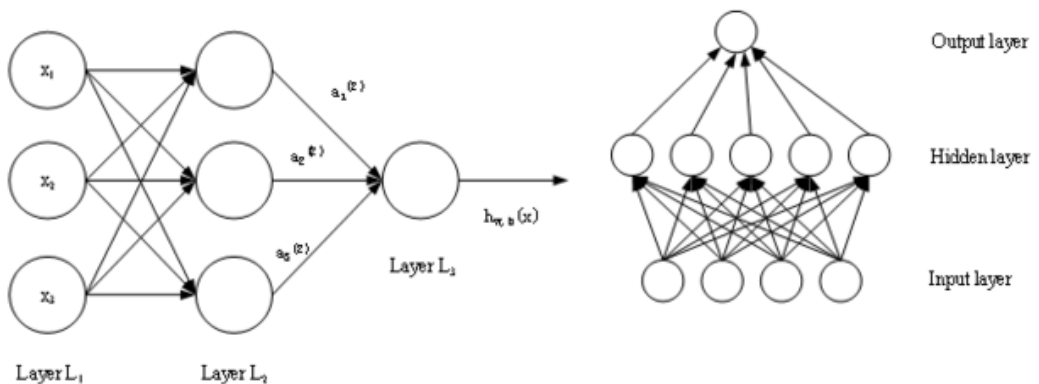

Figure 8. D Electric's material and service procurement turnover statistics, 2016-2018

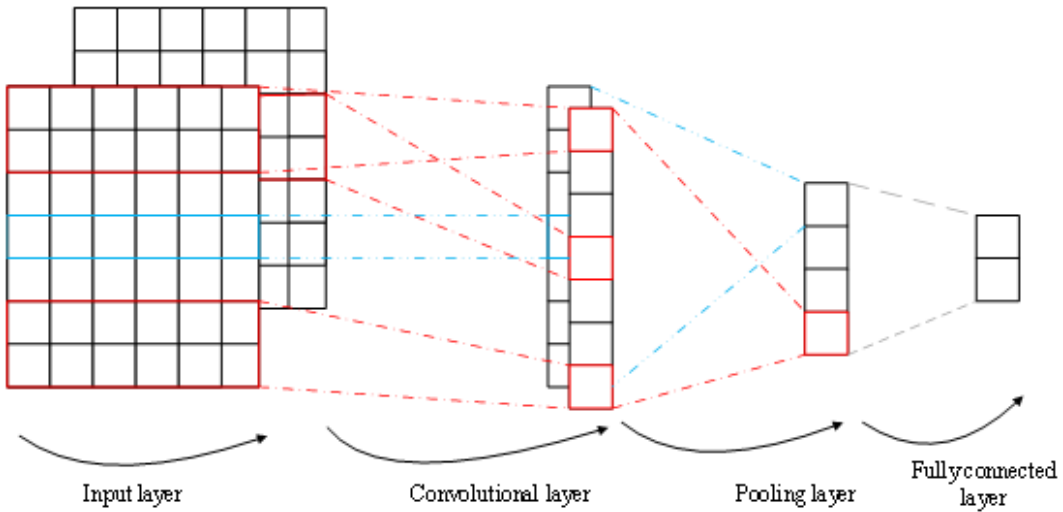
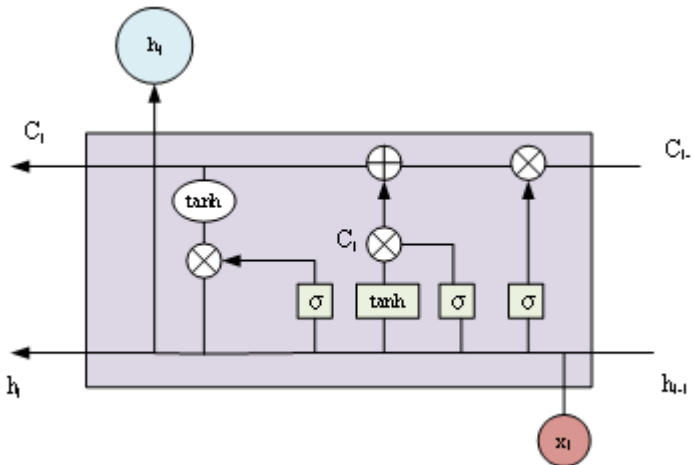

Figure 9. SIPOC model - D Electric material record and consumption



enterprise record number clearance. This leaves the import goods related to the record number. D Electric does a good job of unified docking with the customs department.

Delays also occurred when importing materials. Statistics on recent delay cycles address this issue, as shown in Table 2.

Table 2 shows that the delay period of import declarations is concentrated between 10 and 15 days (with 17 occurrences). There are six occurrences for delay periods over 15 days. There are two occurrences for delay periods less than 10 days. According to the table, the delay of imported materials is relatively serious, which has a negative impact on the scientific and technological research progress of D Electric. Figure 10 illustrates the relevant process of the import delay.

Figure 10 shows the complexity of the supply chain and management process. The material requirements of D Electric's production are automatically generated purchase orders through enterprise resource planning (ERP). However, the ERP system does not share information with the

Table 2. Statement of period extension of imported materials for D Electric

Delay days	Frequency of occurrence
Less than 10 days	2
10 to 15 days	17
Over 15 days	6

Figure 10. SIPOC model - Supply chain and management process of D Electric

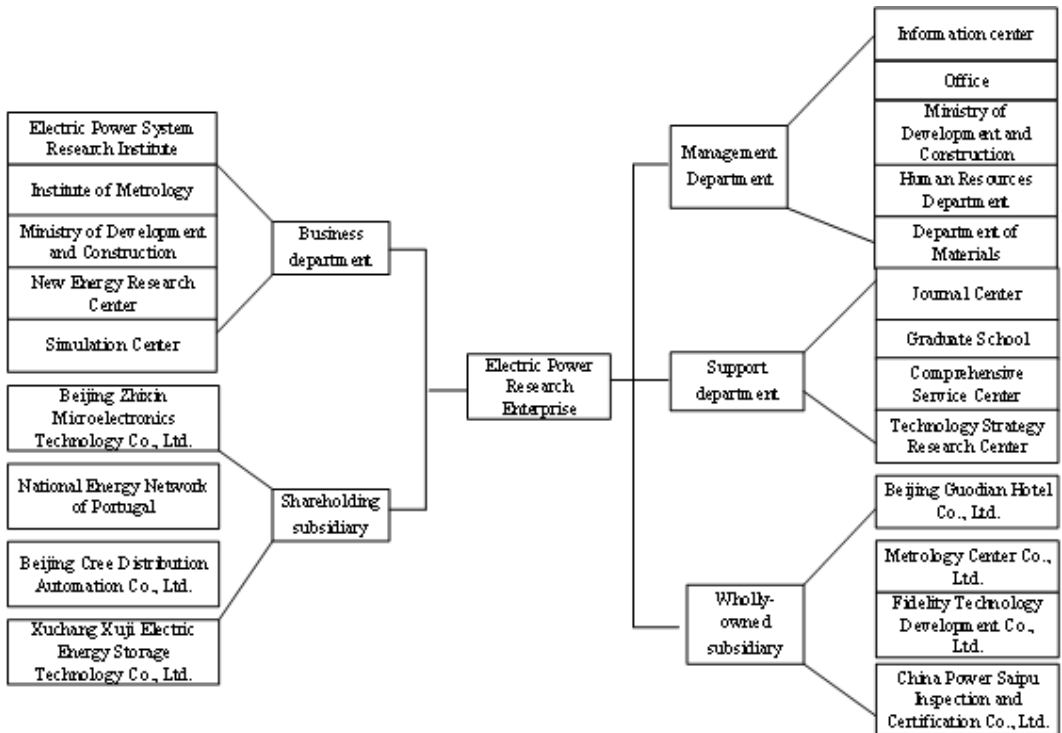

customs declaration office. The material requirements generated automatically through ERP run in the enterprise; therefore, it cannot be transmitted directly to the customs declaration office. This can result in information omissions, information errors, or information conversion errors.

In summary, the annual procurement volume of D Electric is increasing. However, there are a series of problems in its management process. For example, the purchasing management process is complex and fuzzy. Prior procurements had unclear objectives, vague ideas, and suppliers separate from the enterprise (lack of a unified whole). The purchasing management process is not related to the enterprise’s overall strategy.

Deep Learning and SIPOC on the Enterprise Procurement Management Process

The current purchasing management of D Electric was analyzed. If the enterprise does not change the traditional purchasing scheme, it will cause risks to the company and serious consequences to long-term developments. Deep learning and the SIPOC model have an important strategic position in the procurement process management of enterprises. The proposed method uses the Scrapy framework

Table 3. Examples of supplier information collection

Enterprise Name	Nature of Business
Supplier procurement of personal insurance Department of Anshan Branch of China Life Insurance Co., Ltd	Personal care supplies, cleaning supplies, food, and miscellaneous items
China Post Express Logistics Co., Ltd. Hangzhou Branch	Purchase of 10 column gas bags, eight column gas bags, and seven column gas bags
Bank of China Limited Fuzhou Cangshan sub-branch	Fuzhou Puding sub-branch security engineering procurement project
China Post Group Co., Ltd. Pingliang branch	Sunstroke prevention and labor protection procurement project in 2021

of Python language to identify suppliers with similar procurement requirements for D Electric (see Table 3).

Table 3 provides the company name and business scope of relevant suppliers. At least one company can be selected as a supplier of D Electric. The company’s recent operation can be found by using the company names. It also provides the evaluation, reputation, and material quality of enterprises on this supplier. This method can liberate the workload of buyers, as well as accurately and quickly find suppliers that meet the requirements of D Electric.

Deep learning has a risk warning effect on the procurement management of enterprises in the e-commerce environment. The risk early warning analysis of D Electric can help the company solve a series of problems in the procurement process. In a variety of early warning indicators, 10 indicators were selected as the research sample. The specific early warning indicators are shown in Figure 11.

From Figure 11, the net profit margin of total assets and growth rate of operating income in 2017 are negative, indicating that D Electric has poor management and low management levels compared

Figure 11. D Electric's early warning index

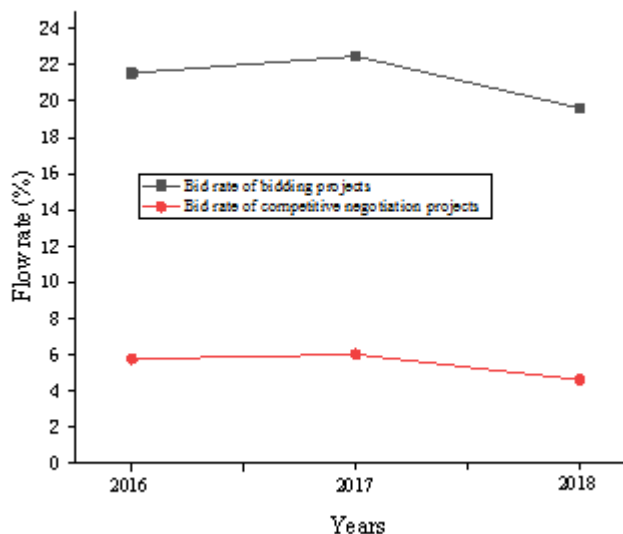

with companies in the same industry in the market this year. Improvements were noted in 2018 and 2019; however, negative values also existed. D Electric’s operation ability is general in these three years. A risk crisis is possible in 2017. The simulation output results are shown in Table 4.

The data from 2017 to 2019 shows that the output value of risk prediction is 1. This indicates a very likely risk crisis of D Electric. The procurement management process of the enterprise is one cause of the crisis. The procurement process is cumbersome, the material delay is serious, and the error probability is large. Therefore, it is urgent to make corresponding adjustments to the procurement process according to the actual situation of D Electric.

D Electric is prone to confusion between the customs record number and enterprise record number when importing materials. The SIPOC model is used to optimize the material record and consumption of D Electric. The results are shown in Figure 12.

Unlike traditional material filing and consumption, the content management system (CMS) is added to the optimized SIPOC model. The corresponding relationship between D Electric and the optimization of enterprise record number and customs record number is established through the continuous amplification of the CMS function. This process achieves “dedicated” and “one-to-one correspondence” effects.

Delays in imported materials have brought many problems to D Electric. It has also indirectly hindered the normal progress of provinces and scientific and technological research. In view of this,

Table 4. Verification of simulation output

Forecast year	2017	2018	2019
Output results	1	1	1
Correct or not	Crisis	Crisis	Crisis

Figure 12. SIPOC model - D Electric material recording and consumption optimization scheme

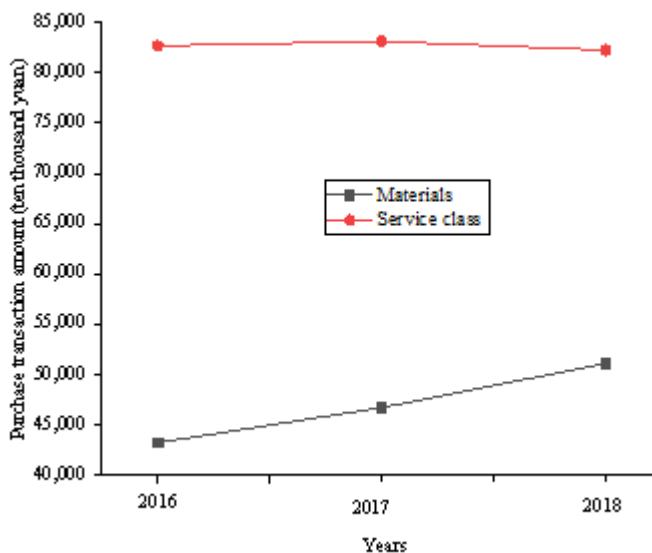

the SIPOC model is used to optimize the supply chain and management process of D Electric. The results are shown in Figure 13.

A comparison of the old and new models of supply chain and management processes in D Electric show changes in the new model. The declaration of imported materials is divided into two stages. First, the materials needed by D Electric enter customs. Second, the materials' information is verified and the customs record number is classified. Finally, these materials are sent to D Electric. The process avoids inconsistent or nonstandard customs record numbers and enterprise record numbers. "Let the material enter customs and then report the information to the enterprise" achieved the initial goal of the SIPOC model (the overall consistency principle between suppliers and customers). Relevant personnel are involved in the whole process and the problem can be solved the first time. In addition, "let the material enter customs and then report the information to the enterprise" appears to waste time at the customs office. In fact, the record number of customs has its own management process. This does a good job of labeling correspondence and tracks the logistics dynamics of materials to achieve the correct tracking of the record number.

Table 5 shows D Electric's imported material delay status.

A comparison of Tables 3 and 5 show that the SIPOC model optimizes the material cycle delay and promotes the adoption of the "let the material enter customs and then report the information to the enterprise" mode. Although "zero delay" is not completely realized, the delay period has improved. The previous delay period is concentrated in 10 to 15 days with a frequency of 17. Now, the delay period is concentrated in less than five days with a frequency of 14. The frequency of 10 to 13 days is two. Thus, the SIPOC model for D Electric procurement management process problems have great improvement.

Figure 13. SIPOC model – "Let the material enter customs and then report the information to the enterprise"

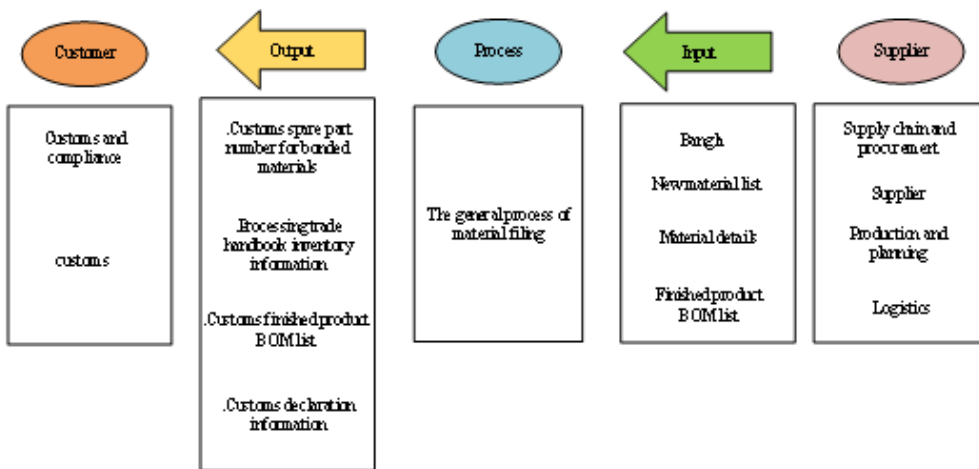

Table 5. D Electric imported material delay status

Delay days	Frequency of occurrence
Less than 5 days	14
5 to 10 days	9
10 to 13 days	2

CONCLUSION

The rapid development of e-commerce has a broad prospect for the development of enterprises. However, it has also led to problems. D Electric is used as the research sample in the e-commerce environment. The deep learning algorithm and the SIPOC model are used to analyze and study the procurement management process of the enterprise. The following conclusions are drawn. First, there are a series of problems in the procurement management process of D Electric. These include the complexity and ambiguity of the procurement management process, lack of clear objectives before procurement, and unclear ideas. The enterprise procurement management process of D Electric separates suppliers from the enterprise. It does not form a unified whole. The enterprise procurement management process of D Electric does not associate the enterprise procurement management process with the overall strategy of the enterprise. Second, deep learning plays an important role in enterprise risk early warning. The procurement management process of D Electric was analyzed from 2017 to 2019. It found that the problems in the procurement management process will affect the financial level of the entire enterprise. Adjusting the purchasing management process is an important task of the company. Third, the SIPOC organizational system model can optimize the material record and consumption scheme of D Electric. The optimized process can make the customs record number and enterprise record number realize the effect of “special purpose” and “one-to-one correspondence.” Fourth, after the analysis of the supply chain and management process of D Electric by the SIPOC model, the “let the material enter customs and then report the information to the enterprise” model is proposed. This can shorten the delay time from 10 to 15 days to less than 5 days. In addition, it can form a whole for suppliers and enterprises. The problems encountered can, therefore, be solved more efficiently.

Due to limited time, this study’s limitations in data acquisition may result in deviations in the test of risk. This study has not discussed the economic benefits of the enterprise procurement management process. A subsequent benefit evaluation can be carried out according to the specific situation. In turn, suggestions and opinions can promote the long-term and stable development of the enterprise procurement management process.

FUNDING

This research was supported by the project of “Executives’ Dynamic Relationship Network, System Differences, and Chinese Enterprises’ Internationalization Strategy: Internal Mechanism and Empirical Test” (Grant No.: 21NDJC144YB) (2021 Philosophy and Social Science Project of Zhejiang Province).

This research was supported by the project of “Research on the dynamic evolution mechanism of network public opinion of public emergencies and the ability of local governments to cope with them” (Grant No.: 21wsk169) (Wenzhou Philosophy and Social Science Planning in 2021).

This research was supported by the second batch of industry-University Collaborative Education Program of The Higher Education Department of the Ministry of Education in 2021 with project name of “Smart Enterprise Business Data Analysis and Operation Decision Teaching Ability Improvement Teacher Training Project” (Grant no. 202102586003).

REFERENCES

- Ancarani, A., & Capaldo, G. (2005). Supporting decision-making process in facilities management services procurement: A methodological approach. *Journal of Purchasing and Supply Management*, 11(5-6), 232–241. doi:10.1016/j.pursup.2005.12.004
- Cerqueus, T., Bonnaud, J., Dashkov, O., & Morin, E. (2020). Thesaurus matching in electronic commerce. *Electronic Commerce Research*, 1–26. doi:10.1007/s10660-020-09438-9
- Chengjun, L., Jianping, Z., & Jianhua, J. (2019). County-level logistics spatial linkage and network structure under the electronic commerce environment in Zhejiang Province. *Dili Kexue*, 39(11), 1719–1728.
- Deng, L., & Zhao, Y. (2022). Investment lag, financial constraints and company value—Evidence from China. *Emerging Markets Finance & Trade*, 1–14. doi:10.1080/1540496X.2021.2025047
- He, Y., Dai, L., & Zhang, H. (2020). Multi-branch deep residual learning for clustering and beamforming in user-centric network. *IEEE Communications Letters*, 24(10), 2221–2225. doi:10.1109/LCOMM.2020.3005947
- Lei, Z. (2020). Research and analysis of deep learning algorithms for investment decision support model in electronic commerce. *Electronic Commerce Research*, 20(2), 275–295. doi:10.1007/s10660-019-09389-w
- Liu, A., Osewe, M., Shi, Y., Zhen, X., & Wu, Y. (2021). Cross-border e-commerce development and challenges in China: A systematic literature review. *Journal of Theoretical and Applied Electronic Commerce Research*, 17(1), 69–88. doi:10.3390/jtaer17010004
- Liu, F., Zhang, G., & Lu, J. (2020a). Heterogeneous domain adaptation: An unsupervised approach. *IEEE Transactions on Neural Networks and Learning Systems*, 31(12), 5588–5602. doi:10.1109/TNNLS.2020.2973293
- Liu, Y., Chen, D. Q., & Gao, W. (2020b). How does customer orientation (in) congruence affect B2B electronic commerce platform firms' performance? *Industrial Marketing Management*, 87, 18–30. doi:10.1016/j.indmarman.2020.02.027
- Liu, Z., Fang, L., Jiang, D., & Qu, R. (2022). A machine-learning based fault diagnosis method with adaptive secondary sampling for multiphase drive systems. *IEEE Transactions on Power Electronics*. Advance online publication. doi:10.1109/TPEL.2022.3153797
- Meng, F., Cheng, W., & Wang, J. (2021). Semi-supervised software defect prediction model based on tri-training. *Transactions on Internet and Information Systems (Seoul)*, 15(11), 4028–4042. doi:10.3837/tiis.2021.11.009
- Pochynok, N., Muravskiy, V., & Farion, V. (2021). Implementation of electronic communications in accounting of public procurement. *Technology Audit and Production Reserves*, 4(4), 60. doi:10.15587/2706-5448.2021.238858
- Sitar-Tăut, D. A., & Mican, D. (2020). MRS OZ: Managerial recommender system for electronic commerce based on Onicescu method and Zipf's law. *Information Technology Management*, 21(2), 131–143. doi:10.1007/s10799-019-00309-w
- Westland, J. C. (2020). Introduction to the special issue: Electronic commerce in social networks. *Electronic Commerce Research*, 20(1), 1–1. doi:10.1007/s10660-020-09407-2
- Wu, X., Zheng, W., Chen, X., Zhao, Y., Yu, T., & Mu, D. (2021). Improving high-impact bug report prediction with combination of interactive machine learning and active learning. *Information and Software Technology*, 133, 106530. doi:10.1016/j.infsof.2021.106530
- Wu, Z., Song, A., Cao, J., Luo, J., & Zhang, L. (2017). Efficiently translating complex SQL query to mapreduce jobflow on cloud. *IEEE Transactions on Cloud Computing*, 8(2), 508–517. doi:10.1109/TCC.2017.2700842
- Xia, H., Wei, X., An, W., Zhang, Z. J., & Sun, Z. (2021). Design of electronic-commerce recommendation systems based on outlier mining. *Electronic Markets*, 31(2), 295–311. doi:10.1007/s12525-020-00435-2
- Yang, W., Chen, X., Xiong, Z., Xu, Z., Liu, G., & Zhang, X. (2021a). A privacy-preserving aggregation scheme based on negative survey for vehicle fuel consumption data. *Information Sciences*, 570, 526–544. doi:10.1016/j.ins.2021.05.009

- Zheng, W., Liu, X., Ni, X., Yin, L., & Yang, B. (2021a). Improving visual reasoning through semantic representation. *IEEE Access : Practical Innovations, Open Solutions*, 9, 91476–91486. doi:10.1109/ACCESS.2021.3074937
- Zheng, W., Xun, Y., Wu, X., Deng, Z., Chen, X., & Sui, Y. (2021b). A comparative study of class rebalancing methods for security bug report classification. *IEEE Transactions on Reliability*, 70(4), 1658–1670. doi:10.1109/TR.2021.3118026
- Zheng, W., Zhou, Y., Liu, S., Tian, J., Yang, B., & Yin, L. (2022). A deep fusion matching network semantic reasoning model. *Applied Sciences (Basel, Switzerland)*, 12(7), 3416. doi:10.3390/app12073416
- Zhong, H., Zhang, S., Song, W., & Zhang, Z. (2021). Impact of international trade on cross-border e-commerce development: An empirical study based on the evidence from Ningbo city in China. *International Journal of Technology, Policy and Management*, 21(2), 140–156.
- Zhu, M. (2021). Implementation of support-vector machine algorithm to develop a model for electronic commerce energy regulatory system. *Energy Reports*, 7, 2703–2710. doi:10.1016/j.egy.2021.05.009