

The influence of motor re-acceleration on voltage sags

Citation for published version (APA):

Bollen, M. H. J. (1995). The influence of motor re-acceleration on voltage sags. *IEEE Transactions on Industry Applications*, 31(4), 667-674. <https://doi.org/10.1109/28.395271>

DOI:

[10.1109/28.395271](https://doi.org/10.1109/28.395271)

Document status and date:

Published: 01/01/1995

Document Version:

Publisher's PDF, also known as Version of Record (includes final page, issue and volume numbers)

Please check the document version of this publication:

- A submitted manuscript is the version of the article upon submission and before peer-review. There can be important differences between the submitted version and the official published version of record. People interested in the research are advised to contact the author for the final version of the publication, or visit the DOI to the publisher's website.
- The final author version and the galley proof are versions of the publication after peer review.
- The final published version features the final layout of the paper including the volume, issue and page numbers.

[Link to publication](#)

General rights

Copyright and moral rights for the publications made accessible in the public portal are retained by the authors and/or other copyright owners and it is a condition of accessing publications that users recognise and abide by the legal requirements associated with these rights.

- Users may download and print one copy of any publication from the public portal for the purpose of private study or research.
- You may not further distribute the material or use it for any profit-making activity or commercial gain
- You may freely distribute the URL identifying the publication in the public portal.

If the publication is distributed under the terms of Article 25fa of the Dutch Copyright Act, indicated by the "Taverne" license above, please follow below link for the End User Agreement:

www.tue.nl/taverne

Take down policy

If you believe that this document breaches copyright please contact us at:

openaccess@tue.nl

providing details and we will investigate your claim.

The Influence of Motor Reacceleration on Voltage Sags

Math H. J. Bollen, *Member, IEEE*

Abstract—The assumption that a voltage sag is rectangular is not correct in a system with large induction motor loads. The motors decelerate during the short circuit. After fault-clearing they will accelerate again, drawing a high reactive current from the supply, causing a prolonged postfault voltage sag. This is aggravated by the removal of branches by the protection.

The resulting shape of some voltage sags in an example system is shown and discussed. For the example system, a stochastic voltage sag table is determined. This table gives the expected number of sags of different depth and duration. The influence of faster protection and of reduced transformer impedance on the table is presented.

A simple motor model is implemented in a method for including interruptions due to voltage sags in the reliability analysis of power systems. This model is presented briefly and used to show the influence of motor parameters on the number of sags that lead to an interruption of plant operation.

I. INTRODUCTION

SHORT-DURATION voltage sags due to short circuits are recognized as an important power quality problem. In particular, electronic equipment like computers, adjustable-speed drives and process-control systems are extremely sensitive. Despite this recognition, not much work has been published on the shape of voltage sags, nor on their stochastic assessment.

A simple method for assessing the number of sags experienced by a customer is presented in [1]. This method is proposed to become part of the IEEE Recommended Practice for the Design of Reliable Industrial and Commercial Power Systems [2]. A detailed stochastic method for including interruptions due to voltage sags in the reliability analysis of power systems is presented in [3].

Calculation of depth and duration of a sag is in both methods based on two simple assumptions:

- 1) Due to the short circuit, the voltage drops to a low value immediately.
- 2) When the fault is cleared, the voltage recovers immediately.

These assumptions, however, do not hold in the case of a substantial part of the load consisting of electrical motors like in many industrial power systems. During the short circuit, the motors will slow down. Their reacceleration after the fault will increase the load current and thus prolong the voltage sag.

Paper ICPSD 94-55, approved by the Power Systems Engineering Committee of the IEEE Industry Applications Society for presentation at the 1994 IEEE Industry Applications Society Annual Meeting, Denver, CO, October 2-7. Manuscript released for publication January 27, 1995.

The author is with the Manchester Centre for Electrical Energy, University of Manchester Institute of Science and Technology, Manchester M60 1QD, U.K.

IEEE Log Number 9411436.

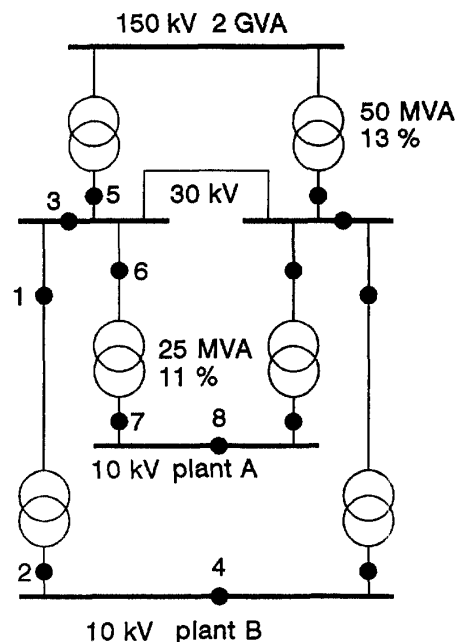

Fig. 1. Example power system. The numbers give fault positions for which voltage sags have been calculated.

Several authors mention the influence of voltage sags on motor behavior or voltage sags due to motor starting, but not the influence of motors on voltage sags due to short circuits. El-Sadez [4] shows that certain combinations of motor parameters and fault-clearing time can lead to a situation in which the voltage does not recover any more. This could be considered as a prolonged voltage sag. The occurrence of these situations is however quite rare. The stable situation, in which the voltage recovers slowly, is of more importance. The influence of motors on the shape of voltage sags is discussed in some detail by Das [5].

This paper will discuss some of the aspects of the influence of induction motors on voltage sags. The shape of the voltage sags will be discussed in Section II for a few fault positions in an example system. A more complex system is presented in [6]. In Section III, some stochastic properties of voltage sags as experienced by the plants in the example system are presented. A simple induction motor model has been incorporated in the reliability analysis method presented in [3]. This model is discussed in Section IV and used in Section V to compare the expected number of sags in a few alternatives for the supply to two plants.

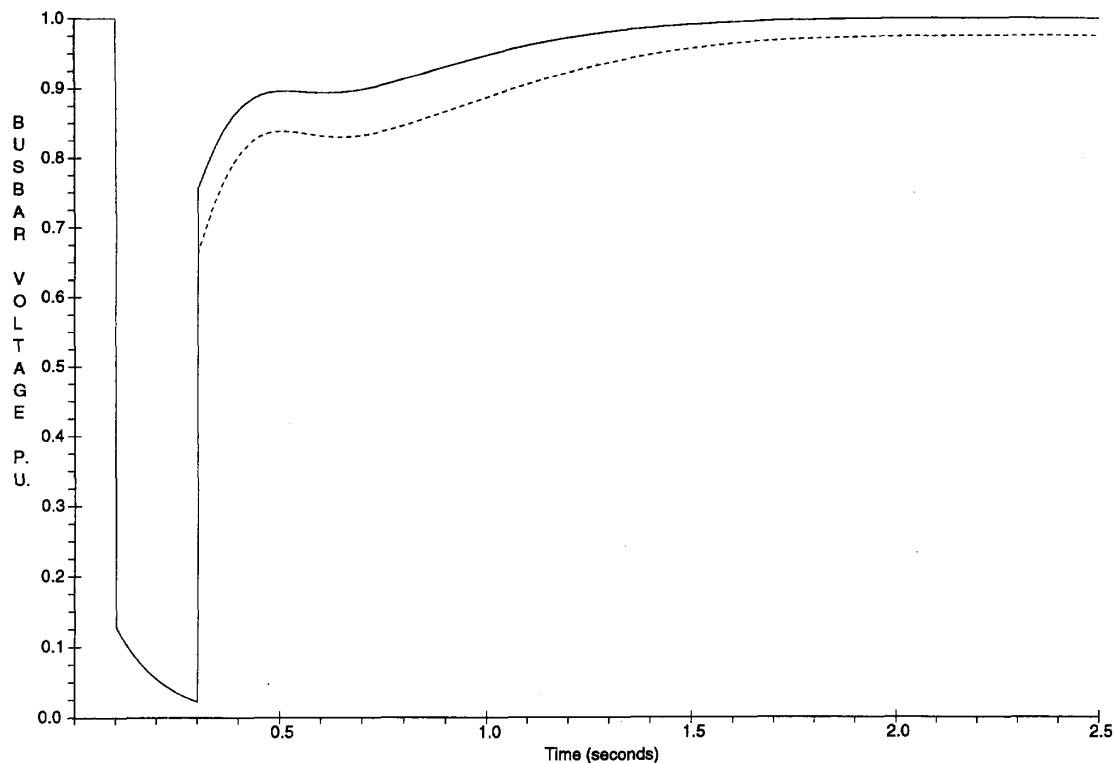

Fig. 2. Voltage sag for a fault at position 1.

II. SHAPE OF THE VOLTAGE SAG

To show the influence of induction motors on the shape and the duration of voltage sags, the behavior of the industrial distribution system shown in Fig. 1 has been simulated for the short circuit positions indicated. Four of them will be discussed in detail below:

- 1) on the high-voltage side of a 30/10-kV transformer,
- 2) on the low-voltage side of a 30/10-kV transformer,
- 3) on a 30 kV bus, and
- 4) on a 10 kV bus.

Both plants contain six induction motors, all of these are rated at 2.8 MW, 3.355 MVA. The following equivalent circuit parameters have been used for the motors (rated to machine MVA):

mechanical time constant	5.3 s,
magnetizing reactance	5.8 p.u.,
stator resistance	0.007 p.u.,
stator reactance	0.2 p.u.,
inner cage rotor resistance	0.01 p.u.,
inner cage rotor reactance	0.097 p.u.,
outer cage rotor resistance	0.06 p.u., and
outer cage rotor reactance	0.033 p.u.

These values have been derived from manufacturer's data for a 10-kV, 2.8-MW induction motor. The impedance of the cables has been neglected. The transformers as well as the 150-kV supply are represented by their short-circuit impedances. All faults are three-phase short circuits.

The fault-clearing time is 200 ms, except for the short circuit on the 10-kV bus, for which it is 600 ms. The simulations use the transient analysis program within the IPSA package [7]. Some of the results of these simulations are shown in the figures in this section, where solid lines refer to plant A and dotted lines to plant B.

Figs. 2 and 3 show bus voltage and induction machine slip due to a short circuit of 200 ms on high-voltage side of a 30/10-kV transformer (position 1 in Fig. 1). Since the impedance of the cables has been neglected, both plants will show the same during-fault behavior. The induction machines temporarily operate as generators, causing a nonzero during fault voltage. After the fault, plant B will be supplied through one transformer and plant A through two. Because of this the postfault voltage at plant B is lower than that at plant A. For the same reason it will take longer for the motor in plant B to reach its stable speed.

Neglecting the induction motor behavior (as done in [1] and [3]) would lead to the voltage going immediately down to zero at fault initiation (0.1 s) and immediately back to 1 p.u. at fault clearing (0.3 s). Due to the motor load, the voltage is higher during the fault and lower after the fault.

We see from Fig. 3 that the maximum slip is reached more than 100 ms after fault clearing. It simply takes that long before the power system is able to supply more power to the machine than the prefault value. For plant B (fed through one transformer) this takes longer than for plant A (fed through two transformers).

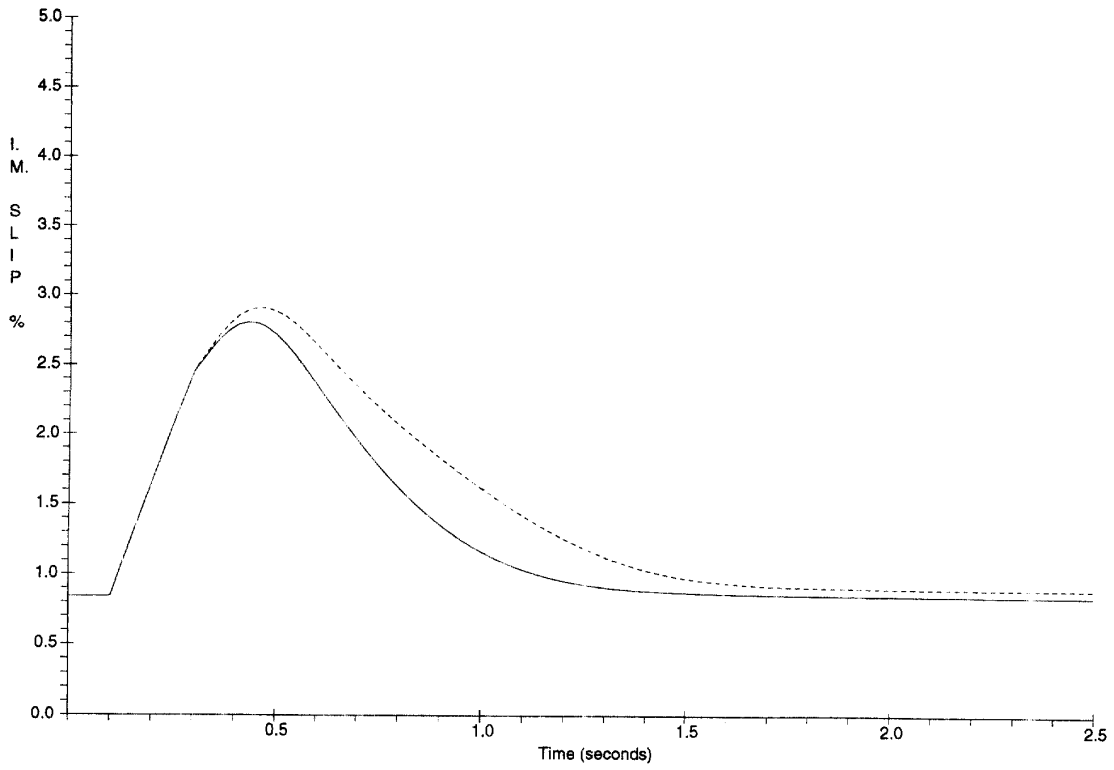

Fig. 3. Induction machine slip for fault at position 1.

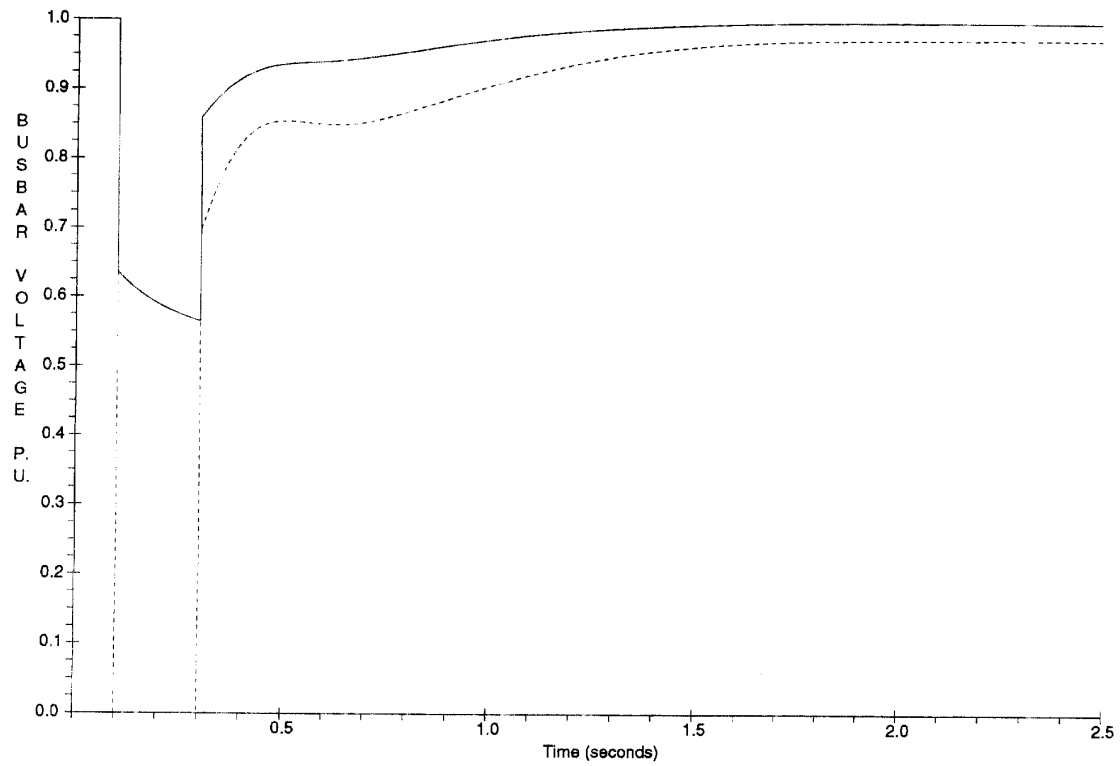

Fig. 4. Voltage sag for a fault at position 2.

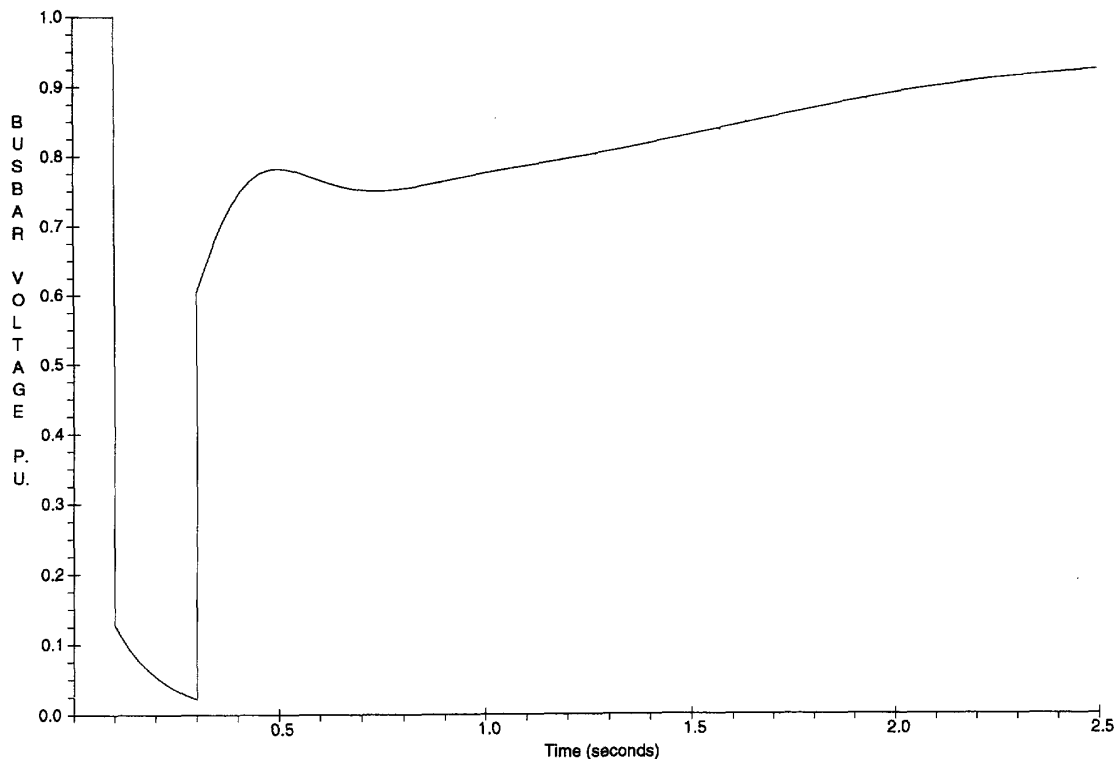

Fig. 5. Voltage sag for a fault at position 3.

Fig. 4 shows voltage during and after a short circuit on the low-voltage side of a 30/10-kV transformer (position 2). During the fault, plant A experiences a considerably less reduction in voltage than plant B. (As cable impedance has been neglected, the plant voltage for plant B is zero). This causes the motor in plant A to slow down less than the one in plant B. After the fault, the current drawn by plant A will be less than in situation 1, which significantly reduces the sag for plant A and slightly reduces it for plant B.

Fig. 5 shows the voltage sag for a short circuit on the 30-kV bus (position 3). During the fault, the voltages are identical to those in case 1 (see Fig. 2), but after the fault both plants have to be supplied through one 150/30-kV transformer. This causes a severe postfault voltage sag. An interesting phenomenon is that the postfault voltage starts to decrease again about 200 ms after the fault. This was also visible for previous fault positions, but not as clear as here. The voltage decrease is due to the increased current taken by the motor when it starts to accelerate again, which is approximately 200 ms after fault clearing.

Fig. 6 shows the voltage sag for a short circuit on a 10-kV bus (position 4). The fault is cleared by the overcurrent relays, 600 ms after fault initiation. Only the sag for plant A is shown. Plant B will experience a sustained interruption. The during-fault voltage of plant A is relatively high (similar to situation 2, Fig. 4), but the longer duration of the fault (600 ms) causes a deceleration about equal to the one in situations 1 and 3. After the fault, plant B is no longer drawing

current. Also, both transformers to plant A are available for the power transport. Because of this the postfault sag at plant A is fairly small. The slip immediately starts to decrease at fault-clearing and the voltage does not show any postfault minimum.

III. STOCHASTIC PROPERTIES OF THE VOLTAGE SAGS

In general, a customer (an industrial plant in this case) will not be interested in the shape of individual voltage sags. What is of interest is whether the plant will experience an interruption of plant operation (IPO) or not. The relationship between the voltage sag shape and an IPO is still an unknown area. Simply assume that sensitivity is only related to depth and duration of a sag, i.e., an IPO will occur if the rms voltage stays below a certain minimum voltage for longer than a certain maximum time. Based on this assumption, it seems appropriate to calculate the probabilities that the sag exceeds certain depths and durations.

The failure rates assumed for each of the fault positions indicated in Fig. 1, are given in Table I. These are based on a literature search to obtain failure data in distribution systems [8]. The last column in the table shows the number of actual fault positions represented. For example, fault position 3 represents a fault on any of the two 30-kV buses. The resulting number of sags has therefore been multiplied by two.

For each of the fault positions, the shape of the voltage sag has been calculated. These shapes, plus the data from Table I, have been used to obtain the expected number of sags per

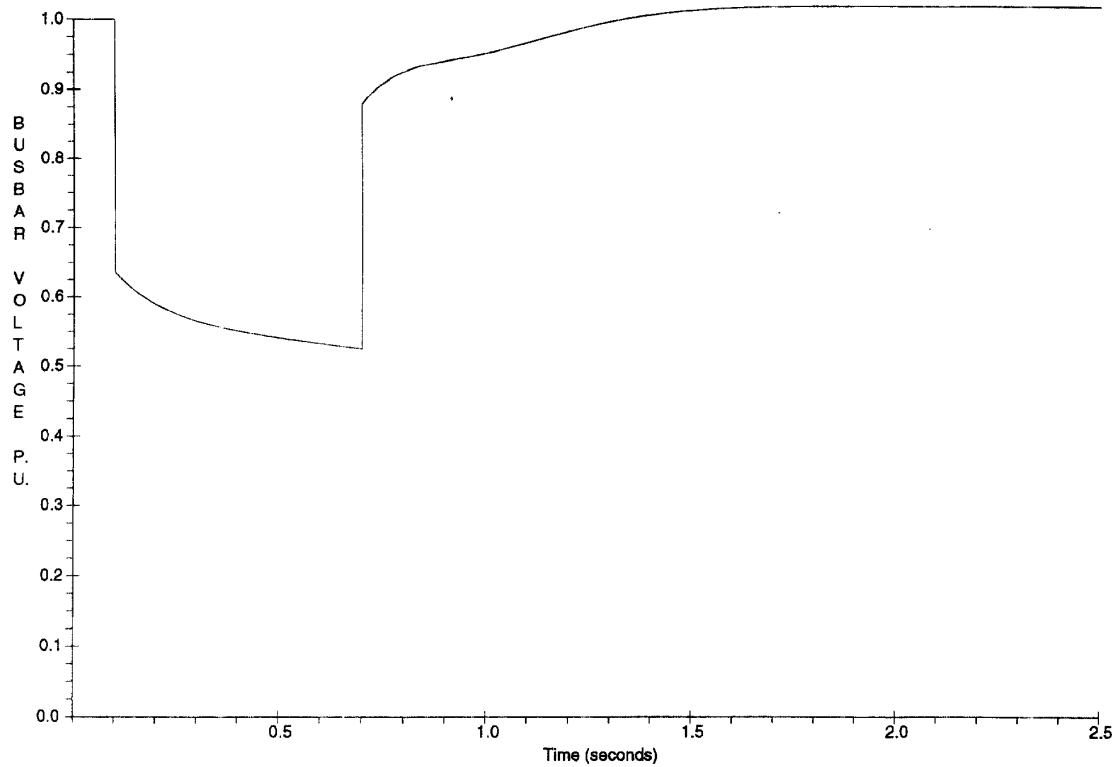

Fig. 6. Voltage sag for a fault at position 4.

TABLE I
THE FAILURE RATES FOR THE VARIOUS FAULT POSITIONS

fault position	failure rate	actual positions
1	0.03 yr ⁻¹	2
2	0.01 yr ⁻¹	2
3	0.002 yr ⁻¹	2
4	0.01 yr ⁻¹	1
5	0.015 yr ⁻¹	2
6	0.03 yr ⁻¹	2
7	0.01 yr ⁻¹	2
8	0.01 yr ⁻¹	1

TABLE II
STOCHASTIC VOLTAGE SAG TABLE: EXPECTED NUMBER OF INTERRUPTIONS OF PLANT OPERATION FOR VARIOUS LOAD SENSITIVITIES

minimum voltage	maximum duration				
	250 ms	500 ms	750 ms	1000 ms	1250 ms
90%	0.204+X	0.184+X	0.114+X	0.034+X	0.004+X
85%	0.184+X	0.124+X	0.034+X	0.004+X	0.004+X
80%	0.124+X	0.014+X	0.004+X	0.004+X	X
75%	0.104+X	0.01+X	X	X	X
70%	0.014+X	0.01+X	X	X	X
65%	0.01+X	0.01+X	X	X	X
60%	0.01+X	0.01+X	X	X	X

year exceeding certain depths and durations. The results are shown in the Tables II-IV. Starting from a table with zeros, the product of failure rate and actual number of fault positions is added to a table entry if the sags is below the corresponding depth for longer than the corresponding duration.

Table II gives the stochastic voltage sag table for plant A. Since the system is symmetrical, this table also applies to plant B. It is important to remember that this is a cumulative table. This is clearly visible from the term X: the expected number of sustained interruptions. In this case $X = 0.01 \text{ yr}^{-1}$, which is the failure rate of the plant bus. A sustained interruption can be viewed as a sag longer and deeper than any of the entries in the table.

Under the assumption of "rectangular sensitivity" as discussed above, the stochastic voltage sag table gives the ex-

pected number of IPO's for various load sensitivities (expressed as a minimum voltage and a maximum duration). Note that it is no longer possible to give the number of sags of a given duration and depth.

By considering Table II, it follows that plant A can expect about once in five years (0.204 times per year) a sag below 85% for more than 250 ms. If the equipment in the plant can only withstand an 85% bus voltage for 250 ms, it will experience an IPO once in five years.

Table III gives the same information as Table II. (The table again applies to plant A as well as to plant B). But in this case the fault-clearing time is only half of its previous value. The induction machines have less time to slow down, and will thus need less time to speed up again. This results in shorter postfault sags. The during-fault sags are of course also shorter.

TABLE III
STOCHASTIC VOLTAGE SAG TABLE WITH FASTER FAULT-CLEARING TIME

minimum voltage	maximum duration				
	250 ms	500 ms	750 ms	1000 ms	1250 ms
90%	0.124+X	0.034+X	0.004+X	0.004+X	X
85%	0.014+X	0.004+X	X	X	X
80%	0.01+X	X	X	X	X
75%	0.01+X	X	X	X	X
70%	0.01+X	X	X	X	X
65%	0.01+X	X	X	X	X
60%	0.01+X	X	X	X	X

Table IV shows the expected number of sags in case the impedance of the 30/10-kV transformers is reduced from 11% to 8%. The lower impedance will reduce the voltage drop due to the inrush current (thus reducing the depth of the sag), which enables the motors to take in more power from the supply. This results in a shorter postfault sag.

IV. THE MOTOR MODEL FOR STOCHASTIC ANALYSIS OF VOLTAGE SAGS

The way in which the stochastic voltage sag tables have been calculated in the previous section is rather time-consuming, especially for larger systems. Another restriction is that only first order events have been taken into account. Higher order effects like a short circuit during maintenance somewhere in the system or failure of the protection, might strongly influence the number of deep sags, as well as the number of sustained interruptions.

In a previous paper [3], the author presents a method for including interruptions due to voltage sags in the reliability analysis of power systems. It could equally be considered as a method for stochastic analysis of voltage sags.

The method, implemented in a computer program, consists of:

- 1) a Monte Carlo simulation to generate stochastic times of occurrence for events like a short circuit,
- 2) an electric circuit to calculate load node voltages due to these events, and
- 3) a maximum-permissible voltage sag for each load node, which is used as the interruption criterion.

This computer program has been updated with an induction motor model. The influence of the induction motor loads on the shape of the voltage sags is taken into account now. The voltage sag is no longer assumed to be rectangular.

From the widely used equivalent scheme for the induction machine (with slip-dependent resistance) the motor impedance Z as a function of slip s can be approximated through the following expression (stator resistance has been neglected):

$$Z = |Z_n| \frac{1 + j \frac{s}{s_p}}{j \sqrt{\sigma} \left(1 + j \frac{s}{\sigma s_p} \right)} \quad (1)$$

with $|Z_n|$ the absolute value of the impedance in nominal load, s_p the pull-out slip, and σ the leakage factor. Nominal load is defined as the load leading to maximum power factor.

TABLE IV
STOCHASTIC VOLTAGE SAG TABLE WITH REDUCED TRANSFORMER IMPEDANCES

minimum voltage	maximum duration				
	250 ms	500 ms	750 ms	1000 ms	1250 ms
90%	0.204+X	0.124+X	0.094+X	0.034+X	0.004+X
85%	0.184+X	0.044+X	0.004+X	0.004+X	X
80%	0.104+X	0.014+X	0.004+X	X	X
75%	0.014+X	0.01+X	X	X	X
70%	0.01+X	0.01+X	X	X	X
65%	0.01+X	0.01+X	X	X	X
60%	0.01+X	0.01+X	X	X	X

The stochastic analysis method used is an event-based Monte Carlo simulation. The system is only observed at discrete times (e.g., fault initiation, fault clearing, repair of faulted component). In an event-based simulation it is normally assumed that nothing happens in between the events. This assumption is in accordance with the two assumptions mentioned in the introduction. But taking the motor behavior into account, we have to model the variation of the load impedance in between events. This required a slight adaptation of the event-based method.

In the event-based method, at each event instant the voltages at the load nodes V_{load} are calculated from the voltages at the generator nodes V_{gen} , through the following equation [3]:

$$V_{load} = Z_{load,gen} Z_{gen,gen}^{-1} V_{gen} \quad (2)$$

A change in any of the branch impedances leads to changes in the impedance matrices $Z_{load,gen}$ and $Z_{gen,gen}$. This is calculated by means of a Kron reduction. This Kron reduction turned out to be the main consumer of computer time during the simulation.

When an event occurs in the simulation, the slip is calculated as a function of time, for the interval between the previous event and the current event. As events can be years apart in a reliability study, the calculation is stopped when the slip no longer significantly changes. For many events, this happens within a few seconds. For some events (e.g., fault clearing, the previous event is fault initiation) the slip does not settle down in the limited time between the two events.

The slip is calculated by numerically solving the energy balance of the rotating mass (inertia) of the motor

$$\frac{ds}{dt} = \frac{T_L - T_e}{t_m} \quad (3)$$

where

$$T_L = M_{load} \left\{ \frac{1-s}{1-s_n} \right\}^2 \quad (3a)$$

is the mechanical load torque. The electrical torque is

$$T_e = \left\{ \frac{1+\sigma}{s} \frac{\sqrt{\sigma}}{s_p} + T_R s \right\} V^2 \quad (3b)$$

where V is the voltage at the motor terminals. The term $T_R s$ is included to represent the run-up cage.

TABLE V
NUMBER OF INTERRUPTIONS OF PLANT OPERATION
AS A FUNCTION OF MOTOR PARAMETERS

		$(s_k/100)$														
		1	2	3	4	5	6	7	8	9	10	11	12	13	14	15
t_m	3	14	12	10	3	3
	4	14	12	5	3
	5	14	10	3
	6	12	5	3
	7	12	5	3
	8	12	5
	9	12	3
	10	12	3	3
	11	12	3	3	3
	12	10	3	3	3	3	3
	13	10	3	3	3	3	3	3
	14	10	3	3	3	3	3	3	3
	15	10	3	3	3	3	3	3	3	3	3
	16	10	3	3	3	3	3	3	3	3	3

An improved Euler method (sometimes referred to as second-order Runge-Kutta method) has been used. The voltage in (3b) is calculated from (2) with the load impedance calculated from (1). The slip is calculated every millisecond. To save calculation time, the load impedance is only calculated once every 50 ms. Only if its value differs more than 5% from the previous value, the impedance matrix is adjusted and a new load node voltage is calculated.

The induction motor load is described through the following input parameters:

- 1) impedance in nominal load $Z_n = |Z_n|\{\cos \phi_n + j \sin \phi_n\}$,
- 2) pull-out slip s_p ,
- 3) load factor M_{load} ,
- 4) mechanical time constant t_m , and
- 5) run-up torque T_R .

The leakage factor σ is found from

$$\cos \phi_n = \frac{1 - \sigma}{1 + \sigma} \tag{4}$$

and the nominal slip s_n from

$$\frac{s_n}{s_p} = \sqrt{\sigma}. \tag{5}$$

V. EXAMPLE: INFLUENCE OF MOTOR PARAMETERS

The influence of motor parameters on the number of IPO's has been studied for the redundant supply to two large industrial plants, as shown in Fig. 1.

The following parameters have been used for the two plants:

- nominal load 20 MW,
- nominal power factor 0.8,
- pull-out torque 0.01-0.15,
- load factor 0.9,
- mechanical time constant 3-16 s, and
- run-up torque 1.0.

The dots in Fig. 1 indicate the short circuits that have been taken into account in the study. By using the above-described motor model, it has been determined how many of these 14 short circuits would lead to an IPO for plant A. The following

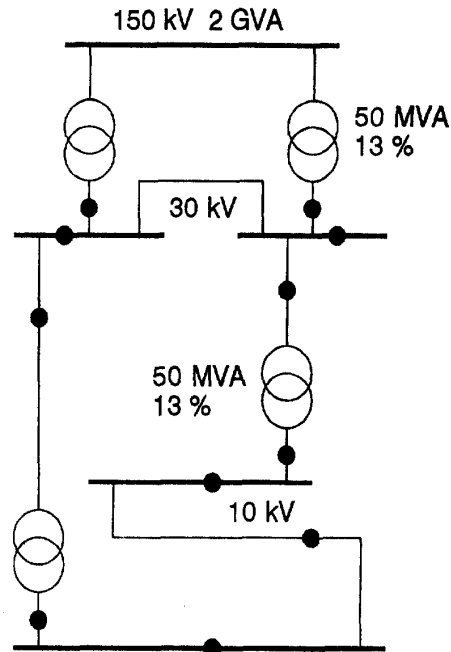

Fig. 7. Alternative redundant supply to two industrial plants.

interruption criterion has been used: The voltage should be back at 70% within 1 s and back at 90% within 1.5 s after the start of the voltage sag. Note that we are no longer restricted to rectangular sensitivity curves. As already mentioned in [3], any shape for the maximum-permissible sag can be taken into account.

The simulation has been repeated for different values of the pull-out torque and the mechanical time constant. The results are represented in Table V. It is important to note that the mechanical time constant is used to quantify the motor's inertia (the mechanical time constant is twice the inertia constant). In the area with the dots, only the short circuit at the plant bus will lead to an IPO. The voltage sags have no influence on the reliability. The number three indicates that a short circuit at one of the 30-kV buses will also lead to an IPO. This actually implies that it is of no use to install differential protection on the 30-kV buses. In the area shown bold, even short circuits in the transformer connections lead to IPO's. The connections are no longer redundant in such a case. Another system configuration should be considered, or the voltage sag withstand of the plants should be increased.

The load modelled in Section II and III, with $t_m = 5$ s and $s_k = 10\%$, turns out to lead to a reliable supply.

Fig. 7 shows an alternative network for the supply to the same two plants. In this case, the redundancy is obtained from a cable connection between the two plant buses. Although transformers of a higher power rating are needed, this structure will probably still be less expensive than the one in Fig. 1. But unfortunately, the voltage sags have a stronger influence on the reliability, as shown in Table VI. Only for low mechanical time constant and large pull-out torque, will the system be insensitive to voltage sags.

TABLE VI
NUMBER OF INTERRUPTIONS OF PLANT OPERATION
FOR THE ALTERNATIVE SUPPLY SYSTEM
($s_k/100$)

	1	2	3	4	5	6	7	8	9	10	11	12	13	14	15
3	11	11	10	8	4	4	2	2
4	11	11	10	4	4	2	2
5	11	11	4	4	3	3	2
6	11	10	4	4	4	3	2	2
7	11	10	4	4	4	3	3	2	2
8	11	10	4	4	3	3	3	2	2	2
9	11	4	4	4	3	3	3	3	3	2	2	2	2	.	.
10	11	4	4	4	3	3	3	3	3	3	2	2	2	2	.
11	11	4	4	3	3	3	3	3	3	3	3	3	2	2	2
12	11	4	4	3	3	3	3	3	3	3	3	3	3	3	3
13	11	4	4	3	3	3	3	3	3	3	3	3	3	3	3
14	10	4	4	3	3	3	3	3	3	3	3	3	3	3	3
15	10	4	4	3	3	3	3	3	3	3	3	3	3	3	2
16	10	4	3	3	3	3	3	3	3	3	3	3	3	3	2

TABLE VII
NUMBER OF INTERRUPTIONS OF PLANT OPERATION
FOR THE ALTERNATIVE SUPPLY: FASTER PROTECTION
($s_k/100$)

	1	2	3	4	5	6	7	8	9	10	11	12	13	14	15
3	11	10	4	2	2	2
4	11	4	3	2	2
5	11	4	4	3
6	10	4	4	3	2	2	2
7	10	4	4	3	3	2	2	2
8	10	4	4	3	3	3	3	2	2	2
9	10	4	4	3	3	3	3	3	2	2	2
10	4	4	3	3	3	3	3	3	2	2
11	4	4	3	3	3	3	3	3	2
12	4	4	3	3	3	3	3	2
13	4	4	3	3	3	3	3	2
14	4	4	3	3	3	3	3	2
15	4	4	3	3	3	3	3	2
16	4	3	3	3	3	3	3	2

In order to reduce the influence of voltage sags, two measures have been compared:

- 1) reducing the fault-clearing time to 100 ms;
- 2) installing 30/10 kV transformers with a short circuit impedance of only 10%.

The consequences for the number of interruptions are shown in Tables VII and VIII, respectively. In particular, reducing the short circuit voltage considerably increases the reliability.

VI. DISCUSSION AND CONCLUSIONS

We have seen in this paper how the deceleration and acceleration of motors influences duration and shape of voltage sags. The assumption of a rectangular sag no longer holds in case of large induction motor loads. During the fault, the voltage is increased by these loads, while the postfault voltage is temporarily decreased.

A new problem which becomes evident now is the definition of the voltage-sag shape. Previously a voltage sag was defined through its depth and its duration. As the sag was assumed to be rectangular, this was sufficient information. Taking motor behavior into account will make it no longer possible to define a sag simply by its duration and magnitude. This will also make it harder to compare sags with voltage withstand curves.

TABLE VIII
NUMBER OF INTERRUPTIONS OF PLANT OPERATION FOR THE
ALTERNATIVE SUPPLY: REDUCED TRANSFORMER IMPEDANCE
($s_k/100$)

	1	2	3	4	5	6	7	8	9	10	11	12	13	14	15
3	11	11	10	4	2	2	2
4	11	11	4	2	2	2
5	11	10	4	2	2
6	11	10	2	2	2
7	11	4	2	2
8	11	4	2	2
9	11	4	2
10	11	4	2
11	11	2	2
12	10	3
13	10	3
14	10	3	2	2
15	10	3	2	2
16	10	4	3	3	2	2

ACKNOWLEDGMENT

The work described in Sections IV and V was performed at Eindhoven University of Technology, Eindhoven, The Netherlands, in cooperation with Wim Kersten and Paul Dirix. The simulations presented in Sections II and III were done by Güllali Yalçinkaya at Manchester Center for Electrical Energy.

REFERENCES

- [1] L. Conrad, K. Little, C. Grigg, "Predicting and preventing problems associated with remote fault-clearing voltage dips," *IEEE Trans. Ind. Applicat.*, vol. 27, pp. 167-172, 1991.
- [2] Power System Reliability Subcommittee Voltage Sag Working Group (Chairman: L. E. Conrad), "Proposed chapter 9 for predicting voltage sags (dips) in revision to IEEE Std. 493, the Gold Book," *IEEE Trans. Ind. Applicat.*, vol. 30, pp. 805-821, May/June 1994.
- [3] M. H. J. Bollen, "Reliability analysis of industrial power systems taking into account voltage sags," in *IEEE Ind. Applicat. Soc. 28th Annu. Meeting*, Toronto, Canada, Oct. 2-7, 1993, pp. 1461-1468.
- [4] M. Z. El-Sadez, "Voltage instabilities subsequent to short-circuit recoveries," *Electric Power Syst. Res.*, vol. 21, pp. 9-16, 1991.
- [5] J. C. Das, "The effects of momentary voltage dips on the operation of induction and synchronous motors," *IEEE Trans. Ind. Applicat.*, vol. 26, pp. 711-718, 1990.
- [6] G. Yalçinkaya and M. H. J. Bollen, "Stochastic assessment of voltage sags for systems with large motor loads," presented at the Universities Power Engineering Conf., Galway, Ireland, Sept. 1994.
- [7] A. E. Efthymiadis, A. J. B. Heath, and R. D. Youssef, *IPSA User Manual, Version 9, Release 1.4*. Manchester, UK: University of Manchester Institute of Science and Technology, Sept. 1993.
- [8] M. H. J. Bollen, "A literature survey after reliability data of components in electric distribution systems," University of Technology, Faculty of Electrical Engineering, Eindhoven, The Netherlands, EUT-Rep. 93-E-276, 1993.



Math H. J. Bollen (M'94) received the M.Sc. and Ph.D. degrees from Eindhoven University of Technology, The Netherlands, in 1985 and 1989, respectively.

After three more years at the Eindhoven University of Technology, and three months at the University of The Netherlands Antilles, he became a lecturer at Manchester Centre for Electrical Energy, University of Manchester Institute of Science and Technology, UK. He previously did research in, among other areas, travelling-wave-based protection and power system reliability. Currently, he is involved in various aspects of power quality, with emphasis on the stochastic assessment of voltage sags.

Dr. Bollen is a member of the Power System Reliability subcommittee.