

TR/03/87

February 1987

The Influence of out-of-plane Stress on a
Plane Strain Problem in Rock Mechanics

by

M. B. Reed

(Her)
Of
1
676

z1624889

THE INFLUENCE OF OUT-OF-PLANE STRESS ON A
PLANE STRAIN PROBLEM IN ROCK MECHANICS

M. B. REED

Department of Mathematics and Statistics

Brunel University

Uxbridge, U.K.

Abstract

This paper analyses the stresses and displacements in a uniformly prestressed Mohr-Coulomb continuum, caused by the excavation of an infinitely long cylindrical cavity. It is shown that the solution to this axisymmetric problem passes through three stages as the pressure at the cavity wall is progressively reduced. In the first two stages it is possible to determine the stresses and displacements in the $r\theta$ -plane without consideration of the out-of plane stress σ_z . In the third stage it is shown that an inner plastic zone develops in which $\sigma_\theta = \sigma_z$, so that the stress states lie on a singularity of the plastic yield surface. Using the correct flow rule for this situation, an analytic solution for the radial displacements is obtained. Numerical examples are given to demonstrate that a proper consideration of this third stage can have a significant effect on the cavity wall displacements.

1. Introduction

Many situations in geotechnical engineering, such as dams, embankments and tunnels, can be treated as cases of plane strain; that is, there is no displacement in the out-of-plane or z-direction, and the shear stresses τ_{xz} and τ_{yz} are zero. If the soil or rock is elastic, then $\epsilon_z = 0$ and the stress and displacement analysis may be carried out purely in the xy-plane, with the out-of-plane stress found subsequently as $\sigma_z = \nu(\sigma_x + \sigma_y)$, ν , denoting the poisson's ratio.

Even if the material is elastic-plastic, it is often possible to ignore the influence of the out-of-plane stress. This is because the most commonly-used plastic yield criterion, that of Mohr-Coulomb, is expressed in terms of the major and minor principal stresses σ_1, σ_3 only, and σ_z can often be shown to be the intermediate principal stress at yield. However, this does not imply that σ_z remains intermediate throughout the deformation, and a complete analysis should evaluate σ_z throughout the yield zone to demonstrate the validity of this assumption.

One of the most important plane strain problems in rock mechanics is to predict the stresses and deformations induced in a pre-stressed rock continuum of infinite extent by the excavation of an infinitely long tunnel or cavity of uniform cross-section. An axisymmetric version of this situation, in which the tunnel has circular cross-section and the in situ stress field is of equal magnitude in all directions, is amenable to analytic solution, and it is this axisymmetric tunnel problem that will be considered in this paper.

Many rock mechanics texts (e.g. Jaeger & Cook 1979) feature the solution for the radial and tangential stresses σ_r, σ_θ in the rock mass when an elastic-brittle plastic material model is used with Mohr-Coulomb yield criterion, and with the assumption that $\sigma_r \leq \sigma_z \leq \sigma_\theta$ throughout. (Because of the axisymmetry, σ_r and σ_θ are the principal stresses in the xy-plane.) The zone of yielded rock forms an annulus around the tunnel, with a discontinuity in σ_θ at the

interface with the intact rock. The author (Reed 1986) has given an analytic solution for the displacement field assuming $\sigma_r < \sigma_z < \sigma_\theta$ with a dilation flow rule derived from the Mohr-Coulomb yield function. A lower limit on the tunnel support pressure p was also derived, for which the above assumption on σ_z remains valid. It is the purpose of this paper to analyse the problem when p drops below this limit.

In the following section the problem and notation are defined. The complete solution to the problem is then shown to pass through three stages as the tunnel support pressure is gradually reduced. The first stage is a standard result of elasticity theory. In the second, a plastic zone develops in which $\sigma_r < \sigma_z < \sigma_\theta$, and in the third an inner plastic zone forms in which $\sigma_r < \sigma_z < \sigma_\theta$. Stresses in this inner plastic zone lie on singular points of the Mohr-Coulomb yield surface. The effect of this on the displacement solution is considered in sections 5 and 6, and illustrated by graphs in section 7.

2. Statement of the problem

The axisymmetric tunnel problem may be described as follows:- consider a homogeneous isotropic rock mass, of infinite extent, with a uniform compressive in situ stress field of magnitude q in all directions. A long tunnel of circular cross-section, radius r_0 , is now excavated in the rock mass; the excavation process is represented by a gradual reduction in the normal support pressure p on the tunnel wall from $p = q$ to a final value $p = p_0$. The problem is one of plane strain, and because of the axisymmetry it may be analysed in the radial dimension. The unknowns are the stresses in the radial, tangential and out-of-plane directions ($\sigma_r \sigma_\theta \sigma_z$) which form the principal stress directions, and the inward radial displacement $u(r)$ at a radius r from the tunnel centre (see fig. 1).

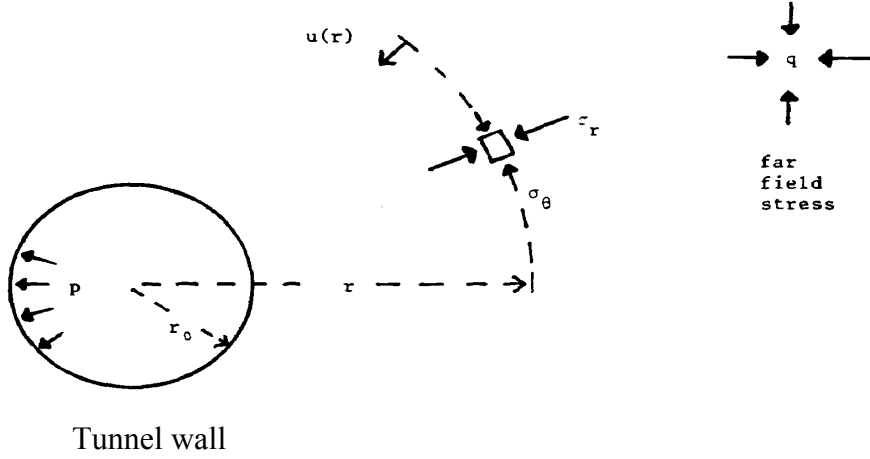

Fig. 1

The rock is taken as a linear elastic-brittle plastic Mohr-Coulomb material. That is, it deforms elastically until the yield criterion

$$\sigma_1 = k\sigma_3 + \sigma_c \quad (1)$$

is satisfied. Here, σ_1 and σ_3 are the major and minor principal stresses, k is the triaxial stress factor and σ_c the unconfined compressive strength. The last two parameters are related to the cohesion c and angle of internal friction ϕ by

$$k = \frac{1 + \sin \phi}{1 - \sin \phi}, \quad \sigma_c = \frac{2c \cos \phi}{1 - \sin \phi} \quad (2)$$

After yield, the stress state is constrained to lie on the residual yield surface $F(\underline{\sigma}) = 0$, where

$$F(\underline{\sigma}) = \sigma_1 - k^1 \sigma_3 - \sigma_c^1. \quad (3)$$

Note that $F(\underline{\sigma})$ is defined using the residual strength σ_c^1 which is strictly less than σ_c for a brittle rock, and residual triaxial stress parameter k^1 .

After initial yield, the process of stress reduction is described by a flow rule defined in terms of a plastic potential $Q(\underline{\sigma})$. If strains are split into elastic and plastic components, then the plastic strain increment is given by the flow rule

$$\underline{\dot{\epsilon}}^p = d\lambda \frac{\partial Q}{\partial \underline{\sigma}}, \quad (4)$$

where $d\lambda$ is a constant multiplier. The flow rule is termed associated if $Q = F$; we shall for generality consider a dilation flow rule defined by

$$Q(\varrho) = \sigma_1 - \ell\sigma_3 \quad (5)$$

where

$$\ell = \frac{1 + \sin \psi}{1 - \sin \psi}, \quad \text{with } \psi \text{ being an angle of dilation, } 0 \leq \psi \leq \phi .$$

Note that the stress state must everywhere satisfy the equilibrium equation

$$\sigma_\theta = r \frac{d\sigma_r}{dr} + \sigma_r \quad (6)$$

and that the boundary conditions are

$$\sigma_r = p \quad \text{at } r=r_0 \quad (7)$$

$$\text{and } \sigma_r, \sigma_\theta, \sigma_z \rightarrow q \quad \text{as } r \rightarrow \infty . \quad (8)$$

3. Solution: first stage

As the tunnel support pressure p is gradually reduced, the stress solution passes through three distinct stages. In the first stage, there is no plastic yield in the rock, and standard elasticity theory (Timoshenko & Goodier 1951) gives

$$\begin{aligned} \sigma_r &= q - (q - p) \left(\frac{r_0}{r} \right)^2 \\ \sigma_\theta &= q + (q - p) \left(\frac{r_0}{r} \right)^2 \\ \sigma_z &= q \end{aligned} \quad (9)$$

and radial displacement

$$u(r) = \frac{1 + \nu}{E} (q - p) r_0^2 / r. \quad (10)$$

This will continue until the stresses at the tunnel wall satisfy the yield criterion (1), that is, when

$$p = \bar{p} \equiv \frac{2q - \sigma_c}{k + 1}. \quad (11)$$

4. Solution: second stage

From this point on, an annular zone of failed rock will grow outwards around the tunnel. Let \bar{r} denote the radius of the interface between the plastic zone of failed rock and the surrounding mass of intact, elastic rock; the situation

is illustrated in fig. 2. At least initially, $\sigma_r < \sigma_z < \sigma_\theta$ at all points within the plastic zone.

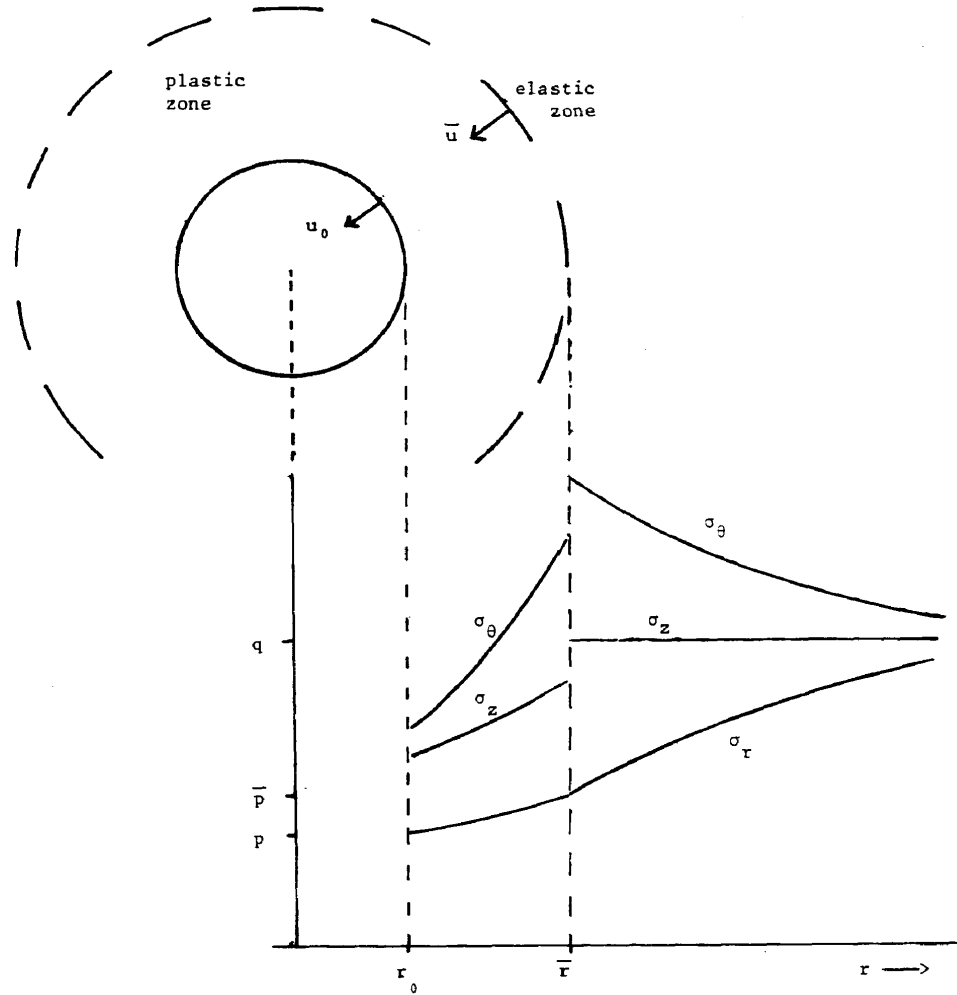

Fig. 2

The stress solution may be found (Fenner 1938) as:

In the elastic zone $r > \bar{r}$:

$$\begin{aligned}\sigma_r &= q - (q - \bar{p})\left(\frac{\bar{r}}{r}\right)^2 \\ \sigma_\theta &= q + (q - \bar{p})\left(\frac{\bar{r}}{r}\right)^2 \\ \sigma_z &= q,\end{aligned}\tag{12}$$

Where \bar{p} is defined in (11), and is the value of σ_r at the interface.

In the plastic zone $r_0 \leq r < \bar{r}$:

$$\begin{aligned}\sigma_r &= (p+p')\left(\frac{r}{r_0}\right)^{k'-1} - p' \\ \sigma_\theta &= k'(p+p')\left(\frac{r}{r_0}\right)^{k'-1} - p' \\ \sigma_z &= v(\sigma_r + \sigma_\theta)(1-2\nu)q\end{aligned}\quad (13)$$

where $p' = \frac{\sigma'_c}{k'-1}$.

As the radial stress must be continuous at the interface, the radius \bar{r} is obtained as

$$\bar{r} = r_0 \left[\frac{\bar{p} + p'}{p + p'} \right]^{\frac{1}{k'-1}}. \quad (14)$$

As mentioned previously, strains may be decomposed into elastic and (in the plastic zone) plastic components:

$$\underline{\varepsilon} = \underline{\varepsilon}^e + \underline{\varepsilon}^p. \quad (15)$$

Elastic strains are related to stresses by

$$\begin{aligned}\varepsilon_r^e &= \frac{1}{E}[\sigma_r - \nu\sigma_\theta - \nu\sigma_z - (1-2\nu)q] \\ \varepsilon_\theta^e &= \frac{1}{E}[\sigma_\theta - \nu\sigma_r - \nu\sigma_z - (1-2\nu)q] \\ \varepsilon_z^e &= \frac{1}{E}[\sigma_z - \nu\sigma_r - \nu\sigma_\theta - (1-2\nu)q]\end{aligned}\quad (16)$$

and at equilibrium

$$\varepsilon_r = \frac{du}{dr} \text{ and } \varepsilon_\theta = \frac{u}{r}. \quad (17)$$

The radial displacement $u(r)$ in the elastic zone is thus (since $\varepsilon_z = 0$)

$$u(r) = \frac{1+\nu}{E} r(q-\bar{p})\left(\frac{\bar{r}}{r}\right)^2. \quad (18)$$

To find the displacements in the plastic zone the flow rule (4) is needed. Since $\sigma_\theta \equiv \sigma_1$ and $\sigma_r \equiv \sigma_3$, inserting (5) in (4) and eliminating $d\lambda$ yields

$$\dot{\varepsilon}_r^p + \ell \dot{\varepsilon}_\theta^p = 0 \text{ and } \dot{\varepsilon}_z^p = 0 \quad (19)$$

and by summing the increments

$$\varepsilon_r^p + \ell \varepsilon_\theta^p = 0 \text{ and } \varepsilon_z^p = 0 \quad (20)$$

Combining (13), (15), (16), (17), (20) gives a differential equation for u :

$$\frac{du}{dr} + \ell \frac{u}{r} = \frac{1+\nu}{E} \left[A \left(\frac{r}{\sqrt{r}} \right)^{k'-1} + B \right] \quad (21)$$

Where

$$A = [(1+k'\ell)(1-\nu) - (k'+\ell)\nu](\bar{p} + p'), B = -(1-2\nu)(\ell+1)(q+p').$$

The solution, using the continuity of u at $r = \bar{r}$ from (18), is

$$u(r) = \frac{1+\nu}{E} r \left[k_2 \left(\frac{r}{\sqrt{r}} \right)^{k'-1} + k_2 \left(\frac{\bar{r}}{r} \right)^{\ell+1} + k_3 \right] \quad (22)$$

where

$$k_1 = \frac{1}{k'+\ell} A, \quad k_3 = \frac{1}{\ell+1} B$$

and

$$k_2 = q - \bar{p} - k_1 - k_3.$$

5. Solution: third stage

The author (Reed 1986) has shown that the second stage will continue until the tunnel support pressure p reaches the value P where

$$p = \frac{1-2\nu}{k'-k'\nu-\nu} (q+p') - p'. \quad (23)$$

At this point $\sigma_\theta = \sigma_z$ at the tunnel wall. If p drops further, an inner plastic zone develops in which $\sigma_r < \sigma_\theta \leq \sigma_z$. Let R denote the outer radius of this inner plastic zone. To analyse this situation, we will consider the two cases (i) $\sigma_\theta = \sigma_z$ and (ii) $\sigma_\theta < \sigma_z$ in this zone separately, and show that (ii) is impossible. The resultant situation is shown in fig. 3.

5.1 $\sigma_r < \sigma_\theta = \sigma_z$ in inner plastic zone.

In this case the stress solution for a and a . in the inner zone is still given by (13), since the relation $\sigma_\theta = k'\sigma_r + \sigma'_c$ still holds there. The interface radius \bar{r} is also still given by (14), and σ_z is given by (13) in the outer, and $\sigma_z = \sigma_\theta$ in the inner zone. By equating σ_z and σ_θ from (13), the boundary between the inner and outer plastic zones is at

$$R = r_0 \left[\frac{p+p'}{p+p'} \right]^{\frac{1}{k'-2}} \quad (24)$$

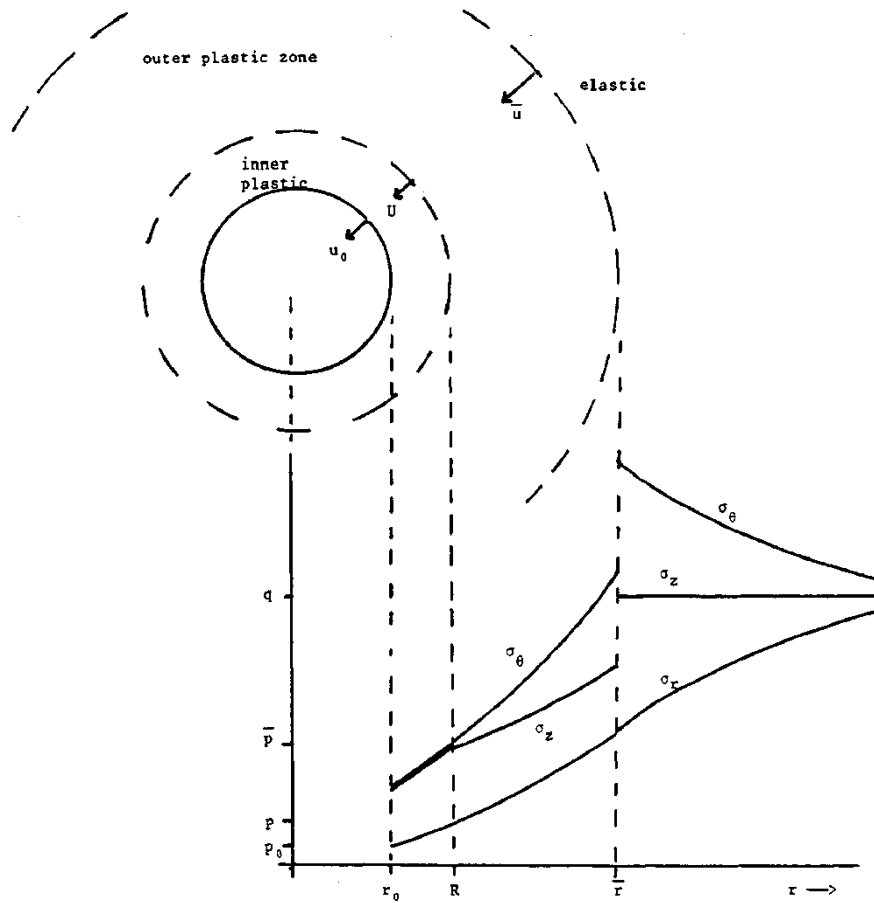

Fig. 3

The analysis of the previous section for the radial displacement $u(r)$ also still holds in the outer plastic zone. The displacements in the inner plastic zone will now be derived.

In the inner zone $r_0 < r < R$ the stress states lie on the intersection of the two yield surfaces $\sigma_\theta = k'\sigma_r + \sigma_c'$ and $\sigma_z = k'\sigma_r + \sigma_c'$, that is on one of the singularities of the yield surface generated by the Mohr-Coulomb condition in three-dimensional principal stress space. In these circumstances, Koiter (1953) showed that the correct flow rule is obtained by summing the contributions from the two plastic potentials

$$\begin{aligned} Q_1(\bar{\sigma}) &= \sigma_\theta - \ell \sigma_r \\ Q_2(\bar{\sigma}) &= \sigma_z - \ell \sigma_r \end{aligned} \quad (25)$$

to give

$$\dot{\bar{\epsilon}}^p = d\lambda_1 \frac{\partial Q_1}{\partial \bar{\sigma}} + d\lambda_2 \frac{\partial Q_2}{\partial \bar{\sigma}} \quad (26)$$

Eliminating $d\lambda_1$ and $d\lambda_2$ from the resulting three equations, gives

$$\dot{\epsilon}_r^p + \ell \dot{\epsilon}_\theta^p + \ell \dot{\epsilon}_z^p = 0. \quad (27)$$

While the rock was in the outer plastic zone at earlier stages of the deformation, the plastic strains satisfied (20), so that (27) may be integrated to give

$$\epsilon_r^p + \ell \epsilon_\theta^p + \epsilon_z^p = 0. \quad (28)$$

Using (13), (15), (16), (17) and with $\sigma_z = \sigma_\theta$ and $\epsilon_z = 0$, the differential equation for the displacements in the inner plastic zone is

$$\frac{du}{dr} + \ell \frac{u}{r} = \frac{1}{E} \left[c \left(\frac{r}{f} \right)^{k'-1} + D \right] \quad (29)$$

where

$$\begin{aligned} C &= [1 + 2k'\ell - 2(k' + \ell + k'\ell)v](\bar{p} + p') \\ D &= (2\ell + 1)(1 - 2v)(q + p'). \end{aligned}$$

The solution for $u(r)$ is

$$u(r) = \frac{1}{E} r \left[L_1 \left(\frac{r}{\bar{r}} \right)^{k'-1} + L_2 \left(\frac{\bar{r}}{r} \right)^{\ell+1} + L_3 \right] \quad (30)$$

where

$L_1 = \frac{1}{k' + \ell} C$ and $L_3 = \frac{1}{\ell + 1} D$. The coefficient L_2 is found from the continuity of u at $r = R$, using (22).

A more complicated, coupled analysis for stresses and displacements is necessary with assumption (ii). It will finally be shown, however, that the resulting solution is inconsistent,

5.2 $\sigma_r < \sigma_\theta < \sigma_z$ in inner plastic zone

In this case, the stresses in the elastic zone $r > \bar{r}$ are still given by (12); in the outer plastic zone $R < r < \bar{r}$ the equilibrium equation (6), yield surface (3) and continuity of σ_r give

$$\begin{aligned}\sigma_r &= (\bar{p} + p')(\sqrt[r]{r})^{k'-1} - p' \\ \sigma_\theta &= k(\bar{p} + p')(\sqrt[r]{r})^{k'-1} - p' \\ \sigma_z &= \nu(\sigma_r + \sigma_\theta) + (1 - 2\nu)q\end{aligned}\quad (31)$$

although \bar{r} is as yet undetermined. By equating σ_z and σ_θ at $r = R$, R is related to \bar{r} by

$$R = \alpha k'^{-1} \bar{r} \quad (32)$$

where $\alpha = \frac{(1 - 2\nu)(q + p')}{(k' - \nu - k'\nu)(\bar{p} + p')}$. The displacements in the outer plastic zone are still given in terms of \bar{r} by (22).

From (16), (31), (32), with $\varepsilon_x^e = 0$, the elastic strains at $r = R$ can be determined, and it is found that $\varepsilon_\theta^e = 0$ on the outer-zone side of this boundary. The plastic tangential strain is thus equal to the total tangential strain, which using (17) and (22) gives

$$\tilde{\varepsilon}_\theta^p \equiv \varepsilon_\theta(R) = \frac{1 + \nu}{E} \left[k_1 \alpha + k_2 \alpha \frac{-(\ell + 1)}{k - 1} + k_3 \right]. \quad (33)$$

In the inner plastic zone, the failure surface

$$\sigma_z = k\sigma_r + \sigma_c \quad (34)$$

gives rise to a flow rule which produces the relations

$$\dot{\varepsilon}_r^p + \ell \dot{\varepsilon}_z^p = 0, \dot{\varepsilon}_\theta^p = 0 \quad (35)$$

As $\tilde{\varepsilon}_\theta^p$ in (33) is independent of the tunnel support pressure p and the boundary radius R , it follows that this was the plastic tangential strain at each rock element when it passed into the inner plastic zone during the excavation process. By (20) the other plastic strains at this point are

$$\tilde{\varepsilon}_r^p = -\ell \tilde{\varepsilon}_z^p \text{ and } \tilde{\varepsilon}_z^p = 0. \quad (3.6)$$

Summing the plastic strain increments once in the inner plastic zone, from (35),

$$\varepsilon_r^p + \ell \varepsilon_z^p = \tilde{\varepsilon}_z^p + \tilde{\varepsilon}_\theta^p = \tilde{\varepsilon}_z^p \text{ and } \varepsilon_\theta^p = \tilde{\varepsilon}_\theta^p. \quad (37)$$

By (15) and the plane strain condition,

$$\varepsilon_r = \varepsilon_r^e + \ell \varepsilon_z^e - \ell \tilde{\varepsilon}_\theta^p \text{ and } \varepsilon_\theta = \varepsilon_\theta^e + \tilde{\varepsilon}_\theta^p. \quad (38)$$

Combining (6), (15), (16), (34), (38),

$$\frac{du}{dr} = \frac{1}{E} \{ [1 - \nu - k'\nu + \ell(k' - 2\nu)]\sigma_r - (\ell + 1)\nu r \frac{d\sigma_r}{dr} + (\ell - \nu)\sigma_c' - (\ell + 1)(1 - 2\nu)q \} - \ell \tilde{\epsilon}_\theta^p \quad (39)$$

and

$$u = \frac{1}{E} r \{ [1 - \nu - k'\nu]\sigma_r + r \frac{d\sigma_r}{dr} - \nu\sigma_c' - (1 - 2\nu)q \} + r \tilde{\epsilon}_\theta^p \quad (40)$$

Differentiating (40) and equating with (39) produces a second-order differential equation in σ_r , with general solution

$$\sigma_r = F(r/R)^{n_1} + G(r/R)^{n_2} + H \quad (41)$$

where n_1, n_2 are the roots of

$$n^2 + (2 - k'\nu + \ell\nu)n - \ell(k' - 2\nu) = 0 \quad (42)$$

and

$$H = \frac{-1}{k' - 2\nu} \left[\sigma_c' - (1 - 2\nu)q - \frac{\ell + 1}{\ell} E \tilde{\epsilon}_\theta^p \right] \quad (43)$$

F and G are determined from the boundary conditions at $r = R$, namely continuity with the outer zone stresses (31):

$$\begin{aligned} F &= \frac{1}{n_1 - n_2} [(k' - 1 - n_2)\alpha(\tilde{p} + p') + n_2 p' + n_2 H] \\ G &= \frac{-1}{n_1 - n_2} [(k' - 1 - n_1)\alpha(\bar{p} + p') + n_1 p' + n_1 H] \end{aligned} \quad (44)$$

and R (and hence \bar{r} by (32)) is expressed in terms of the tunnel support pressure p by setting $\sigma_r = p$ at $r = r_0$. Finally, by substituting into (40) the displacements $u(r)$ are found. Note however that the nonlinear equation defining R cannot be solved explicitly, and a numerical method such as Newton-Raphson must be used.

When this analysis is applied to specific problems, and the resulting stresses evaluated at points within the inner plastic zone (e.g. at the tunnel wall), it is found that they violate the original assumption that $\sigma_z > \sigma_\theta$. It will now be shown that this is the case in general. This is done by proving that

$$\frac{d\sigma_z}{dr} > \frac{d\sigma_\theta}{dr} \quad \text{at } r = R.$$

Using (6), (34) and (41), at $r = R$

$$\frac{d\sigma_z}{dr} = \frac{1}{R}(n_1 k' F + n_2 k' G)$$

and

$$\frac{d\sigma_\theta}{dr} = \frac{1}{R}[n_1(1+n_1)F + n_2(1+n_2)G]. \quad (45)$$

So using (44)

$$R \left(\frac{d\sigma_z}{dr} - \frac{d\sigma_\theta}{dr} \right) = (k'-1-n_1)(k'-1-n_2)\alpha(\bar{p}+p') - n_1 n_2 (p'+H). \quad (46)$$

By (42),

$$n_1 + n_2 = -2(k'-\ell)v \quad \text{and} \quad n_1 n_2 = -\ell(k'-2v)$$

so that by expanding (46) and using (32) and (43),

$$\frac{d\sigma_z}{dr} - \frac{d\sigma_\theta}{dr} = \frac{1}{R} \left[\frac{(k'-1)(k'-2k'v+1+\ell v)(1-2v)(q+p')}{k'-k'v-v} + (\ell+1)E \tilde{\epsilon}_\theta^p \right] \quad (47)$$

at $r = R$.

But the right-hand-side of (47) is the sum of two positive terms, if $k' > 1$, $\ell > 1$ and $0 \leq v \leq \frac{1}{2}$, so

$$\frac{d\sigma_z}{dr} > \frac{d\sigma_\theta}{dr} \quad \text{at } r = R.$$

Since $\sigma_z = \sigma_\theta$ at this point, and the derivatives are both positive at $r = R$ since σ_r is monotone increasing, it follows that there is a region on the inner-zone side of $r = R$ in which $\sigma_\theta > \sigma_z$.

The assumption $\sigma_r < \sigma_\theta < \sigma_z$ thus leads to a solution which is inconsistent, and the conclusion is $\sigma_r < \sigma_\theta = \sigma_z$ that in the inner plastic zone.

6. Problems with large drop in strength

From (14) and (24) it is seen that the ratio R/\bar{r} is independent of the tunnel support pressure p , so that once the inner zone is formed the inter-zone boundaries at \bar{r} and R will move out together. The outer plastic zone will only exist if $\bar{r} < R$, and this holds if $P < \bar{p}$; substituting the definitions in (11) and (23) leads to

$$\sigma_c - \sigma_c' < \frac{1}{1-v}(q - \bar{p}) - (k - k')\bar{p}. \quad (48)$$

Thus, if the drop in strength upon yield is sufficiently large, this condition may not be satisfied. In this case the whole plastic zone will have $\sigma_z = \sigma_\theta$; the other stresses are given by (13), the interface radius by (14), the displacements are given by (30) but with the coefficient L_2 determined from the continuity of u at \bar{r} using (10).

7. Numerical results

For problems involving only a small relative drop in strength upon yield, the influence of the out-of-plane stress upon the wall displacement will be minor. For example, consider the data:

$$q = 30, \quad \sigma_c = 40, \quad \sigma_c' = 20; \quad \nu = 0.1, \quad k = k' = \ell = 3.$$

For this problem yield will first occur when p drops to $\bar{p} = 5$. The inner plastic zone will arise when p drops to $P = 2.308$, In Fig.4 a graph is plotted of relative wall displacement Eu_0/r_0 against pressure difference $q-p$, as p drops from 10 (when the rock is still elastic) to zero. The relative displacement ignoring the effect of the out-of-plane stress (that is, using (22) throughout) is also plotted in broken line, for comparison. When $p = 0$, the relative displacement is 70.269 using (30), compared with 69.300 using (22).

When the relative drop in strength is greater, the difference between the true solution (30) and the two-dimensional solution (22) is more significant. For the data:

$$q = 100, \quad \sigma_c = 150, \quad \sigma_c' = 50, \quad \nu = 0.1, \quad k = k' = \ell = 5$$

the outer plastic zone starts when $p = \bar{p} - 8.333$, and the inner plastic zone when $p = P = 7.955$. The relative wall displacements at $p = 0$ are 264.78 using (30), compared with 251.32 using (22). The corresponding graph is shown in Fig.5.

If the residual strength in the previous example is now reduced to 20, then inequality (48) is no longer satisfied and the whole plastic zone has $\sigma_z = \sigma_\theta$. Now the relative wall displacements at $p = 0$ are 722.24 using (30), and 618.32 using (22). The graph is given in Fig.6.

8. Conclusions

This paper has presented a complete analysis for the stresses and displacements in the axisymmetric tunnel problem using a Mohr-Coulomb yield surface. The deformation is shown to occur in three stages, in the last of which the out-of-plane stress influences the displacements in an inner plastic zone. For materials with a large drop in strength at yield, or with a low Poisson's ratio, the tunnel wall displacements can be significantly greater than those predicted by an analysis which ignores this influence.

For more complex (and more realistic) situations involving material anisotropy or non-circular tunnel profile, a numerical model is commonly produced by the finite element method. In this case the singularities of the yield surface, at which the flow vector would be indeterminate, are removed by 'rounding off the corners'. Given the tendency of stress states in the plastic region to approach these corners, it is essential to evaluate the out-of-plane stress and plastic strain throughout the deformation when using the flow rule (4), if the numerical solution is to converge to the correct displacement field.

9. Acknowledgements

The author is grateful to the Science and Engineering Research Council, and British Coal for sponsoring a research project in which this work was performed.

10. References

FENNER, R. 1938 Untersuchungen zur Erkenntnis des Gebirgsdrucks.
Diss. T. U. Breslau.

JAEGER, J.C. and COOK, N.G.W. 1979 Fundamentals of Rock Mechanics, 3rd ed.
London: Chapman & Hall.

KOITER, W.T. 1953 Stress-strain relations, uniqueness and variational theorems for elastic-plastic materials with singular yield surface.
Quart. Appl. Math., 11, 350-354.

REED, M.B. 1986 Stresses and displacements around a cylindrical cavity in soft rock. I.M.A. J. Appl. Math., 36, 223-245.

TIMOSHENKO, S.P. and GOODIER, J.N. 1951 Theory of Elasticity New York:
McGraw-Hill

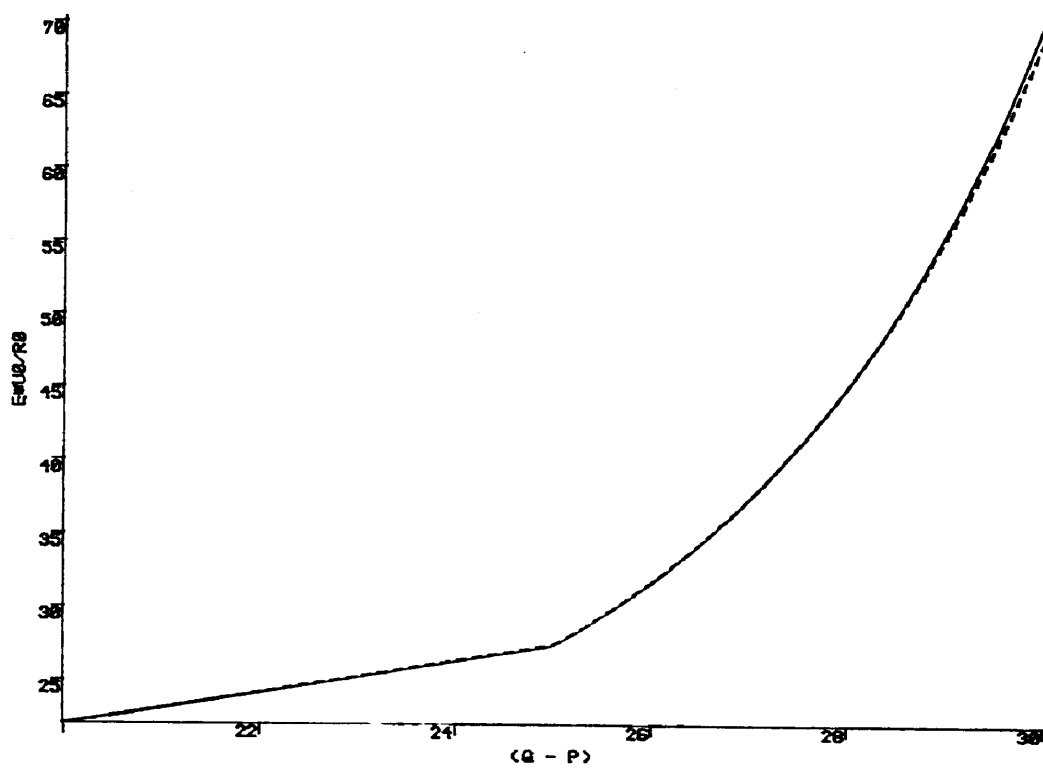

Fig:4

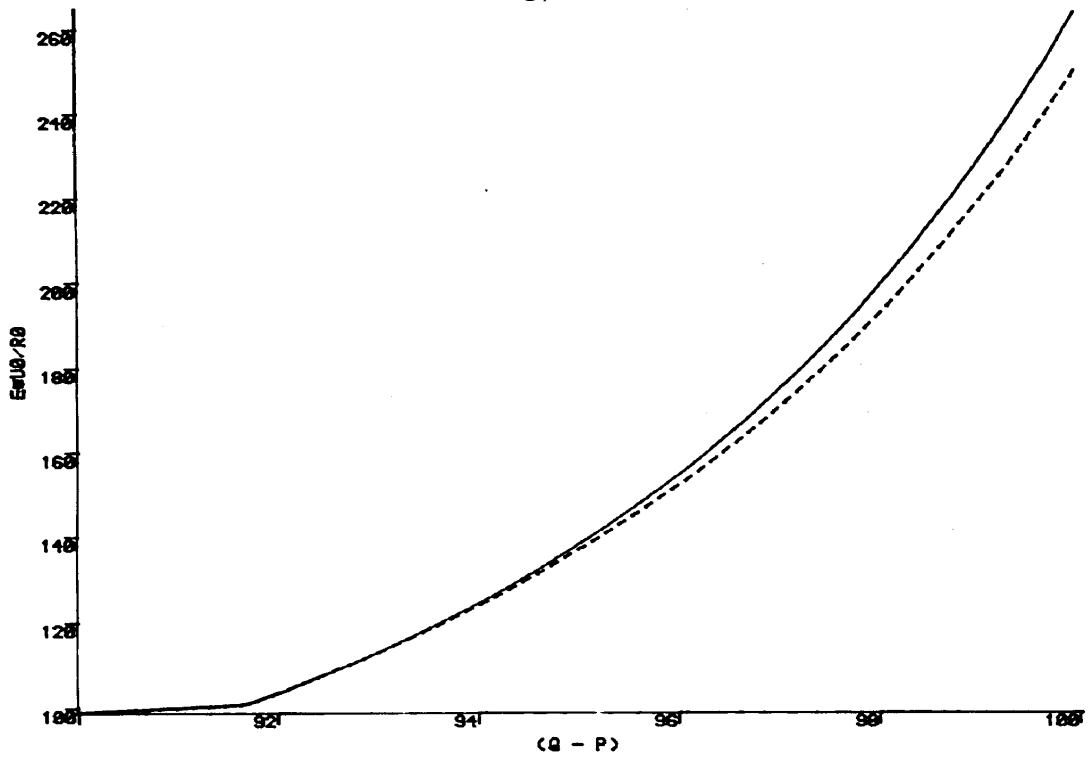

Fig. 5

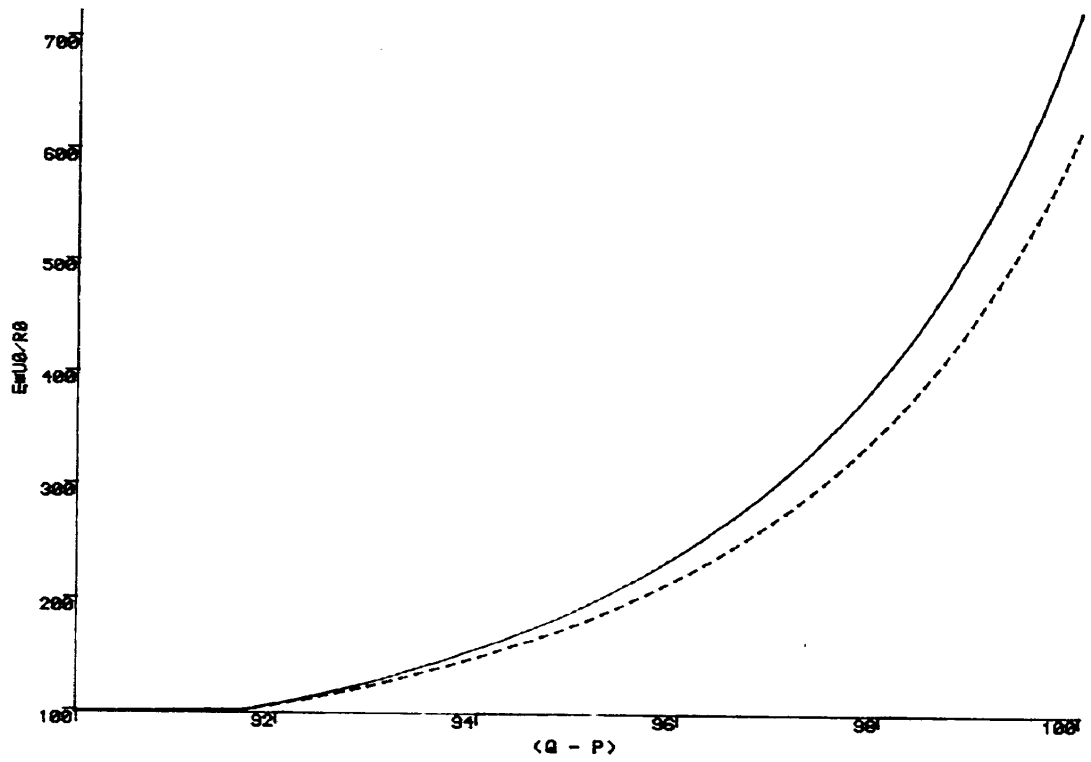

Fig 6

**NOT TO BE
REMOVED
FROM THE LIBRARY**

