

The link between product data model and process model : the effect of changes in the product data model on the process model

Citation for published version (APA):

Vogelaar, J. J. C. L., & Reijers, H. A. (2009). *The link between product data model and process model : the effect of changes in the product data model on the process model*. (BETA publicatie : working papers; Vol. 281). Technische Universiteit Eindhoven.

Document status and date:

Published: 01/01/2009

Document Version:

Publisher's PDF, also known as Version of Record (includes final page, issue and volume numbers)

Please check the document version of this publication:

- A submitted manuscript is the version of the article upon submission and before peer-review. There can be important differences between the submitted version and the official published version of record. People interested in the research are advised to contact the author for the final version of the publication, or visit the DOI to the publisher's website.
- The final author version and the galley proof are versions of the publication after peer review.
- The final published version features the final layout of the paper including the volume, issue and page numbers.

[Link to publication](#)

General rights

Copyright and moral rights for the publications made accessible in the public portal are retained by the authors and/or other copyright owners and it is a condition of accessing publications that users recognise and abide by the legal requirements associated with these rights.

- Users may download and print one copy of any publication from the public portal for the purpose of private study or research.
- You may not further distribute the material or use it for any profit-making activity or commercial gain
- You may freely distribute the URL identifying the publication in the public portal.

If the publication is distributed under the terms of Article 25fa of the Dutch Copyright Act, indicated by the "Taverne" license above, please follow below link for the End User Agreement:

www.tue.nl/taverne

Take down policy

If you believe that this document breaches copyright please contact us at:

openaccess@tue.nl

providing details and we will investigate your claim.

The link between product data model and process model

The effect of changes in the product data model on the process model

Beta Rapport

july 22nd, 2009

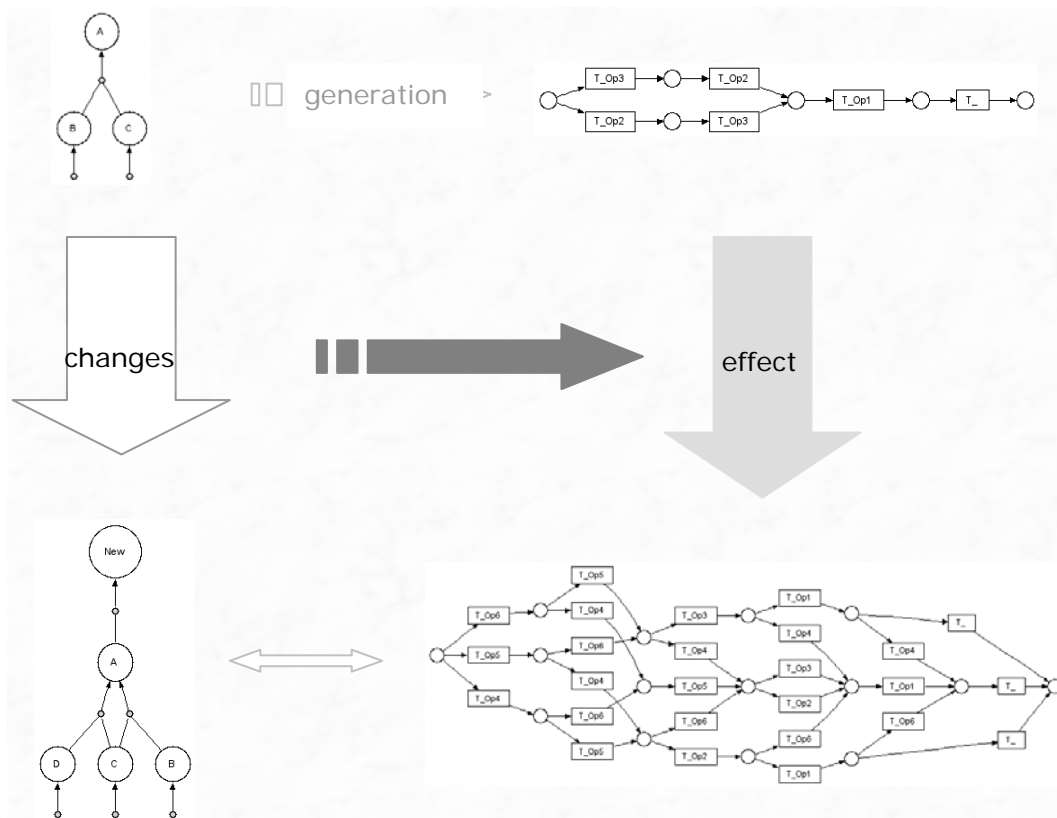

Jan Vogelaar, Hajo A. Reijers
Eindhoven University of Technology
P.O. Box 513, 5600 MB Eindhoven
The Netherlands

Abstract

Following the 'product based design' approach, a process model can be generated directly from the product data model, i.e. a specification of the end product. Such end products, however, can be subject to change, and generating a new process model for every small change, can become a burden.

Changes to the product data model affect the corresponding process model. In this paper these effects are investigated, to be able to alter the process model, based on changes in the product data model, without the need to regenerate the process model from scratch.

Table of contents

Table of contents	3
1. Introduction	4
1.1. Definitions.....	4
2. Changes to the product data model	6
2.1. Algorithm Alpha	6
2.1.1. Alpha : Deletion of an operation	6
2.1.2. Alpha : Addition of an operation	8
2.1.3. Alpha : Deletion of a data element.....	9
2.1.4. Alpha : Addition of a data element.....	10
2.1.5. Summary of basic change primitives with algorithm Alpha.....	11
2.2. Algorithm Bravo	12
2.2.1. Bravo : Deletion of an operation.....	12
2.2.2. Bravo : Addition of an operation	13
2.2.3. Bravo : Deletion of a data element	14
2.2.4. Bravo : Addition of a data element.....	15
2.2.5. Summary of basic change primitives with algorithm Bravo	17
2.3. Algorithm Charlie	18
2.3.1. Charlie : Deletion of an operation	18
2.3.2. Charlie : Addition of an operation	19
2.3.3. Charlie : Deletion of a data element	20
2.3.4. Charlie : Addition of a data element	21
2.3.5. Summary of basic change primitives with algorithm Charlie.....	22
2.4. Algorithm Delta.....	23
2.4.1. Delta : Deletion of an operation.....	23
2.4.2. Delta : Addition of an operation.....	25
2.4.3. Delta : Deletion of a data element	27
2.4.4. Delta : Addition of a data element	29
2.4.5. Summary of basic change primitives with algorithm Delta	32
2.5. Algorithm Echo	33
2.5.1. Echo : Deletion of an operation	33
2.5.2. Echo : Addition of an operation	34
2.5.3. Echo : Deletion of a data element	36
2.5.4. Echo : Addition of a data element	37
2.5.5. Summary of basic change primitives with algorithm Echo.....	38
2.6. Algorithm Foxtrot	39
2.6.1. Foxtrot : Deletion of an operation	39
2.6.2. Foxtrot : Addition of an operation	40
2.6.3. Foxtrot : Deletion of a data element.....	41
2.6.4. Foxtrot : Addition of a data element.....	43
2.6.5. Summary of basic change primitives with algorithm Foxtrot	45
2.7. Algorithm Golf	46
2.7.1. Golf : Deletion of an operation	46
2.7.2. Golf : Addition of an operation	47
2.7.3. Golf : Deletion of a data element	48
2.7.4. Golf : Addition of a data element	50
2.7.5. Summary of basic change primitives with algorithm Golf.....	51
References	52

1. Introduction

Product based design (PBD) is a revolutionary approach to business process redesign [3]. The process design is derived from the characteristics of the end product and in this way optimally tuned to delivering the end product. The method holds quite some promise. It distinguishes itself from other redesign methods, which usually focus on the tweaking an existing process.

PBD can be quite time consuming in terms of studying the product specification and determining the product data model. Still, determining the product data model is a useful exercise in most cases as it makes the specification of the end product explicit, for all parties involved, which can lead to new insights.

When the product data model is defined, the process model can be automatically generated, using one of several implemented algorithms [2, 4]. Depending on the size and characteristics of the product data model, and depending on the chosen algorithm, this generation can be quick, or take some time.

The end product can be subject to change. It can be a burden to keep regenerating the process model, for every small change in the product data model. This particularly holds when an existing process model is already embedded within an organization, for example when it has been linked to the IT and physical infrastructure. As the derivation of a process model from a product data model is formalized, changes to the product data model have a predictable effect on the corresponding process model, depending on the utilized algorithm. In this paper, these effects are investigated, to enable process modelers to alter the process model, according to small changes in the product data model.

With this knowledge it is also possible to explain to different parties, what certain changes to the product specification, might have on the process.

Four change primitives are identified as the possible elemental changes to a product data model. These 4 change primitives are discussed for each of the seven existing generation algorithms. In Section 2, each algorithm is discussed in this way, concluded with a small summary on how the changes to the product data model can be carried over to the process model.

1.1. Definitions

Change primitive	One of four possible identified elemental changes to a (product data) model. In this document these changes are the addition and deletion of a data element and the addition and deletion of an operation.
Dangling sections (places or transitions in a process model)	Places or transitions (not being start or end place) either without incoming or

	without outgoing arcs. Either unreachable sections of the process model, or dead ends.
--	--

2. Changes to the product data model

The relation between changes to the product data model and the resulting changes in the corresponding process model are the subject of this research report. In the following sections the now available algorithms for PDM-conversion are investigated through the use of test cases. Most of the test cases have been defined in the graduation report of Johfra Kamphuis [1]. In this section all algorithms will be exposed to these test cases to cover all changes in the product data model, and investigate what the effect is on the corresponding process model.

There are 4 different basic change primitives to the product data model to be investigated. These are the addition or deletion of an operation and the addition or deletion of a data element as described in [1]. By investigating these 4 instances, all alterations to a product data model are covered. For example, moving a data element in the model from one place to the other within the model, can be established by deleting the element and subsequently adding it at the desired location.

With each case, the effect through the algorithm is shortly discussed. For a more elaborate description of the workings of the different algorithms, see [2].

2.1. Algorithm Alpha

Algorithm Alpha works top-down and gradually expands the model from the root element. Here a difference is made between cases where there are different operations that can produce a particular data element and cases where only one operation can lead to that element. In the first situation an output place is created for the two possible operations as output place, as can be seen in the process model in Figure 2.1.1 (*place X*). *produce_B* and *produce_C* are examples of operations that produce an output element, that only can be produced by them.

The algorithm creates a transition for each data element (possibly in multiple locations in the process model).

In Figure 2.1.1. an example product data model is presented, accompanied by its corresponding process model. The data elements are numbered and these numbers are placed by the corresponding transitions in the process model, to indicate the relation between the two models. As there are two ways to reach the root element *A*, both of which include data element *C*, its corresponding transition occurs twice in the process model, indicated with numbers *3a* and *3b*.

2.1.1. Alpha : Deletion of an operation

The first change that will be discussed, is the deletion of an operation. In Figure 2.1.1 the data elements are numbered, but also one operation, numbered 4. This operation is removed and the resulting product data model is depicted in Figure 2.1.2.

The corresponding process models are depicted with their product data models. The changes that need to be made to the process model, based on the change in the product model, are discussed in this section.

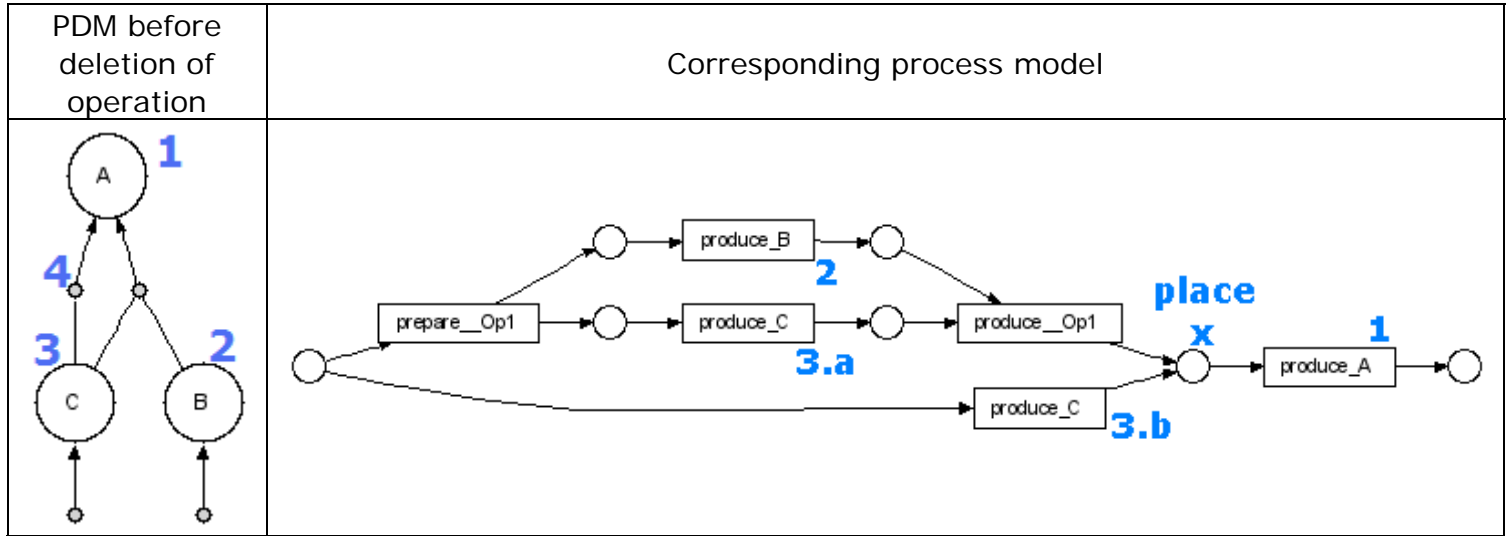

Figure 2.1.1 – PDM and process model before deletion of operation (Alpha)

Every operation in the product data model is represented by a transition in the corresponding process model. When an operation is removed from a product data model, the corresponding transition is removed from the process model. The operation producing a data element, is represented by a transition, named *produce_B* in the case of producing data element *B*. If there are two alternative ways of producing a data element (like *A* in Figure 2.1.1) and one of these alternatives is an operation using multiple input elements, then that operation is represented by a transition named *produce_Op'x'*. An example of this can be found in Figure 2.1.1 as *produce_Op1*.

As operation 4 is deleted in the product data model in Figure 2.1.2, the corresponding branch with transition 3.b is no longer possible. This means the prepare and produce transitions for Op1 will no longer be needed, as the prepare and produce transitions for *A* will be present as well, and with no further choice in operations, the *prepare_Op1* and *produce_Op1* transitions will be unnecessary.

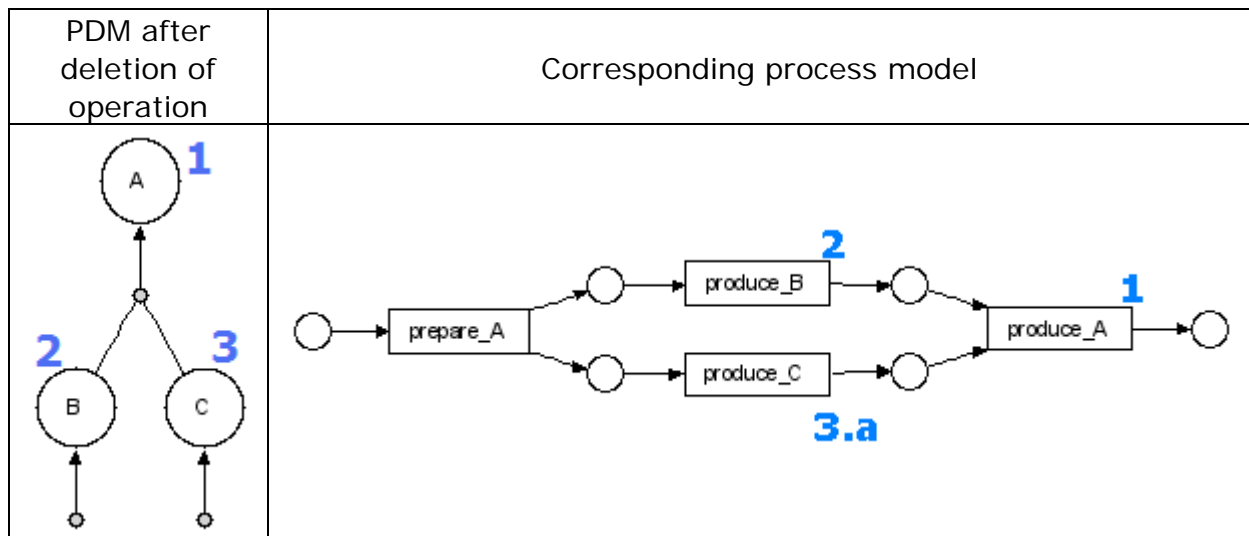

Figure 2.1.2 - PDM and process model after deletion of operation (Alpha)

Another change that appears to have taken place is the renaming of the first transition in the process model. This is not true however, since *prepare_Op1* is not created in the second case, as described above, but *prepare_A* is. The latter is also created in the first model, but the algorithm simplifies the model, by removing “unnecessary” transitions, as described above, and *prepare_A* is such a superfluous transition.

2.1.2. Alpha : Addition of an operation

In this section the addition of an operation is discussed. As shown in Figure 2.1.3 and Figure 2.1.4 an extra operation is added, to create data element A, by using only data element C. This operation is numbered 4 in Figure 2.1.4.

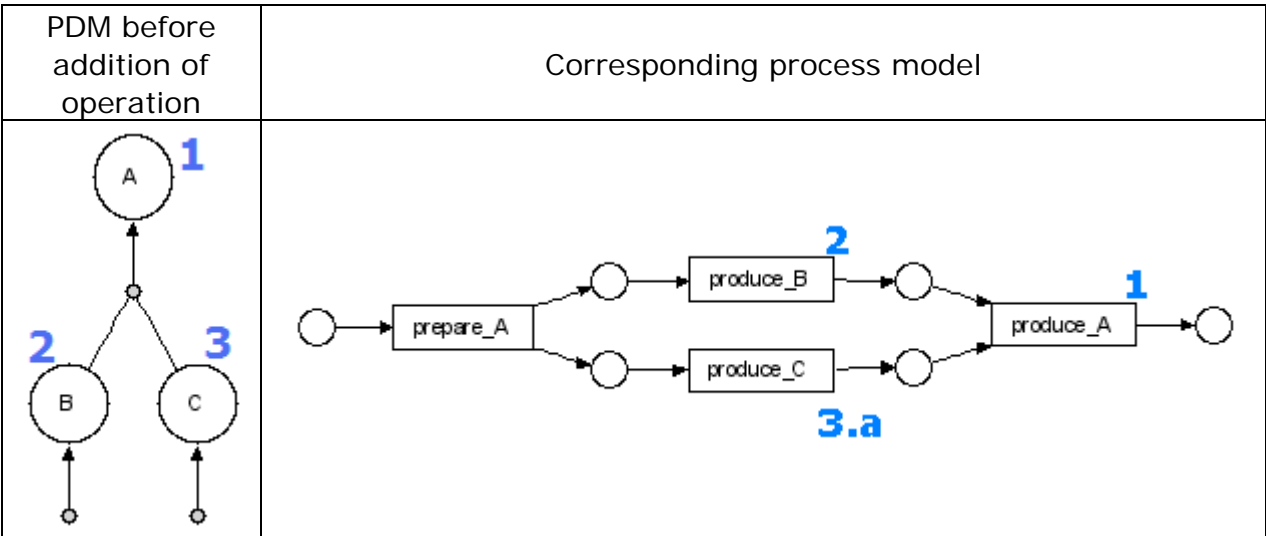

Figure 2.1.3 - PDM and process model before addition of operation (Alpha)

As all operations in the product data model are represented by transitions in the corresponding process model, adding an operation to the product data model, results in adding a transition to the process model. In this case, transition 3.b is added, which represents the creation of data element C to be used in the new operation (where data element A can be produced, solely based on data element C).

This new transition forms an alternative path to the already existing path. Because the existing path has two branches that are traversed in parallel, at the start and end of this branch *prepare_Op1* and *produce_Op1* are added respectively to get a single starting and ending transition for the branch. Furthermore, the *prepare_A* transition is removed, since it precedes the now new *prepare_Op1*, resulting in the process model depicted in Figure 2.1.4.

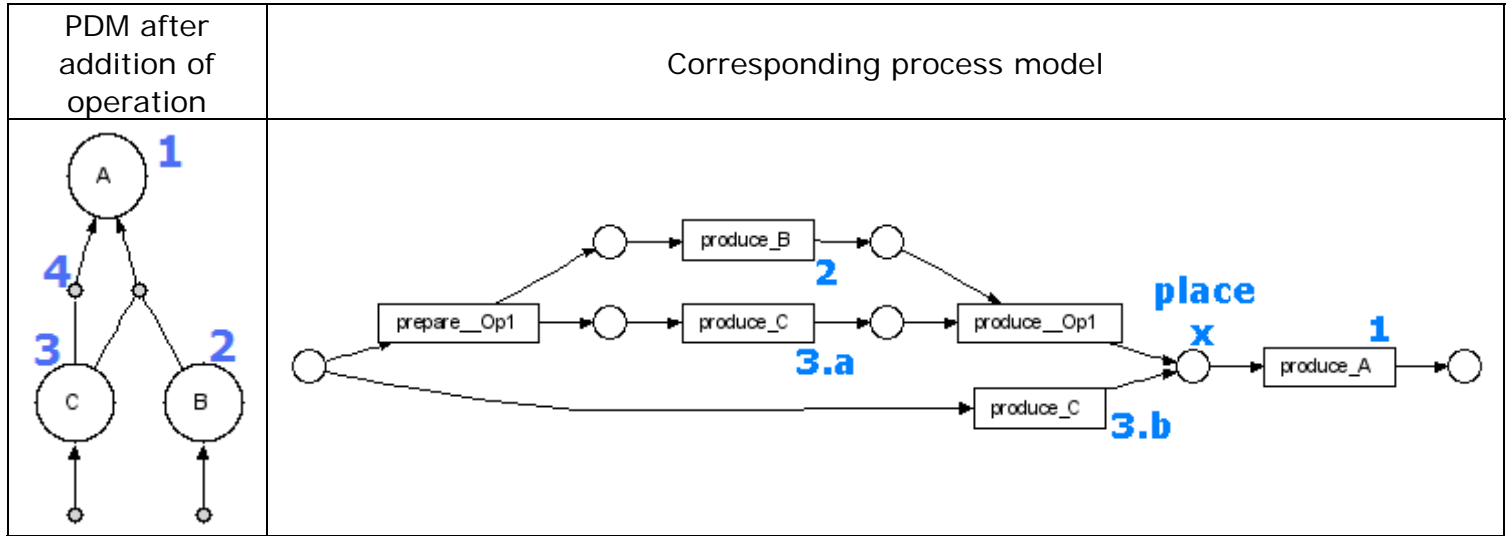

Figure 2.1.4 – PDM and process model after addition of operation (Alpha)

2.1.3. Alpha : Deletion of a data element

In this section we investigate the case of deleting a data element from the product data model. This is the data element, numbered 4 in the product data model in Figure 2.1.5. Figure 2.1.6 shows the models where the data element has been deleted.

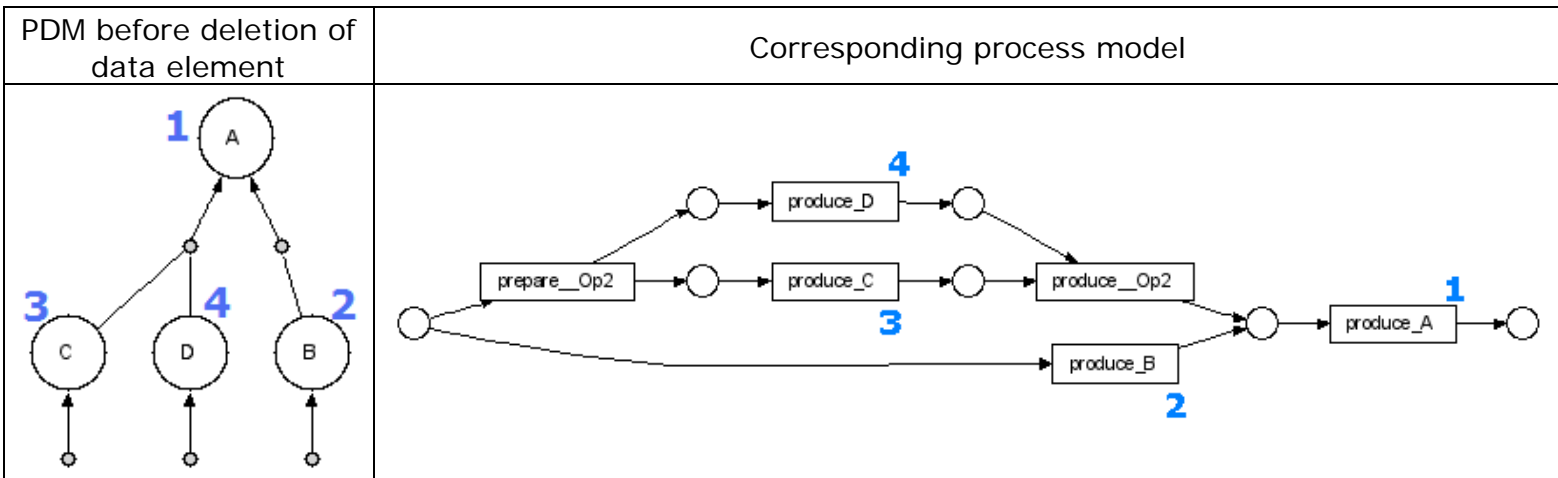

Figure 2.1.5 - PDM and process model before deletion of data element (Alpha)

Removing a data element from the product data model results in the removal of the corresponding transition in the process model and consecutively cleaning up the process model according to the rules of the algorithm (removing prepare and produce transitions that are superfluous after the deletion).

In this case data element *D*, indicated with number 4 in Figure 2.1.5, will be deleted from the product data model in Figure 2.1.5. As data element *D* is needed in conjunction with *C* to produce *A* in the above model, there is a “parrallel construction” in the process model, beginning and ending with transitions *prepare_Op2* and *produce_Op2* respectively.

Deleting data element *D* will remove the conjunctive property of the following operation, and therefore the parallel construction will be replaced with a simple branch, similar to the one which uses data element *B*.

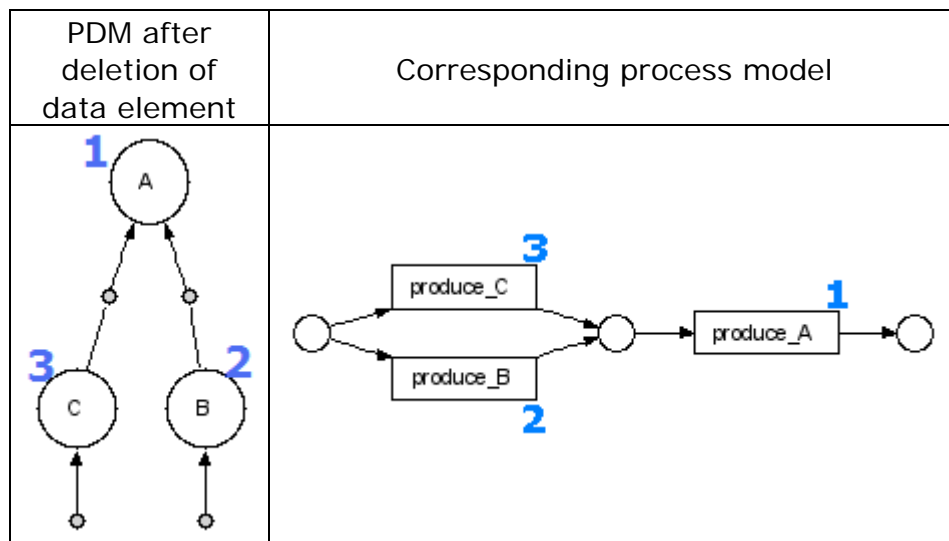

Figure 2.1.6 – PDM and process model after deletion of data element (Alpha)

In Figure 2.1.6 the product data model and process model that result from the removal of data element *D* are depicted. The whole upper branch is replaced by a simple *produce_C* transition, as the parallel element in the branch has disappeared.

2.1.4. Alpha : Addition of a data element

The addition of a data element is discussed in this section. To the product data model in Figure 2.1.7 a new data element is added. This data element is going to be the new root element and will therefore get a new operation as well, to produce it. The new data element is indicated by number 5 in Figure 2.1.8.

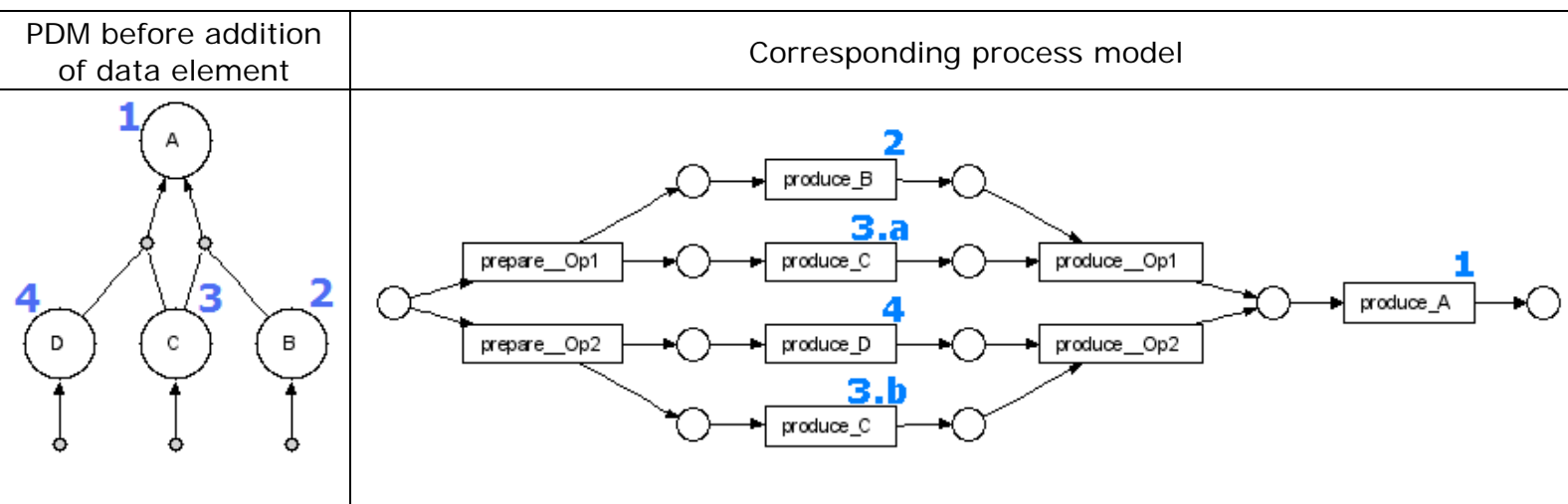

Figure 2.1.7 - PDM and process model before addition of data element (Alpha)

Adding a data element to the product data model, results in the addition of the corresponding producing transition to the process model. If this is in parallel to another, previously not parallel, branch, then prepare and produce transitions are added as well.

In this case a data element *New* is added to the top of the product data model. Adding the new root element *New* to the product data model, being only dependant on data element *A*, will result in the addition of a transition *produce_New* at the end of the process model in Figure 2.1.7 (and an arc from the end place to this transition and an arc from the new transition to the new end place, which is also added). The result of this change is depicted in Figure 2.1.8.

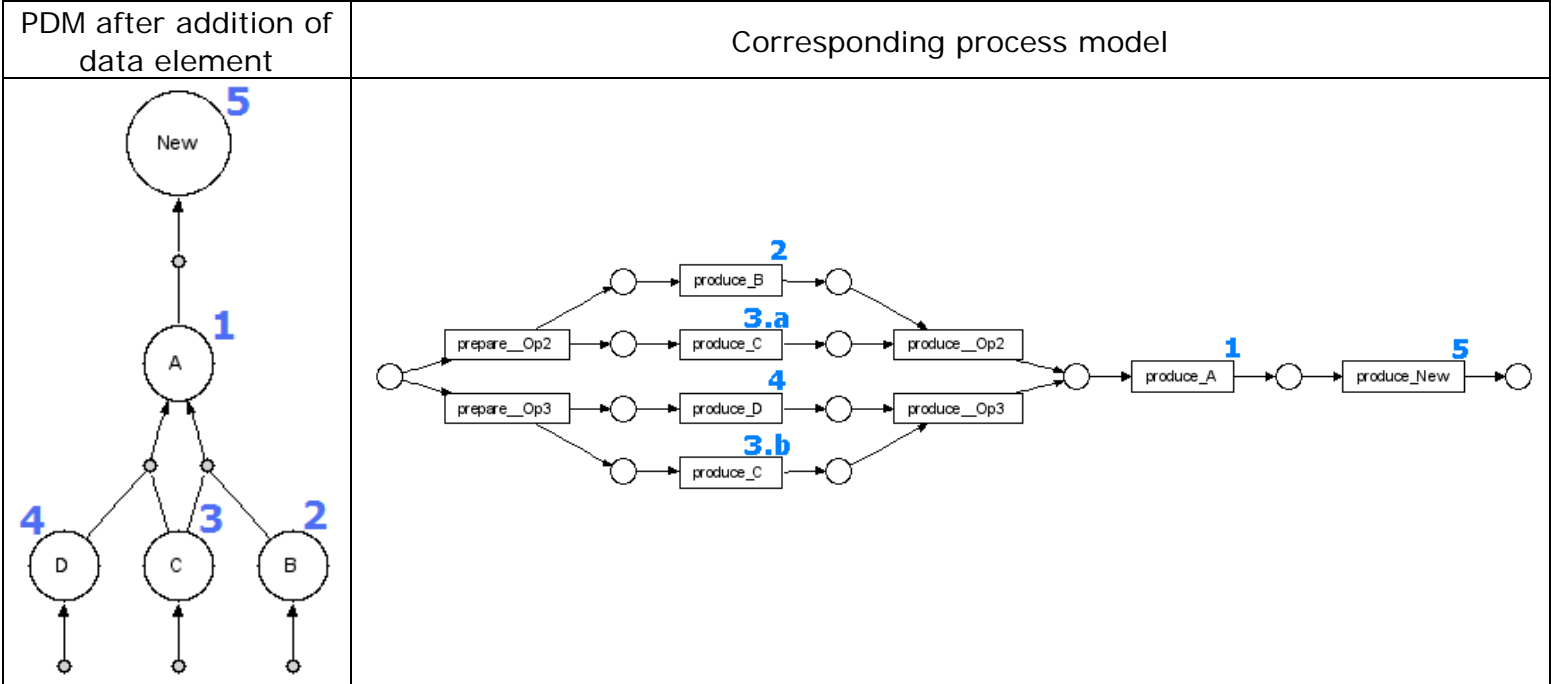

Figure 2.1.8 – PDM and process model after addition of data element (Alpha)

2.1.5. Summary of basic change primitives with algorithm Alpha

With the addition primitives, a new transition is added to the process model, representing the added operation or operation producing the added data element, at the location(s) where the required input elements have been determined.

If this addition results in the creation of a new parallel path to a path previously not in parallel, there are also prepare and produce transitions added to where the parallel paths branch and come together respectively.

With the deletion primitives, all occurrences of the transition representing the operation producing the data element or the operation itself that is deleted from the product data model are deleted.

In addition to this, if by this deletion one of 2 parallel branches is removed, the prepare and produce transitions in front of and at the end of these branches are removed as well.

2.2. Algorithm Bravo

Algorithm Bravo also works top-down. First the possible paths are determined, next they are created top-down.

Each data element is represented by a place. When an operation needs two input data elements to produce its output element, there is a branching earlier on in the process model facilitating a parallel flow. The transition making that split and the output places of that transition are not representations of operations or data elements, but merely needed to facilitate a correct process structure.

Instead of focusing on data elements, this algorithm focuses on operations. The generated process model, represents operations as transitions.

As can be seen in Figure 2.2.1 the operations in the product data model, can be directly found in the process model. The operations in the product data model are numbered. These numbers return on the corresponding transitions in the process model.

2.2.1. Bravo : Deletion of an operation

In this section the effect of the deletion of an operation is investigated. In Figure 2.2.1 the product data model before deletion is depicted. In this model the operation that is deleted, is numbered 4. In Figure 2.2.2 the models after deletion are shown.

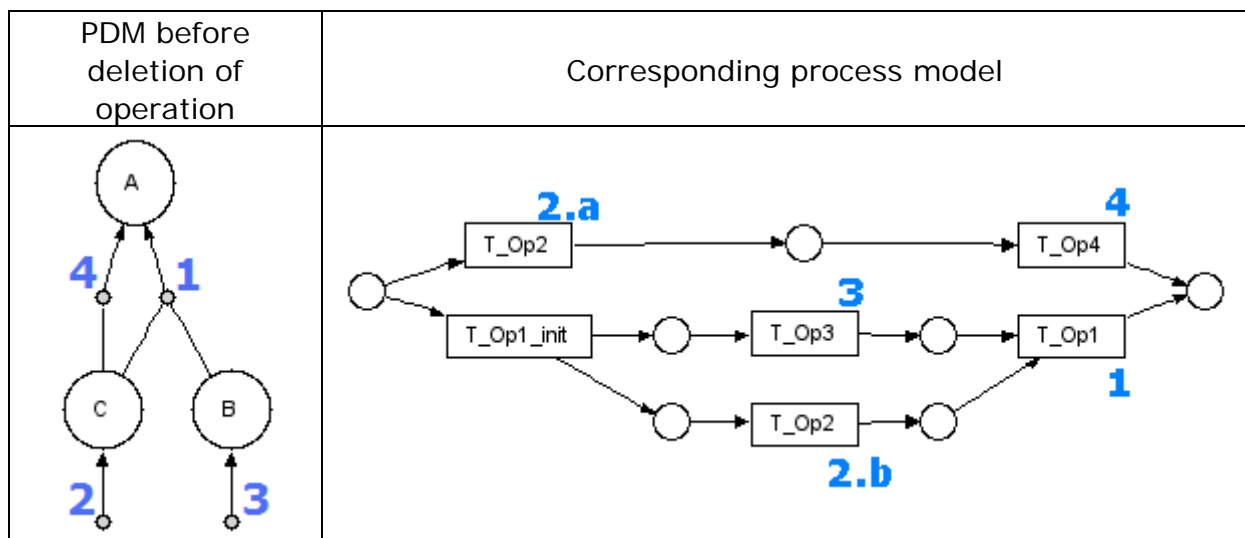

Figure 2.2.1 – PDM and process model before deletion of operation (Bravo)

As operations in the product data model are represented by transitions in the process model, the deletion of an operation results in the deletion of the corresponding transition and subsequently all “dangling” places and transitions (transitions or places either without incoming or without outgoing arcs (not being the start or end-place)).

Deleting the operation, labeled with number 4, in the product data model as depicted in Figure 2.2.1 results in the removal of the corresponding transition T_Op4 . This would leave a dangling section with the transition labeled as 2.a and

thus this branch from the process model, the upper branch in the same figure needs to be deleted. This has no further effects on the rest of the process model. The resulting process model is shown in Figure 2.2.2.

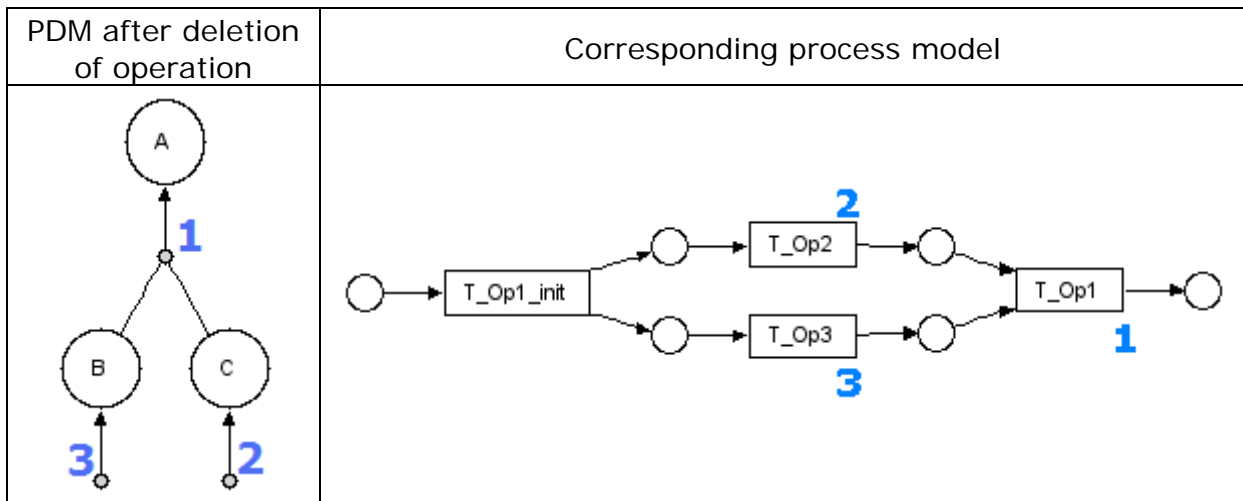

Figure 2.2.2 - PDM and process model after deletion of operation (Bravo)

2.2.2. Bravo : Addition of an operation

As described before, operations in the product data model are represented by transitions in the process model. Adding an operation to the product data model will therefore result in adding a transition to the process model. Due to the way this algorithm operates (early moment of choice), when a new operation is added and introduces an alternative way to produce a certain element, a parallel path in the process model will be created. This new path will be connected to the element to be created as output place, and branching off from the same point where the branch takes off that specifically leads to this element. In other words, parallel to the entire existing path(s) specifically creating this element.

A new operation is added to the product data model in Figure 2.2.3 as depicted in Figure 2.2.4.

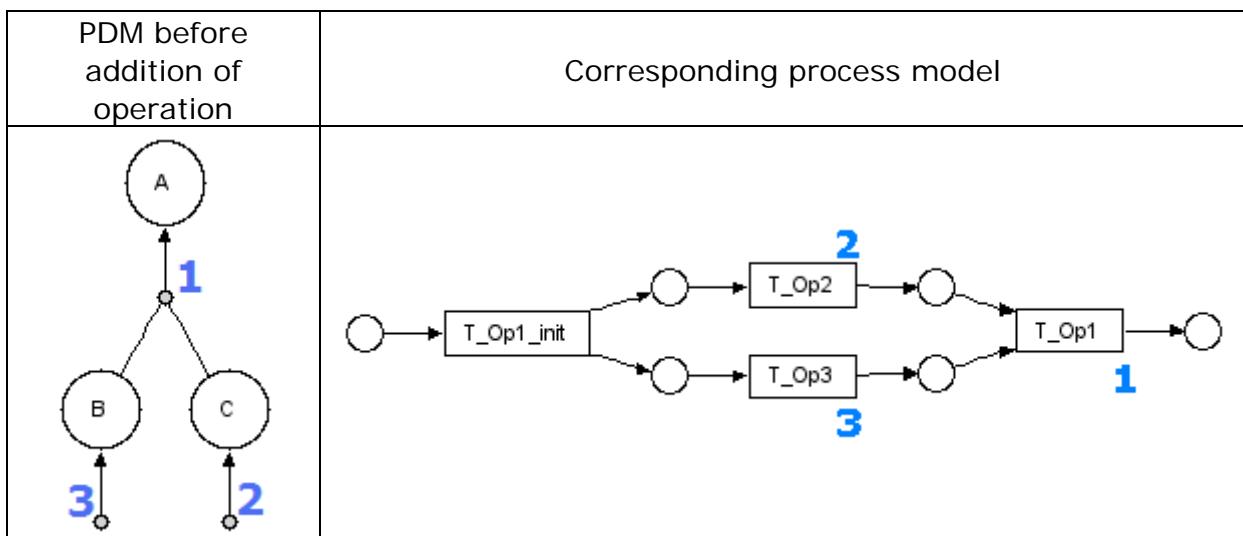

Figure 2.2.3 - PDM and process model before addition of operation (Bravo)

In the case of algorithm Bravo the added operation can easily be added to the process model. A new transition is added to represent the operation, and it is connected in the appropriate way. In this case, the new operation is a new way to reach the end product, separate from the "operation 1-branch". Therefore, a new branch is created, but before this new operation can be executed, data element C must be determined, which can be achieved in T_Op2 . Thus, T_Op2 is added at the front of this new branch (2.a), resulting in the process model in Figure 2.2.4.

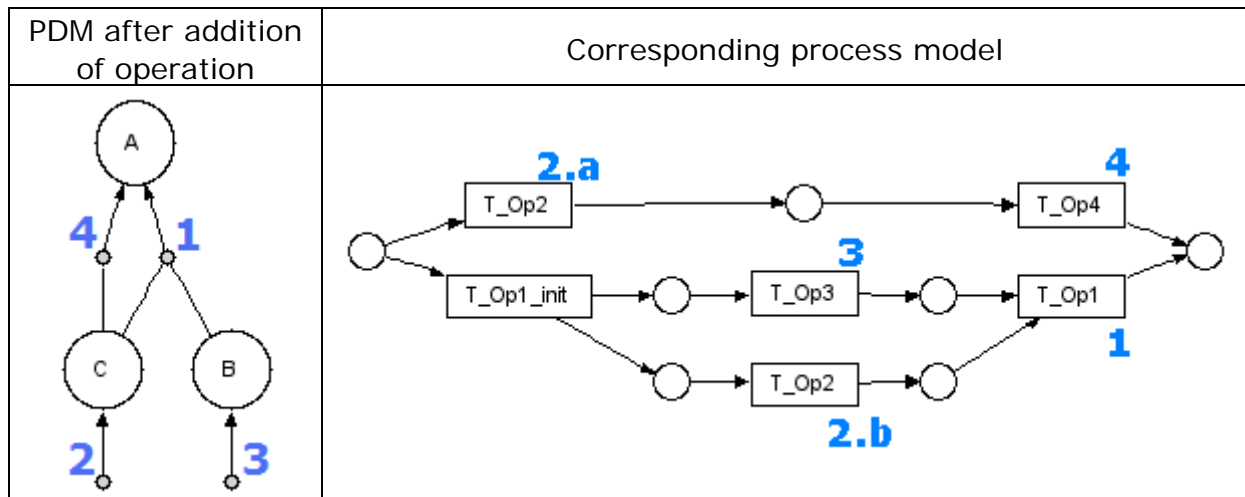

Figure 2.2.4 – PDM and process model after addition of operation (Bravo)

2.2.3. Bravo : Deletion of a data element

The deletion of a data element is discussed in this section. In Figure 2.2.5 the product data model before deletion is shown. The data element that is data element D . The product data model after the deletion is shown in Figure 2.2.6. The effect of the deletion on the corresponding process model is visible between the two figures, and discussed here.

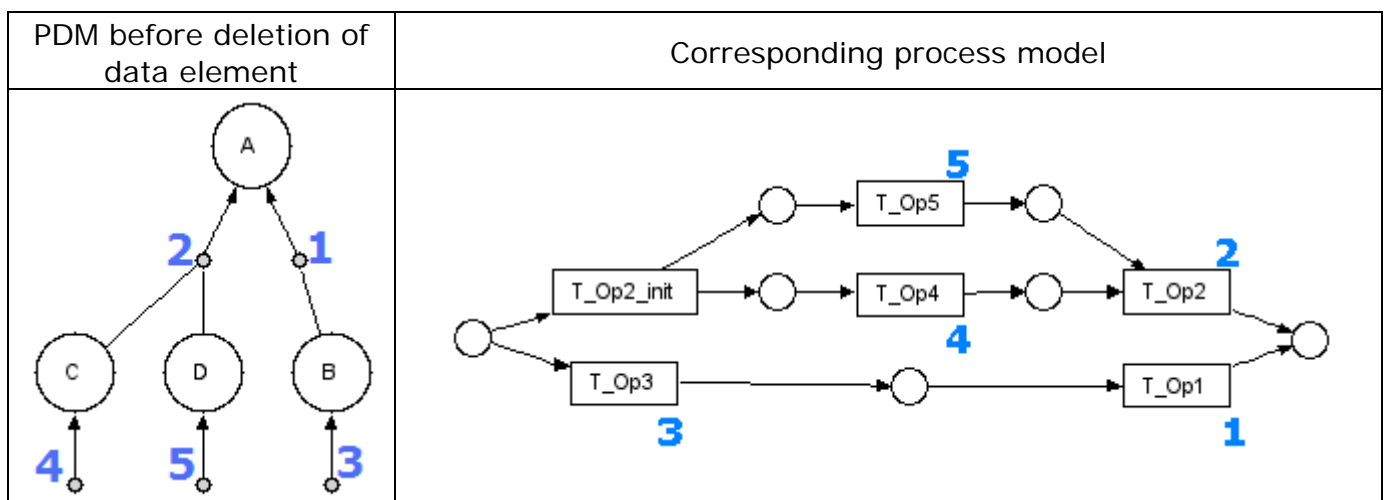

Figure 2.2.5 - PDM and process model before deletion of data element (Bravo)

If a data element is removed from the product data model, all operations using that element either can take place without it as well, or they should be removed from the model also, resulting in their dependant data elements getting the same treatment, etc. In this case data element *D* is removed, and the operation that used that element is supposed to still be able to work by just using data element *C*. If it wouldn't, the case of deleting an operation can be consulted.

Data element *D* is removed from the product data model in Figure 2.2.5. This means that the operation that used both elements *C* and *D*, will only use *C* in the altered situation. The transition labeled 5 is deleted, as it represents the operation creating data element *D* as can be seen in the product data model in Figure 2.2.5. Therefore, the whole parallel construction from the process model in Figure 2.2.5 can be replaced by a simple transition producing data element *C*. This results in a process model where either element *C* or *B* is produced, from where data element *A* can be produced.

This process model and the altered product data model are depicted in Figure 2.2.6.

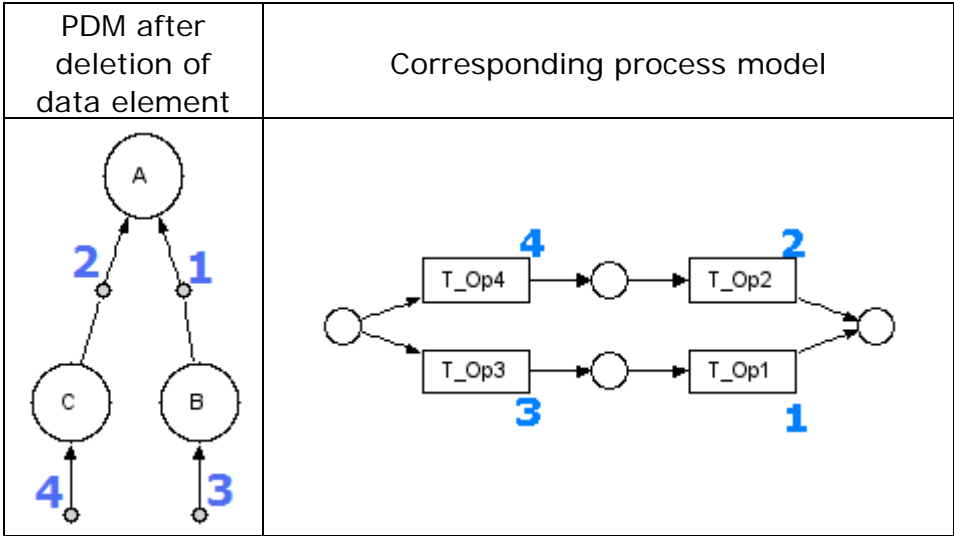

Figure 2.2.6 – PDM and process model after deletion of data element (Bravo)

2.2.4. Bravo : Addition of a data element

The final change to discuss is the addition of a data element. A new root element is added to the product data model as depicted in Figure 2.2.7. This means a new operation is added as well, to produce the new root element from data element *A*. In Figure 2.2.8 the product data model after the addition is shown.

Adding a data element to the product data model results in a new place in the process model, and transitions to connect it in the right way.

If it is added as an additional input element to an existing operation, there are two possibilities: either the operation had only one input element, or multiple. In the latter case, the corresponding transition is added in parallel to the already parallel transitions for the other input elements.

If there was only one input element to the operation, a new parallel branching is introduced in the process model. This branching joins where the operation is

located. The split is as early as possible in the process (after earlier splits, which join later than this one).

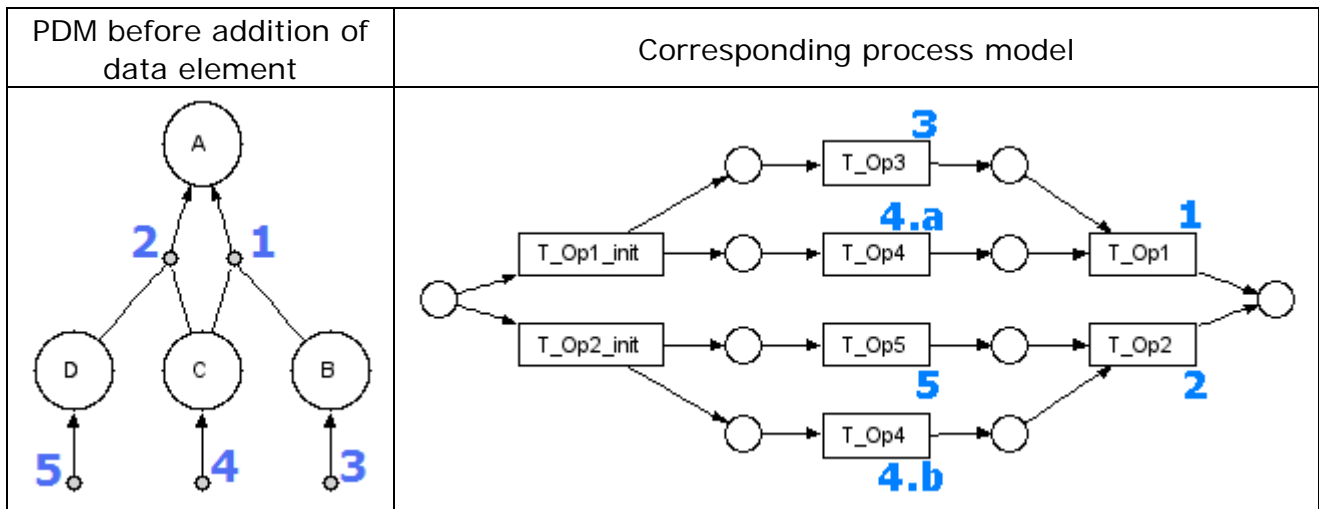

Figure 2.2.7 - PDM and process model before addition of data element (Bravo)

In this case a new root element is added to the product data model in Figure 2.2.7, and therefore a new place will be created at the end of the process model, connected to the old end place by a new transition firing into the new place. The rest of the process model remains unchanged as can be seen in Figure 2.2.8.

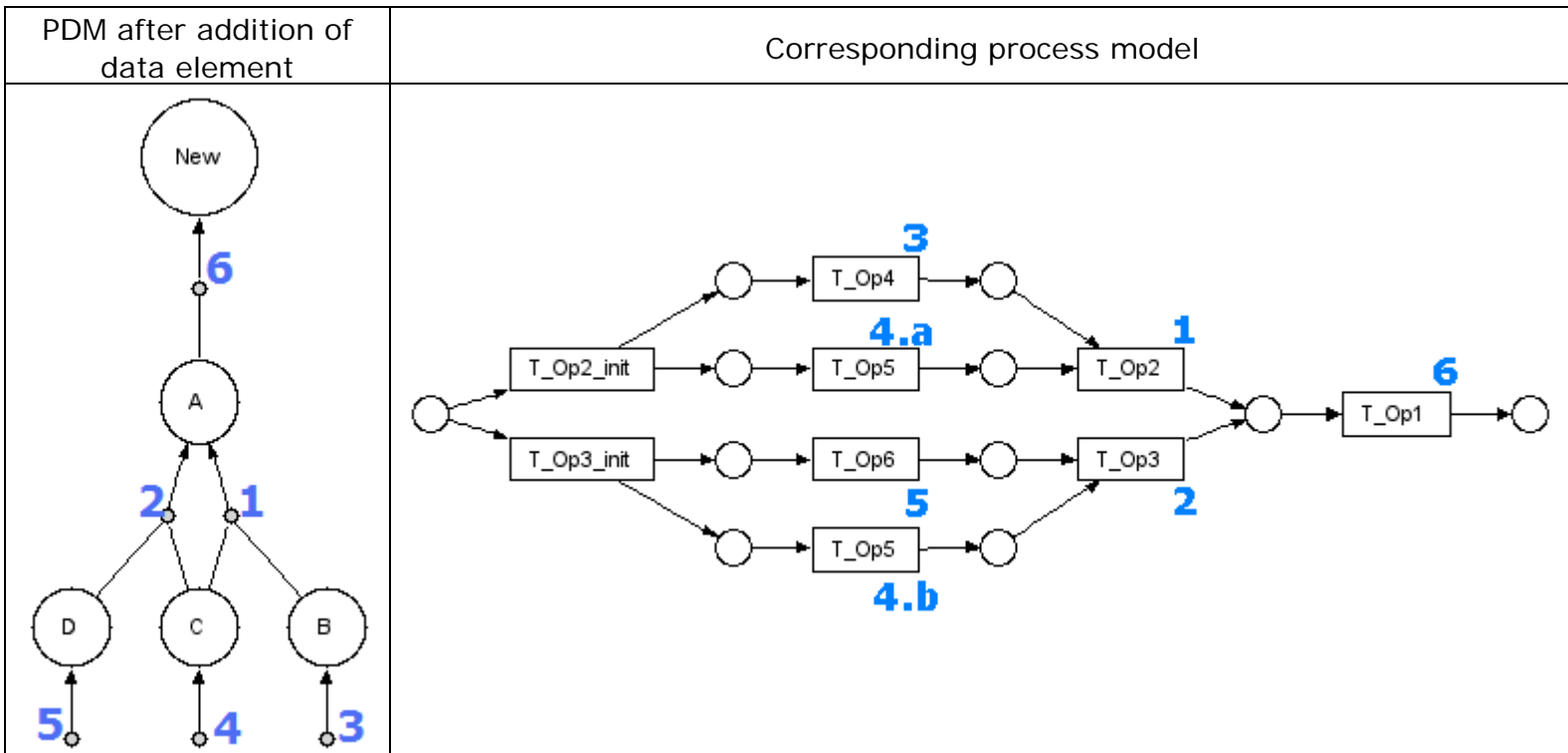

Figure 2.2.8 – PDM and process model after addition of data element (Bravo)

2.2.5. Summary of basic change primitives with algorithm Bravo

With the addition primitives, a new transition is added to the process model, representing the added operation or operation producing the added data element, at the location(s) where the required input elements have been determined.

If this addition means an existing operation gets an extra input element, and had only one input before, a parallel branch is created. In this case a transition is added at the start of this branch to facilitate the split in the process model.

If there is a new operation to create an element, the entire path to reach this operation is added as a branch, alternative to the existing branch leading to the alternative transition producing the same element.

With the deletion primitives, all occurrences of the transition representing the operation producing the data element or the operation itself that is deleted from the product data model are deleted. All dangling elements are removed subsequently.

In addition to this, if by this deletion one of 2 parallel branches is removed, the split transition in front of these branches is removed as well.

2.3. Algorithm Charlie

Algorithm Charlie has a middle-out order of generating the process model. First for all data elements a transition is created with input and output place. Next these constructions are connected through transitions representing the operations from the product data model.

Each data element is represented by a transition with an input and output place as can be seen in Figure 2.3.1. Operations are represented by transitions which fire to the input place of the transition corresponding to the data element that is produced by the operation. They use tokens from the output places of transitions representing the data elements that the operation is dependant on.

In Figures 2.3.1 to 2.3.8 the data elements and operations are numbered in the product data model. The corresponding transitions in the process model are numbered accordingly.

2.3.1. Charlie : Deletion of an operation

The first change discussed is the deletion of an operation. In Figure 2.3.1 the product data model is shown, from which an operation is deleted. The operation that is deleted is labeled with number 3. In Figure 2.3.2 the product data model after deletion is shown.

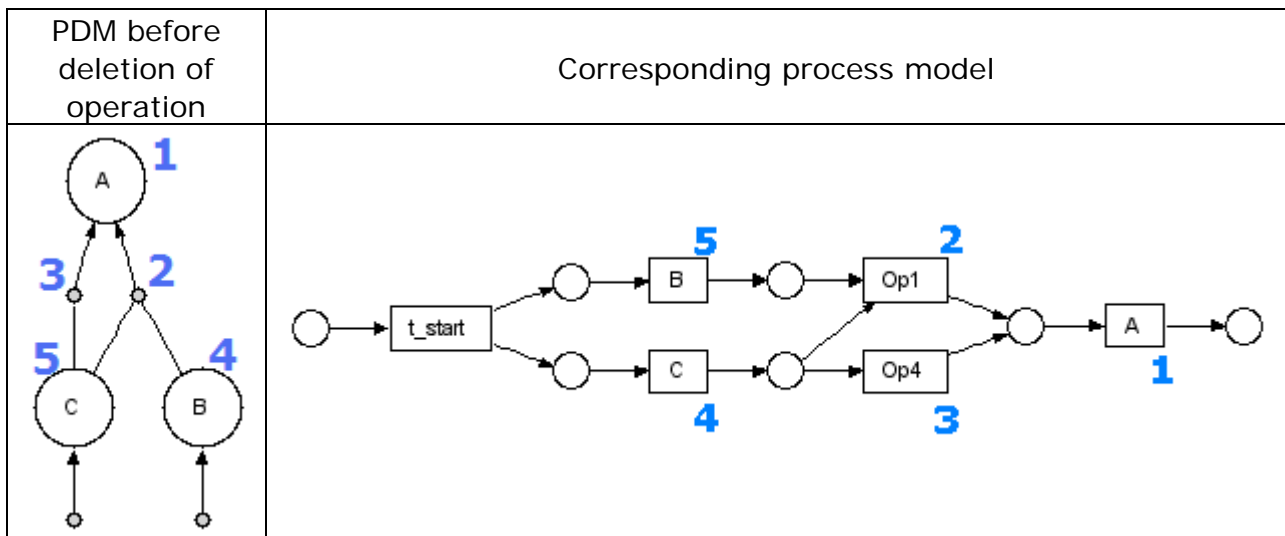

Figure 2.3.1 - PDM and process model before deletion of operation (Charlie)

As operations are represented by transitions, removing an operation from the product data model, results in the removal of the corresponding transition from the process model. All dangling sections are removed if present.

Removing an operation from the product data model, is as easily carried over to the process model, as removing the corresponding transition (in this case *Op4*). As in this case the input and output elements remain in the product data model, there are no dangling sections created in the process model, due to this removal. The rest of the process model is unaffected as seen in Figure 2.3.2.

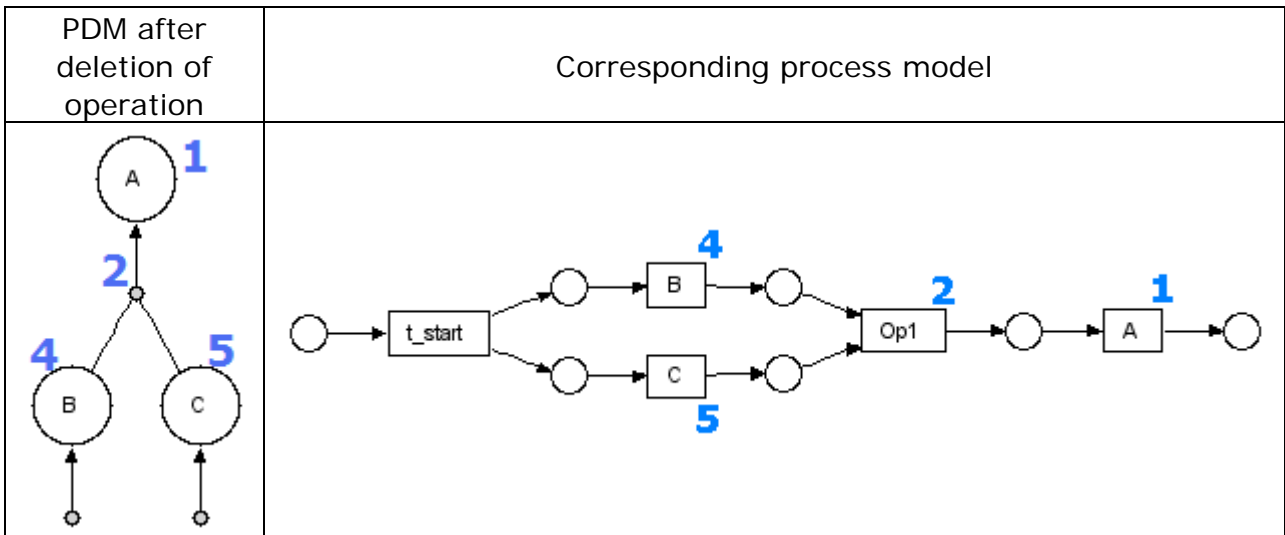

Figure 2.3.2 - PDM and process model after deletion of operation (Charlie)

2.3.2. Charlie : Addition of an operation

In this section the addition of an operation is discussed. Figure 2.3.3 shows the product data model and corresponding process model before addition. In this product data model a new operation is added, connecting data elements C and A directly. This new operation is added in the model in Figure 2.3.4 and labeled with number 3.

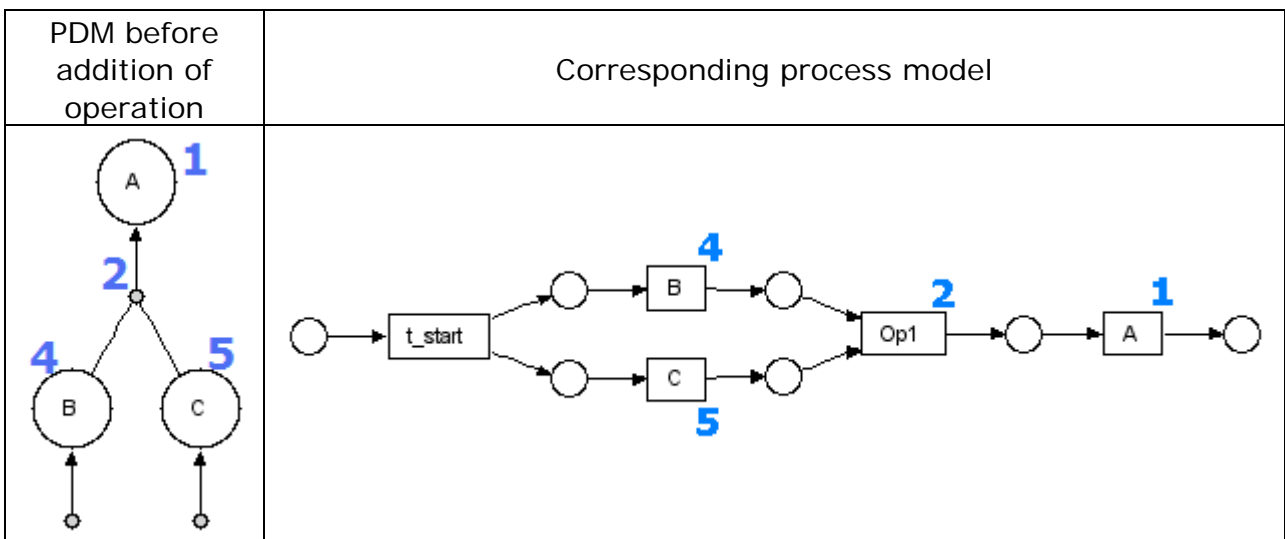

Figure 2.3.3 - PDM and process model before addition of operation (Charlie)

In algorithm Charlie, each data element and each operation is represented by a transition (with coupled input and output places in the case of a data element). If an operation is added to the product data model, a transition representing this operation should be added to the process model and connected to the output places of the transitions (using these as input places), corresponding to the data elements that are input elements to this operation. The new transition will have as output place the input place to the transition representing the production of the data element that can be created, executing the operation.

In this case, transition *Op4* is added, representing the operation that produces data element *A* using data element *C*. Therefore *Op4* has the output place of transition *C* as input place and the input place to *A* as output place as Figure 2.3.4 shows.

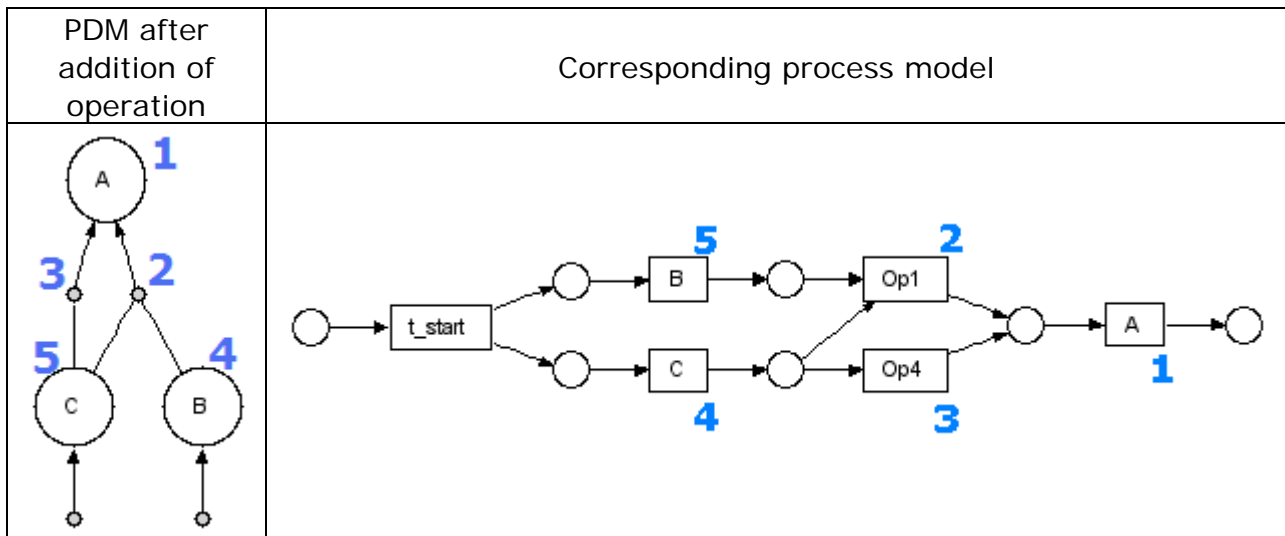

Figure 2.3.4 - PDM and process model after addition of operation (Charlie)

2.3.3. Charlie : Deletion of a data element

The deletion of a data element is the subject of this section. In Figure 2.3.5 the product data model before deletion is depicted. In Figure 2.3.6 data element *D* (labeled 6) is deleted. The effect on the corresponding process model is discussed here.

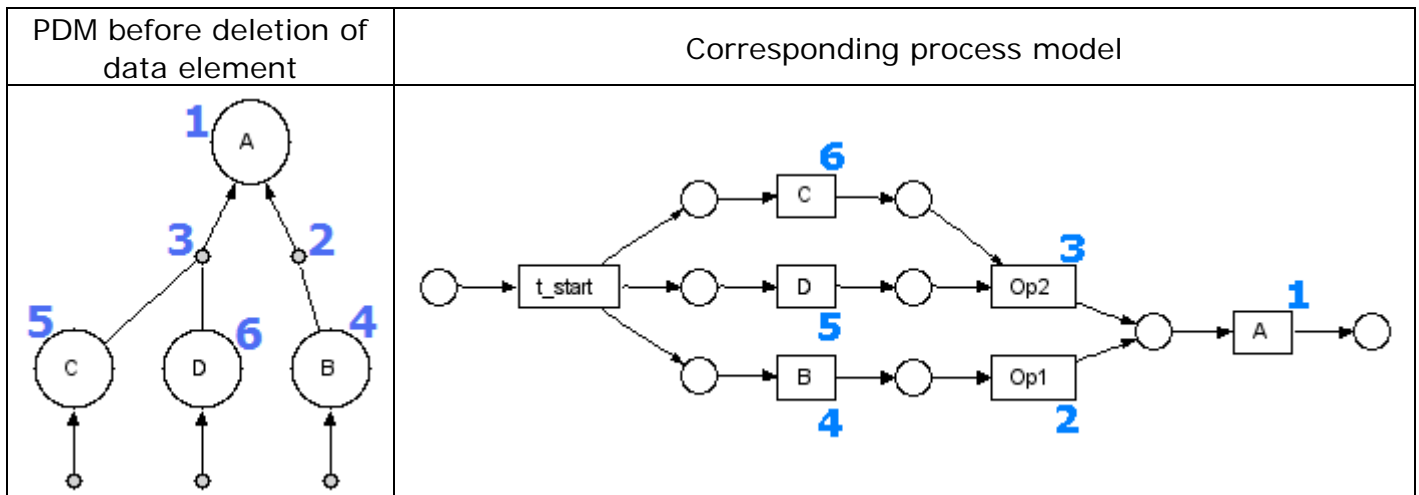

Figure 2.3.5 - PDM and process model before deletion of data element (Charlie)

Deleting a data element from the product data model will result in the removal of the place, representing the produced element, and also the operation creating the element. Subsequently any dangling sections are removed as well.

In this case one of the two input elements of operation 2 is removed. The operation is supposed to still be able to function using only the remaining data element. This means no dangling sections will result from the removal.

As data element *D* is deleted from the product data model in Figure 2.3.5, the corresponding transition *D* is removed from the process model, along with its output place (representing the produced data element *D*) and its input place. The rest of the model will be unaltered, as Figure 2.3.6 shows.

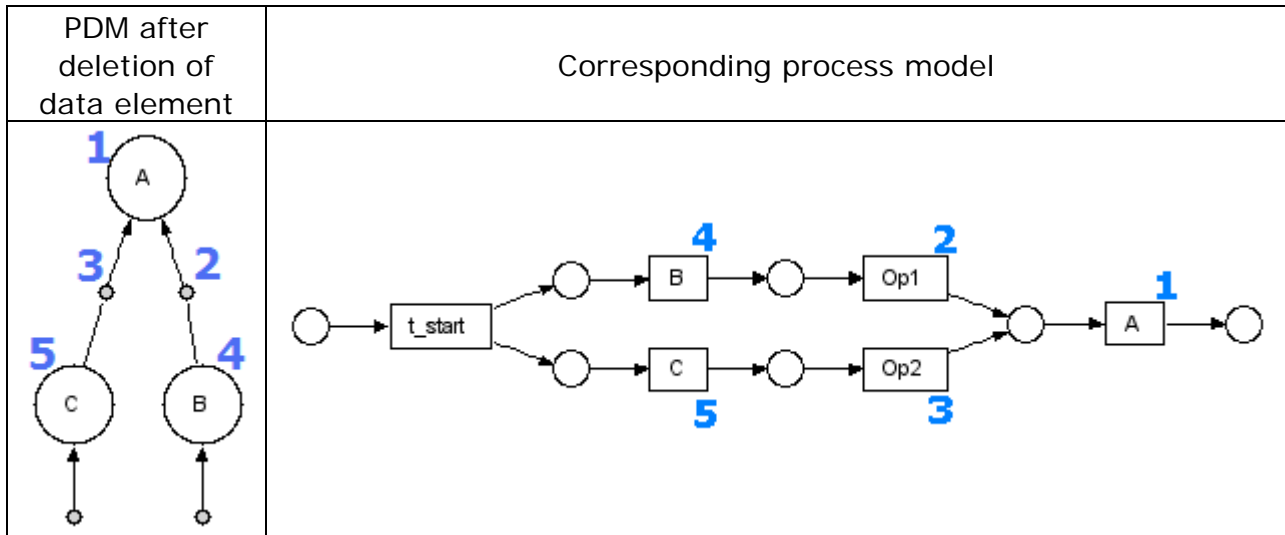

Figure 2.3.6 – PDM and process model after deletion of data element (Charlie)

2.3.4. Charlie : Addition of a data element

In this section the addition of a data element is discussed. A data element is added to the product data model shown in Figure 2.3.7. The new data element is also the root element, which means an operation should be added to create this new element from current root element *A*. In Figure 2.3.8 the product data model after the addition is depicted. In this model the added data element is labeled *B* and the added operation is labeled 7.

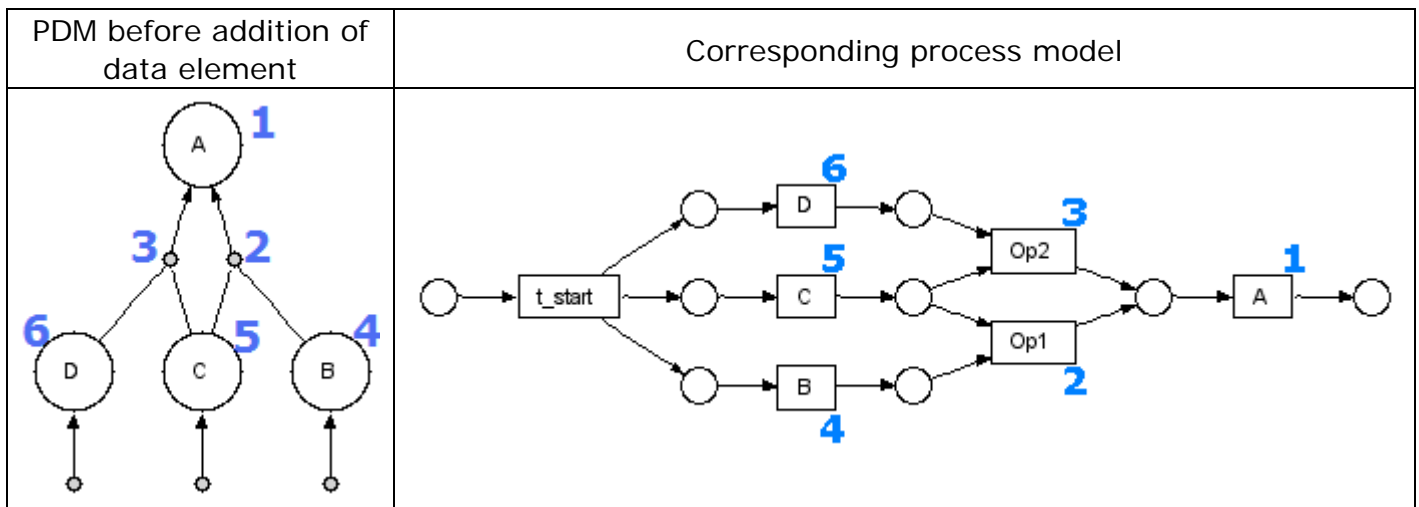

Figure 2.3.7 - PDM and process model before addition of data element (Charlie)

Adding a data element to the product data model results in the addition of two transitions in the corresponding process model: a transition representing the producing operation and one that represents the data element itself. These are connected in the right way with the rest of the process model (using as input the places where the input elements have been determined).

In this case a new data element *New* is added as new root of the product data model in Figure 2.3.7. The process model will therefore be elaborated from the current end place, with a transition representing the operation, a place to shoot into, a transition representing data element *New* and a new end place to shoot into. The resulting product data model and process model are visible in Figure 2.3.8.

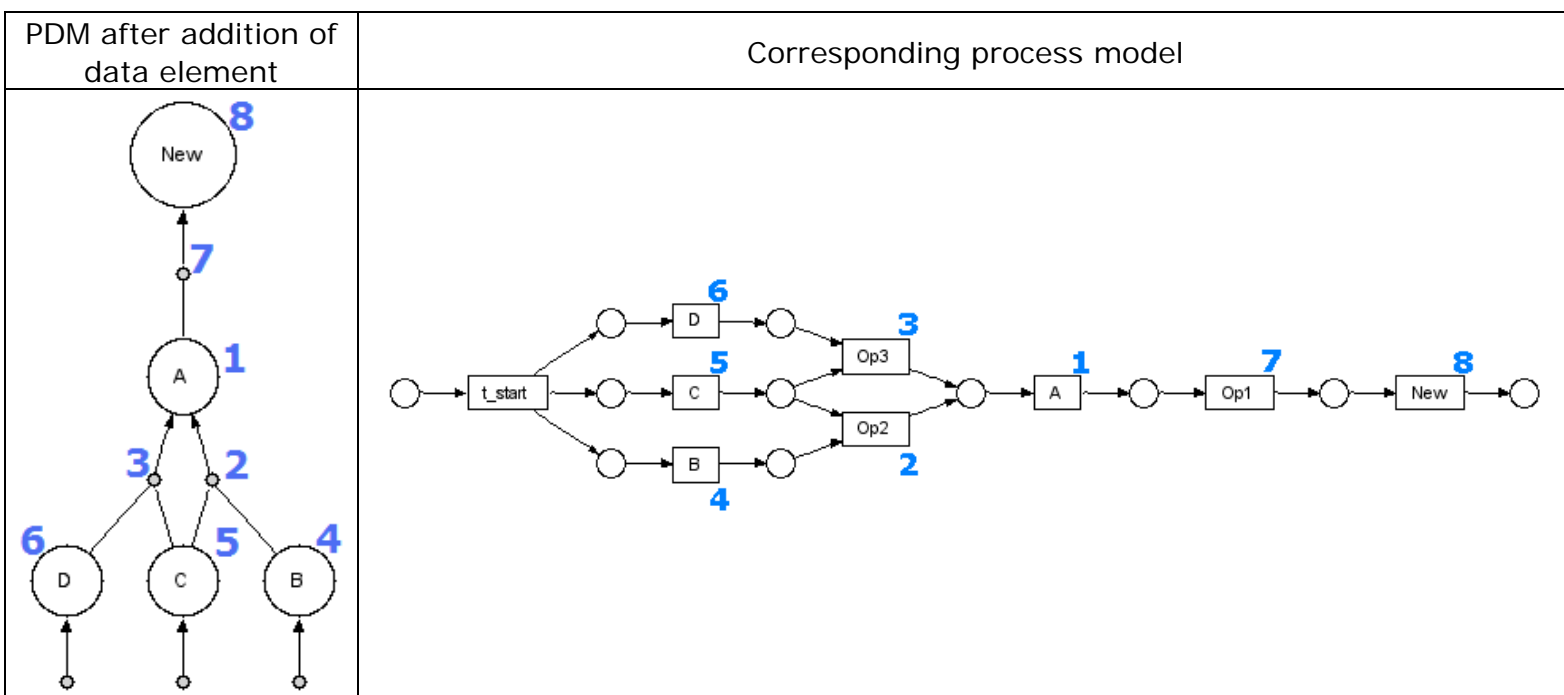

Figure 2.3.8 – PDM and process model after addition of data element (Charlie)

2.3.5. Summary of basic change primitives with algorithm Charlie

Each operation and each data element is represented by a transition. Therefore adding an operation or data element results in the addition of a transition or two, if the data element is produced by an operation that was not in the model yet. The added transitions representing operations use the appropriate places as input place, the places where either the input elements to the represented operation are determined. The transitions representing new data elements are added with connected input and output place. This input place is fired into from the transition that represents the operation creating the added data element. The output place is connected to the transition representing the operation using the added element as input element.

With the deletion primitives, the transition representing either the operation or data element that is deleted, is simply removed from the process model. Subsequently any dangling sections are deleted.

2.4. Algorithm Delta

The Delta algorithm constructs a process model from its product data model in a similar way to Algorithm Charlie. The generation is middle-out, first generating for each data element a transition with input and output place. Next connecting all these components through transitions (representing the operations) in the right way. And finally adding control places and cancellation arcs to make the process model sound.

In this algorithm each data element and each operation is represented by a transition and correctly connected through input and output places. Each operation has arcs from, but also to its input places, so data elements can be used by multiple operations. There are also control places in the model, to ensure that each transition can only fire once. Furthermore there are cancellation arcs to all places in the model, from the final transition, to ensure no tokens are left in the model when the end-place is reached.

In the figures the data elements and operations in the product data models have been labeled, to easily recognize the corresponding transitions in the process models that are labeled accordingly. In the case of Figure 2.4.1 root element *A* is labeled *1* for example, and in the process model it corresponds to the transition *A task* labeled *1* as well.

2.4.1. Delta : Deletion of an operation

The first change primitive that is discussed is the deletion of an operation. An operation is deleted from the product data model in Figure 2.4.1. This operation is labeled with number *5*. Without the operation all data elements in the model are still connected through the operation labeled *2*. So the deletion of the operation has no further effect on the product data model. The resulting product data model after the deletion is depicted in Figure 2.4.2.

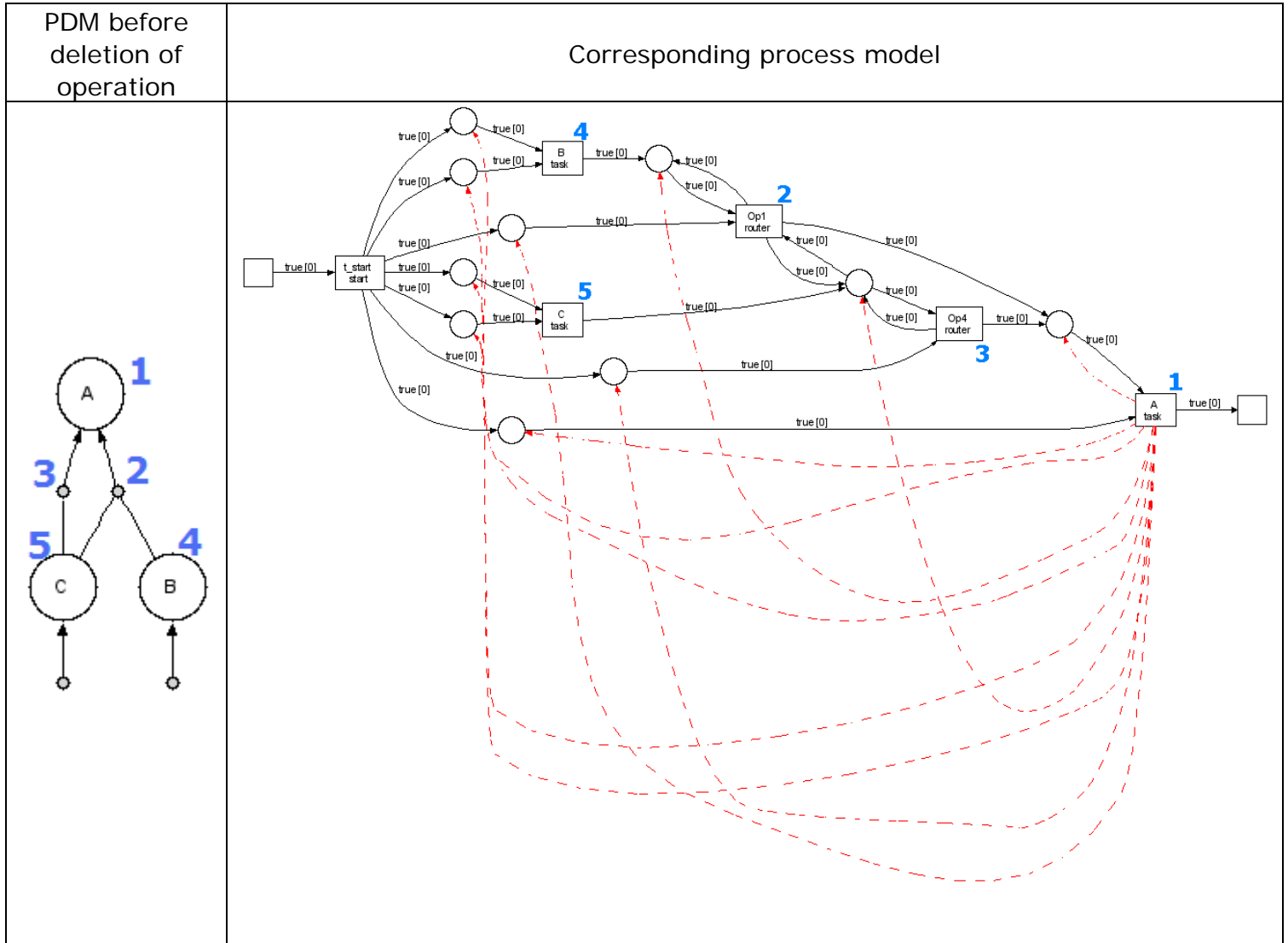

Figure 2.4.1 - PDM and process model before deletion of operation (Delta)

As operations (as well as data elements) are represented by transitions in the model created with Algorithm Delta, removing an operation from the product data model, results in the removal of a transition from the process model and the control place linked to it. Any dangling sections left due to the removal are deleted as well, where transitions with only incoming arcs from a control place, are considered to be dangling as well.

In this case the operation labeled 2 is removed from the product data model, creating data element A using only data element C. In Figure 2.4.1 this means that the transition labeled 2 is removed, together with its input place (control place) and all relevant arcs.

The resulting process model is depicted in Figure 2.4.2. Since the input element and output element to the deleted operation, are also input and output elements to another, still existing, operation, there are no dangling sections left in the model.

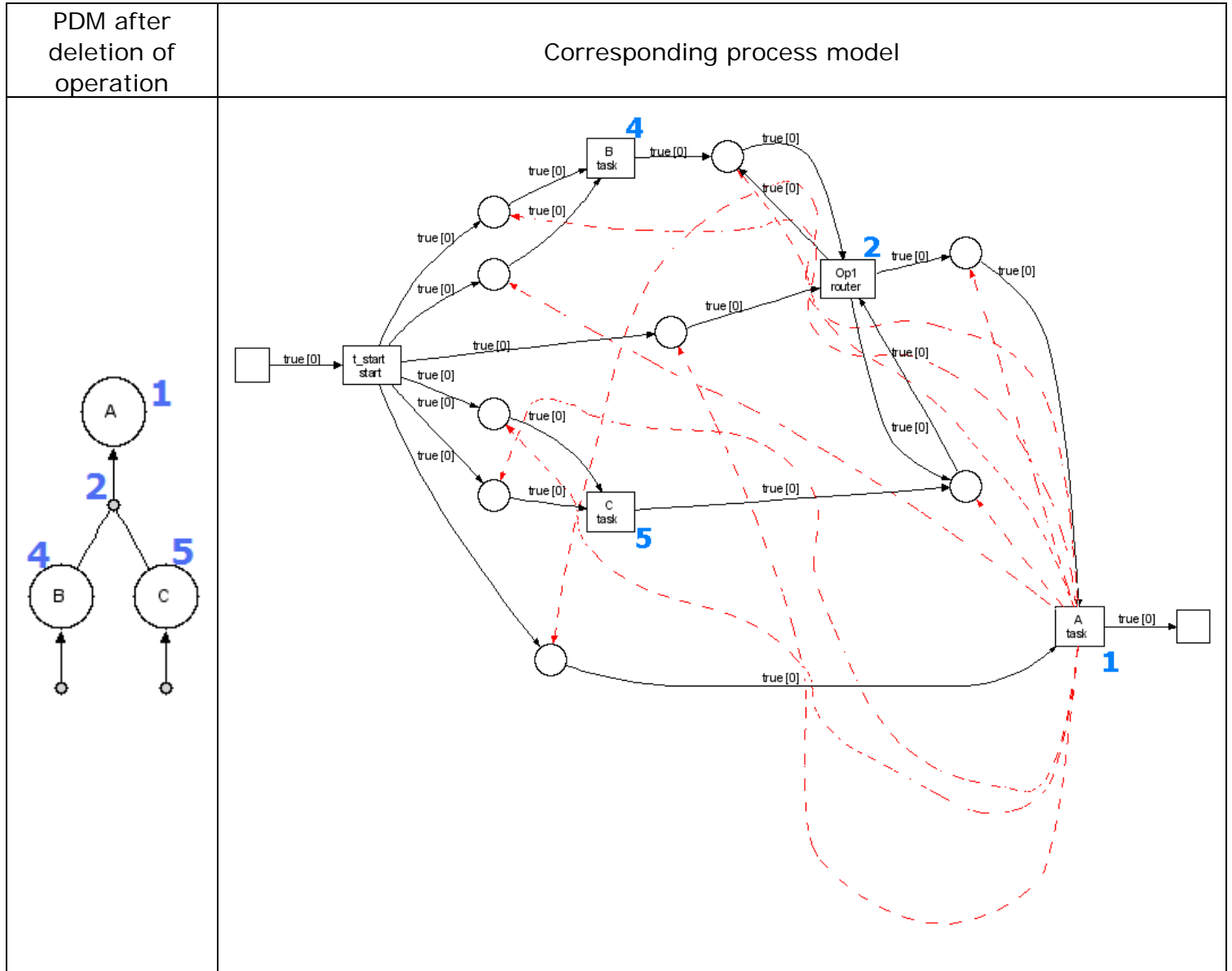

Figure 2.4.2 - PDM and process model after deletion of operation (Delta)

2.4.2. Delta : Addition of an operation

In this section the addition of an operation is discussed. Before the addition the product data model is as shown in Figure 2.4.3. In this model an operation is added, connecting data element C directly with A. In Figure 2.4.4 the new product data model is depicted, with the added operation labeled 5.

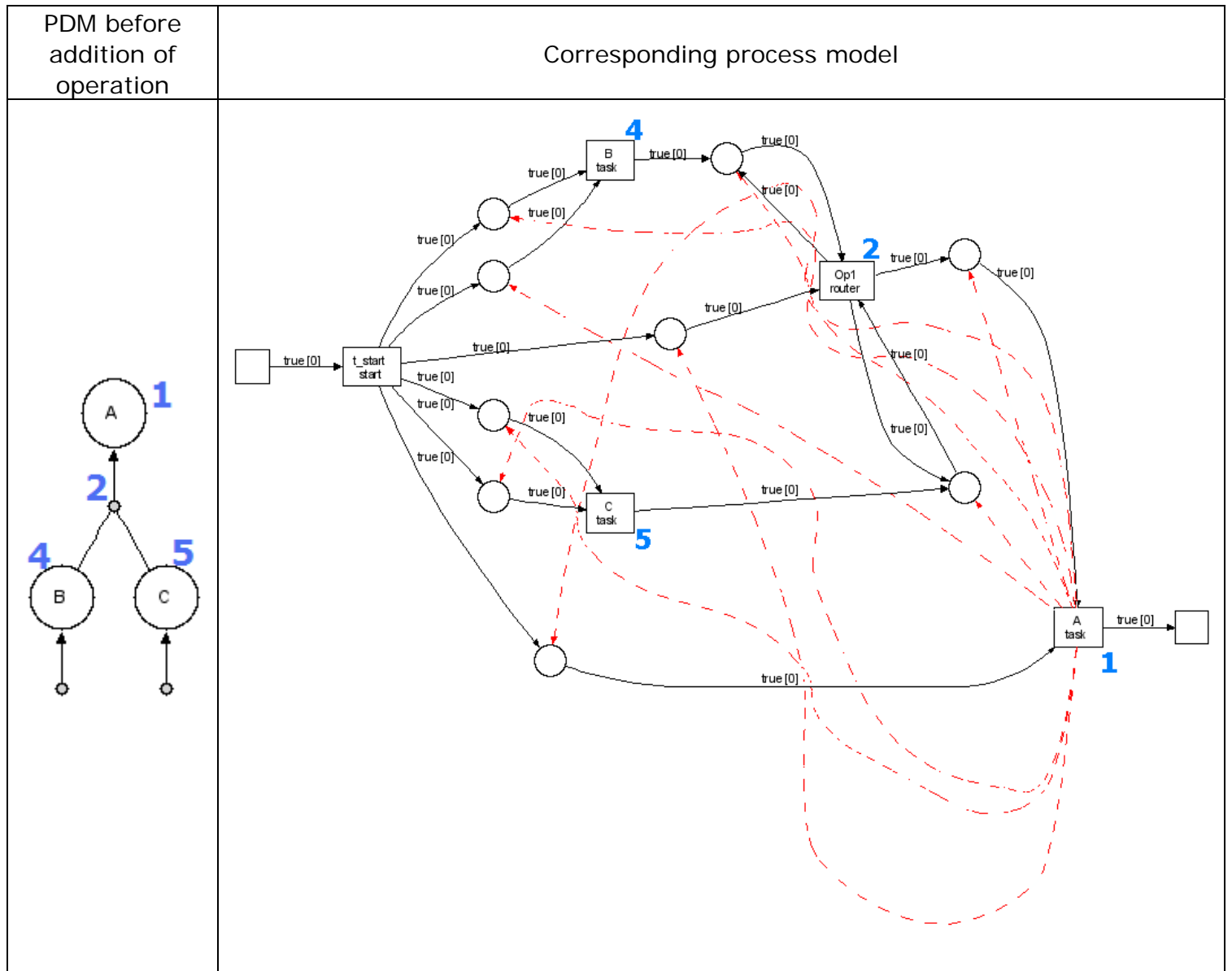

Figure 2.4.3 - PDM and process model before addition of operation (Delta)

With the Delta algorithm an operation is represented by a transition. Adding an operation to the product data model results in the addition of a transition to the process model.

This transition is connected in the right way. Input places are the places representing the input elements to the operation, output places are the places representing the output elements to the operation in the product data model.

There are also arcs added, returning to the input places to ensure other dependant transitions remain enabled. Besides these a control place is added as input place to the new transition without a returning arc, to ensure the transition can only fire once.

Adding an operation to the product data model in Figure 2.4.3 results in the addition of a transition to the process model. In this case an operation is added, creating data element A, by using only data element C.

Since all input and output elements to the operation are already represented in the product data model (and thus in the process model), there is only need to connect this new transition in the right way to existing elements. This new transition will get a new input place, connected to the *start* transition as control place like all transitions have.

The output place to transition *C task* is used as input place to the new transition and connected with a returning arc as well. This place represents data element *C* as input element to the operation.

The output place to the transition is the input place to transition *A task* which is obviously already present, and just connected through an arc.

Furthermore, a cancellation arc is added towards the new (control) place.

The result is depicted in Figure 2.4.4, where the added transition is labeled 5.

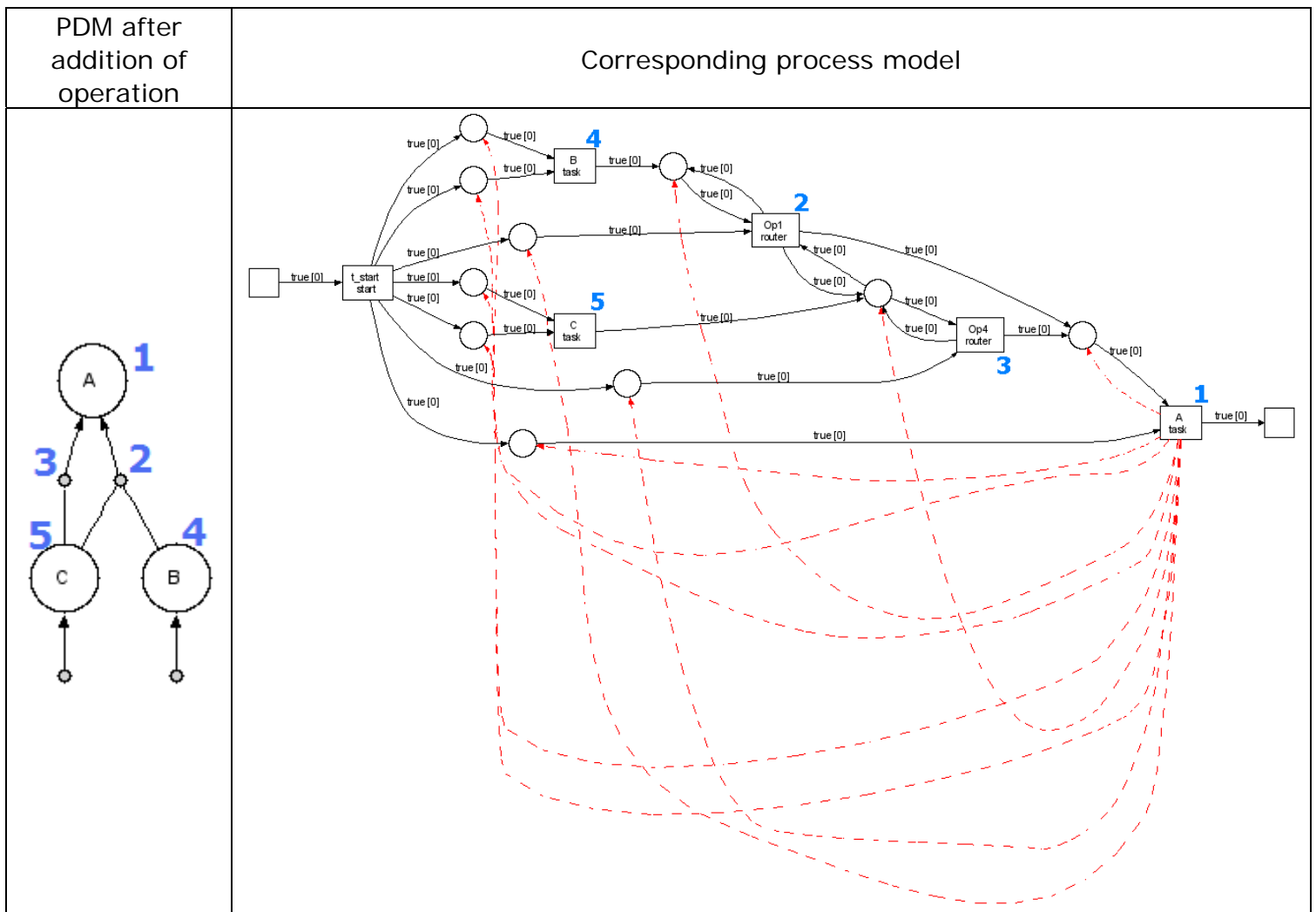

Figure 2.4.4 - PDM and process model after addition of operation (Delta)

2.4.3. Delta : Deletion of a data element

In this section the deletion of a data element is discussed. Figure 2.4.5 shows the product data model before deletion. The data element that is deleted is data element *D* also labeled 6. Figure 2.4.6 shows the product data model where this

data element is deleted. Deleting data element *D* also means the operation producing data element *D* is deleted as can be seen in Figure 2.4.6.

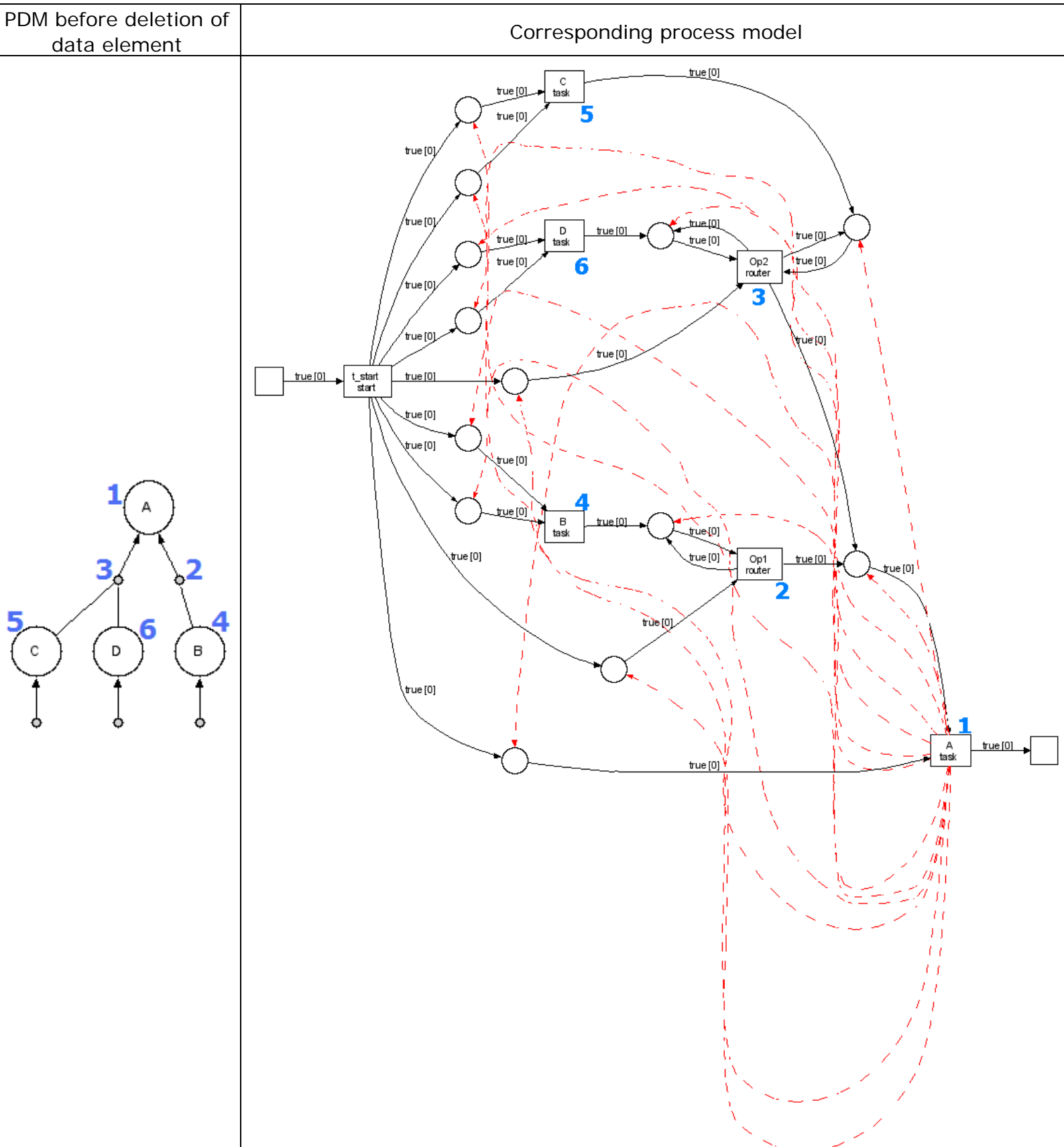

Figure 2.4.5 - PDM and process model before deletion of data element (Delta)

As both operations and data elements are represented by transactions in models generated with algorithm Delta, deleting a data element, will result in removing the corresponding transition from the process model along with any places that are used as input or output place by no other transaction than the deleted one.

In this case data element *D* is removed from the product data model in Figure 2.4.5, and therefore the transition representing this data element, *D* task, is removed from the process model, along with its input and output places. This results in the product data model and process model depicted in Figure 2.4.6.

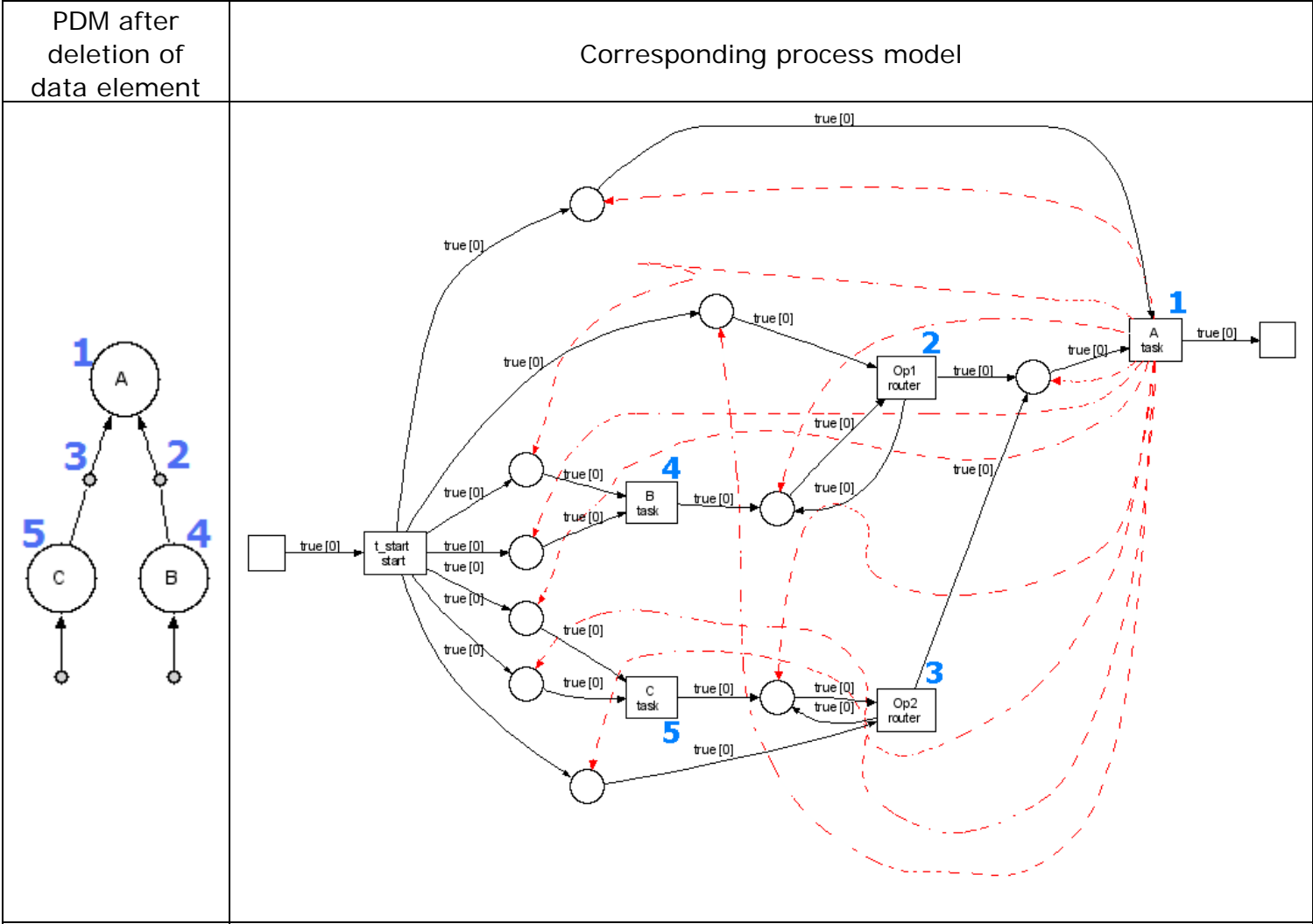

Figure 2.4.6 – PDM and process model after deletion of data element (Delta)

2.4.4. Delta : Addition of a data element

The final change primitive that is discussed concerning algorithm Delta, is the addition of a data element. If a data element is added, either an operation must be selected that will also produce this new data element, or, more commonly, a new operation is added as well. In this case a new root element is added to the product data model in Figure 2.4.7. As described, it also needs a new operation, which will produce the new data element, from data element A. In Figure 2.4.8

the product data model after the addition is depicted. Here the added operation and data element are labeled 7 and 8 respectively.

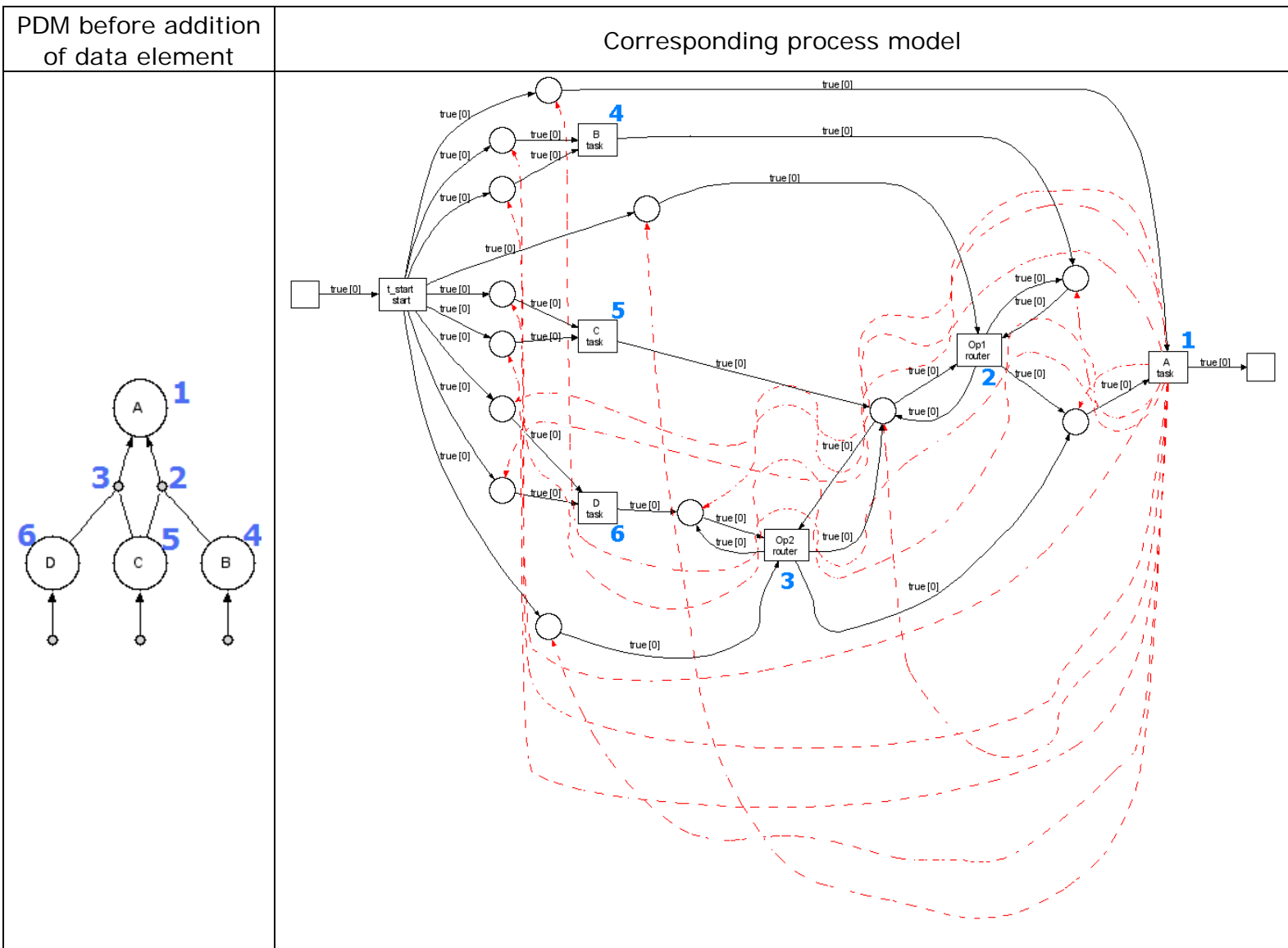

Figure 2.4.7 - PDM and process model before addition of data element (Delta)

Adding a new data element to the product data model results in a new transition representing this data element as well as a new place to function as control place.

There is also an input and output place added to the transition.

Also, a transition may be added, if a new operation is added to the model as well (see Section 2.4.2) creating the new data element.

In this case the data element to be added is the new root element *New* in the product data model. To add this new data element, a new operation needs to be added as well. It is only dependant on the former root element *A* and therefore in the process model the new transition representing the operation will be directly connected to the previous end-place (using it as input place). Following this

transition is the transition representing data element *New*, connected through a new place.

A new end-place is created and connected as output place to the last new transition. Also a control place is added and connected to both new transitions, to ensure they only fire once.

Apart from these changes, all cancellation arcs will now originate at the new last transition and three new cancellation arcs will be created; one towards the new control place, one towards the input place of the last transition and one towards the former end place of the process model.

The resulting product data model and process model are depicted in Figure 2.4.8.

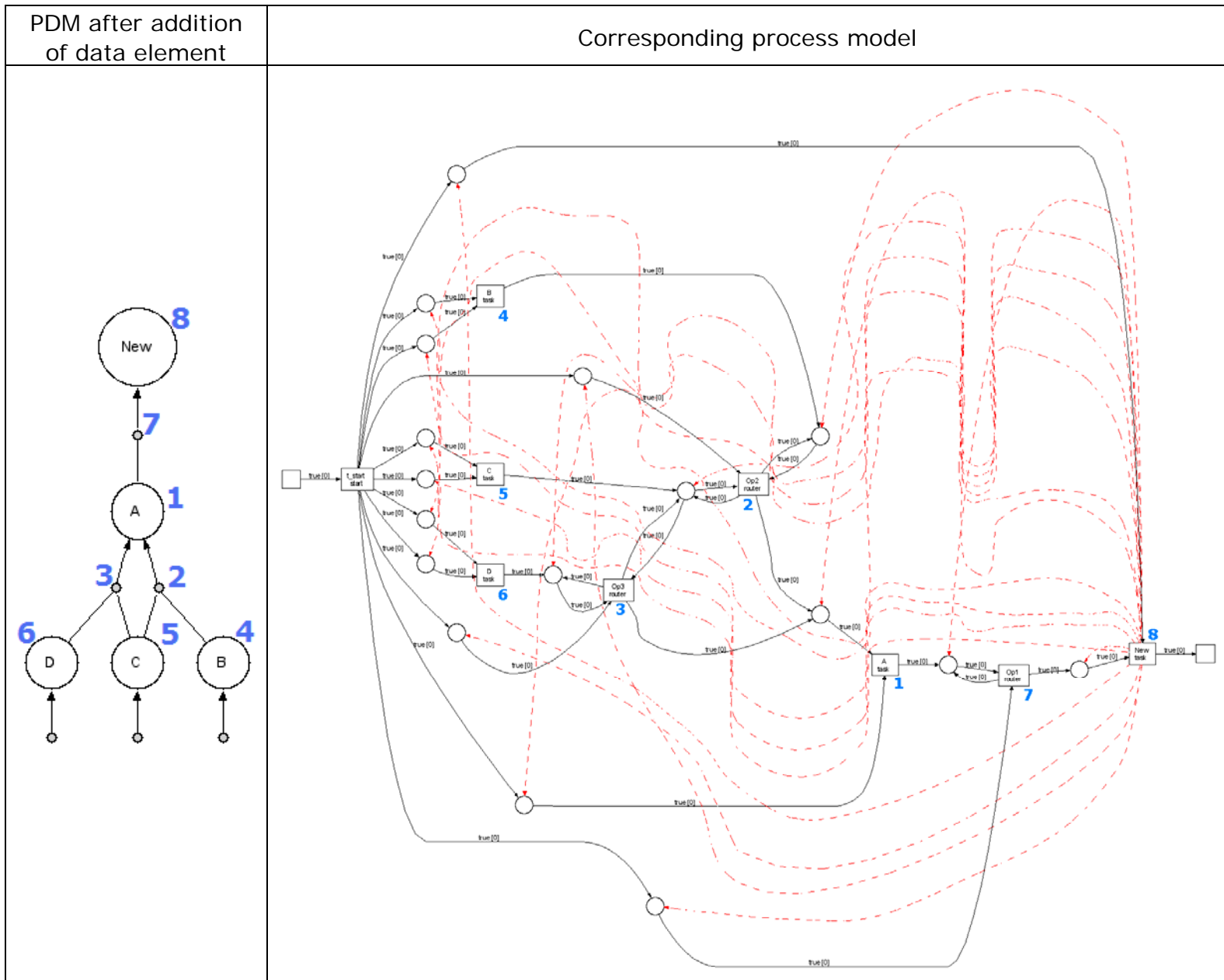

Figure 2.4.8 – PDM and process model after addition of data element (Delta)

2.4.5. Summary of basic change primitives with algorithm Delta

Data elements are represented by a transition with an input and output place. Operations are represented by transitions, that connect the right output place with the right input place of transitions. Therefore adding an operation or data element results in the addition of a transition, with a connected control place and with connected places (with cancellation arcs) if representing a data element. Transitions representing operations are connected to the appropriate input and output places belonging to the output or input element representations.

With the deletion primitives, the transition representing either the operation or data element that is deleted, is simply removed from the process model. Subsequently any dangling sections are deleted.

2.5. Algorithm Echo

The Echo algorithm works in a middle-out order and is focused on operations. Algorithm Echo creates a transition for each data element, and connects it to an input place. Next, for each operation a transition is created with as much input places as the operation has input elements and the representing transitions are connected to these places. The transition itself is also connected to the input place of the transition representing the output element of the operation.

The algorithm creates one transition for each data element (with connected input place) and one transition for each operation in the product data model (with as many connected input places as there are data elements the operation uses in the product data model). Furthermore, an initializing transition is added as the first transition, to enable all paths, and a control place is added to ensure the process only produces the end product once (hence the ending transition is the only data element related transition with two input places in stead of one).

The structure of the product data model is evident in the corresponding process model. Each data element and each operation is represented by one transition. This makes for a very transparent relationship between process model and product data model. In Figure 2.5.1 an example of a product data model with corresponding process model is depicted, where the transitions in the process models are labeled according to the labels of the data elements and operations in the product data model. Every transition in the process model is related to an element or operation except for the initializing transition.

2.5.1. Echo : Deletion of an operation

The deletion of an operation is discussed in this section. The product data model before deletion is depicted in Figure 2.5.1. The operation that will be deleted is the one producing data element *A* by only using data element *C*, labeled with number 3. Deleting an operation like 3 does not influence the rest of the product data model, as all connected data elements are still used and produced by other operations (operation 2 in this case connects both data elements *C* and *A*). In Figure 2.5.2 the product data model and corresponding process model after deletion are depicted.

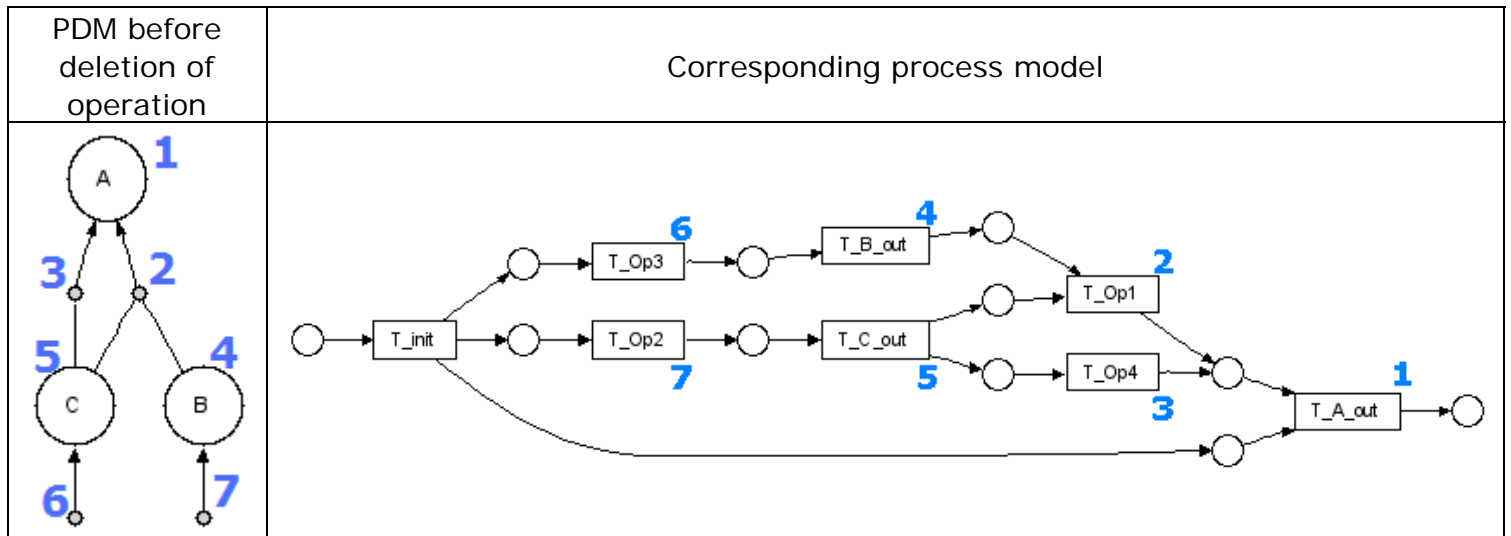

Figure 2.5.1 - PDM and process model before deletion of operation (Echo)

Each operation is represented by a transition in the process model. Removing an operation from the product data model, will therefore result in the removal of a transition in the process model, and subsequently any dangling sections.

In this case the operation producing data element A using only element C is deleted. This operation corresponds to *T_Op4* as can be seen in Figure 2.5.1. Figure 2.5.2 depicts the situation after removal of the operation from the product data model.

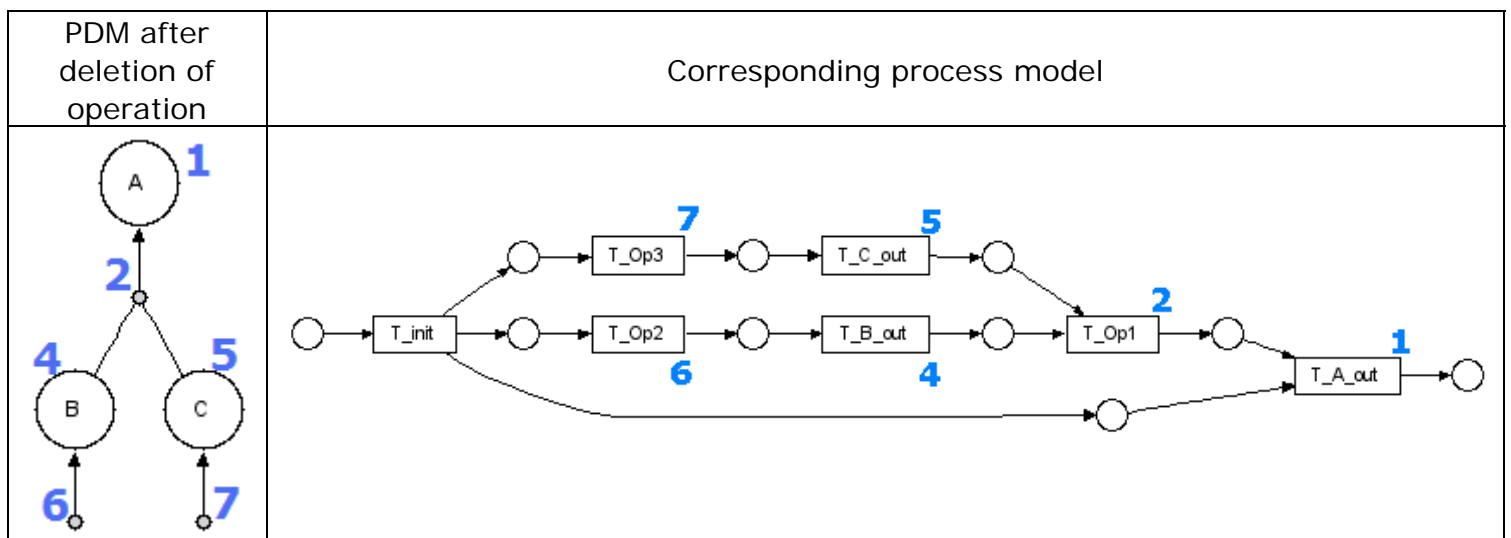

Figure 2.5.2 - PDM and process model after deletion of operation (Echo)

2.5.2. Echo : Addition of an operation

The next change primitive discussed, is the addition of an operation. An operation is added to the product data model depicted in Figure 2.5.3. This new operation connects data element C directly with data element A. In Figure 2.5.4 the product data model after addition is shown, and the added operation is labeled with number 3.

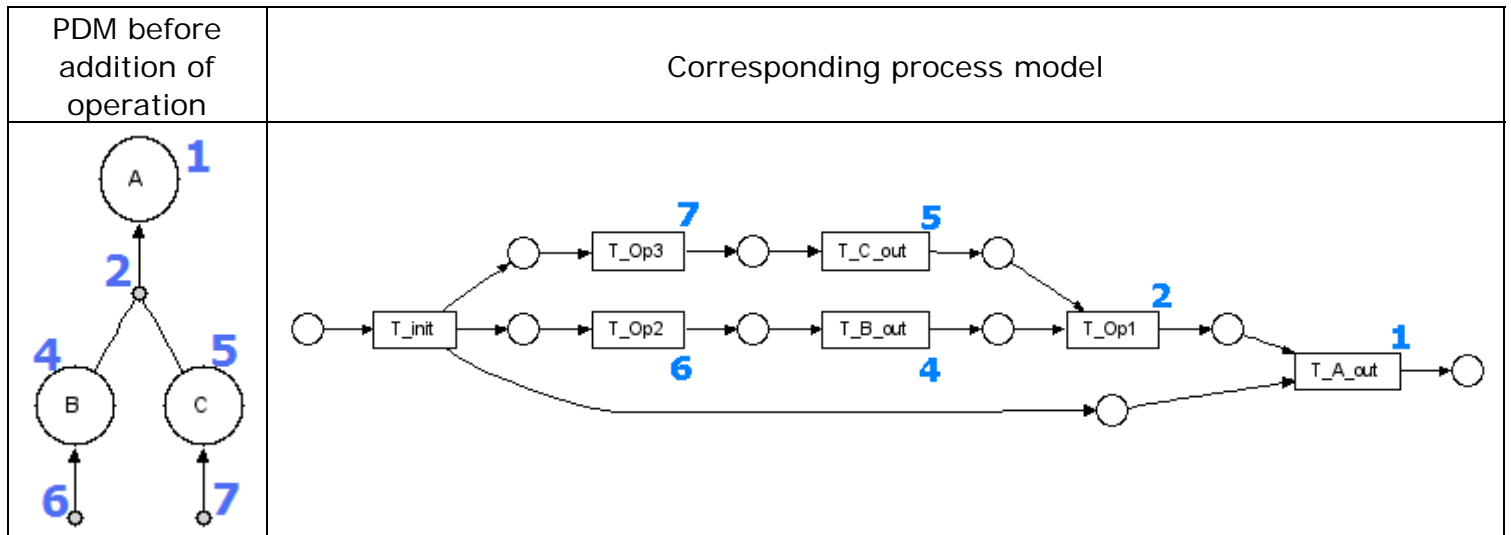

Figure 2.5.3 - PDM and process model before addition of operation (Echo)

Algorithm Echo represents an operation from the product data model as a transition in the process model. Adding an operation therefore results in adding a transition with the right amount of input places. The transitions representing the input elements to the added operation are connected to these input places.

In this case a new operation is added, using and producing data elements already existing in the product data model in Figure 2.5.3. This operation produces data element *A* using element *C*, as an alternative to the operation using both elements *B* and *C*. This means the transition representing this new operation (labeled 3 in the process model) will be placed in parallel to the already present operation, *T_Op1*, producing data element *A*.

Being in parallel, this transition shares its output place with *T_Op1*, because the represented operations produce the same data element. However it gets a separate input place due to the way the algorithm works, creating an input place for each input element to the operation.

The results of these alterations are visible in Figure 2.5.4.

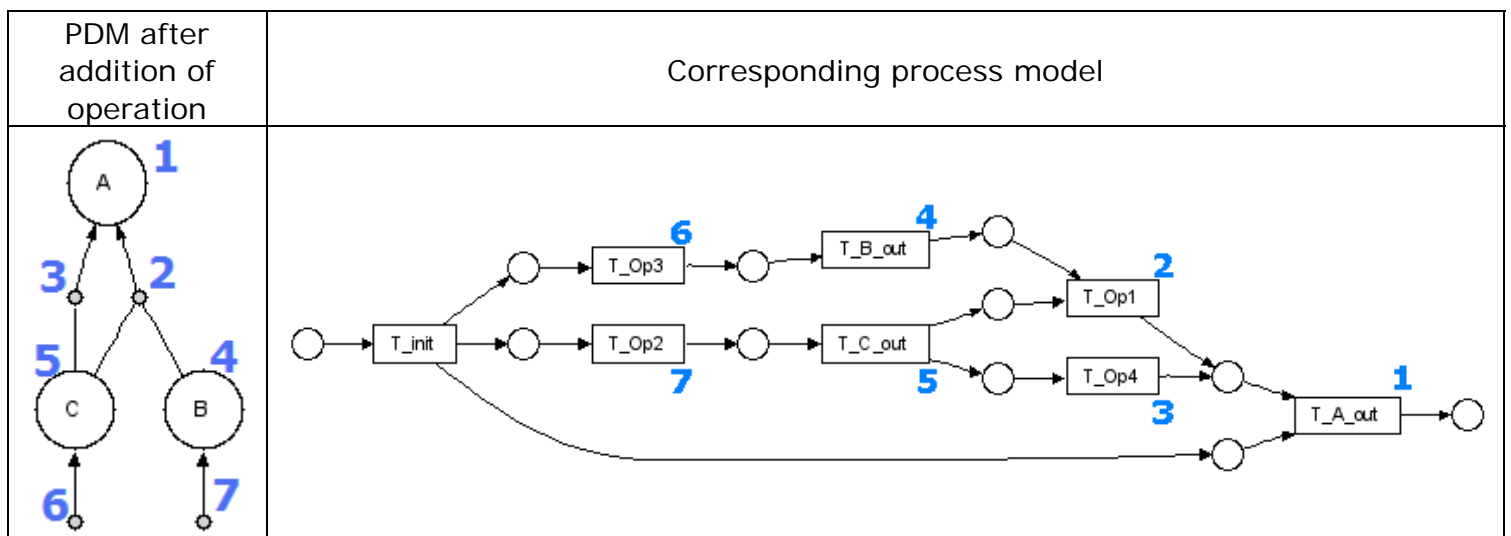

Figure 2.5.4 - PDM and process model after addition of operation (Echo)

2.5.3. Echo : Deletion of a data element

In this section the deletion of a data element is discussed. Data element D , labeled 6, is deleted from the product data model in Figure 2.5.5. Deleting this data element, means the operation producing it (labeled 9) is deleted as well. In Figure 2.5.6 the result of the deletion is shown.

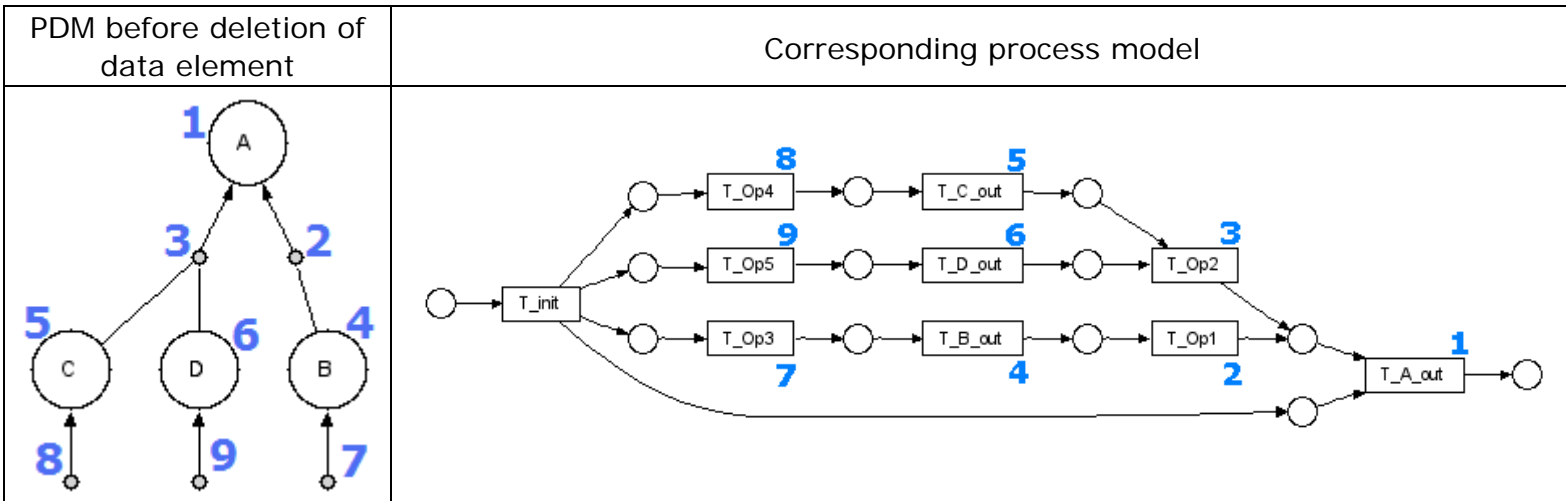

Figure 2.5.5 - PDM and process model before deletion of data element (Echo)

As each data element is represented by a transition in this algorithm, the deletion of a data element in the product data model results in the deletion of a transition in the process model and eventual dangling sections.

In this case data element D is deleted from the product data model in Figure 2.5.5. This affects the corresponding process model by the removal of the transition representing this data element, transition T_{D_out} , labeled 6. By deleting this transition, its output place is left without a transition using it as output place and therefore is deleted as well. Also operation T_{Op5} (labeled 9), producing data element D and its input and output places are deleted, leaving the process model as depicted in Figure 2.5.6.

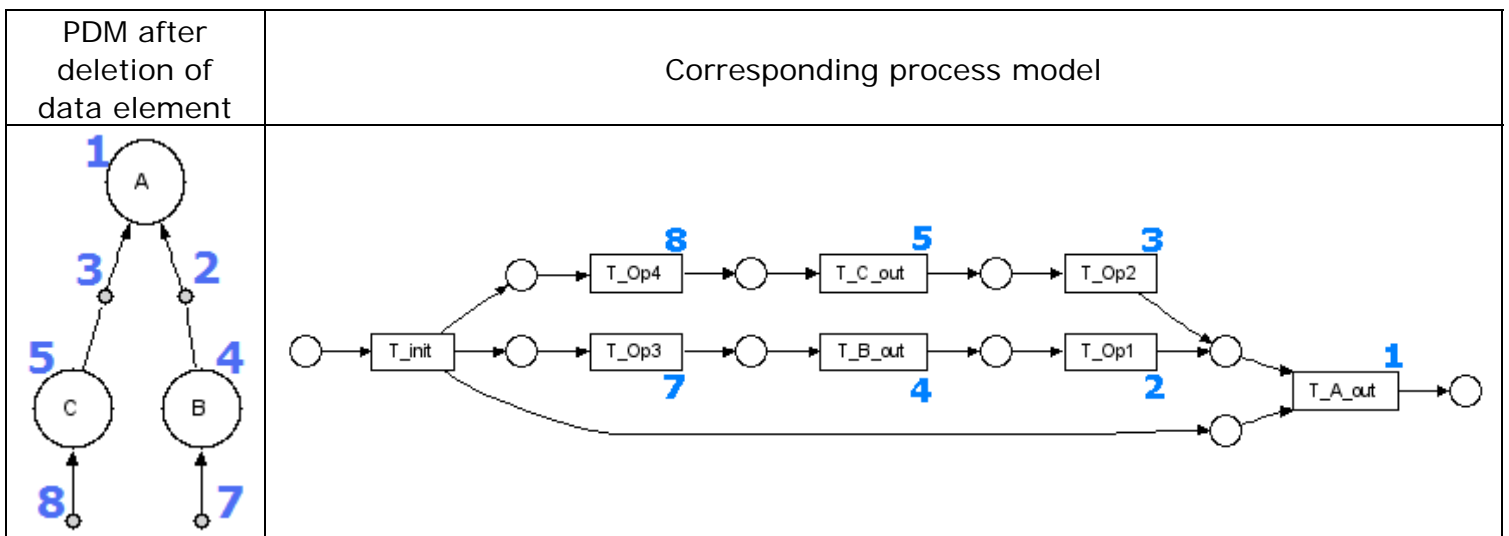

Figure 2.5.6 – PDM and process model after deletion of data element (Echo)

2.5.4. Echo : Addition of a data element

The final change primitive discussed is the addition of a data element. The product data model before addition is shown in Figure 2.5.7. To this product data model a new root element is added. This element needs to be produced through a new operation, which is added as well. The resulting model is depicted in Figure 2.5.8 where the added operation and data element are labeled 10 and 11 respectively.

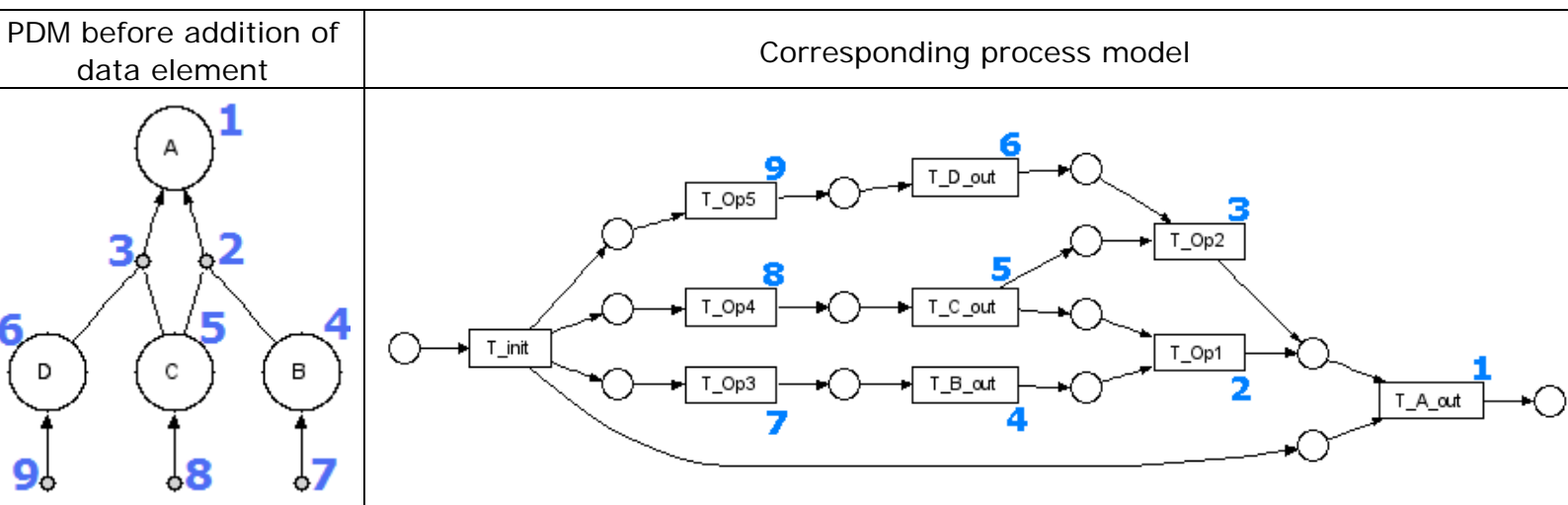

Figure 2.5.7 - PDM and process model before addition of data element (Echo)

Adding a data element to the product data model results in the addition of a transition to the corresponding process model with input place, and a transition representing the operation producing this new data element, if needed.

In this case a new root element *New* is added to the product data model in Figure 2.5.7, using the former root element *A* as input. As both operations and data elements are represented by transitions in the process model, two new transitions (labeled 10 and 11) are added to the end of the process model, with each an input place.

Algorithm Echo also generates a control place, being the output place of the initializing transition, that makes sure the ending transition is only able to fire once, to prevent multiple productions of the end product. Obviously, adding 2 transitions after the end place, changes what the ending transition is, and therefore, this control place is now connected to transition *T_New_out* as depicted in Figure 2.5.8.

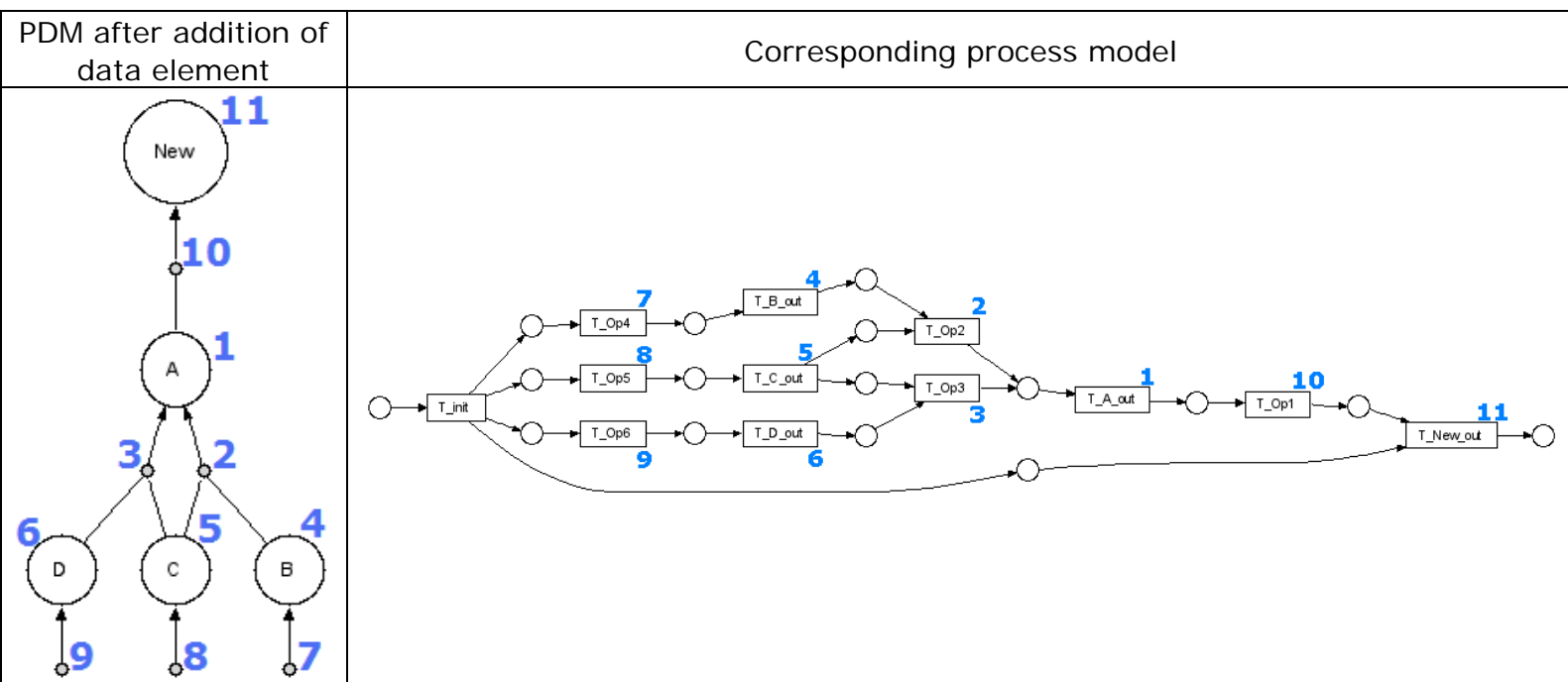

Figure 2.5.8 – PDM and process model after addition of data element (Echo)

2.5.5. Summary of basic change primitives with algorithm Echo

Both data elements and operations are represented by transitions with input place. Operations have as many input places connected as the represented operation has input elements.

With the addition primitives, a transition is added to the process model, with the right amount of input places. Subsequently arcs connect the right transitions to these new input places and an arc connects the new transition to the right place in the model.

If by this change the end transition is altered, the control place is connected to the new end transition.

With the deletion primitives, the transition representing either the operation or data element that is deleted, is simply removed from the process model. Subsequently any dangling sections are deleted.

2.6. Algorithm Foxtrot

Algorithm Foxtrot works in a bottom-up way, starting with the leaf elements of the product data model. All possible steps are computed, creating transitions representing each of these steps (starting from the start place).

The Foxtrot algorithm treats places as representations of all available data elements at that moment. The transitions represent the operations that are possible considering the available data elements at each place. Therefore transitions representing the same operation can and very probably will be present in the process model, as it is often possible to traverse the process model in different ways or produce data elements in different sequences or in parallel, so either first data element *B*, or first element *C*, which can be seen in Figure 2.6.1 where there are two starting branches, one firstly producing *B* (*T_Op3*) and one firstly producing *C* (*T_Op2*).

When all possible steps have been determined, tau transitions are added from all places where the root element is determined, firing into an end place.

The link between the product data model and the process model is less obvious than with the previously discussed algorithms. Each operation in the product data model is represented in the process model by one or more transitions. The places in the process model represent the collection of all determined data elements at that point in the model.

Figure 2.6.1 features a product data model with four operations. The corresponding process model presents 8 transitions representing these operations. The operation, labeled 3, for example, is represented in the process model three times, labeled *3a*, *3b* and *3c*.

2.6.1. Foxtrot : Deletion of an operation

In this section the deletion of an operation is discussed. The operation is deleted from the product data model depicted in Figure 2.6.1. The operation that is deleted is labeled 4 in the model. In Figure 2.6.2 the product data model after deletion of the operation is presented.

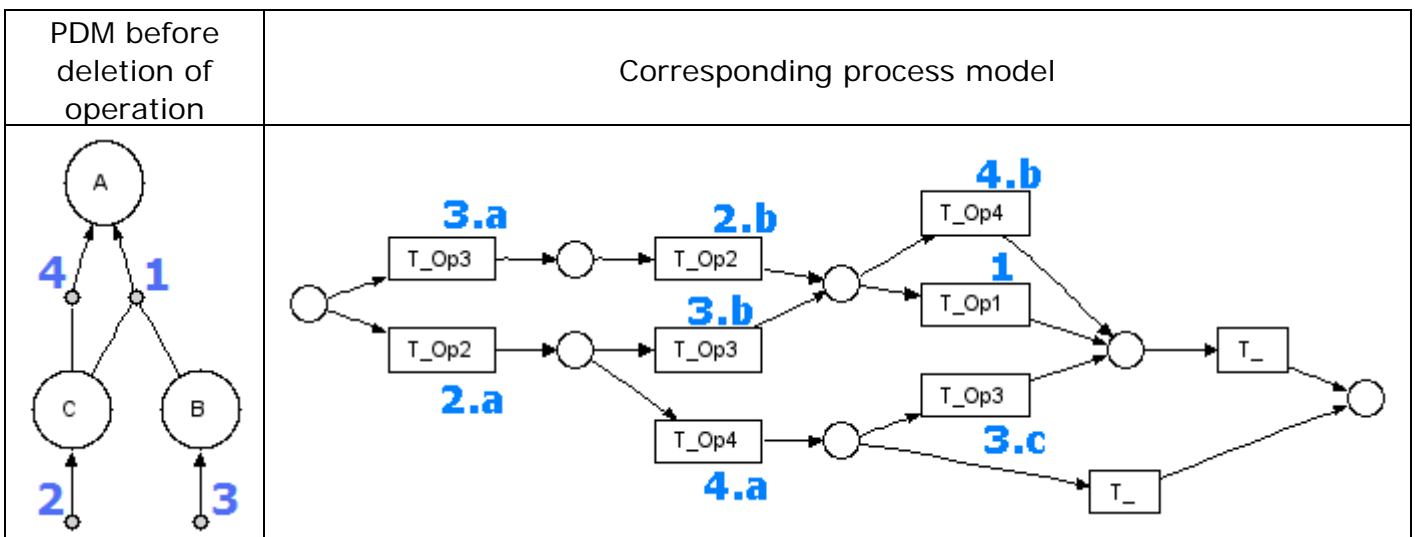

Figure 2.6.1 - PDM and process model before deletion of operation (Foxtrot)

Removing an operation from the product data model affects the resulting process model by removing the corresponding transitions and subsequently any dangling sections from the process model.

The transitions to be removed in this case, are those labeled 4.a and 4.b. 4.b can easily be removed as it is only connected to places that are input and output places to other transitions. The bottom one is a bit trickier, as removing it, also makes its output place unreachable, which makes both the following transitions 3.c and T_ unable to be enabled. Therefore these branches in their entirety are removed as well, resulting in the process model in Figure 2.6.2.

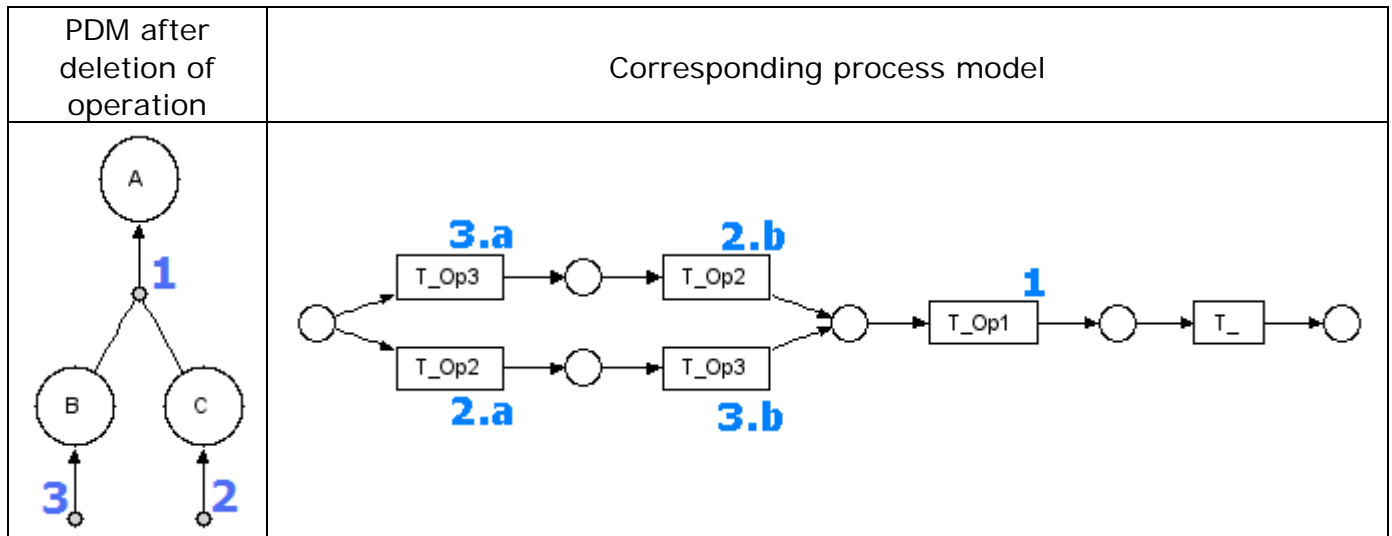

Figure 2.6.2 - PDM and process model after deletion of operation (Foxtrot)

2.6.2. Foxtrot : Addition of an operation

In this section the addition of an operation is discussed. The operation is added to the product data model in Figure 2.6.3. The new operation is a direct production of data element A from only data element C. The product data model after the addition is depicted in Figure 2.6.4.

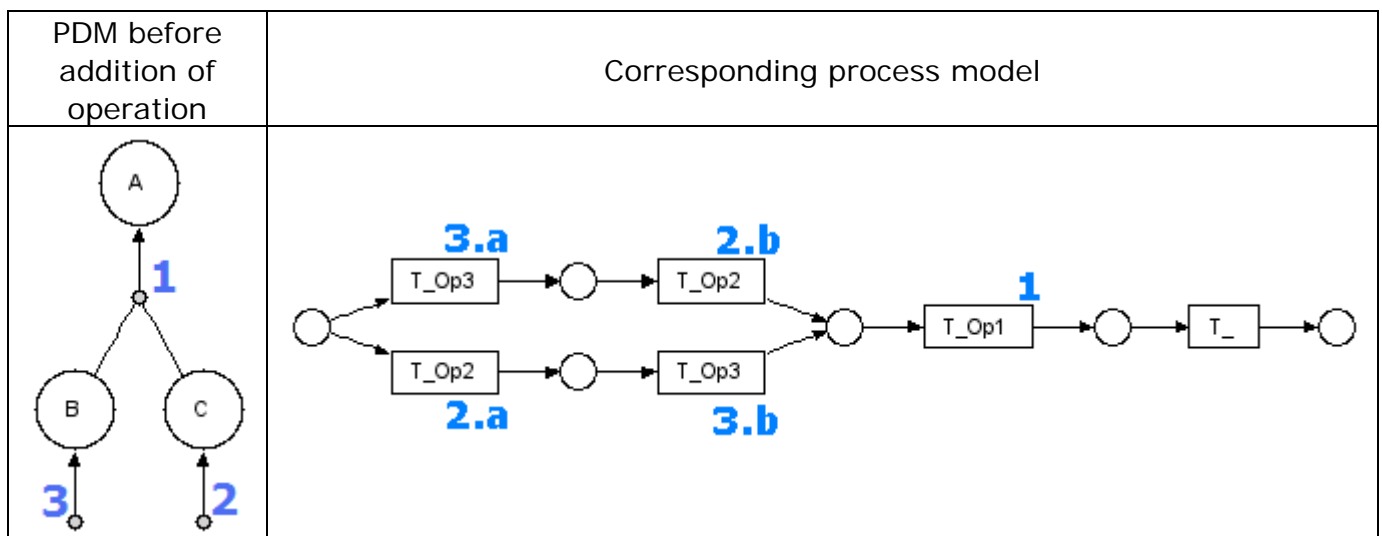

Figure 2.6.3 - PDM and process model before addition of operation (Foxtrot)

Adding an operation to the product data model, can hold big consequences for the corresponding process model as the operation should be able to be performed from several places in the process model, each of which represents a state where the input elements of the operation are determined.

In this case an operation T_Op4 is added (labeled 4), as an enabled operation when data element C is determined. Therefore, from any place, where data element C is determined, an arc will originate towards a new transition T_Op4 , firing into a place where data element A in addition to the data elements that were produced before T_Op4 , is also supposed to have been produced. In this case, every place which is reached through a path where T_Op2 is involved (and before T_Op4 has occurred) gets an outgoing arc towards a new operation T_Op4 .

There are two of these places, one is the joining place of the two branches in the process model in Figure 2.6.3. From this point, either T_Op1 or T_Op4 can be performed to produce data element A . Therefore T_Op4 (labeled 4.b) is placed in parallel to T_Op1 in the process model.

The other place from where T_Op4 can occur, is the place in the bottom branch, between operations T_Op2 and T_Op3 . From here, data element A can be produced through T_Op4 (labeled 4.a). Since in this place root element A is present, the place is connected to the end place through a silent transition. Aside from that, it is still possible to produce data element B through T_Op3 , which results in the construction in Figure 2.6.4.

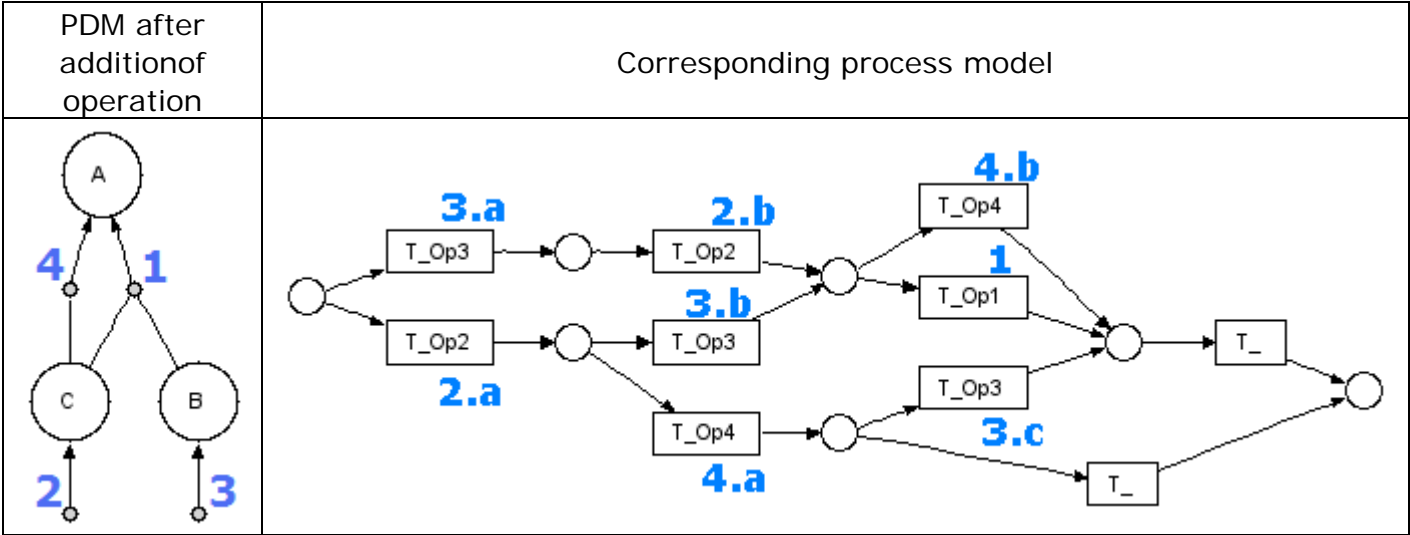

Figure 2.6.4 - PDM and process model after addition of operation (Foxtrot)

2.6.3. Foxtrot : Deletion of a data element

In this section the deletion of a data element is discussed. From the product data model in Figure 2.6.5 data element D is deleted. This means the operation producing data element D is deleted as well. In Figure 2.6.6 the product data model after deletion is depicted.

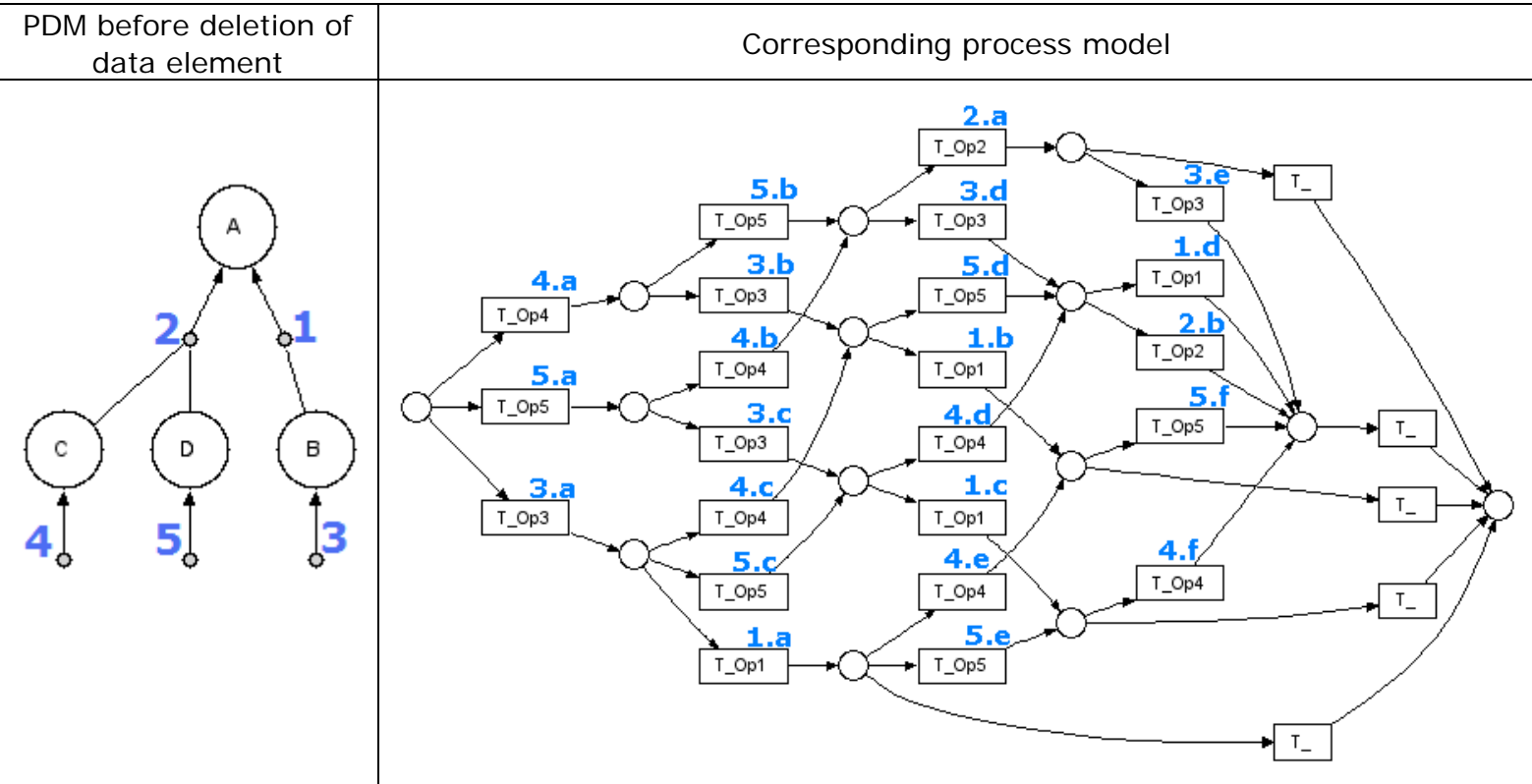

Figure 2.6.5 - PDM and process model before deletion of data element (Foxtrot)

Deleting a data element from the product data model, has a different effect with algorithm Foxtrot, than with the previously discussed algorithms. With algorithm Foxtrot each place represents a collection of determined data elements and therefore a data element can occur in several places. Removing a data element from the product data model will therefore result in the removal of the operations producing the data element and alteration of the operations using the data element.

In this case data element *D* is removed from the product data model in Figure 2.6.5. This also removes the producing operation (T_Op5) from the product data model as well as it alters the operation using data element *D* (T_Op2). Concretely, all transitions T_Op5 (all labeled 5.'x') are removed from the process model. All places where data element *D* is assumed to be determined, should be reevaluated. Places which represent the exact same collection of determined data elements are now merged, as well as the transitions leading to and originating from these places. In effect this means that input and output places to the deleted operation are merged. In this way for example operations 3.*b* and 3.*d* are merged as operation 5.*b* is deleted and its input and output place are merged. Now all transitions and places which can not be reached, are deleted from the process model, resulting in the model depicted in Figure 2.6.6.

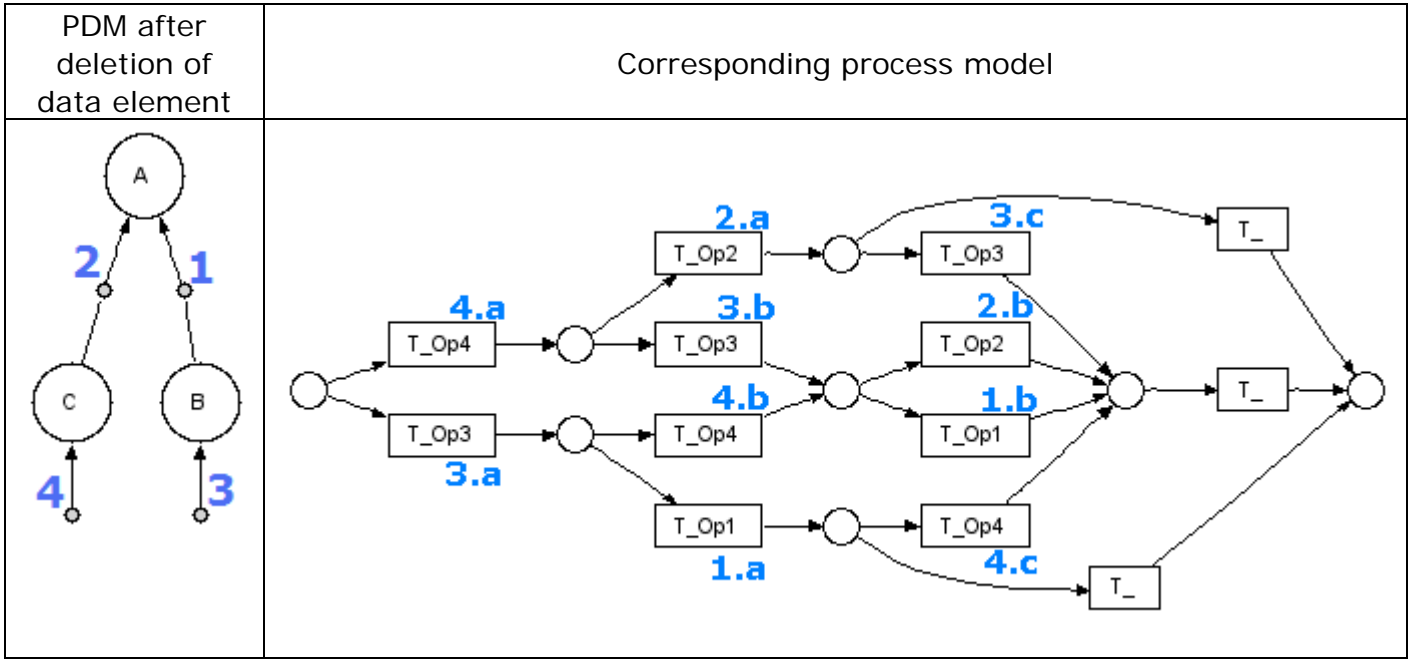

Figure 2.6.6 – PDM and process model after deletion of data element (Foxtrot)

2.6.4. Foxtrot : Addition of a data element

The final change primitive discussed is the addition of a data element. In adding a data element in most cases an operation is added as well, to produce this data element. In this case a new root element (and producing operation) is added to the product data model in Figure 2.6.7. This addition results in the product data model in Figure 2.6.8 where the added operation is labeled 6.

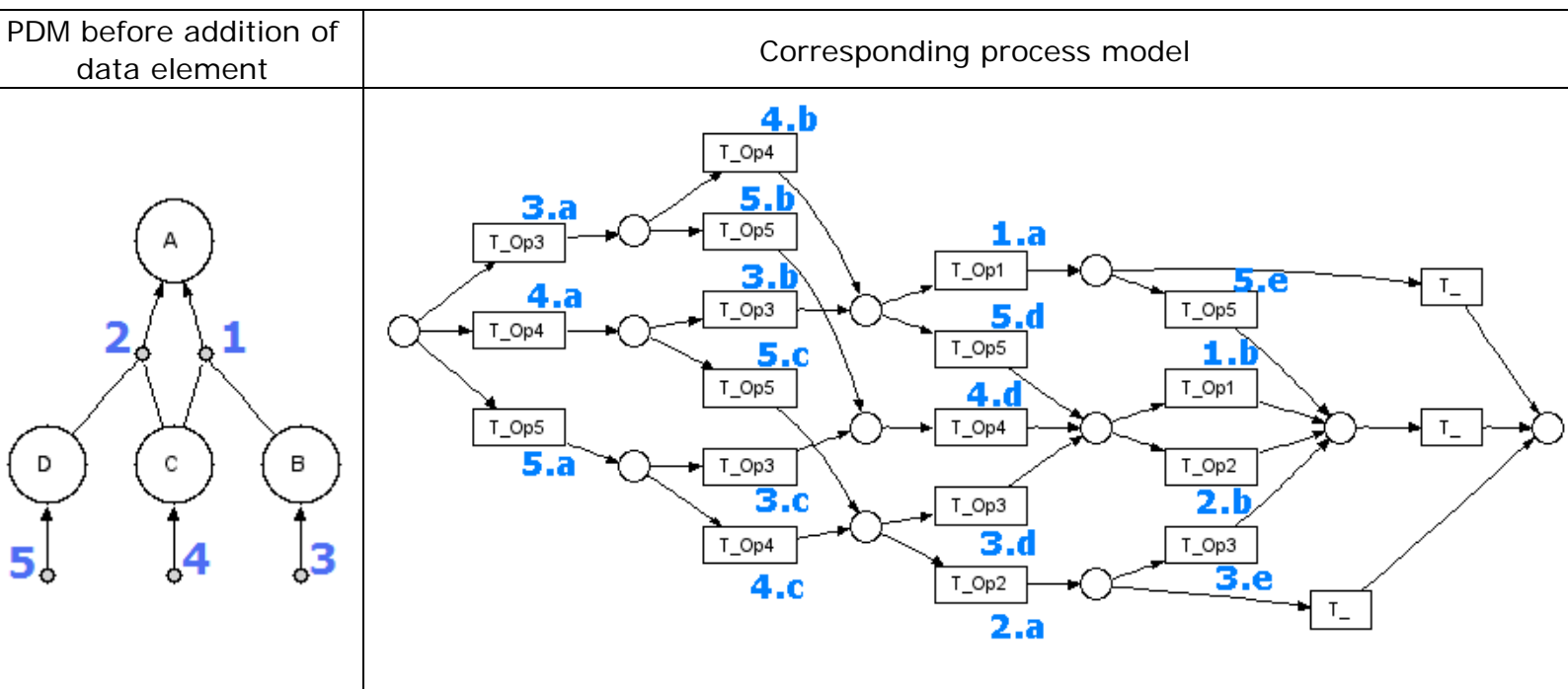

Figure 2.6.7 - PDM and process model before addition of data element (Foxtrot)

Adding a data element to the product data model, means there will be more possible collections of determined data elements. Therefore, more places will be added to the process model, reached through a transition representing the operation producing the newly added data element.

In this specific case, a new data element is added as new root element (*New*) to the product data model in Figure 2.6.7. This element is only able to be determined using data element *A*. Therefore, a transition representing the production of data element *New* (labeled 6.'x') is made reachable from every place, where data element *A* has been determined (and data element *New* has not been determined yet).

The naming of the operations is altered as well, as the numbering starts at the operations closest to the root element, where, in this case, another operation is added. This means that in this case each operation number is incremented with one, as can be seen in Figure 2.6.8.

Also, from every place where data element *New* has been determined, it may be possible to still determine either data element *B* or *D*. The newly added operations to the model, are the following:

Three transitions T_Op1 (one when all other data elements have been determined, and for each branch that has been determined, labeled 6.a, 6.b and 6.c) and the transitions T_Op4 (3.f) and T_Op6 (5.f) following transitions 6.a and 6.b. This makes for a total of 5 new transitions and 3 new places.

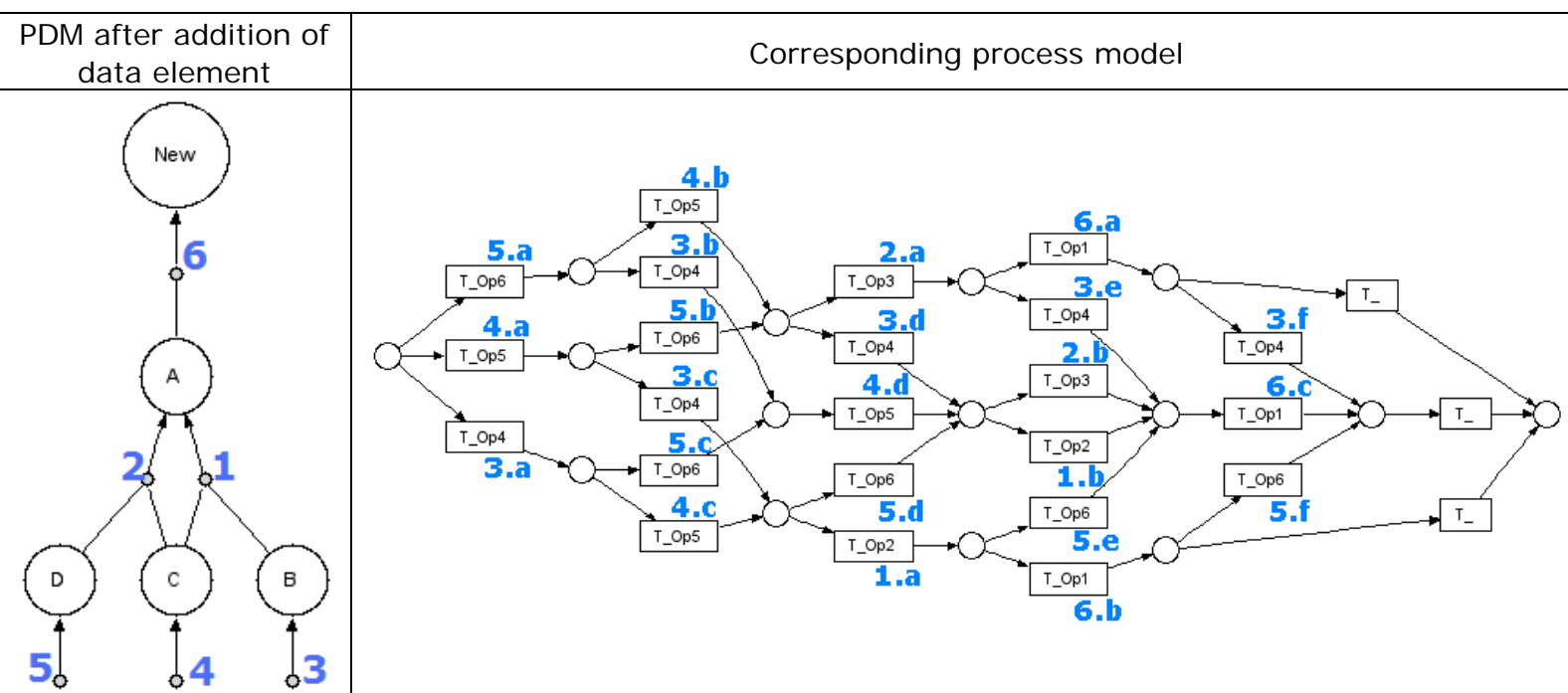

Figure 2.6.8 – PDM and process model after addition of data element (Foxtrot)

2.6.5. Summary of basic change primitives with algorithm Foxtrot

Places in the process model represent collections of data elements that are determined at that place in the process model.

Adding a data element or operation, is not as straightforward as with the other algorithms. An added data element needs to be created by an operation. If it is created by an already existing operation (as a side product) the corresponding process model remains the same (the output place to the transition corresponding to the operation now represents the newly added data element in the collection as well).

With the addition primitives, transitions are added to the process model originating from all the places where the input elements are supposed to be determined (and the output element has not) and the output places represent the collection of elements determined in the input place, combined with the created data element. In the case of the addition of a data element the output place to this new transition is new as well. In this case the remainder of the process model needs to be redetermined.

With the deletion primitives, the transitions representing either the operation or the operation producing the data element that is deleted, are simply removed from the process model. Also all transitions representing operations using a data element, that should no longer be able to be produced, are deleted as well. Eventual dangling sections are removed subsequently also.

2.7. Algorithm Golf

Like the Foxtrot algorithm, the Golf algorithm also treats places as representations of the available data elements at a certain point in the process. This algorithm primarily works in the same way as algorithm Foxtrot, starting bottom-up and generating transitions for all possible steps at each point in the process model. The difference being that in algorithm Golf the execution paths strictly leading to the end product are determined in advance, and the generation of the process model follows these determined paths. This makes the resulting process model in Figure 2.7.1 a more "lean" version of the process model in Figure 2.6.1, at the cost of limiting possibilities further on in the process model.

The link between the product data model and the process model is similar to the link with the Foxtrot algorithm.

Places in the process model represent the entire collection of data elements that are determined at that point in the process model. For each operation that is available at a of the place in the process model, a transition is connected representing this operation. In Figure 2.7.1 an example product data model and corresponding process model is shown. The transitions in the process model are labeled according to the operations in the product data model represented.

2.7.1. Golf : Deletion of an operation

In this section the deletion of an operation is discussed. In Figure 2.7.1 the product data model before deletion is depicted. The operation labeled 4 is deleted from this product data model, resulting in the model shown in Figure 2.7.2.

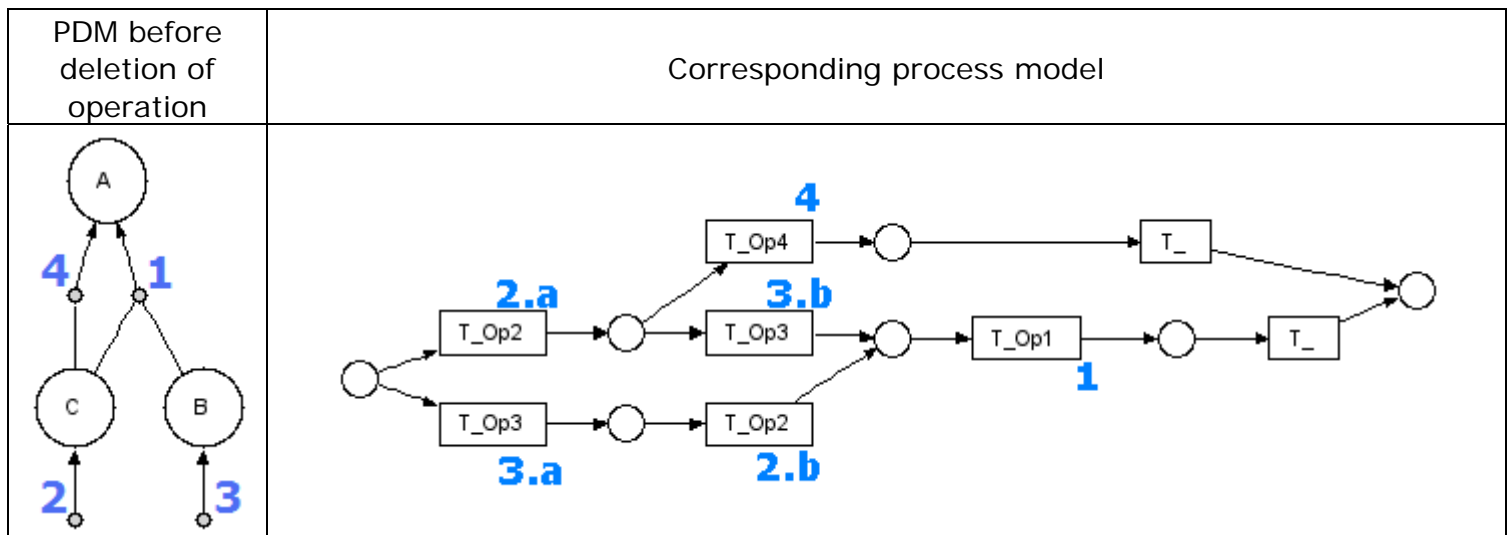

Figure 2.7.1 - PDM and process model before deletion of operation (Golf)

Deleting an operation from the product data model results in the removal of all corresponding transitions, as each operation is represented by one or more transitions in the process model. Of course, any dangling sections are removed.

In this case the operation creating data element *A* by using only data element *C* is deleted. This operation (labeled 4) is translated to transition *T_Op4* in the process model. This transition is removed from the process model, leaving its output place unreachable, and subsequently the following transition *T_*. These are all removed from the process model, as a consequence of removing said operation from the product data model. The resulting process model is depicted in Figure 2.7.2.

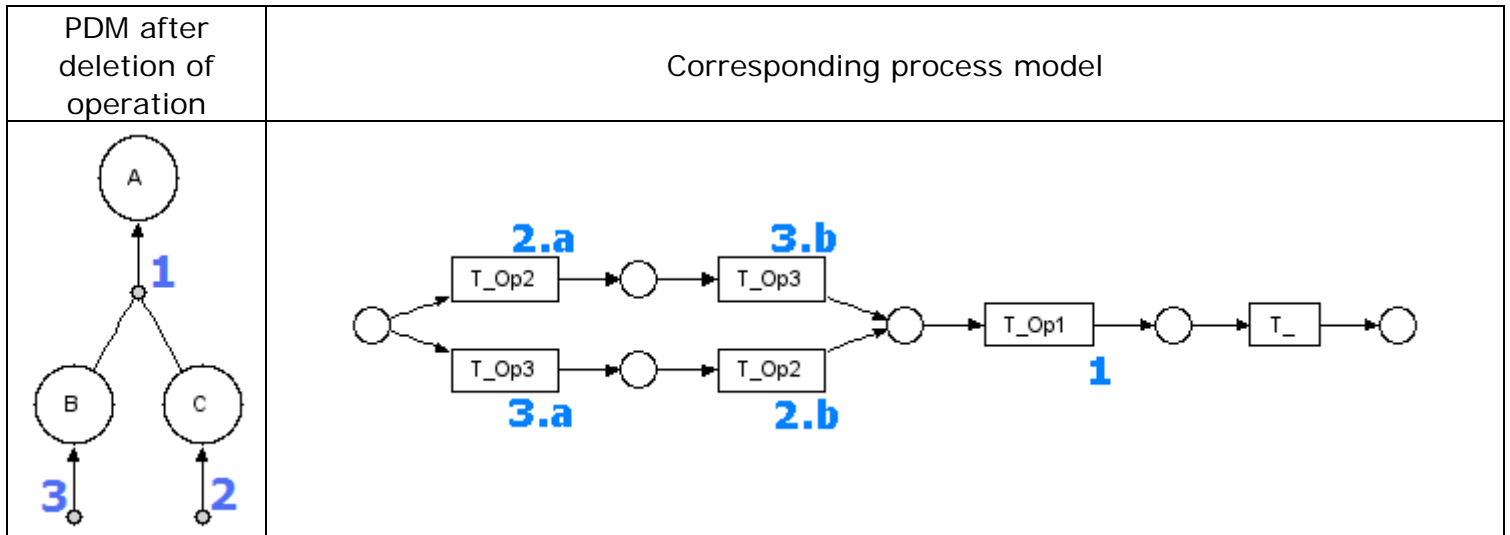

Figure 2.7.2 - PDM and process model after deletion of operation (Golf)

2.7.2. Golf : Addition of an operation

The second change primitive for algorithm Golf that is discussed, is the addition of an operation. An operation is added to the product data model in Figure 2.7.3. This operation produces data element *A* using only data element *C*. In Figure 2.7.4 the operation is added, labeled 4.

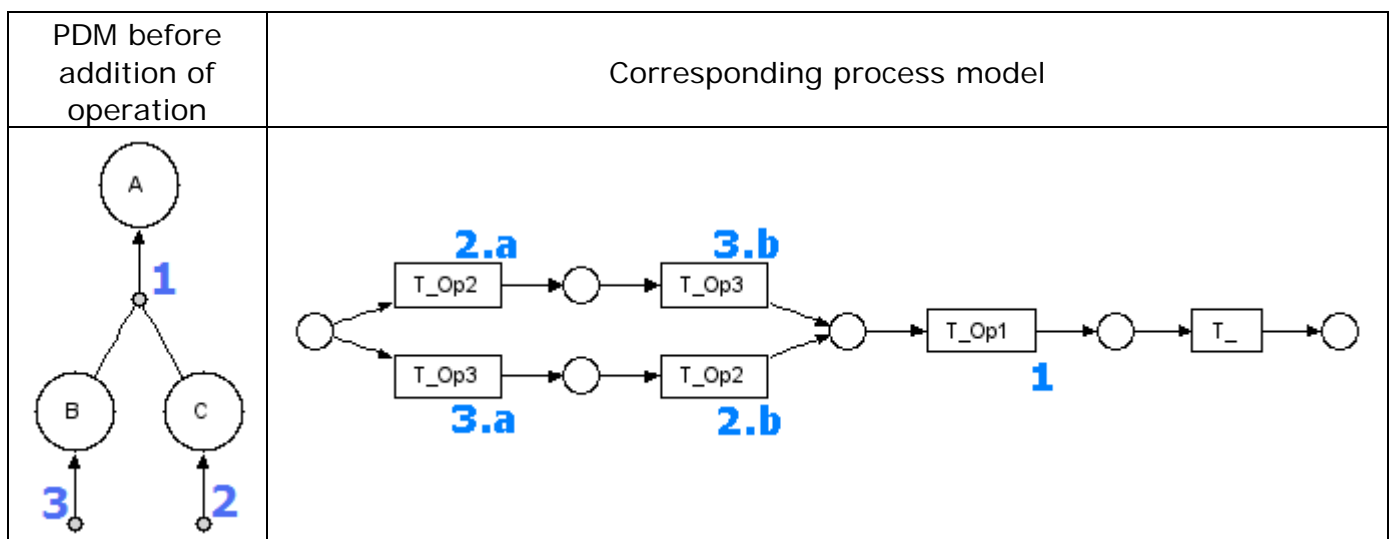

Figure 2.7.3 - PDM and process model before addition of operation (Golf)

Adding an operation to the product data model can influence the corresponding process model in different areas at once, as each operation is represented by a

transition and can occur multiple times within the same model. If the collection of elements combined with the newly added data element is not yet represented in the model, a new output place is created as well, and all possible transitions from here need to be determined.

In this case, an operation is added to the product data model in Figure 2.7.3. This operation can produce data element *A*, by using solely data element *C*.

This algorithm functions similarly to algorithm Foxtrot, with the exception that transitions are not allowed to occur anymore when the root element has been determined. The path to follow in its entirety is determined in advance of starting the process. So it would be illogical to produce data element *B* when it is not going to be used in the process. Therefore the resulting process model will have an added transition *T_Op4*, only following *T_Op2* directly (the transition producing data element *C*) and only in the branch where data element *B* has not been determined yet. Also, after this transition, data element *A* is determined, and no further transitions are needed and therefore not created by algorithm Golf (except for the empty ending transition *T_-*). This results in the process model in Figure 2.7.4.

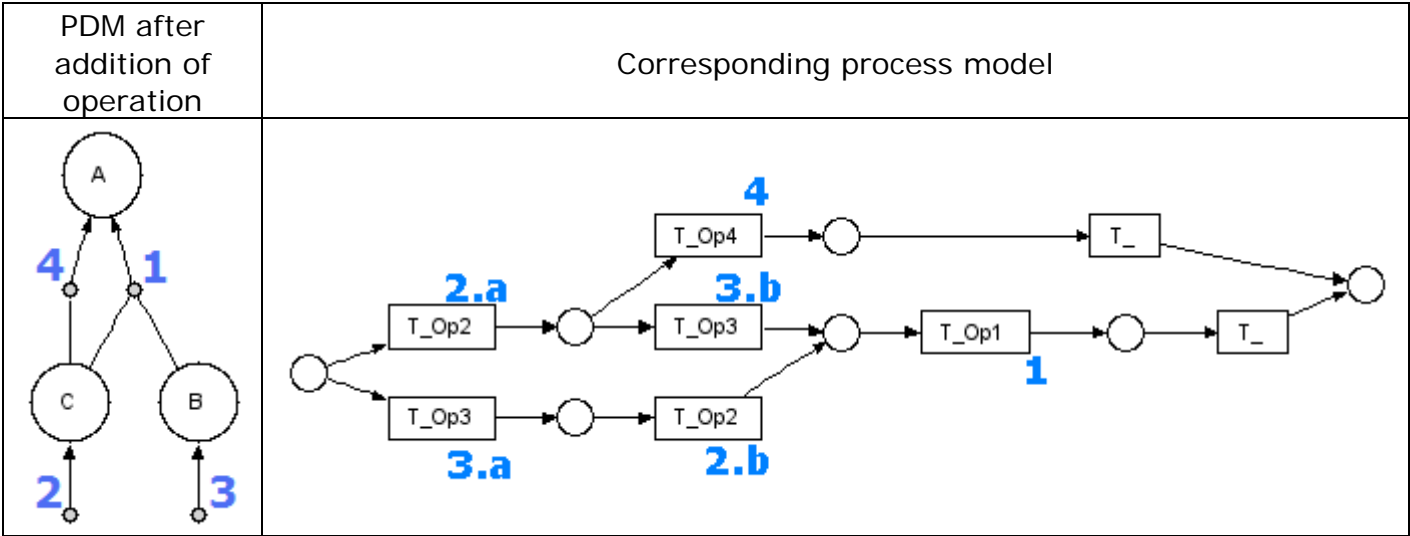

Figure 2.7.4 - PDM and process model after addition of operation (Golf)

2.7.3. Golf : Deletion of a data element

In this section the deletion of a data element is discussed. Figure 2.7.5 shows the product data model from which the data element is deleted. Data element *D* is deleted from the product data model, meaning that the operation labeled 5 should be removed as well.

The resulting product data model is shown in Figure 2.7.6.

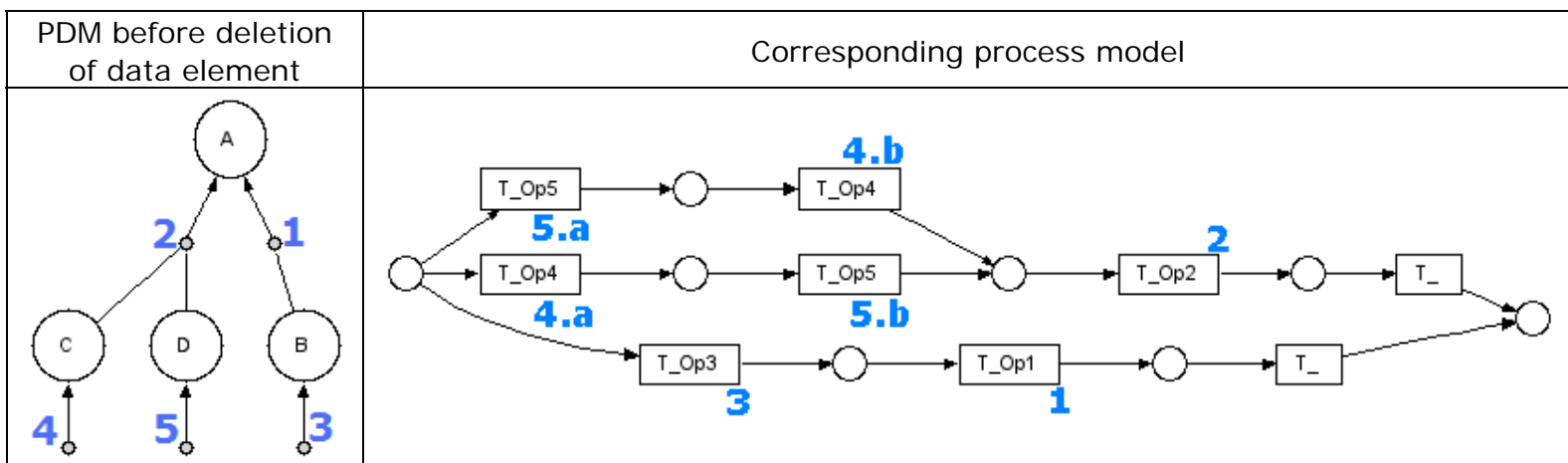

Figure 2.7.5 - PDM and process model before deletion of data element (Golf)

Deleting a data element means that the operation producing that data element is no longer relevant and is deleted. As each place represents the collection of determined data elements at that point, only those places need to be altered, where the data element occurs, which has been deleted. This is in all places where a transition producing the specific element has occurred in the path towards it.

All places following a transition representing the operation that is deleted, are merged with the place preceding the deleted transition, similarly to the procedure with algorithm Foxtrot.

In this specific case the data element *D* is removed from the product data model in Figure 2.7.5. The operation producing data element *D* is represented by transition *T_Op5* and is removed from the process model as well. As transition *T_Op5* is deleted, there is no longer a difference in sequence between that transition and transition *T_Op4* possible, causing the two alternative paths to become one consisting of just transition *T_Op4*. This eliminates one of the two upper branches, and shortens the whole upper branch, resulting in the process model in Figure 2.7.6.

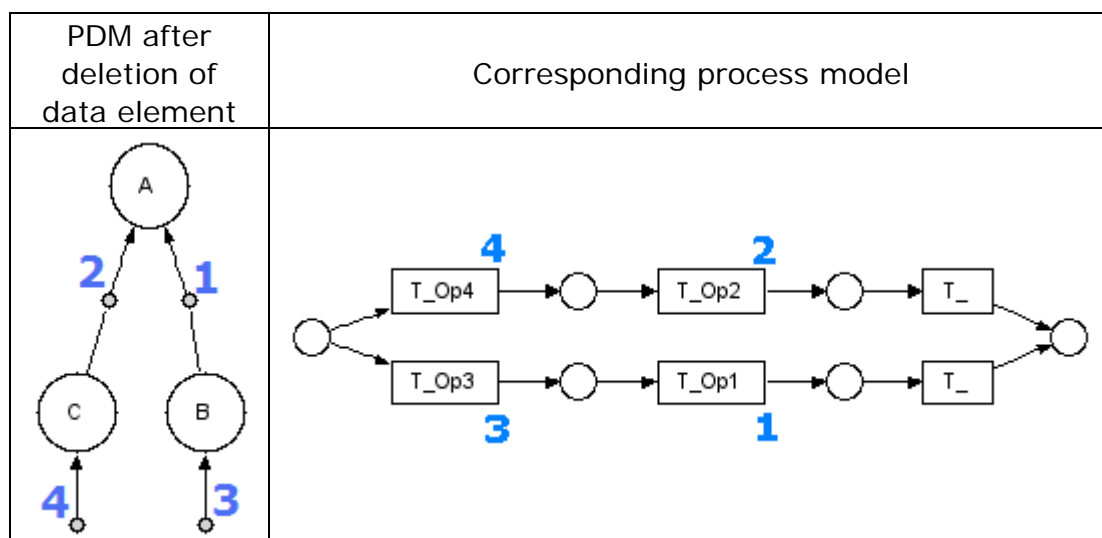

Figure 2.7.6 – PDM and process model after deletion of data element (Golf)

2.7.4. Golf : Addition of a data element

The final change primitive that is discussed, is the addition of a data element. In this case a new root element is added to the product data model in Figure 2.7.7. This new data element needs an operation to produce it as well. The operation and data element are added and shown in Figure 2.7.8 (labeled 6 and named *New* respectively).

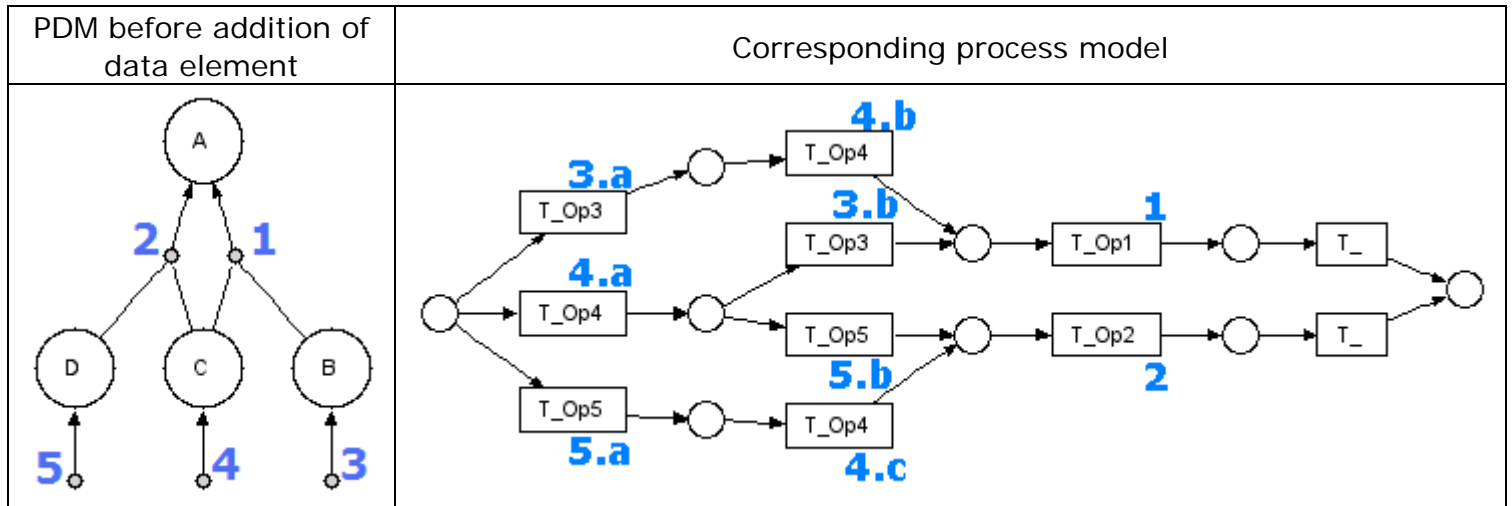

Figure 2.7.7 - PDM and process model before addition of data element (Golf)

Adding a data element means an operation creating that data element should be added as well. A transition representing this operation is added and reachable from all places which represent situations where all data elements that are used by the operation are determined. If there are different places for which this condition holds, then a new operation is added for each alternative.

These transitions have output places where this newly added data element is determined, therefore the output places are new and added to the process model as well. Subsequently the remainder of the model from these new places onwards should be determined as well as the paths from existing parts of the model to these new parts.

In this case a data element *New* is added as new root element, dependant on the old root element *A*. This translates to a new operation possible from all places that are currently "end places" (places from where transition T_- can occur) firing into a new place, to which transition T_- is connected. Also, as described before, the numbering of all the transitions is incremented with one, because the algorithm starts the numbering with transitions closest to the end place, where now a new transition is added.

The resulting process model is depicted in Figure 2.7.8.

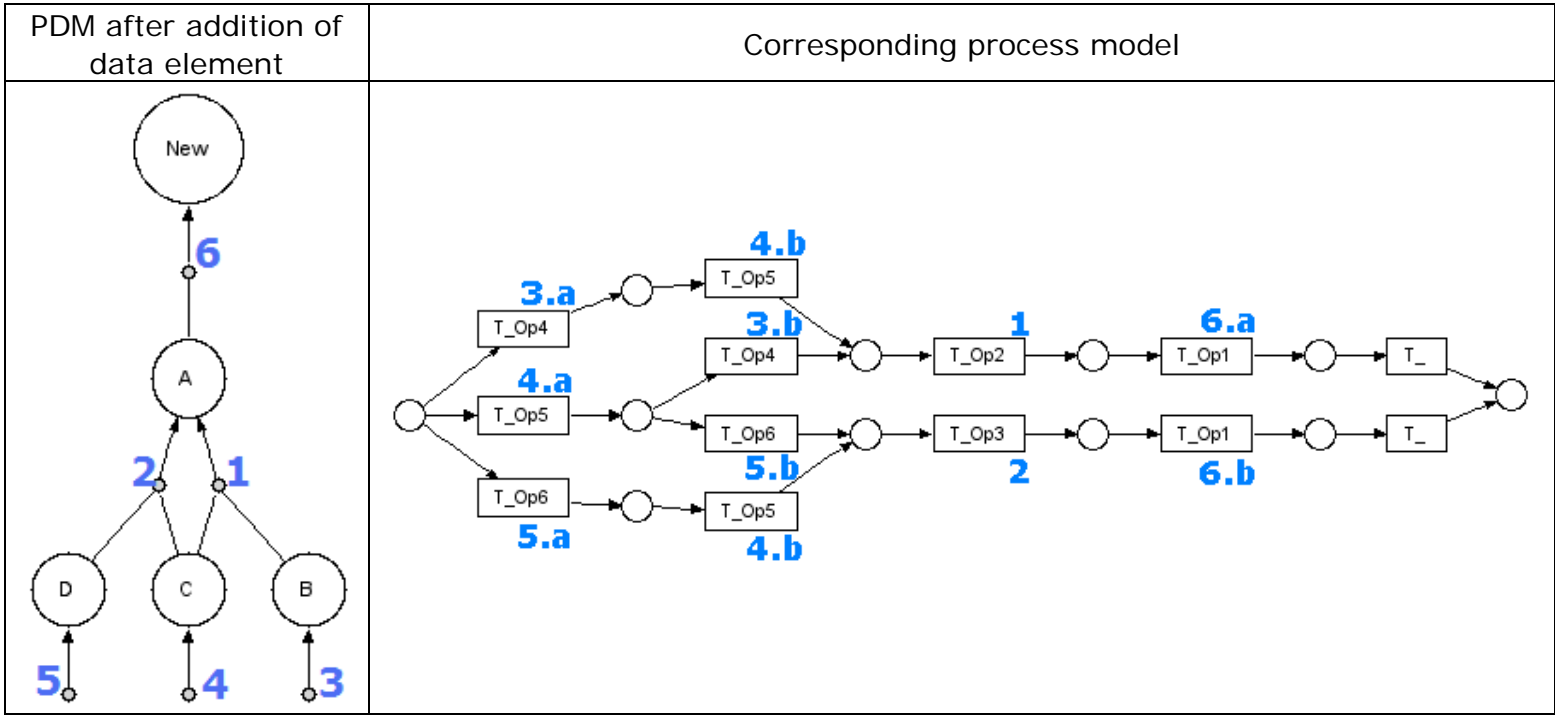

Figure 2.7.8 – PDM and process model after addition of data element (Golf)

2.7.5. Summary of basic change primitives with algorithm Golf

Places in the process model represent collections of data elements that are determined at that place in the process model.

With the addition primitives, transitions are added to the process model originating from all the places where the input elements are supposed to be determined (and the output element has not) and the output places represent the collection of elements determined in the input place, combined with the created data element. In the case of the addition of a data element the output place to this new transition is new as well. In this case the remainder of the process model needs to be (re)determined.

With the deletion primitives, the transitions representing either the operation or the operation producing the data element that is deleted, are simply removed from the process model. Also all transitions representing operations using a data element, that should no longer be able to be produced, are deleted as well. Eventual dangling sections are removed subsequently also.

References

- [1] From Product Data Model to Process Model, algorithms and their classification
J. Kamphuis
Master thesis, Eindhoven, April 2008

- [2] From Product Data Model to Process Model
J. Kamphuis, I. Vanderfeesten, H.A. Reijers, M. van Hattem
Beta Working Paper 238, March 2008

- [3] Product-based Workflow Design.
H.A. Reijers, S. Limam, W.M.P. van der Aalst
Journal of Management Information systems, 20(1): 229-262, 2003

- [4] Product-Based Design and Support of Workflow Processes.
I. Vanderfeesten
PhD thesis, Eindhoven, February 2009