

The measurement of ion-induced cloud nucleation irradiated with a 180-MeV nitrogen ion and proton beams at HIMAC accelerator facility

Asami Suzuki^{1a}, Yoshitaka Itow^a, Takashi Sako^b, Tomoki Nakayama^c, Kimiaki Masuda^a, Fusa Miyake^a, Yutaka Matsumi^a, Kazuhiko Miura^d, Kanya Kusano^a

Institute for Space-Earth Environmental Research, Nagoya University, Furo-cho, Chikusa-ku, Nagoya 464-8601, Japan^a

Institute for Cosmic Ray Research, University of Tokyo, High Energy Cosmic Ray Research Division 5-1-5, Kashiwanoha, Kashiwa, Chiba, 277-8582, Japan^b

Faculty of Environmental Science and Graduate School of Fisheries and Environmental Sciences, Nagasaki University, 1-14, Bunkyo-machi, Nagasaki, Nagasaki 852-8521, Japan^c

Faculty of Science, Tokyo University of Science, Kagurazaka, Shinjuku-ku, Tokyo 162-8601, Japan^d

Ion-induced nucleation by cosmic rays influenced by solar modulation is of interest, and several studies with radioactive sources or accelerator beams have been performed. We focused on ionization with high-linear energy transfer (LET) particles, such as protons, neutrons, and ions, in secondary cosmic rays and the ion density of the secondary cosmic rays near the ground using the excel-based program for calculating atmospheric cosmic-ray spectrum (EXPACS). According to the calculation, not only muons but also protons and neutrons leave substantial traces of solar modulation at an altitude of 3 km from the ground. To verify the ion-induced nucleation by these secondary high-LET cosmic rays, a chamber experiment was conducted at the accelerator facility HIMAC. Using a chamber with a capacity of 75 L, experiments were conducted by irradiating protons and nitrogen ion beams with a constant energy of 180 MeV/u with varying intensity.

The experimental results confirm that the ion density and aerosol density increased as the beam intensity increased. The aerosol density was found to be proportional to the ion density, but irrelevant to the ionization density. It was concluded that the ion-induced nucleation by high-LET secondary cosmic rays, such as protons and neutrons, provides no evidence of enhancement owing to ionization density and cannot account for the claimed variation of cloud formation due to the solar modulation.

*36th International Cosmic Ray Conference -ICRC2019-
July 24th - August 1st, 2019
Madison, WI, U.S.A.*

¹Speaker

© Copyright owned by the author(s) under the terms of the Creative Commons Attribution-NonCommercial-NoDerivatives 4.0 International License (CC BY-NC-ND 4.0).

<http://pos.sissa.it/>

1. Introduction

N. Marsh and H. Svensmark reported a correlation between low cloud (<3.2 km) coverage and the counting rate of ground neutron monitors [1], which recorded an 11-year solar modulation cycle of galactic cosmic ray (GCR) intensity. Their result suggests that the ionization of air by GCRs is responsible for carrying the effect of solar modulation in low cloud nucleation, as GCRs can penetrate deep into the atmosphere [2]. However, quantitative discussions require more information on the fundamental processes. Several chamber experiments have been conducted to study the mechanism of cloud nucleation by GCRs, or high-energy particles in general. Among them, the SKY experiment by the Svensmark group and the CLOUD experiment at CERN made pioneering and exhaustive studies in this field, respectively [3, 4].

In these studies, high-energy charged pion beams and gamma rays from radioactive sources were adopted to simulate cosmic rays (CRs) in the atmosphere (secondary CRs, hereafter). Charged particles with relativistic energy, including electrons produced by gamma rays, are mostly minimum ionizing. Meanwhile, the correlation with cloud coverage was identified in the neutron monitor data that recorded the flux of high-linear energy transfer (LET) secondary CRs but not muons. Because muons require higher primary CR energy in production, the amplitude of their solar modulation is smaller than that of the high-LET component. High-LET secondary CRs, predominantly protons and neutrons, generally have subrelativistic energy near the ground and produce ions with higher ion density, because of their low velocity or higher charge in case of nuclei scattered by neutrons. Ionization rates by secondary CRs were calculated using the Excel-based Program for calculating Atmospheric Cosmic-ray Spectrum (EXPACS)[5,6,7] and amplitudes of their solar modulation for different types (hadrons and muons) of secondary CRs are examined. Amplitude of hadronic ionization at the altitude 3 km was found to be about 1.2 times that of muons ('amplitude' is defined as maximum minus minimum over the period, hereafter). If high-density ion production by high-LET secondary CR particles results in the nonlinear enhancement or suppression of nucleation, it would be a substantially new or possibly dominant contribution to the correlation. However, such an effect was not accessible by the previous experiments. Henceforth, high-LET secondary CR particles are simply called "hadronic components" or "hadrons."

In this work, the effects of high-LET particles on ion-induced nucleation were studied by chamber experiments using nuclear beams with different charges (proton and nitrogen ion) on ion-induced nucleation at the Heavy Ion Medical Accelerator in Chiba (HIMAC).

2. Experimental Measurements

2.1 Beam

In this study, fully ionized nitrogen ion and proton beams were irradiated at the HIMAC in the National Institute of Radiological Sciences (NIRS). As shown in Fig.1, a beam was irradiated along the central axis of the reaction chamber toward a stainless-steel window attached to the side of the chamber with a thickness of ~ 200 μm . The beam diameter was approximately 1 cm, with an energy of 180 MeV/u and an intensity range of $0 \sim 10^5$ /spill. As the electric charges z between a proton and a nitrogen ion are different by a factor of 7, the ionization densities are 49-times

different. However, the actual ionization density was limited by the recombination of ion pairs and much less. A spill, or beam extraction from the accelerator ring to the experimental hall, has a 3.3-s cycle, within which 1 s was occupied by beam particles. The number of radiation particles was counted at intervals of 1 s with plastic scintillators, as shown in Fig. 2.

The nitrogen ion was irradiated in RUN1 and RUN2, while the proton was irradiated in RUN3. In each RUN, the ultraviolet (UV) lamp in the chamber was turned on 30 min after the beam irradiation. After this, the beam intensity was changed in several steps, including measurements of the background without a beam.

2.2 Reaction chamber and Gas System

In this study, the effect of ion-induced nucleation for the two-component homogeneous nucleation with water and sulfuric acid was studied. The reaction chamber used in this experiment is shown in Fig. 1. The cylindrical reaction chamber to be exposed to the accelerator beam has an inner radius of 20 cm, a length of 60 cm, and a volume of 75 L, made of electro-polished stainless steel. After removing the particles $>0.3 \mu\text{m}$ and water vapor, the NO_x - SO_2 - O_3 - CO - HCl free gas was produced from the air by the zero-gas generator with charcoal and paraffin filters, and was continuously flowed into the chamber at a flow rate of 5 L/min.

Water vapor, ozone, and sulfuric acid were added to the pure air before introduction to the chamber. The relative humidity (RH) was controlled by changing the mixture ratio of the humidifier using distilled water. The temperature and RH in the chamber were controlled between 25.8 and 26.3 degree, and between 37.8% and 40.3%, respectively. The pressure in the chamber was 1000 mbar. The ozone was generated by irradiating UV radiation with a wavelength of 185 nm from a pen-type low-pressure mercury lamp. Oxygen gas was supplied with a flow rate of 5 standard cc per minute (scm), and the ozone concentration was controlled at 63 ± 0.6 ppbv during the experiments by changing the position of the lamp. Sulfur dioxide was also supplied constantly. The concentrations of these precursor gases were similar with those typically observed in the lower troposphere [8].

After the concentrations of each precursor gas became stable, the chamber was irradiated with another UV light of 254 nm wavelength from another pen-type low-pressure mercury lamp. The radiant intensity was $5 \mu\text{W}/\text{cm}^2$ (at 1 m distance) - $50 \mu\text{W}/\text{cm}^2$ (at 0.3 m distance; that is, from the lamp to the inner wall of the chamber). By the UV light irradiation, OH radicals were generated through the reaction of O(1D), which came from photodissociation of the ozone, with water vapor. The OH radicals initiated the oxidation of SO_2 and caused the formation of sulfuric acid. The concentration of sulfuric acid produced in the chamber was estimated from the loss of SO_2 in the chamber to be 1.2 ppbv.

The ion density was measured with a 1-s interval by a Gerdien-condenser type ion counter, with a size of 105 mm \times 100 mm \times 250 mm and a resolution of 1 /cc, during which the air flow was 3 L / min. Only negative ions were measured in this study.

The particle size distribution of aerosol was measured using a scanning mobility particle sizer (SMPS) comprising a differential mobility analyzer (DMA) and a condensation particle counter (CPC). In this study, integrated particle number concentrations in the range of 2.09–66.1 nm were measured at intervals of 180 s (scan up time of 150 s and retrace time of 30 s) in the analyses.

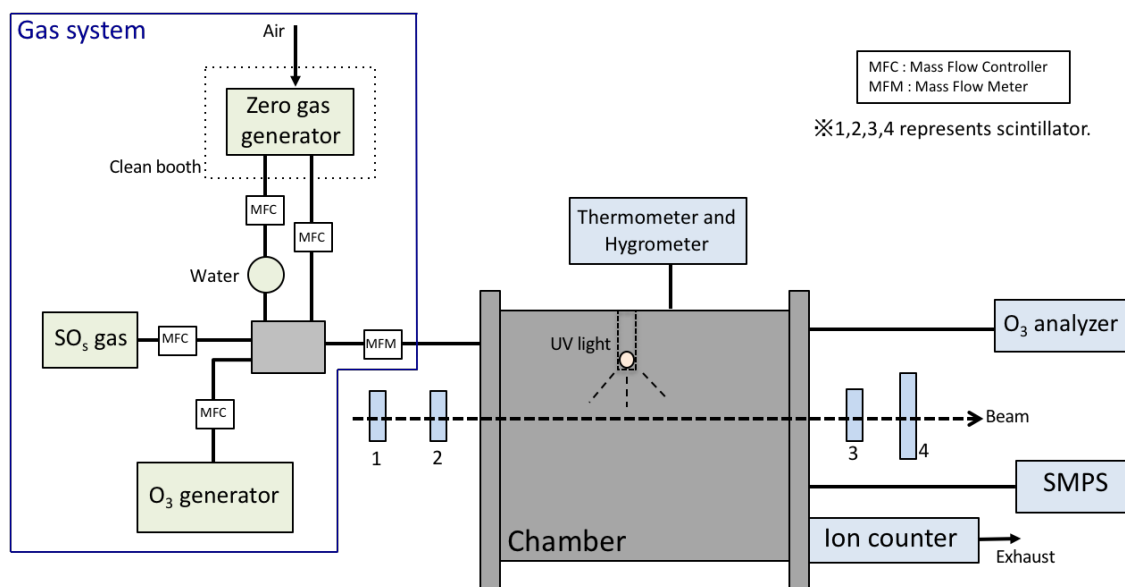

Fig 1: Diagram of the chamber system.

3. Results

We conducted an 11-h irradiation experiment three times at intervals of 38 h between the consecutive RUNs. The nitrogen ion beam was irradiated two times (RUN1 and RUN2), while the proton beam was irradiated once (RUN3). An example of the experimental results (during RUN2) is shown in Fig. 2. Upon UV irradiation, spike-shaped rises in the ion density and the aerosol density were observed. After stabilizing, we began to change the beam intensity. Variations in the ion density and the aerosol density were observed when the beam intensity was changed. The temperature increased by 0.94 ± 0.25 degree (average $\pm 1\sigma$), the RH decreased by $2.72 \pm 0.65\%$ and the ozone concentration decreased by 4.38 ± 0.82 ppbv within 3 h of UV irradiation. It should be noted that the magnitudes of these parameters were almost the same before and after the beam intensity change. The other two RUNs showed similar behaviors.

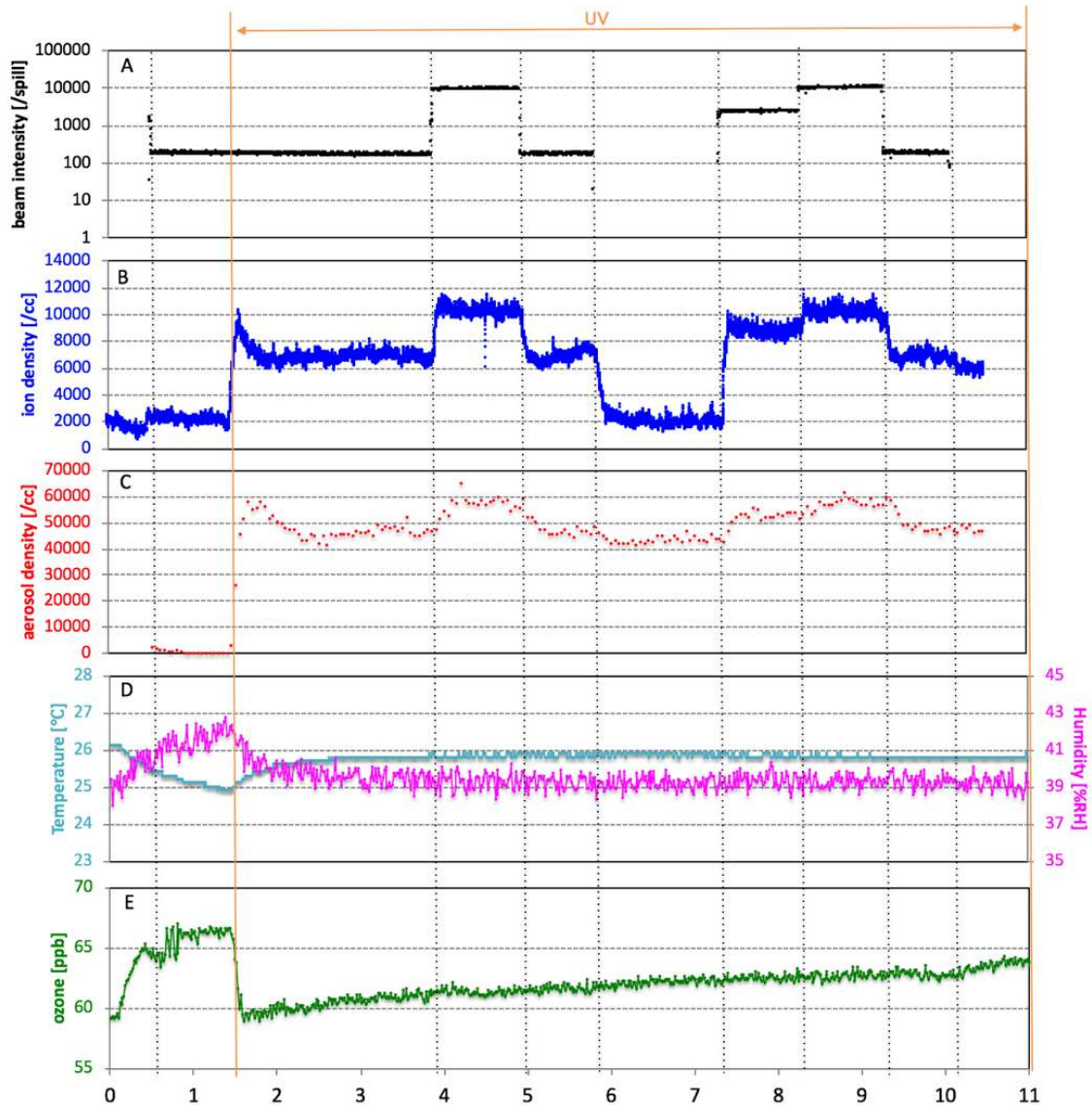

Fig. 2: Temporal variation of (A) beam intensity, (B) ion density, (C) aerosol density, (D) temperature and RH, and (E) ozone concentration in the chamber during RUN2. The x-axis indicates the elapsed time, where 0 s is defined as the time the measurement started. The vertical black dotted lines indicate the time when the beam intensity was changed. The vertical orange lines indicate the time interval of UV irradiation.

Changes in the aerosol density, Δ_{aerosol} (“ Δ_{aerosol} ” is obtained by subtracting the background value from the aerosol density at the time of beam irradiation), with changes in the ion density, Δ_{ion} (“ Δ_{ion} ” is obtained by subtracting background value from ion density during began irradiation), are shown in Fig. 3. One could see that as the Δ_{ion} increases, the Δ_{aerosol} also increases. Overall behavior was same for all the three RUNs. While a substantially higher ionization rate in the nitrogen beam than in the proton beam is expected, the aerosol density was found to be proportional to the ion density, but irrelevant to the LET.

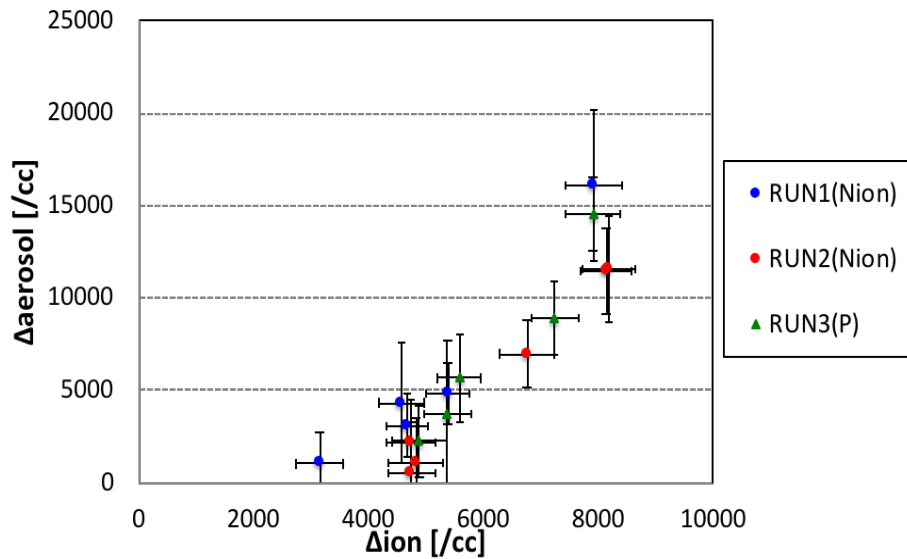

Fig. 3: Relationship between the Δ aerosol and the Δ ion for N ion beam (blue and red circles, respectively) and proton beam (green triangles).

4. Conclusions

We discussed the potential impact of the ionization with high-LET particles to ion-induced cloud nucleation and possible explanation to claimed solar modulation in cloud formation in the lower atmosphere. According to the EXPACS calculation, not only muons but also protons and neutrons leave substantial traces of solar modulation at an altitude of 3 km from the ground. To verify the ion-induced nucleation by these secondary high-LET cosmic rays, such as protons, neutrons, and ions, a chamber experiment was conducted by irradiating protons and nitrogen ion beams at the accelerator facility HIMAC with a constant energy of 180 MeV/n and varying intensity.

The experimental results confirm that the ion density and aerosol density increased as the beam intensity increased. The aerosol density was found to be proportional to the ion density, but irrelevant to LET. It was concluded that ion-induced nucleation by high-LET secondary cosmic rays, such as protons and neutrons, provides no evidence of enhancement owing to the ionization density and does not account for the claimed variation of cloud formation due to solar modulation.

References

- [1] Marsh, N. & Svensmark, H. (2000) Phys. Rev. Let. **85**, 5004–5007.
- [2] Manninen, H.E., et al. (2010) EUCAARI ion spectrometer measurements at 12 European sites – analysis of new particle formation events. Atmos. Chem. Phys. **10**, 7907-7927.
- [3] Duplissy, J., et al. (2010) Results from the CERN pilot CLOUD experiment. Atmos. Chem. Phys. **10**, 1635–1347.
- [4] Svensmark, H., et al. (2007) Experimental evidence for the role of ions in particle nucleation under atmospheric conditions. Proc. R. Soc. A **463** 385–396.

- [5] <https://phits.jaea.go.jp/expacs/>
- [6] Sato, T. (2016) Analytical Model for Estimating the Zenith Angle Dependence of Terrestrial Cosmic Ray Fluxes. PLOS ONE **11**(8): e0160390.
- [7] Sato, T. (2015) Analytical model for estimating terrestrial cosmic ray fluxes nearly anytime and anywhere in the world: Extension of PARMA/EXPACS. PLOS ONE **10**(12): e0144679.
- [8] Seinfeld, J.H. & Pandis, S.N. (1998) Atmospheric chemistry and physics, New York, NY: Wiley.